



US0D1019245S

(12) **United States Design Patent**
Cai

(10) **Patent No.:** **US D1,019,245 S**

(45) **Date of Patent:** **** Mar. 26, 2024**

(54) **MILK WARMER**

Primary Examiner — Ricky Pham

(71) Applicant: **Shenzhen DeOne Innovation Technology Co., LTD.**, Guangdong (CN)

(57) **CLAIM**

The ornamental design for a milk warmer, as shown and described.

(72) Inventor: **Jiongjun Cai**, Guangdong (CN)

(**) Term: **15 Years**

(21) Appl. No.: **35/517,464**

(22) Filed: **May 26, 2023**

(80) **Hague Agreement Data**

Int. Filing Date: **May 26, 2023**

Int. Reg. No.: **DM/229232**

Int. Reg. Date: **May 26, 2023**

Int. Reg. Pub. Date: **Jun. 9, 2023**

(30) **Foreign Application Priority Data**

Apr. 19, 2023 (CN) 202330217474.1

(51) **LOC (14) Cl.** **07-02**

(52) **U.S. Cl.**

USPC **D7/326; D7/323**

(58) **Field of Classification Search**

USPC D7/323, 326–327, 368, 376–378, 386, D7/533, 536, 601, 602, 605, 665
(Continued)

(56) **References Cited**

U.S. PATENT DOCUMENTS

D260,350 S * 8/1981 Kahlcke D7/378
6,089,143 A * 7/2000 Figueroa A47J 36/165
99/332

(Continued)

OTHER PUBLICATIONS

W-maxa Fast Baby Bottle Warmer. Date earliest reviewed on Amazon.com Oct. 30, 2023. <https://www.amazon.com/dp/B0C68FTN34/ref> (Year: 2023).*

DESCRIPTION

- 1. Milk warmer
- 1.1 : Perspective
- 1.2 : Front
- 1.3 : Back
- 1.4 : Left
- 1.5 : Right
- 1.6 : Top
- 1.7 : Bottom
- 1.8 : Perspective
- 1.9 : Front
- 1.10 : Back
- 1.11 : Left
- 1.12 : Right
- 1.13 : Top
- 1.14 : Bottom
- 1.15 : Perspective
- 1.16 : Front
- 1.17 : Back
- 1.18 : Left
- 1.19 : Right
- 1.20 : Top
- 1.21 : Bottom
- 1.22 : Perspective
- 1.23 : Front
- 1.24 : Back
- 1.25 : Left
- 1.26 : Right
- 1.27 : Top
- 1.28 : Bottom

FIG.1.1 is a perspective view of a milk warmer component supply according to a first embodiment shown as component 1 removed from the assembly in Figs.1.22-1.28 for clarity of disclosure; FIG.1.2 is a front view thereof; FIG.1.3 is a rear view thereof; FIG.1.4 is a left side view thereof; FIG.1.5 is a right side view thereof; FIG.1.6 is a top view thereof;

(Continued)

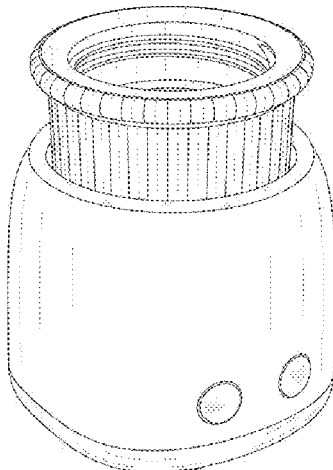

FIG.1.7 is a bottom view thereof; FIG.1.8 is a perspective view of a feeding bottle adapting supply shown as component 2 removed from the assembly in Figs.1.22-1.28 for clarity of disclosure; FIG.1.9 is a front view thereof; FIG.1.10 is a rear view thereof; FIG.1.11 is a left side view thereof; FIG.1.12 is a right side view thereof; FIG.1.13 is a top view thereof; FIG.1.14 is a bottom view thereof; FIG.1.15 is a perspective view of a milk warmer main body supply shown as component 3 removed from the assembly in Figs.1.22-1.28 for clarity of disclosure; FIG.1.16 is a front view thereof; FIG.1.17 is a rear view thereof; FIG.1.18 is a left side view thereof; FIG.1.19 is a right side view thereof; FIG.1.20 is a top view thereof; FIG.1.21 is a bottom view thereof; FIG.1.22 is a perspective view of combined a milk warmer where component 1, component 2 and component 3 are shown in an assembled state; FIG.1.23 is a front view thereof; FIG.1.24 is a rear view thereof; FIG.1.25 is a left side view thereof; FIG.1.26 is a right side view thereof; FIG.1.27 is a top view thereof; FIG.1.28 is a bottom view thereof. The broken line portions of the drawings are for illustrative purposes only and form no part of the claimed design.

1 Claim, 28 Drawing Sheets

(58) **Field of Classification Search**
 CPC A01J 9/08; A23L 3/10; A47J 27/04; A47J 27/004; A47J 27/06; A47J 36/24; A47J 36/165; A47J 36/2411; A47J 36/2416; A47J 36/2433; A47J 36/2438; A47J 39/00; A47J 39/006; A47J 41/00; A47J 43/25; B02C 1/08; H05B 3/0004; F21V 33/00
 See application file for complete search history.

(56) **References Cited**
 U.S. PATENT DOCUMENTS
 D448,236 S * 9/2001 Murray D7/386
 6,444,956 B1 * 9/2002 Witcher F21V 33/00
 219/386
 D510,238 S * 10/2005 Yen D7/378
 8,045,848 B2 * 10/2011 Wortley A47J 36/2438
 392/444
 D716,096 S * 10/2014 Krooshof D7/326
 D782,866 S * 4/2017 Suess D7/378
 D794,385 S * 8/2017 Lee D7/378
 D815,486 S * 4/2018 Suess D7/378
 D817,080 S * 5/2018 Seidl A47J 43/25
 D7/377
 D904,822 S * 12/2020 Koszylko D7/378
 D982,371 S * 4/2023 Liang D7/323

* cited by examiner

1.1

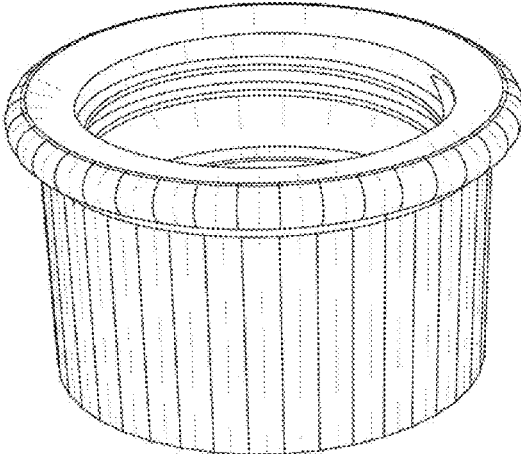

1.2

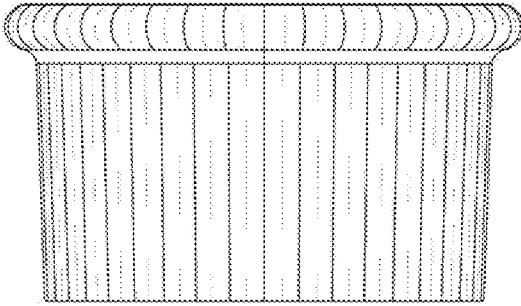

1.3

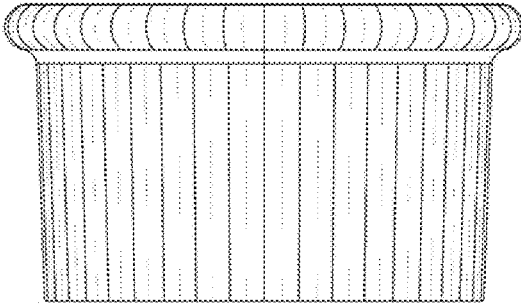

1.4

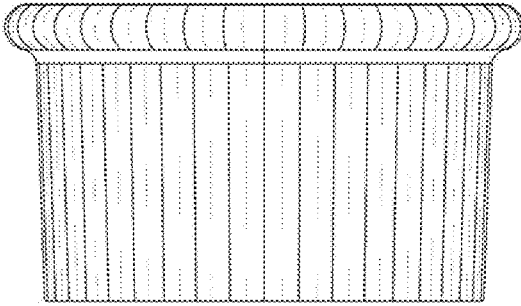

1.5

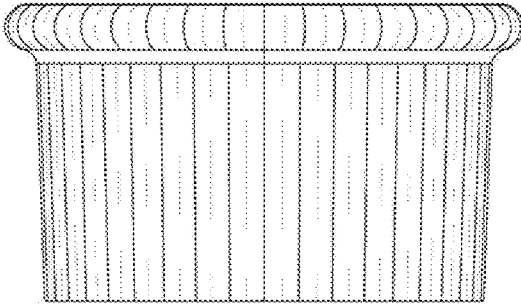

1.6

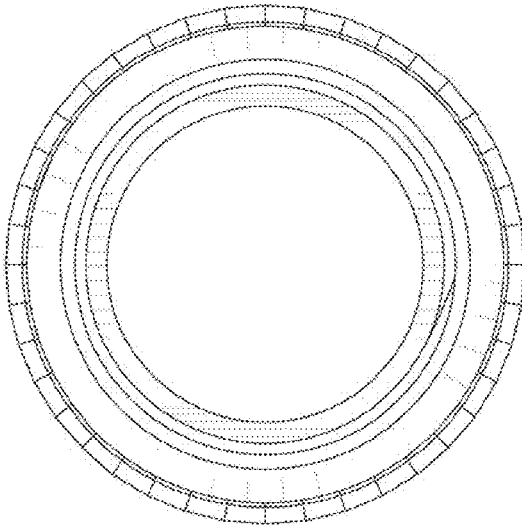

1.7

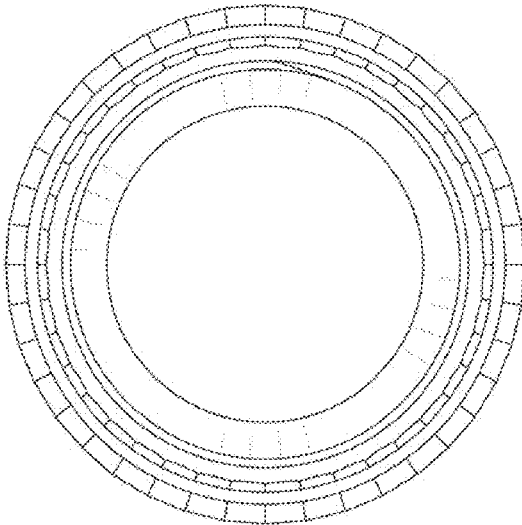

1.8

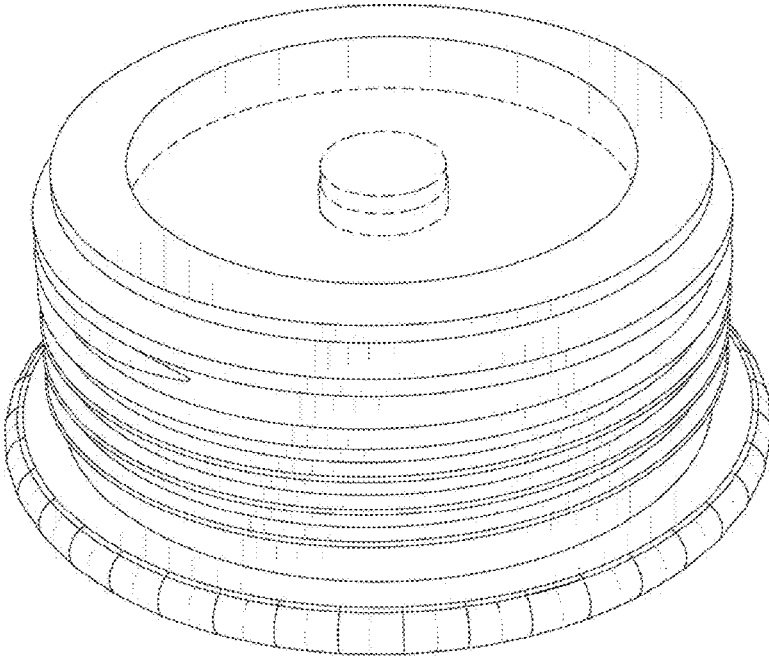

1.9

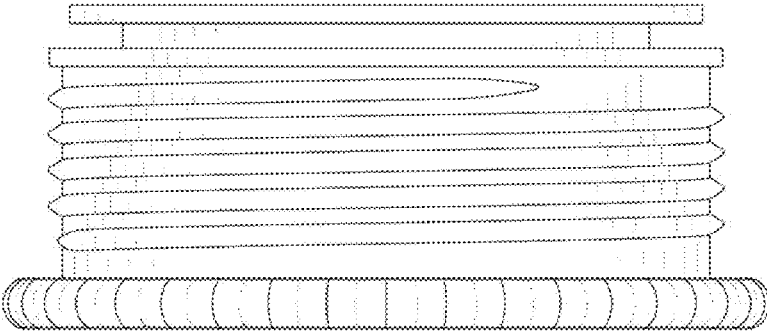

1.10

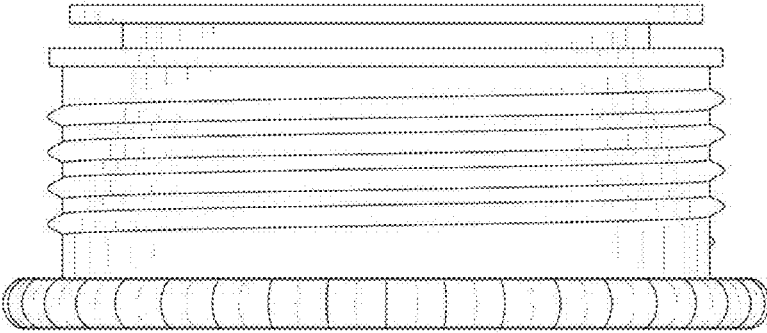

1.11

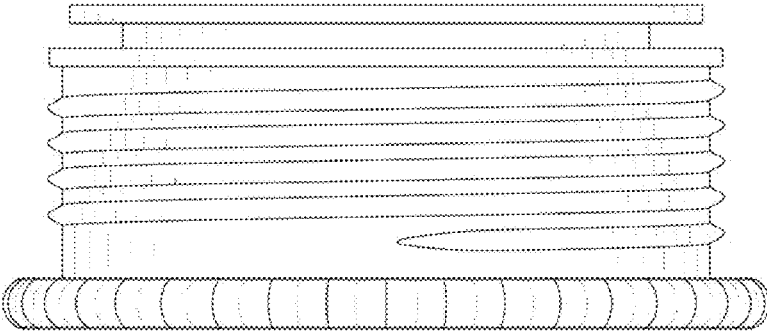

1.12

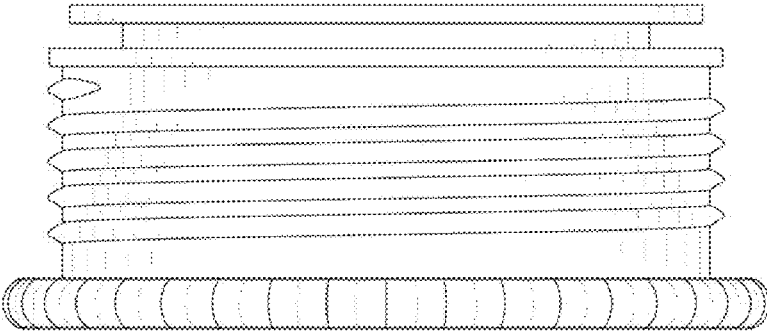

1.13

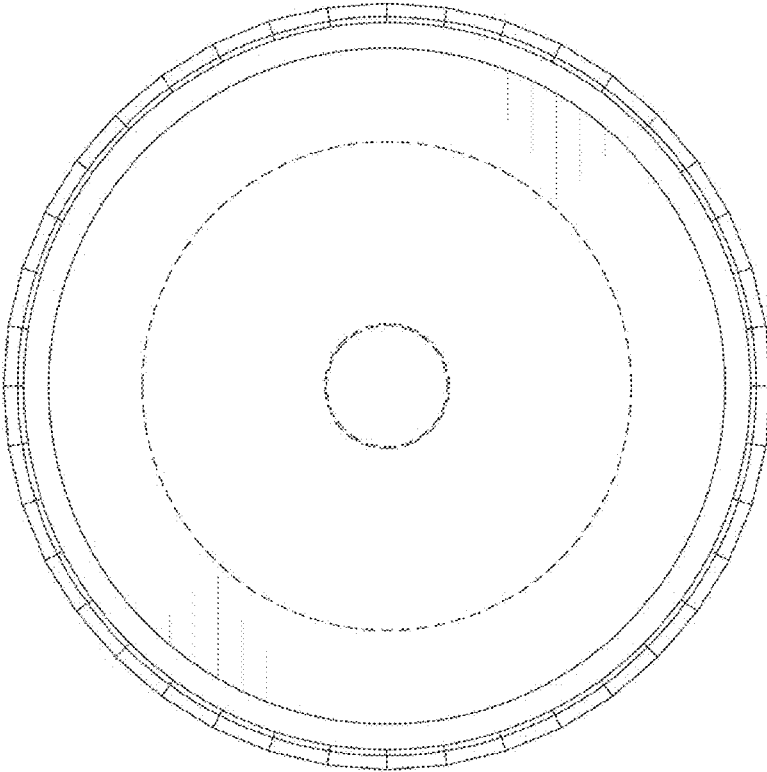

1.14

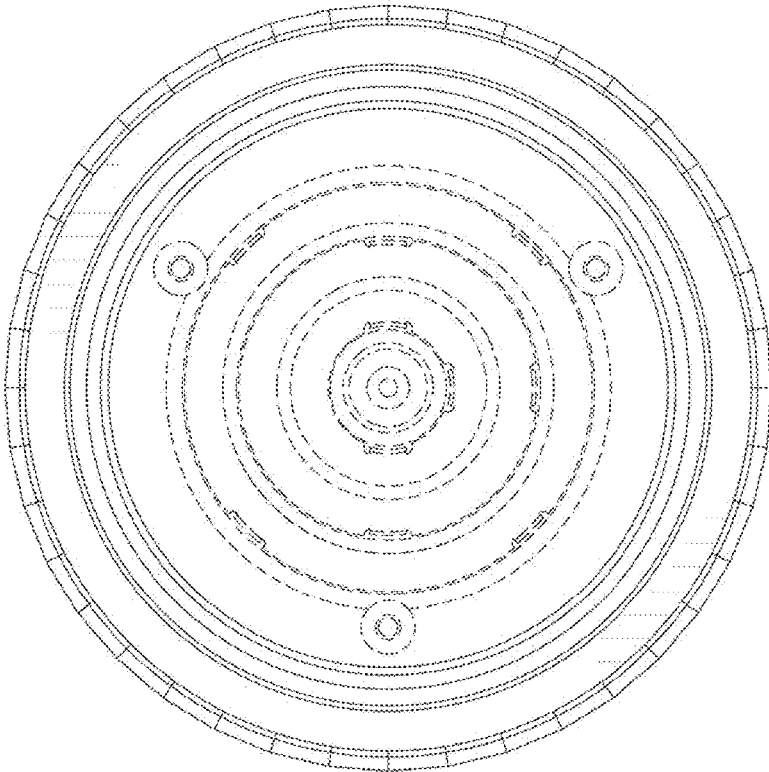

1.15

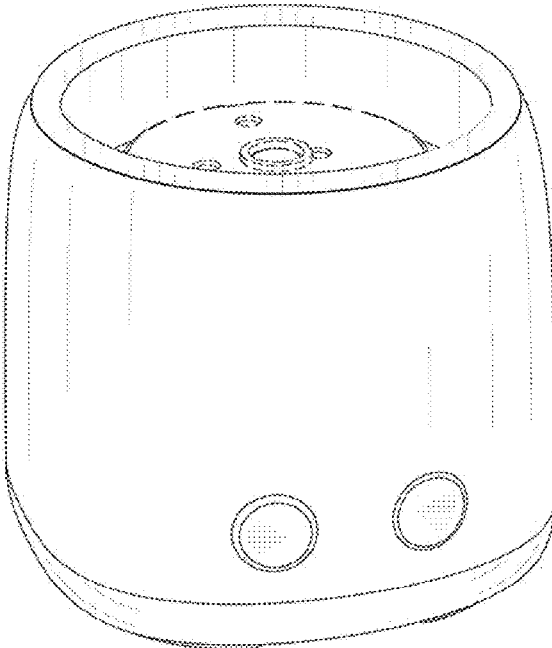

1.16

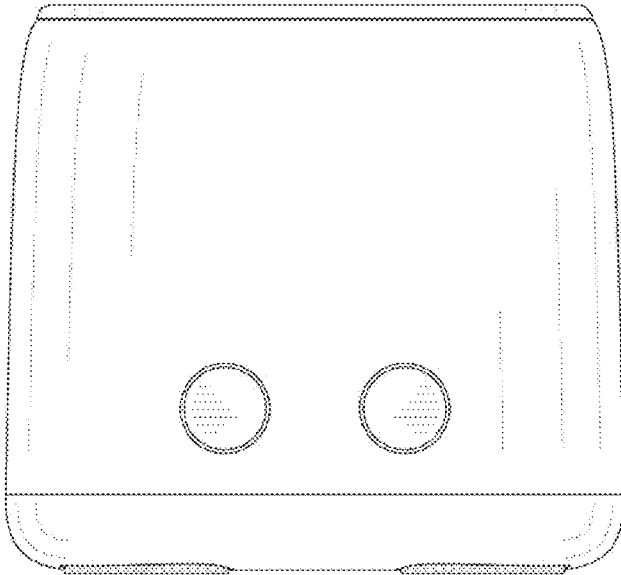

1.17

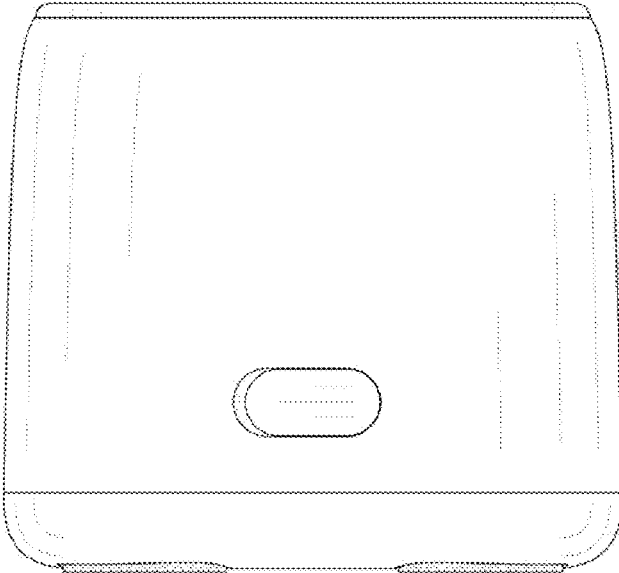

1.18

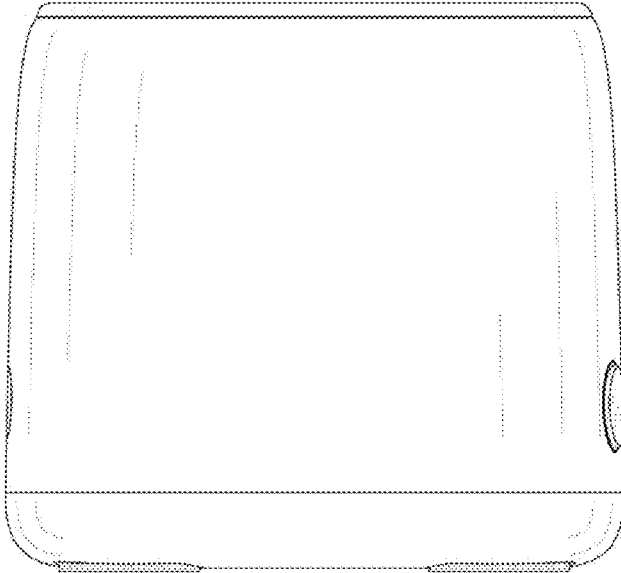

1.19

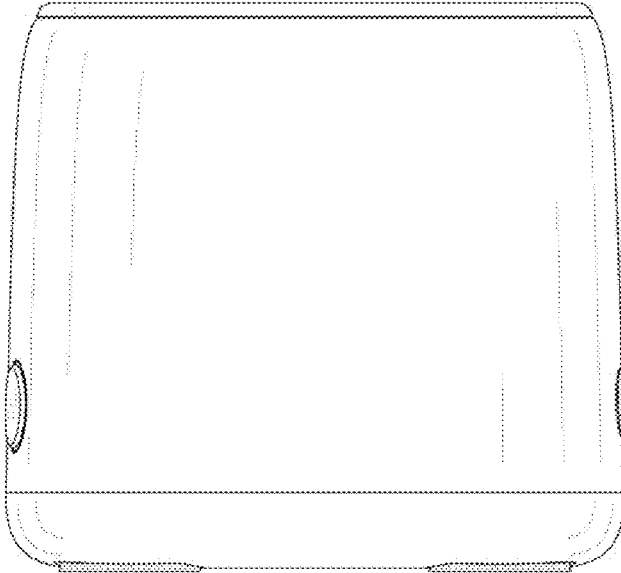

1.20

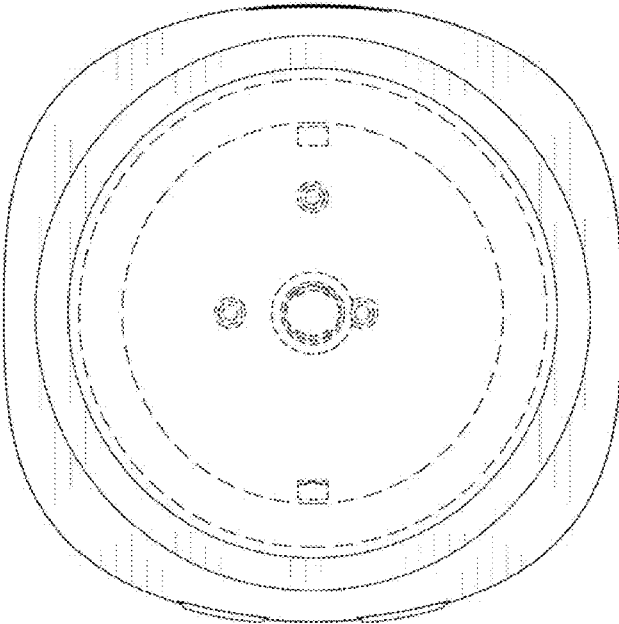

1.21

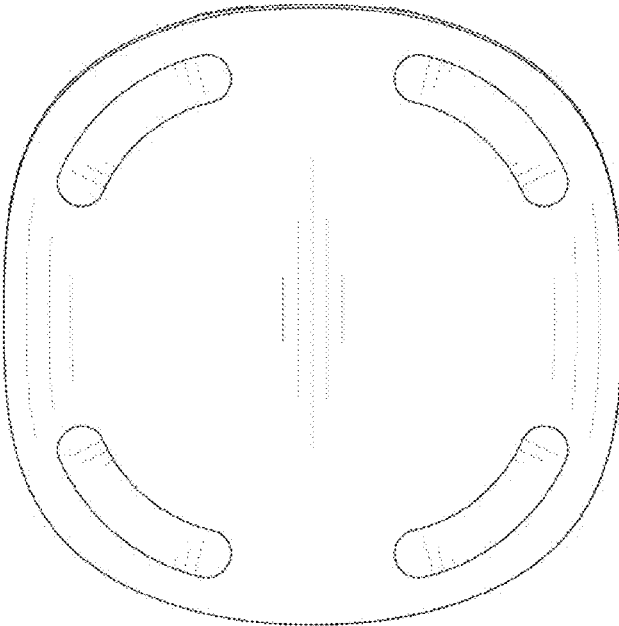

1.22

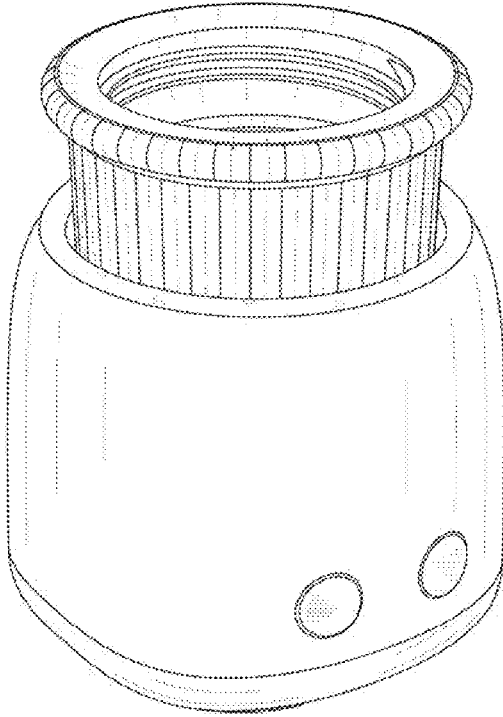

1.23

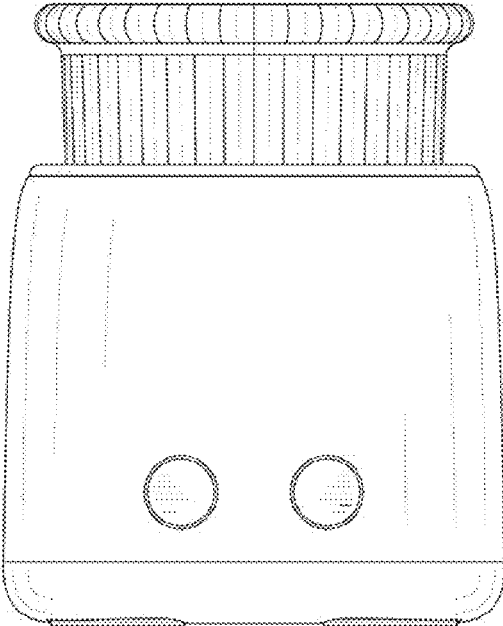

1.24

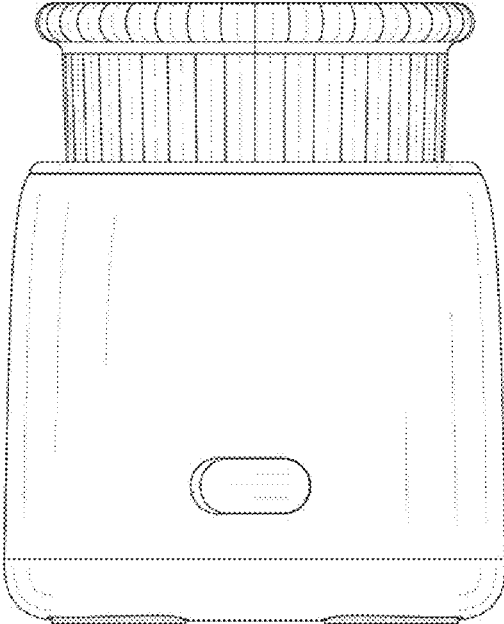

1.25

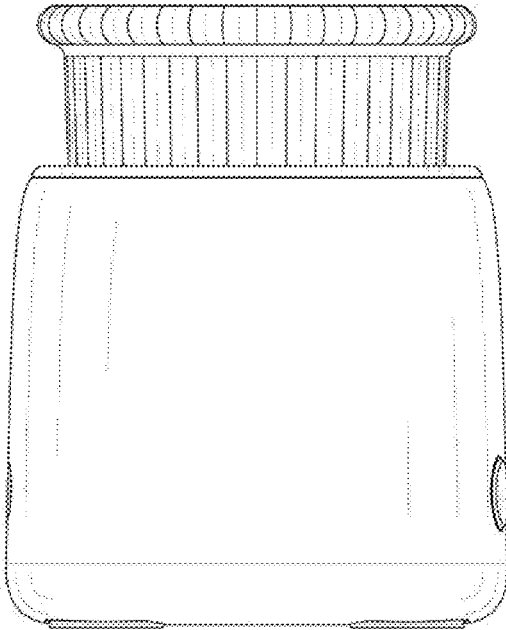

1.26

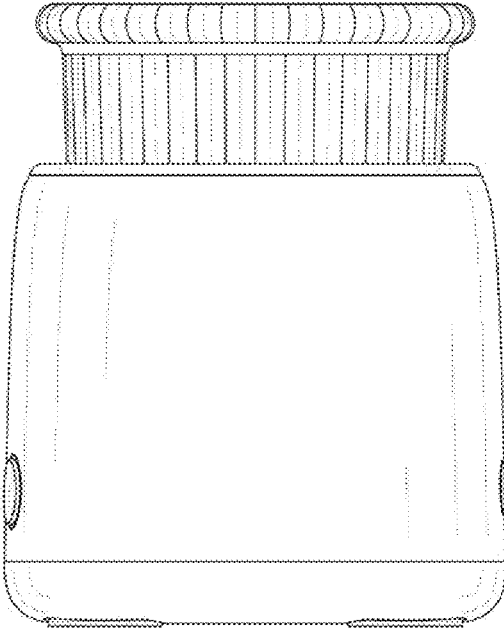

1.27

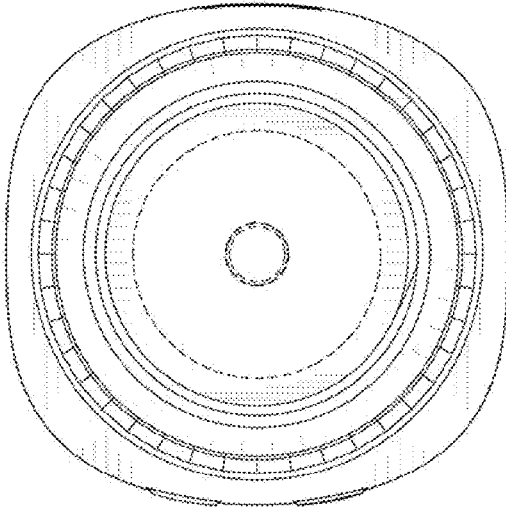

1.28

