

[54] **SOCCER TABLE WITH GOAL AND PENALTY OPENING**

[75] Inventor: **Lawrence T. Patterson, Jr.**, Cincinnati, Ohio

[73] Assignee: **Patterson International Corporation**, Cincinnati, Ohio

[22] Filed: **Feb. 26, 1970**

[21] Appl. No.: **14,502**

[52] U.S. Cl. .... **273/85 D, 273/122 R**

[51] Int. Cl. .... **A63f 7/06**

[58] Field of Search .... **273/85 G, 85 A, 85 B, 85 C, 273/85 D, 85 E, 94 G, 94 A, 94 B, 94 C, 94 D, 94 E, 11 C**

[56] **References Cited**

**UNITED STATES PATENTS**

1,934,381	11/1933	Slosson .....	273/85 D
2,574,363	11/1951	Wilhem .....	273/11 C
2,832,596	4/1958	Brown .....	273/85 D

**FOREIGN PATENTS OR APPLICATIONS**

765,266	3/1934	France .....	273/85 D
506,864	12/1954	Italy .....	273/85 D
627,688	5/1963	Belgium .....	273/85 D
506,585	5/1939	Great Britain .....	273/85 E
631,677	8/1963	Belgium .....	273/85 D

Primary Examiner—Paul E. Shapiro  
Attorney, Agent, or Firm—Melville, Strasser, Foster & Hoffman

[57] **ABSTRACT**

An improved game table having at least one penalty pocket adjacent each side of goal pockets, which goal pockets are centrally located in each of opposed end members on a playing surface. All the pockets are in communication with a common chamber positioned beneath the playing surface. Each penalty pocket comprises a perforation extending through at least a portion of its respective end member and leading to a forward portion of the chamber. A pair of baffles, positioned on each side of the common chamber, communicate with one of the goal pockets. A pivoted button member divides the common chamber into a rearward portion, which communicates with the goal pockets through the pairs of baffles, and the forward portion. Ducts communicate between each one of the penalty pockets and the forward portion of the common chamber. Balls in forward chamber portion are freely accessible from the exterior of the game table, but balls in the rearward portion are accessible only after operation of the pivoted button member which may be coin controlled.

**1 Claim, 6 Drawing Figures**

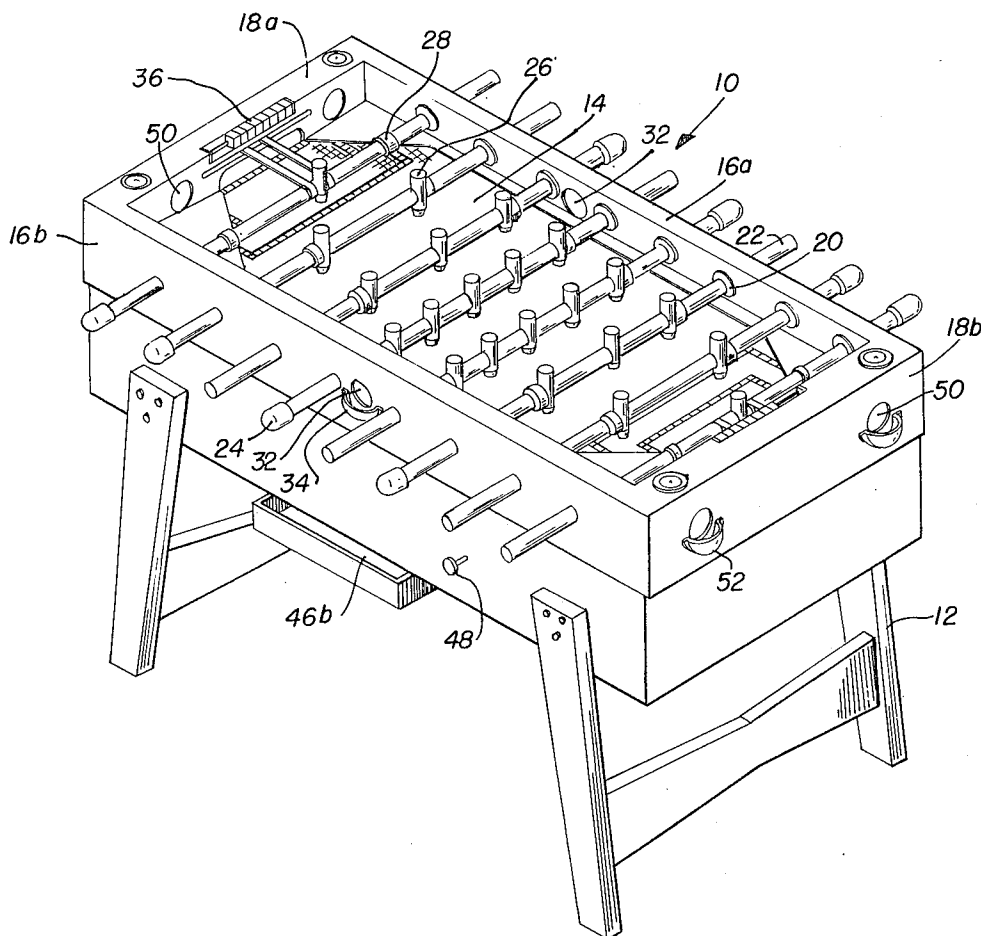

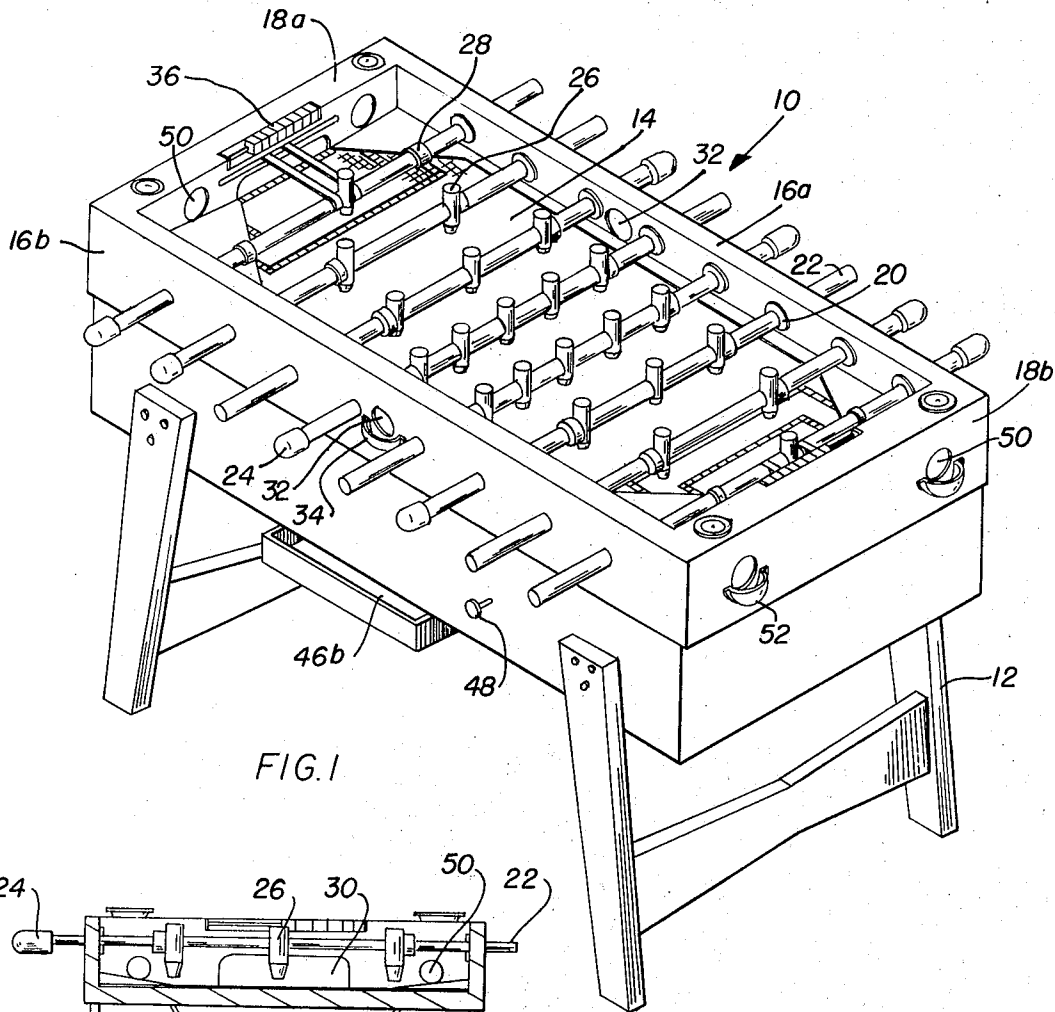

FIG. 1

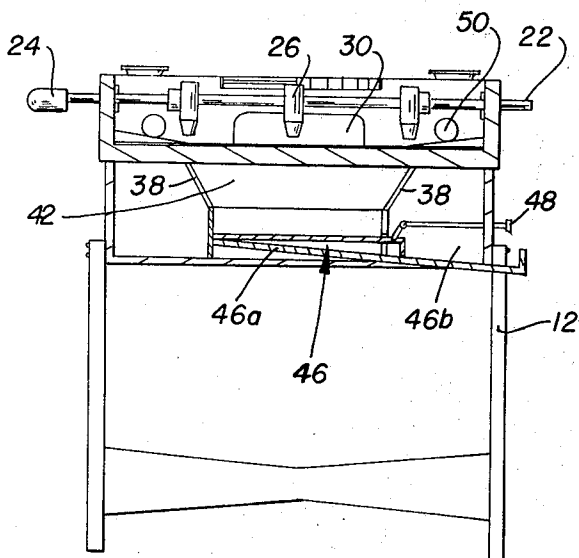

FIG. 3

INVENTOR/S  
Lawrence T. Patterson, Jr.

BY *Melville, Strasser, Foster and Hoffman*  
ATTORNEYS

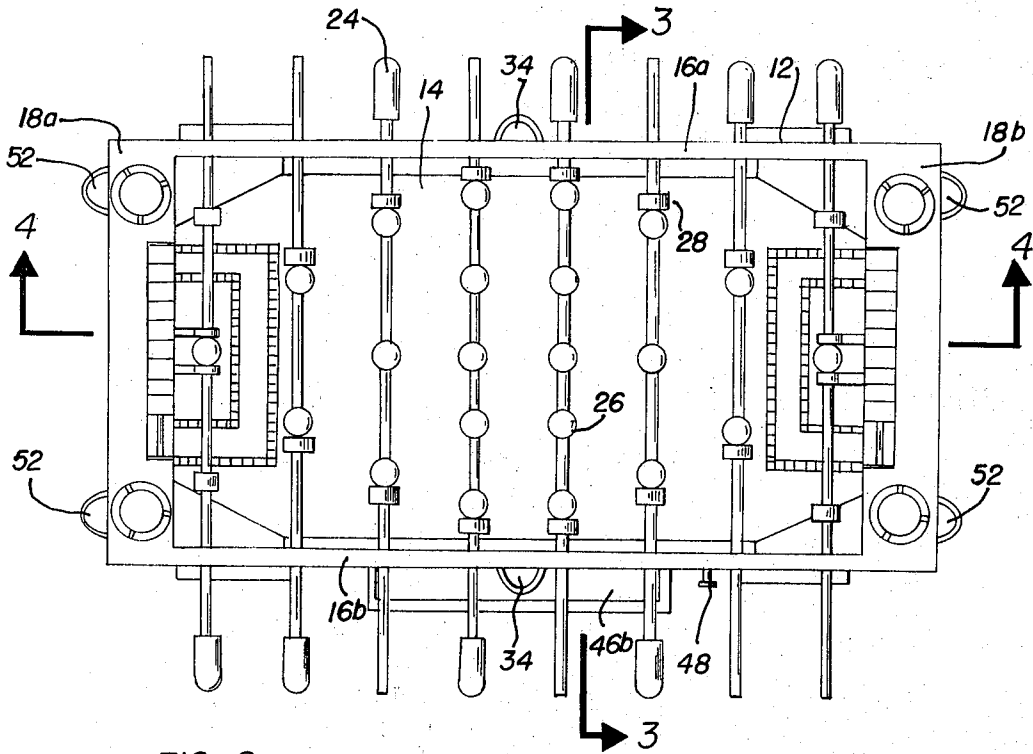

FIG. 2

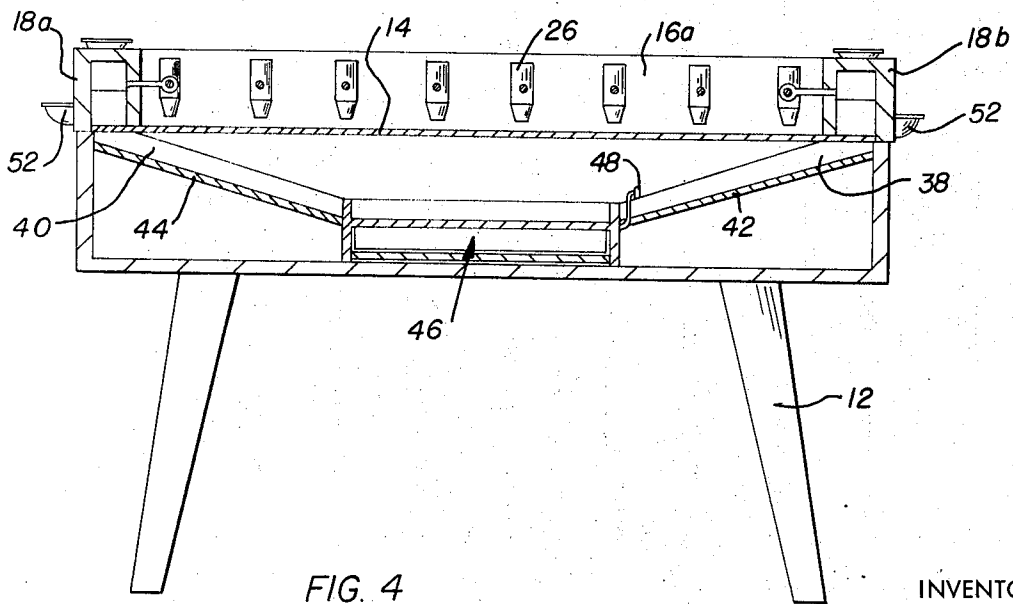

FIG. 4

INVENTOR/S  
Lawrence T. Patterson, Jr.

BY *Melville, Strasser, Foster and Hoffman*  
ATTORNEYS

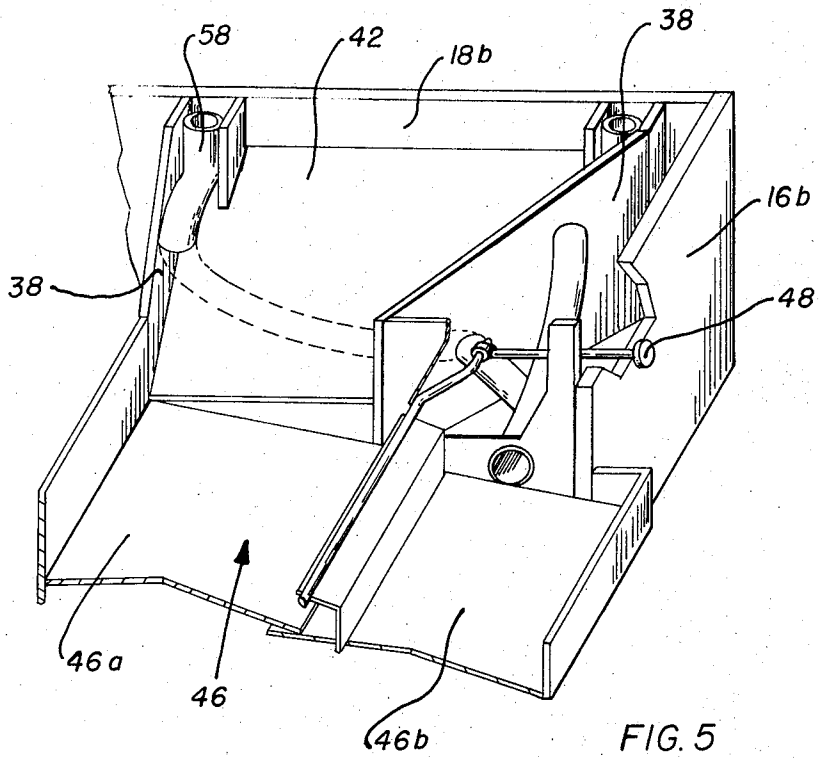

FIG. 5

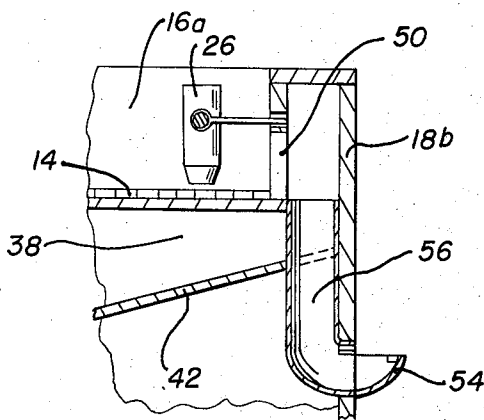

FIG. 6

INVENTOR/S

Lawrence T. Patterson, Jr.

BY *Melville, Strasser, Foster and Hoffman*  
ATTORNEYS

## SOCCER TABLE WITH GOAL AND PENALTY OPENING

### BACKGROUND OF THE INVENTION

#### 1. Field of the Invention

This invention relates to a game table on which a ball or the like is propelled from one end thereof to the other.

#### 2. Description of the Prior Art

Prior art game tables on which a ball or the like is propelled from one end thereof to the other have generally included a recessed playing surface having opposed side and end members thereon with a series of bars mounted parallel to each other and the end members through the side members. The bars are rotatable and movable longitudinally of the side members and normal thereto. A plurality of figurines are fixedly attached to the bars adjacent the playing surface. A goal pocket is centrally located in each of the end members, and retrieval means, including a common pocket, communicate with the goal pockets.

In operation, opposing players control the movement of the bars at each end of the game table, and thus the figurines in front of each goal pocket, and a ball or the like, which is placed on the recessed playing surface, is propelled from one end of the playing surface to the other, eventually being propelled into a goal pocket, which results in the scoring of a point for the propelling player.

The art has developed myriad variations of the aforementioned game table in order to constantly increase the skill of the game and the excitement of the players. However, while such variations have often required increased skill, the increased excitement of the players has generally been short lived.

Accordingly, it is an object of the present invention to provide an improved game table which will substantially increase the skill of the players as well as provide a continuing air of increased excitement.

### SUMMARY OF THE INVENTION

In its broadest application, the present invention comprises an improved game table having at least one penalty pocket adjacent each side of the goal pockets, which are centrally located in each of the end members on the recessed playing surface.

In one embodiment of the invention, each penalty pocket extends through the end members and is provided with a cup-shaped receiving member on the outside of the end member. The cup-shaped receiving members are preferably planar with the penalty pockets. However, they may also be positioned below the penalty pockets with duct means communicating between each cup-shaped member and its respective penalty pocket.

In still another embodiment of the present invention, duct means communicate between each of the penalty pockets and a common pocket, which is part of the retrieval means for the balls or the like after they have entered the goal pockets.

### BRIEF DESCRIPTION OF THE DRAWING

FIG. 1 is a perspective view of an improved game table according to the present invention.

FIG. 2 is a plan view of the improved game table.

FIG. 3 is a cross-sectional view taken on the line 3—3 of FIG. 2.

FIG. 4 is a cross-sectional view taken on the line 4—4 of FIG. 2.

FIG. 5 is an enlarged perspective view, partially in cross section, showing a second embodiment of the present invention.

FIG. 6 is a partial, cross-sectional view through one of the pocket penalties of the improved game table of the present invention illustrating still another embodiment thereof.

### DESCRIPTION OF THE PREFERRED EMBODIMENTS

Referring now to the drawings, and in particular to FIGS. 1 through 4, it will be seen that the game table 10 is provided with leg members 12 supporting a recessed playing surface 14. Opposed side members 16a and 16b and end members 18a and 18b are positioned on the playing surface. The side members 16a and 16b are provided with bearings 20 which are in alignment and in the examples shown number eight. The bearings 20 receive the bars or rods 22 to which are secured figurines 26. The figurines may, of course, represent any desired characters, such as, for example, football or soccer players. Additionally, they may be provided with identifying indicia representing well known professional teams. Handles 24 are also provided at the ends of selected bars 22. As can be seen, the bars 22, and thus the figurines 26, are rotatable and movable longitudinally of the side members 16a and 16b and normal thereto. Additionally, stops 28 are provided on the bars 22 to limit longitudinal movement to the distance between the stops 28 and the side members 16a and 16b.

A goal pocket 30 is centrally located in each of the end members 18a and 18b, and retrieval means, including a common pocket or chamber 46, communicate with the goal pockets 30. In a preferred embodiment, the common pocket 46 is centrally positioned beneath the playing surface 14 and extends outwardly, as at 46b, beyond one of the side members 16b. The retrieval means also includes a pair of baffles 38 on either side of the common pocket 46 which communicate with one of the goal pockets 30, each of the pairs of baffles 38 being mounted on one inclined surface 42 which leads from one of the goal pockets 30 to the common pocket 46. A pivoted button member 48 divides the common pocket 46 into a first portion 46a, which communicates with the goal pockets 30 through the pairs of baffles 38, and a second portion 46b, which includes the outwardly and extending portion.

The game table 10 also includes a scoring device 36, one of which is secured on each end member 18a and 18b.

According to the present invention, the game table 10 is provided with at least one penalty pocket 50 adjacent each side of the goal pockets 30. Each penalty pocket 50 comprises a perforation extending through at least a portion of its respective end member 18a or 18b near a corner thereof and leading to ball retaining means. The adjacent corners of the recessed playing surface 14 are upturned and the perforations are flush therewith. In one embodiment of the invention, as shown in FIGS. 1 through 4, the perforations 50 extend completely through their respective end members 18a and 18b and the ball retaining means for each perforation comprises a cup-shaped receiving member 52 mounted on the outside surface of the end members

18a and 18b. The cup-shaped receiving members 52 are preferably planar with the penalty pockets 50. However, they may also be positioned below the perforations, as shown at 54, in FIG. 6, and duct means 56 may be provided to communicate between the perforations 50 and the cup-shaped receiving members 54.

In still another embodiment of the present invention, as shown in FIG. 5, the ball retaining means comprises duct means 58 communicating between each of the penalty pockets 50 and the common pocket 46. Preferably, the duct means 58 communicate between each of the penalty pockets 50 and the second portion 46b of the common pocket 46.

The game table 10 of the present invention is operated by opposing players who control the movement of the bars 22, and thus the figurines 26 thereon, in front of each goal pocket 30. The game starts by placing a ball in one of the cup members 34 on the side members 16a and 16b. The cup members 34 communicate through the openings 32 with the recessed playing surface 14. When the ball or the like is on the playing surface 14, it is propelled back and forth by movement of the figurines 26, which may be rotated or moved longitudinally through movement of the bars 22. If one player succeeds in propelling the ball through the opposing player's goal pocket 30, the propelling player has scored a point. Additionally, if the ball is propelled through one of the penalty pockets or perforations 50, the opposing player is penalized, in that the ball is placed in front of the opposing player's goal pocket 30 and the player who propelled the ball into the penalty pocket 50 is allowed to place it in front of the goal pocket 30 for a free chance at scoring a goal.

As can be seen from the drawings, when the ball enters one of the goal pockets 30, it is directed into the portion 46a of the common pocket or chambers 46, and may not be used again by the players until such time as the buttom member 48 is depressed and the ball is allowed to roll into the portion 46b of the common pocket 46. However, if the ball is propelled into any one of the penalty pockets or perforations 50, and thus into the ball receiving means, such as the cup-shaped receiving members 52 or 54 of either the embodiment of FIGS. 1 through 4, or the embodiment of FIG. 6, respectively, the players may continue to use this ball. This, of course, is also true with respect to the embodiment of FIG. 5, because the ball receiving means includes the duct means 58 which directs the ball from the penalty pockets 50 into the portion 46b of the common pocket or chambers 46.

It has been found that the improved game table 10 of the present invention provides players with new stimulation and increased enthusiasm. Accordingly, players will continue to play the game and to challenge others because the game provides eye to eye — head to head competition.

While certain preferred embodiments of the invention have been specifically illustrated and described, it is understood that the invention is not limited thereto, as many variations will be apparent to those skilled in the art, and the invention is to be given its broadest interpretation within the terms of the following claims.

The embodiments of the invention in which an exclusive property or privilege is claimed are defined as follows:

1. In a game table of the type having a recessed playing surface and a plurality of balls to be used thereon, opposed side and end members on said playing surface, a series of bars mounted parallel to each other and said end members through said side members, said bars being rotatable and movable longitudinally of said side members, and normal thereto, a plurality of figurines fixedly attached to said bar members adjacent said playing surface, a goal pocket located in each of said end members, and a common chamber communicating with said goal pockets; the improvement, in combination therewith, comprising at least one penalty pocket adjacent each side of said goal pockets, each penalty pocket comprising a perforation extending through at least a portion of its respective end member near a corner thereof and leading to ball retaining means, the adjacent corners of said recessed playing surface being upturned and said perforations being flush therewith, said common chamber being centrally positioned beneath said playing surface and extending outwardly beyond one of said side members, a pair of baffles positioned on each side of said common chamber which communicate with one of said goal pockets, each of said pairs of baffles being mounted on an inclined surface leading from one of said goal pockets to said common chamber, a pivoted button member dividing said common chamber into a first portion, which communicates with said goal pockets through said pairs of baffles, and a second portion comprising said ball retaining means, said second portion including said outwardly extending portion and duct means communicating between each one of said perforations and said second portion of said common chamber.

\* \* \* \* \*

50

55

60

65