

**(19) AUSTRALIAN PATENT OFFICE**

(54) Title  
Dual zone feedwell for a thickener

(51)<sup>6</sup> International Patent Classification(s)  
**B01D** 21/01 (2006.01) <sup>SBMEP</sup> **B01D**  
**B01D** 21/02 (2006.01) 21/18  
**B01D** 21/18 (2006.01) 20060101ALI2005122  
**B01D** 21/24 (2006.01) <sup>OBMJP</sup> **B01D**  
**C02F** 1/52 (2006.01) 21/24  
**B01D** 21/01 20060101ALI2005122  
20060101AFI2005122 <sup>OBMJP</sup> **C02F**  
<sup>OBMJP</sup> **B01D** 1/52  
21/02 20060101ALI2005122  
20060101ALI2005100 <sup>OBMJP</sup>  
PCT/AU03/00285

(21) Application No: 2003208184 (22) Application Date: 2003 .03 .11

(87) WIPO No: W003/078021

(30) Priority Data

(31) Number	(32) Date	(33) Country
PS 1188	2002 .03 .19	<b>AU</b>

(43) Publication Date : 2003 .09 .29

(43) Publication Journal Date : 2003 .11 .06

(71) Applicant(s)  
Outotec Oyj

(72) Inventor(s)  
Taylor, David John Buchanan

(74) Agent/Attorney  
Shelston IP, 60 Margaret Street, Sydney, NSW, 2000

(56) Related Art  
US 5147556  
SU 1506823  
WO 01/19489

(12) INTERNATIONAL APPLICATION PUBLISHED UNDER THE PATENT COOPERATION TREATY (PCT)

(19) World Intellectual Property Organization  
International Bureau



(43) International Publication Date  
25 September 2003 (25.09.2003)

PCT

(10) International Publication Number  
**WO 03/078021 A1**

- (51) International Patent Classification: **B01D 21/24**
- (21) International Application Number: PCT/AU03/00285
- (22) International Filing Date: 11 March 2003 (11.03.2003)
- (25) Filing Language: English
- (26) Publication Language: English
- (30) Priority Data:  
PS 1188 19 March 2002 (19.03.2002) AU
- (71) Applicant (for all designated States except US): **OUT-OKUMPU OYJ** [FI/FI]; Riihitontuntie 7 D, FIN-02200 Espoo (FI).
- (72) Inventor; and  
(75) Inventor/Applicant (for US only): **TAYLOR, David, John, Buchanan** [AU/AU]; 22 Henry Street, Gordon, NSW 2072 (AU).
- (74) Agent: **BALDWIN SHELSTON WATERS**; 60 Margaret Street, Sydney, NSW 2000 (AU).
- (81) Designated States (national): AE, AG, AI, AM, AT, AU, AZ, BA, BB, BG, BR, BY, BZ, CA, CH, CN, CO, CR, CU, CZ, DE, DK, DM, DZ, EC, EE, ES, FI, GB, GD, GE, GH, GM, HR, HU, ID, IL, IN, IS, JP, KE, KG, KP, KR, KZ, LC, LK, LR, LS, LT, LU, LV, MA, MD, MG, MK, MN, MW, MX, MZ, NI, NO, NZ, OM, PH, PL, PT, RO, RU, SC, SD, SE, SG, SK, SL, TJ, TM, TN, TR, TT, TZ, UA, UG, US, UZ, VC, VN, YU, ZA, ZM, ZW.
- (84) Designated States (regional): ARIPO patent (GH, GM, KE, LS, MW, MZ, SD, SL, SZ, TZ, UG, ZM, ZW), Eurasian patent (AM, AZ, BY, KG, KZ, MD, RU, TJ, TM), European patent (AT, BE, BG, CH, CY, CZ, DE, DK, EE, ES, FI, FR, GB, GR, HU, IE, IT, LU, MC, NL, PT, RO, SE, SI, SK, TR), OAPI patent (BF, BJ, CF, CG, CI, CM, GA, GN, GQ, GW, ML, MR, NE, SN, TD, TG).
- Declarations under Rule 4.17:**  
— as to applicant's entitlement to apply for and be granted a patent (Rule 4.17(ii)) for the following designations AE, AG, AL, AM, AT, AU, AZ, BA, BB, BG, BR, BY, BZ, CA, CH, CN, CO, CR, CU, CZ, DE, DK, DM, DZ, EC, EE, ES, FI, GB, GD, GE, GH, GM, HR, HU, ID, IL, IN, IS, JP, KE, KG, KP, KR, KZ, LC, LK, LR, LS, LT, LU, LV, MA, MD, MG, MK, MN, MW, MX, MZ, NI, NO, NZ, OM, PH, PL, PT, RO, RU.

[Continued on next page]

(54) Title: DUAL ZONE FEEDWELL FOR A THICKENER

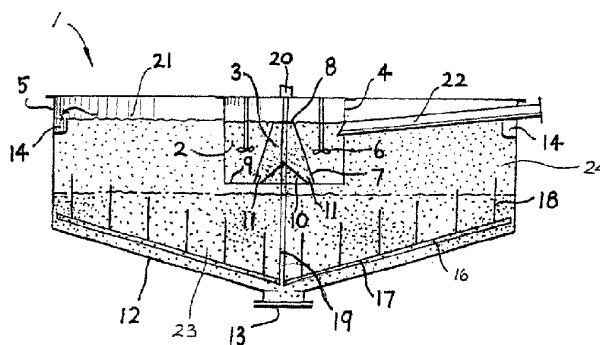

(57) Abstract: The invention provides an extraction device (1) for liquid suspensions and pulps and is designed for use in the field of mineral processing. The extraction device includes two adjacent upstream and downstream concentric chambers (2) and (3) defining a feedwell (4). The feedwell is centrally located upstream of a third chamber in the form of a thickening tank (5). All three chambers are in sequential unidirectional fluid flow relationship such that feed liquid flows firstly from chamber (2) to chamber (3) and then to the tank (5).

WO 03/078021 A1



SC, SD, SE, SG, SK, SI, TJ, TM, TN, TR, TT, TZ, UA, UG, UZ, VC, VN, YU, ZA, ZM, ZW, ARIPO patent (GH, GM, KE, IS, MW, MZ, SD, SL, SZ, TZ, UG, ZM, ZW), Eurasian patent (AM, AZ, BY, KG, KZ, MD, RU, TJ, TM), European patent (AT, BE, BG, CH, CY, CZ, DE, DK, EE, ES, FI, FR, GB, GR, HU, IE, IT, LU, MC, NL, PT, RO, SE, SI, SK, TR), OAPI patent (BF, BJ, CF, CG, CI, CM, GA, GN, GQ, GW, ML, MR, NE, SN, TD, TG)

— of inventorship (Rule 4.17(iv)) for US only

**Published:**

— with international search report

For two-letter codes and other abbreviations, refer to the "Guidance Notes on Codes and Abbreviations" appearing at the beginning of each regular issue of the PCT Gazette.

TITLE: DUAL ZONE FEEDWELL FOR A THICKENERFIELD OF THE INVENTION

The present invention relates to separation devices for liquid suspensions and pulps and in particular to a feedwell for use in such devices. It has been developed  
5 primarily for use in thickeners and will be described hereinafter with reference to this application. However, it will be appreciated that the invention is not limited to this particular field of use.

BACKGROUND OF THE INVENTION

The following discussion of the prior art is intended to present the invention in an  
10 appropriate technical context and allow its significance to be properly appreciated. Unless clearly indicated to the contrary, however, reference to any prior art in this specification should not be construed as an admission that such art is widely known or forms part of common general knowledge in the field.

Known separation devices of this type typically include a thickening tank and a  
15 feedwell disposed generally within the tank to contain feed slurry. The feedwell is comprised of a single chamber having an inlet for receiving feed slurry and at least one restricted outlet for directing the slurry into the thickening tank. The feedwell is configured to reduce the turbulence of the incoming feed stream, to allow reagents to be mixed into the slurry, and to allow for reaction between reagents and the feed material  
20 before the treated slurry is discharged into the thickening tank. The configuration of the feedwell also promotes even distribution of slurry flowing from its outlet into the thickening tank.

Known extraction devices do not optimise the mixing and distribution of liquid entering the thickening tank from the feedwell outlet. They suffer from back-mixing of  
25 liquid from the thickening tank into the feedwell as well as short-circuiting of liquid flow from the feedwell itself. Another shortcoming, in some circumstances, is that insufficient residence time is provided to allow for optimum reaction of flocculants and reagents. Similarly, the residence time is often insufficient to allow for staged addition of reagents, requiring additional upstream tanks to be added, in turn increasing cost and  
30 space requirements.

It is an object of the invention to overcome or ameliorate one or more of the deficiencies of the prior art, or at least to provide a useful alternative.

#### DISCLOSURE OF THE INVENTION

According to a first aspect of the invention, there is provided a feedwell for a  
5 separation device, said feedwell including at least two adjacent upstream and  
downstream substantially concentric chambers, said chambers being in sequential  
unidirectional fluid flow relationship such that fluid entering said feedwell overflows  
from said upstream chamber into said downstream chamber for subsequent discharge  
from an outlet thereof into the separation device, the downstream chamber being at least  
10 partially defined by sidewalls diverging toward the outlet.

Preferably, the inlet to the downstream chamber is located centrally above the  
floor of the upstream chamber. In a particularly preferred form, the upstream chamber is  
cylindrical and the downstream chamber is concentrically frusto-conical with the  
sidewalls of the downstream chamber diverging downwardly and outwardly from its  
15 inlet.

Preferably, the feedwell includes a downwardly divergent deflection surface at  
least partially defining a restricted outlet for restricting the flow of fluid from the  
downstream chamber. In one preferred form, the downwardly divergent deflection  
surface is part of a concentrically nested deflection cone forming the floor of the  
20 downstream chamber and defining an annular outlet from the downstream chamber.  
More preferably, the annular outlet has an area substantially less than the mean cross-  
sectional area of the downstream chamber partially to restrict the flow of liquid from the  
feedwell. Preferably, the upstream chamber includes at least one agitator for mixing  
floculant into a liquid suspension or pulp.

25 Preferably, the unidirectional fluid flow relationship between said upstream and  
downstream chambers is gravity-driven.

Preferably, the upstream and downstream chambers have a common sidewall  
partially defining the restricted outlet of the downstream chamber. Preferably, the  
common sidewall is substantially frusto-conical.

Preferably, the separation device is a thickener.

According to a second aspect of the invention, there is provided a separation device for a liquid suspension including a feedwell as defined above in the first aspect, said feedwell being centrally located upstream of a third chamber defining a thickening tank, said three chambers being in sequential unidirectional fluid flow relationship.

In a preferred form, the third chamber includes a circumferential overflow launder for decanting excess overflow liquor from the thickening tank to a discharge pipe.

Preferably, a rake assembly is centrally rotatably mounted within the thickening tank. Preferably, the rake assembly includes a plurality of radially extending rake arms each fixedly connected at one end to a central hub. More preferably, a plurality of rake blades is fixedly connected to each arm. Preferably, each blade extends axially into the tank such that as the rake rotates, the blades sweep through the fluid in the tank.

According to a third aspect, the invention provides a method for separating liquid suspensions or pulps in a thickener, said method including the steps of:

- 15 providing a thickening tank adapted to facilitate settling;
- providing a feedwell having an upstream chamber and a downstream chamber, disposed such that fluid entering said feedwell overflows from said upstream chamber into said downstream chamber from an outlet thereof and then into said thickening tank, the downstream chamber being at least partially defined by sidewalls diverging toward
- 20 the outlet;
- directing a liquid suspension or pulp into said upstream chamber;
- allowing said liquid suspension or pulp to overflow from said upstream chamber into said downstream chamber; and
- allowing said liquid suspension or pulp to flow from said downstream chamber
- 25 into said thickening tank to facilitate separation.

Preferably, the method includes the step of providing a restricted outlet from said downstream chamber, thereby partially to restrict the flow of the liquid suspension or pulp from the feedwell. More preferably, a downwardly divergent deflection surface at least partially defines the restricted outlet. In one preferred form, the method includes

30 the step of providing the downwardly divergent deflection surface as part of a

concentrically nested deflection cone forming a floor of the downstream chamber and defining an annular outlet from the downstream chamber.

Preferably, the method an inlet to the downstream chamber is located generally centrally above a floor of the upstream chamber and fluid flowing from said upstream chamber overflows into said downstream chamber.

Preferably, in the method the upstream chamber is generally cylindrical.

Preferably, in the method the downstream chamber is generally concentrically frusto-conical with sidewalls of the downstream chamber diverging downwardly and outwardly from an inlet thereto.

10 Preferably, in the method the sequential fluid flow is gravity-driven.

Preferably, the method includes the step of providing said upstream and downstream chambers with a common sidewall partially defining the restricted outlet of the downstream chamber. Preferably, the common sidewall is substantially frusto-conical.

15 Preferably, the method includes the step of mixing flocculant into the liquid suspension or pulp in the upstream chamber.

#### BRIEF DESCRIPTION OF THE DRAWINGS

A preferred embodiment of the invention will now be described, by way of example only, with reference to the accompanying drawings in which:

20 Figure 1 is a plan view of a thickener for a liquid suspension according to the invention;

Figure 2 is an offset sectional view of the thickener, taken on line 2-2 of Figure 1; and

Figure 3 is a pictorial perspective view of a feedwell according to the invention.

PREFERRED EMBODIMENTS OF THE INVENTION

A preferred application of the invention is in the fields of mineral processing, separation and extraction, whereby finely ground ore is suspended as pulp in a suitable liquid medium such as water at a consistency which permits flow, and settlement in quiescent conditions. The pulp is precipitated from the suspension by a combination of chemical and mechanical processes. Initially, coagulant is added and mixed into the suspension in a first chamber, followed by the addition of flocculant in a second chamber. The suspension is then carefully mixed to facilitate the clumping together of solid particles, eventually forming larger denser particles that are precipitated out of suspension.

Referring to the drawings, the extraction device 1 includes two adjacent upstream and downstream concentric chambers 2 and 3 defining a feedwell 4. The feedwell is centrally located upstream of a third chamber in the form of a thickening tank 5. All three chambers are in sequential unidirectional fluid flow relationship such that feed liquid flows firstly from chamber 2 to chamber 3 and then to the tank 5.

In this embodiment, the first chamber 2 is right-cylindrical in shape and includes two agitators 6 for mixing reagents into the liquid suspension and for preventing solids from settling onto the floor of the chamber. Chamber 3 is located centrally within chamber 2 and is frusto-conical in shape, with its sidewall 7 diverging downwardly and outwardly from inlet 8. The inlet is located centrally above the floor 9 of chamber 2.

A deflection cone 10 is located internally of chamber 3 and forms its floor. The space between the chamber sidewall 7 and the deflection cone 10 defines a restricted annular outlet 11 from chamber 3 into the tank 5. This outlet 11 has an area substantially less than the mean cross-sectional area of chamber 3 to restrict the flow of liquid between feedwell 4 and tank 5, thereby promoting smooth, non-turbulent flow and homogenous distribution of liquid within the tank.

The tank 5 is substantially right-cylindrical and in this embodiment is formed of reinforced concrete. The tank includes a downwardly sloping frusto-conical floor 12 for directing precipitated pulp towards an underflow withdrawal pipe 13. The tank also



includes an inwardly directed circumferential overflow launder 14 for decanting dilute overflow liquor from the thickening tank into a discharge pipe 15.

5 A rake 16 is centrally rotatably mounted within the tank 5. The rake includes a plurality of radially extending rake arms 17, each supporting a plurality of fixedly connected rake blades 18. The blades extend axially into the tank such that as the rake 16 rotates, the blades sweep through the fluid in the tank. This sweeping assists in the release of water from the slurry in the bed, thereby increasing its density. The rake is mounted on a centrally located drive-shaft 19 driven by a motor 20 and an associated gearbox (not shown).

10 In use, the fluid level 21 of tank 5 is located above the level of outlet 11 from chamber 3. The feed liquid enters chamber 2 through an inlet 22 and reagents are added according to a predetermined dosage rate. The volume of slurry in chamber 2 gradually increases, thereby providing sufficient residence time for reaction of the reagents until they overflow into the inner chamber 3. The slurry entering chamber 3 may be dosed  
15 with a different reagent to that used in chamber 2, or it may be dosed with more of the same reagent, thus allowing for staged addition. It then flows downwardly under gravity towards the deflection cone 10, which gradually disperses the liquid radially outwardly through the outlet 11 into the surrounding tank.

20 In the tank, the precipitate in the incoming feed stream settles to form a relatively dense bed of thickened pulp 23 that displaces an upper layer of relatively dilute liquid 24 towards the top of the tank. The thickened pulp 23 is drawn off from below through the underflow withdrawal pipe 13, while the dilute liquor is progressively drawn off through the overflow launder.

25 In another feedwell embodiment (not shown), the first chamber is frusto-conical, with its sidewalls diverging radially inwardly from its floor to an outlet at its peak. This first chamber is located centrally within a second right-cylindrical chamber and fluid leaves this second chamber through an annular outlet defined by the space between the respective chamber walls.

30 It will be appreciated that the illustrated device provides improved mixing and distribution of fluid entering the thickening tank from the feedwell outlet. The device

also reduces the incidence of back-mixing of fluid from the thickening tank into the feedwell, allows for staged addition of reagents, as well as reducing short-circuiting of fluid flow from the feedwell itself. The concentric configuration of the device also reduces the space that it occupies within the tank. In all these respects, the invention  
5 represents a practical and commercially significant improvement over the prior art.

Although the invention has been described with reference to specific examples, it will be appreciated by those skilled in the art that the invention may be embodied in many other forms.

THE CLAIMS DEFINING THE INVENTION ARE AS FOLLOWS:-

1. A feedwell for a separation device, said feedwell including:  
at least two adjacent upstream and downstream substantially concentric chambers, said chambers being in sequential unidirectional fluid flow relationship, such  
5 that fluid entering said feedwell overflows from said upstream chamber into said downstream chamber for subsequent discharge from an outlet thereof into the separation device, the downstream chamber being at least partially defined by sidewalls diverging toward the outlet.
2. A feedwell according to claim 1, wherein an inlet to the downstream chamber is  
10 located generally centrally above a floor of the upstream chamber.
3. A feedwell according to claim 1 or claim 2, wherein the upstream chamber is generally cylindrical.
4. A feedwell according to any one of the preceding claims, wherein the  
15 downstream chamber is generally concentrically frusto-conical with sidewalls of the downstream chamber diverging downwardly and outwardly from an inlet thereto.
5. A feedwell according to any one of the preceding claims, including a downwardly divergent deflection surface at least partially defining a restricted outlet for restricting the flow of fluid from the downstream chamber.
6. A feedwell according to claim 5, wherein the downwardly divergent deflection  
20 surface is part of a concentrically nested deflection cone forming a floor of the downstream chamber and defining an annular outlet from the downstream chamber.
7. A feedwell according to claim 6, wherein the annular outlet has an area substantially less than a mean cross-sectional area of the downstream chamber, thereby partially to restrict the flow of liquid from the feedwell.
- 25 8. A feedwell according to any one of the preceding claims, wherein the upstream chamber includes at least one agitator for mixing flocculant into a liquid suspension or pulp.

9. A feedwell according to any one of the preceding claims, wherein said unidirectional fluid flow relationship between said upstream and downstream chambers is gravity-driven.
10. A feedwell according to any one of claims 5 to 9, wherein said upstream and downstream chambers have a common sidewall partially defining the restricted outlet of the downstream chamber.
11. A feedwell according to claim 10, wherein said common sidewall is substantially frusto-conical.
12. A feedwell according to any one of the preceding claims, wherein the separation device is a thickener.
13. A separation device for liquid suspensions or pulps, said device including a feedwell as defined in any one of claims 1 to 12, and being centrally located upstream of a third chamber defining a thickening tank, the three chambers being in sequential unidirectional fluid flow relationship.
14. A separation device according to claim 13, wherein the third chamber includes a circumferential overflow launder for decanting excess overflow liquor from the thickening tank to a discharge pipe.
15. A separation device according to claim 13 or claim 14, including a rake assembly rotatably mounted within the thickening tank.
16. A separation device according to claim 15, wherein the rake assembly includes a plurality of radially extending rake arms each fixedly connected at one end to a central hub.
17. A separation device according to claim 16, wherein a plurality of rake blades is fixedly connected to each arm.
18. A separation device according to claim 17, wherein each rake blade extends axially into the tank such that upon rotation of the rake, the blades sweep through the fluid in the tank.

19. A method for separating liquid suspensions or pulps in a thickener, said method including the steps of:
- providing a thickening tank adapted to facilitate settling;
  - providing a feedwell having an upstream chamber and a downstream chamber,
- 5 disposed such that fluid entering said feedwell overflows from said upstream chamber into said downstream chamber from an outlet thereof and then into said thickening tank, the downstream chamber being at least partially defined by sidewalls diverging toward the outlet;
- directing a liquid suspension or pulp into said upstream chamber;
- 10 allowing said liquid suspension or pulp to overflow from said upstream chamber into said downstream chamber; and
- allowing said liquid suspension or pulp to flow from said downstream chamber into said thickening tank to facilitate separation.
20. A method according to claim 19, including the step of providing a restricted
- 15 outlet from said downstream chamber, thereby partially to restrict the flow of the liquid suspension or pulp from the feedwell.
21. A method according to claim 20, wherein a downwardly divergent deflection surface at least partially defines the restricted outlet.
22. A method according to claim 21, including the step of providing the
- 20 downwardly divergent deflection surface as part of a concentrically nested deflection cone forming a floor of the downstream chamber and defining an annular outlet from the downstream chamber.
23. A method according to any one of claims 19 to 22, wherein an inlet to the
- 25 downstream chamber is located generally centrally above a floor of the upstream chamber and fluid flowing from said upstream chamber overflows into said downstream chamber.
24. A method according to any one of claims 19 to 23, wherein the upstream chamber is generally cylindrical.

25. A method according to any one of claims 19 to 24, wherein the downstream chamber is generally concentrically frusto-conical with sidewalls of the downstream chamber diverging downwardly and outwardly from an inlet thereto.
26. A method according to any one of claims 19 to 25, wherein said sequential fluid flow is gravity-driven. 5
27. A method according to any one of claims 19 to 26, further including the step of providing said upstream and downstream chambers with a common sidewall partially defining the restricted outlet of the downstream chamber.
28. A method according to claim 27, wherein said common sidewall is substantially frusto-conical. 10
29. A method according to any one of claims 19 to 28, including the step of mixing flocculant into the liquid suspension or pulp in the upstream chamber.
30. A feedwell for a separation device, substantially as herein described with reference to any one of the embodiments of the invention illustrated in the accompanying drawings and/or examples. 15
31. A separation device, substantially as herein described with reference to any one of the embodiments of the invention illustrated in the accompanying drawings and/or examples.
32. A method for separating liquid suspensions or pulps in a thickener, substantially as herein described with reference to any one of the embodiments of the invention illustrated in the accompanying drawings and/or examples. 20

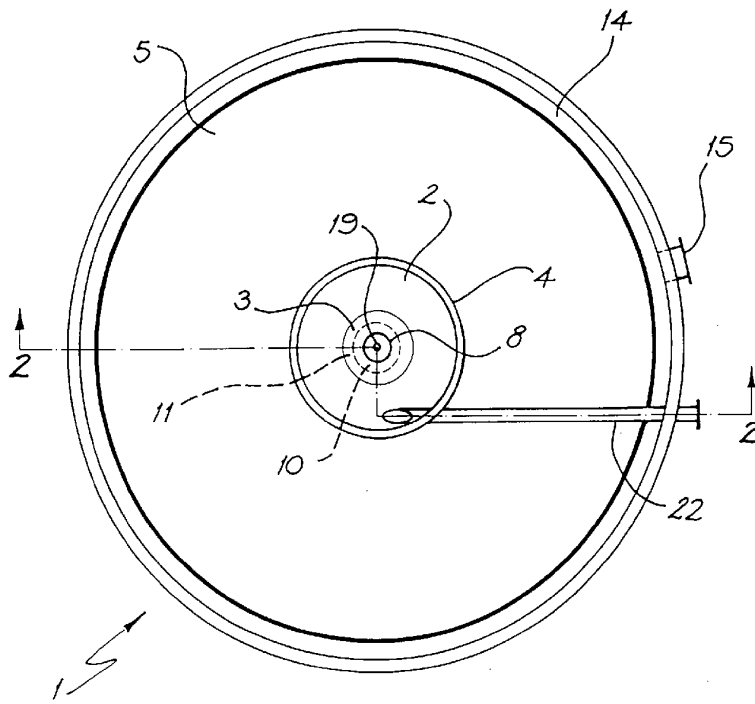

FIG. 1

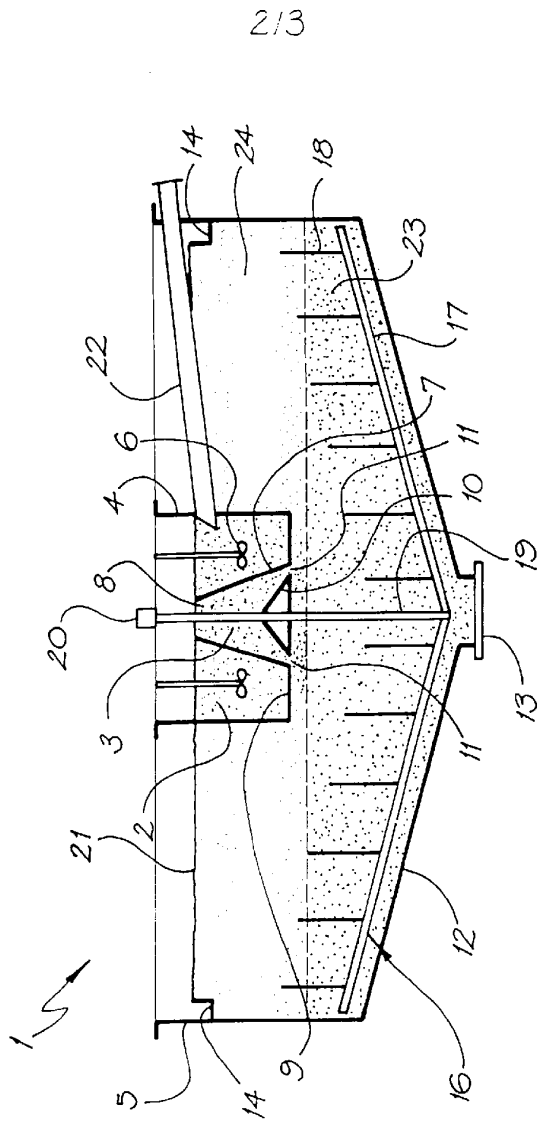

FIG. 2



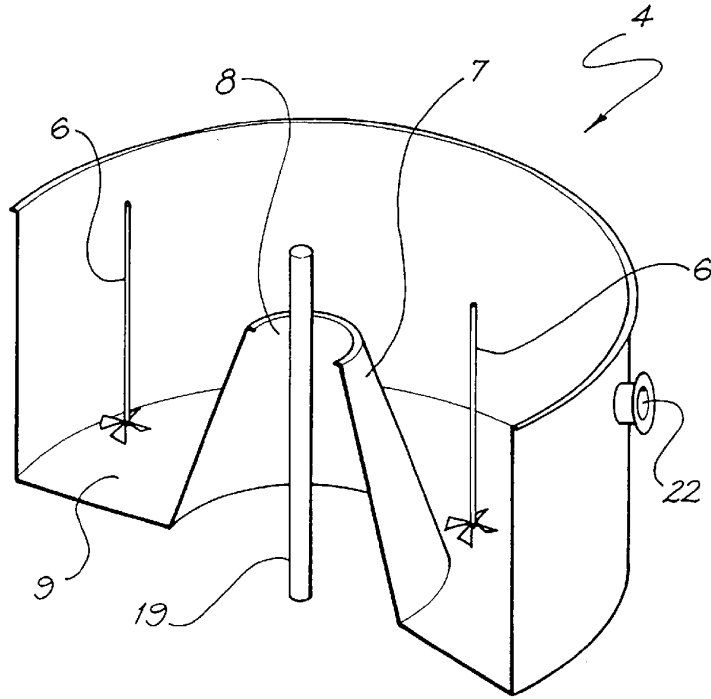

FIG. 3