



(12) **DEMANDE DE BREVET CANADIEN
CANADIAN PATENT APPLICATION**

(13) **A1**

(86) Date de dépôt PCT/PCT Filing Date: 2021/04/30
 (87) Date publication PCT/PCT Publication Date: 2021/11/04
 (85) Entrée phase nationale/National Entry: 2022/10/28
 (86) N° demande PCT/PCT Application No.: US 2021/030287
 (87) N° publication PCT/PCT Publication No.: 2021/222823
 (30) Priorité/Priority: 2020/04/30 (US16/864,124)

(51) Cl.Int./Int.Cl. *C10G 2/00* (2006.01),
C10G 47/00 (2006.01), *C10J 3/46* (2006.01)
 (71) Demandeur/Applicant:
FULCRUM BIOENERGY, INC., US
 (72) Inventeurs/Inventors:
TIVERIOS, PETER G., US;
MACIAS, JAMES E., US;
LUCAS, STEPHEN H., US;
RICH, LEWIS L., US;
THOMSON, GREGOR A., US
 (74) Agent: RIDOUT & MAYBEE LLP

(54) Titre : SYSTEMES DE TRAITEMENT DE CHARGE D'ALIMENTATION ET PROCEDES DE PRODUCTION DE LIQUIDES DE FISCHER-TROPSCH ET DE COMBUSTIBLES DE TRANSPORT
 (54) Title: FEEDSTOCK PROCESSING SYSTEMS AND METHODS FOR PRODUCING FISCHER-TROPSCH LIQUIDS AND TRANSPORTATION FUELS

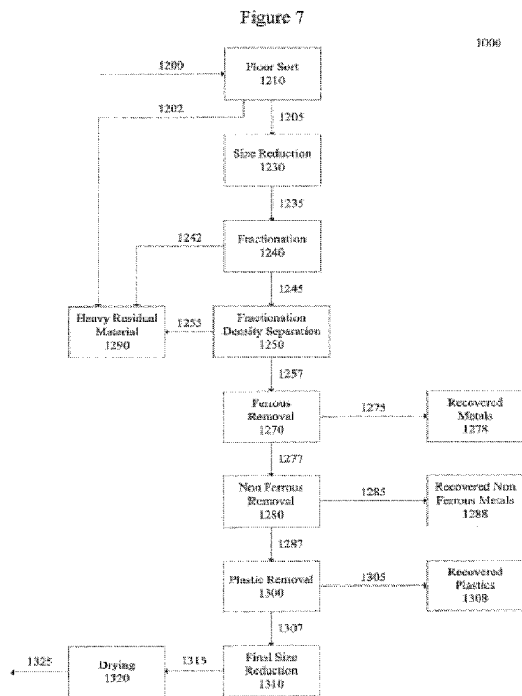

(57) **Abrégé/Abstract:**

A method for processing feedstock is described, characterized in that incoming feedstock is processed to selectively recover biogenic carbon material from the incoming feedstock. In some embodiments the incoming feedstock is comprised of mixed solid waste, such as municipal solid waste (MSW). In other embodiments the incoming feedstock is comprised of woody biomass. In some instances, the incoming feedstock is processed to selectively recover biogenic carbon material from the incoming feedstock to produce a processed feedstock having biogenic carbon content of 50% and greater suitable for conversion into biogenic carbon Fischer Tropsch liquids. The high biogenic carbon Fischer Tropsch liquids may be upgraded to biogenic carbon liquid fuels. Alternatively, the incoming feedstock is processed to selectively recover plastic material from the incoming feedstock to produce a processed feedstock having biogenic carbon content of 50% or less.

Date Submitted: 2022/10/28

CA App. No.: 3177225

Abstract:

A method for processing feedstock is described, characterized in that incoming feedstock is processed to selectively recover biogenic carbon material from the incoming feedstock. In some embodiments the incoming feedstock is comprised of mixed solid waste, such as municipal solid waste (MSW). In other embodiments the incoming feedstock is comprised of woody biomass. In some instances, the incoming feedstock is processed to selectively recover biogenic carbon material from the incoming feedstock to produce a processed feedstock having biogenic carbon content of 50% and greater suitable for conversion into biogenic carbon Fischer Tropsch liquids. The high biogenic carbon Fischer Tropsch liquids may be upgraded to biogenic carbon liquid fuels. Alternatively, the incoming feedstock is processed to selectively recover plastic material from the incoming feedstock to produce a processed feedstock having biogenic carbon content of 50% or less.

**FEEDSTOCK PROCESSING SYSTEMS AND METHODS FOR PRODUCING
FISCHER-TROPSCH LIQUIDS AND TRANSPORTATION FUELS**

CROSS-REFERENCE TO RELATED APPLICATION

[0001] This application claims benefit of priority to U.S. Patent Application No. 16/864,124 filed on April 30, 2020, the entire disclosure of which is hereby incorporated by reference herein.

[0002] The application is further related to the following U.S. patent applications: United States Patent Application No. 13/023,497, filed February 8, 2011, entitled “Processes For Recovering Waste Heat From Gasification Systems For Converting Municipal Solid Waste Into Ethanol,” which issued on December 10, 2013 as U.S. Patent No. 8,604,088 B2, and United States Patent Application No. 13/023,510, filed February 8, 2011, entitled “Gas Recycle Loops in Process For Converting Municipal Solid Waste Into Ethanol,” which issued on December 10, 2013 as U.S. Patent No. 8,604,089 B2. These applications are incorporated by reference hereinto.

TECHNICAL FIELD

[0003] The subject matter relates generally to processes, systems, and facilities for processing feedstocks and converting processed feedstocks including organic or carbonaceous materials such as without limitation municipal solid wastes (MSW) into fuel.

BACKGROUND

[0004] Municipal solid waste (MSW) includes all solid materials disposed by municipalities. While some of this waste is recycled, the majority is typically dumped in landfills, where it decomposes over a period of decades or even centuries. It has been

recognized that municipal solid waste contains organic materials that have energy content. If MSW is left untreated in landfills, the energy content can be drained slowly from the landfill by bacterial processes, which not only dissipate the concentrated energy but, also, produce methane, a strong greenhouse gas. Some landfills have sought to collect methane, which may be used for fuel; however, the conversion to methane takes place on long time scales, wastes much of the internal energy of the MSW, and is rather ineffective in recovering much of the available energy content of the MSW.

[0005] The earliest and most common method of recovering energy from MSW is incineration. Incineration includes the combustion of MSW or refuse-derived fuel (RDF) to produce heat, which typically powers a turbine to produce electricity. Byproducts of incineration include fly ash, bottom ash, and flue gases containing dangerous pollutants including sulfur compounds, CO₂, which is a green-house gas, acid gases as well as metals, metal compounds and particulates. Fly ash and bottom ash are typically discarded in landfills. Some harmful flue gases and particulates can be scrubbed from the incineration flue stream prior to discharge into the atmosphere.

[0006] Another method of recovering energy from MSW is pyrolysis, which involves heating the organic portions of the MSW, so that thermally unstable compounds are chemically decomposed into other compounds. Those compounds mix with other volatile components to form a pyrolysis gas that typically includes tars, alkenes, aromatic hydrocarbons, sulfur compounds, steam, and carbon dioxide. The solid residue from pyrolysis process includes coke (residual carbon), which can then be burned or used as a gasification feedstock.

[0007] A related method for recovering energy from MSW is gasification. Gasification involves converting at least a fraction of the MSW into a synthesis gas (“syngas”) composed mainly of carbon monoxide carbon dioxide, and hydrogen. Gasification technology has

existed for some centuries. In the nineteenth century, for instance, coal and peat were often gasified into “town gas” that provided a flammable mix of carbon monoxide (CO), methane (CH₄) and hydrogen (H₂) that was used for cooking, heating and lighting. During World Wars I and II, biomass and coal gasifiers were used to produce CO and H₂ to meet transportation needs. Sometimes, some of the syngas was converted directly in to liquid transportation fuels using the Fisher-Tropsch process. With the discovery of vast quantities of domestic oil and natural gas following World War II, coal and biomass gasification were no longer cost-competitive and all but disappeared.

[0008] Gasification has been applied directly to the MSW but, in other cases, the MSW is first pyrolyzed, and then subjected to a secondary gasification process. Gasification of MSW generally includes a mechanical processing step that removes recyclables and other materials that have low or no energy content. Then, the processed feedstock is heated in a gasifier in the presence of a gasification agent (including at least some oxygen and possibly steam). Gasifiers may have a number of configurations. For example, fixed-bed gasifiers place the feedstock in a fixed bed, and then contact it with a stream of a gasification agent in either a counter-current (“up draft”) or co-current (“down draft”) manner. Gasifiers may also use fluidized bed reactors.

[0009] Another method of gasifying MSW is treatment in the presence of oxygen with a high-temperature plasma. Such systems may convert the MSW to syngas, leaving vitrified wastes and metals as byproduct.

[0010] To create hydrocarbons as synthetic fuels, a known method for converting syngas into synthetic fuels is the catalytic Fischer-Tropsch (F-T) process. This process produces a mixture of hydrocarbons which could be further refined to produce liquid transportation fuels.

[0011] With numerous detrimental effects of greenhouse gases being increasingly documented, there is a clear need to reduce energy production from fossil fuels, particularly from petroleum and coal-derived fuel sources. To encourage the reduction of fossil fuel usage, governments are promoting the usage of fuels derived from renewable organic sources rather than fossil-based sources.

[0012] The Environmental Protection Agency (EPA) in the United States has mandated a Renewable Fuel Standard (“RFS”) under which cellulosic-based fuels generate Cellulosic RINs (renewable identification numbers) which are a form of compliance credits for Obligated Parties (e.g., refineries). Under the RFS, the Obligated Parties are required to blend an increasing amount of cellulosic fuel into fossil-derived fuels.

[0013] To determine the biogenic percentage content of fuels, the EPA requires tests that use radiocarbon dating methods. More particularly, current the USEPA regulations, at Section 8.1426(f)(9), require parties to use Method B or Method C of ASTM D 6866 to perform radiocarbon dating to determine the renewable fraction of the fuel.

BRIEF SUMMARY OF THE INVENTION

[0014] The present disclosure generally relates to processes and methods for converting organic materials, such as are contained in MSW, into fuels. More particularly, the present disclosure relates to processes for producing high biogenic concentration Fischer-Tropsch liquids and the respective upgraded fuel products derived from the organic fraction of municipal solid wastes (MSW) feedstocks that contain relatively high concentrations of biogenic carbon (derived from plants) and a relatively low concentration of non-biogenic carbon (derived from fossil sources) along with other non-carbonaceous materials. In practice, the relatively high concentration of biogenic carbon is up to about 80% biogenic carbon. Particularly noteworthy is that the high biogenic concentration Fischer-Tropsch

liquids contain the same relatively high concentration of biogenic carbon as the feedstock derived from MSW.

[0015] In another aspect, embodiments of the present disclosure relate to feedstock processing systems and methods for producing a segregated or processed feedstock. In some embodiments, the feedstock processing system is configured to produce processed feedstock that contains a higher concentration of biogenic carbon materials than non-biogenic carbon materials. For example, in some embodiments, the processed feedstock has a biogenic carbon content in the range of 50% to 100% by weight, or 51% to 95% by weight. In other embodiments, the feedstock processing system is configured to process multiple feedstock streams such as but not limited to, MSW feedstock streams, woody biomass or other biomass feedstock streams, plastic feedstock streams, and mixtures of any of the aforementioned streams. In another embodiment where plastics are included in the feedstock steam, the processed feedstock may have a biogenic carbon content of 50% or less by weight.

[0016] In another embodiment, the present disclosure provides a method for processing feedstock, characterized in that incoming feedstock is processed to selectively recover biogenic carbon material from the incoming feedstock. In some embodiments the incoming feedstock is comprised of mixed solid waste. In other embodiments the incoming feedstock is comprised of woody biomass. In some embodiments, the mixed solid waste is municipal solid waste (MSW). In some instances, the incoming feedstock is processed to selectively recover biogenic carbon material from the incoming feedstock to produce a processed feedstock having biogenic carbon content of 50% and greater suitable for conversion into biogenic carbon Fischer Tropsch liquids. The high biogenic carbon Fischer Tropsch liquids may be upgraded to biogenic carbon liquid fuels. In alternative embodiments, the incoming feedstock is processed to selectively recover plastic material from the incoming feedstock to produce a processed feedstock having biogenic carbon content of 50% or less.

BRIEF DESCRIPTION OF THE DRAWINGS

[0017] The accompanying drawings, which are incorporated into this specification, illustrate one or more exemplary embodiments of the inventions disclosed herein and, together with the detailed description, serve to explain the principles and exemplary implementations of these inventions. One of skill in the art will understand that the drawings are illustrative only, and that what is depicted therein may be adapted, based on this disclosure, in view of the common knowledge within this field.

[0018] Various embodiments, including additions and modifications to the illustrated embodiment, of the present inventions are described herein in the context of converting feedstock derived from MSW waste into fuels.

[0019] In the Drawings:

[0020] **FIG. 1** shows one embodiment of an overall system for producing high biogenic concentration Fischer-Tropsch liquids derived from municipal solid wastes (MSW) feedstock; that contains a relatively high concentration of biogenic carbon and a relatively low concentration of non-biogenic carbons along with other non-carbonaceous materials;

[0021] **FIG. 2** shows an example of one embodiment of a gasification island;

[0022] **FIG. 3** shows an example of one embodiment of a syngas conditioning system;

[0023] **FIG. 4A** shows an example of one embodiment of a CO₂/H₂S removal system;

[0024] **FIG. 4B** shows an example of another embodiment of a CO₂/H₂S removal system;

[0025] **FIG. 5** shows an example of one embodiment of a system for generating F-T liquids;

[0026] **FIG. 6** shows an example of one embodiment of a system for producing refined F-T liquids from the system of **FIG. 5**;

[0027] FIG. 7 is a schematic diagram illustrating one embodiment of a feedstock processing system and method;

[0028] FIG. 8 is a schematic diagram showing another embodiment of a feedstock processing system and method;

[0029] FIG. 9 is a schematic diagram depicting another exemplary embodiment of a feedstock processing system and method;

[0030] FIG. 10 is a schematic diagram showing another exemplary embodiment of a feedstock processing system and method;

[0031] FIG. 11 is a schematic diagram illustrating another embodiment of a feedstock processing system and method;

[0032] FIG. 12 is a schematic diagram showing another embodiment of a feedstock processing system and method.

DETAILED DESCRIPTION

[0033] Those of ordinary skill in the art will understand that the following detailed description is illustrative only and is not intended to be in any way limiting. Other embodiments of the present inventions will readily suggest themselves to such skilled persons having the benefit of this disclosure, in light of what is known in the relevant arts, the provision and operation of information systems for such use, and other related areas. Reference will now be made in detail to exemplary implementations of the present inventions as illustrated in the accompanying drawings.

[0034] In the interest of clarity, not all of the routine features of the exemplary implementations described herein are shown and described. It will of course, be appreciated that in the development of any such actual implementation, numerous implementation-specific decisions must be made in order to achieve the specific goals of the developer, such

as compliance with regulatory, safety, social, environmental, health, and business-related constraints, and that these specific goals will vary from one implementation to another and from one developer to another. Moreover, it will be appreciated that such a developmental effort might be complex and time-consuming but would nevertheless be a routine undertaking of engineering for those of ordinary skill in the art having the benefit of this disclosure.

[0035] Throughout the present disclosure, relevant terms are to be understood consistently with their typical meanings established in the relevant art. However, without limiting the scope of the present disclosure, further clarifications and descriptions are provided for relevant terms and concepts as set forth below:

[0036] The term *municipal solid waste* (MSW) as used herein has the same meaning as the term is understood by one of skill in the art. An example of MSW is the solid waste that is obtained from the collection of commercial and household trash. In its raw form, MSW need not be entirely solid, as it may contain entrained or absorbed liquids, or liquids in containers or other enclosed spaces. One of skill in the art will understand that MSW will have a broad range of compositions, and that the source of MSW need not necessarily be from a municipality. For purposes of this disclosure, other organic waste materials and various biomass materials such as vegetative matter, may be equivalent to MSW.

[0037] The term *stream* as used herein means any fluid or solid moving or en route, directly or indirectly, from one location to another. A stream is still a stream even if it is temporarily stationary.

[0038] Reference to a *portion* of a stream or material refers to any portion of the stream or material, including the stream or material in its entirety. A portion of a stream or material may be mixed with other compositions of matter and the mixture will be considered to comprise the portion of the original stream or material.

[0039] The term *in fluid communication with* as used herein includes without limitation both direct and indirect fluid communication, such as, for example, through an intermediate process unit.

[0040] The term *unit* as used herein means part of a system, and may for example comprise a unit operation, a system or group of unit operations, a plant, etc.

[0041] The term *syngas* (synthesis gas) as used herein has the same meaning as the term is used by one of skill in the art. For example, syngas may comprise a combination of carbon monoxide, hydrogen, carbon dioxide and possibly other components such as, without limitation, water vapor, sulfur- or nitrogen-containing compounds, methane and other alkanes, hydrocarbons, acid gases, halogens and particulates.

[0042] The term *separator* as used herein refers to any process unit known in the art for performing a separation process and, depending upon context, can include distillation columns, membrane separation systems, ion exchange adsorption systems, thermal adsorption, pressure swing adsorption, molecular sieves, flash drums, absorption or adsorption columns, wet scrubbers, venturi scrubbers, centrifuges, chromatographs, or crystallizers. Separators may separate vapors from liquids, liquids from liquids, vapors from liquids from solids, solids from solids, or fluids from solids.

[0043] The term *heat exchanger* as used herein includes without limitation any heat exchanger or heat exchange device known in the art, and more broadly, any device which raises the enthalpy or internal energy of a first composition of matter, decreases the enthalpy or internal energy of a second composition of matter, and transfers heat from the second composition of matter to the first composition of matter. Various heat exchange means are disclosed herein, all of which are encompassed within this term. The term also includes combinations or series of multiple heat exchange means. It includes, without limitation, shell and tube heat exchangers, air or “fin-fan” coolers, refrigeration units, chillers, cooling towers,

steam generators, boilers, plate heat exchangers, adiabatic wheel heat exchangers, plate fin heat exchangers, fluid heat exchangers, waste heat recovery units of any kind, or phase change heat exchangers of any kind. They may operate in a countercurrent, parallel, crosscurrent configuration, or any other flow configuration, and may involve separation of two fluids or direct contact between two fluids, or the use of an intermediate fluid (such as water, hot oil, molten salt, etc.) to transfer heat from one fluid to another.

[0044] The term *compressor* as used herein includes anything that is understood as a compressor in the normal sense of that term. In general, however, the term includes any device that raises a fluid from a first pressure to a second, higher pressure, either adiabatically or non-adiabatically. It may include any kind of compressor or pump, including without limitation, centrifugal or axial, or positive displacement (such as reciprocating, diaphragm, or rotary gear). The term may also include one or more stages of a multi-stage compressor. The term *compressor* used in the singular may also refer to multiple compressors arranged in series and/or parallel.

[0045] In **Fig.1**, the numeral 11 designates an overall system for producing high biogenic concentration Fischer-Tropsch liquids derived from municipal solid wastes (MSW) feedstock that contains a relatively high concentration of biogenic carbon and a relatively low concentration of non-biogenic carbons along with other non-carbonaceous materials.

[0046] At the head of the system 11, a MSW feedstock producing facility, generally designated by the numeral 13, is provided for removing non-biogenic derived carbon materials and non-carbonaceous materials from MSW to produce a segregated feedstock that contains a relatively high concentration of biogenic carbon and a relatively low concentration of non-biogenic carbon along with other non-carbonaceous materials found in MSW.

[0047] In the preferred embodiment, the Feedstock Processing Facility 13 will process inbound MSW and separate materials into the following categories:

- Feedstock Material, sorted from MSW stream to be used for conversion into fuel;
- Recoverable Material, including but not limited to ferrous and nonferrous metals, cardboard, plastics, paper, and other recyclable materials that can be sorted and shipped to the commodities markets; and
- Residual Material, which is the remainder of the material not recycled or used as feedstock, which can be sent to landfill.

[0048] By recovering plastics such as High Density Polyethylene (HDPE) and Polyethylene Terephthalate (PET) among others, the percentage of non-biogenic carbon in the feedstock is reduced as the percentage of fossil based plastics is reduced. Thus, the feedstock processing facility functions to provide a highly biogenic feedstock material that can be gasified into syngas. For the reasons explained above, the biogenic percentage content of the feedstock has a significant impact on the economic value of the cellulosic fuel.

[0049] In the feedstock processing unit 13, the waste material may be sized, separated, and processed to remove materials that are not useful in the process, or which might reduce its efficiency. For example, the system removes metals, inorganic materials, and wet materials such as food waste or agricultural products. Such materials may, for example, be recycled or sent to a landfill. Some of the food waste and agricultural materials which are high in biogenic content could be dried and added back to the feed stream along with other materials.

[0050] As indicated in the drawing, the Feedstock Processing Facility 13 can be physically separate facility from the other portions of the system shown in Fig. 1. As an example, the Feedstock Processing Facility 13 can be as described in co-pending United States patent application Serial No: 14/138,635 for Product Recycle Loops in Process for Converting Municipal Solid Waste into Ethanol, the disclosure of which is incorporated herein by reference. In another example, the Feedstock Processing Facility 13 can be as described

below and shown in **Figs. 7 – 12** herein. The Feedstock Processing Facility can be co-located or separate from the other portions of the system shown in **Fig. 1**.

[0051] Although the feedstock may vary greatly in composition, in one exemplary embodiment: incoming material (reference number 1200 in Figures 7 - 12), which is also referred to as raw or initial material or feedstock, is a diverse and heterogeneous mix of MSW. The composition of the MSW typically ranges widely. For purposes of this description, unless otherwise stated, all percentage (%) values described herein are weight percent (wt. %). In some embodiments for example and without limitation, plastic content can range from 10% to 30%, mixed paper content can range from 10% to 40%, wood content can range from 5% to 20%, textiles and fabrics can range from 1% to 15%, food and yard waste can range from 5% to 20%, ferrous metal can range from 1% to 10%, non-ferrous metal can range from 0.1% to 1.5%, inert material greater than 2 inches in size can range from 1% to 15%, and residual material less than 2 inches in size can range from 5% to 40%. The moisture content of the incoming MSW can range from 5% to 50%.

[0052] One example of nominal elemental composition of the material remaining after the feedstock is recycled and sorted are listed in Table 1 below.

Table 1. Example Ultimate Chemical Composition of Feedstock

| Feedstock Constituent | Approx. Weight (Percent) |
|-----------------------|--------------------------|
| C | 45.4 |
| H | 5.7 |
| O | 33.8 |
| N | 0.7 |
| S | 0.11 |
| Cl | 0.09 |
| Ash | 4.21 |
| Metal | 1.4 |
| H ₂ O | 8.6 |

[0053] The residual materials preferably excluded by the processing, storage, and handling process may include, for instance, metals, rocks, dirt, glass, concrete, and PVC. Preferably, under normal conditions, the reject rate will run between about 10% and about 55% of the total feed rate to the material processing unit. Preferably, they will be individually separated from the feedstock, deposited in a container, and transported to a landfill or composting operation, or sent for recycling or disposal off-site in accordance with applicable governmental regulations. Figs. 7 – 12 illustrate additional embodiments of a feedstock processing system for producing a processed or segregated feedstock that contains a selective concentration of biogenic carbon and non-biogenic carbon, from a variety of raw or initial or incoming feedstocks. **Figs. 7 – 12** are described in detail later below.

[0054] An important point is that a bio-refinery, generally designated by the numeral 17, is fed with a stream 15 containing relatively high concentration of biogenic carbon and the relatively low concentration of non-biogenic carbons along with other non-carbonaceous materials from the municipal solid wastes. In practice, the relatively high concentration of biogenic carbon is up to about 80% biogenic carbon.

[0055] The remainder of the system depicted in **Fig. 1** is the bio-refinery 17 for converting the stream 15 of processed feedstock into a stream 19 of Fischer-Tropsch liquids.

Particularly noteworthy is that the high biogenic concentration Fischer-Tropsch liquids contain the same relatively high concentration of biogenic carbon as the input stream 15. In other words, percentage-wise, no non-biogenic carbon is added to the Fischer-Tropsch liquids in the production system and, indeed, some may be eliminated.

[0056] In the illustrated embodiment, the bio-refinery 17 includes a gasification system, generally designated by the numeral 21 and sometimes referred to herein as the Gasification Island (GI), for converting feedstock derived from MSW into syngas and further processing that syngas through a hydrocarbon reformer (HR), as will be described below, to generate a high biogenic content syngas. It should be noted that the gasification system 21 receives streams 231 and 235 that carry recycled hydrocarbon products and intermediate products, respectively, to the HR. Also, the GI 21 receives a stream 27 that carries recycled CO₂ to its stage 1 and stage 2, both of which will be described in detail below. Also, as will be explained further below, the recycled CO₂ is used for moderating the water-gas-shift reaction within the steam reformer in the GI 21 and as a purge gas for instruments, instrument systems and MSW feeder systems. Further, the GI 21 receives stream 273 of oxygen and a stream 25 of F-T tail gas.

[0057] In the gasification island 21, generally speaking, the biogenic carbon is converted into biogenic syngas by a combination of steam reforming, sub-stoichiometric carbon oxidation and hydrocarbon reformation. The syngas product, including CO, H₂ and CO₂, is carried by stream 29 in the illustrated embodiment. The gasification reactions occurring in the GI 21 will be further described below.

[0058] The syngas stream 29 is processed in a syngas conditioning system 41, as will be described in more detail below, to provide a syngas feed stream 31 to an F-T reactor system

33. It should be noted that the syngas conditioning system 41 provides the CO₂ recycle stream 27 for recycling CO₂ back to the GI 21.

[0059] The output from the F-T reactor system 33 comprises F-T fluids, including a Medium Fischer Tropsch Liquid (MFTL) stream 520 and a Heavy Fischer Tropsch liquid (HFTL) stream 540, both of which are F-T hydrocarbons. Any unreacted syngas can be recycled in the F-T reactor 33 as will be described below. Further, the output of the F-T reactor system 33 includes the afore-mentioned stream 25 of F-T tail gas.

[0060] The bio-refinery includes a hydrogen recovery system to remove hydrogen that is needed for upgrading from the conditioned syngas. A portion of the conditioned syngas flows through a combination membrane/PSA unit to yield a high purity hydrogen stream for the upgrading unit. The recovered hydrogen (permeate) from the membrane is fed to a PSA unit and the retentate is combined with bypass syngas and fed forward to the FT reactor. The recovered hydrogen is fed to the PSA unit where a relatively pure hydrogen stream is produced (>99.5% H₂) and the PSA reject stream is routed to the suction of the syngas compressor for recovery of the reject syngas.

[0061] The bio-refinery 17 in **Fig. 1** further includes an upgrading system 54 for receiving the F-T fluids from the F-T system 33. In the illustrated embodiment, both the Heavy Fischer Tropsch liquid (HFTL) stream 540 and the Medium Fischer Tropsch Liquid (MFTL) stream 520 are fed to the upgrading system 54. The F-T liquids output liquid from the upgrading system 54 is carried by the stream 58 in the illustrated embodiment. In practice, the F-T liquids can include naphtha, diesel, Synthetic Paraffinic Kerosene (SPK), heavier alkanes along with iso-alkanes, oxygenates, and olefins or combinations of all of these components. Other outputs from the upgrading system 54 are the aforementioned stream 231 of naphtha and the stream 233 of off gas.

[0062] The gasification island system 21, as shown in detail in **Fig. 2**, implements a 3-stage gasification process. In the preferred embodiment, the 3-stage gasification process includes:

- a. Stage 1 – steam reforming;
- b. Stage 2 – sub-stoichiometric carbon oxidation to gasify unreacted carbon after steam reforming; and
- c. Stage 3 – hydrocarbon reforming.

[0063] In the illustrated embodiment, the gasification unit, generally designated by the numeral 211, includes stage 1 and 2 units, generally designated by the numerals 251 and 271, respectively. It can be understood that unit 251 is a steam reformer wherein gasification is accomplished. Further it can be understood that unit 271 is a carbon oxidation system wherein unreacted carbon from the stage 1 gasification is converted into syngas sub-stoichiometrically. Also in the gasification island 21, hydrocarbon reforming is provided in a third stage by a hydrocarbon reforming system generally designated by the numeral 215.

[0064] Steam reformer 251 selectively receives the stream 15 of processed feedstock and produces a stream 219 of syngas. Also, the gasification unit 211 receives streams 27 of recycled CO₂. In the gasification unit 211, the recovered high biogenic CO₂ in stream 27 can be used to assist in fluidizing the bed materials, moderating the water-gas-shift reaction and purging instruments in the steam reformer 251, in the sub-stoichiometric carbon oxidation unit 271 and in the hydrocarbon reformer 215. Also, the recovered high biogenic CO₂ in stream 27 can be added to stream 15 of processed feedstock as shown.

[0065] As mentioned above, the gasification unit 211 in the embodiment of Fig. 2 includes the steam reformer 251 and the sub-stoichiometric carbon oxidation unit 271. It is the steam reformer 251 that initially receives the steam 15 of processed feedstock. Also, it is the steam reformer 251 that initially receives the steam 273 of oxygen. Preferably, the steam reformer

251 includes an indirect heat source 253. The output streams from the steam reformer 251 include a stream 254 of syngas and a stream 256 of solids. The syngas stream 254 is carried to the hydrocarbon reforming unit 215 with the stream 219. The solids stream 256, primarily comprised of ash and fine char, is carried to the sub-stoichiometric carbon oxidation unit 271.

[0066] In the preferred embodiment, the steam reformer 251 is a fluidized bed system that utilizes superheated steam, CO₂, and O₂ as the bed-fluidizing medium. In another embodiment only steam and O₂ are used as a bed-fluidizing medium. Preferably, externally-fired indirect heaters 253 maintain the reformer bed temperature and provide much of the energy to support the endothermic reactions required in the gasification process. The process gas stream can exit the steam reformer 251 through a series of cyclones. Preferably, an internal cyclone separates and returns the majority of any entrained bed media to the reformer fluidized bed while a second external cyclone collects unreacted char for further conversion to syngas in the sub-stoichiometric carbon oxidation unit 271. Preferably, flue gas from the steam reformer's indirect heaters is used in a fire tube boiler to generate steam for plant use.

[0067] The illustrated hydrocarbon reformer unit 215 receives the syngas stream 219 and produces the afore-mentioned primary stream 29 of syngas containing CO, H₂ and CO₂ along with trace constituents. Further, the hydrocarbon reformer unit 215 receives stream 273 of oxygen and stream 25 of F-T tail gas. Finally, the hydrocarbon reformer unit 215 receives the aforementioned streams 231 of naphtha and 233 of off gas.

[0068] The hydrocarbon reformer unit 215 operates to recover the biogenic carbon by thermally dissociating hydrocarbons at temperatures greater than 2200 degrees F. Heat for the hydrocarbon reformer is provided by oxidation of carbon monoxide and hydrogen. It may be noted that these reactions are exothermic.

[0069] The hydrocarbon reformer unit 215, in the embodiment of Fig. 2, includes a syngas cooling section 225. The syngas cooling section can comprise, for example, a radiant slagging cooler or a recycle syngas slagging quencher.

[0070] In preferred practice, the hydrocarbon reforming unit 215 is a refractory-lined vessel with oxygen gas burner/mixer which operates in the range of 1800°F to 3000°F to assure all hydrocarbon compounds in the gas stream, including tars are converted to syngas, sulfur compounds are converted to H₂S, and the water gas shift reactions approach equilibrium. In the hydrocarbon reforming unit 215, the F-T tail gas purged from the F-T reaction loop, the purification system off gas, and stream 231 of vaporized naphtha are converted back to CO and H₂.

[0071] The sub-stoichiometric carbon oxidation unit 271, in addition to receiving the solids stream 256, receives the stream 27 of recycled CO₂ stream and a stream 273 of oxygen. Heating in the carbon sub-stoichiometric oxidation unit 271 is provided by sub-stoichiometric oxidation of the unreacted carbon. A stream 275 of low pressure steam is superheated in the sub-stoichiometric carbon oxidation unit and used as fluidization steam for both stage 1 and stage 2 gasification. The output of the sub-stoichiometric carbon oxidation unit 271 is syngas stream 277 which, in the illustrated embodiment, joins with the syngas stream 254 from steam reformer 251 to form syngas stream 219 which is fed to the hydrocarbon reformer unit 215.

[0072] In the preferred embodiment, the sub-stoichiometric carbon oxidation unit 271 utilizes a fluidized bed in which oxygen is added with the fluidization steam and CO₂ to further convert fine char to syngas. The gasses generated in and passing through the sub-stoichiometric carbon oxidation unit 271 pass through an external cyclone and re-enter the main syngas stream 219. Preferably, the ash removed in the cyclone is cooled and transported to a collection silo for offsite disposal. Heat exchangers, submerged in the fluid

bed of the sub-stoichiometric carbon oxidation unit 271 remove some heat by superheating low-pressure steam to 1100°F for use in the fluidization bed steam reformer 251 and the fluidization bed of the unit 271 itself.

[0073] In operation of the system of **Fig. 2**, within the fluidized bed of the steam reformer 251, externally fired heaters rapidly heat the circulating bed media and the feedstock entering the vessel. Almost immediately, the feedstock undergoes drying and pyrolysis, thereby creating gaseous and solid (char) products. The gaseous pyrolysis products undergo water-gas shift reactions and together with simultaneous steam reforming of the solid char material, produce a syngas primarily made up of H₂, CO, CO₂, and some hydrocarbons. Most remaining char reacts with superheated steam and oxygen to produce syngas. Char that escapes the steam reformer is separated via a cyclone and dropped into the sub-stoichiometric carbon oxidation unit for additional gasification and conversion. The steam reformer and the sub-stoichiometric carbon oxidation unit utilize internal and external cyclones to separate and retain bed media that becomes entrained in the process gas stream. From the steam reformer 251 and the sub-stoichiometric carbon oxidation unit 271, the syngas flows via stream 219 to the hydrocarbon reformer unit 215 to convert any remaining char, hydrocarbons, and tars into syngas.

[0074] As mentioned above, the output of the hydrocarbon reformer unit 215 is the syngas stream 29 which is fed to the syngas conditioning system 41 which will now be described in conjunction with **Fig. 3**.

[0075] As shown in **Fig. 3**, the exemplary syngas conditioning system, which has been generally designated by the numeral 41, receives the primary syngas stream 29 and conditions that stream to produce the gaseous feed stream 31 to F-T reactors. In the illustrated embodiment, the syngas conditioning system 41 includes, sequentially in fluid flow communication, a Syngas Heat Recovery Steam Generator (HRSG) unit 411 for waste heat

recovery, a syngas scrubber unit 421, a syngas compressor 431, a primary guard bed 436, a water gas shift reactor 441, ammonia removal unit 446, secondary guard beds 451, and a CO₂/H₂S removal system 461. One output of the CO₂/H₂S removal system 461, in the illustrated embodiment, is a syngas feed stream 470. Another output of the CO₂/H₂S removal system 461 is the stream 27 of recycled CO₂.

[0076] As can be seen from the drawings, steam is generated from several sources inside the process. A HRSG recovers steam from the flue gas generated in the indirect fired heater unit 253 in the steam reformer unit 251. Steam is also generated in the HRSG unit 411 that recovers heat from the syngas stream 29 leaving the gasification island and steam is generated in the power boiler. The steam from all three sources are combined and superheated to provide the medium pressure steam used as the motive fluid in either syngas compressor (unit 431) steam turbine or a steam turbine power generator (Fig. 1). The combined medium pressure steam can have a biogenic content equal to the MSW feed depending on the quantity of natural gas used in firing the external heaters. In the preferred embodiment a portion of the generated syngas is fed to a gas turbine / steam turbine (combined cycle power plant) to generate a high biogenic content power that is used to supply the electrical demand of the plant. In another embodiment, all of the syngas is used to generate steam for biogenic power and to drive the syngas compressor unit 431 with a steam turbine drive.

[0077] The syngas scrubber unit 421 is a conventional gas scrubbing device that receives the syngas stream 420 and a stream 424 of caustic or other suitable alkaline solution. The liquids removed from the scrubber unit 421 comprise sour water stream 426 which can be conveyed to a wastewater treatment system. The sour water may contain undesirable contaminants such as, for example, ash particles, acids, mercury, and acidic compounds such as hydrochloric acid (HCl) and hydrogen sulfide (H₂S) that are removed from the syngas.

Thus, it can be appreciated that the syngas scrubber unit 421 is provided to remove contaminants that can potentially damage downstream equipment and affect the F-T synthesis catalyst performance.

[0078] Preferably, the syngas scrubber unit has three primary sections - a venturi scrubber, a packed tower section, and a direct contact cooler section. If a syngas quench cooler is utilized then approximately half of the cleaned syngas leaving the syngas scrubber unit will be circulated back to the hydrocarbon reformer quench cooler via the quench blowers while the remaining half will be compressed in the syngas compressor 431 to meet the requirements of the F-T synthesis process. If a radiant slagging cooler is employed the recycle gas blower will not be required and the flow into the scrubber will equal the flow leaving the gasification island 21. Syngas scrubbing is further described in co-pending United States patent application Serial No: 14/138,635, the disclosure of which has been incorporated herein by reference. The scrubbed syngas is conveyed in stream 428.

[0079] In the illustrated embodiment, a syngas compressor stage 431 comprising one or more conventional compressor stages 433 arranged in series to raise the pressure of a compressor inlet stream comprising at least a portion of the syngas stream to a predefined level, thereby outputting a compressed syngas stream 434. In practice, the final pressure of the syngas stream 434 may range between about 400 psig to about 600 psig to meet the process requirements of the F-T synthesis process. Preferably, the heat of compression is removed with intercoolers after all but the final stage with all condensed water being collected and sent to the waste water treatment plant for recovery. The outlet of the compressor is sent hot to primary guard bed 436 where any COS and HCN is hydrolyzed to H₂S and NH₃ and then to the shift reactor 441.

[0080] In one embodiment, the syngas compressor drive is an extraction/condensing turbine that is driven by superheated high pressure steam with a portion of the steam

extracted at low pressure for process requirements. Also, the F-T recycle compressor (unit 511 in Fig. 5) can be on the syngas compressor shaft and driven by the syngas compressor steam turbine drive. In another embodiment the syngas compressor is driven by an electric motor which is energized from the power generated in a combined cycle power plant using syngas as a fuel to produce high biogenic power.

[0081] As also shown in **Fig. 3**, the water gas shift reactor 441 receives a portion of the pressurized primary syngas stream 440 to shift some of the steam and CO into H₂ and CO₂ via the water gas shift reaction until the required H₂/CO ratio in the outlet stream 450 is met. Subsequently, a side stream 442 of the pressurized primary syngas may bypass the water gas shift reactor 441 and may be recombined with an outlet stream 450 from the water gas shift reactor 441. High pressure steam is generated in the water gas shift unit to remove the shift heat of reaction. The generated steam is fed back into the syngas stream 440 feeding the reactor to provide the hydrogen source for the shift reaction. Any additional steam required can be provided by the plant steam system.

[0082] In the embodiment of **Fig. 3**, the outlet stream 450 of syngas from the water gas shift reactor 441 is provided to a conventional ammonia removal unit 446. In the ammonia removal unit 446, the syngas is cooled until the excess water condenses out with absorbed ammonia. Then, the syngas leaves the condenser 446 as stream 448. The sour water from the condenser 446 can be conveyed to a wastewater treatment system. The stream 448 is conveyed to the inlet of the second guard bed 451 where any volatilized Hg is removed.

[0083] As further shown in **Fig. 3**, the pressurized primary syngas from the second guard beds 451 is conveyed as a stream 460 to the CO₂/H₂S removal system 461. The CO₂/H₂S removal system 461 will be further described in conjunction with Figs. 4A and 4B. One output of the CO₂/H₂S removal system 461 is a stream 464 of sulfur. Another output is a

stream 470 of syngas from which sulfur has been removed. The third output is the CO₂ recycle stream 27.

[0084] In the illustrated embodiment of **Fig. 3**, the syngas feed stream 470 is conveyed to H₂S and final guard arsine beds 471 and, then, to an H₂ recovery unit 481.

[0085] Syngas from the H₂S/Arsine guard beds flows into the hydrogen recovery unit 481. The hydrogen recovery unit 481 extracts a stream 482 of high purity H₂ which is required for the Hydrocracking Upgrading process, as described below. The output of the H₂ recovery unit 481 is the syngas feed stream 31 to the F-T reactor 33. A third output from the hydrogen recovery unit 481 is a stream 483 of rejected syngas. The stream 483 can be recycled to join the stream 428.

[0086] In the preferred embodiment, the hydrogen recovery unit (HRU) 481 extracts H₂ using a combination membrane and pressure swing adsorption (“PSA”) system. The HRU membrane retentate gas is re-mixed with the bulk syngas stream and sent to the F-T Liquids Reactors. The HRU PSA purge gas is routed to the suction of the Syngas Compressor 431 and the purified H₂ stream 482 is sent to upgrading.

[0087] As illustrated in **FIG. 5**, a system 33 for generating F-T liquids receives the syngas feed stream 31. The system includes one or more F-T reactors 533 and provides, as mentioned above, the fluids output stream 535 that comprises F-T liquids and F-T tail gas. The F-T reactor output stream 535 is fed into a thermal separation system generally designated by the numeral 500 to separate the F-T liquid into its heavy F-T liquid (HFTL), medium FT liquid (MFTL), water and the F-T tail gas.

[0088] In the preferred embodiment as illustrated in **Fig. 5**, the thermal separation system 500 includes two condensers 501 and 531 and two separators 503 and 504. The HFTL separator 503 has outlets 518 and 520, respectively. In practice, the condenser 501 operates using a tempered hot water loop as the cooling medium to condense and separate the HFTL

liquid fraction from the F-T water and MFTL liquid fraction. Both the MFTL Water and the FT Tail gas remain in a vapor phase. The HFTL stream is carried by the outlet 520 for storage in tank(s) 521 for further processing. In practice, the HFTL stream 520 is composed primarily of heavy hydrocarbon waxes which are solid at room temperature. These waxes are kept warm above 230°F to prevent solidification.

[0089] Also as illustrated in **Fig. 5**, the thermal separation system 500 includes the second condenser 531 that receives, via the stream 518 from the HFTL separator 503, the F-T water and MFTL. In practice, the second condenser 531 uses cooling water to condense and separate the F-T water and MFTL from unreacted syngas and non-condensable hydrocarbons (i.e., methane, etc.). The condensed F-T water and MFTL stream phase split in the second separator 504, with the MFTL stream routed to storage unit(s) 522 via stream 540 and the F-T water routed to waste water treatment via a stream 542.

[0090] As **Fig. 5** further shows, the F-T tail gas can be recycled to the F-T reactors 533 via a stream 537. In the illustrated embodiment, the F-T tail gas is separated at the MFTL separator 504 and carried by stream 550 to a compressor 511 whose output is conveyed on the syngas recycle line 537. Prior to the recycle compressor 511, a purge stream 552 branches off of stream 550. The purge stream 552 can be directed to both the hydrocarbon reformer 215 via stream 25 (**Fig. 2**) to control hydrocarbon content in the recycle syngas and to the power boiler to purge inerts from the recycle syngas.

[0091] **Fig. 6** shows an example of one embodiment of the upgrading system 54 of **Fig. 1**. More particularly, this figure illustrates a system for producing refined F-T liquids from the system of **FIG. 5**. The illustrated system includes a hydrocracker reactor unit 643 which receives liquids from hydrocracking charge vessel 524 fed by the aforementioned tanks 521 and 522 (**Fig. 5**). In the preferred embodiment, the hydrocracker reactor unit 643 employs a high temperature, high pressure catalytic process that upgrades the HFTL and MFTL

hydrocarbon streams into a transportation fuel (SPK or Diesel). Due to the low severity of the upgrading, the hydro-processing and hydrocracking occur in one reactor. The olefins and alcohols are first saturated and then the alkanes are cracked into the SPK range of products. The hydrocracking mechanism, which involves a protonated cyclopropane intermediate, forms an isomer product along with a straight chained product. In the hydrocracker reactor unit 643, the feed mixture passes through a series of catalyst beds for conversion into shorter chained hydrocarbons.

[0092] In an alternative embodiment, the pre-fractionate the MFTL can be pre-fractionated and there can be removal of the light fraction overhead to the hydrocarbon reformer; then, the heavy fraction along with the HFTL would be conveyed to the hydrocracker for upgrading. This embodiment removes most of the oxygenates from the stream flowing to the hydrocracker and lessens the hydrotreating load on the hydrocracker.

[0093] As further illustrated in **Fig. 6**, the hydrocracker reactor unit 643 provides the output stream 644 which is fed to a hydrocarbon thermal separation system generally designated by the numeral 701 wherein the crackate is cooled, condensed, and separated into two separate heavy and light crackate streams, using a series of heat exchangers and separator vessels.

[0094] In the illustrated embodiment of the, hydrocarbon thermal separation system 701, the crackate is cooled in a feed/effluent heat exchanger 702 and the heavy crackate is separated from the light crackate in a heavy crackate separator 703. From the heavy crackate separator 703, the heavy crackate syncrude is routed to a fractionator 853, as by streams 704 and 750. In addition, some of the heavy crackate can be recycled to the hydrocracker 643 to keep material flowing into the hydrocracker during startup and when the fractionation column is malfunctioning.

[0095] In the illustrated embodiment, a light crackate separator 705 is provided for separating the light crackate from heavy crackate water and hydrogen. The separated light crackate is routed to the fractionator 853 by stream 750. The heavy crackate water is sent, as by line 706, to the bio-refinery's waste water treatment plant for treatment. The separated hydrogen gas is routed to recycle as by streams 708, 741 and 742.

[0096] The fractionation process in **Fig. 6** will now be described in greater detail. As previously mentioned, the fractionator 853 receives a stream 704 of heavy crackate liquids and a stream 750 of light crackate liquids. The purpose of the fractionator 853 is to separate the SPK or Diesel cut from the heavy crackate fraction and the naphtha fraction. The side draw stream 856 is fed into a stripper column 857 to remove lights from the SPK/Diesel feed and provide final clean up and recovery of the SPK/Diesel products. In the fractionator 853, the incoming heavy and light crackate streams are combined and heated by natural gas fired heater for an initial separation in the fractionator column. Preferably, the fractionator 853 uses direct steam injection to strip the low boiling hydrocarbons from the high boiling hydrocarbons without utilizing a high temperature reboiler configuration.

[0097] The outputs from the fractionator 853 include overhead stream 23 that carries recyclable hydrocarbon products. Preferably, the overhead stream 823 which is provided into a condenser unit 860 where the stream is condensed and separated into three streams: main fractionator ("MF") water stream 862, the afore-mentioned light phase (naphtha) stream 231, and offgas stream 233. In practice, the naphtha can be refluxed back into the fractionator 53 and/or sent to a Naphtha Vaporizer for injection into the hydrocarbon reformer. The offgas stream 233 is recycled by the off gas compressor to the hydrocarbon reformer for reprocessing. The bottoms from the fractionator column 853 are pumped to the hydrocracking charge vessel 560, as by stream 855, for additional hydrocracking. MF Water is sent to the bio-refinery's wastewater treatment plant for treatment.

[0098] Naphtha from the Fractionator OH Separator is pumped into the Naphtha Vaporizer where it is vaporized using low-pressure steam. The naphtha vapor then flow into the hydrocarbon reformer 215 of **Fig. 2** for recovery. The fractionation column overhead pressure floats on the offgas Compressor discharge rate. The offgas Compressor provides motive force to move the Fractionator Overhead Separator offgas into the discharge of the Naphtha Vaporizer. The combined streams then flow into the hydrocarbon reformer.

[0099] The SPK product, withdrawn by the steam 856 from the upper part of the fractionator 853, is sent to the Product Stripper column 857 for final product separation. The heat to the product Stripper column 857 is provided, for example, by a natural gas fired Product Stripper Reboiler. The Product Stripper overhead stream recycles back to the Fractionator 853. The bottoms stream 800 is cooled and sent, via the stream 58, to storage unit 803 as the SPK product.

[0100] As shown in **Fig. 4A**, one embodiment of an exemplary CO₂/H₂S removal system 461 includes a sulfur removal unit 463 that receives the stream 460. One output of the sulfur removal unit 463 is a stream 464 of sulfur. Another output of the removal unit 463 is a stream 466 of syngas from which sulfurs have been removed.

[0101] The syngas stream 466 is fed to an amine solvent system, generally indicated by the numeral 491. In the illustrated embodiment, the amine solvent system 491A comprises an absorber unit 493 and a regenerator unit 495 connected in counter-current relationship. The output of the regenerator unit 493 is the aforementioned syngas feed stream 470. The output of the absorber unit 495 is the aforementioned stream 27 of recycled CO₂.

[0102] In the preferred embodiment of **Fig. 4A**, the absorber unit 493 is a column where CO₂ is removed by contact with a circulating amine/water solution. In this embodiment the amine absorber can remove H₂S from stream 466 in the event the sulfur removal unit under performs. The treated syngas is water washed to remove any entrained amine solution. In

the preferred embodiment, the cleaned syngas leaving the solvent absorber 493 is heated using Medium Pressure (MP) saturated steam and routed, as stream 470, to the guard bed to removal trace H₂S and arsenic catalyst poisons prior to introduction into the F-T synthesis process.

[0103] As shown in **Fig. 4B**, another exemplary CO₂/H₂S removal system 461 includes an amine unit where syngas stream 460 is fed to an amine solvent system, generally indicated by the numeral 491B. In the illustrated embodiment, the amine solvent system 491B comprises an absorber unit 493 and a regenerator unit 495 connected in counter-current relationship. The output of the regenerator unit 495 is fed to the sulfur removal unit 463. The output of the absorber unit 493 is the aforementioned syngas feed stream 470. In this embodiment, the absorber unit 493 is a column where CO₂ and H₂S is removed by contact with a circulating amine/water solution. The treated syngas is then water washed to remove any entrained amine solution and sent, as stream 470, to the final guard beds 471.

[0104] In embodiment of **Fig. 4B**, the regenerator overhead output stream 466 is fed to the sulfur removal unit 463 where the H₂S is removed from the reject CO₂ stream. One output of the sulfur removal unit 463 is the aforementioned stream 27 of recycled CO₂ and a stream 464 of sulfur. A portion of the overhead CO₂ reject stream from the Sulfur Removal unit is compressed and recycled back the gasification island and the excess is vented to the atmosphere.

[0105] In operation of CO₂/H₂S removal system in **Figs. 4A** and **4B**, “rich” amine (i.e., amine after absorption of CO₂) from the absorber column passes through a lean/rich exchanger and then flashes into the Rich Solvent Flash Drum. The flashed gas, rich in CO and H₂, flows to the suction of the syngas compressor for reuse in the process. The flashed rich liquid stream flows to the Solvent Regenerator column. In the Solvent Regenerator, the rich solvent is heated in a steam reboiler, driving off the absorbed CO₂/H₂S. The “leaned”

solvent flowing out the bottom of the Solvent Regenerator is recirculated back via the lean/rich exchanger and the solvent cooler to the Absorber for reuse. A portion of the overhead CO₂ reject stream from the Solvent Regenerator is compressed and recycled back the gasification island and the excess is vented to the atmosphere. Preferably, the system is designed to reduce the CO₂ content in the syngas stream to <1 mol% and the H₂S content to <5ppmv, while minimizing the loss of CO and H₂.

[0106] In the overall operation of the above-described system, multiple reactions take place as MSW is gasified. The major reaction occurs at elevated temperatures when char (carbon) reacts with steam to produce syngas primarily made up of hydrogen (H₂), carbon monoxide (CO), carbon dioxide (CO₂), and some hydrocarbons:

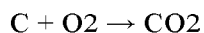
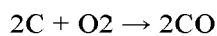
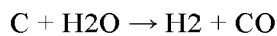

Simultaneously, the reversible “water gas shift” reaction

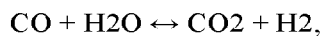

approaches equilibrium conditions with the CO/ H₂O and the CO₂/ H₂ ratios based on the equilibrium constant at the gasifier operating temperature. The gasification system may be configured, and conditions provided, so that at least the following gasification reaction occurs:

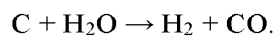

Simultaneously, conditions may preferably be provided so that the following reversible “water shift” reaction reaches an equilibrium state determined mainly by the temperature of the gasifier, the pressure preferably being near atmospheric:

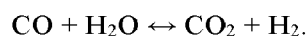

The primary FT reaction converts syngas to higher molecular weight hydrocarbons and water in the presence of a catalyst:

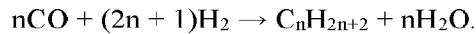

[0107] Further as to the overall operation of system, it should be noted that the syngas produced in the gasification island 21 has an insufficient quantity of hydrogen for the effective production and upgrading of F-T liquids. The Sour shift reactor 441 generates additional hydrogen to increase the H₂:CO ratio in the syngas from about 0.8 to approximately 2.0. The water gas shift reaction converts a portion of the CO and H₂O in the syngas to H₂ and CO₂. The reaction is exothermic and occurs over a sour shift catalyst. The reaction is a “sour shift” as H₂S is still present in the syngas stream. Utility steam and steam generated by the Shift Reactor 441 are mixed with the syngas to provide the water for the water-gas shift reaction and to moderate the temperature rise in the reactor. Hydrogen production and the syngas H₂:CO ratio are controlled by bypassing a portion of the syngas stream around the Shift Reactor. The Shift Reactor effluent heat is recovered by interchanging with the reactor influent syngas, generating shift reactor steam, and pre-heating boiler feed water.

[0108] Referring to **Figs. 7 – 12**, additional embodiments of a feedstock processing system (also sometimes referred to as a feedstock processing facility (FPF)) 1000 are shown. **Fig. 7** is a schematic diagram illustrating one embodiment of a feedstock processing system 1000 and an associated method. While **Fig. 7** and the description refer to a specific example using MSW feedstock, such example is for illustrative purposes only and the present invention is not limited to any specific example. It will be understood by those of ordinary skill in the art that other initial or raw feedstocks may be used and processed in the system 1000.

Additionally, the terms “raw” or “initial” or “incoming” are used interchangeably to describe feedstock or material that is input or fed to the system 1000. These terms are for convenience

do not limit the content or character of the feedstock or material input or fed to the system 1000. For example, the feedstock or material input to the system 1000 may be subject to prior processing and then sent to the system 1000 for further processing. The feedstock input to the system 1000 may be sent directly from a municipality without prior processing. In the example of woody biomass feedstock, this feedstock may be shredded or cut prior to being input to the system 1000, although not necessarily. Those of ordinary skill in the art will recognize that many types of feedstock or material may be input to the system 1000, and that the invention is not limited to any particular type or delivery.

[0109] In general, the feedstock processing system 1000 may be configured to process feedstock or other material, such as waste, to produce processed feedstock having selective biogenic carbon content. The feedstock processing system 1000 provides flexible processing of one or more feedstocks to generate a processed feedstock tailored to a specific facility, application or need. For example in some embodiments, the feedstock processing system 1000 may be configured to optimize or maximize recovery of biogenic carbon material from the raw or initial feedstock input to the system 1000 to produce a processed feedstock having high biogenic carbon content. In other embodiments, the biogenic carbon content in the processed feedstock is selectively controlled to be in a specific range and is not necessarily maximized. For example, it may be desirable to produce a processed feedstock that contains a certain amount of non-biogenic carbon material, such as but not limited to carbon derived from plastics, in addition to biogenic carbon material. And in further embodiments, it may be desirable to process greater content of non-biogenic carbon material, such as end of life plastics, such that the biogenic carbon content of the processed feedstock is less than 50% by weight. As noted above, all percentage (%) values are weight percent (wt. %) unless indicated otherwise.

[0110] In general, the feedstock input to the system 1000 may be any type of material. In some embodiments, the feedstock will include organic waste material. For purposes of this disclosure the term organic waste materials or waste is broadly understood and intended to include any organic or carbonaceous material, such as but not limited to MSW, woody biomass, cellulosic material, plastics, and the like.

[0111] Generally for purposes of this disclosure, the term “high” biogenic carbon with respect to the processed feedstock is made up of at least 51% biogenic carbon material by weight. Embodiments of the feedstock processing system 1000 may be configured to produce processed feedstocks having a biogenic carbon content in the range of 50% to 100%. In other embodiments, the feedstock processing system 1000 may be configured to produce processed feedstocks having a biogenic carbon content in the range of 51% to 95%. Alternatively, the feedstock processing system 1000 may be configured to process plastics to produce a processed feedstock having biogenic carbon content in the range of 50% or less.

[0112] The feedstock processing system 1000 may be configured to process a large variety of feedstock material input into the system 1000 by one or more feedstock streams 1200. In some embodiments, the feedstock material 1200 may include mixed solid waste, such as wet organic waste, dry organic waste and inorganic waste that is comingled in one or more waste streams. In other embodiments, the feedstock material may include biomass materials, such as woody biomass or vegetative material, or mixtures thereof. In another embodiment, the feedstock may include plastics. The plastics can be mixed in with mixed solid waste or can be input in a separate waste stream (as shown in **Figs. 11 and 12** as described further below). Those of ordinary skill in the art will recognize that the feedstock material input into the system 1000 is not intended to be limited, the only criteria being that the feedstock material contain some amount of carbonaceous material.

[0113] As illustrated in **Fig. 7**, feedstock or material 1200 may be transferred to the feedstock processing facility or system 1000. In this example, the feedstock 1200 is comprised of MSW. For example, feedstock 1200 may be delivered by transfer trucks and unloaded onto floor sort 1210 to be sorted. In the exemplary embodiment, at the floor sort 1210 the oversize bulky waste, such as water heaters, refrigerators, propane tanks, large metal pieces, etc., hazardous items, and other items incompatible with the remainder of the processing train may be removed in stream 1202 to heavy residual material storage 1290, producing stream 1205. Note that heavy residual material storage unit 1290 is also sometimes reference to as simply residual material storage 1290 or sometimes as inert material station 1290. The floor sort 1210 separates the larger material from smaller material. In one embodiment, material sized at 10 inches and over is separated from the smaller material (material sized at less than 10 inches) to produce stream 1205. Other sizes may be used to differentiate between large and small material.

[0114] After this initial sort, the MSW (stream 1205) may be fed into a size reduction unit 1230 where the 10 inch and over material in stream 1205 may be reduced. For example, the size reduction unit 1230 may include a conveyor (not shown) feeding a shear-type (or equal) shredder. The MSW (stream 1205) may be shredded to a minus 10-inch size producing material in stream 1235. The size reduced/shredded MSW in stream 1235 may be sent to fractionation unit 1240. Any suitable type of fractionation device may be implemented herein. The fractionation unit 1240 may be used to remove non-biogenic carbons along with other non-carbonaceous materials from the stream 1235 to produce stream 1245. Stream 1245 may include biogenic carbon material and other carbonaceous materials. The reject stream 1242 from fractionation unit 1240 may range in size from 1-4 inches and contain a high percentage of non-carbonaceous material. Any suitable type of fractionation unit may be implemented. For example, stream 1245 may be screened in a cascading finger-type

screen unit 1240 to remove fine material smaller than two inches. The fine materials may include dirt, glass, wet organics, and other inerts. Wet organics may include, for example, grass clippings and food waste. For purposes of this description, the term inert material or “inerts” refers to any non-carbonaceous material.

[0115] Material in stream 1245 is further processed in ~~fine~~-fractionation density separation unit 1250, which is configured to separate the heavy/medium fraction from the light fraction in stream 1245. The heavy/medium fraction containing materials such as dirt, gravel, glass, metal, yard waste, and food waste may be separated as stream 1255 from a light fraction (Density separation ratios in the range of 2:2 to 5:1) and sent to a residual material station 1290. The light or fine fraction in stream 1257 typically contains the carbonaceous materials such as paper, plastic and textiles. A suitable type of unit for the fine fractionation would be a density type air separation unit.

[0116] MSW stream 1257 output from the fine fractionation and density separation unit 1250 can be further processed by removing ferrous material in ferrous removal unit 1270 (also sometimes referred to as magnetic separators). Magnetic separators in the ferrous removal unit 1270 remove the ferrous metals to produce a high carbonaceous material output (stream 1277). The ferrous materials separated in stream 1275 can be recovered at recovered metals station 1278 and ultimately to a recycling station.

[0117] MSW stream 1277 output from ferrous removal unit 1270 can be further processed by removing non-ferrous metal materials in non-ferrous removal unit 1280, to produce a higher carbonaceous MSW output stream 1287. The non-ferrous metal materials separated in stream 1285 can be recovered at recovered non-ferrous metals station 1288 and ultimately to a recycling station. The non-ferrous metals 1288 may include, for example, aluminum, copper, and non-magnetic steel. In some embodiments, eddy current separators may be used to remove non-ferrous metals to produce the high carbonaceous material output stream 1287.

[0118] Additionally, MSW stream 1287 may be further processed to remove and recover plastics from stream 1287 in plastic removal unit 1300 to produce MSW output stream 1307. The plastic removal unit 1300 may include a set of near-infrared optical sorters configured to separate out plastics in stream 1305. The plastics 1305 may include but not limited to a mixture of a polyethylene terephthalate (“PET”) plastic stream and a combined polyvinyl chloride (“PVC”) and high-density polyethylene (“HDPE”) and low-density polyethylene (LDPE) plastics stream. Polystyrene (“PS”) and polypropylene (“PP”) may be recovered with the HDPE/PVC stream by adjusting the optical sorter setting. The separated plastics in stream 1305 may be baled and stored at a recovered plastics station 1308 for off-site shipment and sale.

Now that the inerts, ferrous metals, non-ferrous metals, “wet” organics and plastics are removed from the processed feedstock stream 1307, carbonaceous material in stream 1307 is fed into a second size reduction unit 1310 for final comminuting. The material in stream 1307 may be comminuted to any desired size depending on the requirements for the final processed feedstock. For example, the feedstock material may be shredded to a size in the range of 0.75 to 1.5 inches depending on process requirements.

[0119] Once comminuted to the desired size, the sized processed feedstock material in stream 1315 is typically dried in a drying unit 1320 to feedstock specification to produce a final processed feedstock in stream 1325. The final processed feedstock stream 1325 may be transferred to a bio-refinery where it is converted into F-T liquids and liquid fuels, as discussed above. In some embodiments the final processed feedstock may be made up of material sized in the range of 0.75 to 1.25 inch. The final processed feedstock has low moisture content, generally in the range of about 8% – 15%. Specifically, the final processed feedstock may have a low moisture content less than about 10%. The final processed feedstock may include low inert material content. For example, the low inert material content

may be in the range of 0.5 – 2.5%. Alternatively, the low inert material content may be less than 2%. The recovery of carbonaceous material is between 35-40%

[0120] **Fig. 8** is a schematic diagram illustrating an alternative embodiment of a feedstock processing system 1020 and associated method. The embodiment in **Fig. 8** provides for greater recovery of carbonaceous material from the initial feedstock and produces a more processed final feedstock 1325 than the embodiment illustrated in **Fig. 7**.

[0121] In general, the feedstock processing system 1020 may be configured to process raw feedstock, such as waste, to produce a processed feedstock having selective biogenic carbon content. The feedstock processing system 1020 provides flexible processing of raw feedstock to generate a processed feedstock tailored to a specific facility, application or need. The feedstock processing system 1020 of **Fig. 8** includes similar components of the feedstock processing system 1000 of **Fig. 7**, with the following additions and or differences to further process the feedstock.

[0122] For example, feedstock processing system 1020 as shown in **Fig. 8** may include a rough separation unit 1220. After initial sort, the MSW stream 1205 may be fed into a rough separation or initial size separation unit 1220 where larger material is separated from smaller material in a rough separation. In one embodiment, the larger material (e.g., material sized at 10 inches and over) may be separated into stream 1225. The smaller material (e.g., material sized at less than 10 inches) is separated into stream 1215. Other sizes may be used to differentiate between large and small material.

[0123] The larger material in stream 1225 is fed into a size reduction unit 1230 where the 10 inch and over material in stream 1225 is further comminuted by being fed onto a conveyor (not shown) feeding a shear-type shredder. The shear-type shredder may shred the larger material to a minus 10-inch size producing material. The shredded minus 10-inch size MSW material is produced in stream 1235.

[0124] The smaller material in stream 1215 (e.g., 10 inch under material) is sent from the rough separation unit 1220 to a fractionation density separation unit 1260 where the heavy/medium fraction is separated from the light fraction. The heavy/medium fraction is separated into stream 1267 and generally contains materials such as dirt, gravel, glass, metal, yard waste, and food waste. The lighter fraction is separated into stream 1265 and generally contains paper, plastics and textiles and other carbonaceous material. Density separation ratios in the range of 2:2 to 5:1 are achievable to separate the lighter fraction from the heavy fraction.

[0125] The heavy/medium fraction stream 1267 is sent to the first fractionation density separation unit 1250 where it combines with stream 1245. The light fraction (stream 1265) from the density fractionator 1260 may contain paper, plastics and textiles may be sent to a final comminuting step at 1310 where it is mixed with other product streams prior to drying the feedstock product. This embodiment increases the recovery of carbonaceous material to between 44-50%

[0126] **Fig. 9** is a schematic diagram illustrating an alternative embodiment of a feedstock processing system 1030 and associated method. The embodiment in **Fig. 9** increases the recovery of carbonaceous material from stream 1200 to around 50-55% and produces greater processed final feedstock 1325 than the embodiments illustrated in **Fig. 7** and **Fig. 8**. The feedstock processing system 1030 of **Fig. 9** includes similar components of the feedstock processing system 1020 of **Fig. 8**, with the following additions and or differences to further process the feedstock.

[0127] To provide additional recovery of carbonaceous material from the feedstock, system 1030 includes additional fine fractionation units. In the example shown, three fractionation density separation units are used; two primary and one secondary units. The primary units 1250 and 1260 are configured as described in feedstock processing system

1020. A secondary fractionation density separation unit 1244 is configured to increase the recovery of the carbonaceous material from the reject stream 1242 of the fractionation unit 1240. In this embodiment, the basic fractionation unit 1240 produces two output streams 1242 and 1245 of differing size. Generally, output stream 1242 contains smaller fine material (<two inches) which is sent to the secondary fractionation density separation unit 1244 where the material is classified based on density to recover some of the carbonaceous material from stream 1242 that was screened out with the inert fraction in fractionation unit 1240. The materials in stream 1242 that were removed in unit 1240 may include paper, textiles, in addition to dirt, glass, wet organics, and other inerts. Wet organics may include, for example, grass clippings and food waste. The heavy/medium fraction from unit 1244, stream 1246 is sent to the residual material and the light fraction, stream 1248 is combined with the light fraction from unit 1250 and sent to the ferrous removal unit 1270. The light fraction (stream 1248) from the secondary density fractionator 1244 may contain paper, plastics and textiles. For purposes of this description, the term inert material 1202, 1246 and 1255 or “inerts” refers to any non-carbonaceous material. The inert material 1202, 1246 and 1255 is sent to an inert material station 1290. The inerts may be removed to produce a high carbonaceous material output (streams 1248 and 1257). Streams 1248 and 1257 are sent to the ferrous removal station 1270 and further processed as described above with respect to **Fig. 7 and 8.**

[0128] **Fig. 10** is a schematic diagram illustrating an alternative embodiment of a feedstock processing system 1040 and associated method. The embodiment in **Fig. 10** recovers even more carbonaceous material from the initial feedstock and produces a more processed final feedstock 1325 than the embodiments illustrated in **Figs. 7, 8 and 9.** The embodiment in **Fig. 10** produces greater processed final feedstock 1325 (55-60% recovery) than the embodiments illustrated in **Figs. 7, 8 and 9.** By adding additional processing steps,

greater recovery of the carbonaceous material from the original feedstock 1200 stream may be achieved. The feedstock processing system 1030 of **Fig. 10** includes similar components of the feedstock processing system 1030 of **Fig. 9**, with the following additions and or differences to further process the feedstock.

[0129] The feedstock processing system 1040 includes one additional secondary fractionation density separation units 1090 downstream from one of the primary fractionation density separation unit 1260. The inert stream 1267 from primary fractionation density separation unit 1260 is sent to the secondary fractionation density and separation unit 1090 to recovery additional carbonaceous material. More carbonaceous material is recovered when operating two fractionation density separation devices in series due to the wider density range achievable. - The inert material 911 will be sent to residue material station 1290 and the carbonaceous material stream 912 is sent to the first fractionation density separation unit 1250 where it combines with stream 1245. Operations downstream of unit 1260 are described illustrated above in Figures 8 and 9.

[0130] In a further aspect of the present inventions, a feedstock processing system is provided configured to process multiple initial feedstock streams containing carbonaceous material. **Fig. 11** is a schematic diagram illustrating an alternative embodiment of a feedstock processing system 1050 and associated method. **Fig. 11** is an example of a feedstock processing system configured to process multiple feedstock streams, and feedstock streams of different types.

[0131] In general, the feedstock processing system 1050 is be configured to process one or more initial or raw feedstock streams to produce processed feedstock having selective biogenic carbon content. The feedstock processing system 1050 provides flexible processing of multiple feedstocks to generate processed feedstock tailored to a specific facility, application or need. The feedstock processing system 1050 of **Fig. 11** includes some similar

components of the feedstock processing system 1040 of **Fig. 10**, but with the following differences and/or additions.

[0132] Feedstock processing system 1050 is configured to receive and process recovered plastics 1201 (such as previously recovered or recycled plastics) and/or woody biomass 1202 in addition to other carbonaceous feedstock 1200, such as MSW. The recovered plastic 1201 may include without limitation a mixture of a polyethylene terephthalate (“PET”) plastic stream and a combined polyvinyl chloride (“PVC”) and high-density polyethylene (“HDPE”) and low-density polyethylene (“LDPE”) plastics stream. The woody biomass 1202 may include without limitation wood bio-mass, straw, switch grass, construction and demolition waste, and other like biomass materials. The plastic 1201 and woody biomass 1202 streams may be separately input into the system 1050 as shown in **Fig. 11**, or the streams may be mixed and then input into the system in one feedstream. In the exemplary embodiment, plastic 1201 and woody biomass 1202 streams are sent to a size reduction unit 1203 where the 10 inch and over material in plastic 1201 and woody biomass 1202 is comminuted by being fed onto a conveyor (not shown) feeding a shear-type (or similar) shredder. The shear-type shredder may shred the larger material to a minus 10-inch size producing material. The shredded minus 10-inch size MSW material is produced in stream 992.

[0133] The shredded material may be sent to a fractionation density separation unit 1150 where the light/medium fraction is separated from the heavy materials. The heavy materials may include dirt, glass, wet organics, and other inerts. Wet organics may include, for example, grass clippings and food waste. The inert material 996 may include any non-carbonaceous material. The inert material 996 may be sent to the residual material station 1290. After many of the inerts are removed, stream 994 is produced. The light/medium fraction (stream 994) may be sent to ferrous removal unit 1270 (also sometimes referred to as magnetic separators) and mixed with other streams for removal of ferrous material from

streams 1248, 1257 and 1265, and then continue through the process steps as described above. Thus, in this embodiment additional carbonaceous waste feedstocks are processed to provide a processed feedstock 1325 that is then used to create F-T liquids and transportation fuels.

[0134] **Fig. 12** is a schematic diagram illustrating an alternative embodiment of a feedstock processing system 1060 and associated method. **Fig. 12** is an example of a feedstock processing system configured to process multiple feedstock streams, and feedstock streams of different types, and further provides anaerobic digesters to recover methane from the system 1060.

[0135] In general, the feedstock processing system 1060 may be configured to process feedstock, such as waste, to produce a processed feedstock having selective biogenic carbon content. The feedstock processing system 1060 provides flexible processing of feedstock to generate a processed feedstock tailored to a specific facility, application or need. The feedstock processing system 1060 of **Fig. 12** includes similar components of the feedstock processing system 1050 of **Fig. 11**, but with the following addition of an anaerobic digester configured to recover methane from the rejected material in the residual material unit 1290.

[0136] As illustrated in **Fig. 12**, the reject material from the various streams 996, 1246, 911 and 1255 fed to the residual material station 1290 are output in stream 1295 and sent to an anaerobic digester station 1296. Anaerobic digestion may include a process in which microorganisms break down biological material in the absence of oxygen. The anaerobic digester station 1296 may include one or more anaerobic digesters, used to digest sewage biosolids, low solids or screened animal manure, and low suspended solids or high soluble solids as in anaerobic filters or upflow sludge blanket digesters. The digesters can also be used to digest particulate organic wastes, especially solid wastes (the digestible fraction of municipal wastes) including pre-consumer and post-consumer food wastes, such as fats, oils

and greases, food processing wastes, yard trimmings, leaves, paper, and other inerts from the residual material station 1290. The anaerobic digester station 1296 produces a biogas (methane) byproduct 1297 which is recovered and used as an energy source for process heating.

[0137] The four basic stages of anaerobic digestion to produce a biogas (methane) byproduct are: (1) hydrolysis of large particulate solids; (2) fermentation of large polymers into intermediates, i.e. acids and alcohols; (3) conversion of these acids and alcohols into carbon dioxide, hydrogen and small chain fatty acids, e.g. acetates; and (4) reduction of carbon dioxide, hydrogen and acetates into methane. Hydrolytic bacteria may be used as the digestive biomass to produce enzymes for the breakdown of all the various solids into smaller particles, then liquids releasing carbon dioxide and hydrogen into the fermentation liquor. The enzymes produced by the hydrolytic bacteria may cleave the large polymers of cellulose, protein, and fat.

[0138] Thus, in this embodiment the carbonaceous portion of the material in the residual material unit 1290 are processed to generate biogas (methane) which can be used as an energy source for process heaters or recycled back the gasification island to be reformed into syngas that is then used to create F-T liquids and transportation fuels. Methane generated in the landfill from the residual material is reduced and carbon recovery is maximized.

[0139] The creation of fuel from feedstocks of MSW, woody biomass, plastics and other carbonaceous feedstocks by the above-described system has significant advantages. It provides an energy efficient system with a very low emissions profile, reduces MSW and plastics and other materials entering landfills (thus dramatically reducing harmful methane gas emissions from landfills and mitigating the need for new or expanded landfills), reduces by displacement greenhouse gases associated with the use of petroleum and coal derived fuel

products. The system increase the biogenic content of cellulosic-based fuels and, therefore, substantially increases the value of such fuels.

[0140] Exemplary embodiments have been described with reference to specific configurations. The foregoing description of specific embodiments and examples has been presented for the purpose of illustration and description only, and although the invention has been illustrated by certain of the preceding examples, it is not to be construed as being limited thereby.

CLAIMS

1. A method for processing feedstock, characterized in that incoming feedstock is processed to selectively recover biogenic carbon material from the incoming feedstock.
2. The method of claim 1, wherein the incoming feedstock is comprised of mixed solid waste.
3. The method of claim 1, wherein in the incoming feedstock is comprised of woody biomass.
4. The method of claim 1, wherein the mixed solid waste is municipal solid waste (MSW).
5. The method of claim 2, wherein the mixed solid waste is comprised of wet organic waste, dry organic waste and inorganic waste that is comingled.
6. The method of claim 1, wherein the incoming feedstock is processed to selectively recover biogenic carbon material from the incoming feedstock to produce a processed feedstock having biogenic carbon content of 50% and greater suitable for conversion into biogenic carbon Fischer Tropsch liquids.
7. The method of claim 6, wherein the high biogenic carbon Fischer Tropsch liquids are upgraded to biogenic carbon liquid fuels.
8. The method of claim 5, further comprising:

separating the comingled mixed solid waste into a first stream containing mixed solid waste material having a predetermined size and larger, and a second stream containing mixed solid waste material having the predetermined size and smaller.

9. The method of claim 8, further comprising:

comminuting the first stream to produce an output stream containing mixed solid waste having the predetermined size and smaller.

10. The method of claim 9, further comprising:

combining the output stream and the second stream to produce a combined stream,
and

fractionating the combined stream by size to remove small size, low carbon content material having a size of 2 inches and smaller from high carbon content material.

11. The method of claim 10, further comprising:

further fractionating the high carbon content material (overs) to remove inert material to produce a carbonaceous material stream.

12. The method of claim 11, further comprising:

comminuting the carbonaceous material stream to produce an output stream containing carbonaceous material having a size of 1 inch and smaller.

13. The method of claim 12, further comprising:

drying the output stream to produce a processed feedstock containing carbonaceous material and a moisture content in the range of 8% to 15%.

14. The method of claim 11, wherein the incoming feedstock is processed to selectively recover plastic material from the incoming feedstock to produce a processed feedstock having biogenic carbon content of 50% or less.

15. The method of claim 13, wherein the processed feedstock contains biogenic carbon content in a range of 50% to 100%.

16. The method of claim 13, wherein the processed feedstock contains 51% and greater biogenic carbon content.

17. The method of claim 8, wherein the step of separating the comingled mixed solid waste is carried out using a trommel.

18. The method of claim 9, wherein the step of comminuting is carried out using a shredder with a shredder opening in a range of 6 – 15 inches.

19. The method of claim 10, wherein the step of fractionating the combined stream is carried out through a vibratory screen, and where the 2 inch and smaller fraction is removed for further fractionation into an inert low biogenic carbon material and a high biogenic content material.

20. The method of claim 11, wherein the further fractionating step is carried out through an air separator wherein a heavy fraction is separated from a light fraction by differences in density.

21. The method of claim 20, wherein the heavy fraction from the air separator is further fractionated in another air separator wherein the heavy fraction is further separated into a medium fraction and a heavy-heavy fraction by differences in density.

22. The method of claim 21, wherein the heavy-heavy fraction is removed as inert low biogenic material.

23. The method of claim 21, wherein the light fraction is combined with the medium fraction and the combined stream is passed over a magnet to remove ferrous material from the combined stream.

24. The method of claim 20, wherein the heavy fraction is further fractionated through a vibratory screen to remove non-carbonaceous (i.e. inert) material having a size of 1 inch and smaller.

25. The method of claim 21, wherein the light fraction, medium fraction and heavy fraction are combined to produce a combined fraction stream and then passed through an eddy current to remove non – ferrous material.

26. The method of claim 25, wherein the combined fraction stream is passed through an optical sorter to remove at least a portion of plastic content in the combined fraction stream, to produce a processed feedstock.

27. The method of claim 26, wherein the plastic content in the combined fraction stream is selectively removed such that processed feedstock has a biogenic carbon content of up to 95%.

28. The method of claim 26, wherein the plastic content in the combined fraction stream is selectively removed such that processed feedstock has a biogenic carbon content of up to 50%.

29. The method of claim 26, wherein the plastic content in the combined fraction stream is selectively removed such that processed feedstock has a biogenic carbon content of 51% and greater.

30. The method of claim 26, wherein the plastic content in the combined fraction stream is selectively removed such that processed feedstock has a biogenic carbon content between 50% and to 95%.

31. A system for processing incoming feedstock to selectively recover biogenic carbon material from the incoming feedstock, the system comprising:

a sorting station configured to separate the incoming feedstock into a first stream containing mixed solid waste material having a predetermined size and larger, and a second stream containing mixed solid waste material having the predetermined size and smaller;

a first comminution unit in communication with the sorting station and configured to comminute the first stream to produce an output stream containing mixed solid waste having the predetermined size and smaller, and combine the output stream and the second stream to produce a combined stream;

a fractionation unit in communication with the commination unit and configured to fractionate the combined stream by size to remove small size, low carbon content material having a size of 2 inches and smaller from high carbon content material;

a fine fractionation density unit in communication with the fractionation unit and configured to further fractionate the high carbon content material to remove inert material to produce a carbonaceous material stream;

a ferrous removal unit in communication with the fine fractionation density unit configured to remove ferrous material from the carbonaceous material stream;

a non-ferrous removal unit in communication with the ferrous removal unit and configured to remove non-ferrous material from the carbonaceous material stream;

a plastic removal unit in communication with the non-ferrous removal unit and configured to remove plastic material from the carbonaceous material stream;

a second commination unit in communication with the plastic removal unit and configured to comminute the carbonaceous material stream to produce an output stream containing carbonaceous material having a size of 1 inch and smaller; and

a drying unit in communication with the second commination unit and configured to dry the output stream to produce a processed feedstock containing carbonaceous material and a moisture content in the range of 8% to 15%.

32. The system of claim 31, wherein the incoming feedstock is comprised of mixed solid waste.

33. The system of claim 31, wherein in the incoming feedstock is comprised of woody biomass.

34. The system of claim 31, wherein the mixed solid waste is municipal solid waste (MSW).

35. The system of claim 31, wherein the at least a portion of non-biogenic carbons and non-carbonaceous materials comprises dirt, glass, wet organics, and other inerts.

36. The system of claim 31, wherein the incoming feedstock is processed to selectively recover biogenic carbon material from the incoming feedstock to produce a processed feedstock having high biogenic carbon content suitable for conversion into high biogenic carbon Fischer Tropsch liquids.

37. The system of claim 36, wherein the high biogenic carbon Fischer Tropsch liquids are upgraded to high biogenic carbon liquid fuels.

38. The system of claim 31, wherein the ferrous removal unit comprises magnetic separators.

39. The system of claim 31, further comprising an anaerobic digester station comprising one or more anaerobic digesters, used to digest sewage biosolids, low solids or screened animal manure, and low suspended solids or high soluble solids as in anaerobic filters or upflow sludge blanket digesters.

40. The system of claim 31, wherein the processed feedstock contains up to 50% biogenic carbon content.

41. The system of claim 31, wherein the processed feedstock contains biogenic carbon content in a range of 50% to 100%.

42. The system of claim 31, wherein the processed feedstock contains 51% and greater biogenic carbon content.

43. The system of claim 31, wherein the sorting station comprises a trommel.

44. The system of claim 31, wherein the first comminution unit comprises a shredder with a shredder opening in a range of 6 – 15 inches.

45. The system of claim 31, wherein the fractionation unit comprises a vibratory screen, and where the 2 inch and smaller fraction is removed for further fractionation into an inert low biogenic carbon material and a high biogenic content material.

46. The system of claim 31, wherein the fractionation unit further comprises an air separator wherein a heavy fraction is separated from a light fraction by differences in density.

47. The system of claim 46, wherein the heavy fraction from the air separator is further fractionated in another air separator wherein the heavy fraction is further separated into a medium fraction and a heavy-heavy fraction by differences in density.

48. The system of claim 47, wherein the heavy-heavy fraction is removed as inert low biogenic material.

49. The system of claim 48, wherein the light fraction is combined with the medium fraction and the combined stream is sent to the ferrous removal unit.

50. The system of claim 49, wherein the fine fractionation density unit is configured to fractionate the heavy fraction through a vibratory screen to remove non-carbonaceous (i.e. inert) material having a size of 1 inch and smaller.

51. The system of claim 50, wherein the light fraction, medium fraction and heavy fraction are combined to produce a combined fraction stream and then passed to the non-ferrous removal unit, the non-ferrous removal unit comprising an eddy current configured to remove non-ferrous material.

52. The system of claim 51, wherein the combined fraction stream is passed to the plastic removal unit, the plastic removal unit comprising an optical sorter configured to remove at least a portion of plastic content in the combined fraction stream, to produce a processed feedstock.

53. The system of claim 52, wherein the plastic content in the combined fraction stream is selectively removed such that processed feedstock has a biogenic carbon content of up to 95%.

54. The system of claim 52, wherein the plastic content in the combined fraction stream is selectively removed such that processed feedstock has a biogenic carbon content of up to 50%.

55. The system of claim 52, wherein the plastic content in the combined fraction stream is selectively removed such that processed feedstock has a biogenic carbon content of 51% and greater.

56. The system of claim 52, wherein the plastic content in the combined fraction stream is selectively removed such that processed feedstock has a biogenic carbon content between 50% and to 100%.

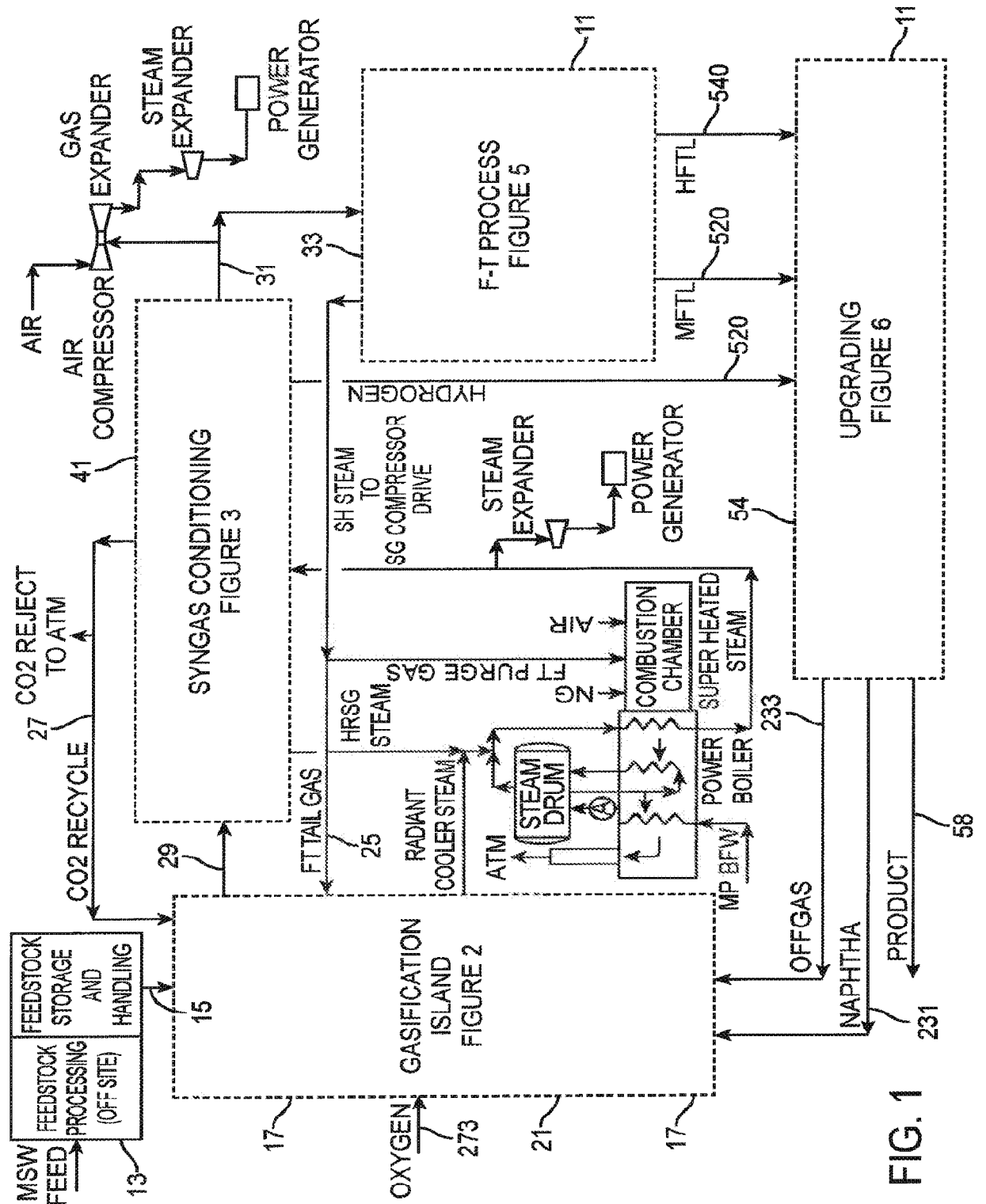

FIG. 1

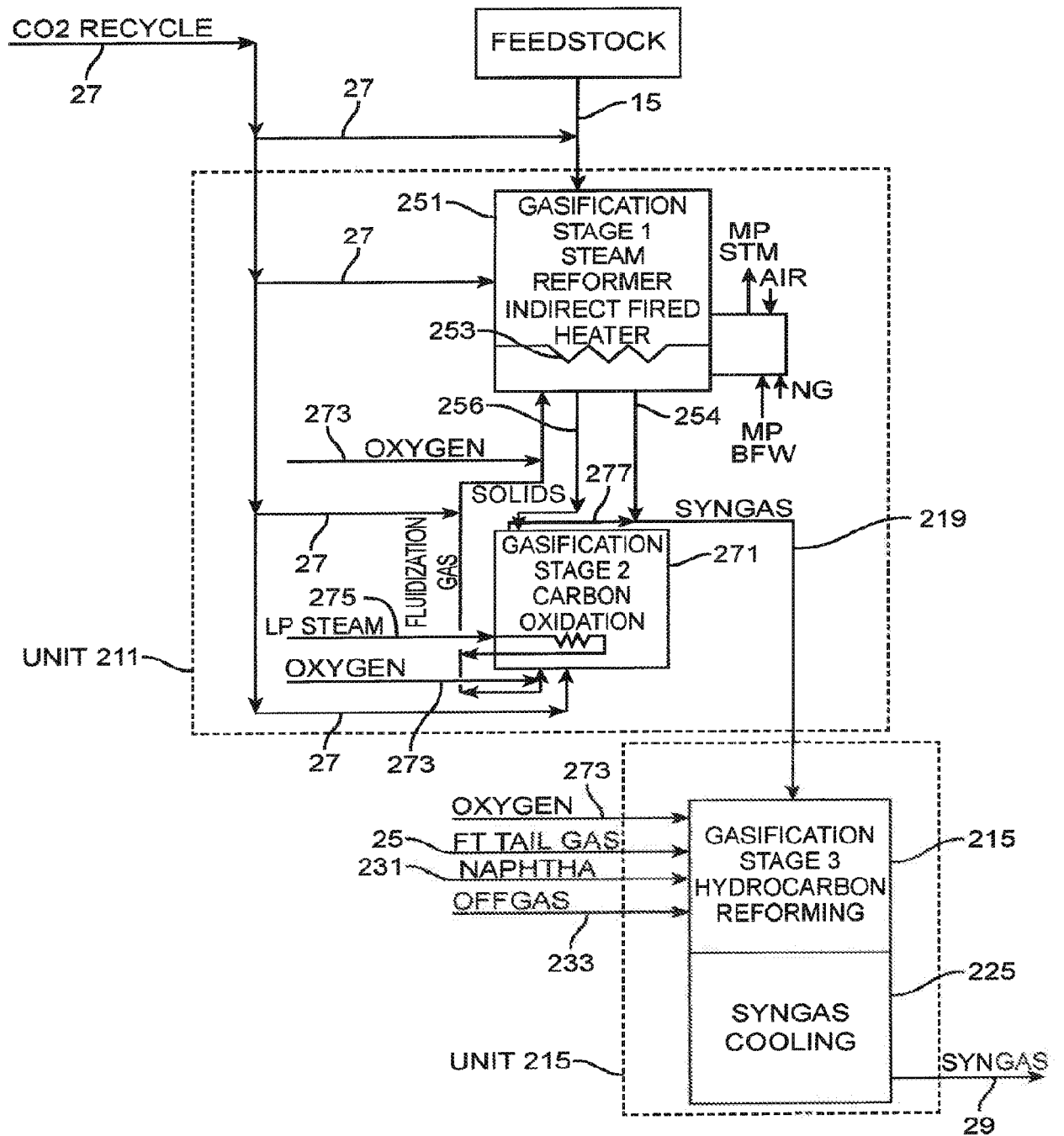

FIG. 2

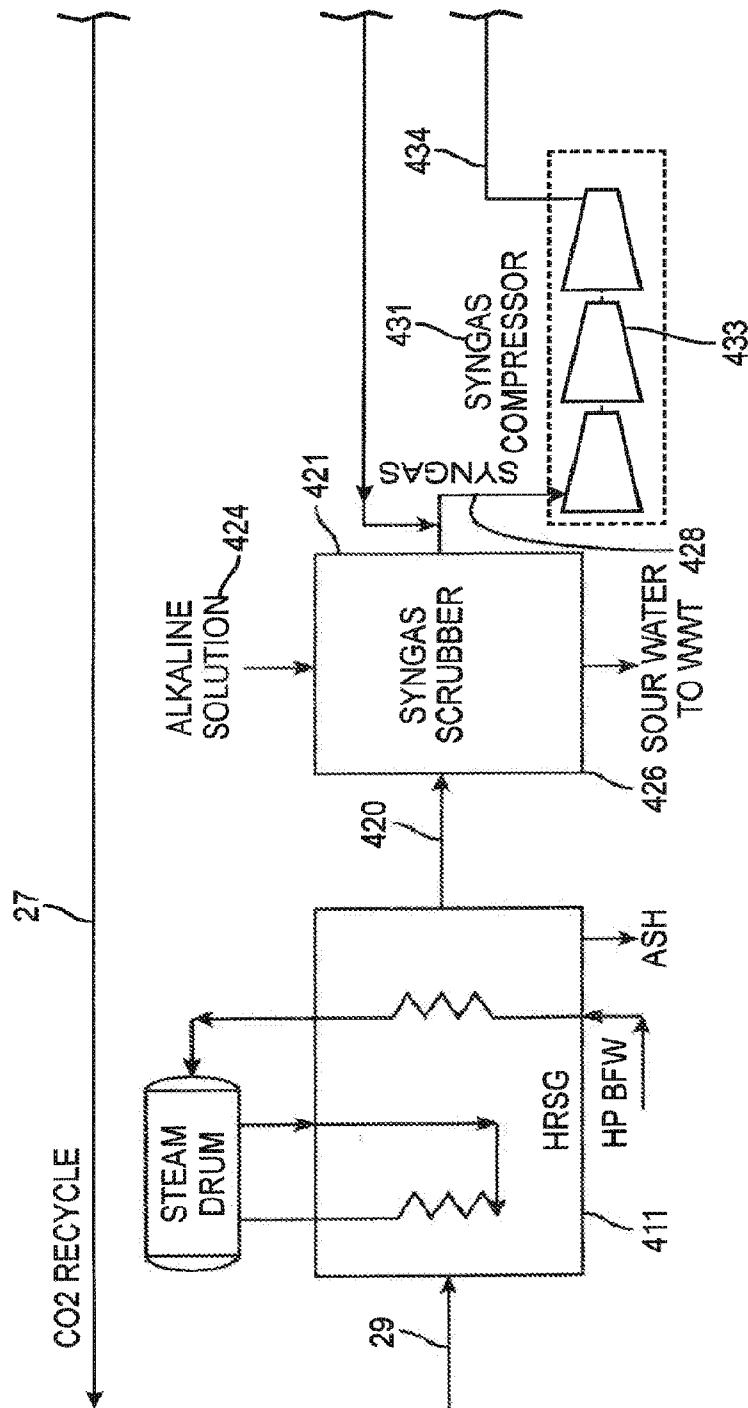

FIG. 3

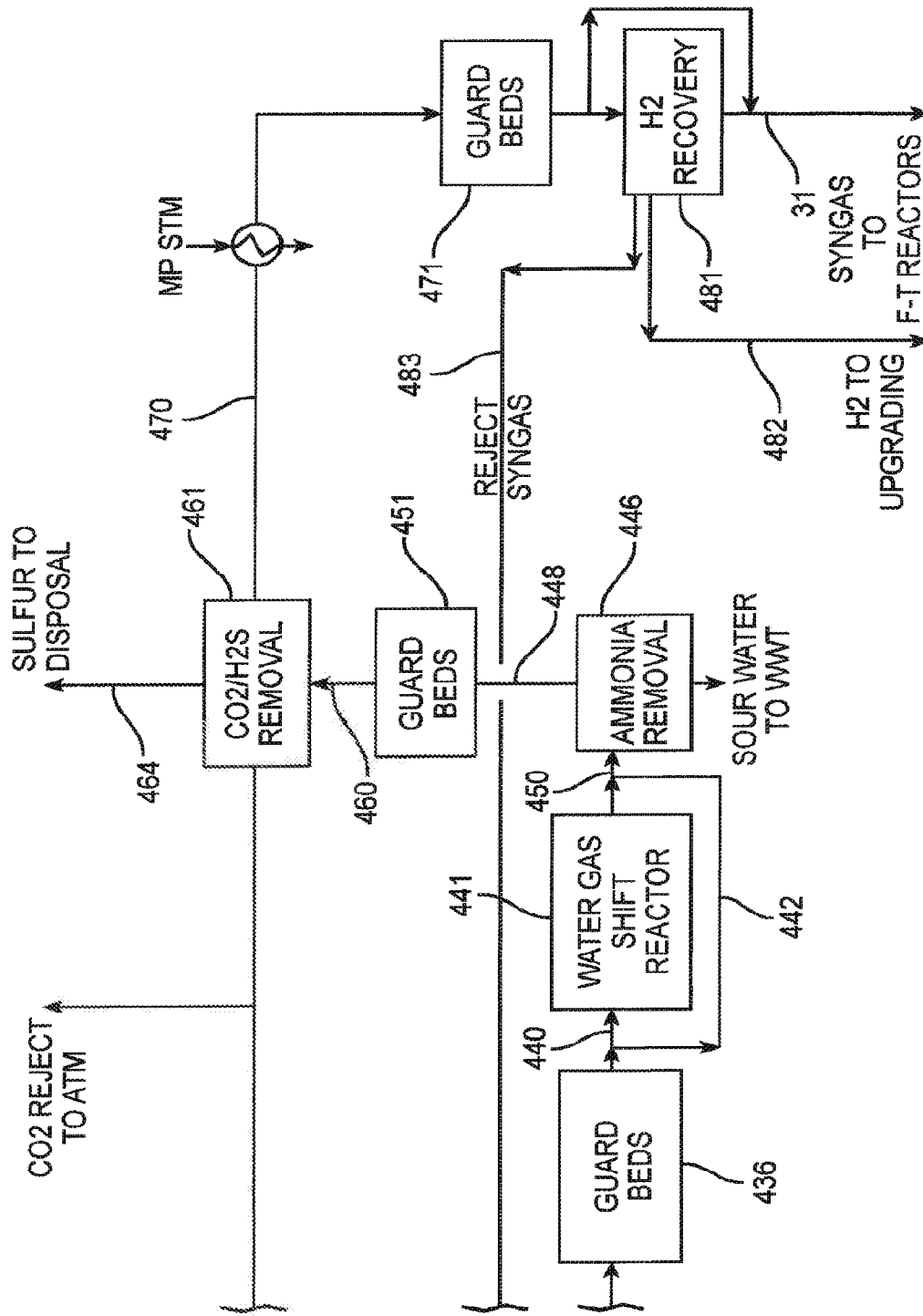

FIG. 3 (Cont.)

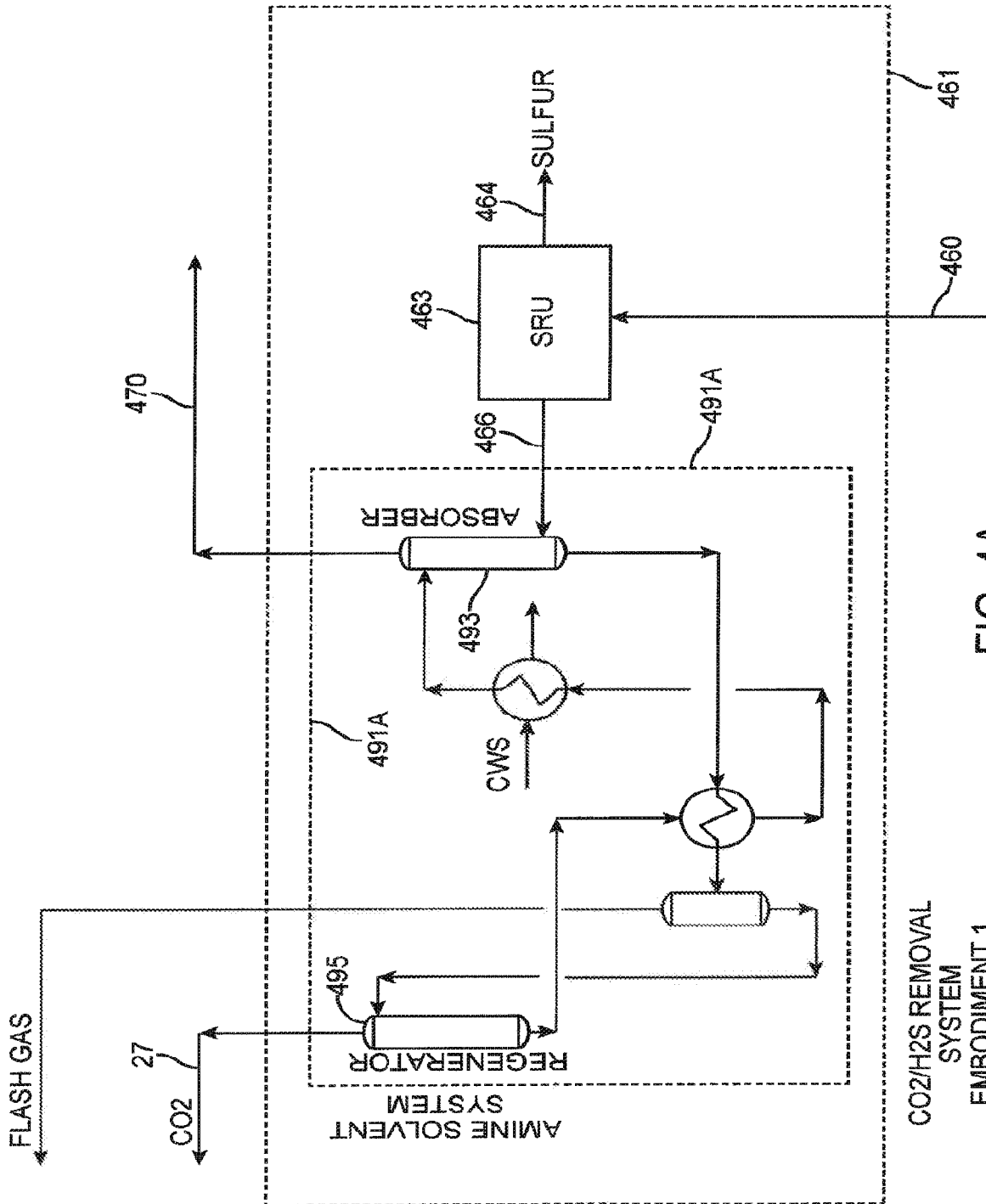
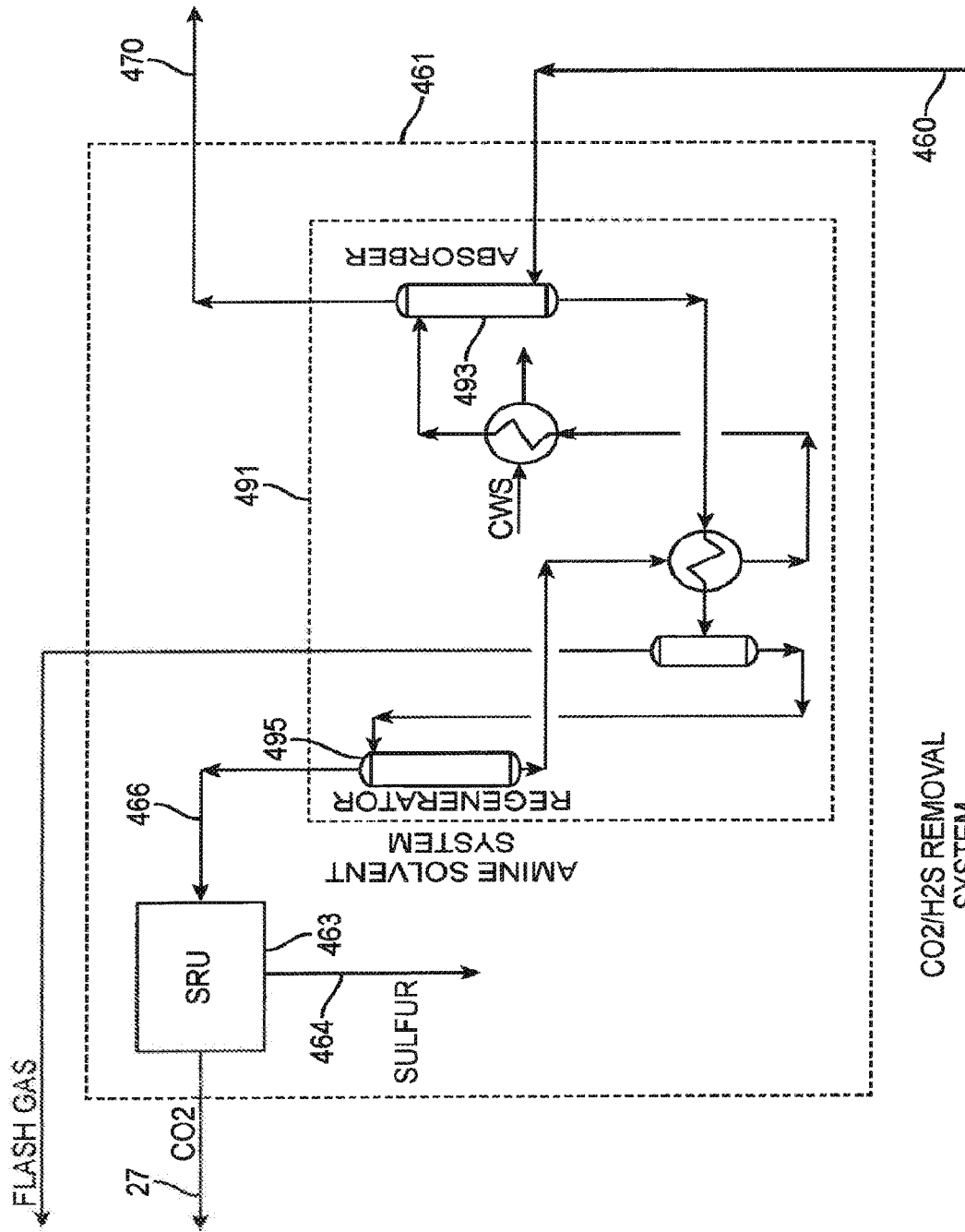

FIG. 4A

CO2/H2S REMOVAL SYSTEM EMBODIMENT 1



CO₂/H₂S REMOVAL SYSTEM EMBODIMENT 2

FIG. 4B

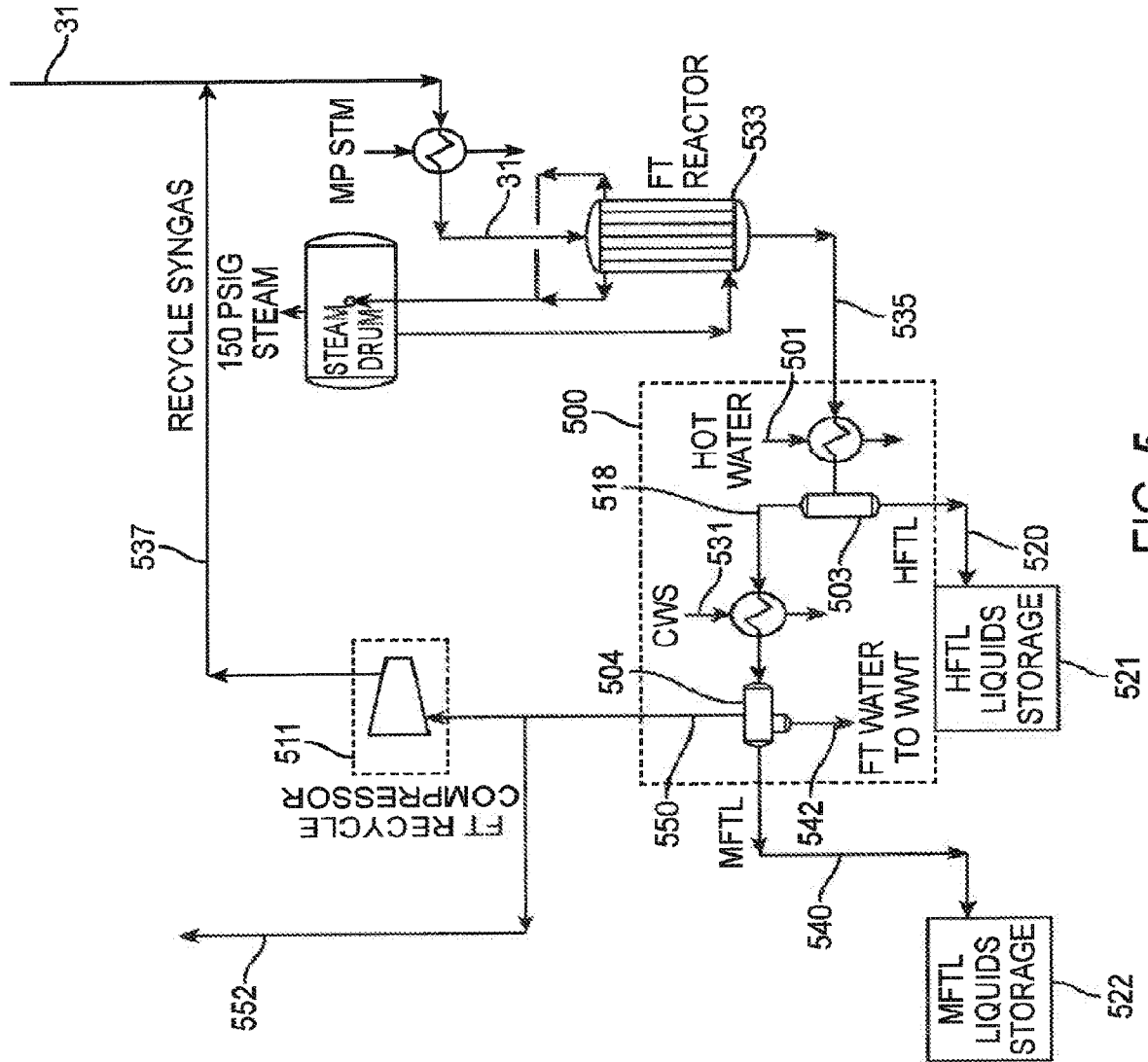

FIG. 5

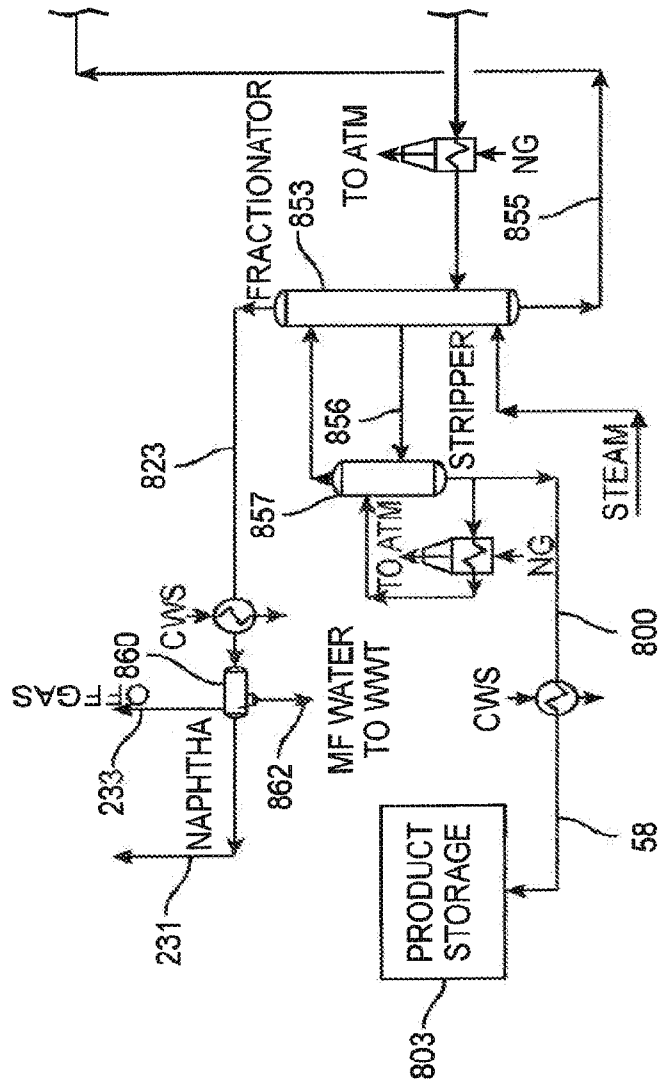

FIG. 6

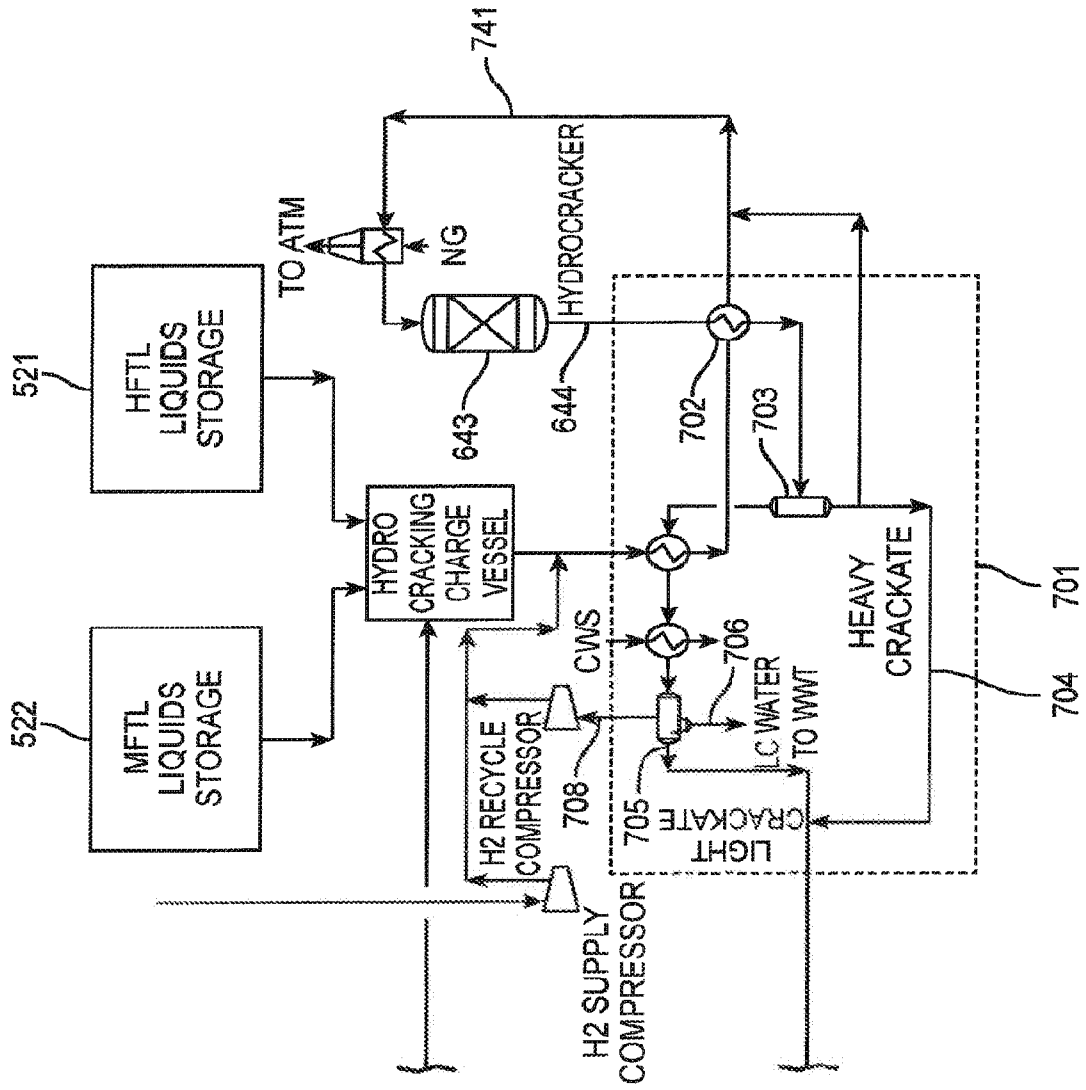

FIG. 6 (Cont.)

Figure 7

1000

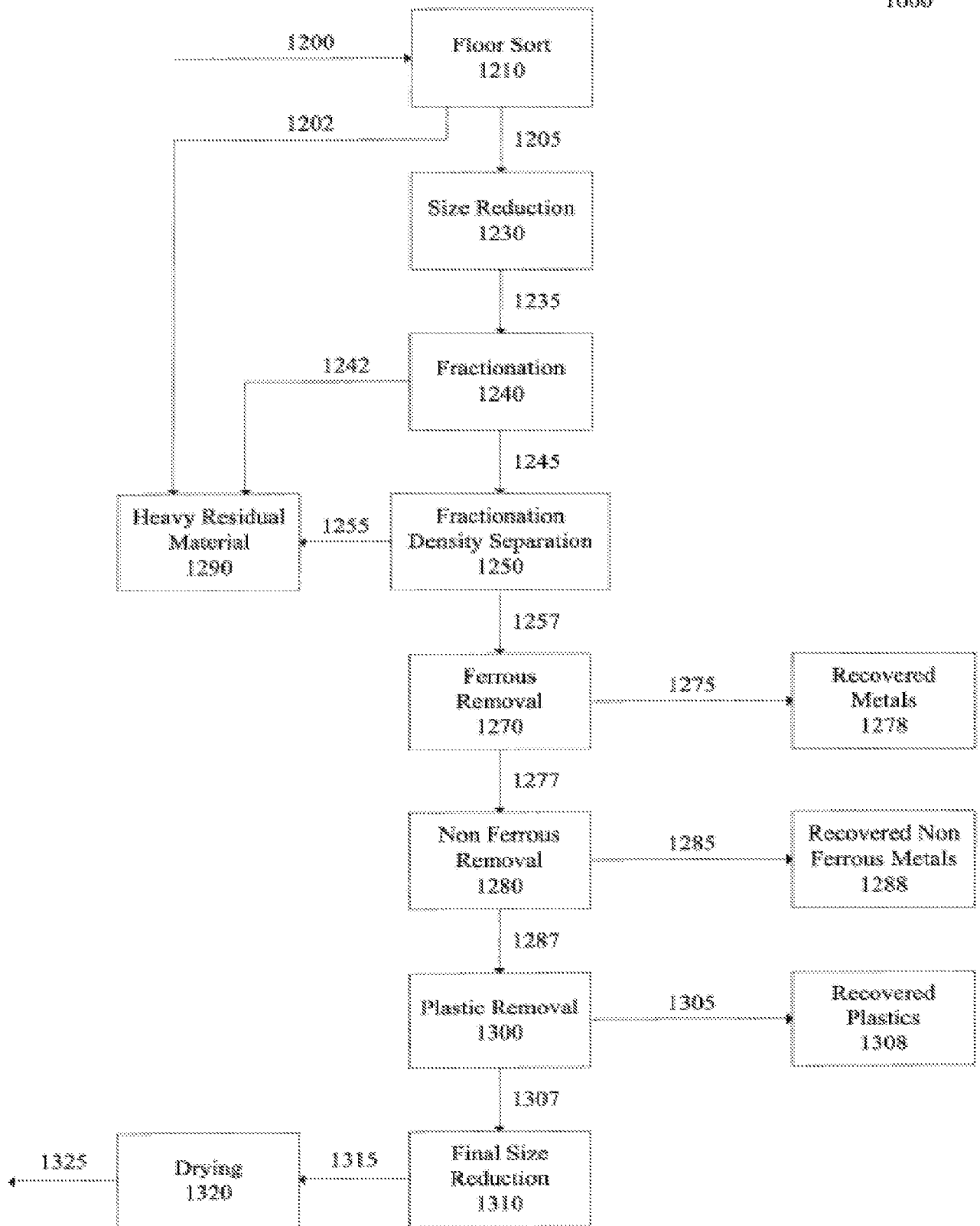

Figure 8

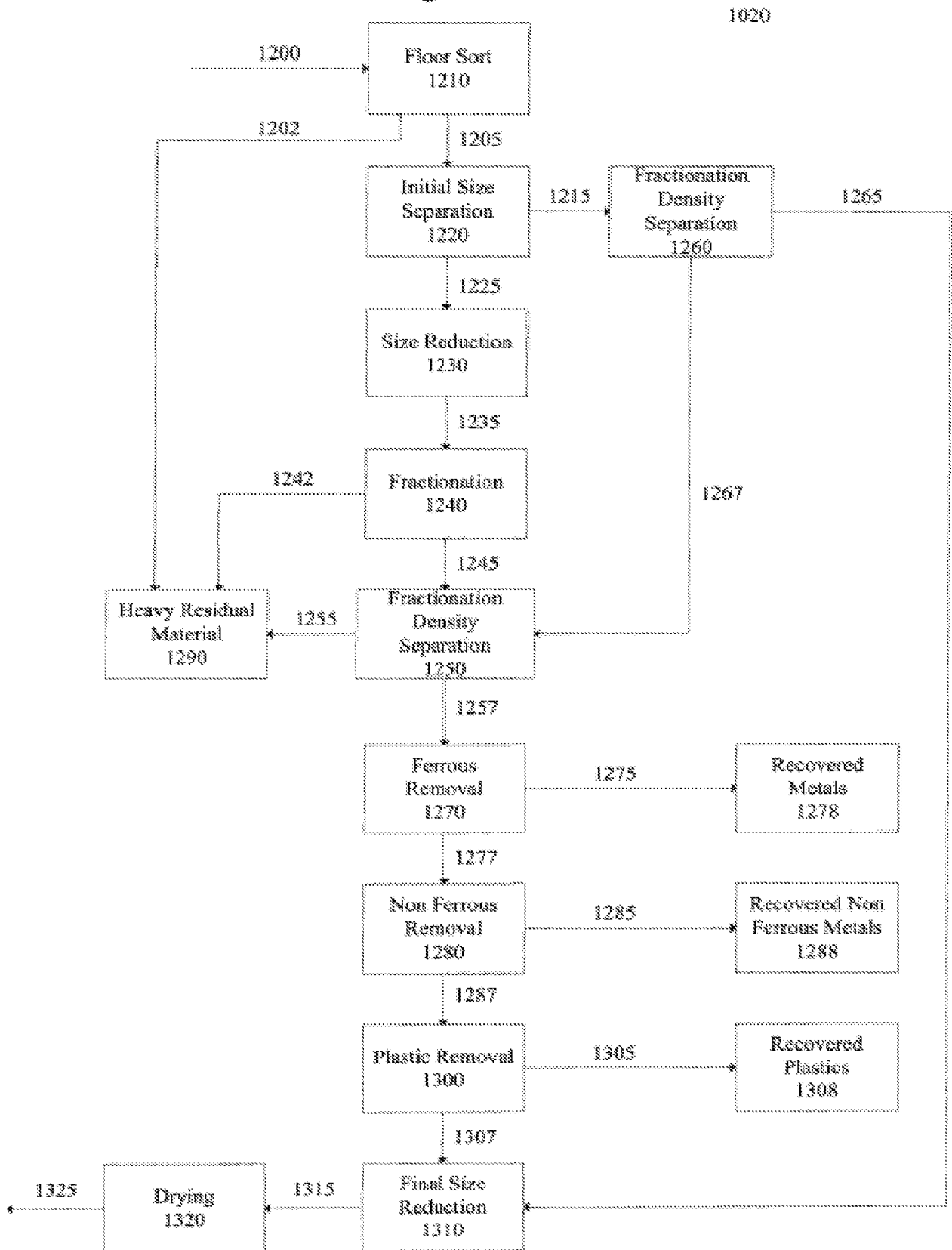

Figure 9

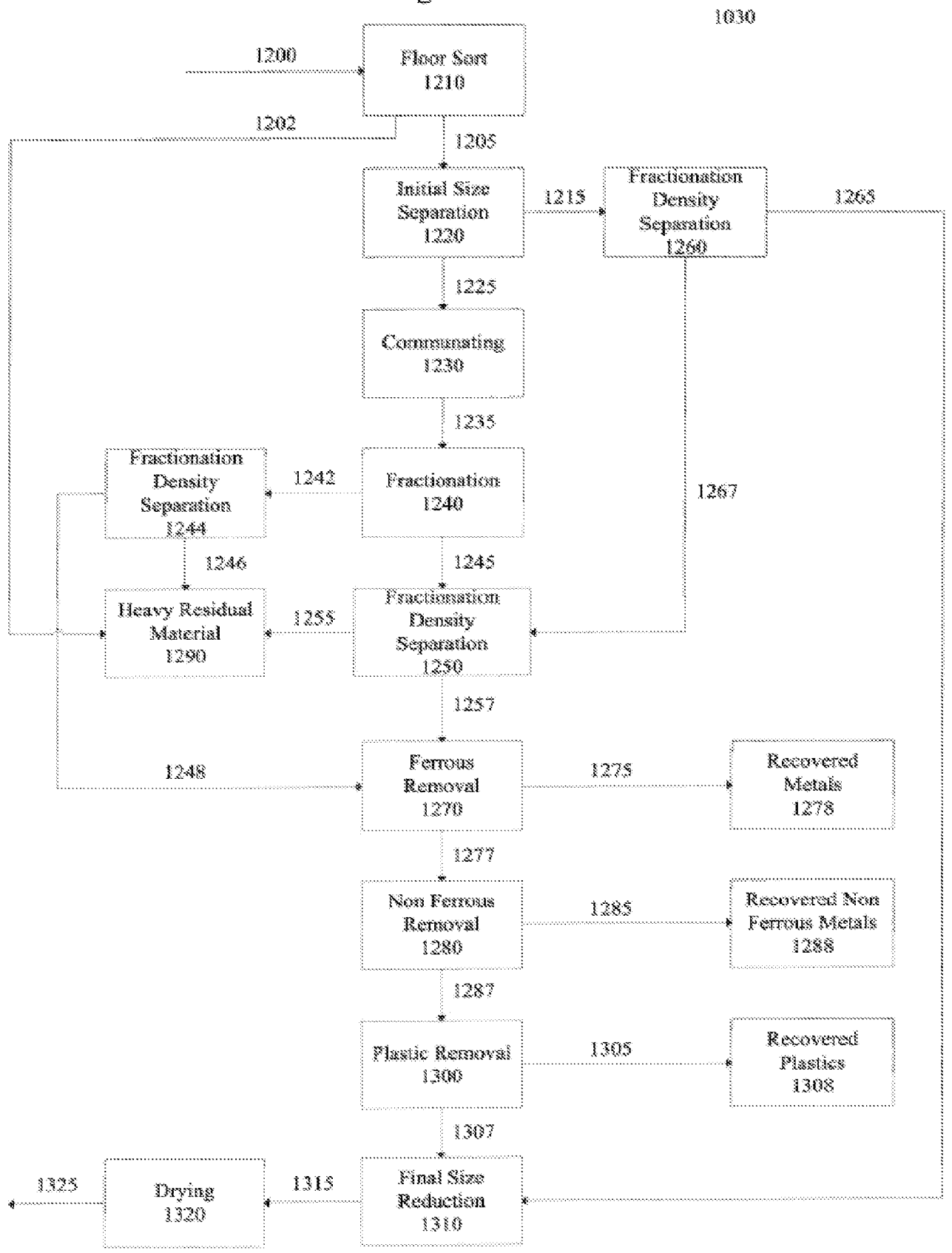

Figure 10

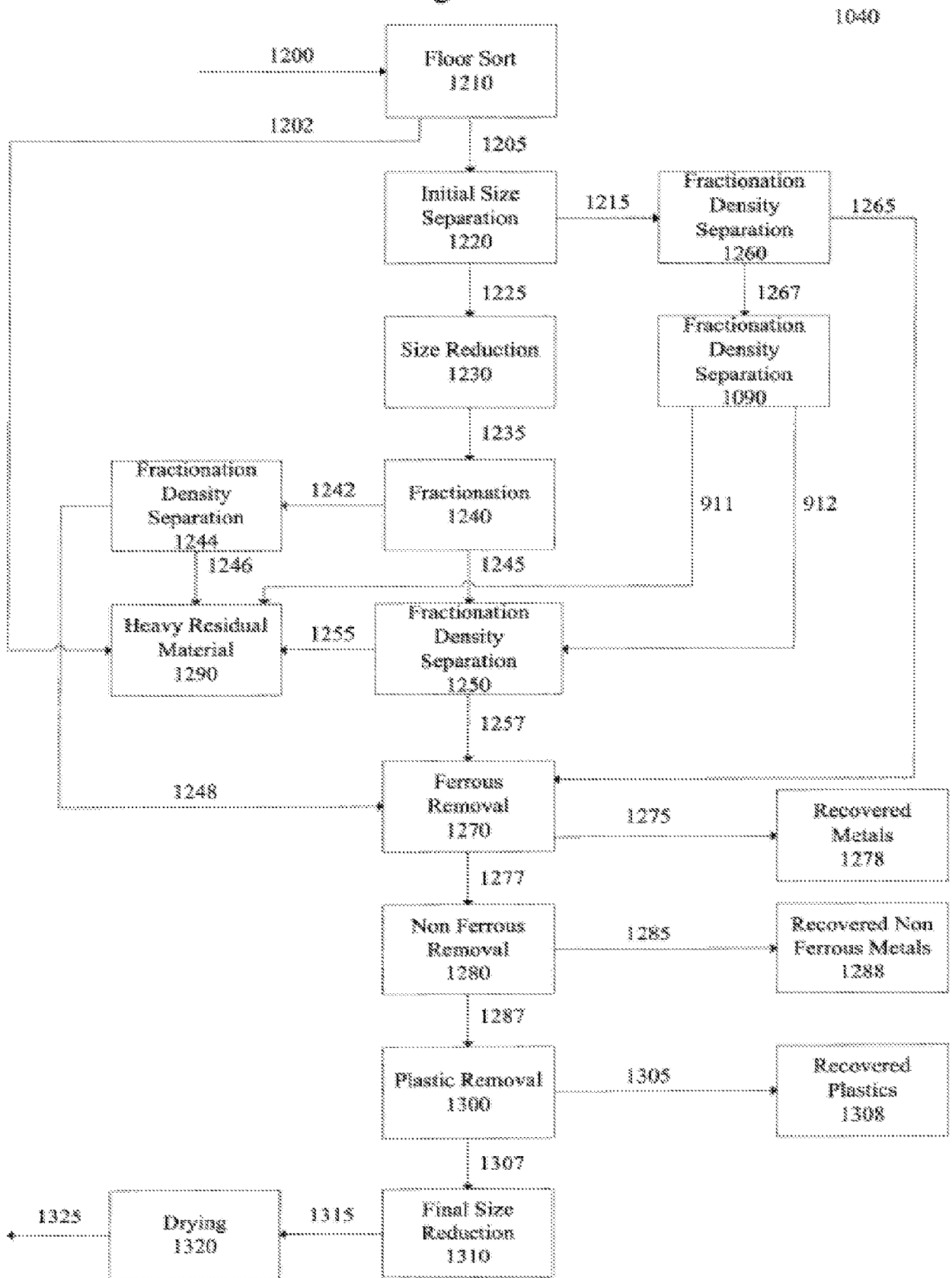

Figure 11

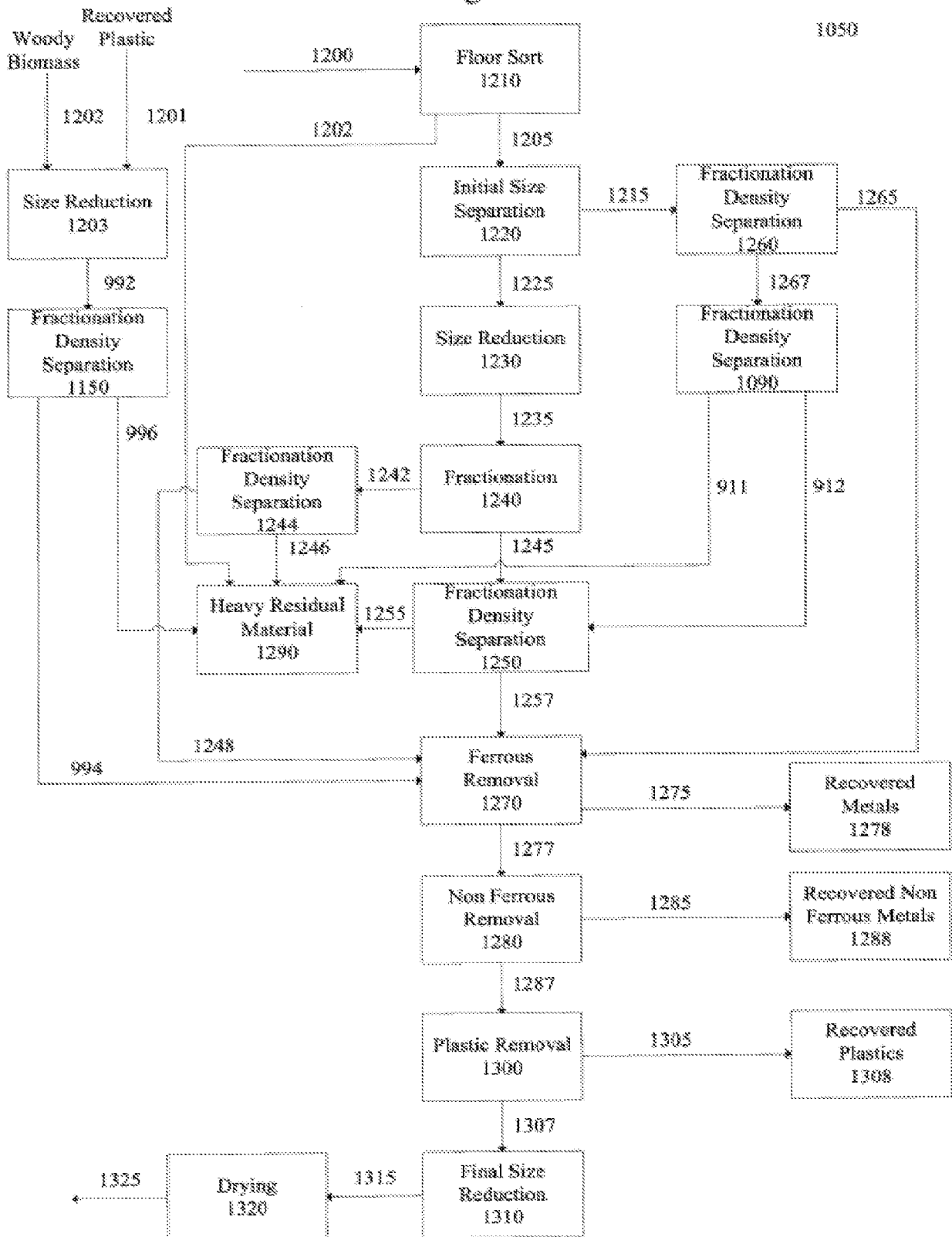

Figure 12

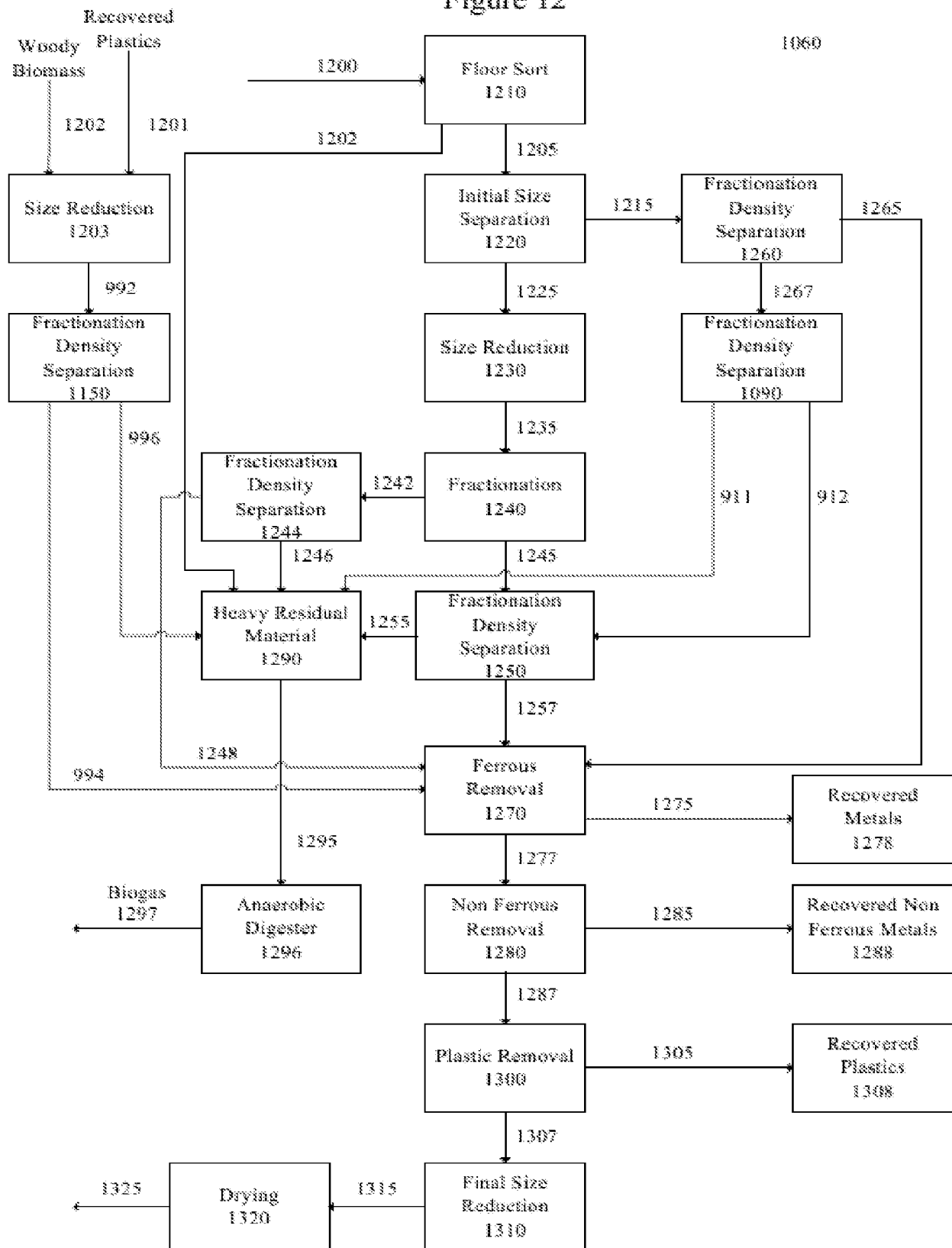

Figure 7

1000

