



US 20170284390A1

(19) **United States**

(12) **Patent Application Publication**

Noda et al.

(10) **Pub. No.: US 2017/0284390 A1**

(43) **Pub. Date: Oct. 5, 2017**

(54) **HEATING/COOLING SYSTEM FOR
INDWELLING HEAT EXCHANGE
CATHETER**

uation-in-part of application No. 09/965,560, filed on
Sep. 25, 2001, now Pat. No. 6,581,403.

Publication Classification

(71) Applicant: **Zoll Circulation, Inc.**, Jan Jose, CA
(US)

(51) **Int. Cl.**
F04C 2/18 (2006.01)
F04C 15/00 (2006.01)

(72) Inventors: **Wayne A. Noda**, Mission Viejo, CA
(US); **Stelica Stelea**, Yorba Linda, CA
(US)

(52) **U.S. Cl.**
CPC *F04C 2/18* (2013.01); *F04C 15/0069*
(2013.01); *F25D 17/02* (2013.01)

(21) Appl. No.: **15/490,643**

(57) **ABSTRACT**

(22) Filed: **Apr. 18, 2017**

Related U.S. Application Data

(60) Continuation of application No. 13/659,123, filed on
Oct. 24, 2012, now Pat. No. 9,624,926, which is a
continuation of application No. 11/765,564, filed on
Jun. 20, 2007, now Pat. No. 8,317,491, which is a
division of application No. 10/913,127, filed on Aug.
6, 2004, now Pat. No. 7,287,398, which is a contin-

A cooling system for an indwelling heat exchange catheter includes a heat exchange bath that is configured to receive a conduit that carries saline to and from the catheter. A heating/cooling fluid is in the bath and exchanges heat with the saline. The heating/cooling fluid flows through a heat exchanger that includes a refrigerant and two variable speed DC compressor for removing heat from the refrigerant. A gear pump circulates the working fluid to and from the catheter and is removably engaged with a pump support platform.

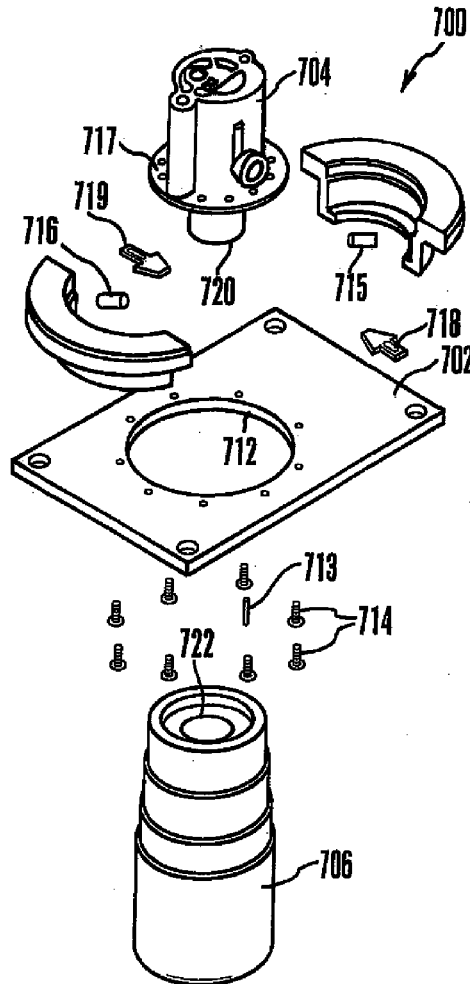

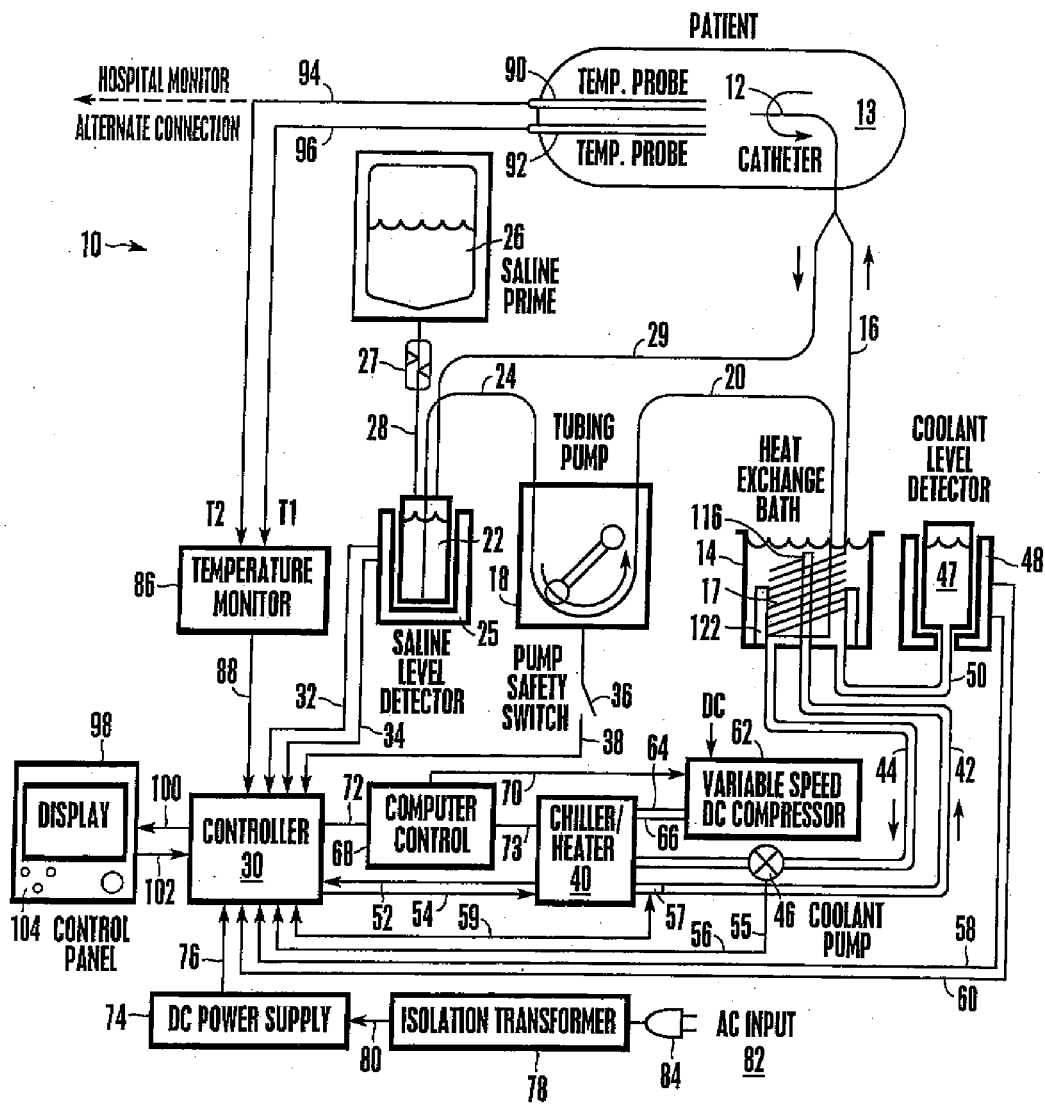

Fig. 1

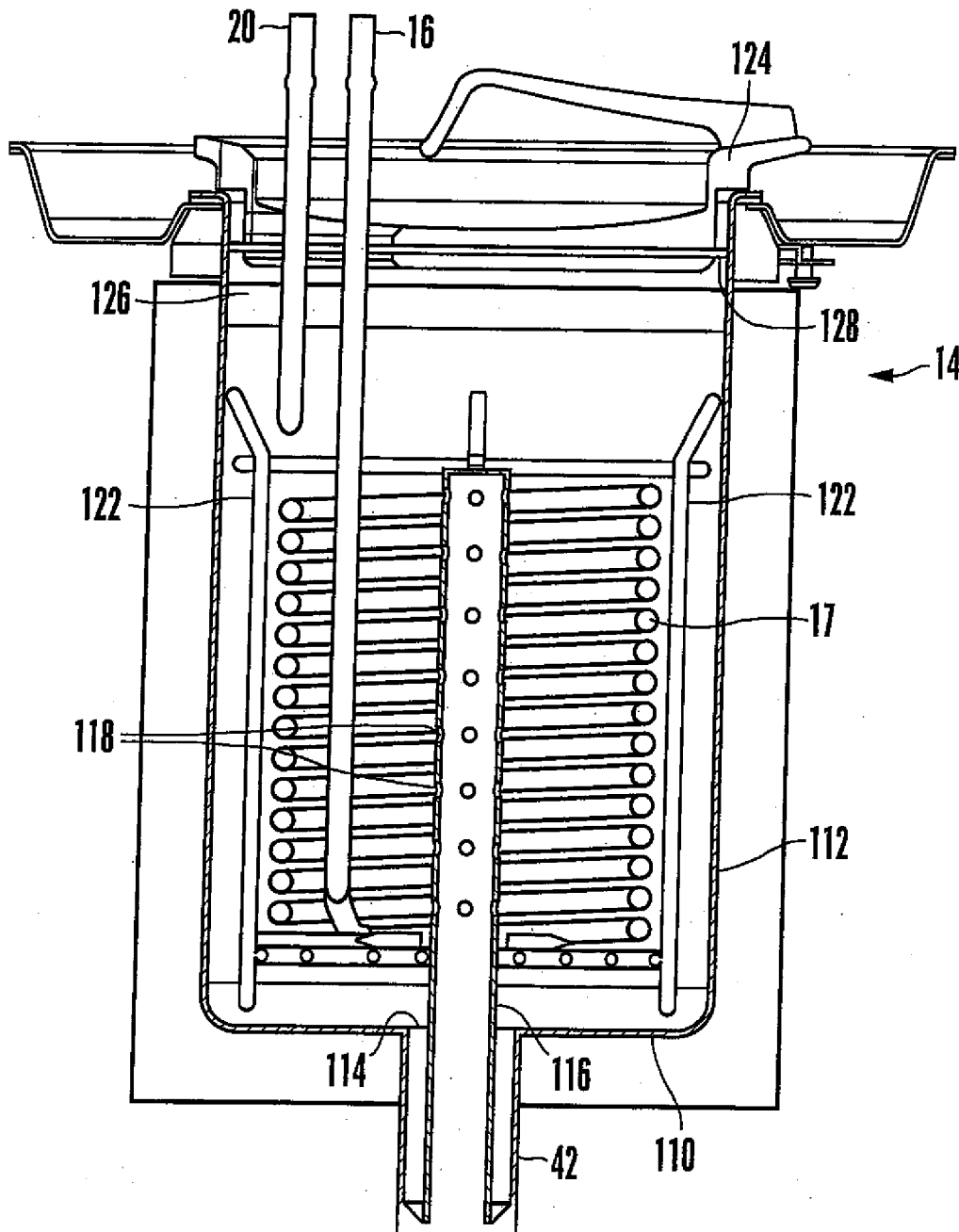

Figure 2

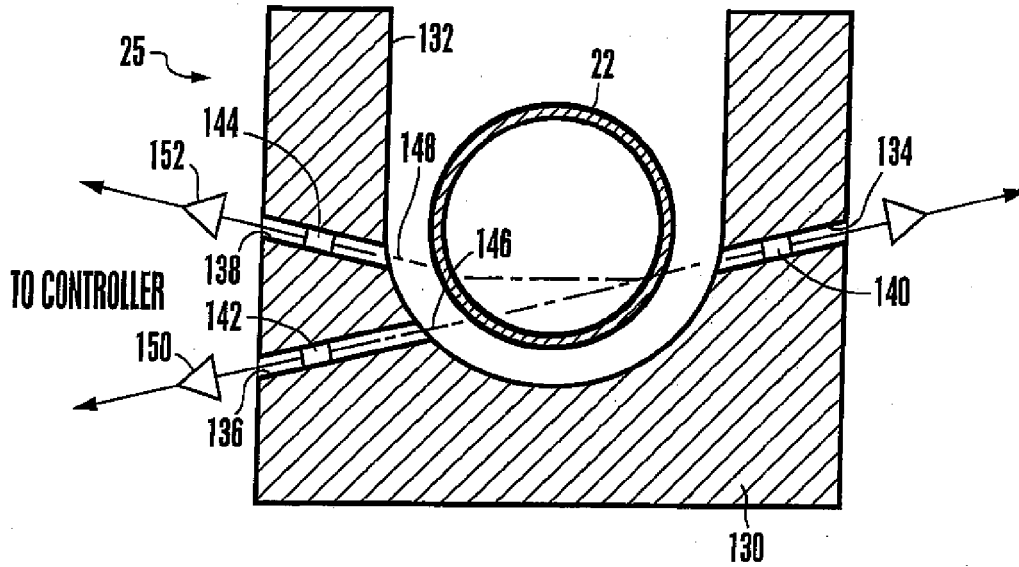

Figure 3

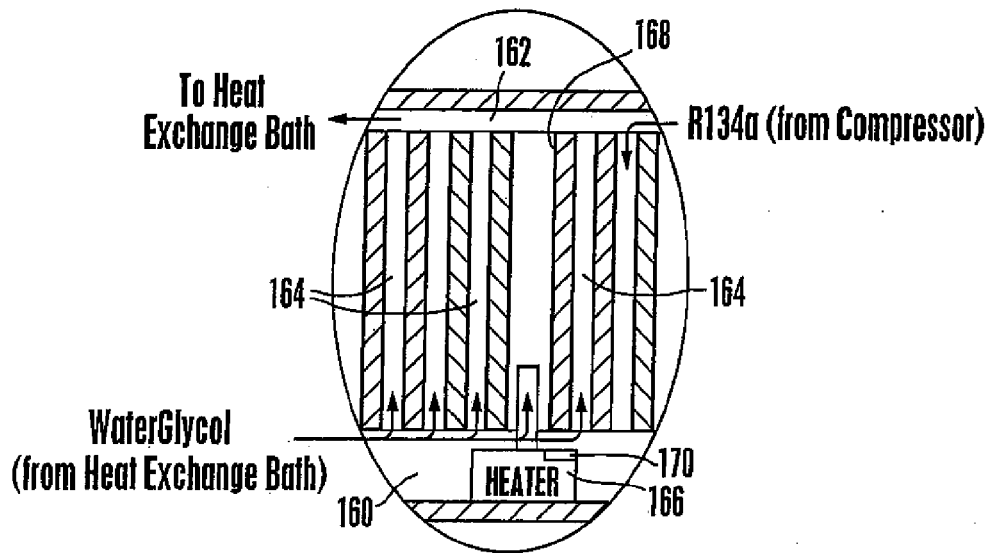

Figure 4

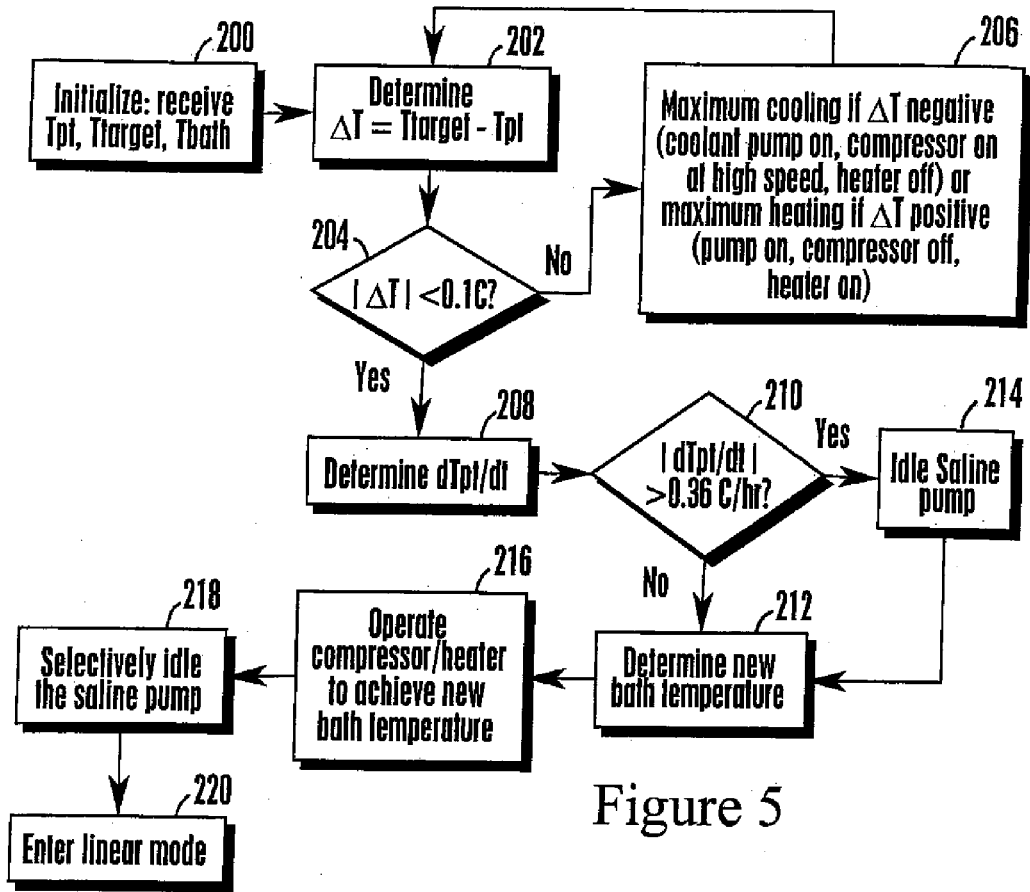

Figure 5

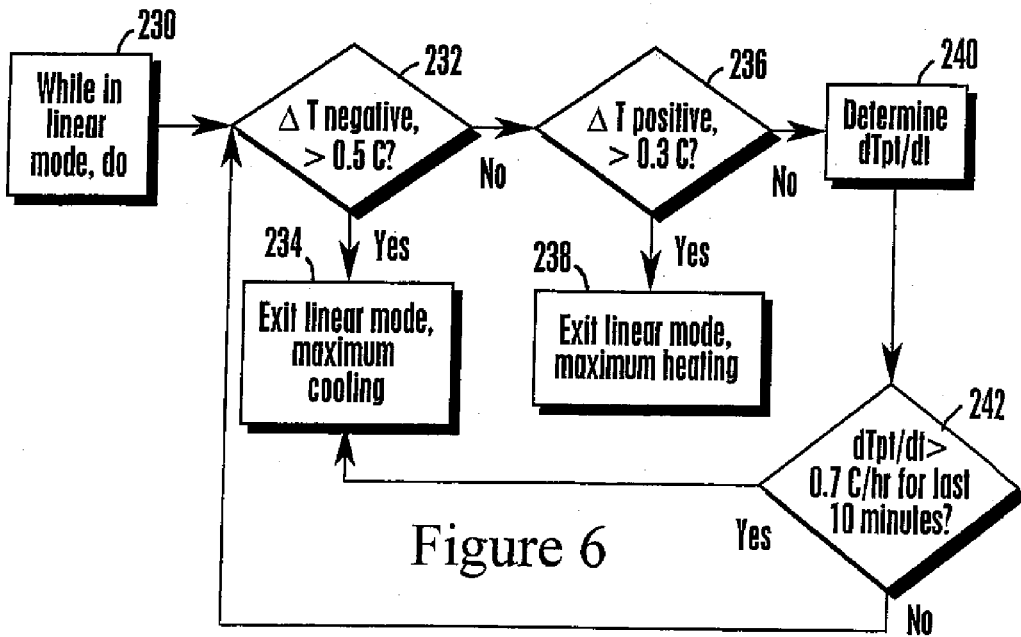

Figure 6

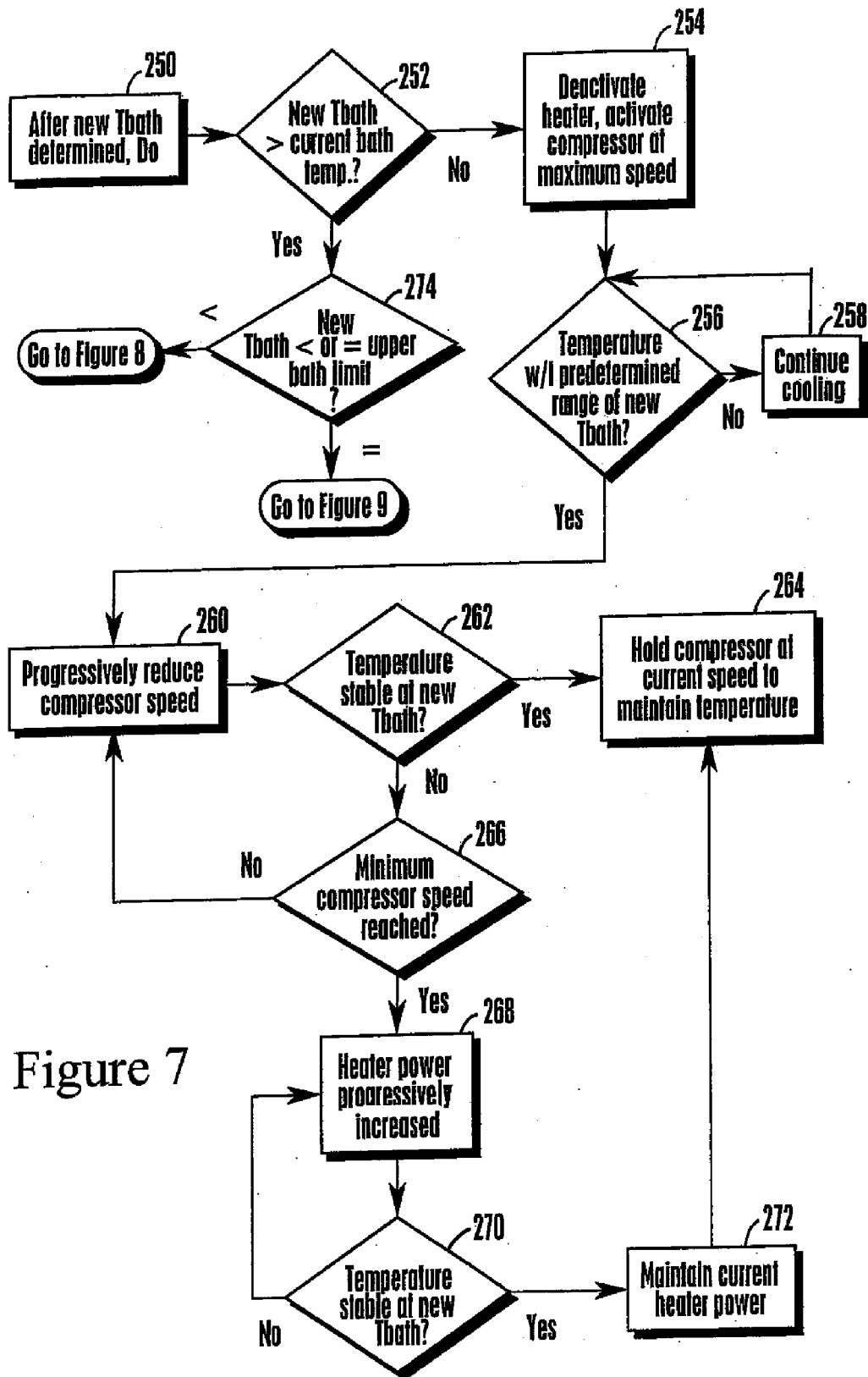

Figure 7

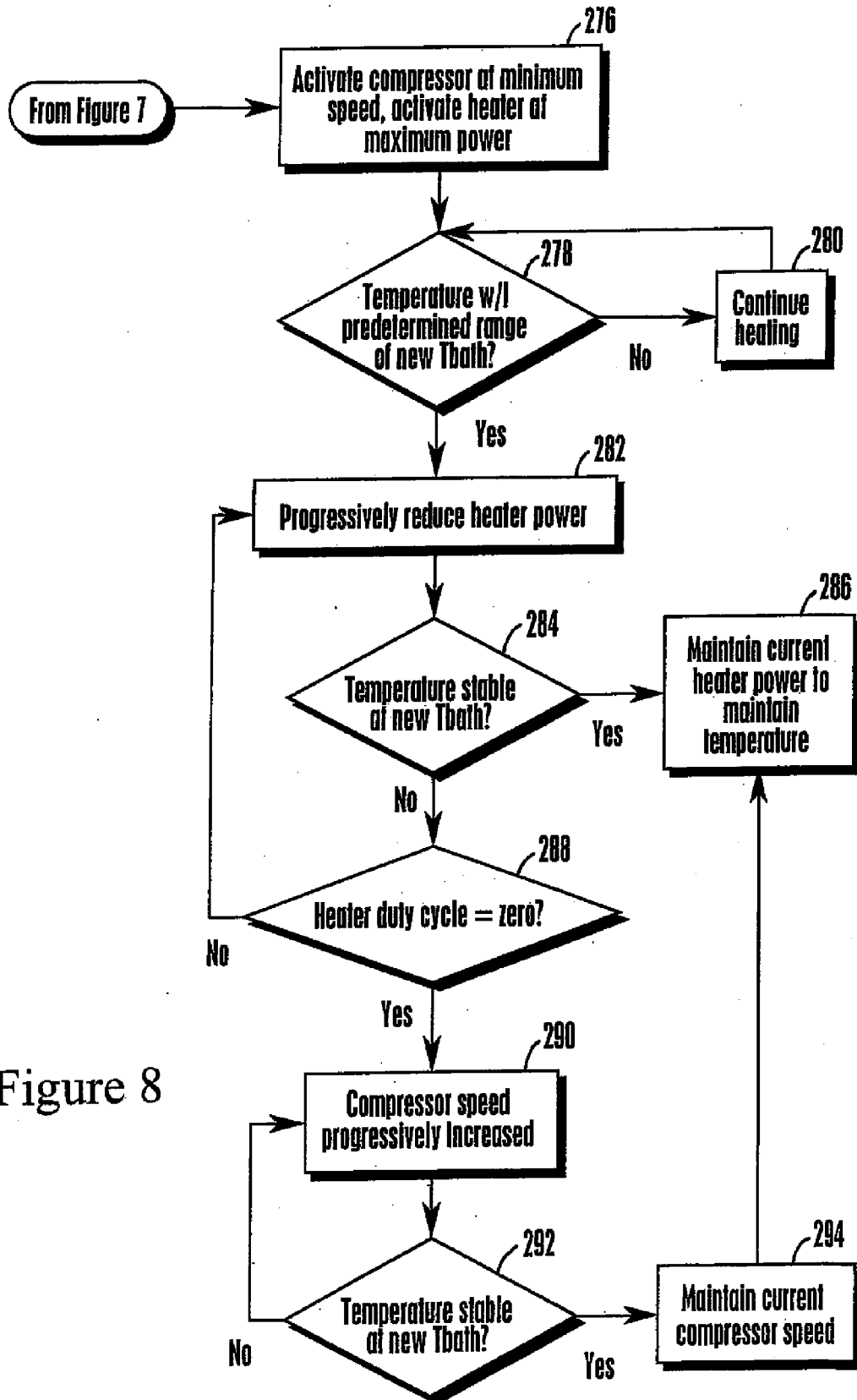

Figure 8

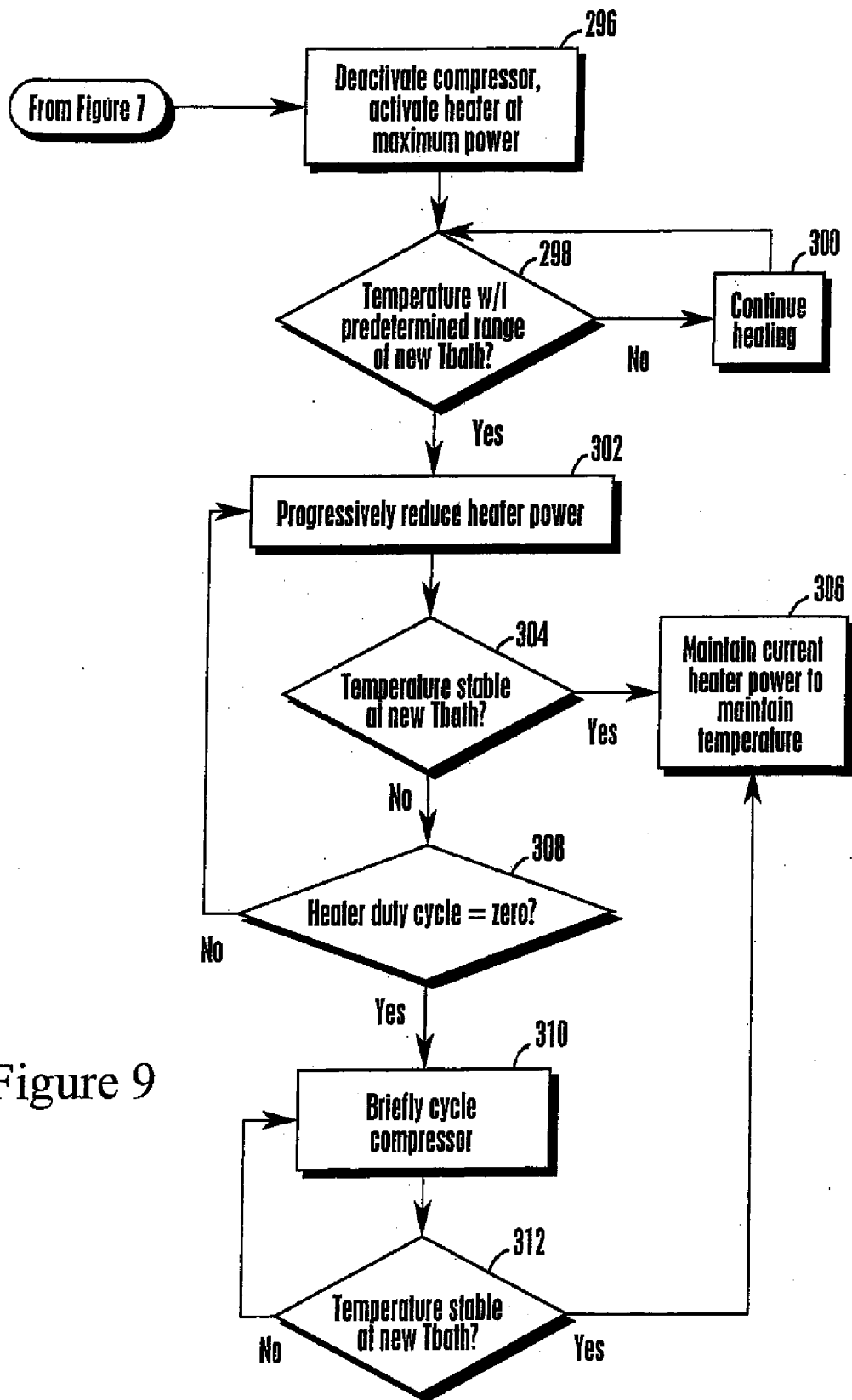
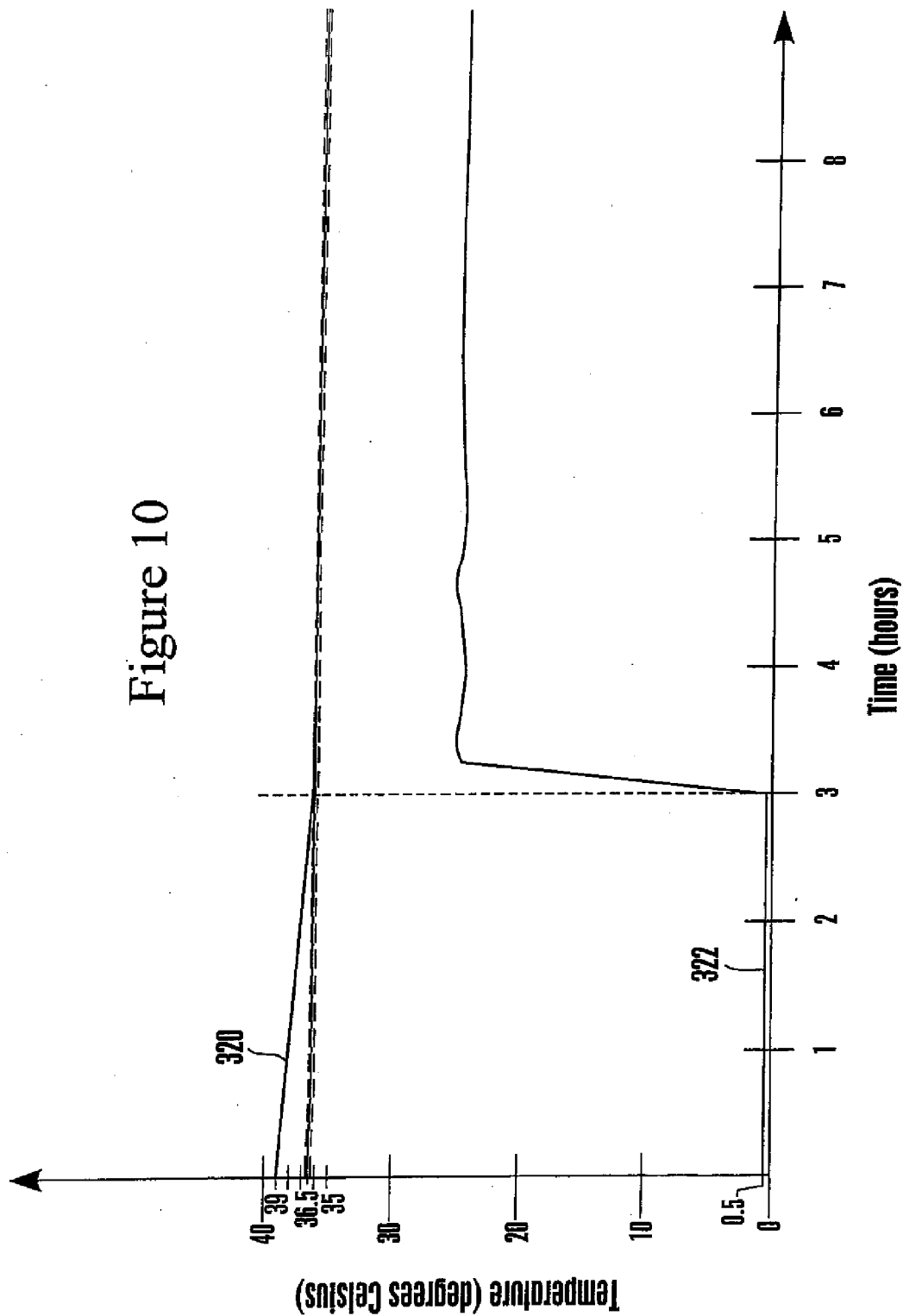

Figure 9

Figure 10



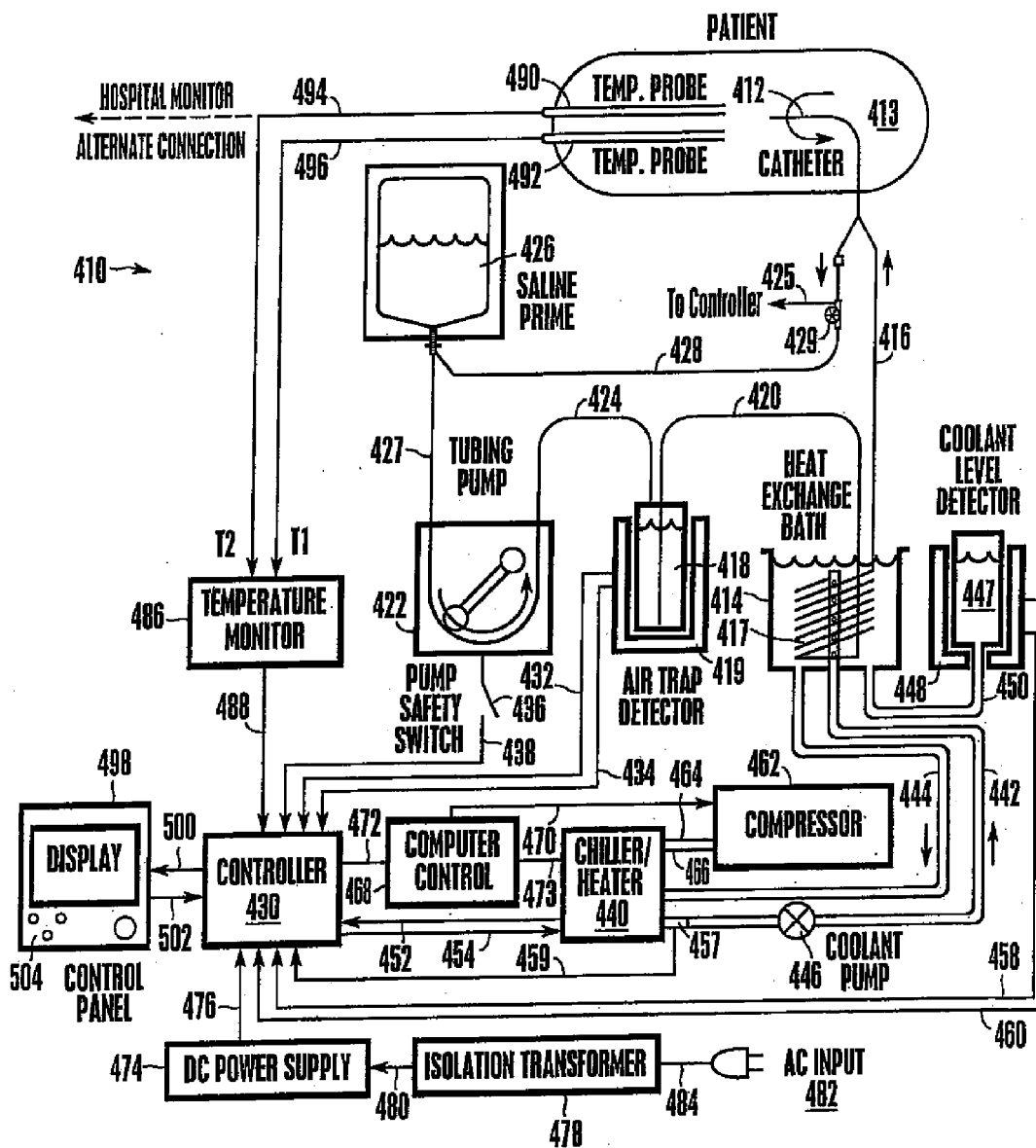

Figure 11

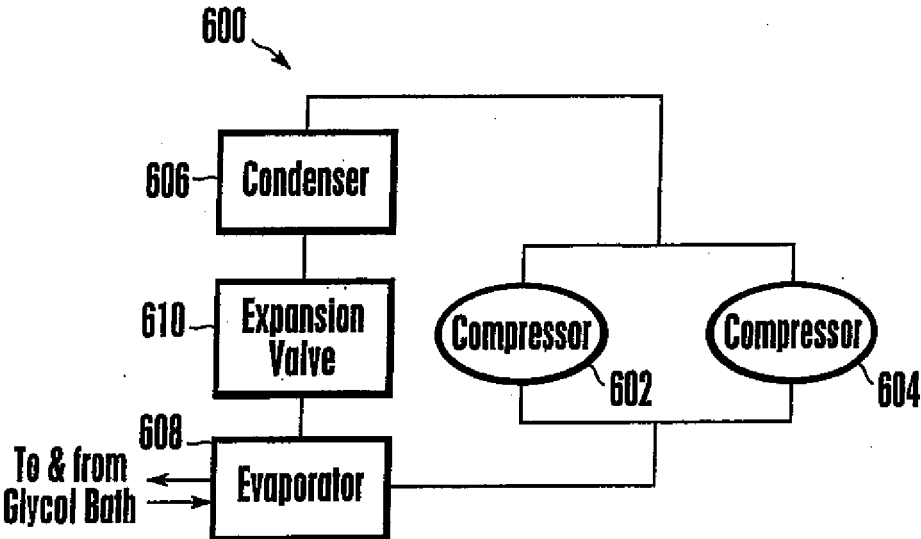

Figure 12

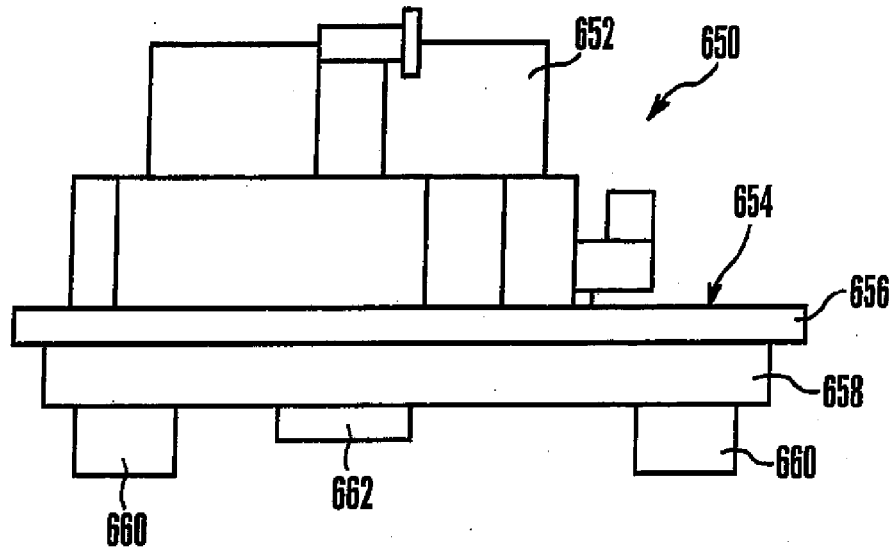

Figure 13

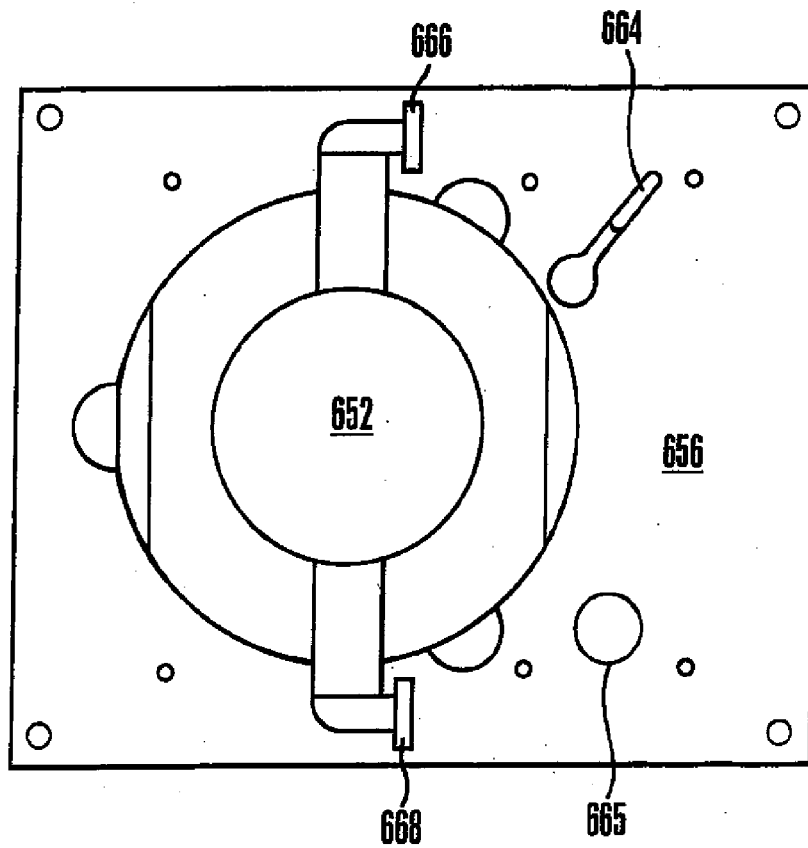

Figure 14

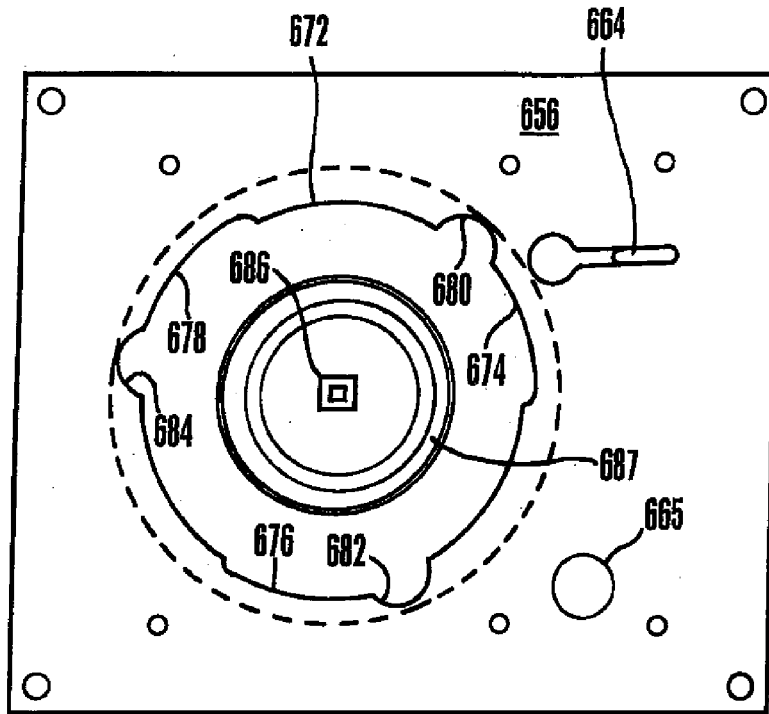

Figure 15

654

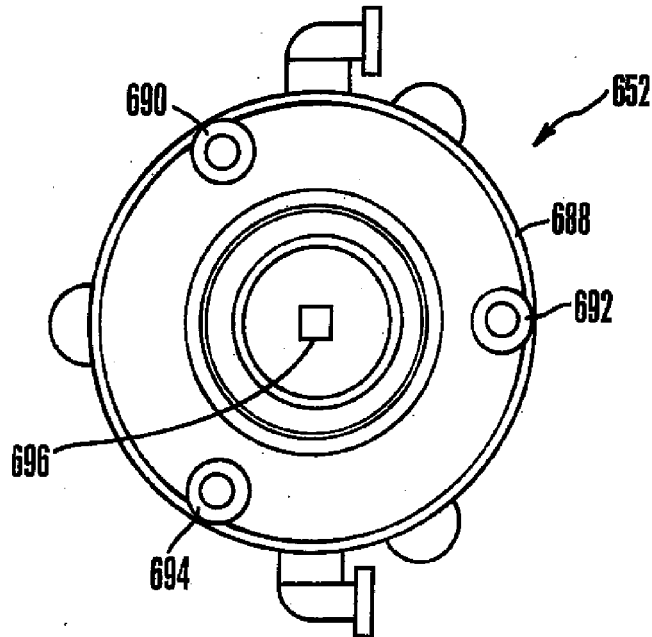

Figure 16

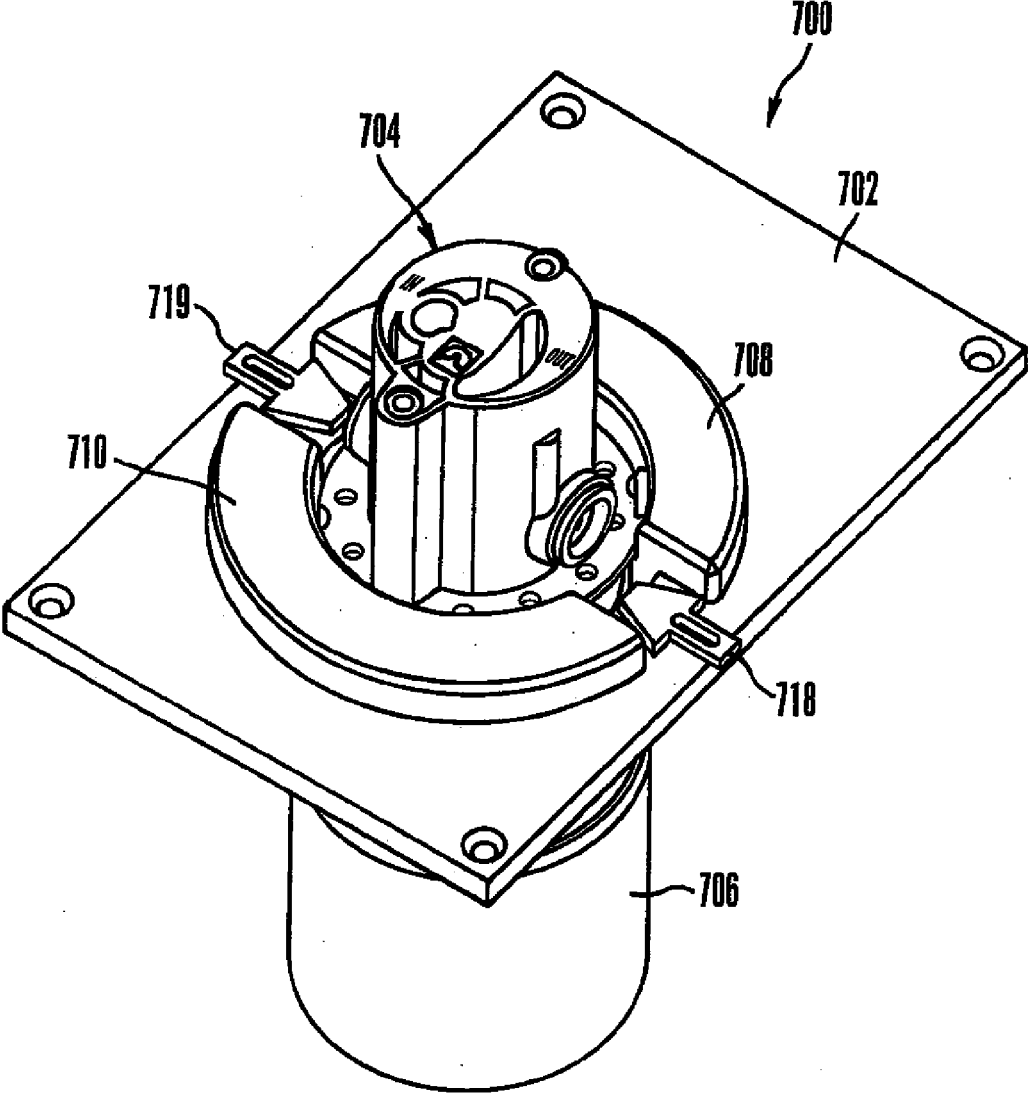

Figure 17

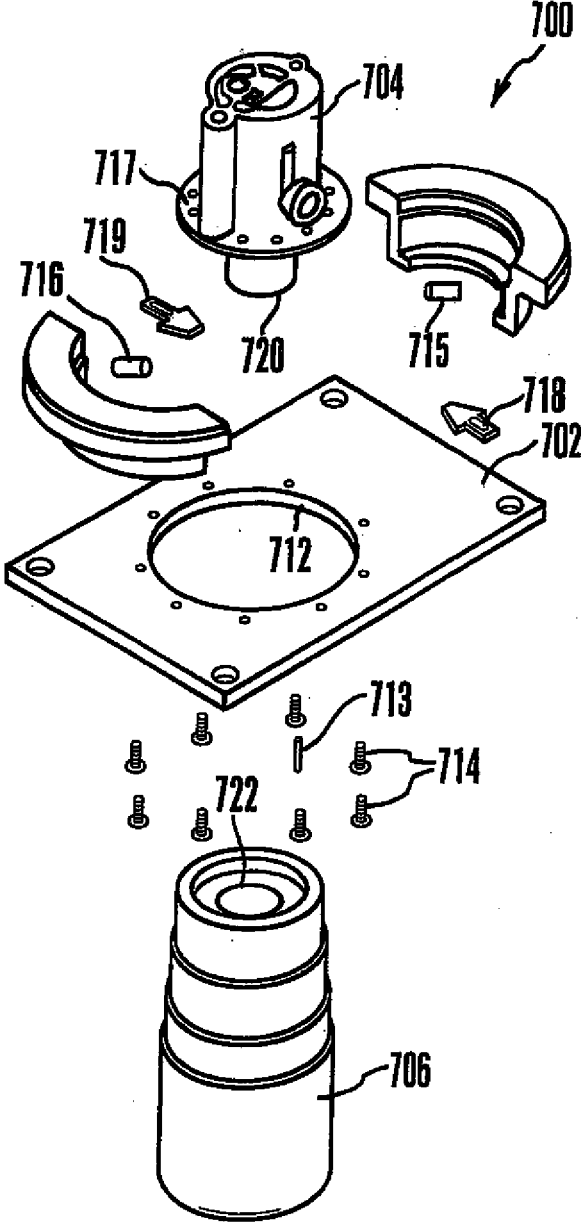

Figure 18

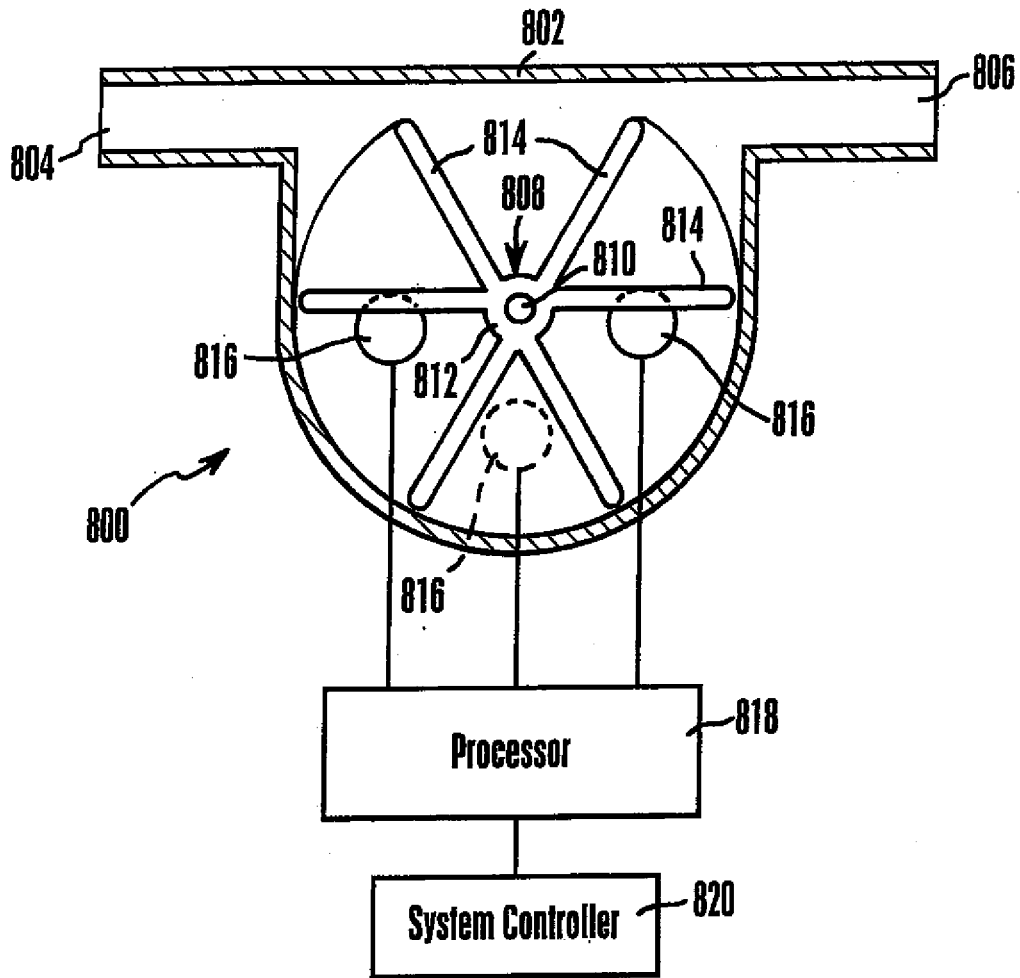
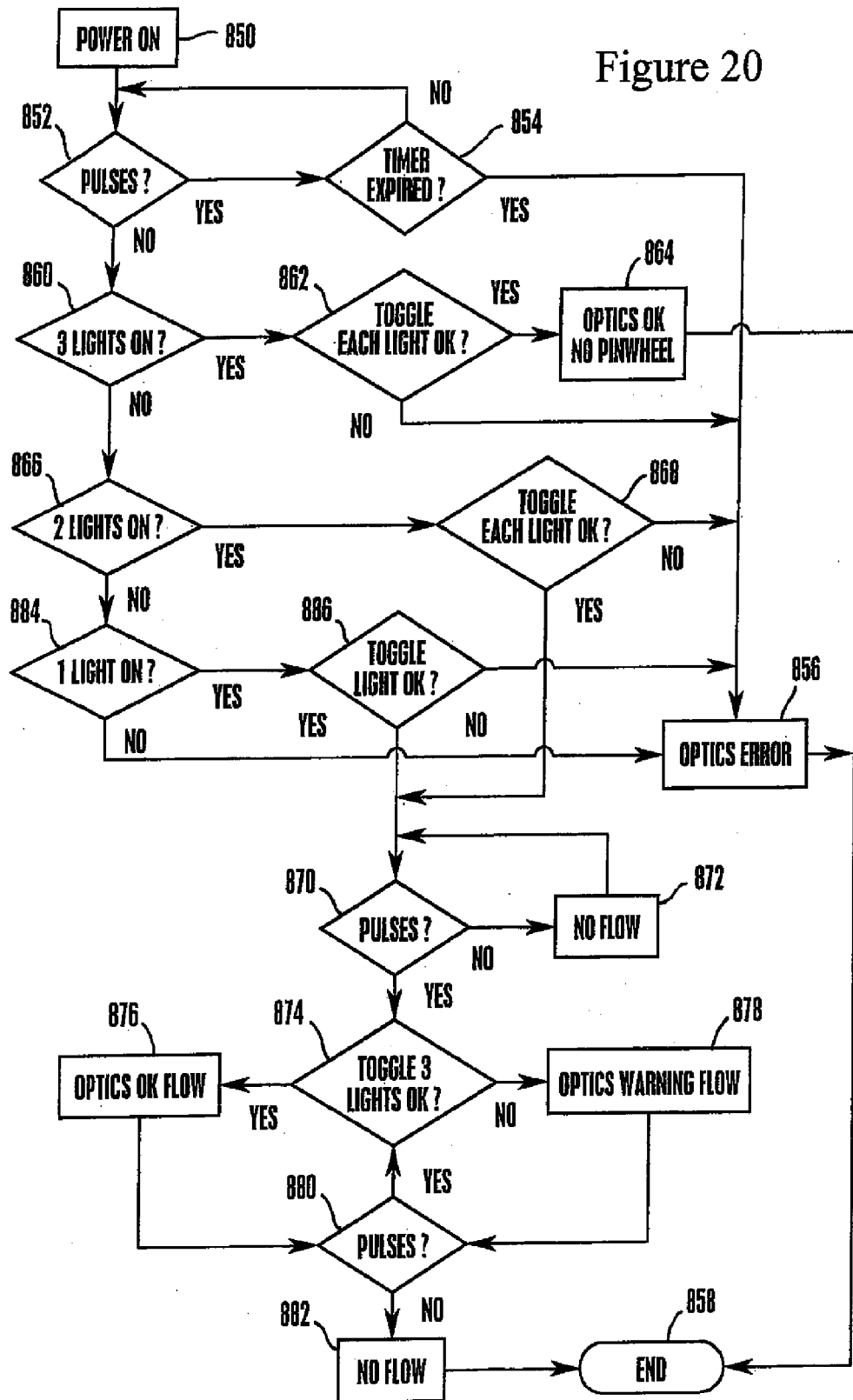

Figure 19

Figure 20



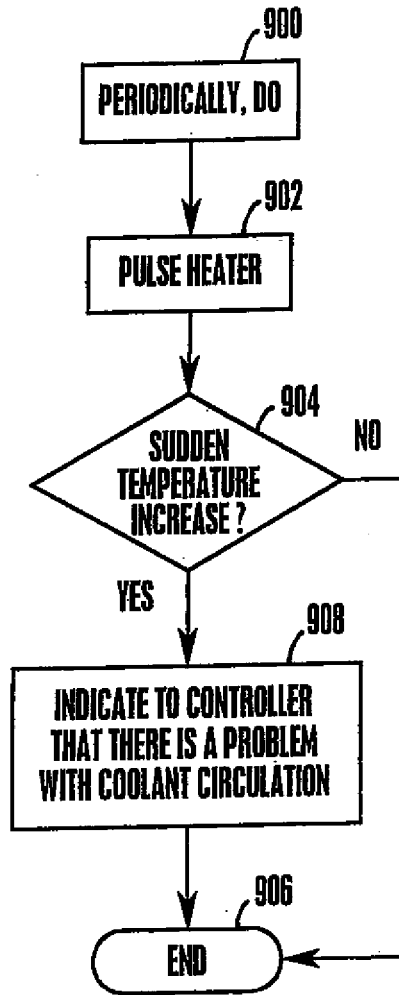

Figure21

HEATING/COOLING SYSTEM FOR INDWELLING HEAT EXCHANGE CATHETER

BACKGROUND OF THE INVENTION

[0001] 1. Related Applications

[0002] The present invention is a Continuation-in-Part of the U.S. patent application Ser. No. 09/965,560 filed on Sep. 25, 2001. This application claims priority from U.S. provisional patent application Ser. No. 60/492,818, filed Aug. 6, 2003.

[0003] 2. Field of the Invention

[0004] The present invention relates generally to methods and apparatus for exchanging heat with the body of a patient.

[0005] 3. Description of the Related Art

[0006] It has been discovered that the medical outcome for a patient suffering from severe brain trauma or from ischemia caused by stroke or heart attack is improved if the patient is cooled below normal body temperature (37° C.). Furthermore, it is also accepted that for such patients, it is important to prevent hyperthermia (fever) even if it is decided not to induce hypothermia. Moreover, in certain applications such as post-CABG surgery, it might be desirable to rewarm a hypothermic patient.

[0007] As recognized by the present invention, the above-mentioned advantages in regulating temperature can be realized by cooling or heating the patient's entire body. Moreover, the present invention understands that since many patients already are intubated with central venous catheters for other clinically approved purposes anyway such as drug delivery and blood monitoring, providing a central venous catheter that can also cool or heat the blood requires no additional surgical procedures for those patients. However, single purpose heat exchange catheters such as are made by Innercool Therapies of San Diego, Calif. and Radiant Medical of Portola Valley, Calif. can also be less optimally used.

[0008] Regardless of the particular catheter used, it is clear that heat must be removed from or added to the coolant that flows through the catheter. As recognized herein, it is desirable that a heat exchange system for a heat exchange catheter consume minimal energy and space. Small size is desired because space is often at a premium in critical care units. Moreover, as also recognized herein, for patient comfort it is desirable that such a heat exchange system generate a minimum amount of noise. As still further understood by the present invention, it is desirable that the heat exchange system be easy to use by health care personnel, and provide for monitoring systems and convenient temperature control. U.S. Pat. No. 6,146,411, incorporated herein by reference, discloses one such heat exchange system. It is the object of the present invention to still further address one or more of the above-noted considerations.

SUMMARY OF THE INVENTION

[0009] A heat exchange system for an indwelling heat exchange catheter includes a heat exchange bath that is configured to receive a conduit that carries working fluid to and from the catheter. A heating/coolant fluid is disposed within the bath to exchange heat with the working fluid. The heating/coolant fluid flows through a heat exchanger that includes a refrigerant and two or more compressors that are connected in parallel to each other. Moreover, a heating/

coolant fluid pump circulates the heating/coolant fluid between the heat exchanger and the heat exchange bath.

[0010] In a preferred embodiment, the compressors are variable speed direct current (DC) compressors. Also, a positive displacement gear pump preferably pumps the working fluid, e.g., saline, to and from the catheter. In a preferred embodiment, the pump is removably engaged with a motor.

[0011] In another aspect of the present invention, a heat exchange system for an indwelling heat exchange catheter includes a heat exchange bath that is configured to receive a conduit that carries working fluid to and from the catheter. A pump communicates with the conduit and pumps the working fluid to and from the catheter.

[0012] In yet another aspect of the present invention, a fluid pump assembly includes a pump support platform. A pump is removably engaged with the pump support platform. In this aspect, the pump pumps working fluid to and from an intravascular catheter.

[0013] In still another aspect of the present invention, a heat exchange system for an indwelling heat exchange catheter includes a heat exchange bath that is configured to receive a conduit that carries working fluid to and from the catheter. In this aspect of the present invention, a flow detector communicates with the conduit and detects when working fluid is flowing through the conduit.

[0014] In yet still another aspect of the present invention, a fluid flow detector includes

[0015] a clear housing and a paddle wheel that is rotatably disposed within the housing. The fluid flow detector further includes three infrared transmitter/receiver light emitting diode pairs. Each infrared transmitter/receiver light emitting diode pair establishes a signal path through the housing.

[0016] The details of the present invention, both as to its construction and operation, can best be understood in reference to the accompanying drawings, in which like numerals refer to like parts, and which:

BRIEF DESCRIPTION OF THE DRAWINGS

[0017] FIG. 1 is a schematic diagram of a heating/cooling system in accordance with the present invention;

[0018] FIG. 2 is a cross-sectional view of a heat exchange bath with the water glycol return line and level detector omitted for clarity;

[0019] FIG. 3 is a cross-sectional view of a fluid level detector;

[0020] FIG. 4 is a detailed cross-sectional view of a chiller/heater;

[0021] FIG. 5 is a flow chart of the overall operation logic of the present invention;

[0022] FIG. 6 is a flow chart of the linear mode operation logic of the present invention;

[0023] FIG. 7 is a flow chart of a first portion of the compressor control logic;

[0024] FIG. 8 is a flow chart of a second portion of the compressor control logic;

[0025] FIG. 9 is a flow chart of a third portion of the compressor control logic;

[0026] FIG. 10 is an exemplary graph of patient temperature and bath temperature versus time;

[0027] FIG. 11 is a schematic diagram of an alternative heating/cooling system;

[0028] FIG. 12 is a schematic diagram of an alternative refrigerating fluid circuit;

[0029] FIG. 13 is a side plan view of a saline pump assembly;

[0030] FIG. 14 is a top plan view of the saline pump assembly;

[0031] FIG. 15 is a top plan view of a pump support platform;

[0032] FIG. 16 is a bottom plan view of a pump;

[0033] FIG. 17 is a perspective view of an alternative saline pump assembly;

[0034] FIG. 18 is an exploded view of the alternative saline pump assembly;

[0035] FIG. 19 is, a side plan view of a preferred flow detector;

[0036] FIG. 20 is flow chart of the saline flow detection logic; and

[0037] FIG. 21 is flow chart of the glycol flow detection logic.

DETAILED DESCRIPTION OF THE PREFERRED EMBODIMENT

Description of the Heating/Cooling System

[0038] Referring initially to FIG. 1, a patient heating/cooling system is shown and generally designated 10. As shown, the system 10 includes three separate fluid circuits: a saline circuit (also referred to as the working fluid circuit), a water glycol circuit (also referred to as the heating/cooling fluid circuit), and a refrigerant circuit (also referred to as the refrigerating fluid circuit.)

[0039] Taking the saline circuit first, an indwelling heat exchange catheter 12 that can be inserted into a patient 13 during an operation is connected to a heat exchange bath 14 by a saline supply line 16. The supply line 16 is connected to a coiled or helical heat exchange tube 17 that is immersed in the bath 14 fluid to exchange heat therewith. In turn, the heat exchange tube 17 is connected to a peristaltic tubing saline pump 18 by fluid line 20. Preferably, the saline pump 18 draws saline from a saline reservoir 22 via fluid line 24. As shown, the saline reservoir 22 is disposed within a saline level detector 25 that, as described in detail below, helps control the saline pump 18 based on the level of saline in the level reservoir 22. It is to be understood that in a preferred embodiment, the saline pump 18 has four modes: a standby or off mode, two treatment modes (i.e., two treatment speeds), and an idle mode wherein the saline pump 18 operates very slowly, but does not stop. In the idle mode, the patient 13 is effectively thermally decoupled from the heating/cooling system 10.

[0040] As further shown in FIG. 1, a saline source 26 provides saline to the saline reservoir 22 via fluid line 28. In a preferred embodiment, the saline source 26 is an intravenous (IV) bag and a line clamp 27 is installed on fluid line 28 between the saline source 26 and the saline reservoir 22. It is to be understood that after the saline reservoir 22 is filled the line clamp 27 is clamped on fluid line 28 to isolate the saline source 26 from the saline reservoir 22. FIG. 1 shows a saline return line 29 communicates saline from the catheter 12 to the saline reservoir 22 to complete the saline circuit. It is to be appreciated that the tubes 16, 17, 20, 24, and 29 can be provided as a disposable IV tubing set.

[0041] FIG. 1 also shows a system controller 30 that is connected to the saline level detector 25 via electrical line 32 and electrical line 34, i.e., one for each infrared detector that is associated with the saline level detector 25 as described

below. Preferably, the system controller 30 is also connected to a safety switch 36 of the saline pump 18 via electrical line 38. As described in further detail below, the system controller 30 receives signals from the saline level detector 25 regarding the level of saline therein and uses this information to control the saline pump 18, including opening the safety switch 36 to de-energize the saline pump 18 under certain low saline level conditions.

[0042] It is to be understood that within the saline circuit, saline is circulated to and from the catheter 12 through the helical heat exchange tube 17 in the heat exchange bath 14. As described in detail below, the heat exchange bath 14 is filled with heating/cooling fluid, preferably water glycol. The water glycol can be heated or cooled in order to heat or cool the saline and thus, increase or decrease the temperature of the patient 13 into which the catheter 12 is inserted. Also, it is to be understood that the preferred working fluid is saline, but any similar fluid well known in the art can be used.

[0043] Now considering the water glycol circuit, the water glycol circuit communicates with a chiller/heater 40 via a water glycol supply line 42 and a water glycol return line 44. A water glycol pump 46 is installed in the water glycol return line 44 to circulate water glycol through the water glycol circuit. FIG. 1 shows that the heat exchange bath 14 is also in fluid communication with a water glycol reservoir 47 installed within a water glycol level detector 48 via fluid line 50. In accordance with principles described below, the water glycol level detector 48 is used to determine the level of water glycol within the heat exchange bath 14.

[0044] Further, the system controller 30 is connected to the chiller/heater 40 via electrical lines 52 and 54. Moreover, the system controller 30 is connected to a safety switch 55 at the water glycol pump 46 via electrical line 56 and to the coolant level detector 48 via electrical line 58 and electrical line 60. Thus, the system controller 30 can control the operation of the chiller/heater 40 based on signals from a temperature monitor, described below, and control the operation of the water glycol pump 46 based on level signals from infrared detectors, also described below, that are disposed within the water glycol level detector 48. As shown, the system controller 300 is also connected to a temperature sensor 57 placed at the outlet of the chiller/heater via electrical line 59. The controller 30 uses input from the temperature sensor 57 to control the chiller/heater 40 and other system 10 components.

[0045] It is to be understood that as the water glycol is pumped through the water/glycol circuit the chiller/heater 40 can heat or cool the water glycol. Within the heat exchange bath 14, the water glycol exchanges heat with the saline. Thus, the water glycol can be used to heat or cool saline and in turn, heat or cool the patient in which the catheter 12 is intubated. It is to be further understood that water glycol is the preferred heating/cooling fluid. However, any other fluid with similar properties can be used.

[0046] Now considering the third (refrigerant) circuit, a variable speed direct current (DC) compressor 62 is in fluid communication with the chiller/heater 40 via a refrigerant supply line 64 and a refrigerant return line 66. It is to be understood that the compressor 62 is filled with refrigerant, e.g., R134a. A compressor controller 68 is connected to the compressor 62 via an electrical line 70. In turn, the system controller 30 is connected to the compressor controller 68 via electrical line 72. The compressor controller 68 is also

connected to a heater, described below, within the chiller/heater 40 via electrical line 73.

[0047] It is to be understood that the system controller 30 receives temperature signals from the temperature monitor, described below, and uses these signals to control the operation of the compressor 62 and the heater. The compressor 62 is used to cool the water glycol that is pumped through the chiller/heater 40 by the water glycol pump 46.

[0048] Continuing to refer to FIG. 1, a DC power supply 74 is connected to the system controller 30 by an electrical line 76. In turn, the DC power supply 74 preferably is connected to an isolation transformer (XFMR) 78 by electrical line 80. The XFMR 78 can be connected to an alternating current (AC) input 82, e.g., a standard one hundred and twenty volt (120V) wall outlet, via a power cord 84. The system 10 can also be configured to work, accommodate one hundred to two hundred and forty volts AC (100-240 VAC).

[0049] As further shown in FIG. 1, a temperature monitor 86 is connected to the system controller 30 via an electrical line 88. A first patient temperature probe 90 and a second patient temperature probe 92 preferably are connected to the temperature monitor 86 via electrical lines 94 and 96, respectively. As intended herein, the temperature monitor 86 uses the temperature probes 90, 92 to monitor the temperature of the patient 13. Moreover, the temperature monitor 86 sends signals to the system controller 30 representing the temperature of the patient 13. These signals are used by the system controller 30 to control the operation of the chiller/heater 40, the saline pump 18, and the DC compressor 62.

[0050] FIG. 1 shows a display device 98 that is connected to the system controller 30 via electrical line 100 and electrical line 102. Preferably, the display device 98 provides a visual indication of the patient's temperature and the bath temperature. For example, the display device 98 can be used to output graphs of minute by minute patient temperature (for, e.g., twenty one days) and water glycol bath temperature. the display device 98 can also be used to provide information regarding the cooling power required by the patient, whether the system is heating or cooling the bath, and at which rate, e.g., low, medium, or maximum, the system is heating or cooling the bath. Further, the display device 98 can display the current patient temperature and the patient target temperature.

[0051] It is to be understood that a user can scroll the graphs left or right with respect to a stationary cursor within the center of the display. As the graphs are scrolled, information corresponding thereto can be displayed. As shown, the display device 98 also includes a control panel 104 to allow a user, i.e., a doctor or a nurse, to input data, such as a target patient temperature, to the system 10.

Description of the Heat Exchange Bath

[0052] Referring now to FIG. 2, details of one preferred, non-limiting heat exchange bath 14 are shown. FIG. 2 shows that the preferred heat exchange bath 14 includes a bottom 110 having a generally cylindrical continuous sidewall 112 extending therefrom. As shown, the bottom 110 of the bath 14 is formed with a hole 114 and the water glycol supply line 42 is connected thereto. A preferably vertical standpipe 116 extends from the end of the water glycol supply line 42 into the interior of the bath 14. In a preferred embodiment, the standpipe 116 is perforated along its length with a series of four hole rings 118 out of which water glycol flows into the

bath 14. These four hole rings 118 ensure radial movement of the water glycol through the heat exchange tubing 17, i.e., between and across the turns of the coil. It can be appreciated that in lieu of the standpipe 116, a small impeller (not shown) can be mounted on the bottom 110 of the bath 14 to circulate the water glycol therein.

[0053] As shown in FIG. 2, the generally spiral-shaped heat exchange tubing 17 is disposed within the bath 14 such that when the bath 14 is filled with water glycol the heat exchange tubing 17 is fully immersed in the water glycol. FIG. 2 shows that the saline supply line 16 is connected to one end of the heat exchange tubing 17. Conversely, the fluid line 20 from the saline pump 18 is connected to the other end of the heat exchange tubing 17. As shown, to center and support the spiral-shaped tubing set 120 around the standpipe 116, four vertical stanchions 122 (only two shown in FIG. 2) extend up from the bottom 110 of the bath 14 and touch the outer surface of the tubing set 120. In the alternative, the heat exchange tubing 17 can rest against the sidewall 112 of the bath 14.

[0054] FIG. 2 further shows that the bath 14 is covered by a lid 124. Preferably, the bottom of the lid 124 is spaced above the top of the water glycol within the bath 14 in order to establish a dead air space 126 between the lid 124 and the water glycol. This dead air space 126 acts as an insulator to minimize parasitic heat loads, control the evaporation of the water glycol, and prevent progressive overfilling of the bath 14 by condensation from the ambient air. Also, the lid 124 can be sealed against the wall 112 by a resilient, preferably silicone, gasket 128.

Description of the Level Detector

[0055] Referring now to FIG. 3, details of the preferred embodiment of the saline level detector 25 are shown. It is to be understood that the water glycol level detector 48 operates using the same principles as the saline level detector 25. As shown in FIG. 3, the saline level detector 25 includes a housing 130 that is preferably made from acetal, e.g., Dekin® manufactured by E.I. DuPont De Nemours & Co. of Delaware. The housing 130 is formed with a preferably "U" shaped central bore 132 in which the preferably clear saline reservoir 22 is disposed. FIG. 3 shows that the housing is formed with a first transverse bore 134, a second transverse bore 136, and a third transverse bore 138 leading to the central bore 132.

[0056] As shown, the saline level detector 25 includes a light emitter, e.g., an infrared light emitting diode (IR LED) 140, that is mounted in the first bore 134 on one side of the level detector 22. On the other hand, preferably two light detectors, such as a first IR detector 142 and a second IR detector 144, are placed on the opposite side of the saline level detector 25 from the LED 140 within the second and third transverse bores 136, 138. Preferably, the detectors 142, 144 are photodiodes or phototransistors.

[0057] In the presently preferred embodiment, IR LED 140 and the IR detectors 142, 144 are coplanar. Preferably, the IR LED 140 emits an IR light beam that can be detected by the first IR detector 142 if the saline level is below a predetermined level, e.g., the level of the IR LED 140 and the IR detectors 142, 144. In other words, if the saline is low, the IR light beam takes the path toward the first IR detector 142 as indicated by the dashed line 146. Conversely, if the saline is at the proper level within the saline level detector 25, the IR light beam is refracted so that it is detected by the

second IR detector **144**. In this case, the IR light beam takes the path indicated by line **148**.

[0058] It is to be understood that the IR light beam can be modulated, i.e. pulsed, e.g., at nine and a half kiloHertz (9.5 kHz), to avoid false detections caused, e.g., by other light sources placed in the same room as the level detector **25** and/or bubbles in the saline reservoir **22**. For this purpose, the first IR detector **142** and second IR detector **144** can be connected to upper and lower tone detectors **150**, **152**, respectively, which output signals only when they receive an input of; e.g., 9.5 kHz. It can be appreciated that when the saline level within the level detector falls below a predetermined level, the controller **30** can activate an alarm at the display device **98**. The alarm can include a visible alarm, e.g., a light, or an audible alarm, e.g., a buzzer. Moreover, when the saline level drops below the predetermined level the controller **30** can de-energize the saline pump **18** by opening the safety switch **36**.

Description of the Chiller/Heater

[0059] FIG. 4 shows the details regarding one preferred, non-limiting implementation of the chiller/heater **40**. As shown in FIG. 4, the chiller/heater **40** is a shell-and-tube heat exchanger having a lower chamber **160**, an upper chamber **162**, and plural tubes **164** communicating water glycol therebetween. It is to be understood that water glycol flows into the lower chamber **160**, up the tubes **164**, into the upper chamber **162**, and out of the upper chamber **162** to the heat exchange bath **14**. Refrigerant, e.g., R134a, flows around the tubes **164** to cool the water glycol therein. A resistive heater element **166** is disposed in the lower chamber **160** and extends partially up an enlarged center tube **168** for heating the water glycol in the chiller/heater **60**. As shown, the heater element **166** can include a built-in thermocouple temperature sensor **170** that can be used as described in detail below to determine if glycol is flowing through the chiller/heater **60**. It is to be appreciated that in a less preferred embodiment the chiller/heater **40** and the heat exchange bath **14** can be combined into a single unit. Moreover, it is to be appreciated that the temperature sensor **170** can be connected to the system controller.

Description of the Overall Operation Logic of the Present Invention

[0060] Referring now to FIG. 5, the overall operation logic of the present invention is shown and commences at block **200** wherein the controller **30** is initialized and the patient temperature (T_{pt}), the patient target temperature (T_{target}), and the bath temperature (T_{bath}) are received. Preferably, T_{pt} is received from the temperature monitor **86**, specifically from the second temperature probe **92**. Moving to block **202**, a temperature differential, ΔT , is determined by subtracting T_{pt} from T_{target} . Next, at decision diamond **204** it is determined whether the absolute value of ΔT is less than a predetermined amount, e.g., one tenth of a degree Celsius (0.1°C).

[0061] If the absolute value of ΔT is greater than 0.1°C ., the logic moves to block **206** where the system **10** enters maximum cooling mode or maximum warming mode. It is to be understood that if ΔT is negative the saline pump **18** is brought to full speed, the compressor **62** is turned on at high speed, and the heater **166** is turned off to cool the patient. Conversely, if ΔT is positive, the saline pump **18** is

brought to full speed, the compressor **62** is turned off, and the heater **166** is turned on to warm the patient.

[0062] Returning to decision diamond **204**, if the absolute value of ΔT is less than 0.1°C ., the logic moves to block **208** where the rate of change of T_{pt} with respect to time, dT_{pt}/dt , is determined using the following equation:

$$\left[\sum_{i=1}^n \left(\frac{n+1}{2} \right) - i * T_{pt}(i) \right] / \left[n * \left(\frac{1-n^2}{12} \right) \right]$$

[0063] where,

[0064] $n=10$ unless there has not yet been 10 minutes worth of patient temperature data

[0065] T_{pt} =Patient temperature

[0066] From block **208**, the logic moves to decision diamond **210** where it is determined whether the absolute value of dT_{pt}/dt is greater than thirty six hundredths of a degree Celsius per hour ($0.36^\circ \text{C}/\text{hr}$). If not, the logic continues to block **212** and a new T_{bath} is determined. The new T_{bath} is determined based on the rate of change of patient temperature. A higher rate of change results in a new T_{bath} that is further away from the current T_{bath} and a lower rate of change results in a new T_{bath} that is closer to the current T_{bath} . If dT_{pt}/dt is indeed greater than $0.36^\circ \text{C}/\text{hr}$ and negative, meaning that the patient **13** is being rapidly cooled and does not require saline circulation through the catheter, the logic moves to block **214** where the saline pump **18** is idled. Thereafter, the logic moves to **212** and a new T_{bath} is determined.

[0067] After block **212**, the logic proceeds to block **216**, wherein the compressor **62** and chiller/heater **40** are operated in accordance with the rules set forth below to achieve the new T_{bath} . Continuing to block **218**, in a preferred embodiment, the saline pump **18** is selectively idled per the following rules:

[0068] 1. Condition: A warming treatment has just started and the water glycol temperature is lower than T_{pt} . Rule: The saline pump **18** idled until the water glycol temperature is at least as warm as T_{pt} .

[0069] 2. Condition: A controlled heating/cooling rate treatment has just started and the water glycol temperature is not within one degree Celsius (1°C) of the water glycol reference temperature, T_{ref} ($T_{pt}-6^\circ \text{C}$. when cooling, $T_{pt}+1^\circ \text{C}$. when heating). Rule: The saline pump **18** is idled until the water glycol temperature is within 1°C . of T_{ref} .

[0070] 3. Condition: T_{pt} is within 0.1°C . of T_{target} and $dT_{pt}/dt < 0.36^\circ \text{C}/\text{hr}$. Rule: The saline pump **18** is idled at a very low rate until the water glycol temperature reaches T_{ref} .

[0071] 4. Condition: PID has been controlling the system, the error exceeds the overshoot threshold, and the water glycol temperature is warmer than T_{pt} . Rule: The saline pump **18** is idled until the water glycol temperature is lower than T_{pt} .

[0072] 5. Condition: PID has been controlling the system, the error exceeds the undershoot threshold, and the water glycol temperature is cooler than T_{pt} . Rule: The saline pump **18** is idled until the water glycol temperature is higher than T_{pt} .

[0073] After the saline pump 18 is selectively idled as described above, the logic proceeds to block 220 where the system enters the linear cooling mode, described below.

Description of the Linear Mode Operation Logic of the Present Invention

[0074] FIG. 6 shows the linear mode operation logic of the present invention. Commencing at block 230 a do loop is entered wherein while in the linear mode, the succeeding steps are performed. In the linear mode, several “fail safe” tests are monitored for to revert to maximum cooling or heating in the event that a rapid patient temperature change occurs. For instance, at decision diamond 232, if it is determined that ΔT is greater than one half a degree Celsius (0.5° C.) and has a negative sign, the system exits linear mode and enters maximum cooling mode at block 234. Also, if at decision diamond 236 it is determined that ΔT is positive and greater than three tenths of a degree Celsius (0.3° C.), the logic moves to block 238 where the linear mode is exited and the maximum warming mode is entered. Moreover, at block 240, dT_{pf}/dt is determined using the equation described above.

[0075] Proceeding to decision diamond 242, it is determined whether dT_{pf}/dt is greater than seven tenths of a degree Celsius per hour (0.7° C./hr) for the last ten (10) minutes. If so, the logic moves to block 234 where the linear mode is exited and the maximum cooling mode is entered. If dT_{pf}/dt is less than 0.7° C./hr for the last 10 minutes, the logic returns to decision diamond 232 and continues as described above.

Description of the Compressor Control Logic of the Present Invention

[0076] Referring now to FIG. 7, the control logic of the compressor is shown and commences at block 250 with a do loop, wherein after a new T_{bath} is determined, the following steps are performed. At decision diamond 252, it is determined whether the new T_{bath} is greater than the current T_{bath} . If the new T_{bath} is lower than the current T_{bath} , the logic moves to block 254 and the heater 166 is deactivated while the compressor 62 is activated at maximum speed to cool the water glycol.

[0077] Continuing to decision diamond 256, it is determined whether the current bath temperature is within a predetermined range, e.g., two-tenths degrees Celsius (0.2° C.) of the new T_{bath} . If not, the logic moves to block 258 where the cooling of the water glycol is continued. The logic then returns to decision diamond 256. If the current bath temperature is within the predetermined range of the new T_{bath} , the logic moves to block 260 wherein the compressor speed is progressively reduced.

[0078] From block 260, the logic moves to decision diamond 262 where it is determined whether the current temperature is stable at the new T_{bath} . If so, the logic moves to block 264 and the compressor 62 is held at the current speed to maintain the temperature at the new T_{bath} . If, at decision diamond 262, the temperature has not stabilized at the new T_{bath} , the logic moves to decision diamond 266 where it is determined whether the minimum compressor speed has been reached. If the minimum compressor speed has not been reached, the logic returns to block 260 and continues as described above. Conversely, if the minimum

compressor speed has been reached, the logic moves to block 268 where the heater power is progressively increased.

[0079] Next, the logic continues to decision diamond 270 where it is determined if the current temperature has stabilized at the new T_{bath} . If not, the logic returns to block 268 where the heater power continues to be progressively increased. If, on the other hand, the current temperature has stabilized at T_{bath} the logic moves to block 272 where the current power is maintained. Thereafter, the logic moves to block 264 where the compressor is idled at the current speed, in this case the lowest speed, in order to maintain the temperature at T_{bath} . In a preferred, non-limiting embodiment, the lowest temperature to which the bath can be commanded is one-half degree Celsius (0.5° C.).

[0080] Returning to decision diamond 252, if the new T_{bath} is greater than the current temperature, the logic proceeds to decision diamond 274 where it is determined whether the new T_{bath} is less than or equal to a predetermined upper bath limit, e.g., forty two degrees Celsius (42° C.). If the new T_{bath} is less than the upper bath limit, the logic moves to FIG. 8. However, if the new T_{bath} is equal to the upper bath limit, the logic moves to FIG. 9.

[0081] Proceeding to FIG. 8, if the new T_{bath} is less than the upper bath limit, the logic proceeds to block 276 where the compressor 62 is activated at minimum speed and the heater 166 is activated at maximum power. From block 276, the logic moves to decision diamond 278 where it is determined if the current temperature is within a predetermined range, e.g., two-tenths degrees Celsius (0.2° C.) of the new T_{bath} . If not, the logic proceeds to block 280 and the heating of the water glycol is continued. If the temperature is within the predetermined range, the logic continues to block 282 where the heater power is progressively reduced.

[0082] Next, at decision diamond 284, it is determined whether the current temperature has stabilized at the new T_{bath} . If the current temperature has stabilized at the new T_{bath} , the current heater power is maintained to maintain the temperature at the new T_{bath} . On the other hand, if the current temperature has not stabilized, the logic proceeds to decision diamond 288 where it is determined if the heater duty cycle is equal to zero (0). If not, the logic returns to block 282 where the progressive reduction of the heater power is continued.

[0083] If, at decision diamond 288, the heater duty cycle is equal to zero, indicating that the lowest heating power has been reached, logic continues to block 290 where the speed of the compressor 62 is progressively increased. Thereafter, at decision diamond 292, it is determined whether the current temperature has stabilized at the new T_{bath} . If the temperature has not stabilized, the logic moves to block 290 where the reduction of the compressor speed is continued. On the other hand, if the temperature of the compressor speed has stabilized at T_{bath} , the logic continues to block 294 where the current compressor speed is maintained. The logic then moves to block 286 and ends.

[0084] Returning to decision diamond 274 (FIG. 7), if the new T_{bath} is equal to the upper bath limit, the logic moves to FIG. 9. At block 296, the compressor is deactivated and the heater is activated at maximum power. From block 296, the logic moves to decision diamond 298 where it is determined whether the temperature is within a predetermined range, e.g., two-tenths degrees Celsius (0.2° C.), of the new T_{bath} . If not, the heating of the water glycol is continued at block 300. If the current temperature is within 3° C. of the

new T_{bath} , the logic proceeds to block **302** where the power of the heater **166** is progressively reduced. Then, at decision diamond **304**, it is determined whether the temperature has stabilized at the new T_{bath} . If so, the current heater power is maintained to maintain the temperature at the new T_{bath} . Conversely, if the temperature has not stabilized at the new T_{bath} , the logic continues to decision diamond **308** where it is determined whether the heater duty cycle has reached zero (0). If the heater duty cycle has not reached zero, the logic returns to block **302** where the progressive reduction of the heater power is continued. On the other hand, if the heater duty cycle has reached zero, the compressor **62** is briefly cycled in order to cool the water glycol. Next, at decision diamond **312**, it is again determined whether the temperature has stabilized at the new T_{bath} . If not, the logic returns to block **310** and the compressor is again briefly cycled to cool the water glycol. If, at decision diamond **312**, the temperature has stabilized at the new T_{bath} , the logic moves to block **306** and ends.

[0085] It is to be understood that the system described above has two nested closed-loop controllers: an outer loop and an inner loop. The outer loop is directly responsible for controlling the patient temperature and is driven by the temperature difference between T_{target} and T_{pt} . On the other hand, the inner loop is directly responsible for the coolant temperature, i.e., T_{bath} , that is established by the system controller **30**. It is further to be understood that the outer loop logic, i.e., the overall operation logic and linear mode operation logic describe above, resides in the system controller **30**. The inner loop control logic, i.e., the compressor control logic described above, resides in the compressor controller **68**. As intended by the present invention, when the compressor controller **68** receives a command to establish a new T_{bath} , the compressor controller **68** controls the compressor **62** and the heater **166**, as described above, in order to achieve the new T_{bath} .

[0086] In a preferred, non-limiting embodiment, the compressor controller **68** has two means of control over the compressor **62**. First, it can turn the power to compressor **62** on and off via a solid-state DC relay. Second, it can modulate the compressor speed between a maximum value, e.g., thirty five hundred revolutions per minute (3,500 RPM), and a minimum value, e.g., two thousand revolutions per minute (2,000 RPM).

[0087] Also, in a non-limiting embodiment, the compressor controller **68** has only duty-cycle control over the heater **166**. The compressor controller **68** can modulate the heater power anywhere between zero percent (0%), i.e., off, and one hundred percent (100%), i.e., on. Preferably, the heater **166** has a fixed one second (1 s) pulse period. Also, in a preferred embodiment the heater **166** has a maximum power of two hundred and forty watts (240 w). Thus, a fifty percent (50%) duty cycle corresponds to one hundred and twenty watts (120 w) of time-averaged input power to the water glycol and a twenty five percent (25%) duty cycle would correspond to sixty watts (60 w) of time-averaged input power.

Description of an Exemplary Graph of Patient Temperature and Bath Temperature versus Time

[0088] FIG. **10** shows one exemplary, non-limiting graph of T_{pt} , represented by line **320**, and T_{bath} , represented by line **322**, plotted versus time. As shown, the patient is initially in a hyperthermic state, i.e., the patient has a fever of thirty-nine degrees Celsius (39° C.). The patient is cooled from 39°

C. toward a T_{target} equal to thirty-six and one-half degrees Celsius (36.5° C.) preferably over a three hour period at a rate of eight tenths of a degree Celsius per hour (0.80° C/hr). This can be achieved by entering a maximum cooling mode where the T_{bath} is one-half a degree Celsius (0.5° C.).

[0089] Once T_{pt} reaches thirty six and six tenth degrees (36.6° C.), the saline pump **18** preferably is idled to thermally de-couple the patient **13** from the cooling system **10** and the T_{bath} is increased, e.g., by energizing the heater **166**, to approximately twenty-five degrees Celsius (25° C.). By thermally de-coupling the patient **13** from the cooling system **10**, T_{pt} will discontinue the rapid decrease described above while T_{bath} is increased.

[0090] After T_{bath} reaches 25° C., the saline pump **18** is returned to full speed to thermally couple the patient **13** to the cooling system **20**. As intended by the present invention, the higher T_{bath} slows the rate at which the patient **13** is cooled and helps to maintain T_{pt} in a state of equilibrium near T_{target} , e.g., within one-tenth of a degree Celsius (0.1° C.) of T_{target} . If necessary, T_{bath} can be slightly increased or decreased, e.g., less than five degrees Celsius (5° C.), as shown in order to maintain T_{pt} in the state of equilibrium described above.

Description of an Alternative Heating/Cooling System

[0091] Referring now to FIG. **11**, an alternative patient heating/cooling system is shown and generally designated **410**. Similar to the above-described system **10**, the system **410** shown in FIG. **11** includes three separate fluid circuits: a saline circuit (also referred to as the working fluid circuit), a water glycol circuit (also referred to as the heating/cooling fluid circuit), and a refrigerant circuit (also referred to as the refrigerating fluid circuit.)

[0092] Taking the saline circuit first, an indwelling heat exchange catheter **412** that can be inserted into a patient **413** during an operation is connected to a heat exchange bath **414** by a saline supply line **416**. The supply line **416** is connected to a coiled or helical heat exchange tube **417** that is immersed in the bath fluid to exchange heat therewith. In turn, the heat exchange tube **417** is connected an air trap vessel **418** by fluid line **420**. The air trap vessel **418** is surrounded by an air trap detector **419**. As shown, the air trap vessel **418** is connected to a saline pump **422** by fluid line **424**.

[0093] It is to be understood that the air trap detector **419** is identical in construction to the saline level detector **25** described above and shown in FIG. **3** and can be used to detect when air is introduced into the working fluid circuit downstream from the pump **422**, e.g., by the pump **422** itself. Accordingly, if air is detected in the air trap vessel **418**, the pump **422** is immediately shut down by a controller in accordance with the principles discussed earlier.

[0094] As further shown in FIG. **11**, a saline source **426** provides saline to the pump **422** via fluid line **427**. FIG. **11** shows a saline return line **428** that communicates saline from the catheter **412** to the saline reservoir **426** to complete the saline circuit. A saline flow detector **429**, described in detail below, is installed along the saline return line **428** between the catheter **412** and the saline reservoir **426**. FIG. **11**, shows that the saline flow detector **429** provides feedback to the system controller, described below, via electrical line **425**.

[0095] FIG. **11** also shows a system controller **430** that is connected to the air trap detector **419** via electrical line **432**

and electrical line 434, i.e., one for each infrared detector that is associated with the air trap detector 419. Preferably, the system controller 430 is also connected to a safety switch 436 of the saline pump 422 via electrical line 438. As described in further detail below, the system controller 430 receives signals from the air trap detector 419 regarding the level of saline therein and uses this information to control the saline pump 422, including opening the safety switch 436 to de-energize the saline pump 422 under certain low saline level conditions. It is to be understood that within the saline circuit, saline is circulated to and from the catheter 412 through the helical heat exchange tube 417 in the heat exchange bath 414.

[0096] Now considering the water glycol circuit, the water glycol circuit communicates with a chiller/heater 440 via a water glycol supply line 442 and a water glycol return line 444. A water glycol pump 446 is installed in the water glycol supply line 442 to circulate water glycol through the water glycol circuit. FIG. 11 shows that the heat exchange bath 414 is also in fluid communication with a water glycol reservoir 447 via fluid line 450. As shown, the water glycol reservoir is installed within a water glycol level detector 448. In accordance with the principles described above, the water glycol level detector 448 can be used to determine the level of water glycol within the heat exchange bath 414.

[0097] Further, the system controller 430 is connected to the chiller/heater 440 via electrical lines 452 and 454. Moreover, the system controller 430 is connected to the coolant level detector 448 via electrical line 458 and electrical line 460. Thus, the system controller 430 can control the operation of the chiller/heater 440 based on signals from a temperature monitor, described below, and control the operation of the water glycol pump 446 based on level signals from the infrared detectors that are disposed within the water glycol level detector 448. As shown, the system controller 430 is also connected to a temperature sensor 457 placed at the outlet of the chiller/heater via electrical line 459. The controller 430 uses input from the temperature sensor 457 to control the chiller/heater 440 and other system 410 components.

[0098] It is to be understood that as the water glycol is pumped through the water/glycol circuit the chiller/heater 440 can heat or cool the water glycol. Within the heat exchange bath 414, the water glycol exchanges heat with the saline. Thus, the water glycol can be used to heat or cool saline and in turn, heat or cool the patient in which the catheter 412 is installed. It is to be further understood that water glycol is the preferred heating/cooling fluid. However, any other fluid with similar properties can be used.

[0099] Now considering the third (refrigerant) circuit, a variable speed direct current (DC) compressor 462 is in fluid communication with the chiller/heater 440 via a refrigerant supply line 464 and a refrigerant return line 466. It is to be understood that the compressor 462 is filled with refrigerant, e.g., R134a. A compressor controller 468 is connected to the compressor 462 via an electrical line 470. In turn, the system controller 430 is connected to the compressor controller 468 via electrical line 472. The compressor controller 468 is also connected to a heater (FIG. 4) within the chiller/heater 440 via electrical line 473.

[0100] It is to be understood that the system controller 430 receives temperature signals from the temperature monitor, described below, and uses these signals to control the operation of the compressor 462 and the heater. The com-

pressor 462 is used to cool the water glycol that is pumped through the chiller/heater 440 by the water glycol pump 446. [0101] Continuing to refer to FIG. 11, a DC power supply 474 is connected to the system controller 430 by an electrical line 476. In turn, the DC power supply 474 preferably is connected to an isolation transformer (XFMR) 478 by electrical line 480. The XFMR 478 can be connected to an alternating current (AC) input 482, e.g., a standard one hundred and twenty volt (120V) wall outlet, via a power cord 484. It can be appreciated that a power supply having a low current leakage can be used and if it is indeed used, the XFMR 478 can be eliminated.

[0102] As further shown in FIG. 11, a temperature monitor 486 is connected to the system controller 430 via an electrical line 488. A first patient temperature probe 490 and a second patient temperature probe 492 preferably are connected to the temperature monitor 486 via electrical lines 494 and 496, respectively. As intended herein, the temperature monitor 486 uses the temperature probes 490, 492 to monitor the temperature of the patient 413. Moreover, the temperature monitor 486 sends signals to the system controller 430 representing the temperature of the patient 413. These signals are used by the system controller 430 to control the operation of the chiller/heater 440, the saline pump 418, and the DC compressor 462.

[0103] FIG. 11 shows a display device 498 that is connected to the system controller 430 via electrical line 500 and electrical line 502. Preferably, the display device 498 can provide a visual indication of the patient's temperature and the bath temperature. For example, the display device 498 can be used to output graphs of minute by minute patient temperature (for, e.g., twenty one days) and water glycol bath temperature. The display device 498 can also be used to provide information regarding the cooling power required by the patient, whether the system is heating or cooling the bath, and at which rate, e.g., low, medium, or maximum, the system is heating or cooling the bath. Further, the display device 498 can display the current patient temperature and the patient target temperature.

[0104] It is to be understood that a user can scroll the graphs left or right with respect to a stationary cursor within the center of the display. As the graphs are scrolled, information corresponding thereto can be displayed. As shown, the display device 498 also includes a control panel 504 to allow a user, i.e., a doctor or a nurse, to input data, such as a target patient temperature, to the system 410.

Description of an Alternative Refrigerating Fluid Circuit

[0105] Referring to FIG. 12 an alternative refrigerating fluid circuit is shown and is generally designated 600. FIG. 12 shows that the refrigerating fluid circuit 600 includes a first compressor 602 and a second compressor 604 that are connected in parallel to each other and connected in series to a condenser 606 and an evaporator 608. An expansion valve 610 is also connected between the condenser 606 and the evaporator 608 to complete the fluid circuit. As shown in FIG. 12, glycol is pumped to and from the evaporator 608 from a glycol bath. In a preferred embodiment, the compressors 602, 604 are variable speed direct current (dc) compressors that can be controlled by a controller, e.g., a computer or any other microprocessor. In order to prevent one or both of the compressors 602, 604 from stalling during operation, the controller preferably includes an algorithm that can prevent either compressor from being energized

when the other compressor is fully loaded. It can be appreciated that the two compressors **602**, **604** working in parallel with each other increase the cooling power of the refrigerating fluid circuit **600**.

Description of a Saline Pump Assembly

[0106] FIGS. **13** and **14** show an exemplary, non-limiting saline pump assembly, generally designated **650**. As shown in FIGS. **13** and **14**, the pump assembly **650** includes a diaphragm pump **652** that is removably engaged with a pump support platform **654**. In one non-limiting embodiment, the pump **652** is similar to the high efficiency diaphragm pump disclosed in U.S. Pat. Nos. 5,791,882 and 5,800,136, incorporated herein by reference.

[0107] FIG. **13** shows that the pump support platform **654** includes an upper plate **656** and a lower plate **658** that, in a preferred embodiment, are attached to each other, e.g., by threaded fasteners. As shown in FIG. **13**, plural feet **660** extend from the lower plate **658** and provide stable support for the pump support platform **654**. FIG. **13** also shows that a pump drive assembly **662** is incorporated into the lower plate **658** of the pump support platform **654**. The pump drive assembly **662** includes a motor and a drive shaft, described below, that extends through the upper plate **656** of the pump support platform **654** and engages the pump **650**.

[0108] As shown in FIGS. **13** and **14**, the pump support platform **654** includes a quick-release locking arm **664** that prevents the pump **652** from being disengaged with the pump support platform **654**—unless the locking arm **664** is rotated to release the pump **652**. FIGS. **14** and **15** also show that the pump support platform **654** includes an overflow bore **665** through which any saline that may leak from the pump **652** can flow. FIG. **14** further shows that the pump **652** includes an inlet **666** and an outlet **668**. As discussed above, the pump **652**, i.e., the outlet **668** thereof, can be connected to the air trap vessel **418** (FIG. **11**) that is downstream from the pump **652**.

[0109] Referring now to FIG. **15**, further details concerning the pump support platform **654** are shown. FIG. **15** shows that the upper plate **656** of the pump support platform **654** is formed with a generally cylindrical pump locking bore **672**. The outer periphery of the pump locking bore **672** is radially formed with a first slot **674**, a second slot **676**, and a third slot **678**. As shown, each slot **674**, **676**, **678** is equally spaced around the outer periphery of the pump locking bore **672**. Also, each slot **674**, **676**, **678** is curved to match the radius of curvature of the pump locking bore **672** and each slot **674**, **676**, **678** terminates in a semi-cylindrical bay **680**, **682**, **684**. FIG. **15** also shows that a drive shaft **686** extends from the pump drive assembly **662** (FIG. **13**) through the upper plate **656**. It is to be understood that the pump drive assembly **662** includes a motor **687** for rotating the drive shaft **686**. The motor **687** can be directly connected to the drive shaft **686**, as shown, or it can be geared thereto.

[0110] FIG. **16** shows further details concerning the construction of the pump **652**. As shown, the pump **652** includes a generally cylindrical lower housing **688**. A first generally cylindrical leg **690**, a second generally cylindrical leg **692**, and a third generally cylindrical leg **694** are equally spaced around the periphery of the lower housing **688**. FIG. **16** shows that the pump **652** further includes a drive shaft receptacle **696** into which the drive shaft **686** (FIG. **15**) extends when the pump **652** is removably engaged with the

pump support platform **654**. It is to be understood that the drive shaft **686** is keyed to the drive shaft receptacle **696**.

[0111] It can be appreciated that the pump **652** can be engaged with the pump support platform **654** by aligning the cylindrical legs **690**, **692**, **694** with the semi-cylindrical bays **680**, **682**, **684** established by the pump locking bore **672**. The drive shaft **686** is also aligned with the drive shaft receptacle **696**. In this relationship, the pump **652** can be slid toward the pump support platform **654** until the lower housing **688** of the pump **652** contacts the upper plate **656** of the pump support platform **654**. The pump **652** is then rotated within the pump locking bore **672** until each leg **690**, **692**, **694** of the pump **652** reaches a respective end of each slot **674**, **676**, **678** formed by the pump locking bore **672**. It is to be understood that during installation of the pump **652** on the pump support platform **654**, one leg **690**, **692**, **694** of the pump **652** (any leg, thereof) rides against and then past the quick-release locking arm **664** until the quick-release locking arm **664** clears the leg **690**, **692**, **694** and snaps under spring bias to a position to prevent the pump **652** from being removed from the pump support platform **654**.

[0112] In accordance with the principles of the present invention, a pump **652** can be easily engaged and disengaged with the pump support platform **654** during use. Thus, a first sterilized pump can be used in conjunction with the treatment of a first patient. After treatment has concluded, the now-used pump can be removed and replaced with a second sterilized pump to be used in conjunction with the treatment of a second patient. The pump support platform **654** (and the motor therein) need not be replaced for each new pump and the costs of utilizing the heat/cooling system of the present invention are reduced.

Description of an Alternative Saline Pump Assembly

[0113] In an alternative embodiment, as shown in FIGS. **17** and **18**, a saline pump assembly **700** includes a pump support platform **702** and a positive displacement gear pump **704**. In non-limiting embodiments, the gear pump **704** can incorporate some or all of the features set forth in U.S. Pat. Nos. 6,270,324; 6,210,138; 6,158,994; 5,494,416; 5,219,274; 5,165,868; and 4,065,235, all of which are incorporated herein by reference. As shown in FIGS. **17** and **18**, the pump support platform **702** includes a pump drive motor **706** that is preferably a brushless, direct current motor.

[0114] FIGS. **17** and **18** show that the pump support platform **702** includes a first support collar **708** and a second support collar **710** that fit into a generally cylindrical pump locking bore **712** formed in the support platform **702**. Plural fasteners **714** can be used to affix the support collars **708**, **710** to the support platform **702**. It is to be understood that the gear pump **704** fits into the support collars after they are inserted in the bore **712**. As shown in FIG. **18**, a first spring loaded ball plunger **715** and a second spring loaded ball plunger **716** are provided and can be used to removably engage the gear pump **704** with the support platform **702**. One or more alignment pins **713** can be used to properly align the gear pump **704** when it is engaged with the support platform **702**. When the gear pump **704** is installed in the support platform **702**, the ball plungers **715**, **716** engage a metal flange **717** around the gear pump **704** and provide a downward force on the metal flange **717** in order to keep the gear pump **704** installed in the support platform **702**.

[0115] As shown in FIGS. **17** and **18**, a first optical sensor **718** and a second optical sensor **719** are installed on the

upper surface of the support platform **702** and can be used to detect the presence of the gear pump **704** on the support platform **702**. It is to be understood that each optical sensor **718**, **719** includes an emitter (not shown) and a detector (not shown) that are configured to transmit an optical signal toward the space in which the gear pump **704** occupies when it is properly installed and detect reflection from the gear pump **704** when it is, indeed, properly installed.

[0116] FIG. **18** further shows that the gear pump **704** includes a cylindrical magnet **720** that extends from the gear pump **704**. It is to be understood that the cylindrical magnet **720** is attached to a drive shaft (not shown) within the gear pump **704** and as the cylindrical magnet **720** rotates it rotates the drive shaft. Further, the motor **706** includes a cup-shaped magnet **722** that is sized and shaped to receive the cylindrical magnet **720** and magnetically engage the cylindrical magnet **720**. The cup-shaped magnet **722** is coupled to a drive shaft (not shown) within the motor **706** and the motor **706** can be energized to rotate the cup-shaped magnet **722**.

[0117] With this structure, the gear pump **704** can be removably engaged with the support platform **702**. When the gear pump **704** is engaged with the support platform **702**, the cylindrical magnet **720** is magnetically coupled to the cup-shaped magnet **722**. Accordingly, as the cup-shaped magnet **722** is rotated by the motor **706** it causes the cylindrical magnet **720** to rotate and which, in turn, causes the gear pump **704** to pump fluid therethrough.

[0118] It is to be understood that for overpressure protection, the gear pump **704** includes a bypass relief valve (not shown) that opens on high pressure. In lieu of a bypass relief valve, the magnets **720**, **722** can be magnetized such that the magnetic coupling established therebetween can be broken under conditions of overpressure. Moreover, the speed of the pump **704** can be established for the desired heat exchange rate.

Description of a Preferred Saline Flow Detector

[0119] Referring now to FIG. **19**, a preferred, non-limiting embodiment of a saline flow detector is shown and generally designated **800**. As shown in FIG. **19**, the flow detector **800** includes a preferably clear, plastic housing **802** having an inlet **804** and an outlet **806**. A lightweight, preferably plastic paddle wheel **808** is installed within the housing **802** on an axle **810**. FIG. **19** shows that the paddle wheel **808** includes a central hub **812** from which preferably three opaque, plastic paddles **814** extend radially (it is to be understood that each paddle **814** includes a pair of opposing paddle blades). As shown, the paddles **814** are positioned around the hub **812** approximately one-hundred and twenty degrees (120°) from each other. It can be appreciated that fluid flowing from the inlet **804** to the outlet **806** flows tangential to the paddle wheel **808** and causes it to spin. Moreover, three opaque walls **815** are formed around the paddle wheel **808** between alternating pairs of adjacent paddle blades.

[0120] As shown in FIG. **19**, preferably three infrared transmitter/receiver light emitting diode (IR T/R LED) pairs **816** can be placed such that the housing **802** is between each IR T/R LED pair **816** and each IR T/R LED pair **816** can send and receive a signal through the housing **802** across the paddle wheel **808** to detect rotation of the paddle wheel **808** when fluid flows through the housing **802**. In a preferred embodiment, the IR T/R LED pairs **816** are positioned on an imaginary circle concentric with the axle **810**. Moreover, the IR T/R LED pairs are arranged so that a center pair **816** is

aligned with the axle **810** and two side pairs **816** flank the center pair **816**. Each side pair is approximately plus-or-minus sixty-four degrees ($\pm 64^\circ$) from the center pair **816** on the imaginary circle. This arrangement insures that that regardless of the position of the pin wheel **808**, one of the three signal paths established by the IR T/R LED pairs **816** through the housing **802** is always unblocked by the paddle wheel **808**.

[0121] FIG. **19** further shows that each IR T/R LED pair **816** is connected to a processor **818** that, in turn, is connected to a system controller **820**. The processor **818** includes a program that, based on the signals received from the IR T/R LED pairs **816**, allows the processor **818** to determine if the paddle wheel **808** is rotating and fluid is flowing through the housing and accordingly, the working fluid circuit. If not, an alarm can be activated.

Description of the Saline Flow Detection Logic

[0122] FIG. **20** shows the saline flow detection logic that commences at block **850** wherein the flow detector **800** is energized, i.e., its power is turned on. Moving to decision diamond **852**, it is determined whether pulses are being received at the processor **818**. The pulses represent motion of the paddle wheel **808**, i.e., the motion of the paddles through the light beams established by the IR T/R LED pairs **816**. If there are indeed pulses, the logic moves to decision diamond **854** where it is determined whether a timer has expired. If the timer has not expired, the logic loops back to decision diamond **852** and continues as described above. If so, the logic moves to block **856** and an "optics error" message is presented to the user. The logic then ends at state **858**.

[0123] Returning to decision diamond **852**, if pulses are not present, the logic moves to decision diamond **860** where it is determined whether all three IR T/R LED pairs **816** are on. If so, the logic moves to decision diamond **862** where it is determined if all three IR T/R LED pairs **816** are operating properly. This can be determined, e.g., by sequentially toggling the IR T/R LED pairs **816** on and off. If it is determined that the IR T/R LED pairs **816** are not operating properly, the logic moves to block **856** where an "optics error" message is presented to the user. The logic then ends at state **858**. Otherwise, an "optics ok, no pinwheel" message is presented to the user. The logic then ends at state **858**.

[0124] At decision diamond **860**, if all three IR T/R LED pairs **816** are not on, the logic moves to decision diamond **866** where it is determined if two out of three of the IR T/R LED pairs **816** are on. If so, the logic moves to decision diamond **868** where it is determined whether the two IR T/R LED pairs **816** are operating properly, e.g., by toggling the two IR T/R LED pairs **816** on and off. If the two IR T/R LED pairs **816** are not operating properly, the logic moves to block **856** where an "optics error" message is presented to the user. The logic then ends at state **858**. Otherwise, if the two IR T/R LED pairs **816** are operating properly, the logic moves to decision diamond **870** where it is determined if signal pulses are present. If not, the logic moves to block **872** where a "no flow" message is presented to the user. The logic then loops back to decision diamond **870**.

[0125] At decision diamond **870**, if pulses are present, the logic moves to decision diamond **874** where it is determined if all three IR T/R LED pairs **816** are operating properly. If so, an "optics ok, flow" message is indicated to the user at block **876**. Otherwise, an "optics warning, flow" message is

indicated to the user at block **878**. From block **876** or block **878**, the logic moves to block **880** where it is determined if pulses are present. If pulses are indeed present, the logic returns to decision diamond **874** and continues as described above. Conversely, if pulses are not present, the logic proceeds to block **882** where a “no flow” message is presented to the user. The logic then ends at state **858**.

[0126] Returning to decision diamond **866**, if it is determined that two IR T/R LED pairs **816** are not on, the logic continues to decision diamond **884** where it is determined if one IR T/R LED pair **816** is on. If not, the logic proceeds to block **856** where an “optics error” is presented to the user. The logic then ends at state **858**. If the IR T/R LED pair **816** is on, the logic moves to decision diamond **886** where it is determined whether the IR T/R LED pair **816** is operational. If the IR T/R LED pair **816** is not operational, the logic continues to block **856** where an “optics error” is presented to the user. The logic then ends at state **858**. If the IR T/R LED pair **816** is operating properly, the logic moves to decision diamond **870** and continues as described above.

[0127] With the above logic, the flow detector **800** can indicate flow through the working fluid circuit only if signal pulses are output by the flow detector **800**. Moreover, while the paddle wheel **808** is rotating, the processor **818** is constantly testing each of the IR T/R LED pairs **816** by sequentially toggling each of the IR T/R LED pairs **816** on and off and reading the signals output thereby.

Description of the Glycol Flow Detection Logic

[0128] Referring now to FIG. 21, the glycol flow detection logic is shown and commences at block **900** with a do loop wherein periodically, the following steps are performed. At block **902**, the heater **166** (FIG. 4) is periodically pulsed. Moving to decision diamond **904**, it is determined if there is a sudden increase in temperature (e.g., above a predetermined quantity), as indicated by the thermocouple temperature sensor **170** (FIG. 4). If not, the logic ends at state **906**. Otherwise, the logic proceeds to block **908** where it is indicated to a controller that there is a problem with the glycol circulation. It can be appreciated that in response to the indication of a problem, the controller can shut off power to the heater at block **910**.

Relevant Equations

[0129] As described above, the power required to cool the patient can be viewed at the display device **98**. It is to be understood that the power equation described below is most accurate for a patient having a weight of approximately seventy-five kilograms (75 kg).

[0130] Accordingly, the power used to cool a patient can be determined using the following equation:

$$\left(\frac{dT_{pt}/dt \text{ } ^\circ\text{C./min} \times 60 \text{ min/hr}}{1.4 \text{ } ^\circ\text{C./hr}} \right) \times 100w \times (-1)$$

[0131] where:

[0132] dT_{pt}/dt is determined by the equation disclosed above.

[0133] While the particular HEATING/COOLING SYSTEM FOR INDWELLING HEAT EXCHANGE CATHETER as herein shown and described in detail is fully capable of attaining the above-described aspects of the

invention, it is to be understood that it is the presently preferred embodiment of the present invention and thus, is representative of the subject matter which is broadly contemplated by the present invention, that the scope of the present invention fully encompasses other embodiments which may become obvious to those skilled in the art, and that the scope of the present invention is accordingly to be limited by nothing other than the appended claims, in which reference to an element in the singular is not intended to mean “one and only one” unless explicitly so stated, but rather “one or more.” All structural and functional equivalents to the elements of the above-described preferred embodiment that are known or later come to be known to those of ordinary skill in the art are expressly incorporated herein by reference and are intended to be encompassed by the present claims. Moreover, it is not necessary for a device or method to address each and every problem sought to be solved by the present invention, for it is to be encompassed by the present claims. Furthermore, no element, component, or method step in the present disclosure is intended to be dedicated to the public regardless of whether the element, component, or method step is explicitly recited in the claims. No claim element herein is to be construed under the provisions of 35 U.S.C. section 112, sixth paragraph, unless the element is expressly recited using the phrase “means for.”

We claim:

1-22. (canceled)

23. An assembly, comprising:

a platform supporting a motor; and

a pump engaged with the platform for pumping working fluid to and from a cooling member for a patient, the motor being coupled to the pump to provide power to the pump when the pump is engaged with the platform; wherein the pump support platform includes a first arcuate support collar and a second arcuate support collar, the collars being received in a pump bore in the platform, the pump being received by the support collars in the pump bore.

24. The assembly of claim **23**, wherein the pump is removably coupled to the motor.

25. The assembly of claim **23**, comprising:

a magnet extending from the pump and coupled thereto; a cup-shaped member coupled to the motor to receive the magnet and magnetically engage the magnet such that as the cup-shaped member is rotated by the motor it causes the magnet to rotate which, in turn, causes the pump to pump fluid.

26. The assembly of claim **23**, wherein the platform comprises:

a pump locking bore, the pump removably engaging the pump locking bore.

27. The assembly of claim **23**, comprising:

at least one sensor for detecting the presence of the pump when it is engaged with the platform.

28. The assembly of claim **23**, wherein the pump is a diaphragm pump.

29. The assembly of claim **23**, wherein the platform includes an overflow bore through which any saline that may leak from the pump can flow.

30. The assembly of claim **23**, wherein the pump is a gear pump.

31. The assembly of claim **23**, wherein a magnetic coupling is established between the cup-shaped member and the magnet to be broken under a predetermined overpressure.

32. An assembly, comprising:

a support supporting a motor; and

a pump engaged with the support and configured for pumping working fluid to and from a heat exchange member, the motor being coupled to the pump to provide power to the pump;

the support including a first arcuate support collar and a second arcuate support collar, the collars being received in a pump bore in the support, the pump being received by the support collars in the pump bore.

33. The assembly of claim **32**, comprising:

at least one sensor for detecting the presence of the pump when it is engaged with the support.

34. The assembly of claim **32**, wherein the pump is a diaphragm pump.

35. The assembly of claim **32**, wherein the support includes an overflow bore through which any saline that may leak from the pump can flow.

36. The assembly of claim **32**, wherein the pump is a gear pump.

37. The assembly of claim **32**, comprising:

a magnet extending from the pump and coupled thereto; a cup-shaped member coupled to the motor to receive the magnet and magnetically engage the magnet such that as the cup-shaped member is rotated by the motor it causes the magnet to rotate which, in turn, causes the pump to pump fluid.

38. The assembly of claim **32**, comprising first and second magnetic elements respectively coupled to the pump and the

motor to couple the pump to the motor, a magnetic coupling being established by the magnetic elements to be broken under a predetermined overpressure.

39. An assembly, comprising:

a support configured for supporting a motor;

a pump engaged with the support and configured to pump working fluid to and from a heat exchange member to exchange heat with a patient, the motor being couplable to the pump to provide power to the pump;

at least a first arcuate support collar and a second arcuate support collar, the collars being received in a pump bore in the support, the pump being received by the support collars in the pump bore.

40. The assembly of claim **39**, comprising:

first and second magnetic elements respectively coupled to the pump and the motor to couple the pump to the motor, a magnetic coupling being established by the magnetic elements to be broken under a predetermined overpressure.

41. The assembly of claim **39**, wherein the pump is a gear pump.

42. The assembly of claim **39**, wherein the first magnetic element is established at least in part by a magnet extending from the pump and coupled thereto and the second magnetic element is established at least in part by a cup-shaped member coupled to the motor to receive the magnet and magnetically engage the magnet such that as the cup-shaped member is rotated by the motor it causes the magnet to rotate which, in turn, causes the pump to pump fluid.

* * * * *