

(19)
(12)

(KR)
(Y1)

(51) 。 Int. Cl. 7
A44C 17/00

(45)
(11)
(24)

2003 05 22
20-0314133
2003 05 10

(21) 20-2003-0005628 ()
(22) 2003 02 26
(62) 2003-0011860
: 2003 02 26

2003 02 26

(73) 1 606-10

(72) 1 606-10

(74)

:

가 :

(54)

, ()
0.001~0.025mm 가 () ,
;
;
() 가 가 ; ,
가 가 .

1
2
3
4
5
6

* *

1 : 10 :
10' : 20 :
30 : M :
G : P :
S1 : S2 :
S3 : S4 :
S5 : 가 T :

, 6 (1) (10') 가 (M)
가 (M) (1) (10') (M) 가 (1) (M)
, (1) 가 (M) 가 0.3~0.5mm 가 , 가
(M) 가 (M) 가 , 가

1

(10) (20) (30) (30)

(1) (10) (10) (1) (20) (20) (1)

(30) 0.001~0.025mm (10) (20) 가 (30)

2

1 가 (10) (20)

(30) (1)

3

(30) (10) (20) (10) (20)

4

(30) (1) (S3) 2가

(S3) 4

4

(20) (30) (30) (20) (S2) (S1)

(S2) (30) (20) () ()

30) (S3) 0.02~0.025mm

(S3) (20) (30) (10)

(S4)

(S2) (S4) 가

(S4) (1) 가 가 (S5)

() (20) (S3) (30)

(30) 0.001~0.002mm 가 , (30) 가 .

가 (1) (30) (T) (P) (G) ,

(1) 5 가 .

가 .

가 , 가

가 가 0.3~0.5mm 가 , 가 .

가 가 .

가 , 가

(57)

1.
 (10) (20) 0.001~0.025mm 가 (30)

1

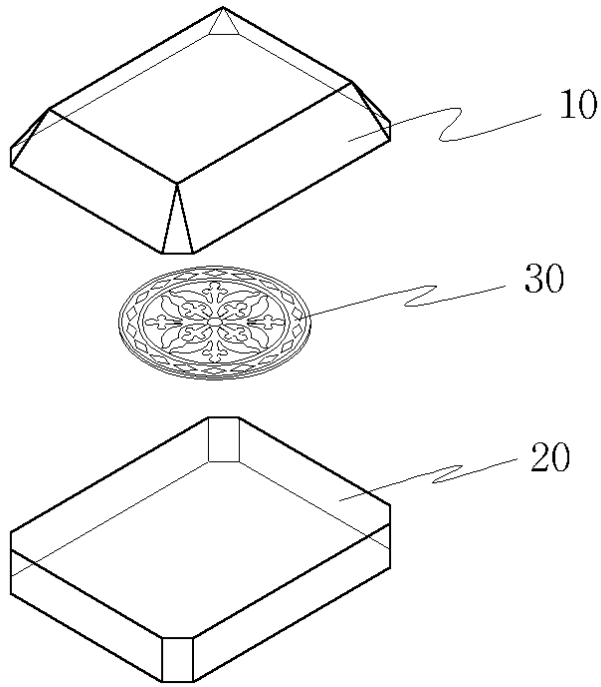

2

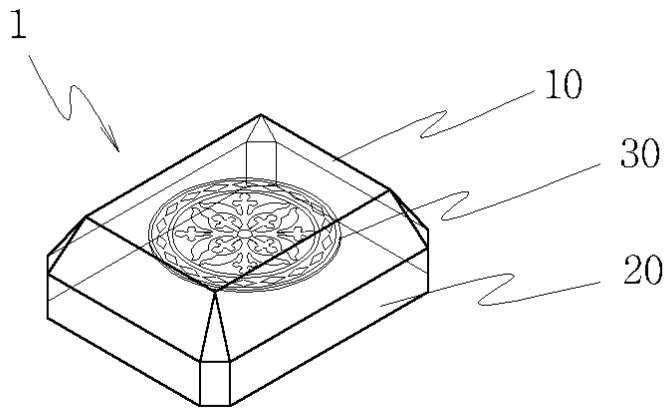

3

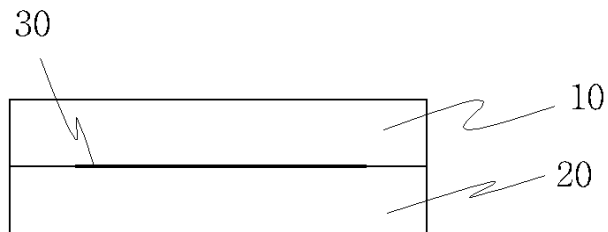

4

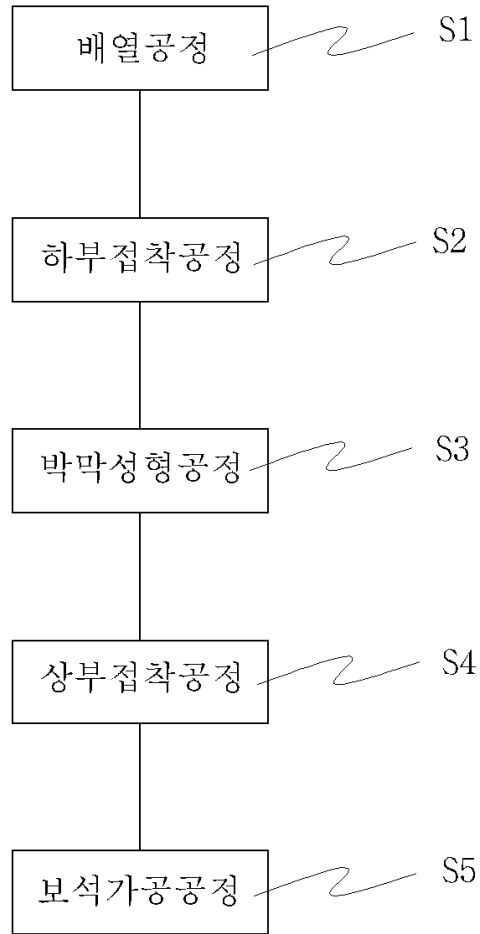

5

