

(12) UK Patent Application (19) GB (11) 2 365 714 (13) A

(43) Date of A Publication 20.02.2002

(21) Application No 0006217.4

(22) Date of Filing 15.03.2000

(71) Applicant(s)
**Conexant Digital Infotainment Limited
(Incorporated in the United Kingdom)
Castlegate, Tower Hill, BRISTOL, BS2 0JA,
United Kingdom**

(72) Inventor(s)
Thomas Foxcroft

(74) Agent and/or Address for Service
**Haseltine Lake & Co
Imperial House, 15-19 Kingsway, LONDON,
WC2B 6UD, United Kingdom**

(51) INT CL⁷
H04L 27/26

(52) UK CL (Edition T)
H4P PAX

(56) Documents Cited
**GB 2346052 A EP 1063824 A2
EP 0853410 A2 WO 99/12305 A1
US 5848107 A**

(58) Field of Search
**UK CL (Edition S) H4P PAN PAX
INT CL⁷ H04L 27/26
ONLINE: EPODOC, JAPIO, WPI**

(54) Abstract Title
Minimising effects of inter-symbol interference in receiver

(57) A television receiver circuit is disclosed which includes an ISI measurement circuit and a mechanism for varying the selected FFT window position, in order to minimise the amount of ISI. The window is selected so as to minimise the amount of energy/power in unused carriers of the FFT.

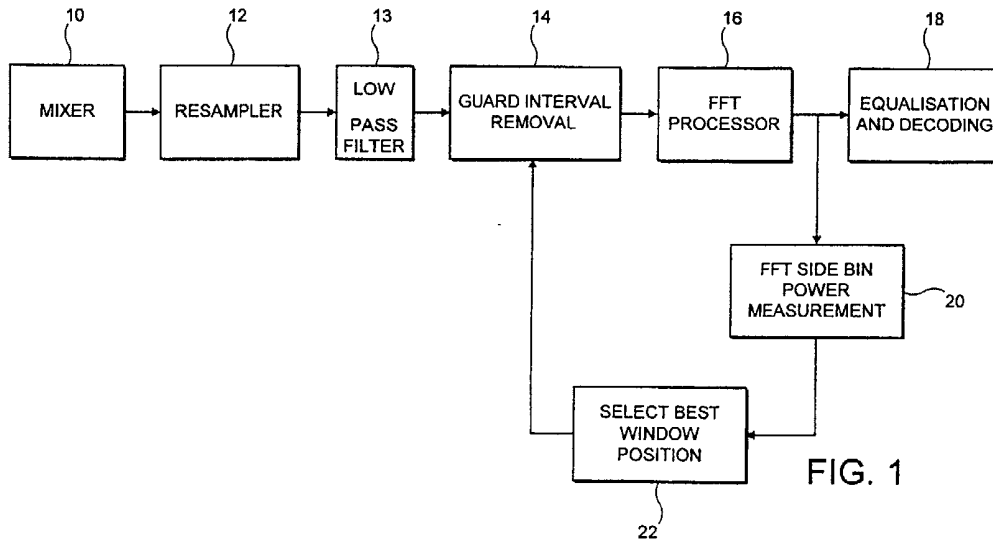

FIG. 1

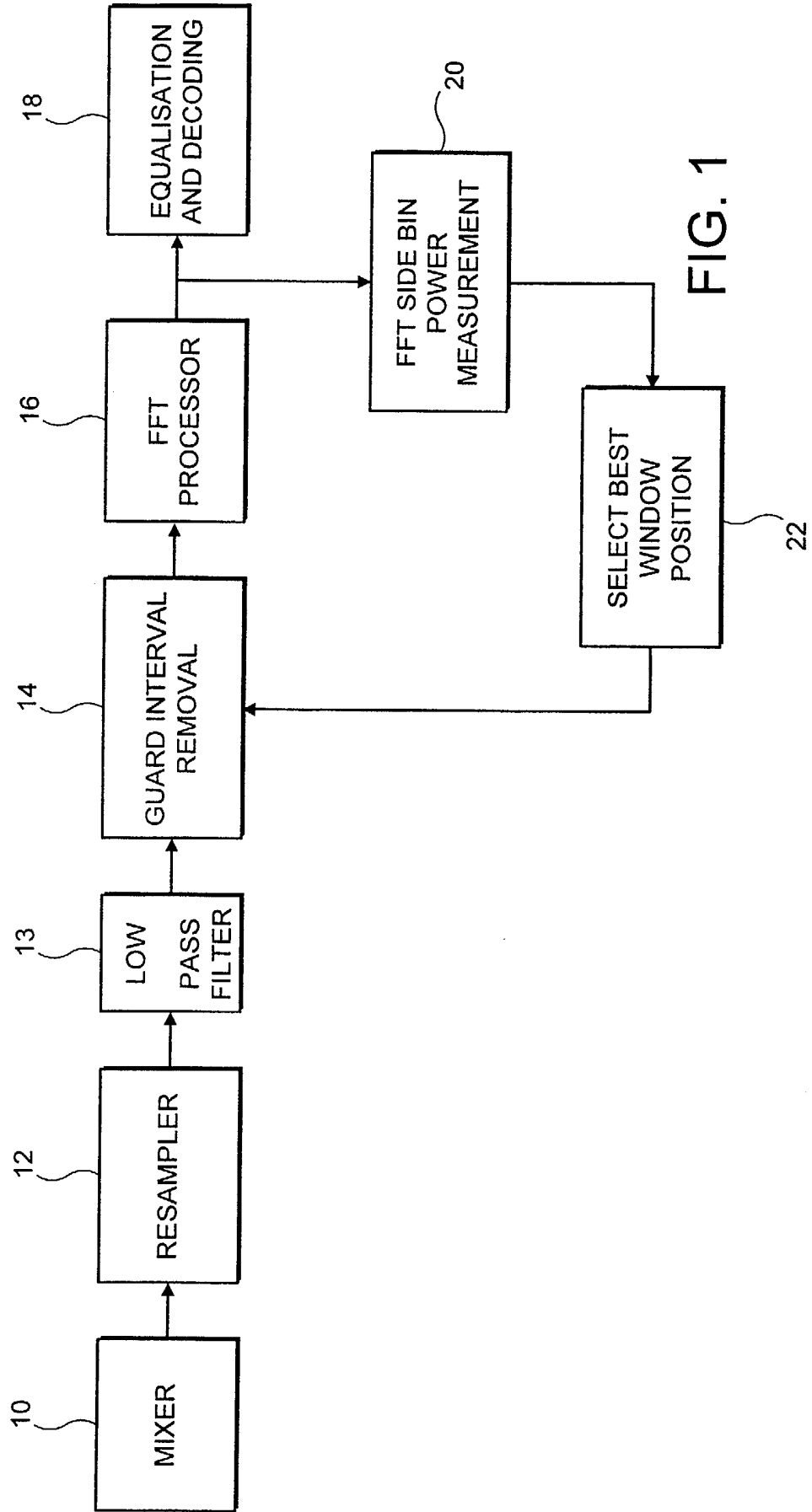

FIG. 1

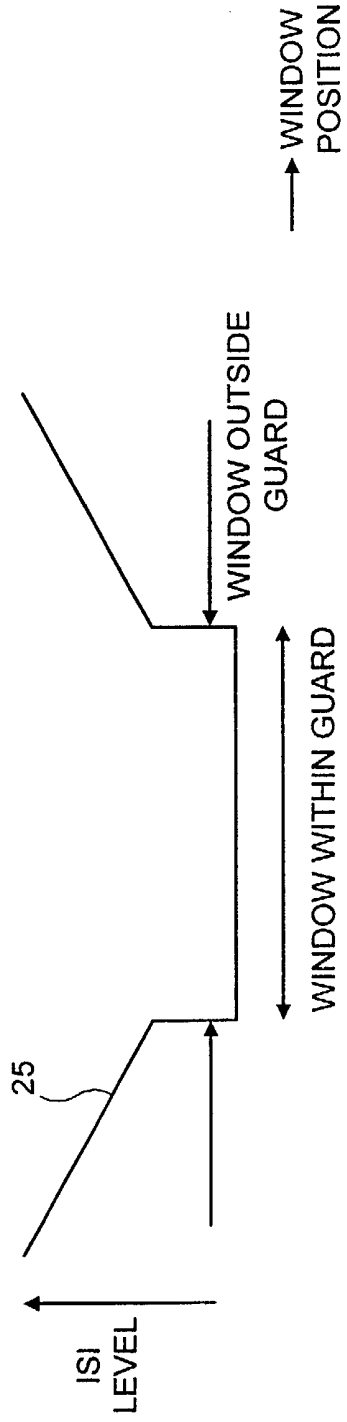

FIG. 2

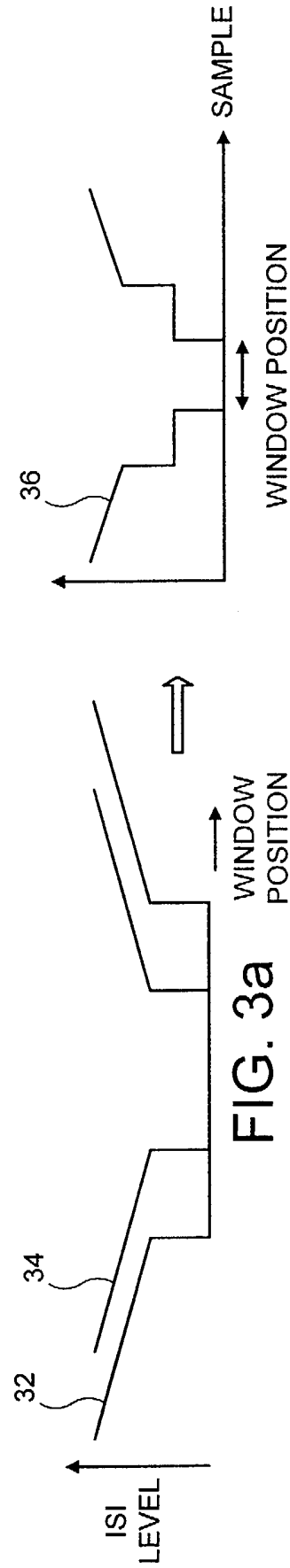

FIG. 3a

FIG. 3b

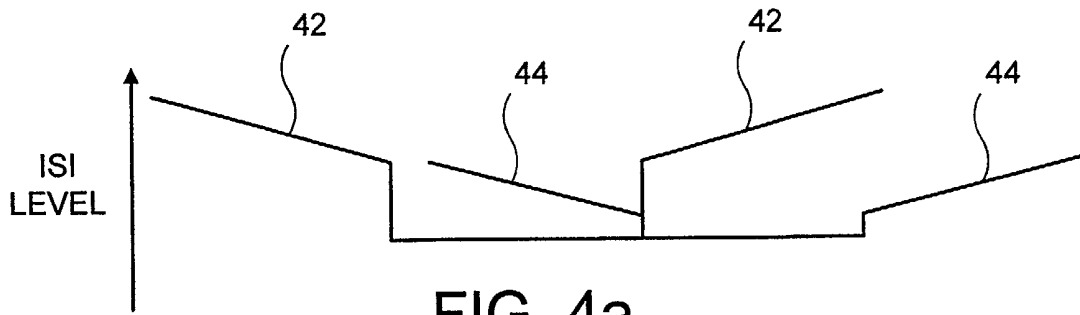

FIG. 4a

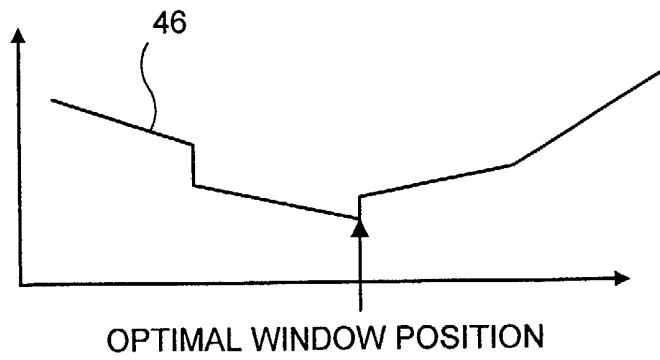

FIG. 4b

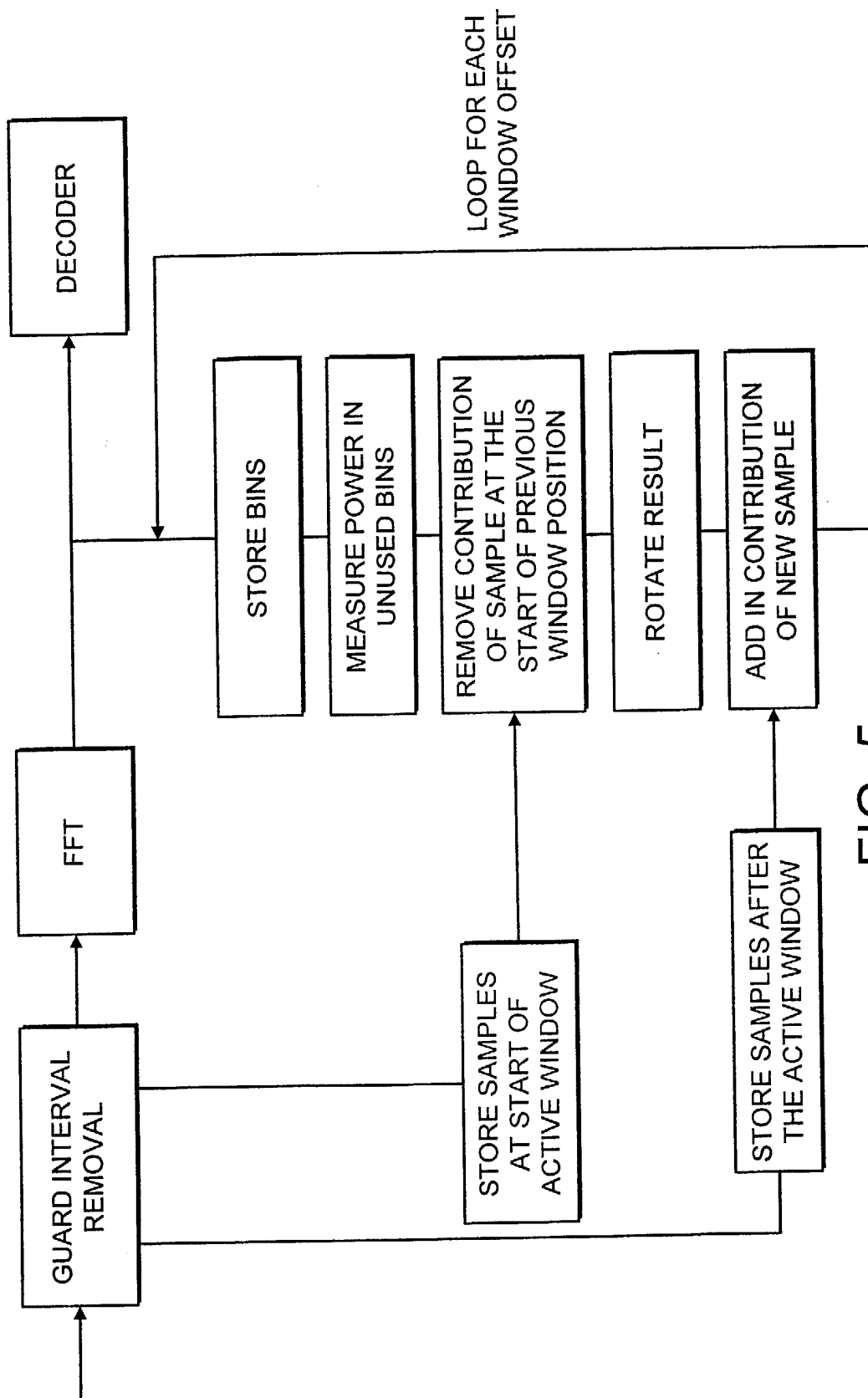

FIG. 5

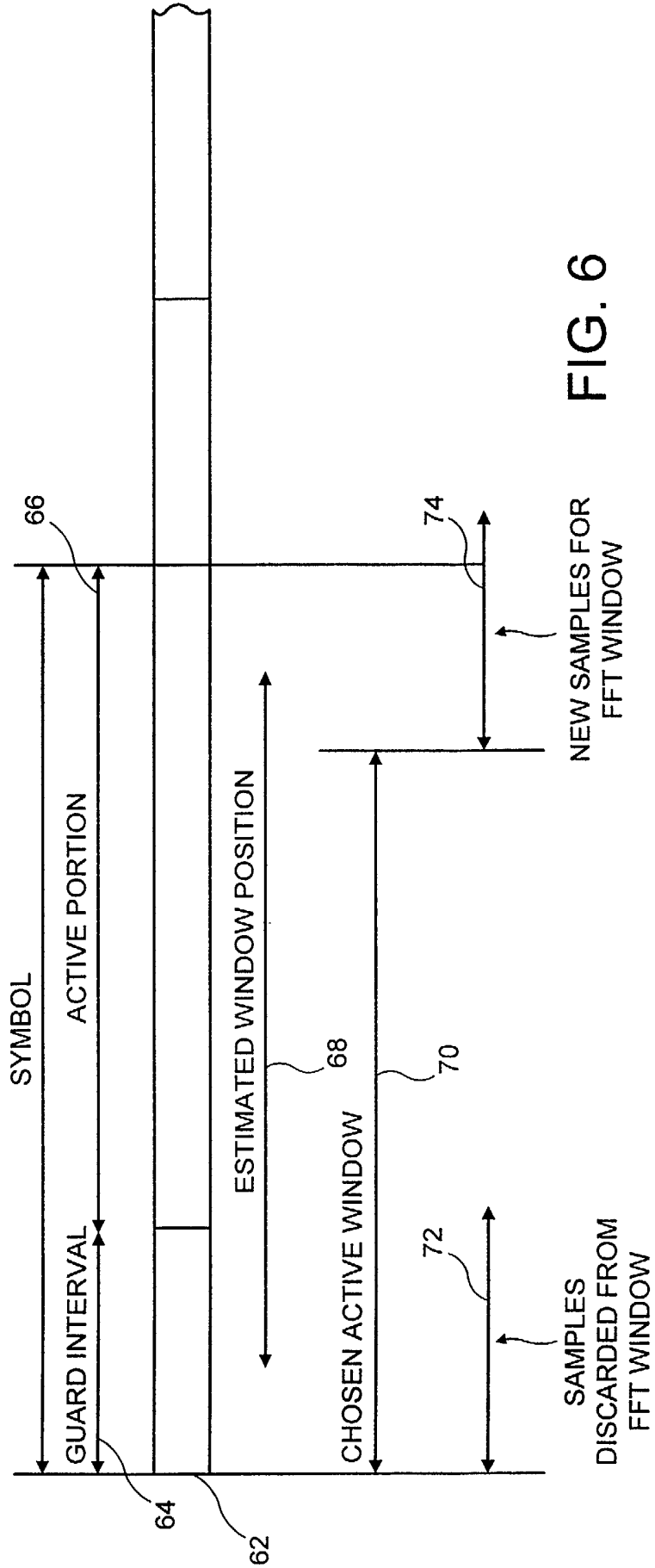

FIG. 6

RECEIVER CIRCUITTECHNICAL FIELD OF THE INVENTION

This invention relates to a receiver, for use where the transmitted signal is modulated using COFDM (Coded Orthogonal Frequency Division Multiplexing), and in particular to a receiver for broadcast digital terrestrial television signals, .

BACKGROUND OF THE INVENTION

The European DVB-T (Digital Video Broadcasting - Terrestrial) standard for digital terrestrial television (DTT) uses Coded Orthogonal Frequency Division Multiplexing (COFDM) of transmitted signal, which are therefore grouped into blocks and frames.

After reception in the television receiver the signals are sampled for example using a resampler, and are mixed down to baseband. The start of each active symbol is found, and then the active symbols are applied to an Fast Fourier Transform (FFT) processor for extraction of the modulated signals.

It is necessary to transmit the DTT signals over transmission paths which are of uncertain quality. In particular the area close to the transmission path may include objects such as tall buildings, which cause echoes. That is, a signal may be received at a receiver multiple times, once on a direct path from the transmitter, and then, after short delays, as echoes.

Further, the DVB-T standard may be used in a single frequency network of transmitters. That is, a single receiver can receive the same signal on the same frequency, from multiple transmitters.

As is well known, these factors can cause inter-symbol interference (ISI) in the receiver. To minimise this problem, DVB-T COFDM symbols include a cyclic prefix guard interval to each active symbol. Specifically a portion of each active symbol is repeated before that active symbol.

The echoes may be of various amplitudes and delays, and the first received component may not be the strongest. Also the delay between the first received component and the last may be greater than the guard interval and thus some ISI may occur. For optimal demodulation performance, it is necessary to select a Fast Fourier Transform window that minimises the amount of ISI experienced.

SUMMARY OF THE INVENTION

According to a first aspect of the invention, there is provided a COFDM receiver circuit which includes an ISI measurement circuit and a mechanism for varying the selected FFT window position.

According to a second aspect of the invention, there is provided a method of varying an FFT window position to minimise the effects of ISI.

Thus, rather than attempting to detect the positions of echoes, and then deal with them, the invention advantageously seeks to minimise the effects of the echoes.

BRIEF DESCRIPTION OF DRAWINGS

Figure 1 is a schematic illustration of a part of a receiver circuit in accordance with the invention.

Figure 2 shows the power in unused carriers of a Fast Fourier Transform output for varying window positions, in a first case.

Figure 3 shows the power in unused carriers of a Fast Fourier Transform output for varying window positions, in a second case.

Figure 4 shows the power in unused carriers of a Fast Fourier Transform output for varying window positions, in a third case.

Figure 5 illustrates a process in accordance with an embodiment of the invention.

Figure 6 illustrates a stage in the process of Figure 5.

DETAILED DESCRIPTION OF PREFERRED EMBODIMENTS

Figure 1 shows a section of a receiver circuit relevant to the present invention.

Typically, in the exemplary case of a digital terrestrial television signal receiver for example receiving signals using the DVB-T standard with Coded Orthogonal Frequency Division Multiplexing (COFDM), the receiver will include an antenna (not shown), and a tuner (not shown) for receiving the signals and down converting to an intermediate frequency.

The receiver further includes a further mixer stage 10 for down-converting to baseband, and a resampler 12, for obtaining digital samples synchronised to the incoming signal. The down-conversion mixer frequency and resampler rate are locked to the incoming IF frequency and transmitter sample rate respectively. Output signals from the resampler 12 are filtered by a low pass filter 13 to removed unwanted mixer components and then supplied to a guard interval removal block 14 which removes the cyclic components which precede each active symbol. The output of the guard interval removal block 14 is supplied to an FFT processor 16 which outputs to an equalisation and decoding block 18 and also an FFT side bin power measurement block 20, which will be described further below. The result is supplied to a window position selection block 22, also to be described further below.

The equalisation and decoding block 18 compensates for the channel and recovers the originally transmitted bit stream, in a generally conventional way.

Specifically, in this example, the output of the FFT processor 16 has 2048 carriers of which only 1705 (in the case of DVB-T 2k mode) carry transmitted information. The lowpass filter 13, will reduce to a negligible level energy in the 343 unused carriers

which are divided essentially equally either side of the used carriers. In the absence of echoes, a correctly positioned FFT window will result in no additional energy in the unused carrier positions. In fact, the start of the FFT window position can be placed anywhere within the guard interval (cyclic prefix) and this will still be the case. However, if the start of the FFT window position is placed outside the guard interval, this is no longer true, since the window now encompasses samples from the adjacent symbol, and so ISI results. These ISI samples create impulse noise on the wanted window. The frequency spectrum of each of these impulses is of constant amplitude, and so they add constant energy in all the bins, including previously empty bins. Therefore, the energy in these bins is a measure of the amount of ISI.

For example, if the start of the FFT window position is placed one sample outside the guard interval, this is equivalent to a single impulse of noise which results in a constant power level across all the FFT output carriers. Further displacement outside the guard interval results in increased noise levels across all carriers.

Figure 2 shows the variation in the ISI level as a function of offset in the FFT window position.

If echoes are present then the variation of ISI level as a function of offset in the FFT window position can be obtained approximately by superposition.

Figure 3 shows the case in which there is one additional echo, of an amplitude equal to that of the main signal, whose delay is within the guard interval length. Figure 3a shows the respective ISI levels 32, 34 resulting from the main signal and the echo. Figure 3b then shows the resulting overall ISI level 36. The optimal FFT window position as marked would then be

such that it produces zero ISI.

Figure 4 shows the case of an additional echo of smaller amplitude than the main signal, but with a delay greater than the Guard Interval length. Figure 4a shows the respective ISI levels 42, 44 resulting from the main signal and the echo. Figure 4b then shows the resulting overall ISI level 46. In this case there exists one position with minimum but not zero ISI.

The level of ISI can be determined by the energy that exists in some or all of the unused carrier locations by the FFT side bin power measurement block 20. Although it may be optimal to calculate the power in all of the unused carriers, other methods are also possible. For example, it may be advantageous to exclude those unused carriers closest to the active window, in order to avoid the effects of the active portion bleeding through into the unused carriers. As another example, it may be advantageous to measure the power in unused carriers to only one side of the window.

In order to obtain the information contained in the graphs shown in Figures 2, 3 and 4 one possibility would be, for each COFDM symbol, to perform an FFT for a range of offsets of the FFT window position, the range preferably being at least twice the guard interval. Then this would have to be averaged over a number of COFDM symbols to obtain a graph with suitable accuracy. This represents a very significant overhead of processing.

A preferred method of calculation in accordance with the invention is shown in Figure 5. There are a number of possible variants of the scheme shown, but all embody the present invention.

First, an initial estimate of the FFT window location is made by using one of a number of standard

methods. The system further specifies a range of possible offsets from that estimated position, over which ISI measurements are to be taken, so that the optimum position can be selected from within that range. The range is preferably chosen with reference to the maximum expected delay time of a significant echo. Thus, the range is preferably chosen with reference to knowledge about the system in which the receiver is to be used. For example, the range may be twice the guard interval.

Figure 6 shows one symbol period of a received signal. As is well known, one symbol 62 includes a guard interval 64 and an active portion 66. Figure 6 also shows the estimated window position 68.

A first chosen active window 70 is then defined, the first chosen active window 70 being offset from the estimated window position 68, being earlier by half the total range of offsets whose ISI is to be measured.

The system also stores the values of a number of samples 72 at the start of the chosen active window 70, and stores the values of the same number of samples 74 after the end of the chosen active window 70.

For the first chosen active window position, the FFT is performed in the usual manner, the carrier output values are stored, and the power in some or all of the unused carriers is measured.

In accordance with this preferred embodiment of the invention, the FFT calculation is not simply repeated for other window positions, but the algorithm calculates each successive advance in position in an iterative manner, sample by sample.

Thus, the FFT output for an advance in FFT window position of one sample is repeatedly calculated, in the following manner. First the frequency contribution of the earliest sample of the previous FFT window position, that is, the first of the samples 72, is

subtracted from all of carriers of the previous FFT output. Then the phase of each output carrier of the previous FFT is rotated by an amount equivalent to having advanced the FFT window position by one sample. Then, the frequency contribution of the next new sample after the end of the FFT window, that is, the first of the samples 74, is added to each output carrier of the previous FFT as if it had been calculated as part of a full FFT. The power measurement, and hence the ISI measurement, can then be made for the next offset FFT window position. This algorithm is successively applied, sample by sample, for the range of offsets required for each symbol, until the offset window position includes all of the samples 74 and none of the samples 72. The results can then be averaged over a number of symbols for greater accuracy.

The result of adding the powers of some or all of the unused carriers for each FFT window position is then stored and can be used to produce a graph similar to those shown in Figures 2, 3 and 4.

Having calculated a graph of the sort shown in Figures 2, 3 and 4, the optimal window position may be found, and subsequently tracked with feedback to the guard interval removal block. When the graph resembles that of Figure 3, in the sense that there is a range of window positions which produce apparently equally good ISI values, a further selection can be made to determine the optimal position. For example, a position may be chosen which improves the ease with which the resultant signal may be handled in the succeeding equalisation block, based on expected pattern of echoes. For example, if the environment is such that rapidly arriving pre-echoes are a possibility, the optimal window position may be near the right-hand end of a range of window positions which produce apparently equally good ISI values, in order

that the equalisation block can most easily deal with pre-echoes.

There is thus described a COFDM receiver, and a method of operation thereof, which allow optimal selection of a FFT window position.

5

CLAIMS

1. A method of processing a received COFDM signal, the method comprising:

5 selecting a position of a FFT window, in order to minimise the effects of inter-symbol interference in the FFT output.

2. A method of processing a received signal, the received signal made up of symbols, each symbol comprising an active portion and a guard portion, the method comprising:

10

removing the guard portion from each symbol to leave the active portion; and

applying a Fast Fourier Transform (FFT) to the active portion, the FFT processor having a number of carriers greater than the number of samples in the active portion; and further comprising:

15

selecting a position of a FFT window, in order to minimise the effects of inter-symbol interference in the FFT output.

20

3. A method of processing a received signal, the received signal made up of symbols, each symbol comprising an active portion and a guard portion, the method comprising:

25

removing the guard portion from each symbol to leave the active portion; and

applying a Fast Fourier Transform (FFT) to the active portion, the FFT processor having a number of carriers greater than the number of samples in the active portion; and further comprising:

30

selecting a position of a FFT window, in order to minimise the amount of energy in carrier locations of the FFT processor outside the active portion.

4. A method of processing a received signal, the received signal made up of symbols, each symbol comprising an active portion and a guard portion, the method comprising:

35

removing the guard portion from each symbol to leave the active portion; and further comprising:

selecting a first Fast Fourier Transform (FFT) window position;

5 applying a FFT to the active portion, the FFT processor having a number of carriers greater than the number of samples in the active portion, and the FFT window being at the selected first FFT window position;

10 calculating a power in unused carriers of the FFT; repeatedly applying an FFT to the active portion, the FFT window being at further FFT window positions, and calculating the power in unused carriers of the FFT with the FFT window being at the further FFT window positions; and

15 selecting an active position of the FFT window, in order to minimise said power in unused carriers of the FFT.

5. A method of processing a received signal, the received signal made up of symbols, each symbol comprising an active portion and a guard portion, the method comprising:

20 removing the guard portion from each symbol to leave the active portion; and further comprising:

25 selecting a first Fast Fourier Transform (FFT) window position;

storing the values of samples within the window at a first end of the first window position;

storing the values of samples outside the window at a second end of the first window position;

30 applying a FFT to the active portion, the FFT processor having a number of carriers greater than the number of samples in the active portion, and the FFT window being at the selected first FFT window position;

calculating a power in unused carriers of the FFT;

35 (a) discarding a contribution to said power from a sample at the first end of the window;

(b) including a contribution to said power from a sample at the second end of the window; and

(c) calculating a power in unused carriers of the FFT after steps (a) and (b);

5 repeating steps (a) - (c);

selecting an active position of the FFT window, in order to minimise said power in unused carriers of the FFT.

10 6. A COFDM receiver, comprising a FFT processor, and means for selecting a position of a FFT window, in order to minimise the effects of inter-symbol interference in the FFT output.



INVESTOR IN PEOPLE

Application No: GB 0006217.4
Claims searched: 1-6

Examiner: Stephen Smith
Date of search: 28 November 2001

Patents Act 1977 Search Report under Section 17

Databases searched:

UK Patent Office collections, including GB, EP, WO & US patent specifications, in:

UK Cl (Ed.S): H4P(PAN, PAX)

Int Cl (Ed.7): H04L 27/26

Other: ONLINE: EPODOC, JAPIO, WPI

Documents considered to be relevant:

| Category | Identity of document and relevant passage | Relevant to claims |
|----------|--|--------------------|
| X, E | EP 1063824 A2 (MATSUSHITA) lines 12-58 of column 3 | 1, 2, 6 |
| X | US 5848107 (PHILIPS) lines 13-52 of column 2 | 1, 2, 6 |
| A | GB 2346052 A (SAMSUNG) | |
| A | EP 0853410 A2 (SAMSUNG) | |
| A | WO 99/12305 A1 (SAMSUNG) | |

X Document indicating lack of novelty or inventive step
 Y Document indicating lack of inventive step if combined with one or more other documents of same category.

& Member of the same patent family

A Document indicating technological background and/or state of the art.
 P Document published on or after the declared priority date but before the filing date of this invention.
 E Patent document published on or after, but with priority date earlier than, the filing date of this application.