

[72] Inventor **Vincent Marasco**  
 1364 N. Western Ave., Los Angeles, Calif.  
 90027

[21] Appl. No. **701,613**

[22] Filed **Jan. 30, 1968**

[45] Patented **July 6, 1971**

Continuation-in-part of application Ser. No. 530,315, Feb. 28, 1966, now abandoned.

[56] **References Cited**

UNITED STATES PATENTS			
2,443,153	6/1948	Wells.....	74/520
2,595,579	5/1952	Hawkins.....	81/379
2,997,903	8/1961	Rommel et al.....	81/379 X
3,192,804	6/1965	Petersen et al. ....	81/370 X
FOREIGN PATENTS			
114,600	7/1945	Sweden .....	81/380

Primary Examiner—Robert C. Riordon  
 Assistant Examiner—Roscoe V. Parker, Jr.  
 Attorney—Donald Diamond

[54] **PLIERS WITH ADJUSTABLE TOGGLE LOCK**  
 11 Claims, 9 Drawing Figs.

[52] U.S. Cl. .... 81/372

[51] Int. Cl. .... B25b 7/12

[50] Field of Search ..... 81/367-  
 —380, 363, 329; 269/201, 228; 30/251, 184, 190;  
 74/106, 520

**ABSTRACT:** Pliers with a toggle-type grip lock have a large diameter adjusting screw with a high helix angle on the thread to enable the operator to make a quick, easy adjustment of the jaw spacing. The contact between the end of the screw and the toggle is eccentric on the screw in order to lock the adjustment screw against "overhauling" or backing off. Adjustable means regulate movement of the toggle toward open position and thus the gripping pressure when the jaws are closed.

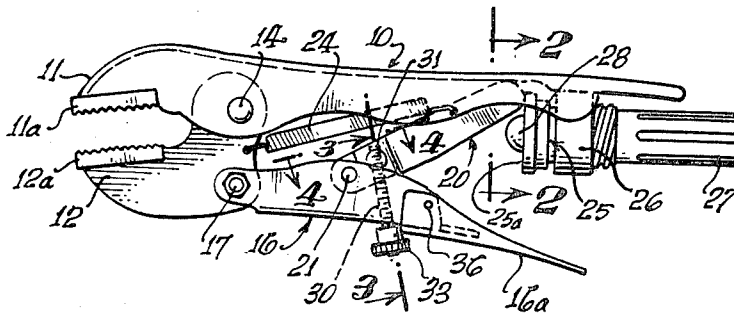

Fig. 1.

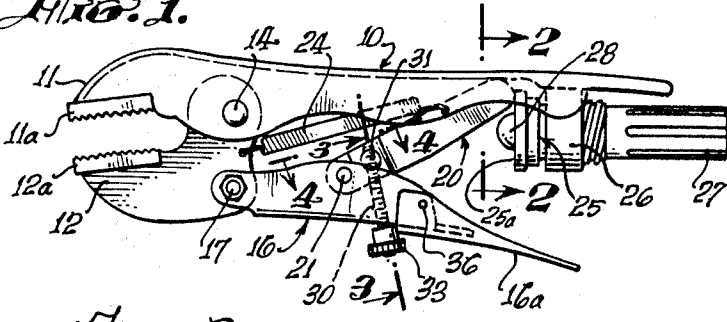

Fig. 2.

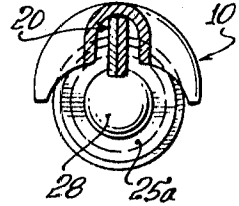

Fig. 6.

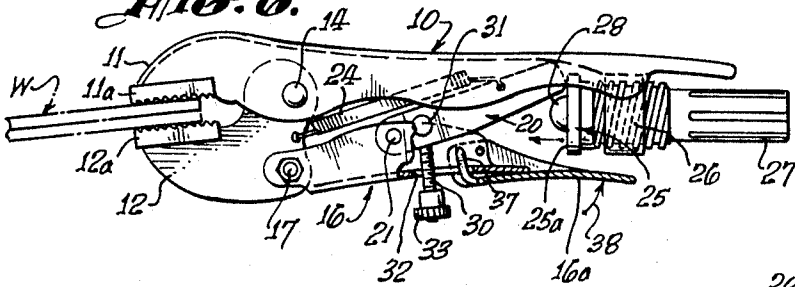

Fig. 5.

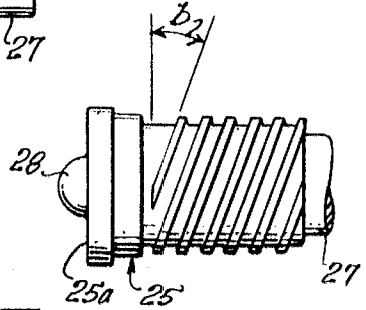

Fig. 7.

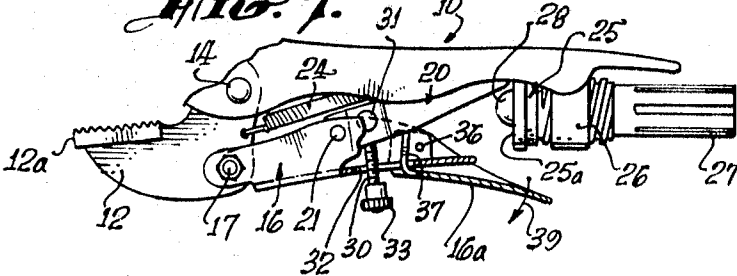

Fig. 3.

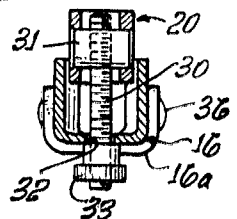

Fig. 8.

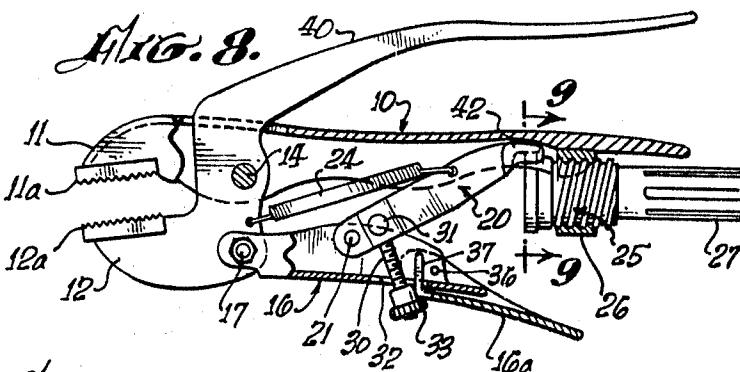

Fig. 4.

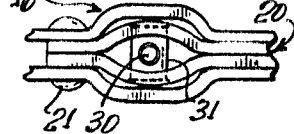
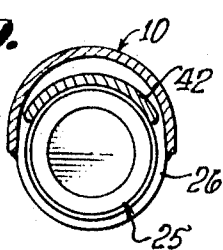

Fig. 9.



INVENTOR  
VINCENT MARASCO,

By *Ernest Knight & Rodgers*  
ATTORNEYS.

## PLIERS WITH ADJUSTABLE TOGGLE LOCK

### CROSS-REFERENCE TO RELATED APPLICATION

This application is a continuation-in-part of my copending application of the same title filed Feb. 28, 1966, Ser. No. 530,315, now abandoned.

### BACKGROUND OF THE INVENTION

The present invention relates generally to handtools, and more particularly to pliers or wrenches with an adjustable toggle lock by which the jaws can be locked in gripping position. The locking mechanism gives a viselike grip, and tools of this type are, accordingly, sometimes referred to as vise wrenches.

Pliers or wrenches of this type require adjustment of the initial jaw opening to obtain the proper grip, which is in part by the spacing of the jaws and in part by the jaw travel produced by the toggle-locking mechanism. In known designs of such handtools, this can be an awkward and frustrating procedure since the tool must be held in one hand to close the jaws while the other hand is used to adjust the toggle-locking mechanism. If the work is not self-supporting, it also must be held firmly by the tool during the adjusting operation; and the worker feels that he needs three hands in order to hold the workpiece with one hand while simultaneously manipulating the tool and securing the proper toggle adjustment.

In addition to being an awkward procedure with known tools, this adjusting can sometimes be time consuming. While the time involved in any one adjustment is small, yet in shops where repeated operations are performed in which different adjustments are required each time, as, for example, in holding together pieces of metal that are to be welded or otherwise operated on, the accumulated time involved in many adjustments of the tool is substantial. Even apart from the value of this time, any workman appreciates the convenience of being able to effect an adjustment of this character with maximum ease and minimum inconvenience, or delay.

Hence, it is a general object of the present invention to provide a novel and improved design for a tool, such as pliers or a wrench, having a toggle-locking mechanism, which tool is adjustable quickly, easily, and with a minimum of inconvenience to the worker to any particular workpiece.

It is a more particular object of the invention to provide a novel design for a tool of this character which permits the workman to preset the toggle lock for a given clamping force. This simplifies the operation of holding the workpiece and the tool with one hand and adjusting the initial jaw spacing with the other hand as required by the size of the work to be gripped.

### SUMMARY OF THE INVENTION

These and other objects of the present invention are embodied in a tool having an elongated, relatively stationary handle terminating in a stationary jaw, a movable jaw pivotally connected to the handle to cooperate with the stationary jaw to hold an article, and toggle means for locking the jaws in gripping position, such toggle means including an operating lever pivotally connected at its forward end to the movable jaw, a toggle link pivotally connected at the forward end thereof to the operating lever and extending longitudinally of the handle into engagement at its rear end with an adjusting screw mounted on the handle, and a tension spring connected between the movable jaw and the link. The improved toggle-adjusting mechanism comprises adjustable means limiting relative movement of the toggle link and operating mechanism away from locked position to regulate gripping pressure when the jaws are closed. The threaded toggle-adjusting screw rotatably mounted on the handle bears against the rear end of the toggle link, and, through the toggle mechanism, adjusts the initial jaw spacing to accommodate the work to be gripped. The screw preferably has a forward or leading face provided

with an annular area of planar configuration against which the rear end of the link bears permitting the screw to be turned while in contact with the rear end of the adjusting link, an outwardly extending central configuration on the screw assisting to hold the link in proper position.

The lead angle of the thread on the adjusting screw is greater than the friction angle between the screw thread and the handle, preferably being about 20° although it may be within a range of about 10° to about 25°. With a lead angle this large, the diameter of the screw is increased from the known sizes to about ¾ inch to 1 inch so that the full normal range of axial travel of the screw with relation to the adjusting link can be accomplished in substantially one complete turn of the adjusting screw.

### BRIEF DESCRIPTION OF THE DRAWING

How these objects and advantages of the present invention, as well as others not specifically mentioned herein, are attained will be more readily understood by reference to the following description and to the annexed drawing, in which:

FIG. 1 is a side elevation of a simplified form of the invention;

FIG. 2 is a fragmentary transverse section on line 2-2 of FIG. 1;

FIG. 3 is a section on line 3-3 in FIG. 1 through the toggle-adjusting means;

FIG. 4 is a fragmentary plan on line 4-4 of FIG. 1 showing the toggle-adjusting screw;

FIG. 5 is an enlarged view of the adjusting screw alone removed from the tool;

FIG. 6 is a side elevation similar to FIG. 1 showing the jaws in gripping position;

FIG. 7 is a fragmentary side elevation showing operation of the toggle-breaking lever;

FIG. 8 is a side elevation and section of a modified form of the invention in which the movable jaw is provided with a handle; and

FIG. 9 is a section on line 9-9 of FIG. 8.

### DESCRIPTION OF A PREFERRED EMBODIMENT

Referring now to the drawing, and particularly to FIGS. 1 to 6, it will be seen that the handtool of the present invention comprises an elongated handle member 10 at one end of which, herein referred to as the forward end, is a work-gripping jaw 11 which may have a pad 11a with a serrated gripping surface. Handle 10 and jaw 11 are referred to as the relatively stationary handle member and jaw for purposes of identification and because they are, in effect, the base members with respect to which the other components of the tool move. Handle 10 is channel-shaped in cross section (FIG. 2), as is well known in such tools, for much of its length.

Movable jaw 12 is pivotally connected at 14 to handle 10 and is provided with an article-gripping pad 12a which cooperates with pad 11a on jaw 11 to hold between them any suitable workpiece W which is being worked upon. Pads 11a and 12a are merely typical and may be omitted or changed.

FIG. 6 shows the work held between the jaws, the work W merely being typical of such items and not limitative upon the invention. Toggle means are provided for locking the two jaws in closed position to hold an article between them. Such toggle means includes the channel-shaped operating lever 16 which is pivotally connected at 17 at its forward end to movable jaw 12. The operating lever 16 extends rearwardly and parallel to the stationary handle 10 so that the two members can be grasped in one hand by an operator and moved toward one another about pivot 17.

The toggle means also includes toggle link 20 which is pivotally connected at its forward end at 21 to operating lever 16 at a position intermediate the ends of the operating lever and rearwardly of pivot 17. The other or rear end of toggle link 20 slidably engages handle 10, as also shown in FIGS. 2 and 6. Handle 10 being a channel-shaped member, the side

flanges of the channel restrain toggle link 20 from lateral movement while allowing complete freedom of the toggle link to slide backwards and forwards in contact with the inside surface of stationary handle 10.

A helical tension spring 24 is connected at its ends, respectively, to movable jaw 12 and to toggle link 20. The pull of the tension spring is in a direction to open jaws 11 and 12 and to push the toggle link 20 rearwardly along handle 10.

The position of toggle link 20, and consequently the spacing between jaws 11 and 12 when open under the pull of spring 24, is controlled by adjusting screw 25 which is an externally threaded member rotatably mounted in an internally threaded sleeve 26 which is secured to the underside of handle 10. In this position, the forward end face of adjusting screw 25 bears against the rear end surface of toggle link 20, this contact between the two members being maintained by the pull of spring 24. Adjusting screw 25 is preferably provided with a rearwardly extending knob or handle 27 by means of which the screw can be manually rotated by the operator to move the screw forwards and backwards relative to stationary handle 10.

Referring to FIG. 2, it will be seen that the forward face of screw 25 is provided with an annular area 25a which is smooth and lies substantially in a radial plane. The end of link 20 bears against this portion of screw 25, the point of contact of the link and the screw being eccentric with respect to the axis of rotation of the screw. It is preferable to provide adjusting screw 25 with a central projection 28 at its forward face 25a, surrounded by the flat area 25a, this projecting portion 28 serving to keep the end of toggle link 20 from dropping downwardly over the face of the screw.

Means are also provided extending between the operating lever and the link providing the relative movement of these two toggle members as they move away from the locked position of FIG. 6 to the released position of FIG. 1. This motion-limiting means comprises typically a screw 30 which is attached to link 20 by a swivel nut 31, shown in FIG. 4. Screw 30 extends through a slot 32 and beyond the lower surface of operating lever 16 where it has a knob 33 by which the screw is turned. Nut 31 has threads engaging screw 30 and the nut is pivotally mounted on link 20, allowing screw 30 to swing about the axis of swivel nut 31. By engagement with knob 33, the pivotal movement of operating lever 16 away from the article-gripping position of FIG. 6 toward the released position of FIG. 1 can be limited, as desired. Advantages of this will be described more fully later.

Once the toggle is in clamping position as in FIG. 6, it is difficult to release or "break" the toggle to release the article W. For this purpose, it is preferred to make operating lever 16 in two sections, the rear or auxiliary section 16a being pivotally connected at 36 to the forward section which extends rearwardly of the pivot (FIG. 6) to overlap the rear section. Both sections of the operating lever are typically channel-shaped; and the rear section has a central finger 37 that extends toward and is engageable with toggle link 20.

The rear section 16a of the lever has only a limited rocking motion about pivot 36. When rocked counterclockwise in FIG. 6, the inner or upper face of the rear section engages the rear end of the main section as in FIG. 6, with the result that the operating lever is, in effect, a single rigid member that closes the toggle when manual pressure, as by gripping in one's hand, is applied to move the operating lever toward the stationary handle in the direction of arrow 38.

In FIG. 5, there is shown a preferred embodiment of the adjusting screw. Because of the greater efficiency of square threads, they are preferably used; although a V-thread of conventional design may be employed, if desired. The thread employed preferably has a comparatively large lead angle, indicated at *b* in FIG. 5. This angle *b*, which is the angle between the thread and a plane at right angles to the axis of the screw, is large enough to be greater than the friction angle of the thread. Since the efficiency of the thread increases as the angle *b* increases, particularly up to a value of 20° a lead angle

of about 20° is preferred; but any angle within the range of about 10° to about 25° is considered to be satisfactory.

The coefficient of friction of dry steel on steel where both surfaces are clean and dry is about .4. However, under ordinary shop conditions, the threads on screw 25 and sleeve 26 are never ideally dry but are lubricated to a greater or lesser degree. Depending upon the type of lubrication, the coefficient of steel on steel between greasy or lubricated surfaces is generally given by handbooks as being in the range of .10—.16. The coefficient of friction may be reduced by good workmanship which produces smoother surfaces, extremely favorable lubricating conditions, and so on. However, this coefficient may be assumed under ordinary conditions generally to be about .16, or perhaps less.

Since the friction angle is the angle of which the tangent is equal to the coefficient of friction under given conditions, the friction angle for screw 25 has a range of 6° to 9° for a coefficient range of .10—.16 from which it may be concluded that the friction angle is generally less than 10°.

In known types of wrenches, the lead angle of the thread is much less than the friction angle of the materials. For example, in one well-known type of toggle wrench, the adjusting screw has a U.S. standard V-thread on a  $\frac{3}{8}$  inch bolt, the threads being 14 per inch. With such a thread, the lead angle is approximately 3½°. This is far less than the friction angle under even favorable lubricating conditions.

For the present wrench, it is preferred to use a thread lead angle in the range of 10° to 25° preferably about 20°. The advantage is that the large lead angle combined with the large diameter of the screw produces a high rate of advance of the adjusting screw. For example, assuming a lead angle of 20° on a screw thread having a diameter of .8 inch, the rate of advance of the adjusting screw is approximately .9 inch for each revolution. Since a range of travel of about one inch is all that is ordinarily necessary on a given sized handtool, this full range of travel can be accomplished with approximately one turn of the adjusting screw.

Since it is a general rule that a screw will back off or "overhaul" under an axial load when the friction angle is less than the lead angle, it would be expected that the adjusting screw designed as indicated above would not hold under the axial force imparted to it by toggle link 20. However, the eccentric location of the contact between the toggle link and the adjusting screw causes the threads on screw 25 to bind in sleeve 26 and as a result the screw does not back off under the force applied by toggle link 20. Any tendency for link 20 to turn with the screw and thus remove or reduce its thrust is prevented by the depending sides 10a of handle 10 bearing against the sides of link 20, as may be seen in FIG. 2.

The advantage of this construction is the ease and rapidity with which the jaws may be adjusted to the proper spacing to grip an article. First, adjusting screw 30 is set to obtain the proper closing movement of toggle members 16 and 20 to thereby produce the desired firmness of grip. The strength of grip or the clamping force applied to the work W increases as the closing movement of handle 16 increases, as is well known.

Next, the work to be gripped is placed between jaws 11 and 12 and the jaws are brought lightly into contact with the work by turning nut 25 and handle 27 to advance link 20 and ultimately jaw 12. Finally, by grasping handles 10 and 16, the latter is moved in the direction of arrow 38 to lock the toggle members as in FIG. 6, clamping work W between the jaws. The final movement of the jaws is obviously small but is produced by the toggle action.

The jaw movement produced by the toggle is, of course, a minimum with rigid materials, such as metals, and is greater with materials which may be indented or compressed, such as wood. The strength of the grip or clamping force desired determines the initial position for knob 33; and this is preset by the user prior to manipulating adjusting screw 25. When adjusting screw is extended, the toggle movement from released to locking position is increased. This also means the

movement of jaw 12 toward jaw 11 resulting from closing the toggle is also a maximum. At times a rigid article resists the jaw movement so effectively the toggle cannot be closed from a full open position. Then screw 30 is shortened by moving knob 33 closer to the toggle link 20. In this way, the final jaw travel and the gripping or clamping pressure can be adjusted.

When the jaws are to be released, the rear or auxiliary section 16a of the operating lever is rotated clockwise (as indicated by arrow 39 in FIG. 7) about pivot 36. This brings finger 37 against link 20, with pivot 36 between the finger and the force applied to lever section 16a. This rear section is now a lever with the downward force applied to the rear end thereof causing it to rock about the tip of finger 37 at the forward end as a fulcrum. Lever 16a thereby moves pivot 36, and also the rear end of the main section of lever 16, downwardly or clockwise around pivot 17. This enables the user to obtain a high mechanical advantage for breaking the toggle.

#### VARIATIONAL EMBODIMENT

The toggle mechanism and adjusting screw described above can be applied to pairs of relatively moveable jaws of various designs and arrangements. For example, in FIG. 8, there is shown the application of such elements to a tool which can also be operated in the manner of an ordinary pair of pliers. Such a tool is achieved by adding to the tool shown in FIGS. 1-6 a second handle 40 which is rigidly connected to the moveable jaw 12 and is disposed on the side of handle 10 away from toggle operating lever 16. Thus, rigid handle members 10 and 40 may be grasped to operate jaws 11 and 12 without locking them by means of the toggle mechanism.

Another change from the construction initially described, but which may be used therein, is shown especially in FIG. 9. The rear end of link 20 is provided with an arcuate flange 42 which rides above the forward end of screw 25. This section of the screw, as before, has a smooth circumferential surface that turns freely under flange 42. This flange holds link in position against screw 25 and so the central protuberance 28 may be omitted in this embodiment.

Various other changes may be made in the jaw arrangement. For example, the gripping pads can be pivoted on each of the jaw carrying members; or one of the jaws can be mounted to slide with respect to the jaw carrying member in order to increase the range of opening between the jaws and, therefore, increase the range of sizes of articles which can be gripped.

From the foregoing description, it will be apparent that various changes may be made in the exact design and detailed arrangement of the parts constituting the present invention without departing from the spirit and scope thereof. Accordingly, it is to be understood that the foregoing description is considered as being illustrative of, rather than limitative upon, the invention as defined by the appended claims.

I claim:

1. A handtool of the type described with a toggle lock, comprising:

an elongated, relatively stationary handle having a stationary jaw at the forward end thereof;

a movable jaw pivotally connected to the handle to cooperate with the first jaw for holding an article; toggle means locking the jaws in article-holding position, including

an operating lever pivotally connected at the forward end thereof to the movable jaw,

a toggle link pivotally connected at the forward end to the operating lever and extending longitudinally of and slidably engaging the handle,

and a tension spring connected between the movable jaw

and the link;

and a threaded adjusting screw rotatably mounted on the handle to bear against the rear end of the toggle link to position the link relative to the handle, the lead angle of the thread being greater than the friction angle between lubricated surfaces on the screw thread and on the handle,

said link engaging the adjusting screw at a single location eccentrically with respect to the axis of rotation of the screw.

2. A handtool as in claim 1 in which the adjusting screw has a forward face provided with a planar area of annular configuration against which the rear end of the link bears.

3. A handtool as in claim 1 which also includes means extending between the operating lever and the link limiting relative movement of the lever and the link away from locked position.

4. A handtool as in claim 1 in which the lead angle of the thread on the adjusting screw is between about 10° and about 25°.

5. A handtool as in claim 1 in which the lead angle of the thread on the adjusting screw is about 20°.

6. A handtool as in claim 1 in which the adjusting screw advances about one inch per revolution.

7. A handtool as in claim 1 which also includes a second handle rigidly connected to the movable jaw and disposed on the side of the relatively stationary handle remote from the operating lever.

8. A handtool as in claim 7 in which the lead angle of the thread on the adjusting screw is between about 10° and about 25°.

9. A handtool as in claim 7, which also includes means extending between the operating lever and the link limiting relative movement of the lever and the link away from locked position.

10. A handtool of the type described with a toggle lock, comprising:

an elongated, relatively stationary handle having a stationary jaw at the forward end thereof;

a movable jaw pivotally connected to the handle to cooperate with the first jaw for holding an article; toggle means locking the jaws in article-holding position, including

an operating lever pivotally connected at the forward end thereof to the movable jaw,

a toggle link pivotally connected at the forward end to the operating lever and extending longitudinally of and slidably engaging the handle,

and a tension spring connected between the movable jaw and the link exerting a force in a direction to open the jaws and to move the lever and link of the toggle means away from a locked position;

and a threaded adjusting screw rotatably mounted on the handle to bear against the rear end of the toggle link to position the link relative to the handle, and thereby to move the jaws toward and away from each other, the lead angle of the thread being greater than the friction angle between lubricated surfaces on the screw thread and on the handle;

and adjustable means extending between the operating lever and the link limiting relative movement of the lever and the link away from locked position in response to force applied by said spring.

11. A handtool as in claim 10 in which the last mentioned means includes a screw threadedly engaged by a nut mounted pivotally on the toggle link.