

M. E. DONALLY.
BOTTLING APPARATUS.

No. 500,866.

Patented July 4, 1893.

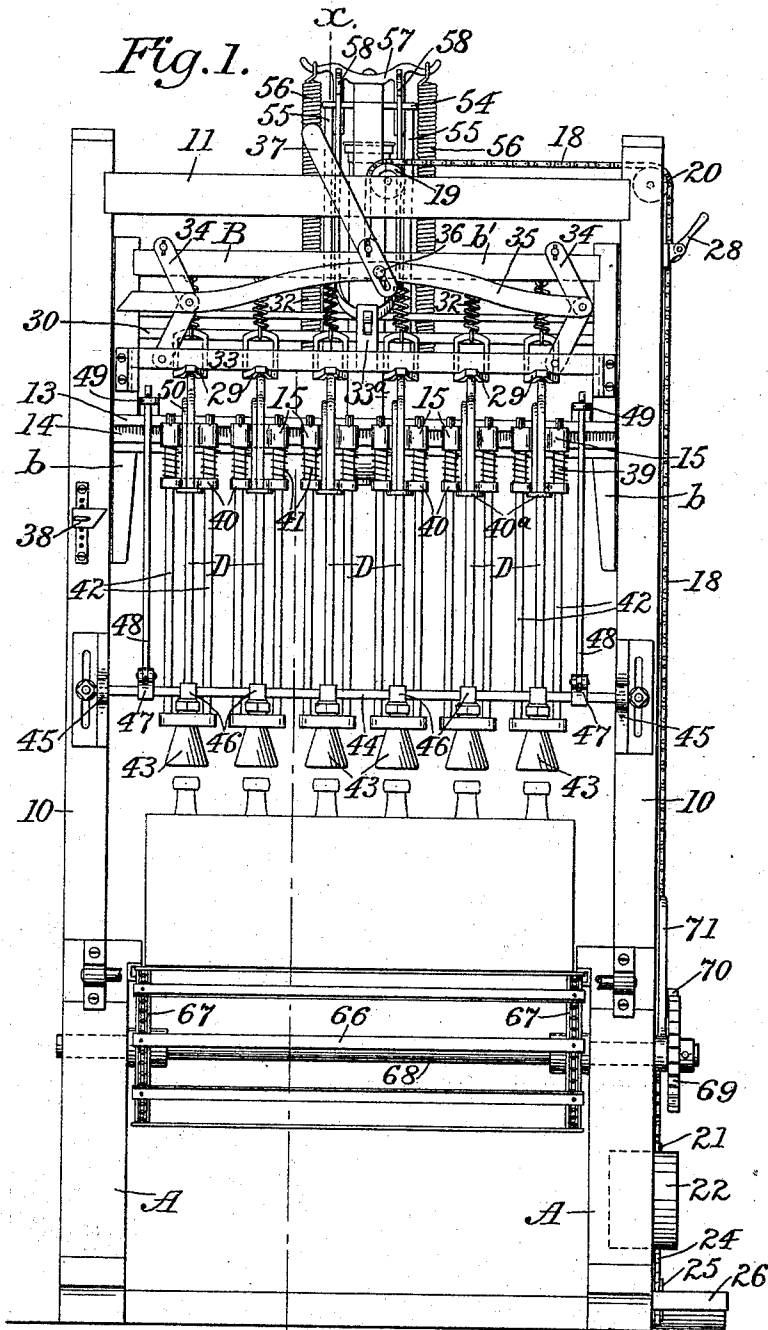

Attest:
A. A. Jester.
A. Lidden.

Inventor.
Melvin E. Donally
by William B. Greeley
Atty.

M. E. DONALLY.
BOTTLING APPARATUS.

No. 500,866.

Patented July 4, 1893.

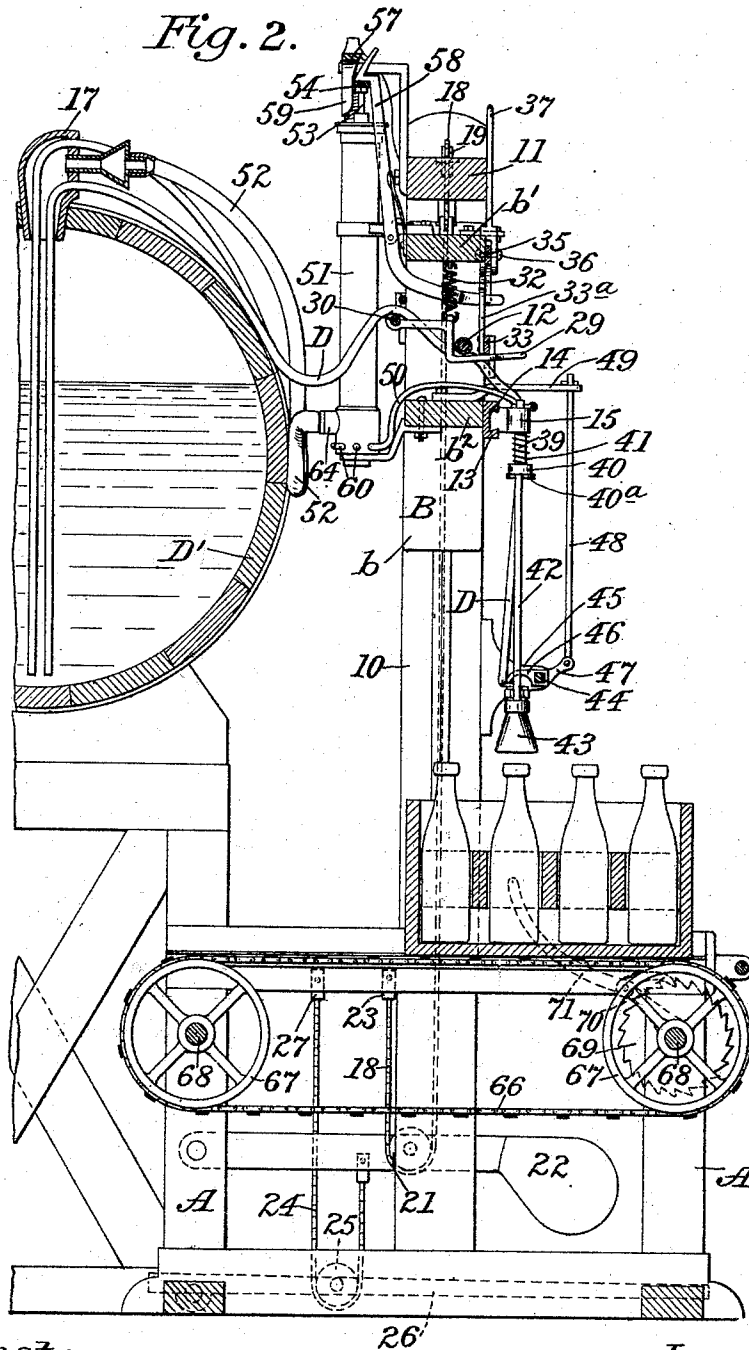

Attest:

A. N. Jesbora
A. Chadd

Inventor:

Melvin E. Donally
by William O. Greeley
Att'y.

M. E. DONALLY.
BOTTLING APPARATUS.

No. 500,866.

Patented July 4, 1893.

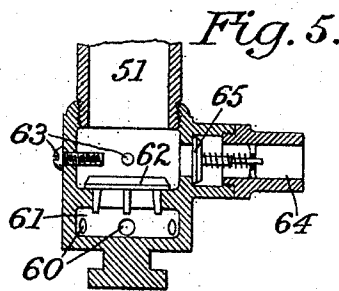
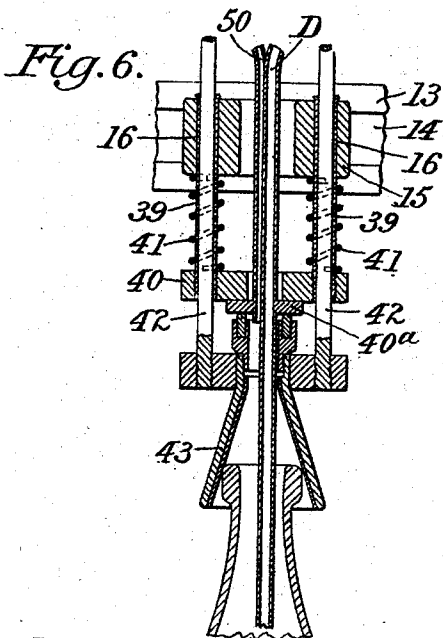
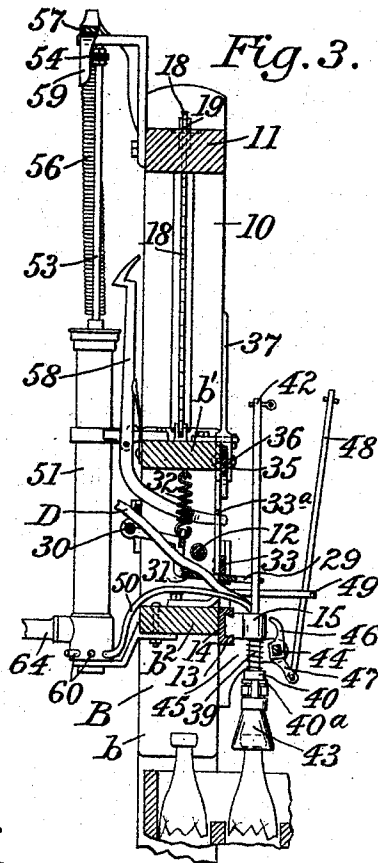
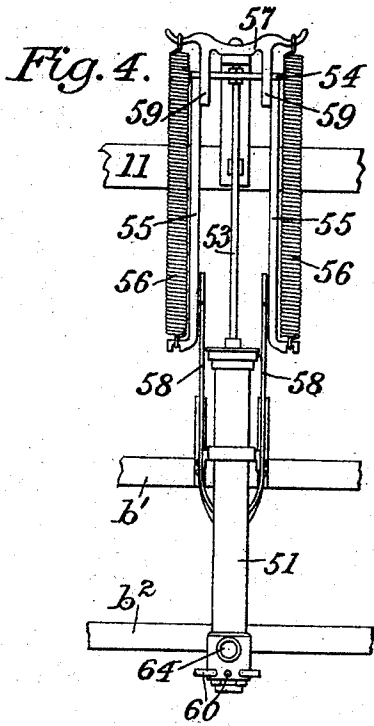

Attest:

A. N. Jester
A. Lhader

Inventor:
Melvin E. Donally
by *William D. Greeley*
Att'y.

UNITED STATES PATENT OFFICE.

MELVIN E. DONALLY, OF NEW YORK, N. Y.

BOTTLING APPARATUS.

SPECIFICATION forming part of Letters Patent No. 500,866, dated July 4, 1893.

Application filed September 22, 1892. Serial No. 446,580. (No model.)

To all whom it may concern:

Be it known that I, MELVIN E. DONALLY, a subject of the Queen of Great Britain, residing at New York, in the county and State of New York, have invented certain new and useful Improvements in Bottling Apparatus; and I do hereby declare that the following is a full and exact description thereof, reference being had to the accompanying drawings, and to the letters and figures of reference marked thereon, making a part of this specification.

My invention relates to machines for bottling beer or other liquids rapidly and has for its object to improve the construction of such machines in several particulars and especially to add means whereby the pressure on the liquid in the supply cask or reservoir may be increased as desired or maintained without diminution during the operation of the apparatus, and means whereby the air may be withdrawn from the bottles as the liquid flows into the same, thereby not only increasing the rapidity with which the bottles are filled but making it possible, in case of excessive foaming, to withdraw the foam from the bottles and return it to the cask or reservoir without removing the bottles from the filling machine.

Other novel features will be particularly pointed out hereinafter.

In the accompanying drawings: Figure 1 is a front view of the complete machine. Fig. 2 is a vertical section on the line $x-x$ of Fig. 1. Fig. 3 is a view of the upper part of the machine similar to Fig. 2 but showing certain parts in different positions. Fig. 4 is a view of the pump and its attachments from the rear, the parts being in the same position as in Fig. 3. Fig. 5 is a detail section on a larger scale of the lower end of the pump cylinder showing the arrangement of the valves. Fig. 6 is a detail section on a larger scale of one of the bottle-covering caps and its associated parts.

The frame of the machine consists of a base-section A, upon which standards 10 are secured, one at each side, the said standards being provided on their inner faces with channels adapted to receive tongues formed on the sides of a frame or carrier B, which is adapted to slide vertically in the ways so formed.

The standards of the fixed frame are connected at their upper ends by a cross beam or bar 11.

The movable frame B ordinarily comprises two side pieces b , united by an upper cross-bar b' and a lower cross-bar b^2 , while a rod 12 extends horizontally from one side piece to the other between the two cross-bars. A plate 13 is secured to the front face of the lower beam b^2 of the sliding frame, and upon the plate a slideway 14 is formed, in which a number of head-blocks 15 are fitted. The head-blocks are arranged at suitable intervals apart and are provided with vertical apertures 16, extending through from top to bottom, one of said apertures being located near each end, as shown in Fig. 6. The body of each block is further provided with a vertical central recess.

The central recesses of the head-blocks are adapted for the reception of a series of flexible filling-tubes D, which pass rearward under the rod 12. The tubes at their rear ends are passed through apertures formed in a bung 17, which is adapted to be driven into the bung-hole of the closed reservoir or cask D' to be emptied, and extends some distance below the bottom of the bung, so that when the bung is in position said tubes reach practically to the lower side of the cask, as shown in Fig. 2.

The frame or carrier B is partly counter-balanced and adapted to be raised through the medium of a chain 18 which is attached to the bar b^2 and passes over guide pulleys 19 and 20 journaled on the fixed frame, under a pulley 21, journaled on a weighted lever 22, and up to a fixed hook 23 on the main frame. A second chain 24 is fastened to the under side of the lever 22 and passes under a pulley 25, journaled on a foot lever 26, up to a fixed hook 27 on the main frame. The weight of the lever 22 is sufficient to partly counterbalance but not to raise the movable frame B, but by pressing with the foot upon the lever 26 the said frame is raised easily, while upon releasing the lever the frame will again descend to its lowest position. A clamp 28 is fixed to the side piece 10 to clamp the chain 18 and retain the frame or carrier B in any desired position.

A series of compressors 29 are pivoted upon

a rod 30 which is fixed to the side bars *b*, *b*, of the frame B, slightly above and in the rear of the rod 12. Each compressor is formed as a plate, bent as shown in Fig. 2, and slotted centrally for the greater portion of its length except for a cross-piece 31 directly beneath the rod 12. Each tube D is passed through the slot of its respective compressor, as shown in Fig. 3, and is normally pinched between the cross-piece 31 and the fixed rod 12 by a stout spring 32 which is attached to the compressor and to the cross-bar *b'*, so as to prevent the flow of liquid through the tube. A bar 33 rests upon the ends of all the compressors and is supported by toggle levers 34, 34, from the cross-bar *b'* of the movable frame B. The toggle levers, at or near their joints, are connected to a second bar 35 which near its middle is provided with a pin 36 to enter a slot in the end of a hand-lever 37 pivoted upon the cross-bar *b'*. When the movable frame is at the lowest point of its movement and the tubes D are inserted in the bottles, as hereinafter described, the lever 37 is moved by the operator to throw the bar 35 toward the left and, through the toggle levers, to depress the bar 33 and so open the compressors 29, allowing the liquid to flow through the pipes D. As the frame moves up again the end of the bar 35 strikes a cam 38, which is fixed upon side-piece 10, and is thrown back to the right by the same to raise the bar 33 from the ends of the compressors and permit each compressor to be drawn upward by its spring 32 and again pinch the tube D between itself and the rod 12 to stop the flow of the liquid. It will be observed that each compressor is free to be moved independently of the rest and furthermore that if non-flexible tubes D were employed the same arrangement of levers and bars might be used to operate valves in place of the compressors.

Through the two apertures 16 of each head-block 15 pass freely two tubular rods or sleeves 39, 39, which are prevented from falling through the apertures by a head or flange at the top, and support at their lower ends a slotted plate 40, which overlies a stopper-ring 40^a which fits snugly about the tube D at some distance from its lower end. Springs 41, 41, surround the sleeves between the plate 40 and the head-block and serve to hold down the stopper-ring 40^a with a yielding pressure. Through the sleeves 39, 39, pass freely two rods 42, 42, which are also held from falling through by pins at their upper ends and which carry at their lower ends a conical guide-cap 43, made of rubber or of metal or other suitable material lined with a soft material like rubber.

In order that the functions and mode of operation of other parts of the improved machine may be more readily understood I will now set forth briefly the mode of operation of the parts already described. The tubes D, D, having been filled with liquid and a suit-

able pressure being maintained on the surface of the liquid in the cask D', a number of bottles are placed in line beneath the conical caps 43, the latter being normally held slightly above the tops of the bottles. The chain 18 being now released from the clamp 28 the frame or carrier B will begin to descend. The caps 43 will first strike the tops of the bottles and will rest thereon by their own weight and the weight of the rods 42, the tubes D, D, which pass freely through the tops of the caps and are never raised clear of them, being guided by the caps into the necks of the bottles. As the frame continues to descend the stoppering 40^a will be carried down by the plates 40 until they rest firmly upon the tops of the bottles, or, what is virtually the same thing, upon the tops of the guide-caps which themselves rest upon the tops of the bottles, the object being to make a tight connection between the bottles and the tubes D, D, which have been passed into the bottles. Any slight differences in the height of the bottles will be compensated for by the yielding of the springs 41. The lever 37 is now thrown over by the operator thereby releasing the tubes D from the compressors and permitting the liquid to flow freely through the tubes. When the bottles are full the operator places his foot on the treadle 26 and raises the frame again to its highest position, the compressors being again permitted to pinch the tubes D, D, through the action of the incline 38 on the end of the bar 35 as the latter is raised.

It may be stated here that in order to prevent the possible escape of liquid from the lower portions of the tubes D I have provided means to close the lower ends of the tubes just as they are withdrawn from the bottles. These means consist of a shaft 44 journaled in bearings 45 fixed to the side-pieces 10 and having a finger or tongue 46 opposite each tube; arms 47 projecting from the shaft have pivoted to them rods 48 which pass freely through arms 49 extending from the cross-bar *b'* of the movable frame B, each rod having a collar or pin above its arm 49. The weight of the rods 48 normally rocks the shaft to turn the tongues 46 away from the tubes, but when the frame or carrier B reaches its highest point the arms 49 lift the rods 48 and rock the shaft 44 to turn the tongues against the tubes and compress them against or over the tops of the caps 43.

As before stated one object of my improvements is to provide means whereby the pressure on the liquid in the cask may be maintained or increased and the air or foam may be withdrawn from the bottle as the liquid flows into the same. Accordingly I include within each stopper-ring 40^a a second tube 50 which projects below the said ring or sleeve just far enough to enter the mouth of the bottle. This tube is not passed through the compressor but is connected to a suction or force pump 51, the delivery tube 52 of which is connected to the bung 17 of the cask D'. The

pump may be operated in different ways but I prefer to fix the cylinder thereof to the movable frame B to be moved up and down therewith. The piston rod 53 of the pump is fixed to a cross-head 54 to which are rigidly secured depending arms 55. To the lower end of each of these arms is attached a strong spiral spring 56, the upper end of which is attached to a yoke 57 carried by the cross-bar 11 of the main frame. The tendency of the springs is to keep the piston rod up as the cylinder descends, but as this would cause the suction to begin before the stopper-ring 40^a is seated upon the bottle mouth or the cap 43, I delay the action of the springs by a spring-pressed double latch 58 which is pivoted to the cross-bar b' of the movable frame B and engages the cross-head 54. The lower end of the latch enters a hole in a finger 33^a carried by the bar 33, so that when the lever 37 is thrown over by the operator to permit the liquid to flow through the pipes the latch is moved from the cross-head and the springs 56 are permitted to raise the piston quickly, thereby exhausting the air from the bottles. When the movable frame B and the cylinder again rise the inclined end of the latch 58, which rises with them, strikes the cross-head and is thrown back so that when it is again thrown forward by its spring it shall again engage the cross-head preparatory to the next operation; the cross-head is steadied and prevented from turning or yielding by depending fingers 59. During the upward movement of the cylinder the air therein is forced out. If it is desired only to exhaust the air from the bottles the air might be discharged directly from the pump, but if the delivery tube 52 is connected to the cask, as above stated, the discharge of the air into the cask will maintain or increase the pressure on the surface of the liquid therein and will thereby facilitate the operation of bottling. At any time the pump can be worked independently to increase the pressure in the cask or to remove foam from the bottles, by using the cross-head as a handle.

As shown in Figs. 2, 3 and 5, each tube 50 is connected to a nipple 60 which communicates with a chamber 61 at the lower end of the pump cylinder. Above this chamber is seated a valve 62 which opens upwardly into the cylinder itself, screws 63 being inserted to limit the movement of the valve. The discharge or delivery tube 52 is connected to a nipple 64, which communicates with the cylinder above the valve 62 and is itself provided with an outwardly opening valve 65. The pump is thus of ordinary construction and operates in a well known manner.

The bottles to be filled may be placed in the machine in boxes which are set upon an endless apron 66 formed of slats and chains, supported by wheels 67 mounted on shafts 68. One of the shafts 68 has fixed thereon a ratchet-wheel 69 which is advanced by a pawl 70 on a lever 71. By placing suitable stops

in the path of the lever 71 its range may be so limited that a single movement will advance the apron sufficiently to bring the next row of bottles under the caps 43.

While my improved machine is designed especially for bottling beer and other similar liquids and operates with great efficiency with such liquids, it may also be used with equally good results with any liquid whatever.

I claim as my invention—

1. In a bottling apparatus, the combination with a closed reservoir for the liquid to be bottled, a filling tube, means to present the filling tube to the bottle to be filled, a force pump operated by said means, and a connection from said pump to said reservoir, and independent of said filling tube whereby the pressure on the liquid in the reservoir may be maintained or increased as the apparatus is operated.
2. In a bottling apparatus, the combination with a closed reservoir for the liquid to be bottled, a filling tube, a reciprocating carrier to present the filling tube to the bottle to be filled, a force pump operated by said carrier, and a connection from said pump to said reservoir and independent of said filling tube.
3. In a bottling apparatus, the combination with a filling tube and means to present the same to the bottle to be filled, of a second tube presented with said filling tube to the bottle, and a pump to withdraw the air from the bottle through said second tube.
4. In a bottling apparatus, the combination with a filling tube and a second tube, a stopper-ring embracing said tubes and adapted to make a tight connection between the same and the bottle, and a pump connected to said second tube to withdraw the air from the bottle.
5. In a bottling apparatus, the combination of a closed reservoir for the liquid to be bottled, a filling tube and a second tube, a stopper-ring embracing said tubes and adapted to make a tight connection between the same and the bottle, a pump connected to said second tube, and a tube connecting said pump and said reservoir, whereby the air may be withdrawn from the bottle and forced into said reservoir.
6. In a bottling apparatus, the combination of a filling tube and a second tube, a stopper-ring embracing both of said tubes and adapted to make a tight connection between the same and the bottle, a reciprocating carrier to present said tubes to the bottle, and a pump operated by said carrier and connected to said second tube to withdraw the air from the bottle.
7. In a bottling apparatus, the combination of a pump having its cylinder fixed to the frame-work, a spring acting upon the piston rod of said pump to move it in one direction, a reciprocating frame to present the filling tube to the bottle a latch carried by said reciprocating frame and adapted to engage the

piston rod to move it in the opposite direction, and means to release the latch from the piston rod.

8. In a bottling apparatus, the combination
 5 of a filling tube, a reciprocating carrier to present the tube to the bottle to be filled, a pump, a spring acting upon the piston of the pump to move it in one direction, a latch supported
 10 by said carrier and adapted to engage the piston to move it in the opposite direction, a compressor or valve to prevent the flow of liquid through said pipe, and means to move said
 15 compressor or valve to permit the flow and at the same time to release the latch from the piston.

9. In a bottling apparatus, the combination of a series of filling tubes, a corresponding series of independent spring-pressed levers, each adapted to cut off the flow in its respective
 20 tube, a bar resting against said levers, and means to move said bar bodily to press all of said levers from the tubes.

10. In a bottling apparatus, the combina-

tion of a filling tube, a reciprocating carrier to present said tube to the bottle to be filled, 25 a device mounted on said carrier for cutting off the flow of liquid in said tube, a bar also mounted on said carrier to operate said device, and a cam mounted on the fixed frame whereby said bar is actuated as it is reciprocated with the carrier. 30

11. In a bottling apparatus, the combination of a flexible filling tube, a reciprocating carrier, a rock shaft supported on the framework, a tongue projecting from said shaft and adapted to compress said tube, and means operated by said carrier to rock said shaft and compress the tube when said tube is withdrawn from the mouth of the bottle. 35

In testimony whereof I have signed my name to this specification in the presence of two subscribing witnesses. 40

MELVIN E. DONALLY.

Witnesses:

A. N. JESBERA,
 A. WIDDER.