



US 20200080094A1

(19) **United States**

(12) **Patent Application Publication**

Zhang et al.

(10) **Pub. No.: US 2020/0080094 A1**

(43) **Pub. Date: Mar. 12, 2020**

(54) **CRISPR-CAS COMPONENT SYSTEMS, METHODS AND COMPOSITIONS FOR SEQUENCE MANIPULATION**

plication No. 61/791,409, filed on Mar. 15, 2013, provisional application No. 61/835,931, filed on Jun. 17, 2013.

(71) Applicants: **The Broad Institute, Inc.**, Cambridge, MA (US); **Massachusetts Institute of Technology**, Cambridge, MA (US); **President and Fellows of Harvard College**, Cambridge, MA (US)

(72) Inventors: **Feng Zhang**, Cambridge, MA (US); **Le Cong**, Cambridge, MA (US); **David Benjamin Turitz Cox**, Cambridge, MA (US); **Patrick Hsu**, Cambridge, MA (US); **Shuailiang Lin**, Cambridge, MA (US); **Fei Ran**, Boston, MA (US); **Randall Jeffrey Platt**, Cambridge, MA (US); **Neville Espi Sanjana**, Cambridge, MA (US)

(21) Appl. No.: **16/535,043**

(22) Filed: **Aug. 7, 2019**

Related U.S. Application Data

(63) Continuation of application No. 15/230,161, filed on Aug. 5, 2016, which is a continuation of application No. 14/105,035, filed on Dec. 12, 2013, now abandoned.

(60) Provisional application No. 61/736,527, filed on Dec. 12, 2012, provisional application No. 61/748,427, filed on Jan. 2, 2013, provisional application No. 61/768,959, filed on Feb. 25, 2013, provisional ap-

Publication Classification

(51) **Int. Cl.**
C12N 15/74 (2006.01)
C12N 15/90 (2006.01)
C12N 15/85 (2006.01)
C12N 15/70 (2006.01)
C12N 15/63 (2006.01)
C12N 9/22 (2006.01)
C12N 15/113 (2006.01)
(52) **U.S. Cl.**
CPC *C12N 15/746* (2013.01); *C12N 15/907* (2013.01); *C12N 15/8509* (2013.01); *C12N 15/74* (2013.01); *C12N 15/70* (2013.01); *C12N 15/1082* (2013.01); *C12N 15/63* (2013.01); *C12N 9/22* (2013.01); *C12N 15/113* (2013.01); *C12N 2800/101* (2013.01); *C12N 15/85* (2013.01)

(57) **ABSTRACT**

The invention provides for systems, methods, and compositions for manipulation of sequences and/or activities of target sequences. Provided are vectors and vector systems, some of which encode one or more components of a CRISPR complex, as well as methods for the design and use of such vectors. Also provided are methods of directing CRISPR complex formation in eukaryotic cells and methods for selecting specific cells by introducing precise mutations utilizing the CRISPR/Cas system.

Specification includes a Sequence Listing.

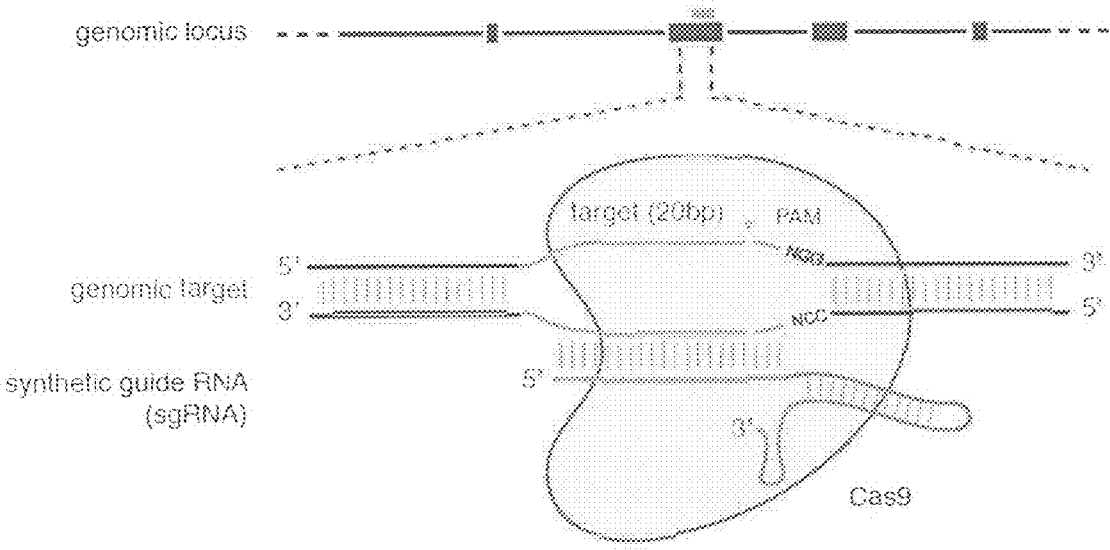

FIG. 1

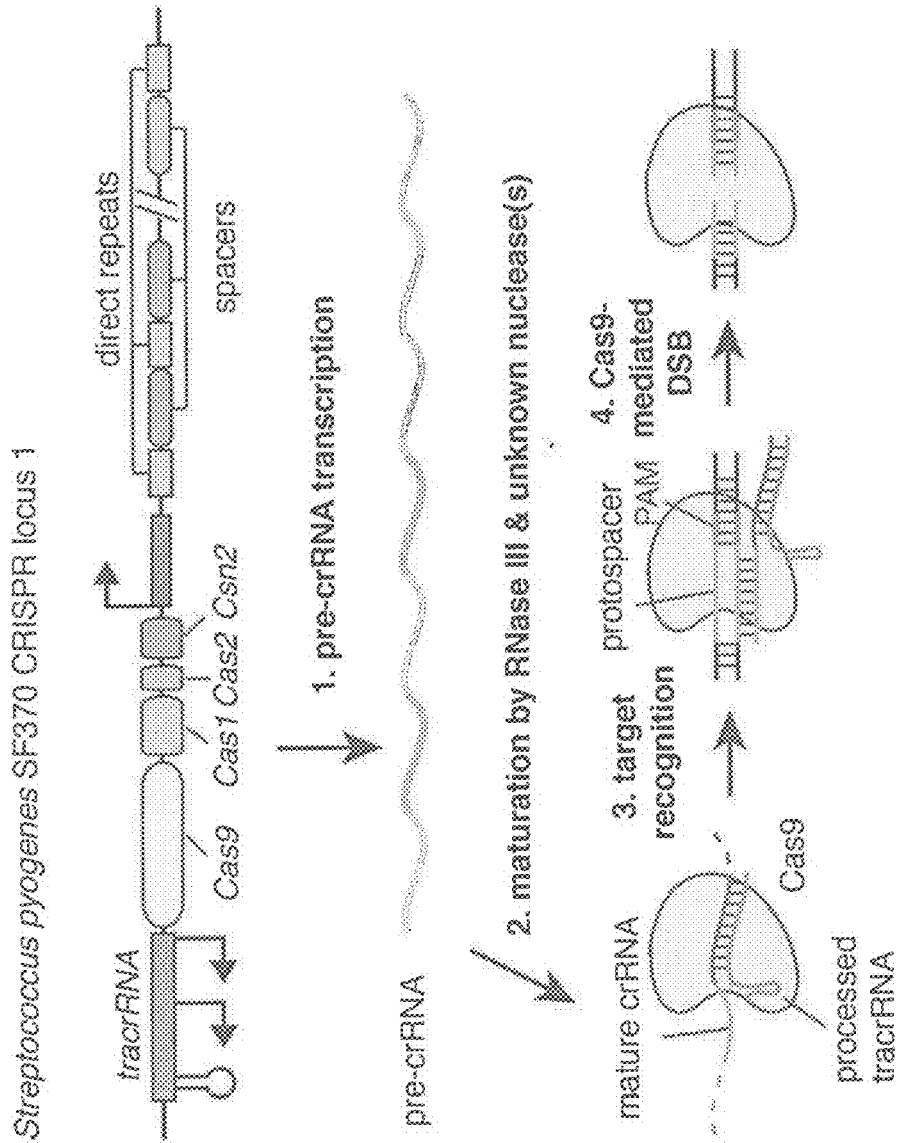

FIG. 2A

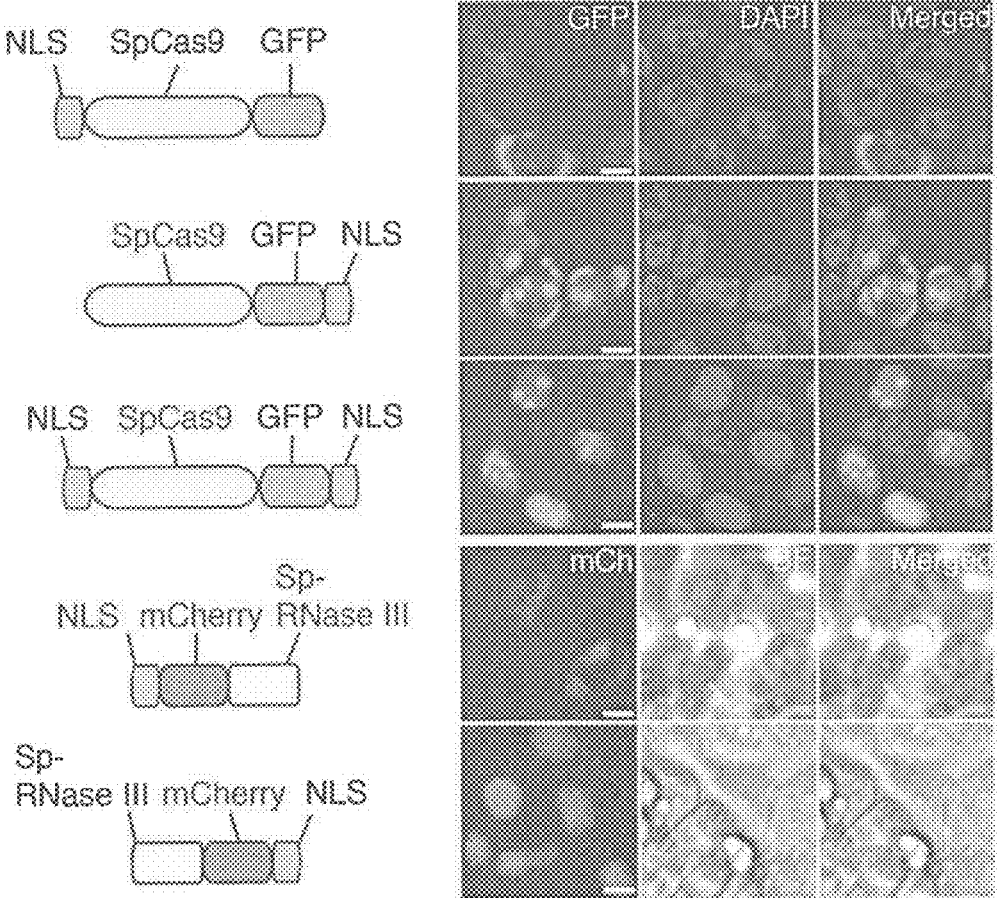

FIG. 2B

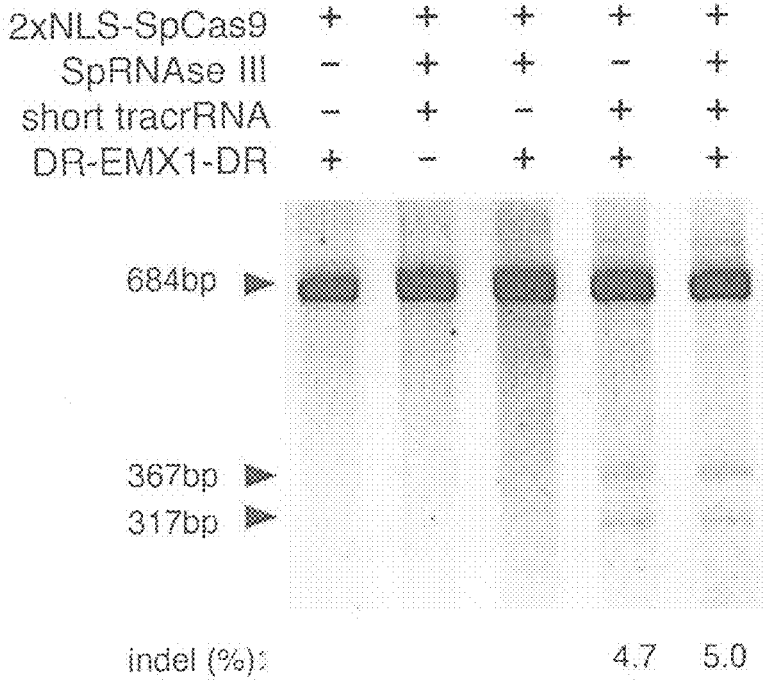

FIG. 2D

FIG. 2E

Target locus 5' - . . . AGCTGGAGGAGGAGGGCCCTGAGTCCGAGCAGAAAGAAGGGCTCCCAC . . . -3'
 PAM
 |||||
 3' - . . . TCGACCTCTCCCTCCGGACTCAGGGCTGGTCTTCTTCCCGAGGGTG . . . -5'
 |||||
 crRNA 5' - GAGJCCGAGCAGAAAGAAGUUUAGAGC . . . -3'

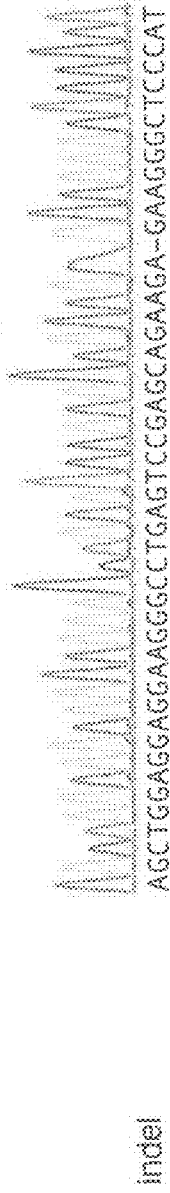

FIG. 2F

human EMX1 protospacer target (mutation in 5 of 43 sequenced clones = 11.6%)
 WT 5' - . . . CTGGAGGAGGAAAGGGCCCTGAGTCCGAGCAGAAAG AAGAAGGGCTCCCATCACAT . . . -3'
 Δ1 CTGGAGGAGGAAAGGGCCCTGAGTCCGAGCAGAAAG--AGAAGGGCTCCCATCACAT
 +1 CTGGAGGAGGAAAGGGCCCTGAGTCCGAGCAGAAAGAAGAAGGGCTCCCATCACAT
 Δ3 CTGGAGGAGGAAAGGGCCCTGAGTCCGAGCAGAAAG-- --AAGGGCTCCCATCACAT
 mt1, Δ6 CTGGAGGAGGAAAGGGCCCTGAGCCCGAGCAGAAAG-- -- --GGCTCCCATCACAT

FIG. 3A



FIG. 3B

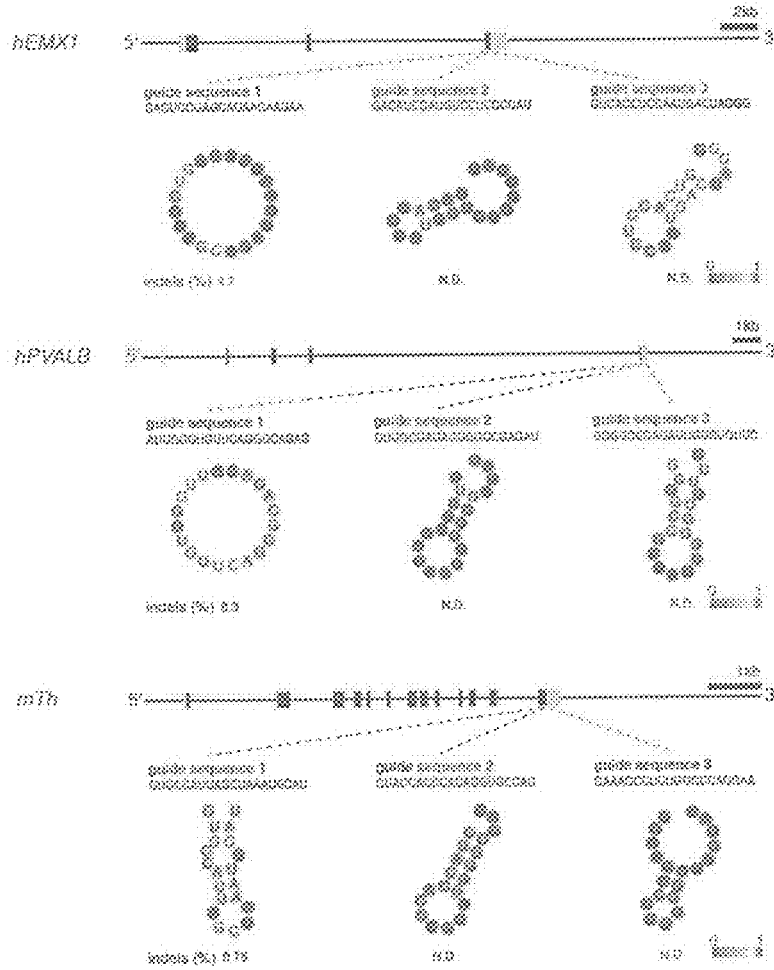

FIG. 3C

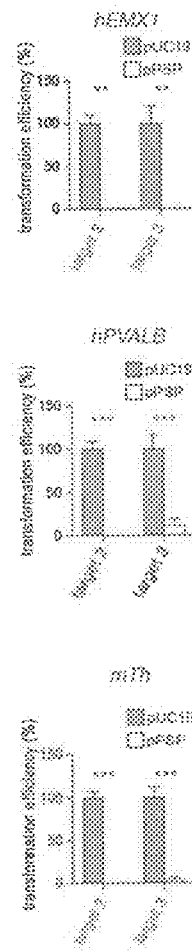

FIG. 4A

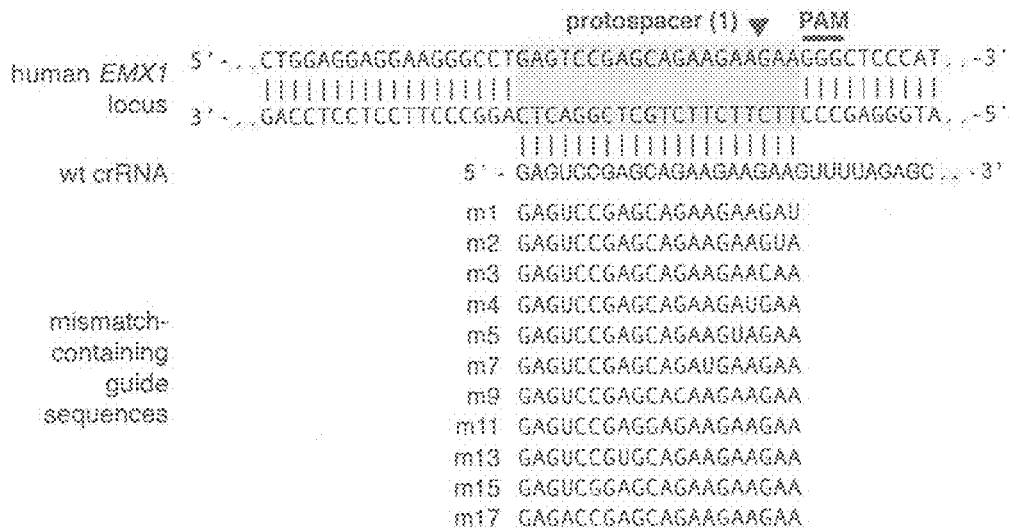

FIG. 4B

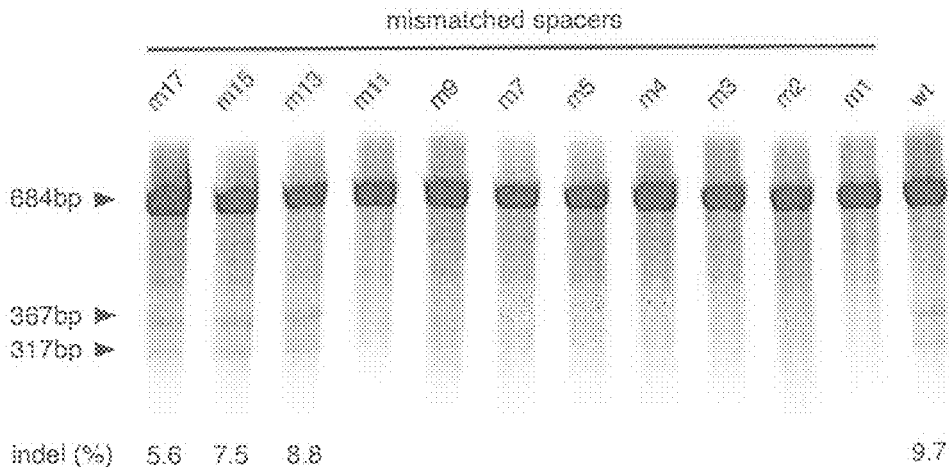
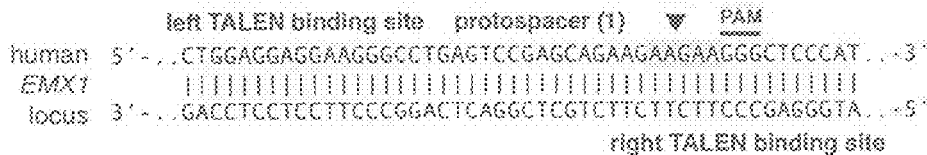

FIG. 4C



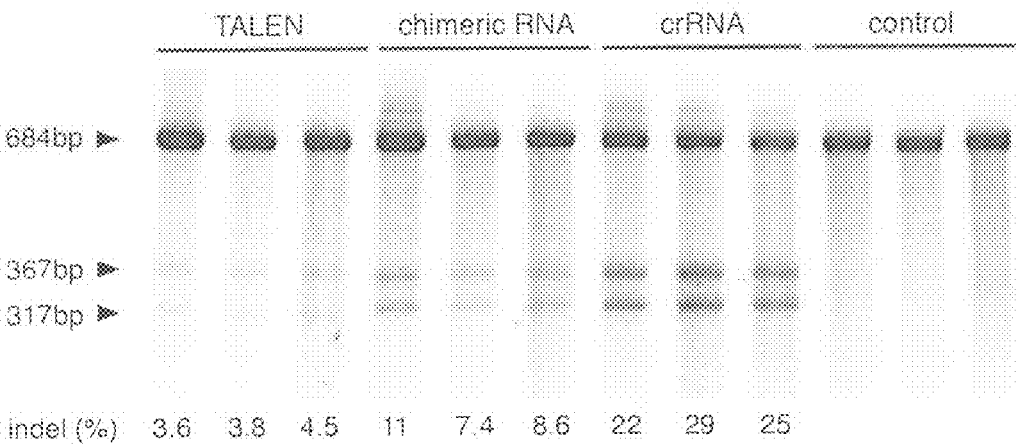

FIG. 4D

FIG. 5A

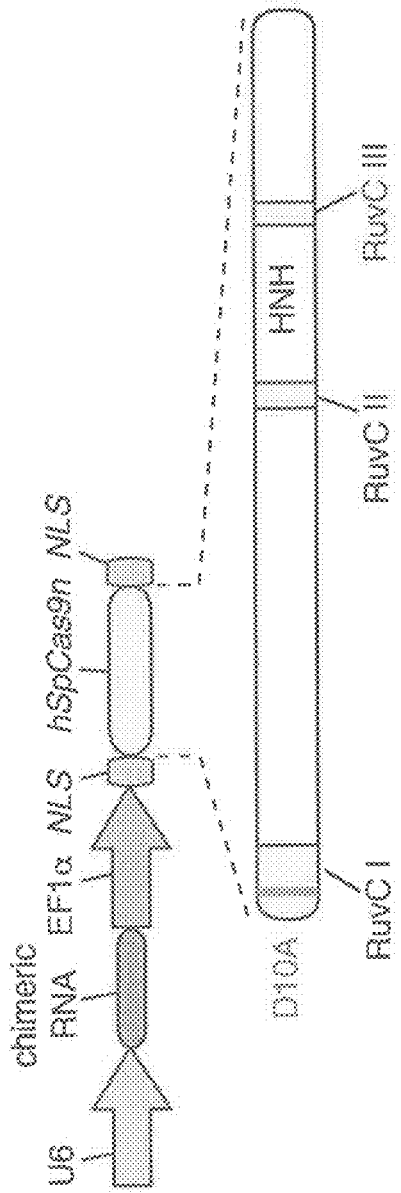

FIG. 5B

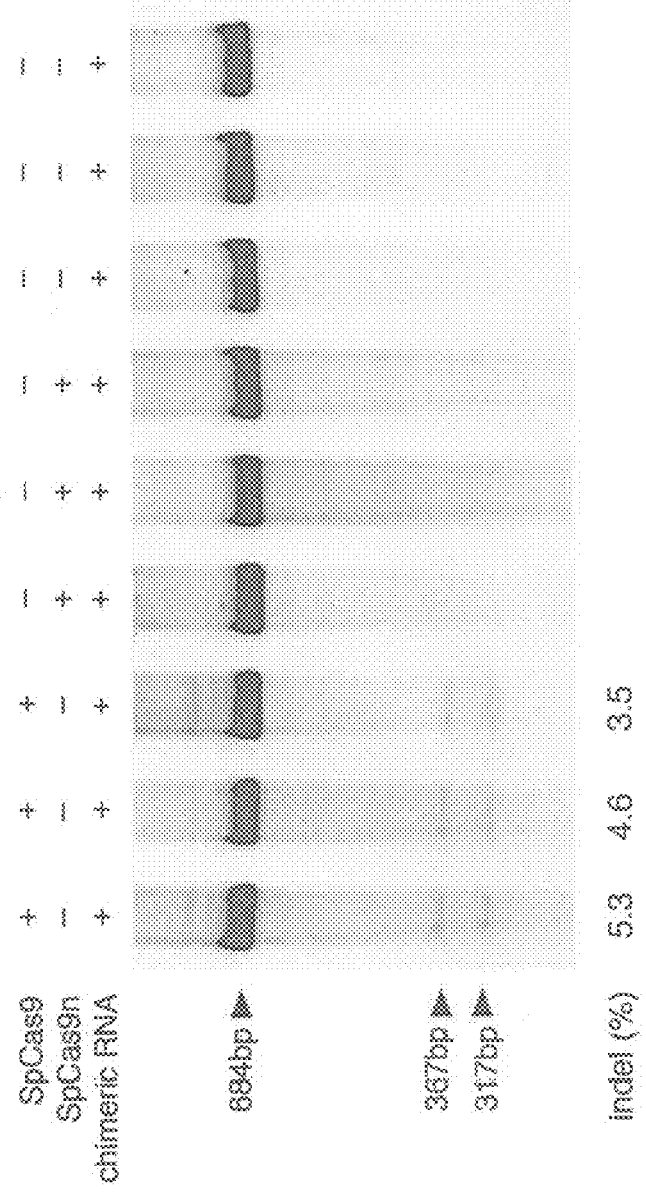

FIG. 5C

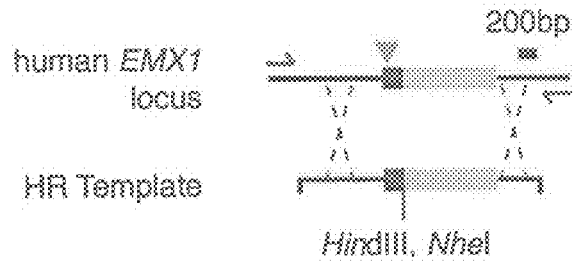

FIG. 5D

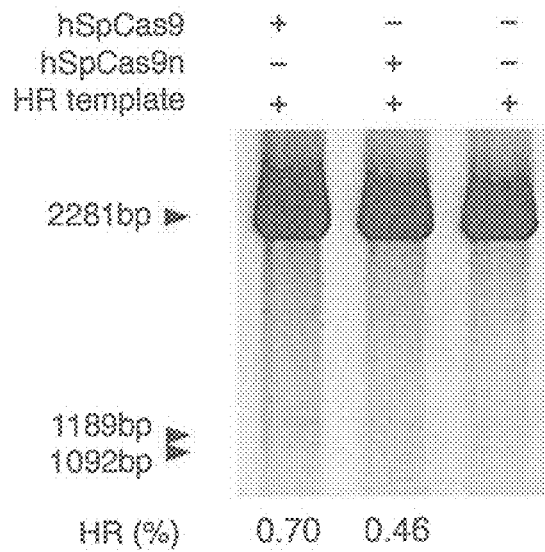
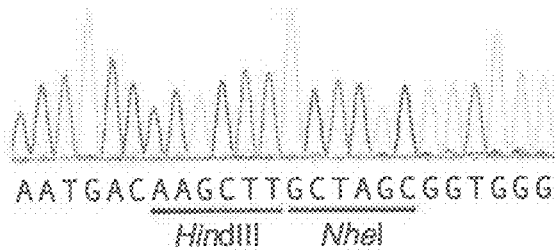

FIG. 5E



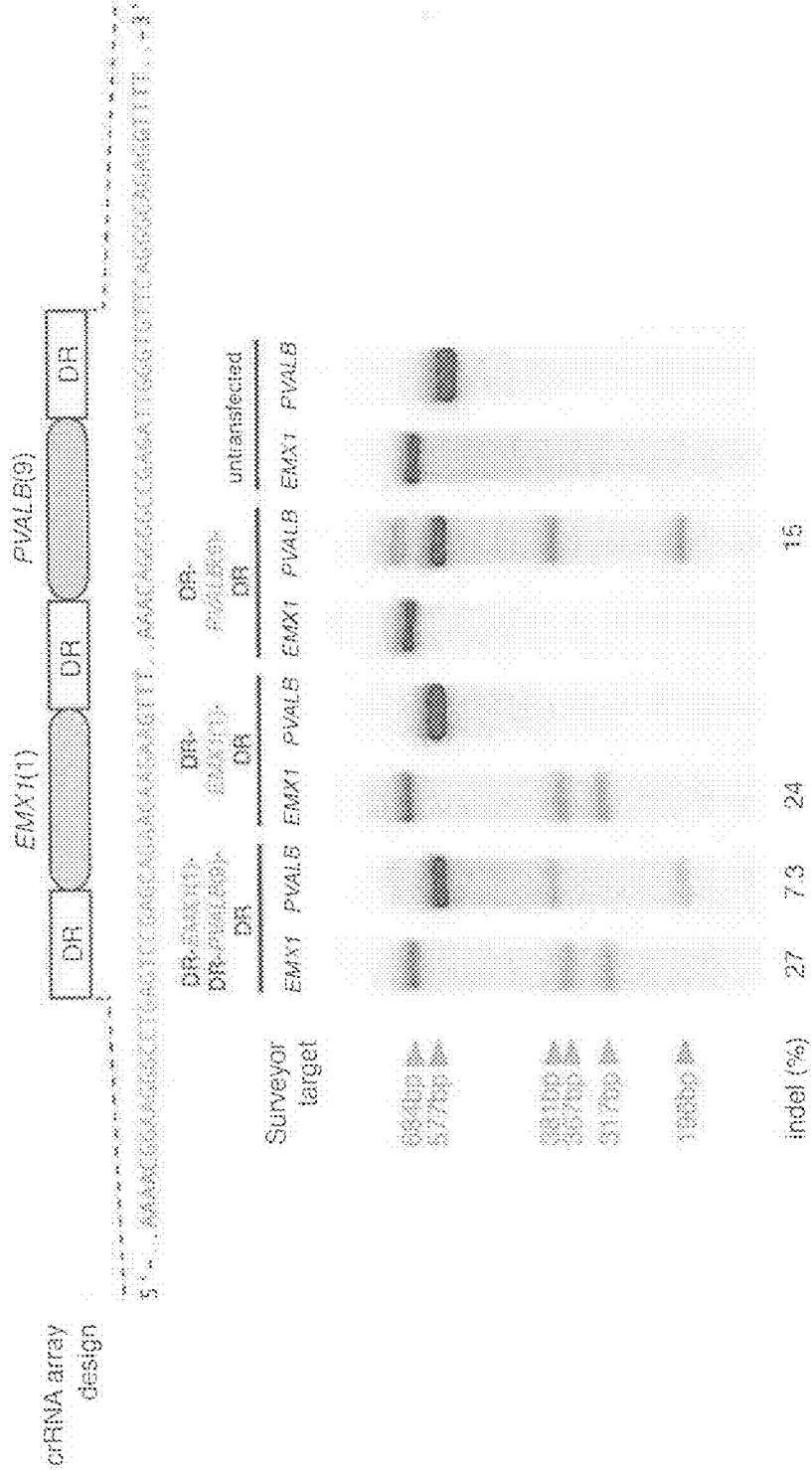

FIG. 5F

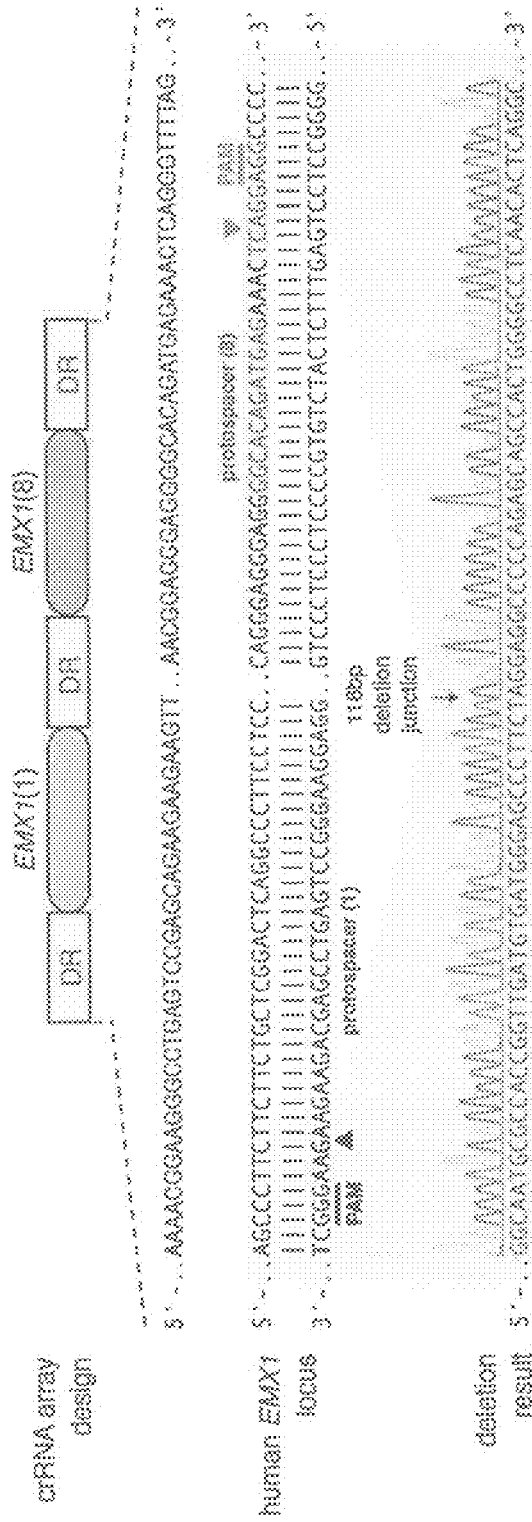

FIG. 5G

Case	target species	gene	protospacer ID	protospacer sequence (5' to 3')	PAM	strand	cell line tested	% indel (pre-crRNA + tracrRNA)	% indel (chimeric RNA)
<i>S. pyogenes</i> SP370 type II CRISPR	Homo sapiens	EMX1	1	GGAGGGCTGATCCGAGCAGAGAGAA	GGG	+	293FT	20 ± 1.8	6.7 ± 0.62
			2	CATTGAGGTGATGATGATGCTCCCAT	TGG	-	293FT	2.1 ± 0.31	N.D.
			3	GGACATGATGTACCTCCANTACTAGG	TGG	+	293FT	14 ± 1.1	N.D.
			4	CATCGATGCTCCCTTGGCTGCTTGG	TGG	-	293FT	11 ± 1.7	N.D.
			5	TTCGTGGCANTGCCACCGCTTGAATGA	TGG	-	293FT	4.3 ± 0.46	2.1 ± 0.51
			6	TCTGGCANTGCCACCGCTTGAATGAT	GGG	-	293FT	4.0 ± 0.66	0.41 ± 0.25
			7	TCCAGCTTCTCCGCTTGTACTTTGCTTC	GGG	-	293FT	1.5 ± 0.12	N.D.
			8	GGAGGAGGGGACAGATGAGAACTCGG	AGG	-	293FT	7.8 ± 0.63	2.3 ± 1.2
Homo sapiens	PVALB	9	AGGCCCCAGATTGGGTTCAGGGCAGAG	AGG	+	293FT	21 ± 2.6	6.5 ± 0.32	
		10	ATCTAGGAGGTGCTCCAGAGGGCTCAGAT	TGG	+	293FT	N.D.	N.D.	
		11	GGTGGCAGAGGGCCGAGATTGGGTCTC	AGG	+	293FT	N.D.	N.D.	
<i>Mus musculus</i>	Th	12	CAGCTACTGACTGCTTACTTAATGCTAT	AGG	-	Neuro2A	27 ± 4.9	4.1 ± 2.2	
		13	ATGCTATAGGTATCCACCACAGAGTCCAG	TGG	-	Neuro2A	4.6 ± 1.2	N.D.	
		14	ACACACATGGGAGGCTCTGGCCAGGAA	AGG	+	Neuro2A	11.3 ± 1.3	N.D.	
		15	GGAGCAGTATGATACAGAAACACAGAGAA	GTAGCAT	-	293FT	14 ± 0.88	N.T.	
LMD-9 CRISPR	Homo sapiens	EMX1	16	AGATGTAGAGGAGTCCAGAAACTCAGCA	CTAGGAA	-	293FT	7.8 ± 0.77	N.T.

FIG. 6

FIG. 7A

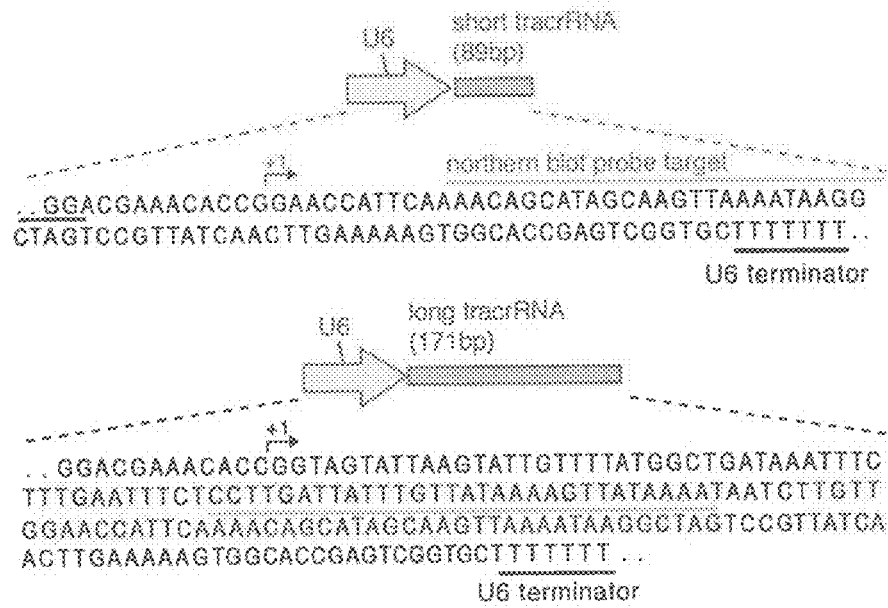
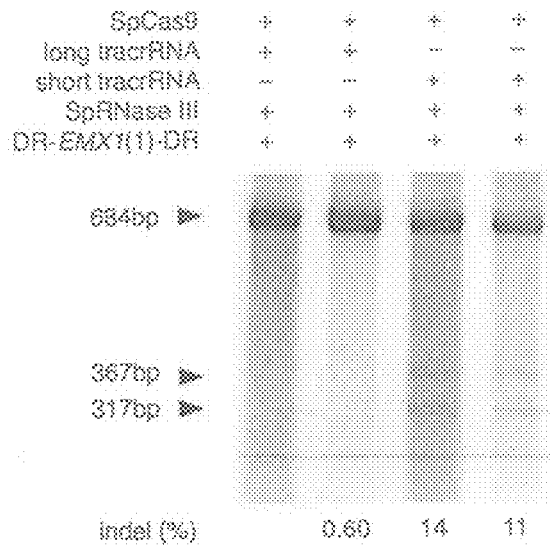

FIG. 7B



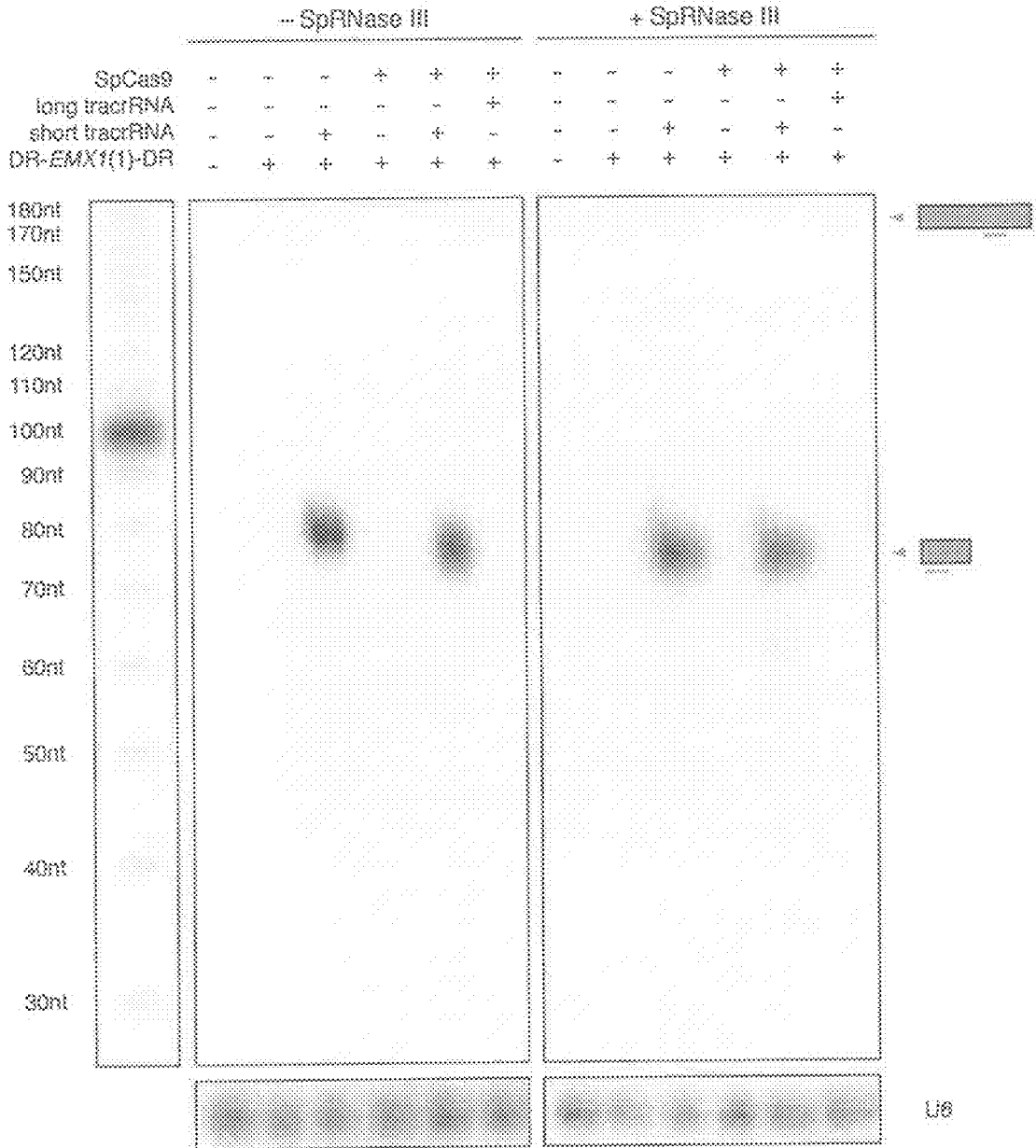

FIG. 7C

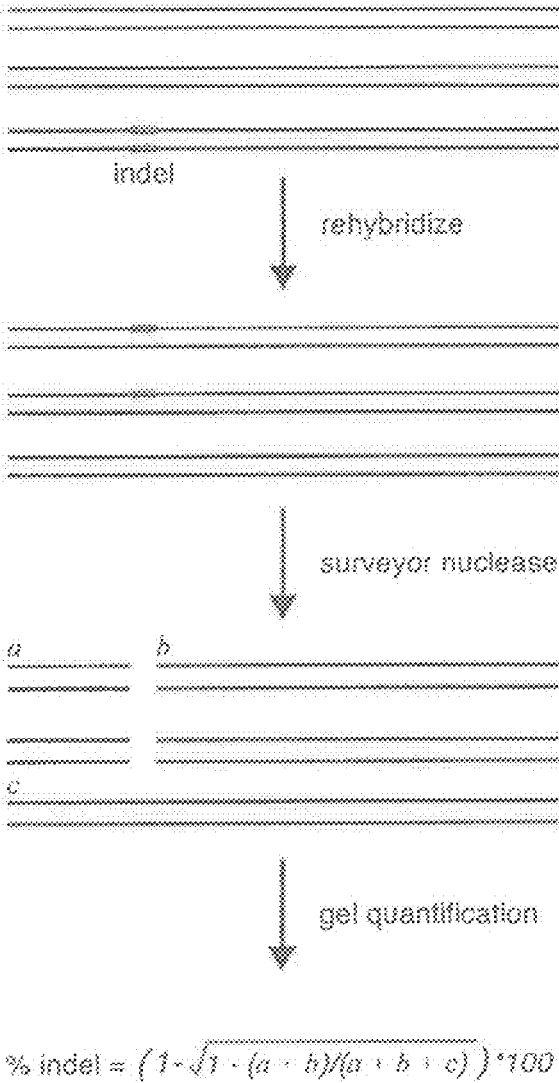
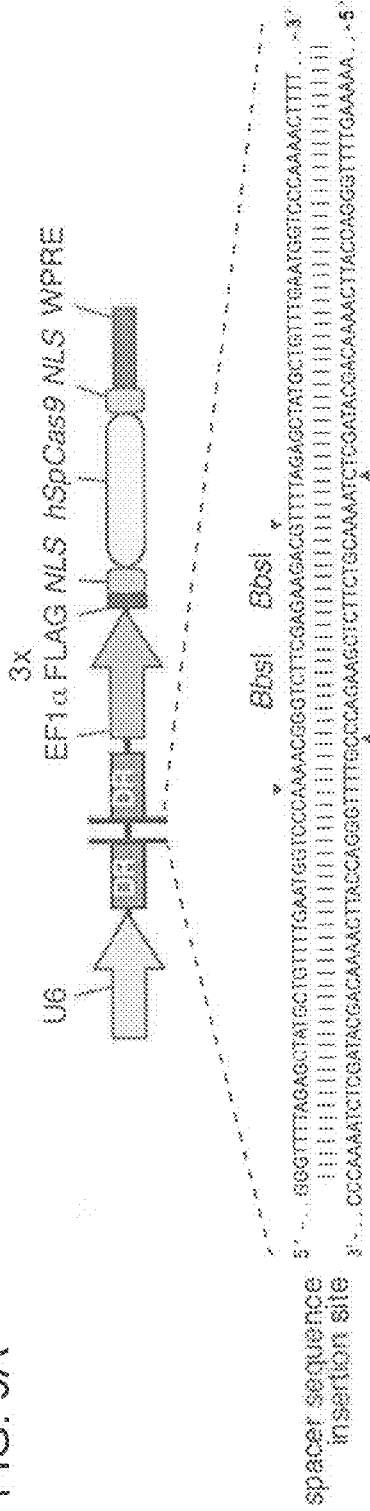

FIG. 8

FIG. 9A



5' - AAACNNNNNNNNNNNNNNNNNNNNNNNGT - 3'
 spacer sequence
 insert
 3' - NNNNNNNNNNNNNNNNNNNNNNNNNNNNNNNCAAAAT - 5'

FIG. 9B

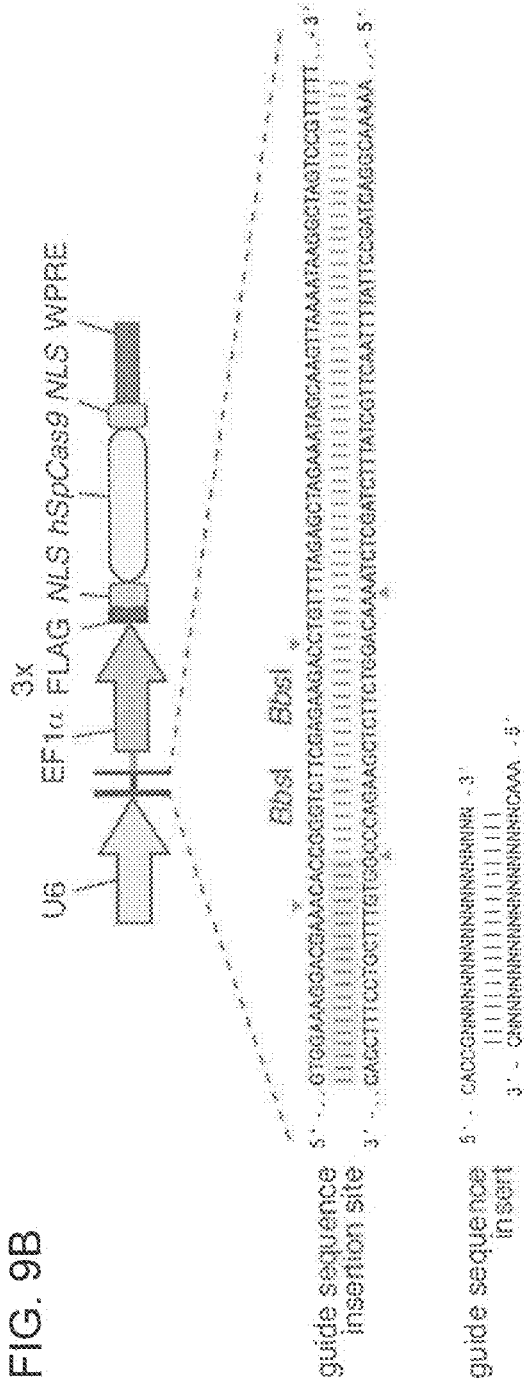

FIG. 10A

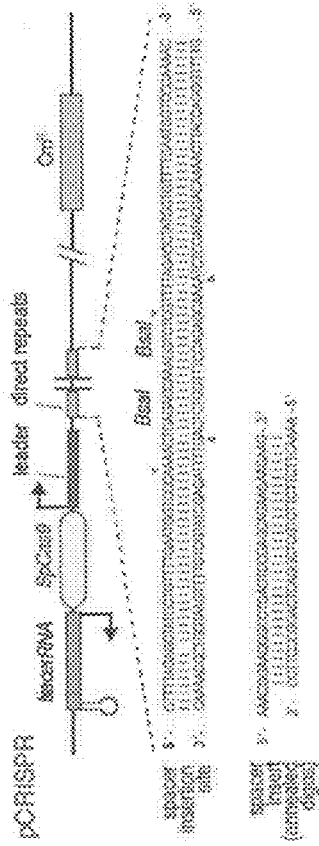

FIG. 10B

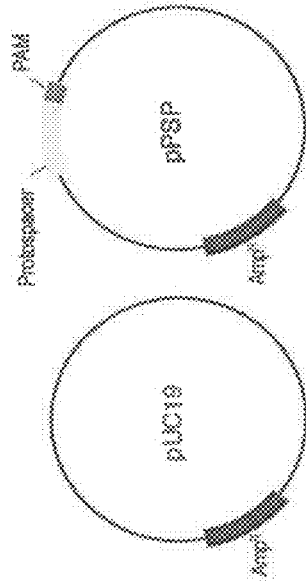

FIG. 10C

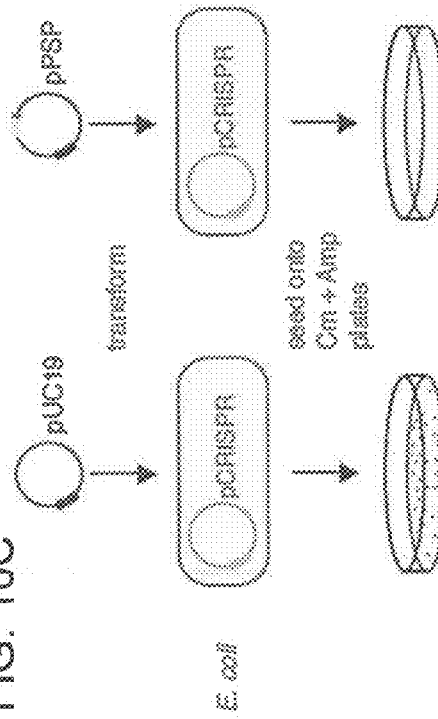

FIG. 10D

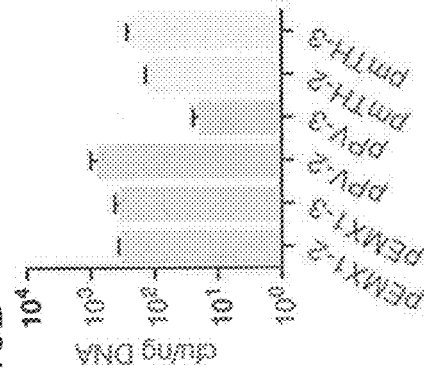

FIG. 11C

Chr	NGG		NNAGAAW	
	median	mean	median	mean
1	7	12.8	67	115.8
2	8	12.7	64	100.8
3	8	13.0	63	98.5
4	9	14.0	61	94.5
5	8	13.1	63	97.9
6	8	13.1	63	98.5
7	8	12.4	64	102.9
8	8	12.8	64	100.9
9	7	13.9	65	120.5
10	7	12.1	66	107.0
11	7	12.0	65	105.8
12	8	12.4	65	103.5
13	8	13.6	62	94.8
14	8	12.0	65	101.5
15	7	11.5	68	107.7
16	7	11.7	74	136.8
17	6	10.3	76	127.9
18	8	13.4	63	101.8
19	6	9.4	82	145.4
20	7	11.1	72	121.8
21	7	13.4	64	111.4
22	6	9.2	85	140.3
X	6	13.2	63	99.0
Y	8	29.2	62	223.7

FIG. 11A

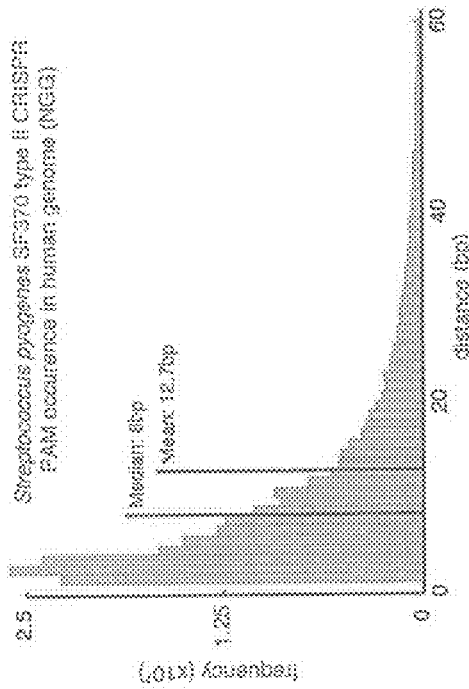

FIG. 11B

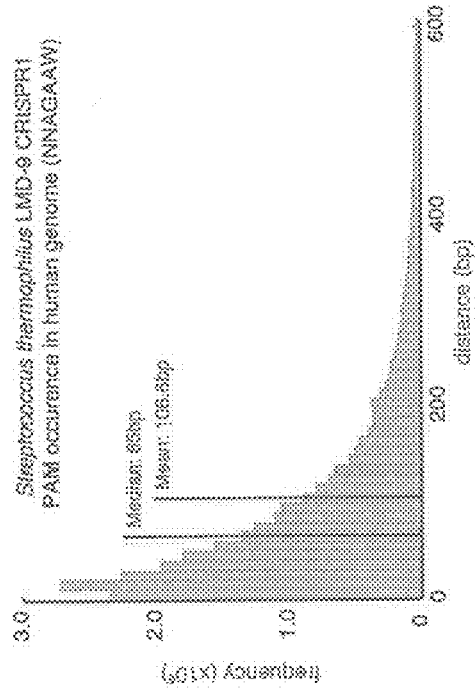

FIG. 14A

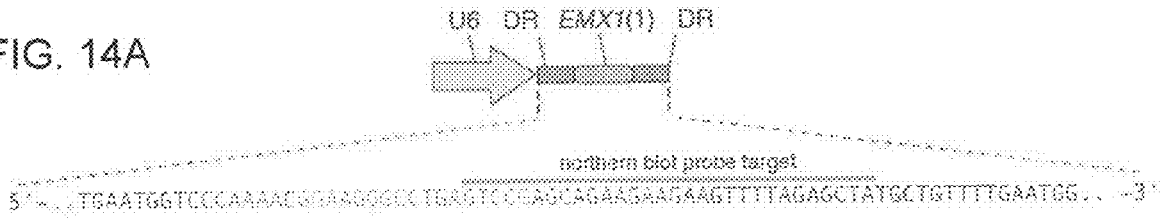

FIG. 14B

	- SpRNase III						+ SpRNase III					
SpCas9	-	-	-	+	+	+	-	-	-	+	+	+
long tracrRNA	-	-	-	-	-	+	-	-	-	-	-	+
short tracrRNA	-	-	+	-	+	-	-	-	+	-	+	-
DR-EMX1(1)-DR	-	+	+	+	+	+	-	+	+	+	+	+

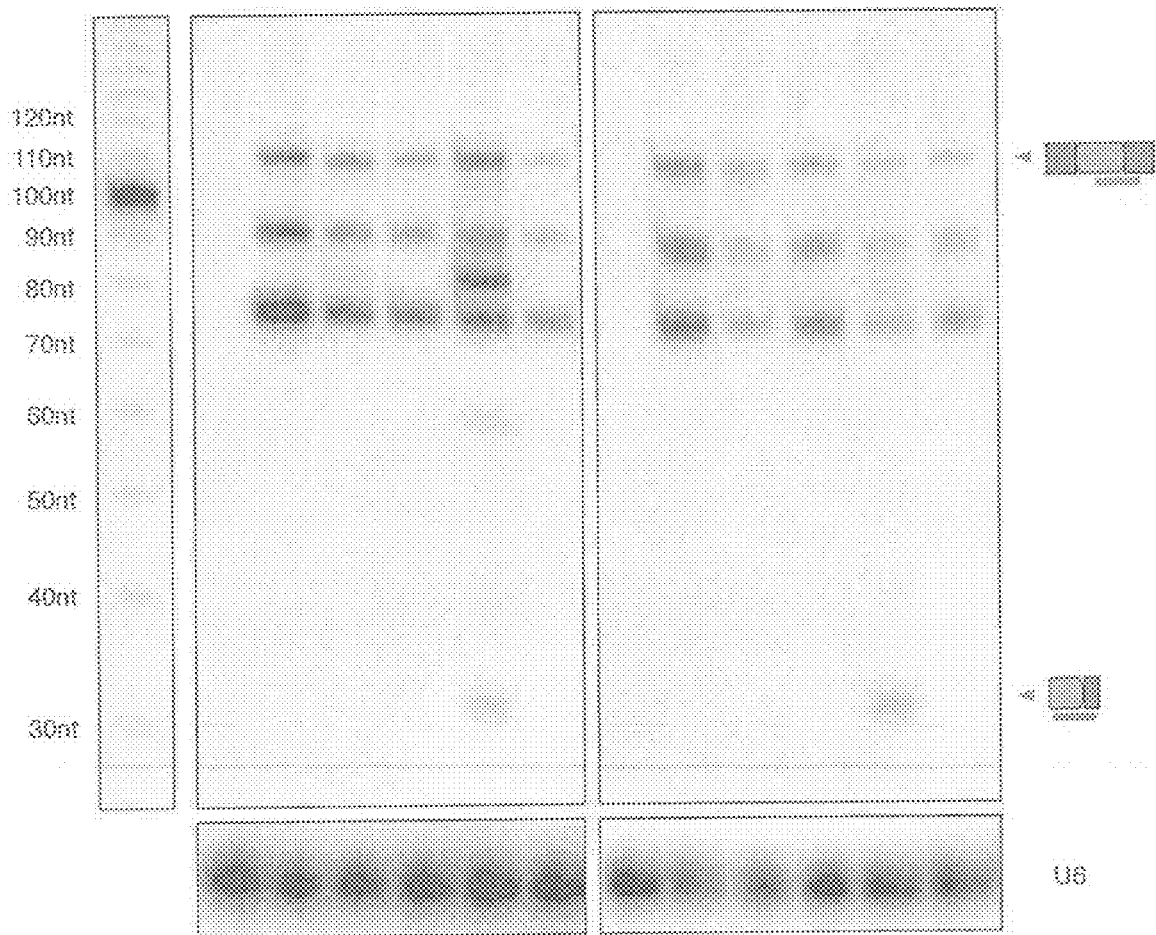

FIG. 15A

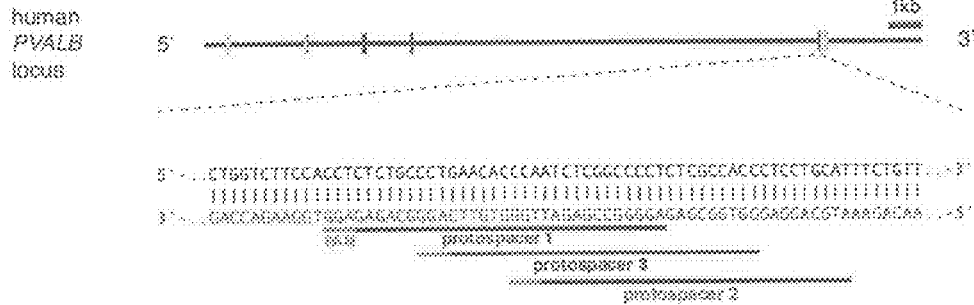

FIG. 15B

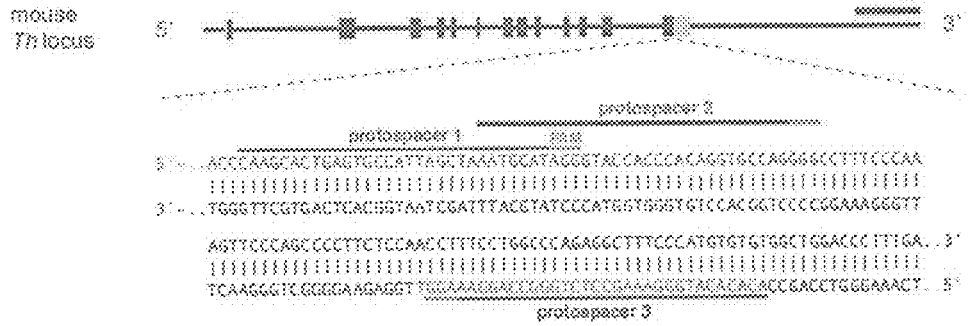



FIG. 16

Primer name	Assay	Genomic Target	Primer sequence
Sp-EMX1-F	SURVEYOR assay, sequencing	<i>EMX1</i>	AAAACCACCCCTTCTCTCTGGC
Sp-EMX1-R	SURVEYOR assay, sequencing	<i>EMX1</i>	GGAGATTGGAGACACGGAGAG
Sp-PVALB-F	SURVEYOR assay, sequencing	<i>PVALB</i>	CTGGAAAGCCAATGCCTGAC
Sp-PVALB-R	SURVEYOR assay, sequencing	<i>PVALB</i>	GGCAGCAAACCTCCTTGTCCT
Sp-Th-F	SURVEYOR assay, sequencing	<i>Th</i>	GTGCTTTGCAGAGGCTTACC
Sp-Th-R	SURVEYOR assay, sequencing	<i>Th</i>	CCTGGAGCGCATGCAGTAGT
St-EMX1-F	SURVEYOR assay, sequencing	<i>EMX1</i>	ACCTTCTGTGTTCCACCATTCC
St-EMX1-R	SURVEYOR assay, sequencing	<i>EMX1</i>	TTGGGGAGTGCACAGACTTC
Sp-EMX1- RFLP-F	RFLP, sequencing	<i>EMX1</i>	GGCTCCCTGGGTTCAAAGTA
Sp-EMX1- RFLP-R	RFLP, sequencing	<i>EMX1</i>	AGAGGGGTCTGGATGTCGTAA
Pb_EMX1_sp1	Northern Blot Probe	Not applicable	TAGCTCTAAAACCTTCTTCTTCTGCTCGGAC
Pb_tracrRNA	Northern Blot Probe	Not applicable	CTAGCCTTATTTTAACTTGCTATGCTGTTT

FIG. 17

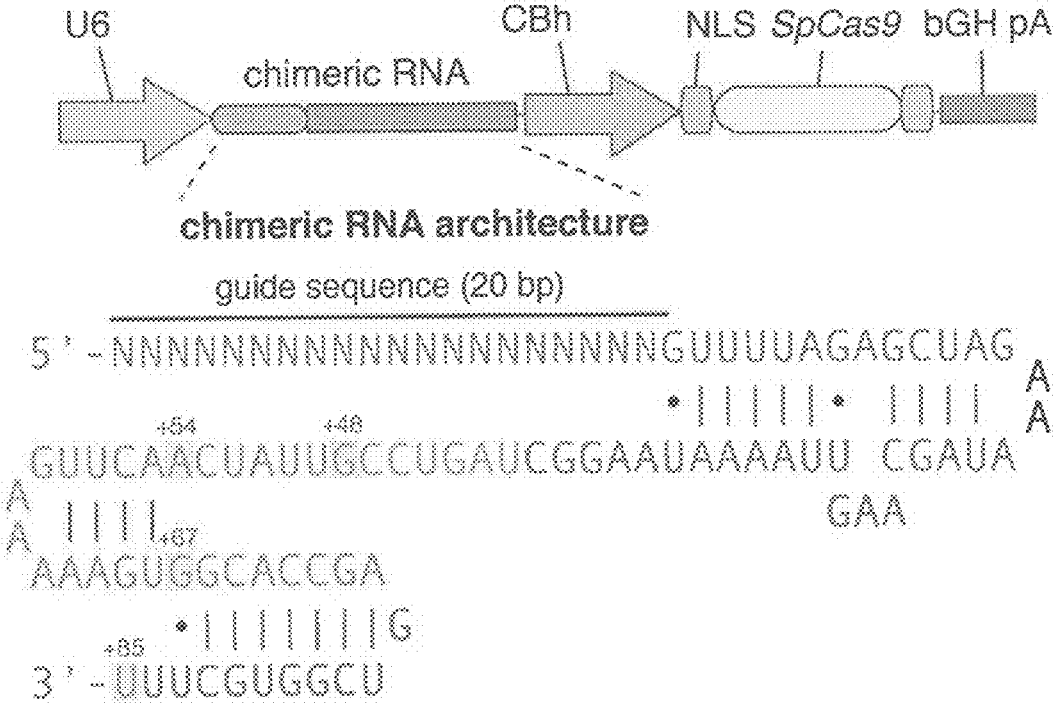

FIG. 18A

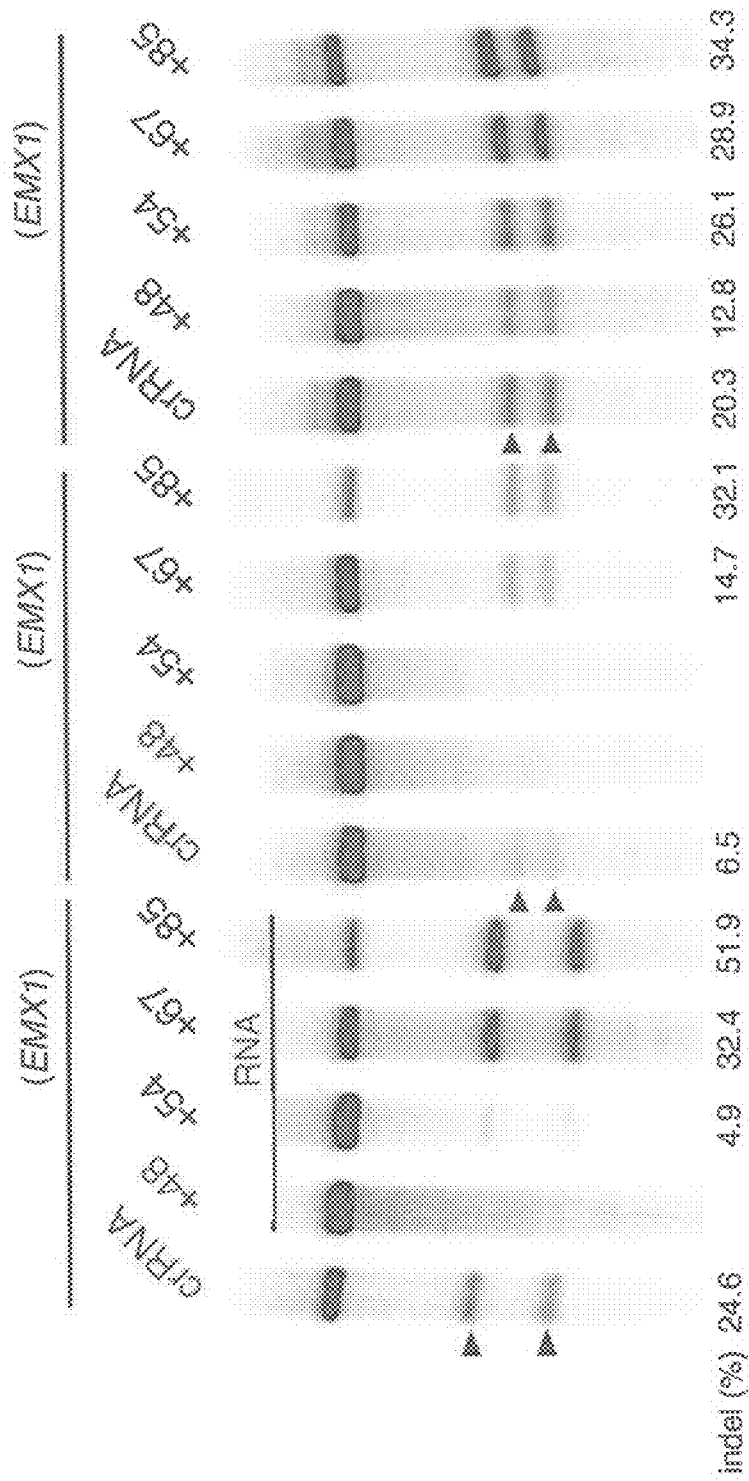

FIG. 18B

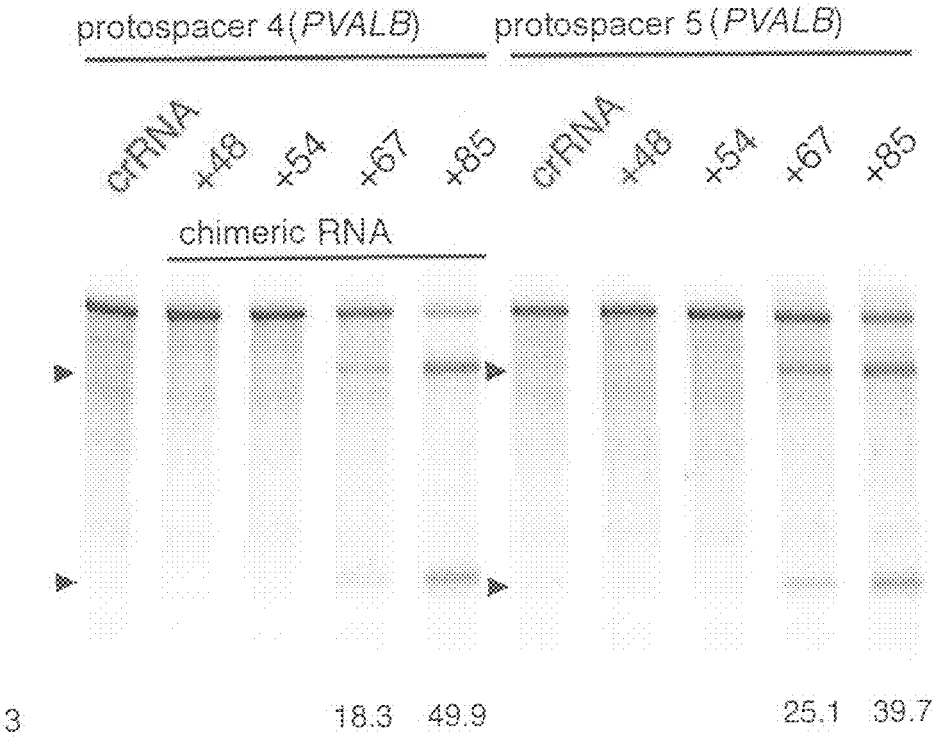

FIG. 18C

FIG. 19B

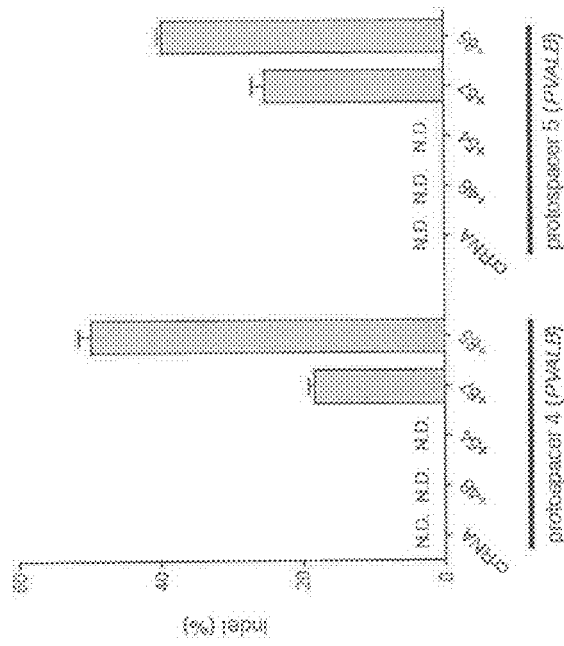
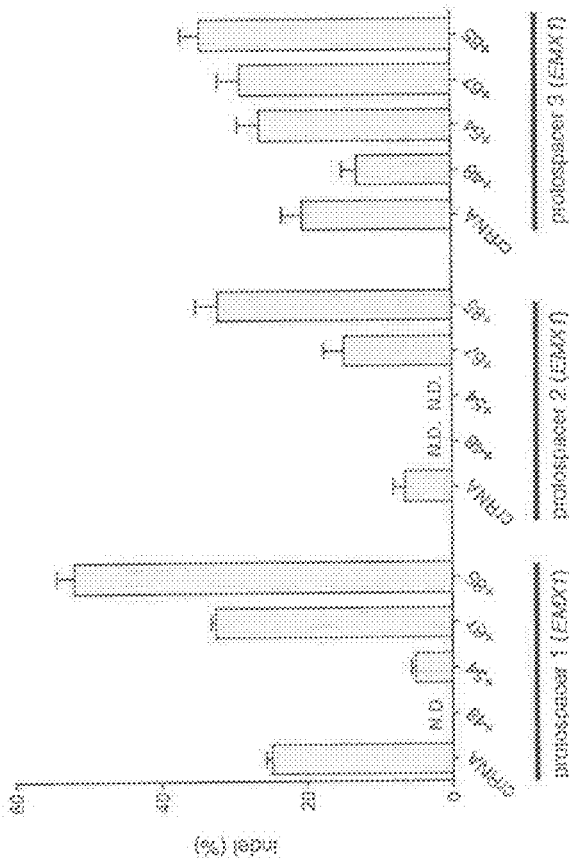

FIG. 19A



UCSC Genome Browser on Human Feb. 2009 (GRCh37/hg19) Assembly

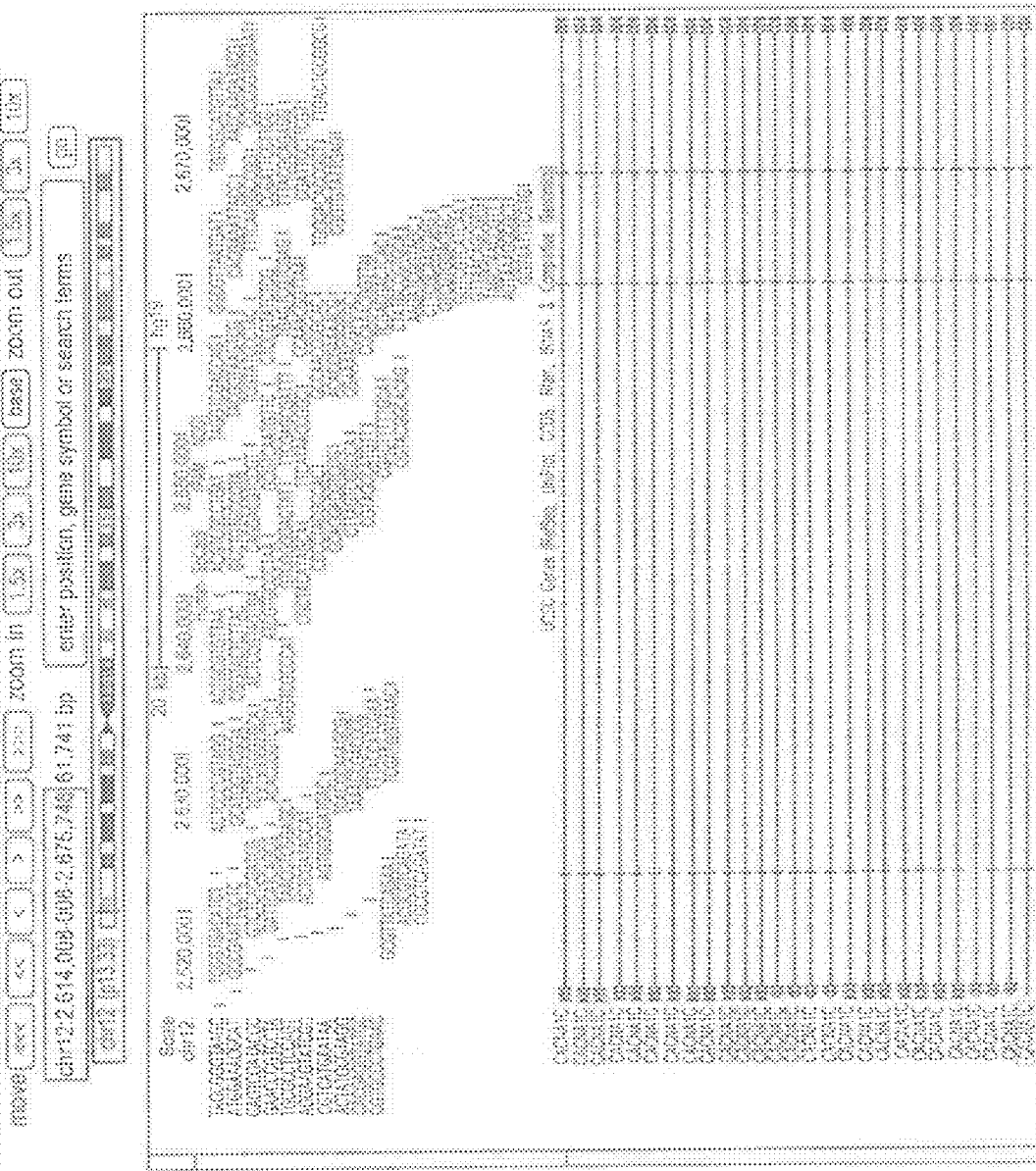

FIG. 20

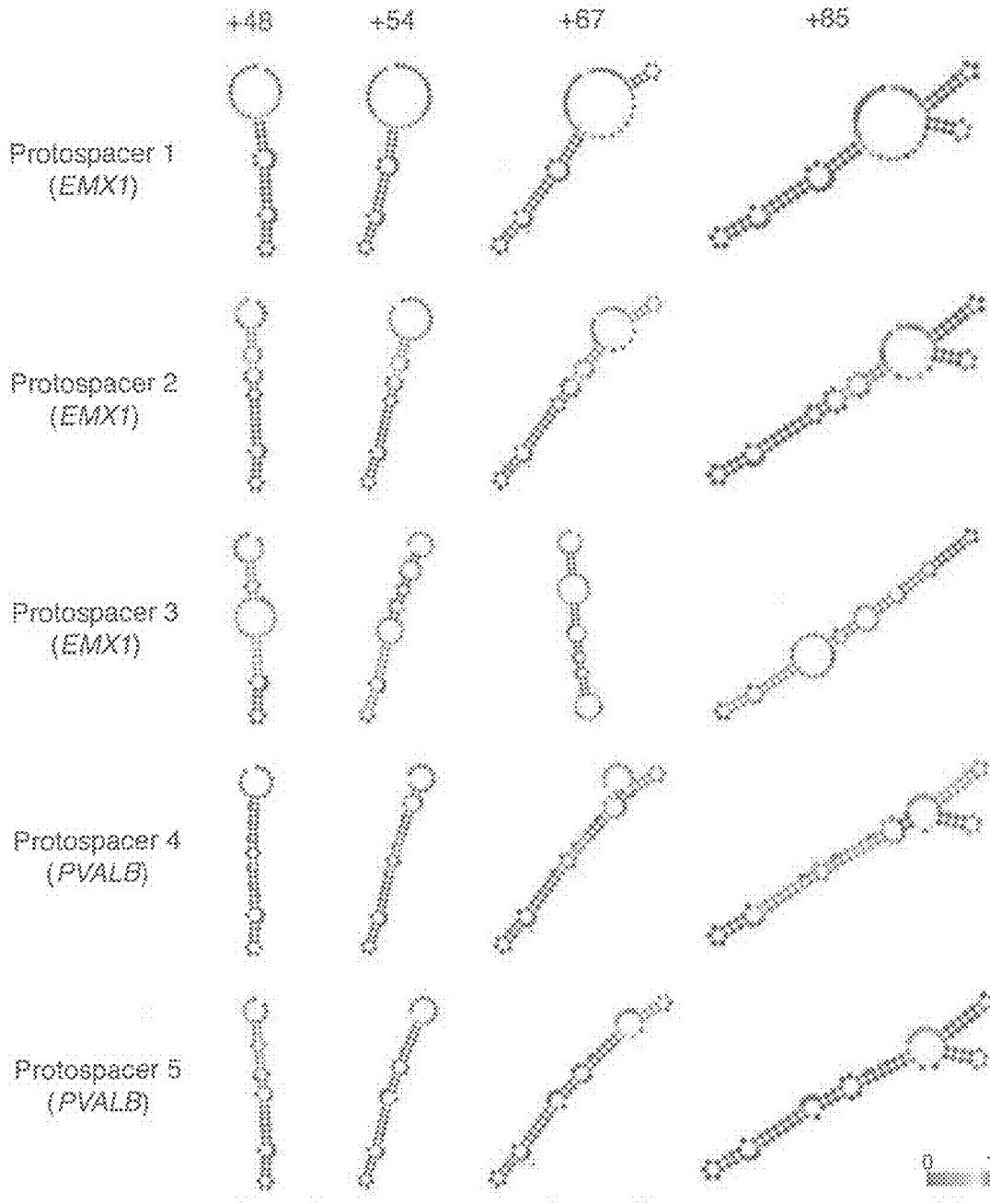
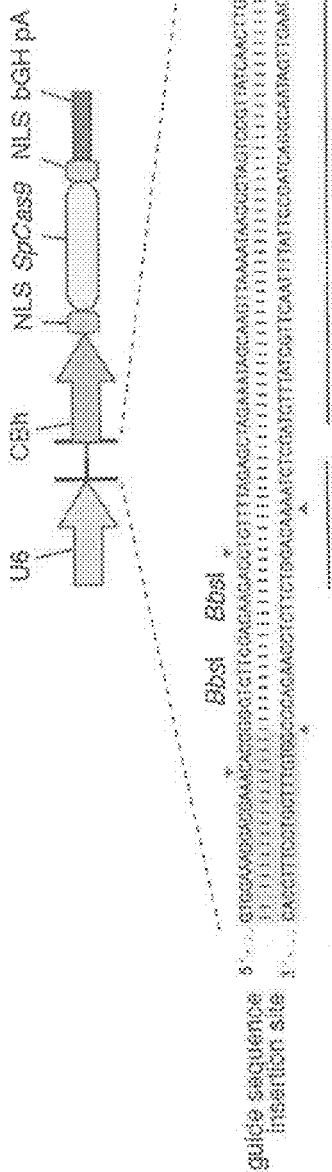

FIG. 21



guide sequence
insertion site

5' ...
3' ...

guide sequence
insert

5' ...
3' ...

FIG. 22

FIG. 23A

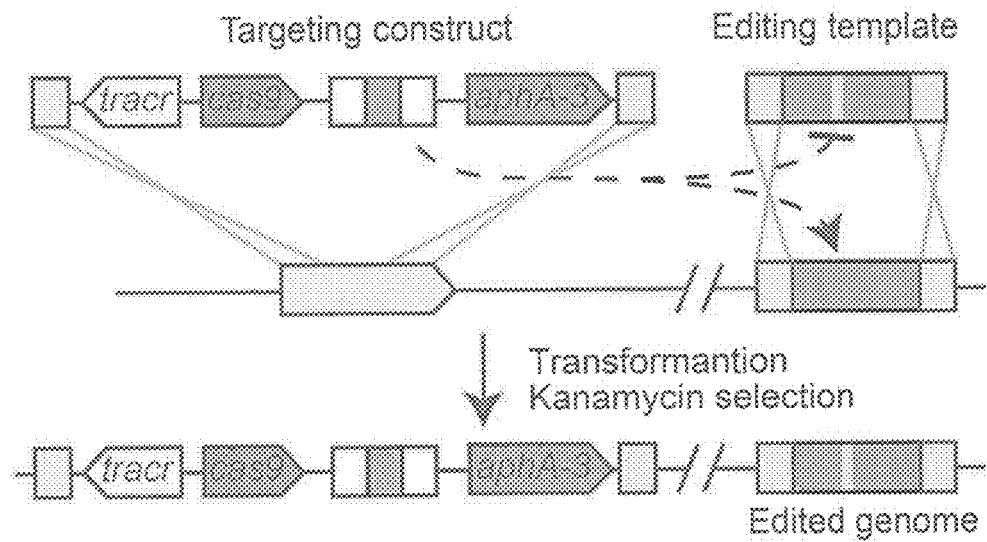

FIG. 23B

Editing Construct	cfu/ug of crR6M DNA	Kan ^r transformants	
		Ed. Un.	
None	2.6 ± 0.9	[Gel image showing low number of transformants]	
R6(<i>srtA</i>)	14 ± 1.8	[Gel image showing moderate number of transformants]	
R6 ^{370.1}	25 ± 2.6	[Gel image showing high number of transformants]	

FIG. 24A

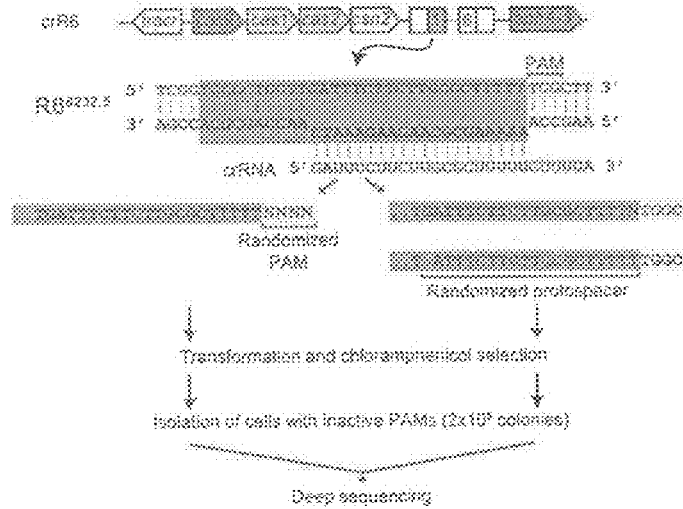

FIG. 24B

		2 nd PAM position								
		A		C		G		T		
1 st PAM position	A	AAA	1.02	ACA	1.06	AGA	0.95	ATA	1.02	3 rd PAM position
	C	CAB	1.03	CCA	1.03	CGA	0.97	CTA	1.00	
	G	GAA	1.10	GCA	1.09	GGA	0.93	GTA	1.01	
	T	TAA	1.02	TCA	1.11	TGA	0.91	TTA	1.11	
1 st PAM position	A	AAC	1.07	ACC	1.02	AGC	1.00	ATC	1.09	3 rd PAM position
	C	CAC	1.06	CCC	1.04	CGC	1.00	CTC	1.08	
	G	GAC	1.05	GCC	1.02	GGC	1.02	GTC	1.22	
	T	TAC	1.05	TCC	1.05	TGC	1.03	TTC	1.06	
1 st PAM position	A	AAG	0.99	ACG	0.97	AGG	0.96	ATG	0.96	3 rd PAM position
	C	CAG	0.99	CCG	1.08	CGG	0.98	CTG	1.03	
	G	GAG	0.99	GCG	1.08	GGG	0.98	GTG	1.20	
	T	TAG	0.95	TCG	0.91	TGG	0.97	TTG	1.06	
1 st PAM position	A	AAT	1.01	ACT	1.09	AGT	1.04	ATT	1.03	3 rd PAM position
	C	CAT	1.03	CCT	1.03	CGT	1.07	CTT	1.08	
	G	GAT	1.04	GCT	1.08	GGT	1.08	GTT	1.12	
	T	TAT	1.06	TCT	1.03	TGT	1.06	TTT	1.01	

FIG. 24C

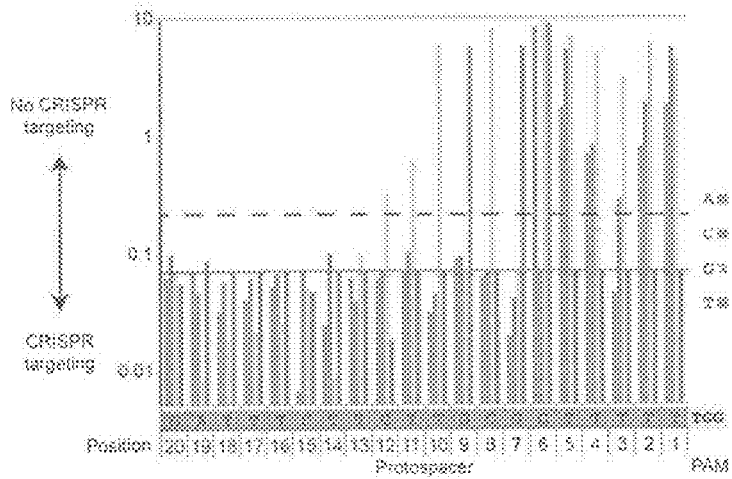

FIG. 25A

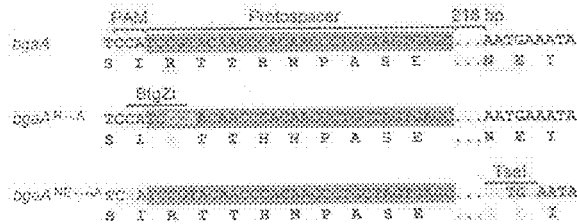

FIG. 25B

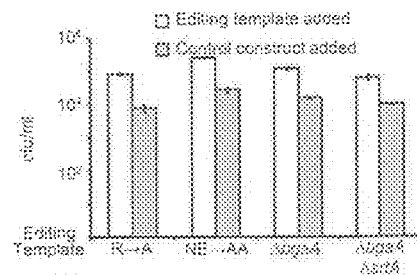

FIG. 25C

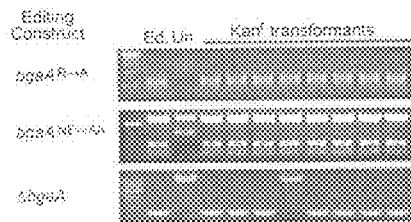

FIG. 25D

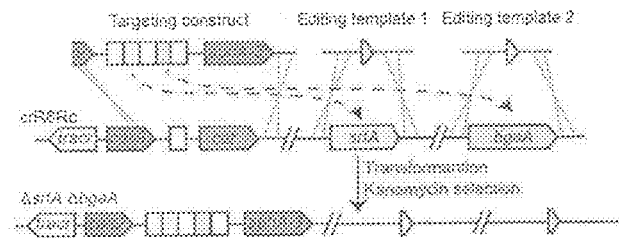
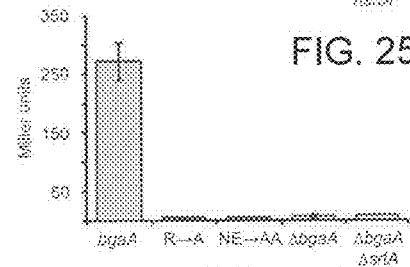

FIG. 25E



FIG. 25F

FIG. 26A

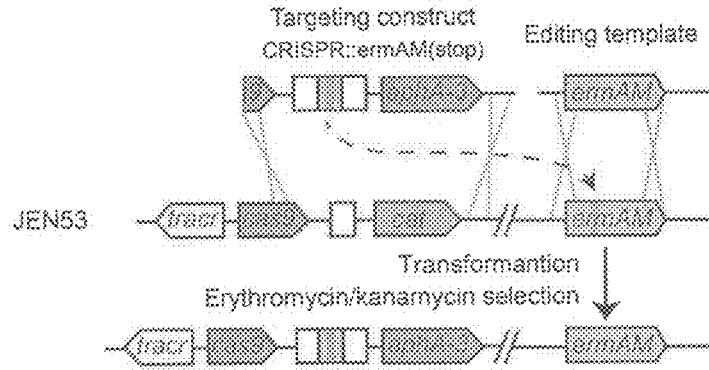

FIG. 26B

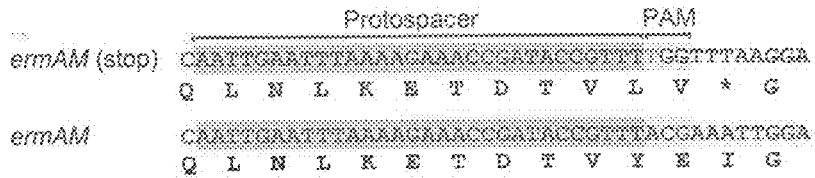

FIG. 26C

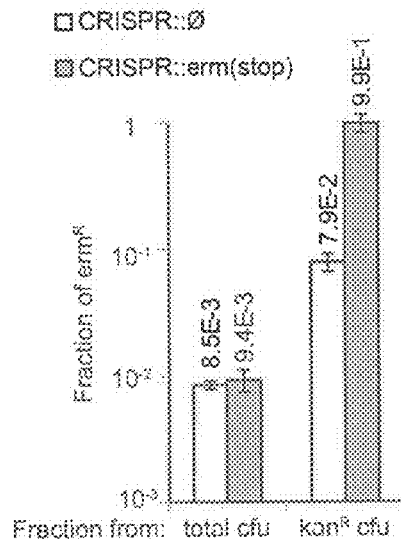

FIG. 26D

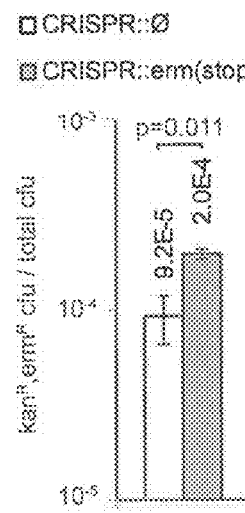

FIG. 27A

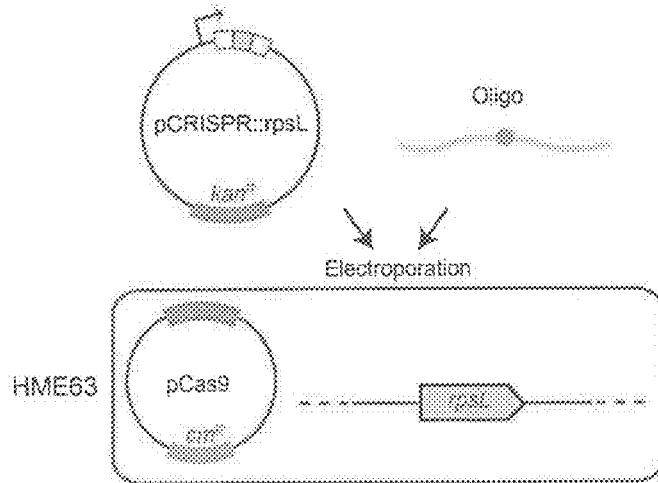

FIG. 27B

	PAM	Protospacer
<i>rpsL</i>	TCCTA	AAAAACCGAAGCTCCGGCCCTGGCGTAAAGTA
	P	K K P N S A L R K V
<i>rpsL mut</i>	TCCTA	AAAAACCGAAGCTCCGGCCCTGGCGTAAAGTA
	P	T K P N S A L R K V

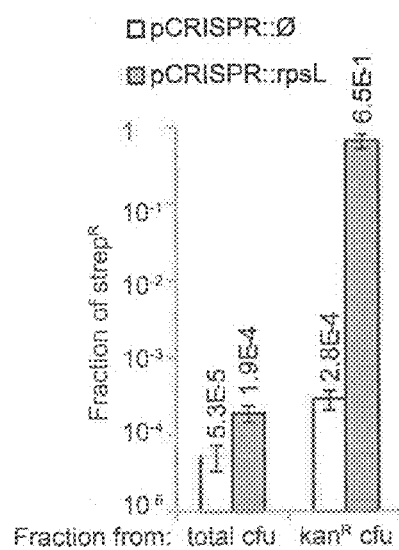

FIG. 27C

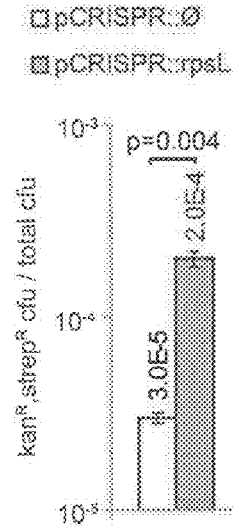

FIG. 27D

FIG. 28A

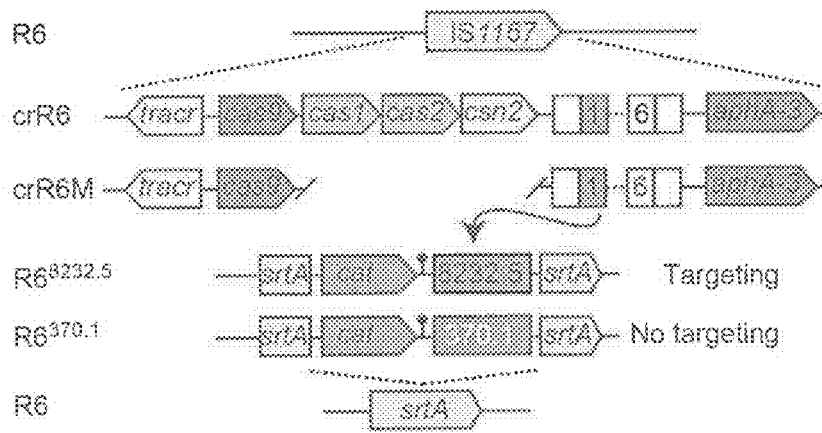

FIG. 28B

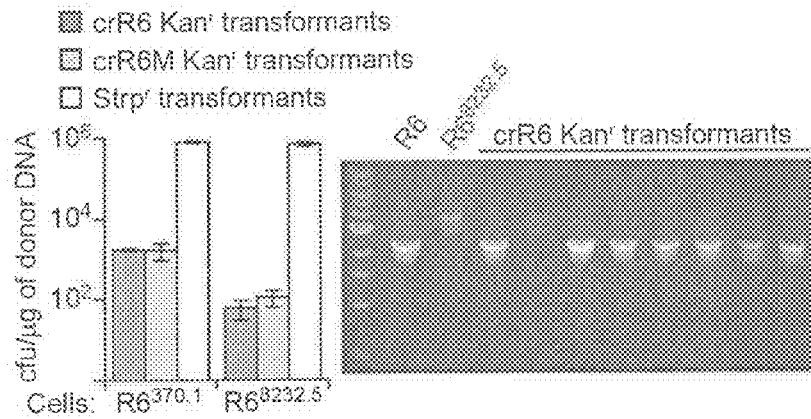

FIG. 29A

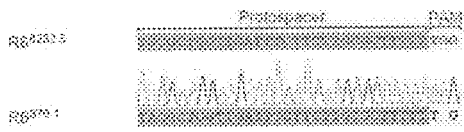

FIG. 29B

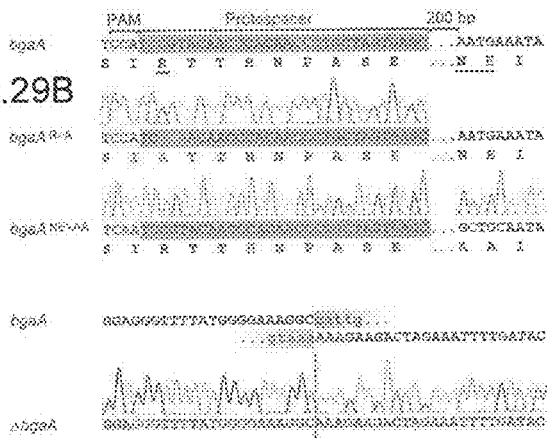

FIG. 29C

FIG. 29D



FIG. 29E

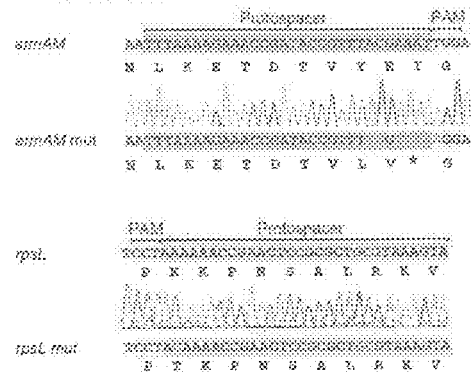

FIG. 29F

FIG. 30A

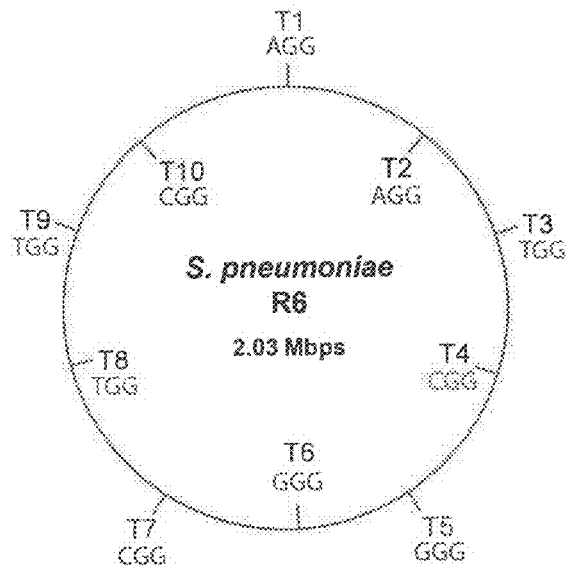

FIG. 30B

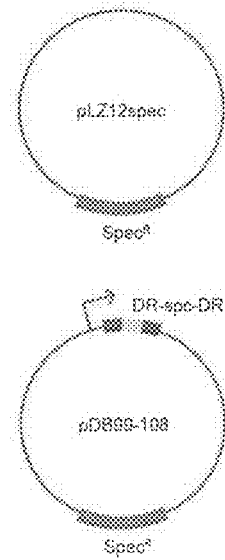
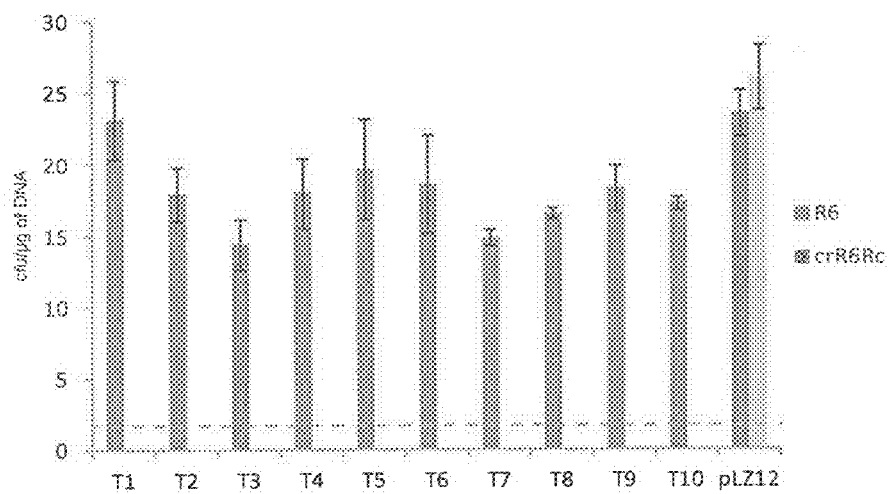

FIG. 30C



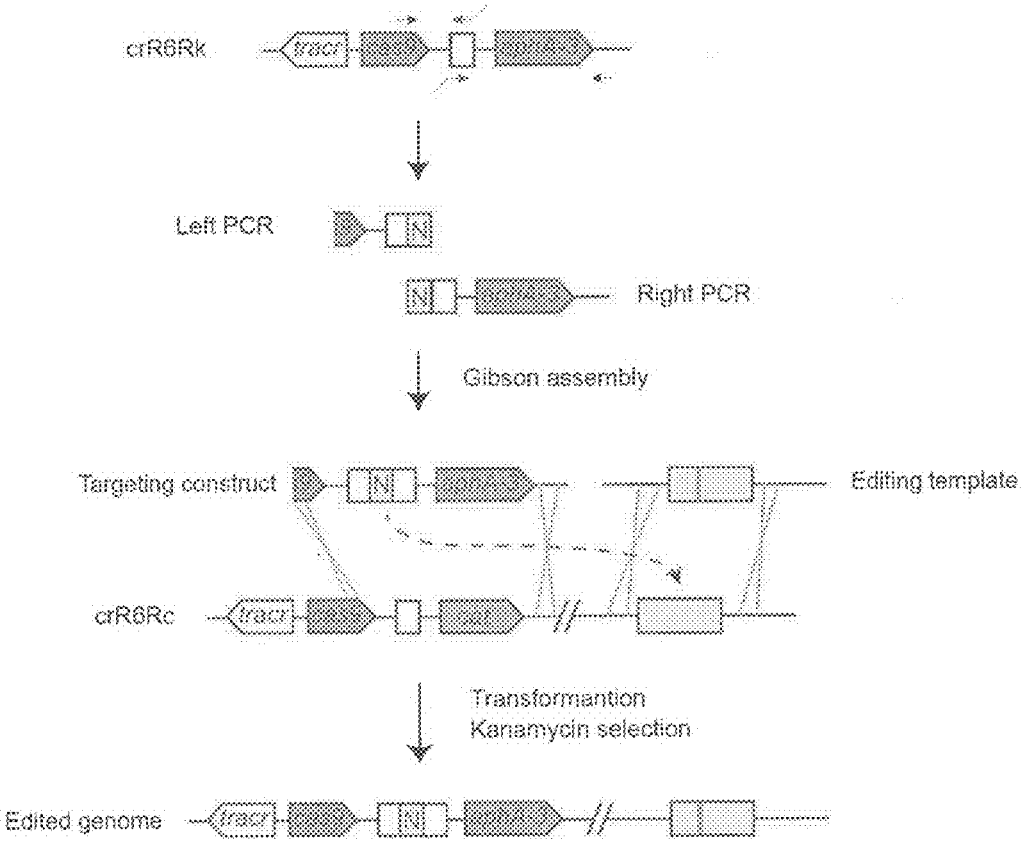

FIG. 31

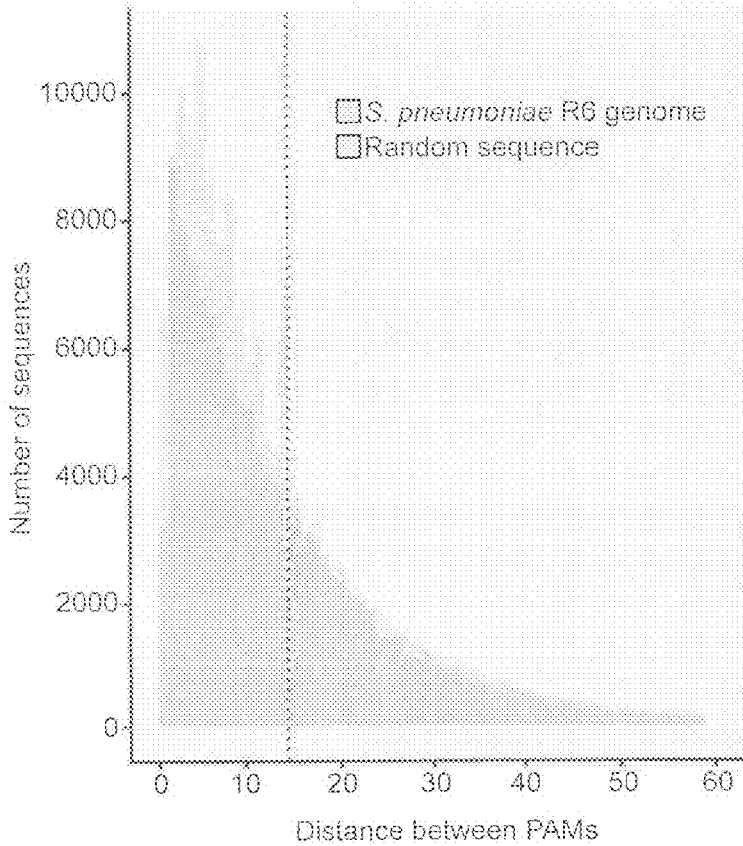

FIG. 32

FIG. 33A

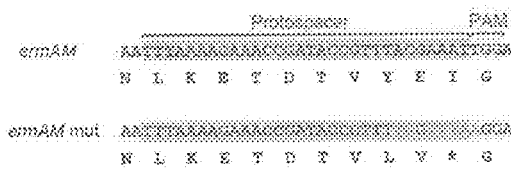

FIG. 33B

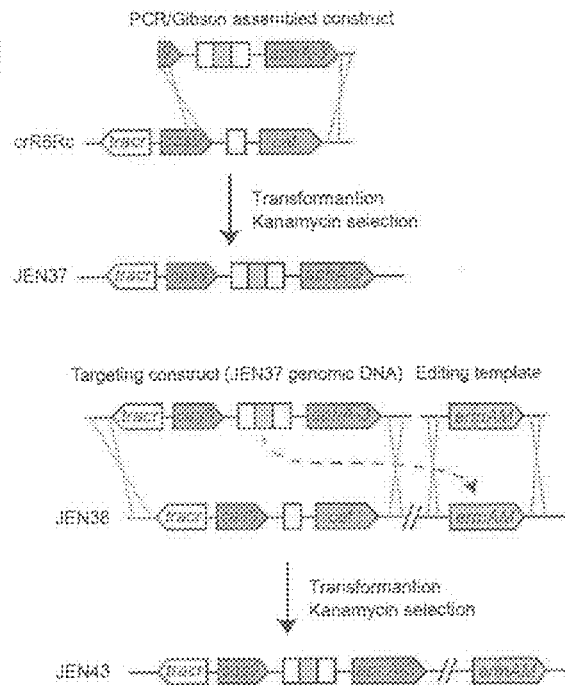

FIG. 33C

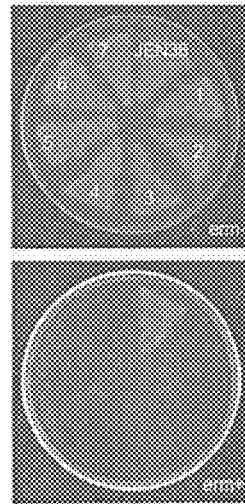
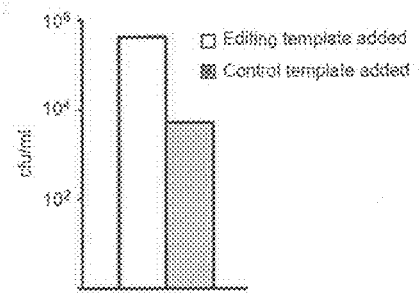

FIG. 33D

FIG. 34A

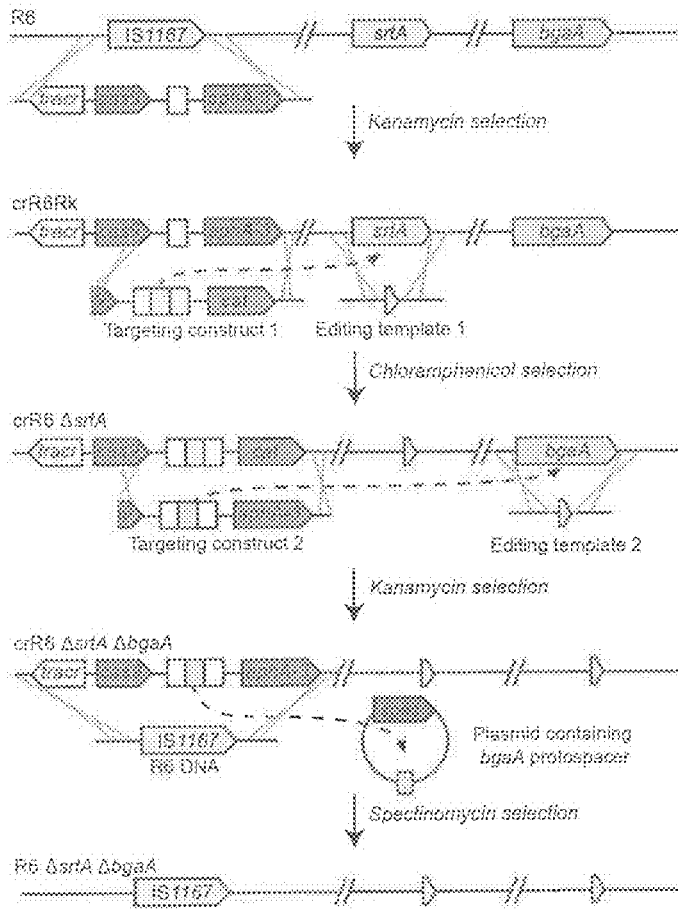

FIG 34B

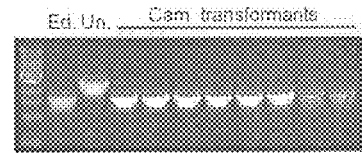

FIG. 34C

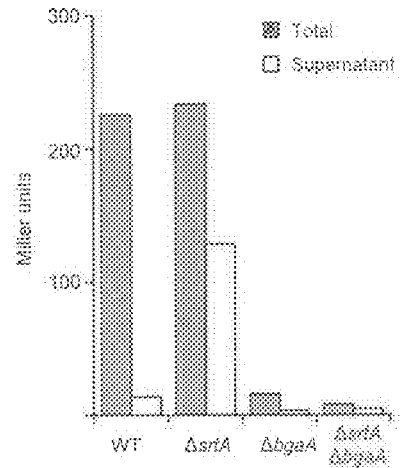

FIG. 34D

FIG. 35A

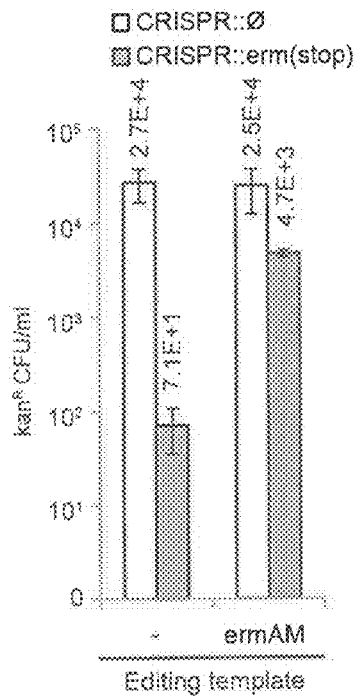

FIG. 35B

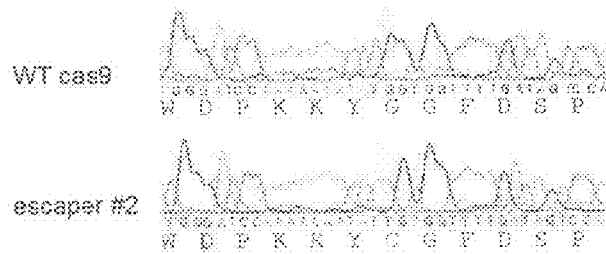
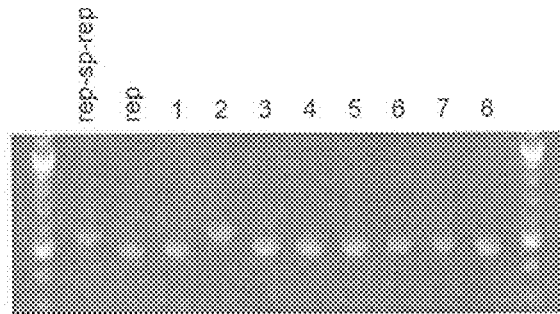

FIG. 35C

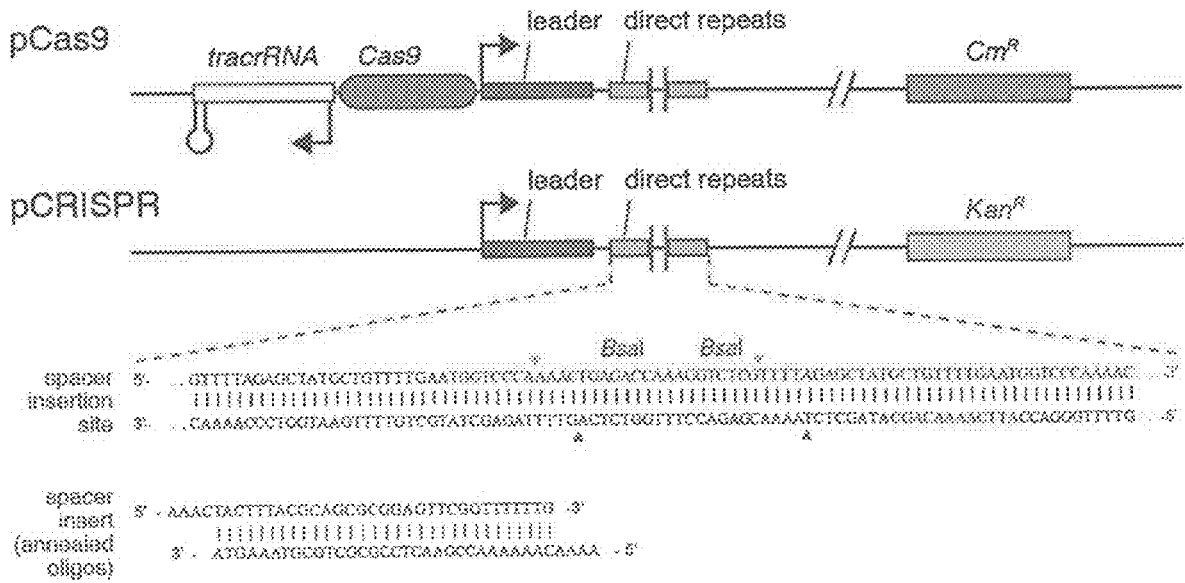

FIG. 36

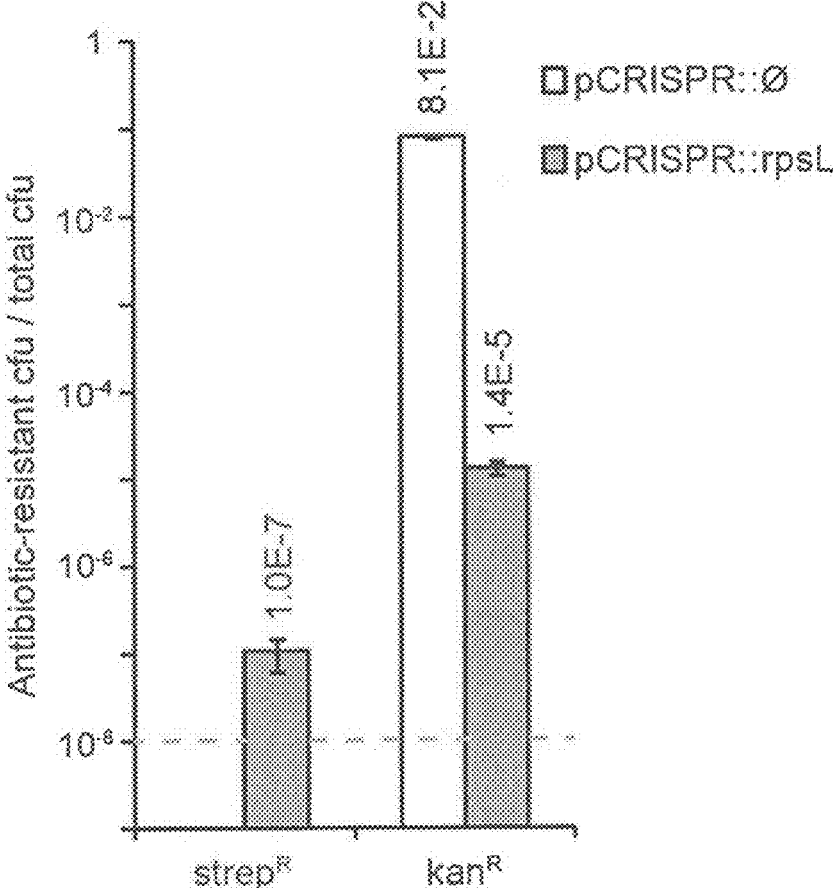

FIG. 37

FIG. 38A

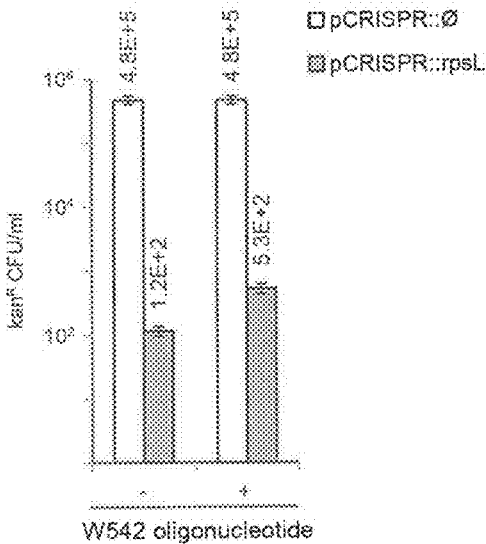
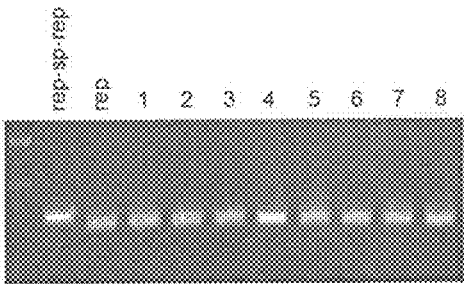

FIG. 38B



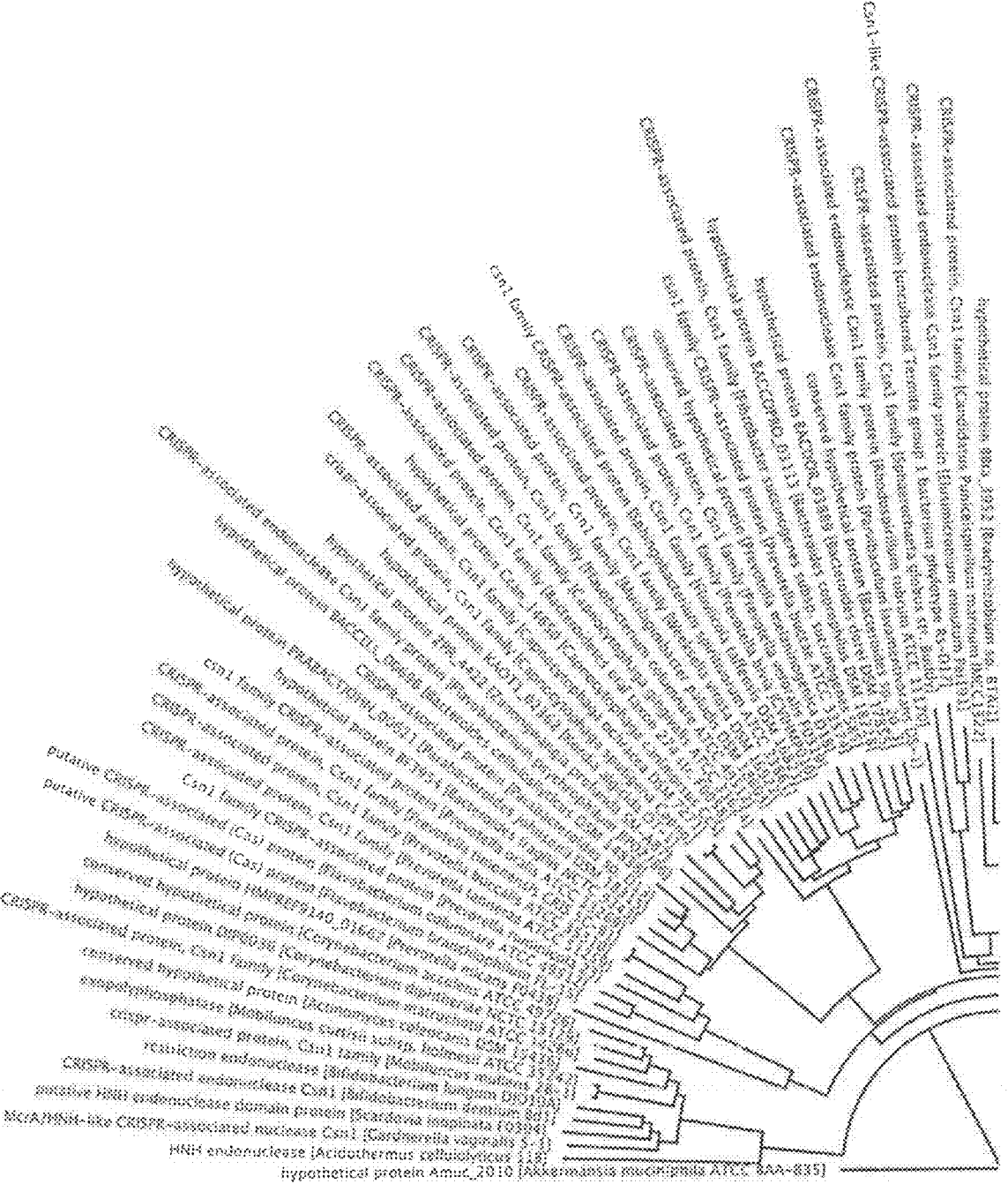

FIG. 39A



FIG. 40A

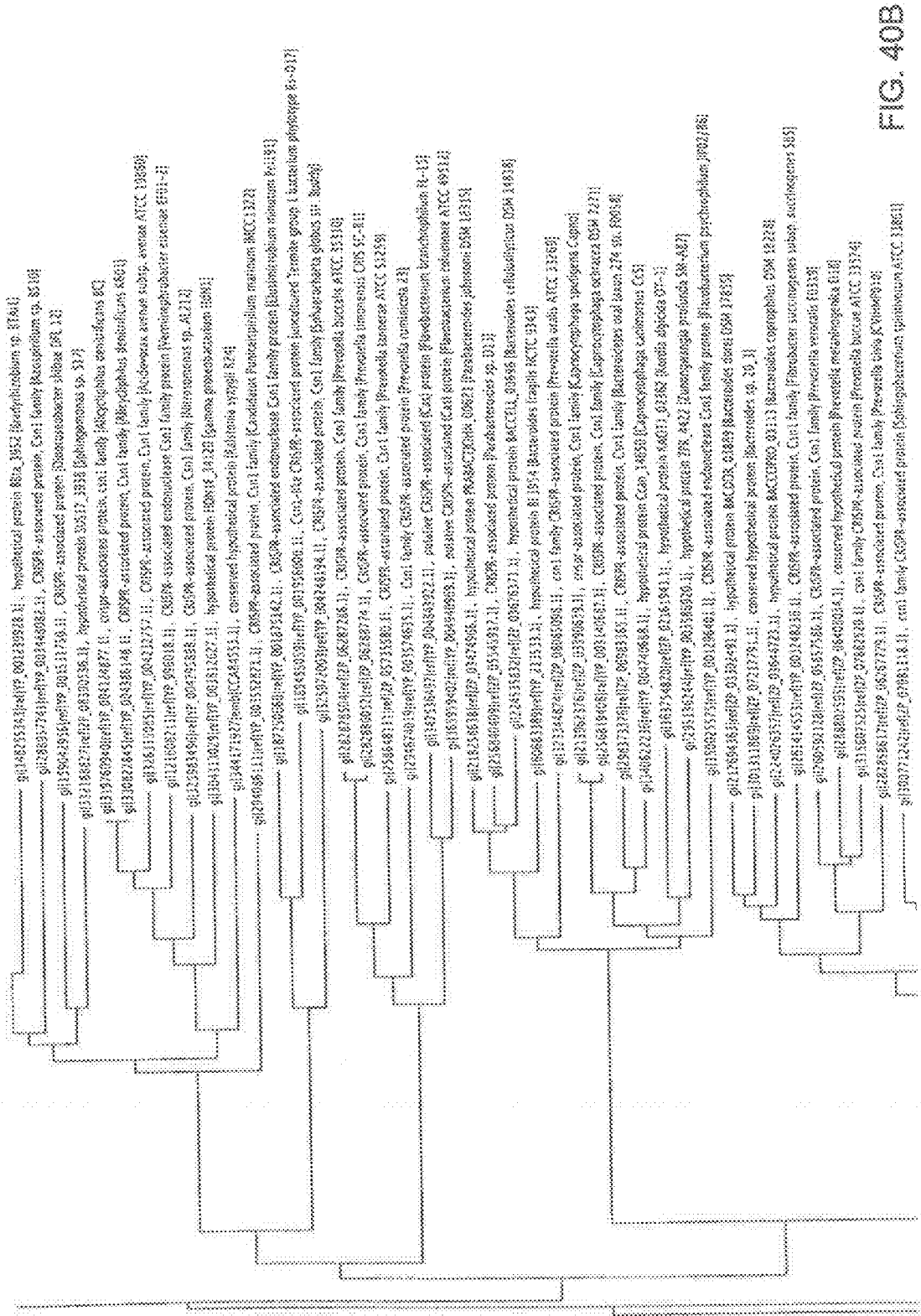

FIG. 40B

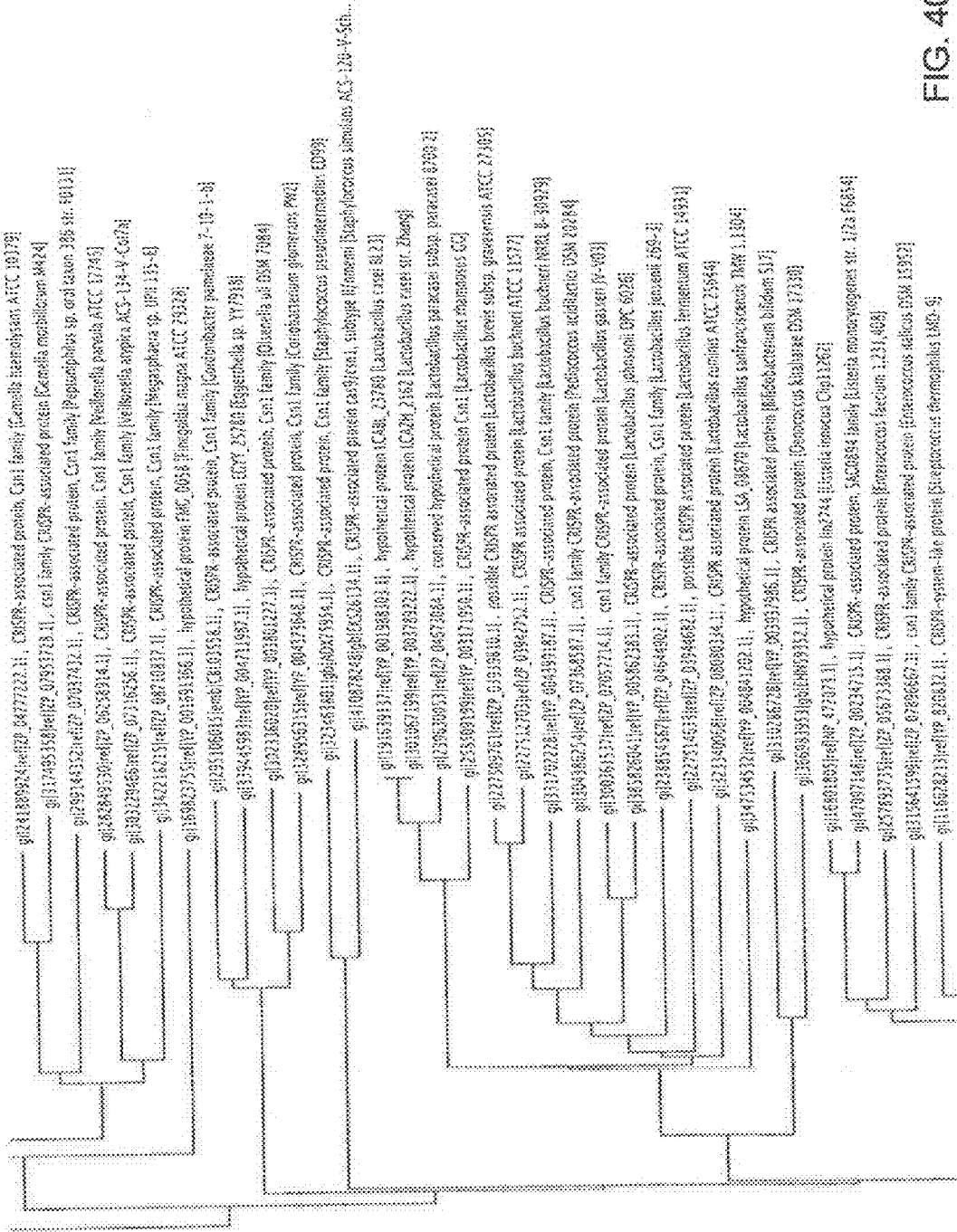

FIG. 40E

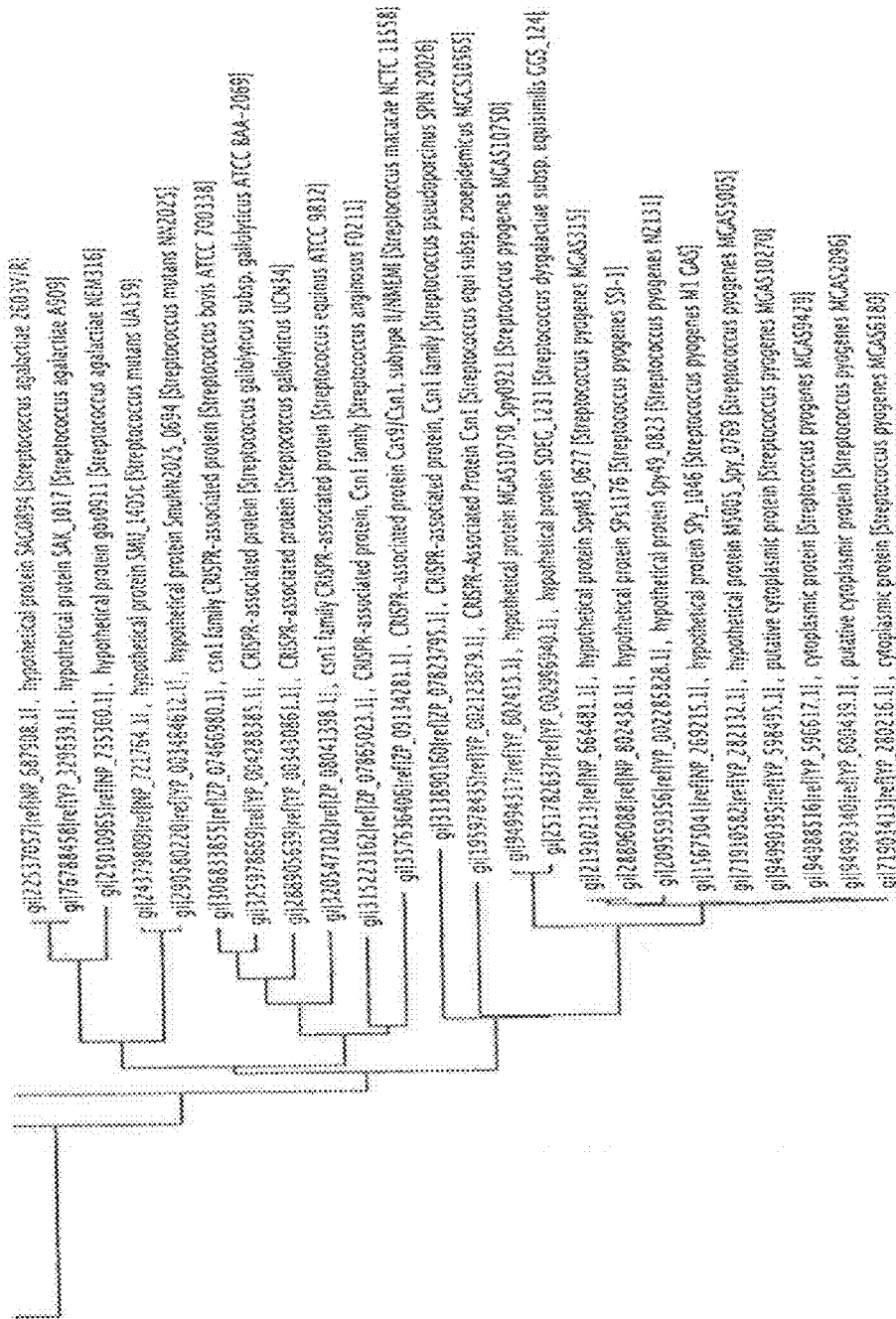

FIG. 40F

SpCas9 mutation positions

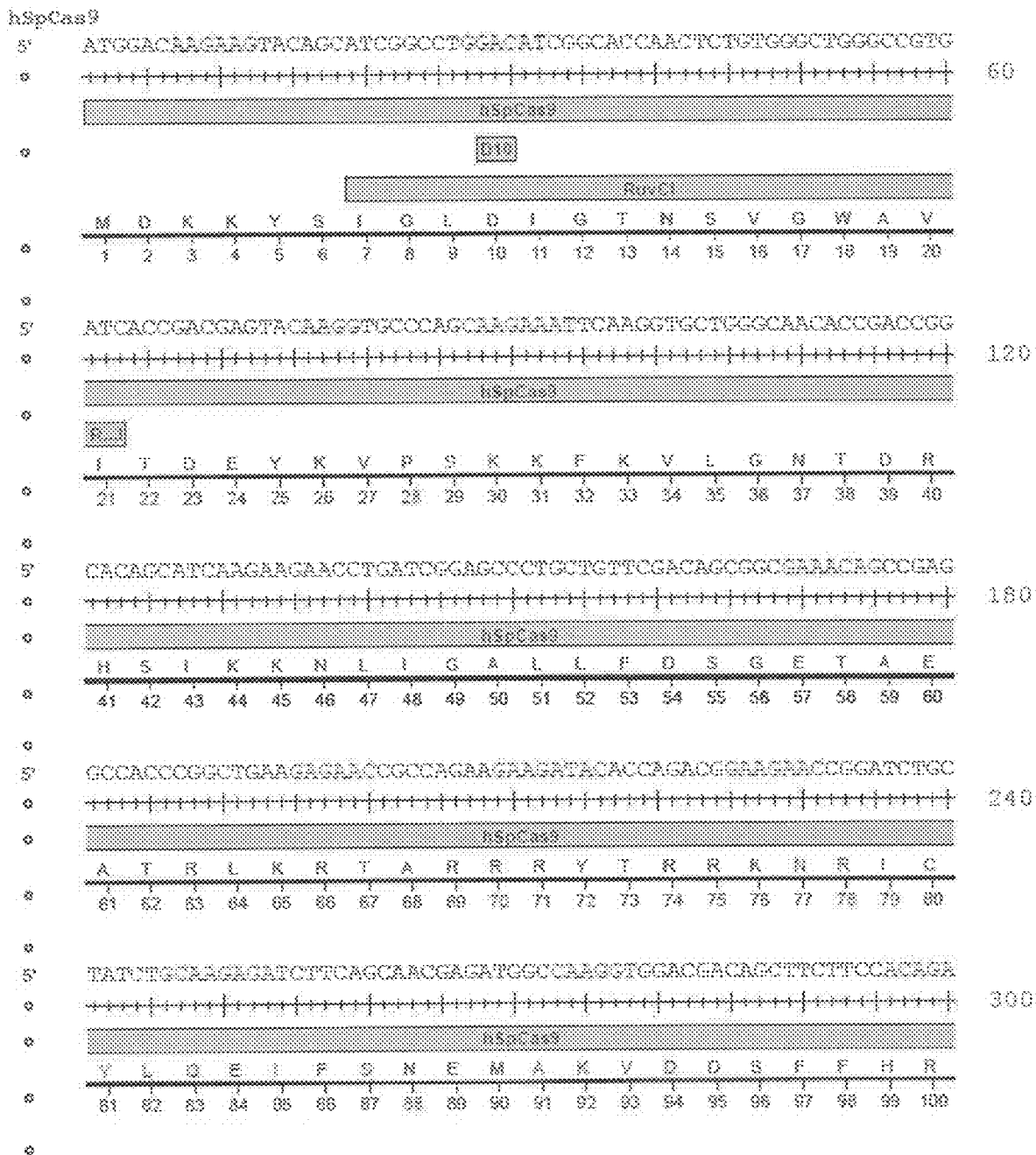

FIG. 41A

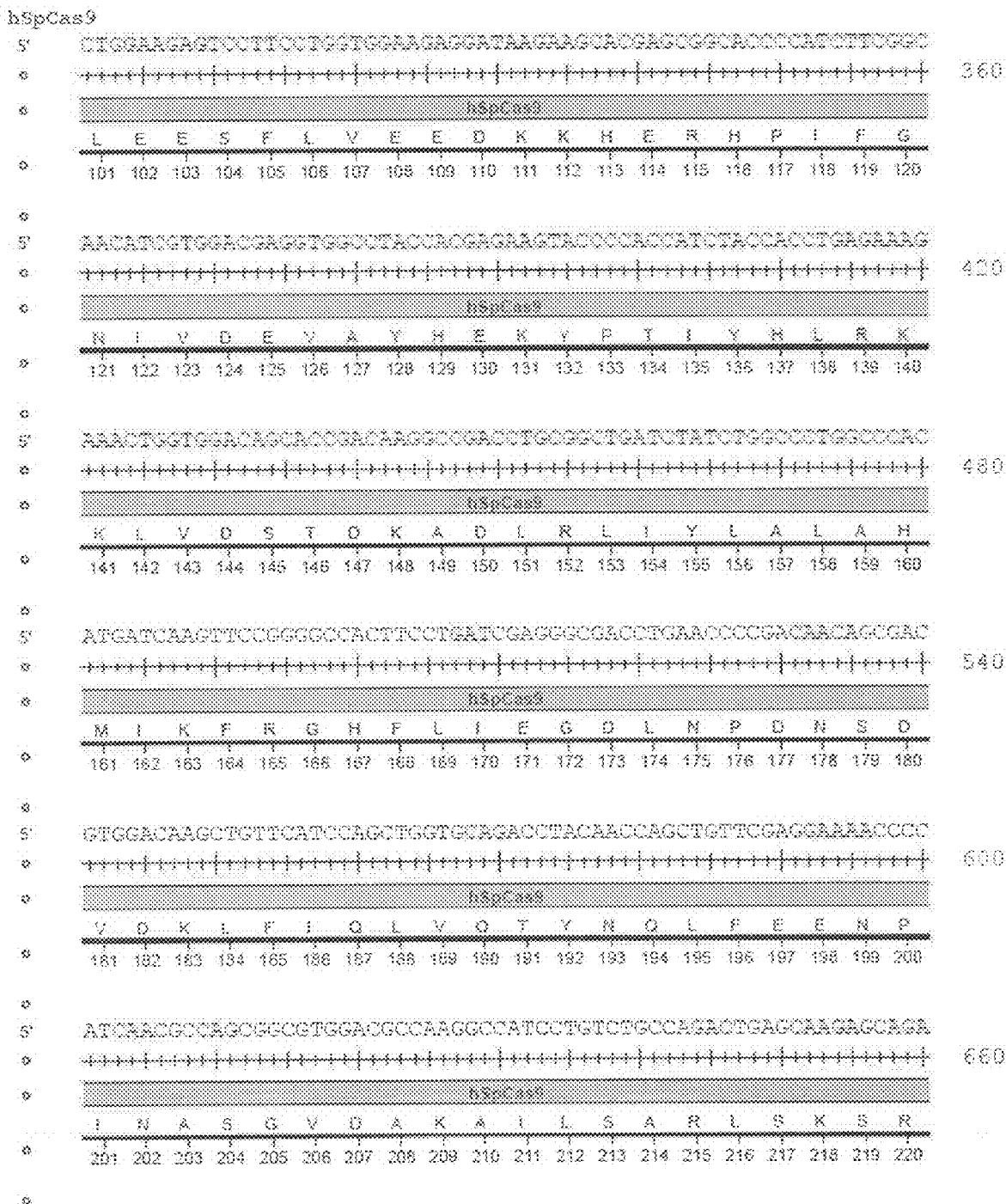

FIG. 41B

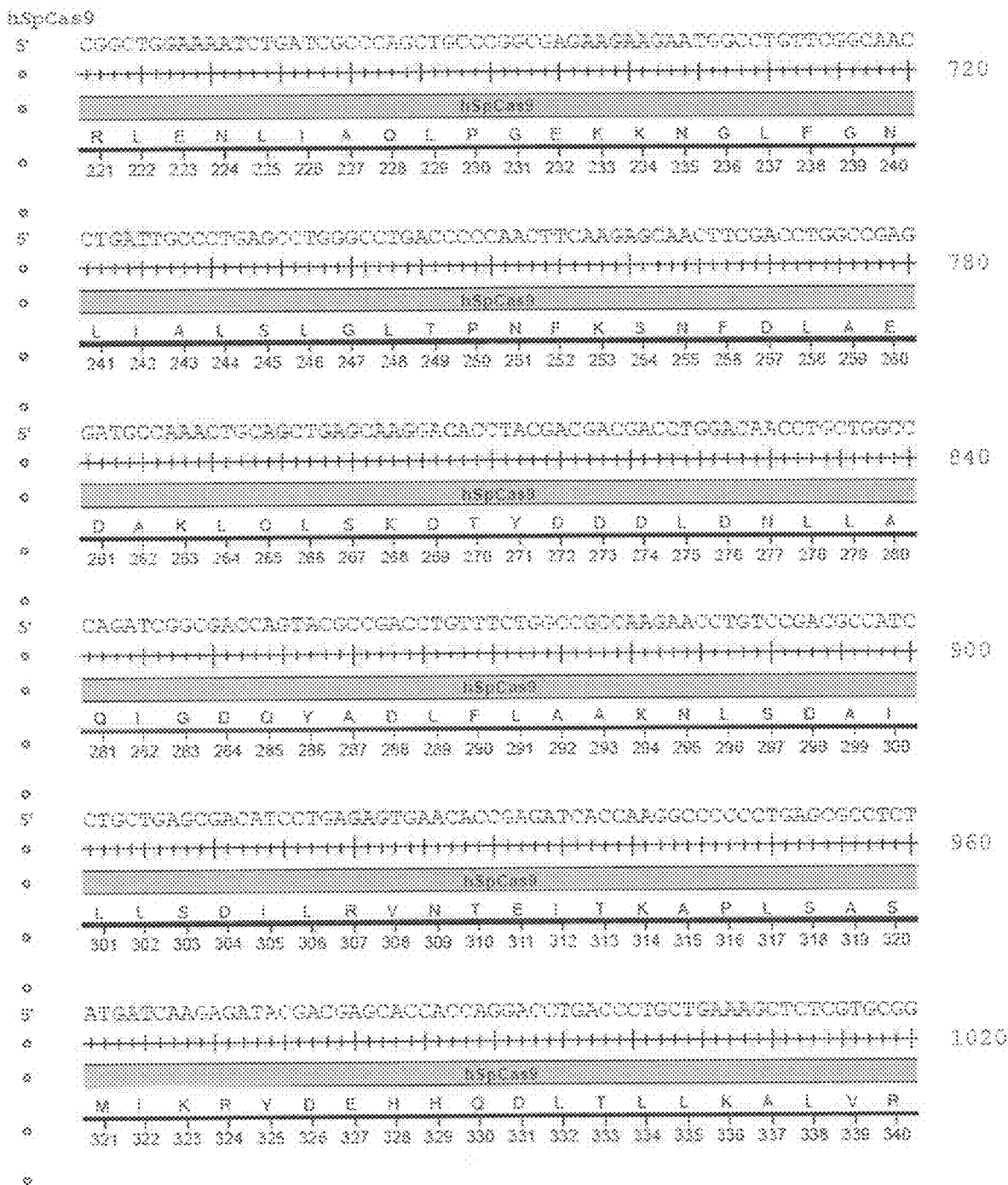

FIG. 41C

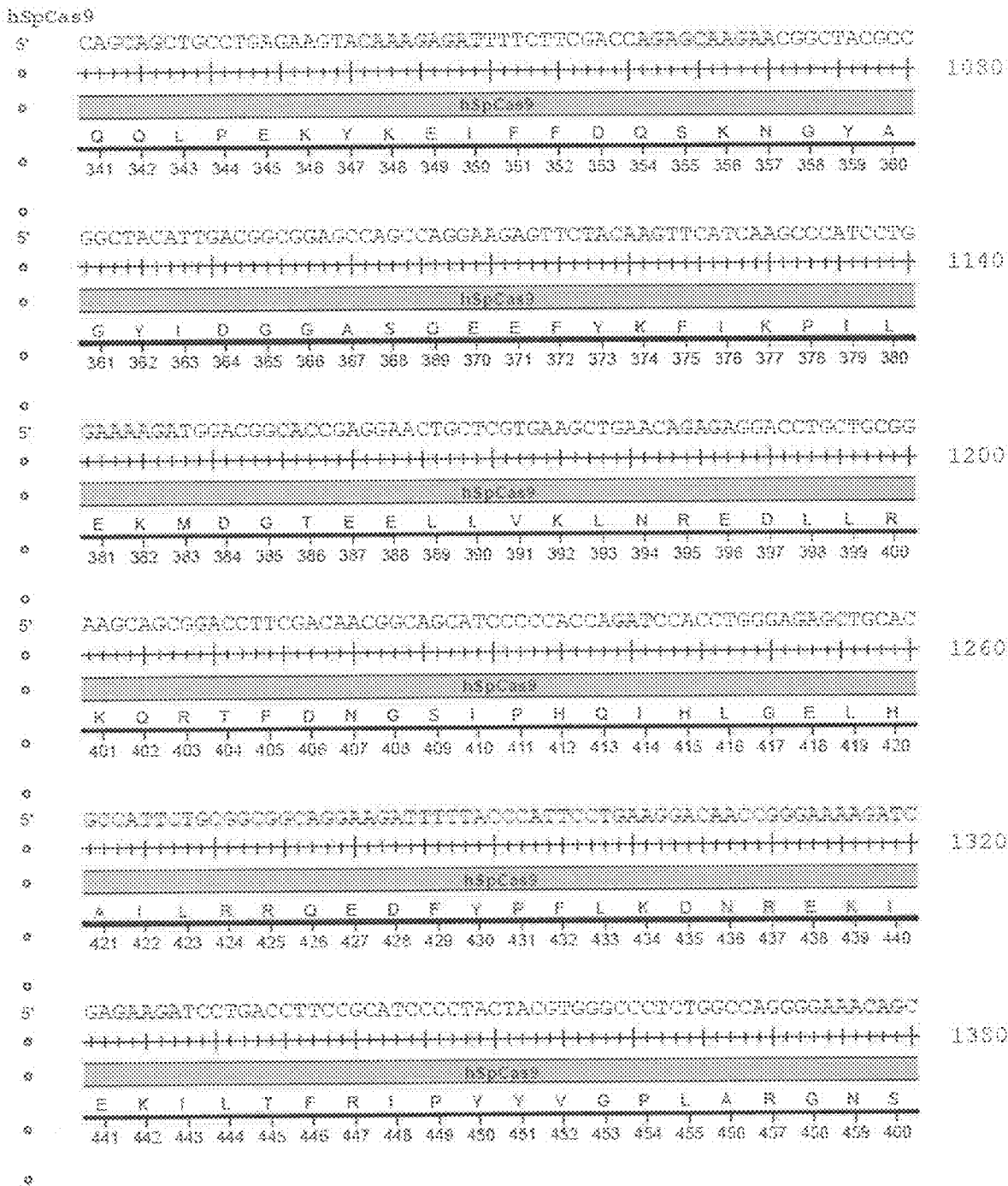

FIG. 41D

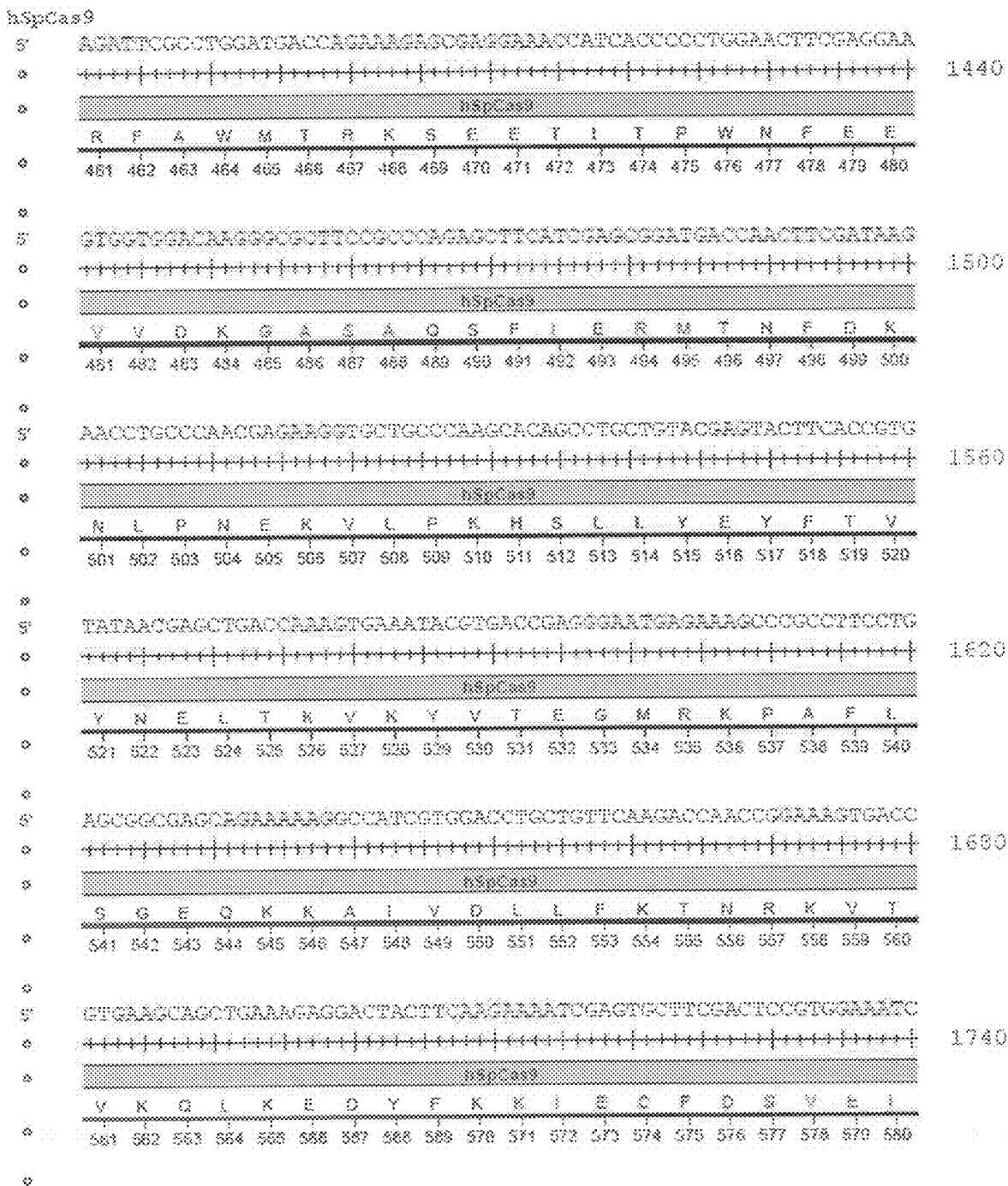

FIG. 41E

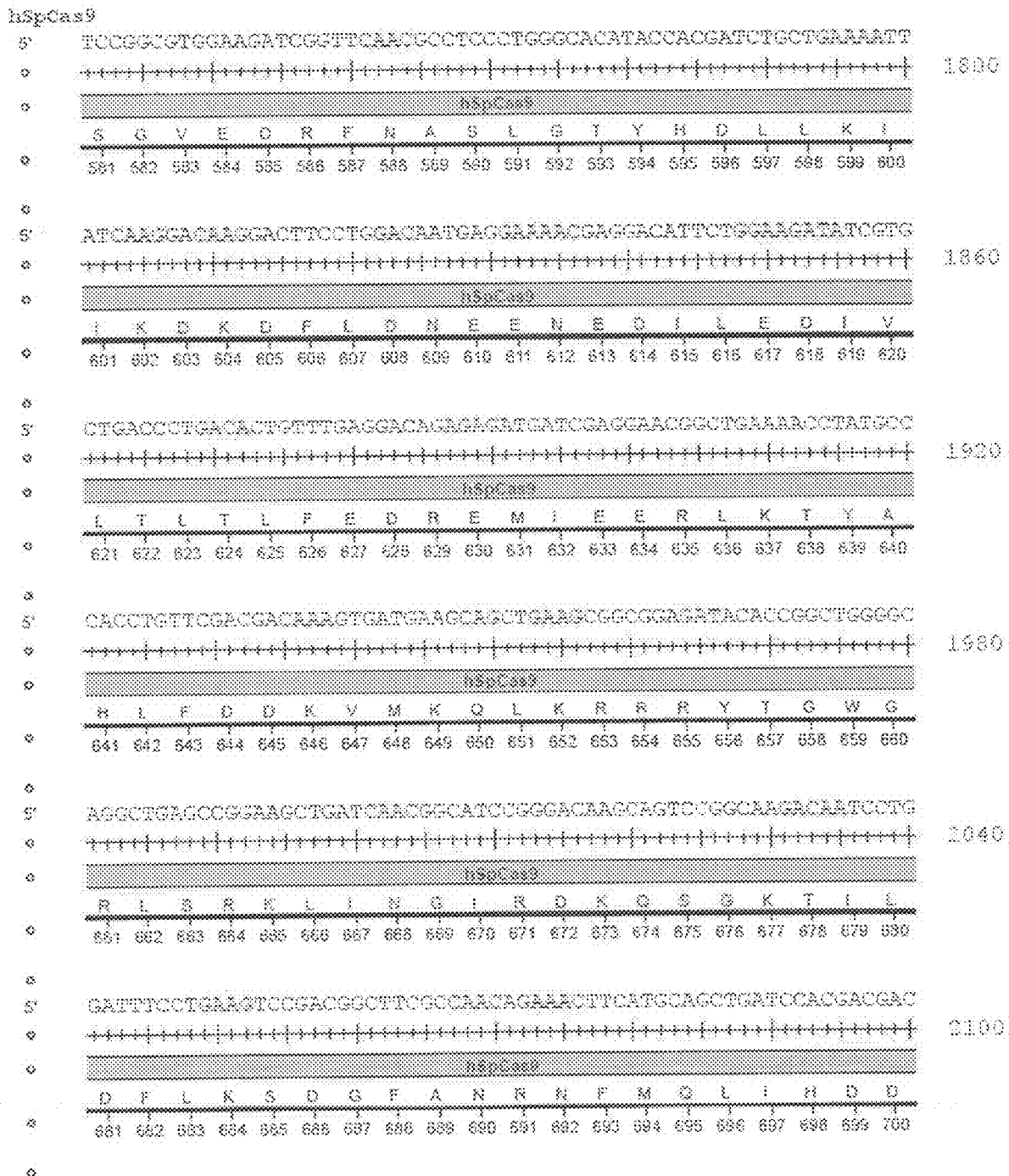

FIG. 41F

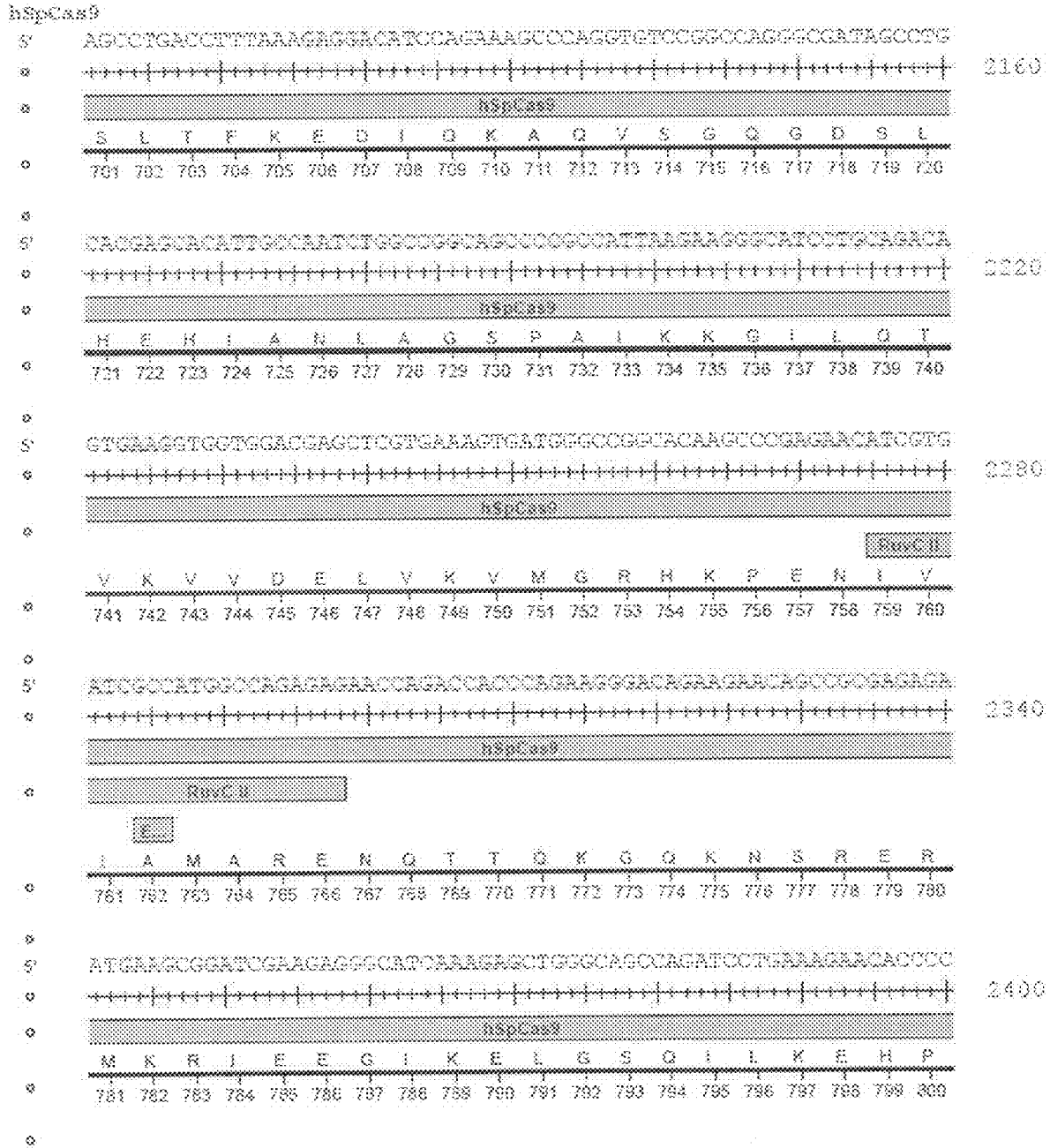

FIG. 41G

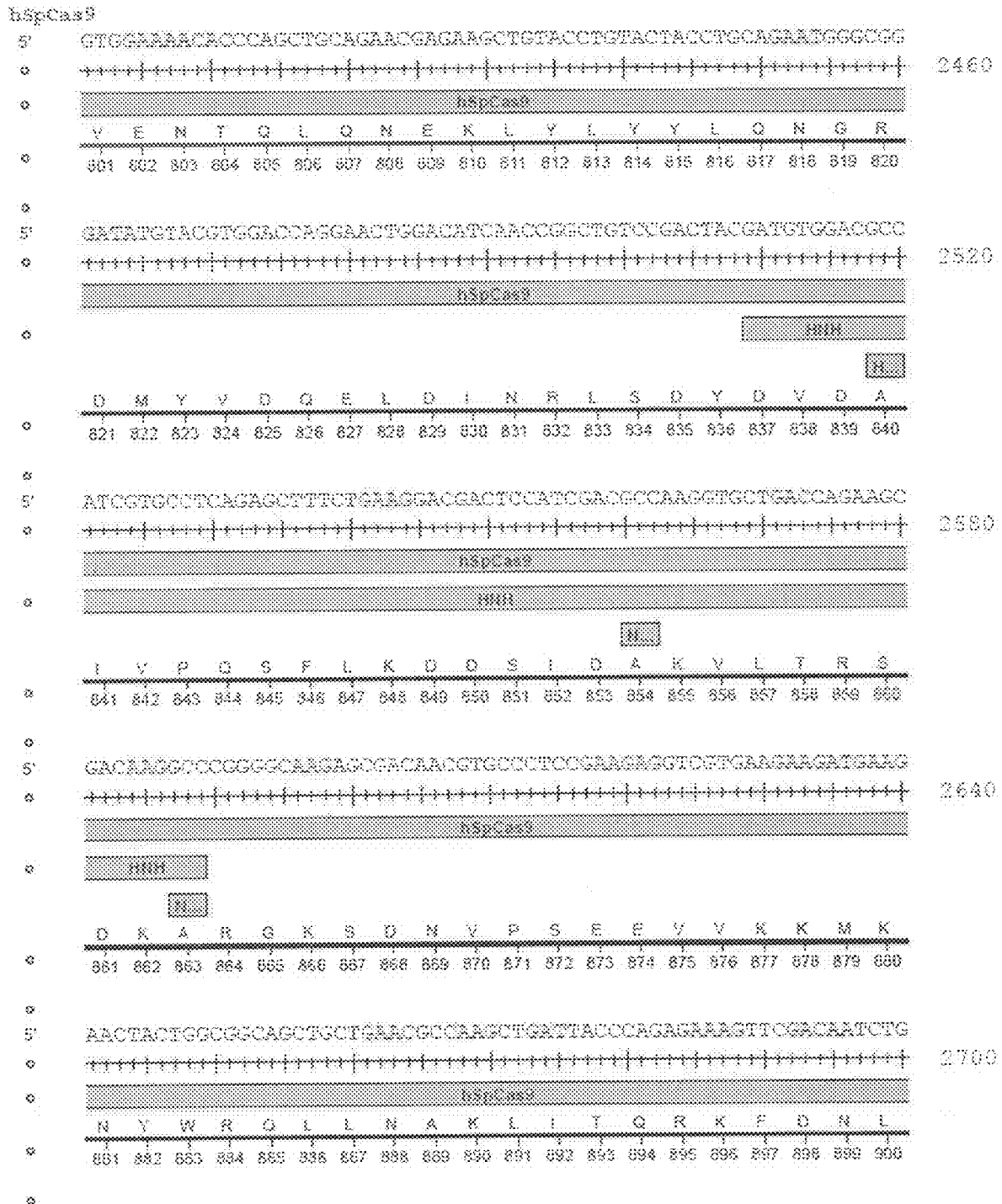

FIG. 41H

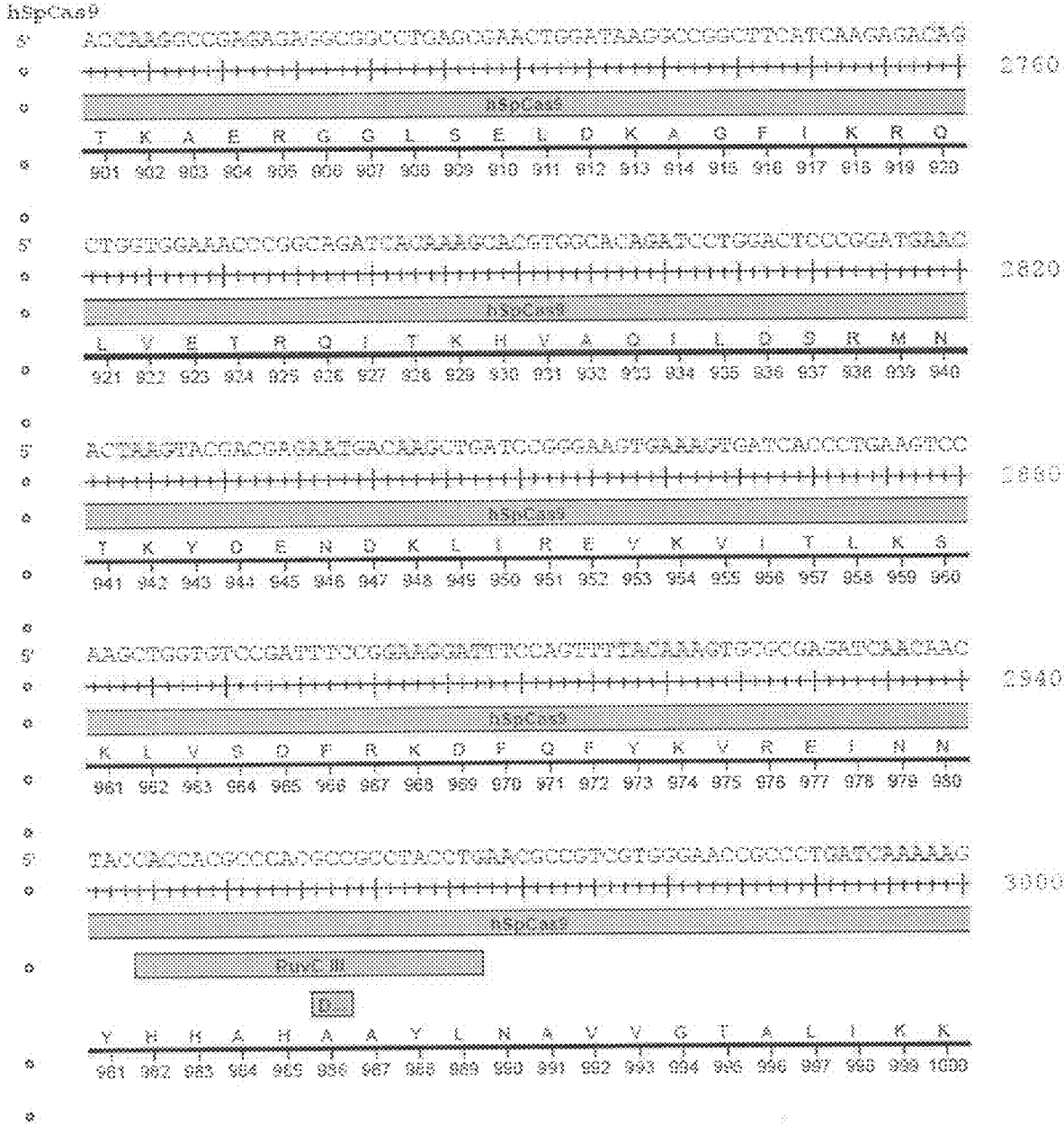

FIG. 411

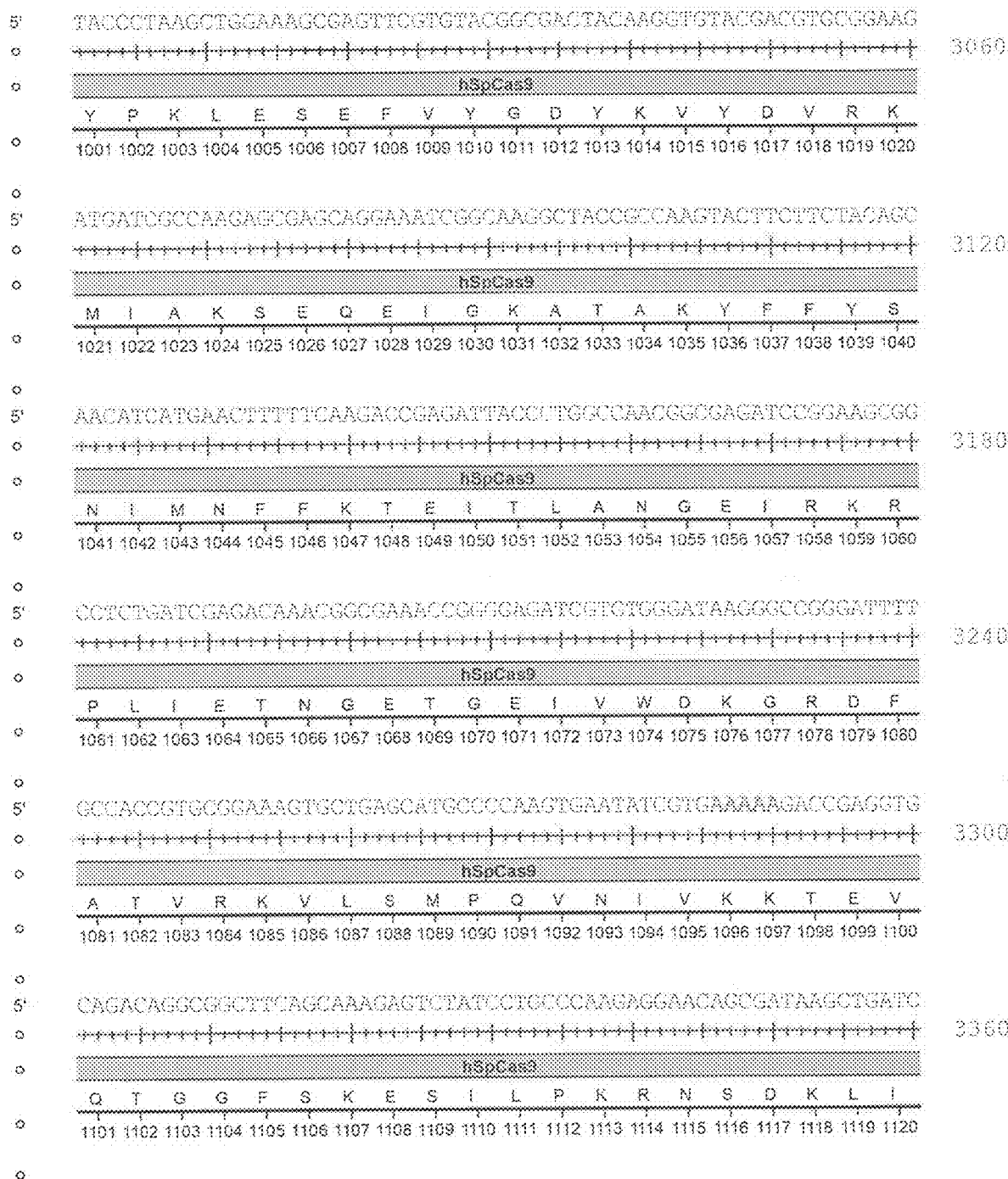

FIG. 41J

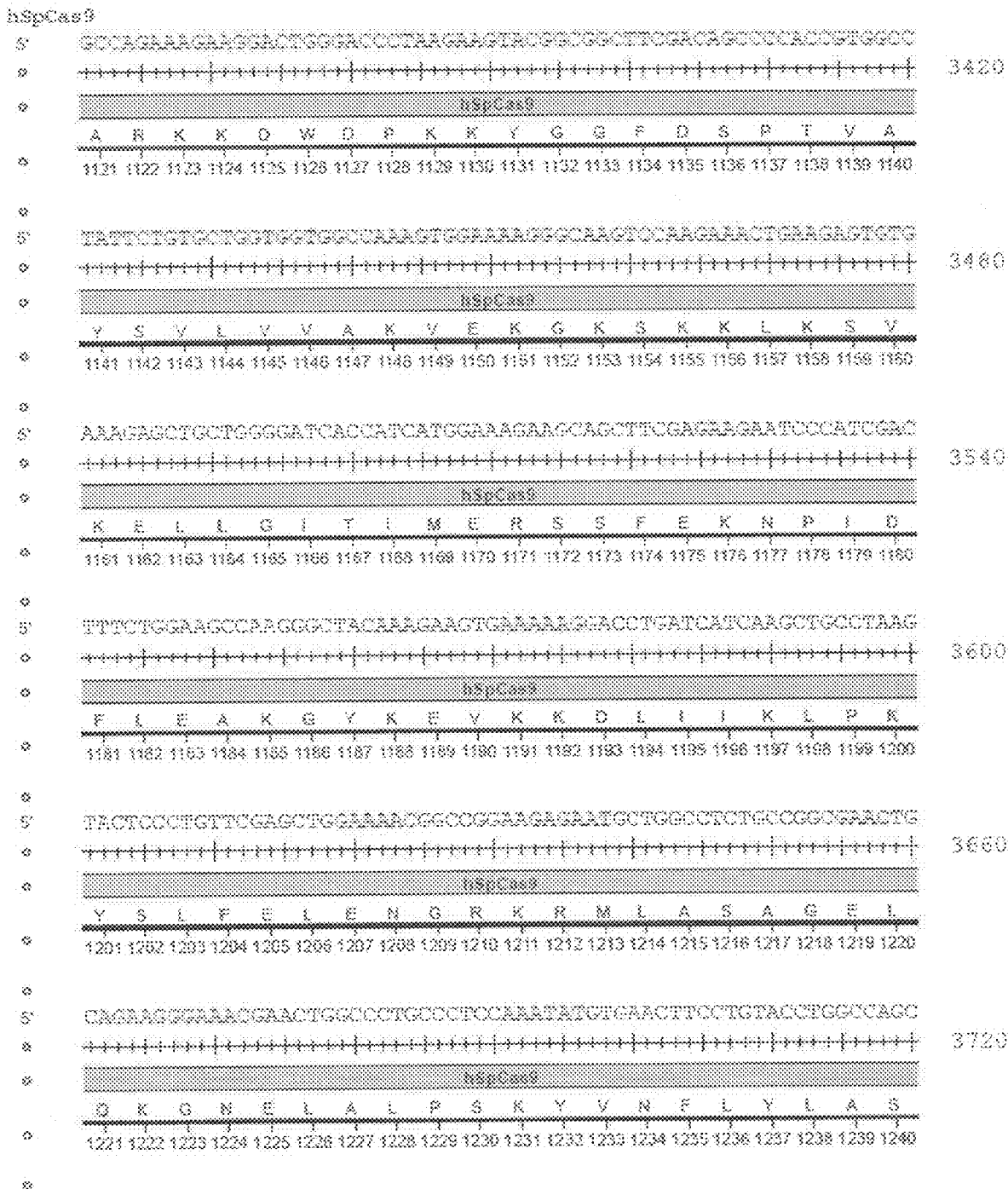

FIG. 41K

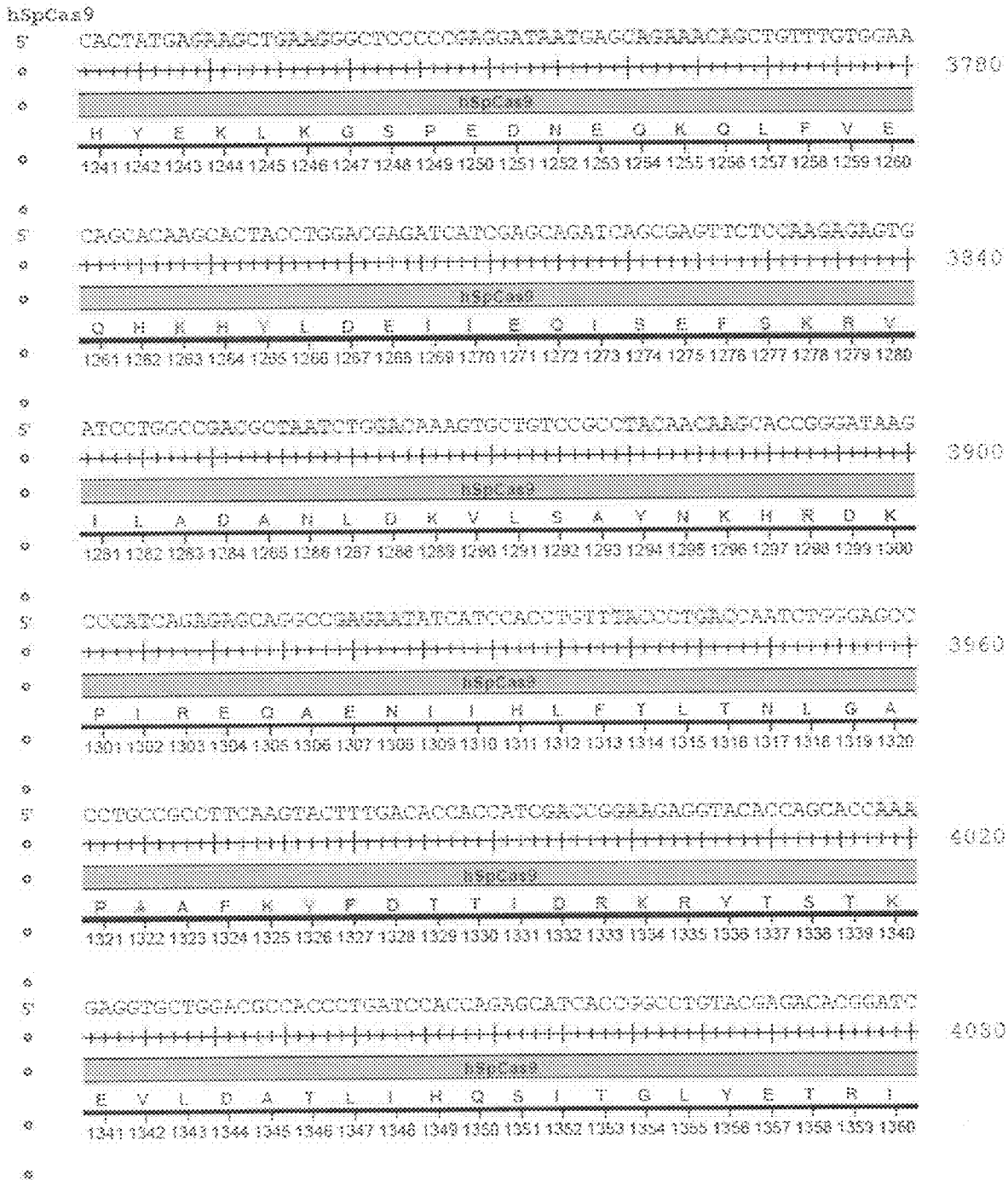

FIG. 41L

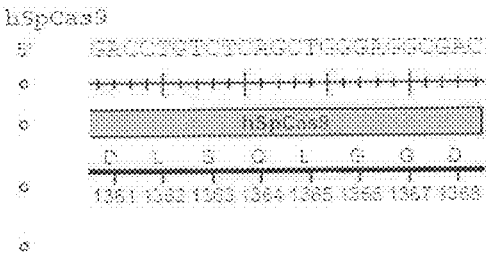

FIG. 41M

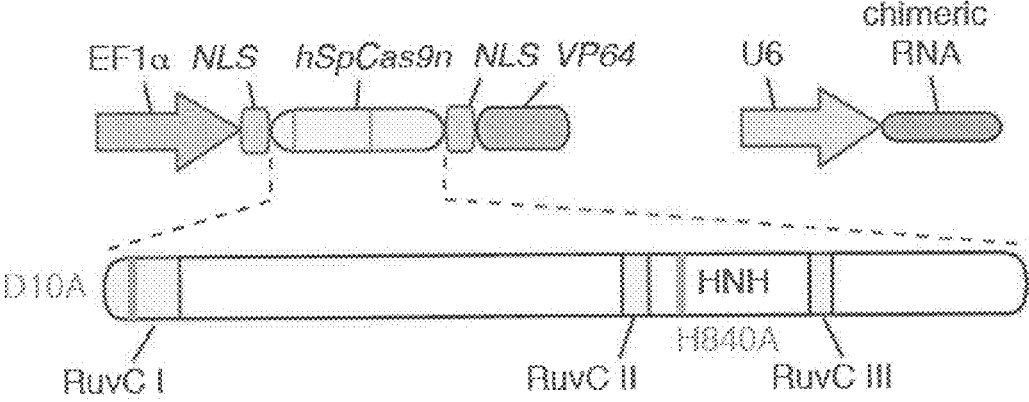

FIG. 42

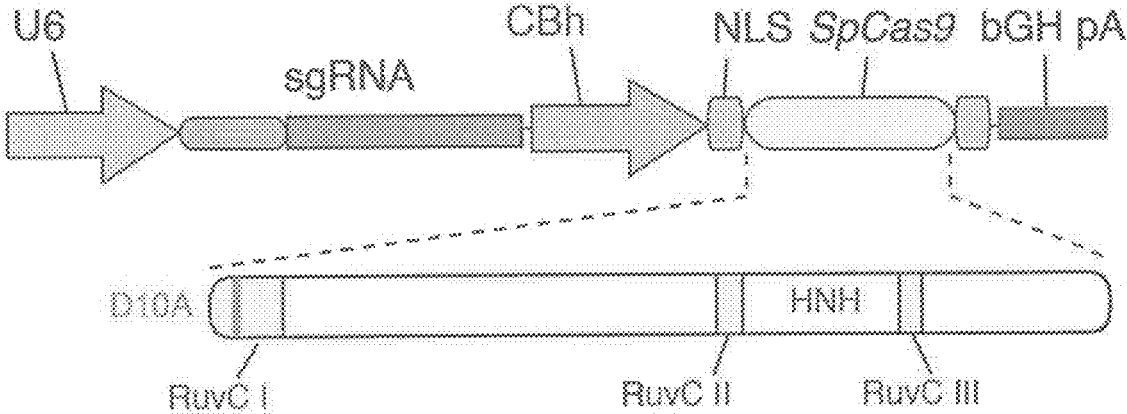

FIG. 43A

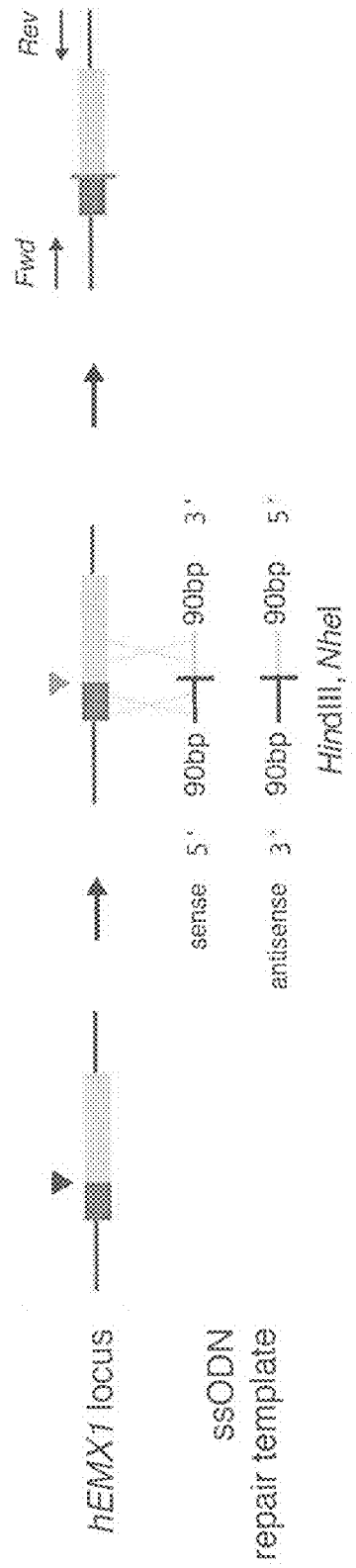

FIG. 43B

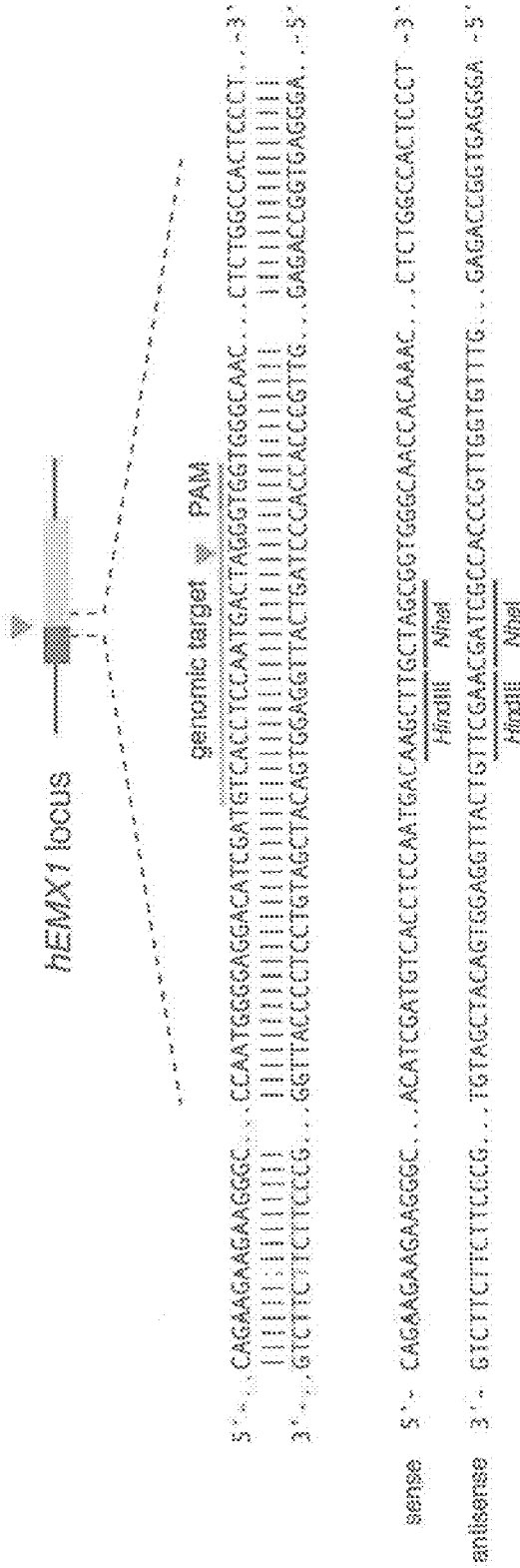

FIG. 43C

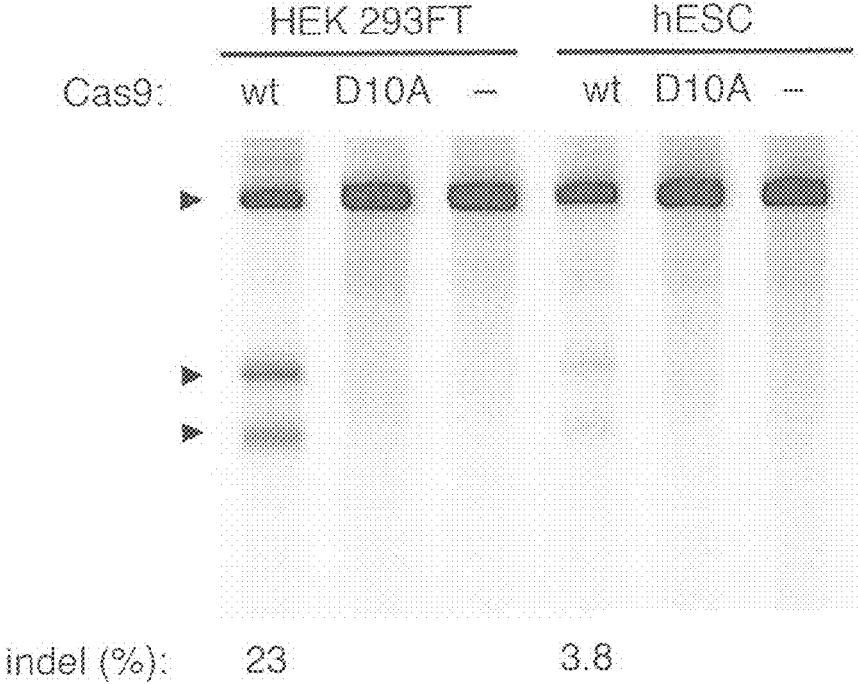

FIG. 43D

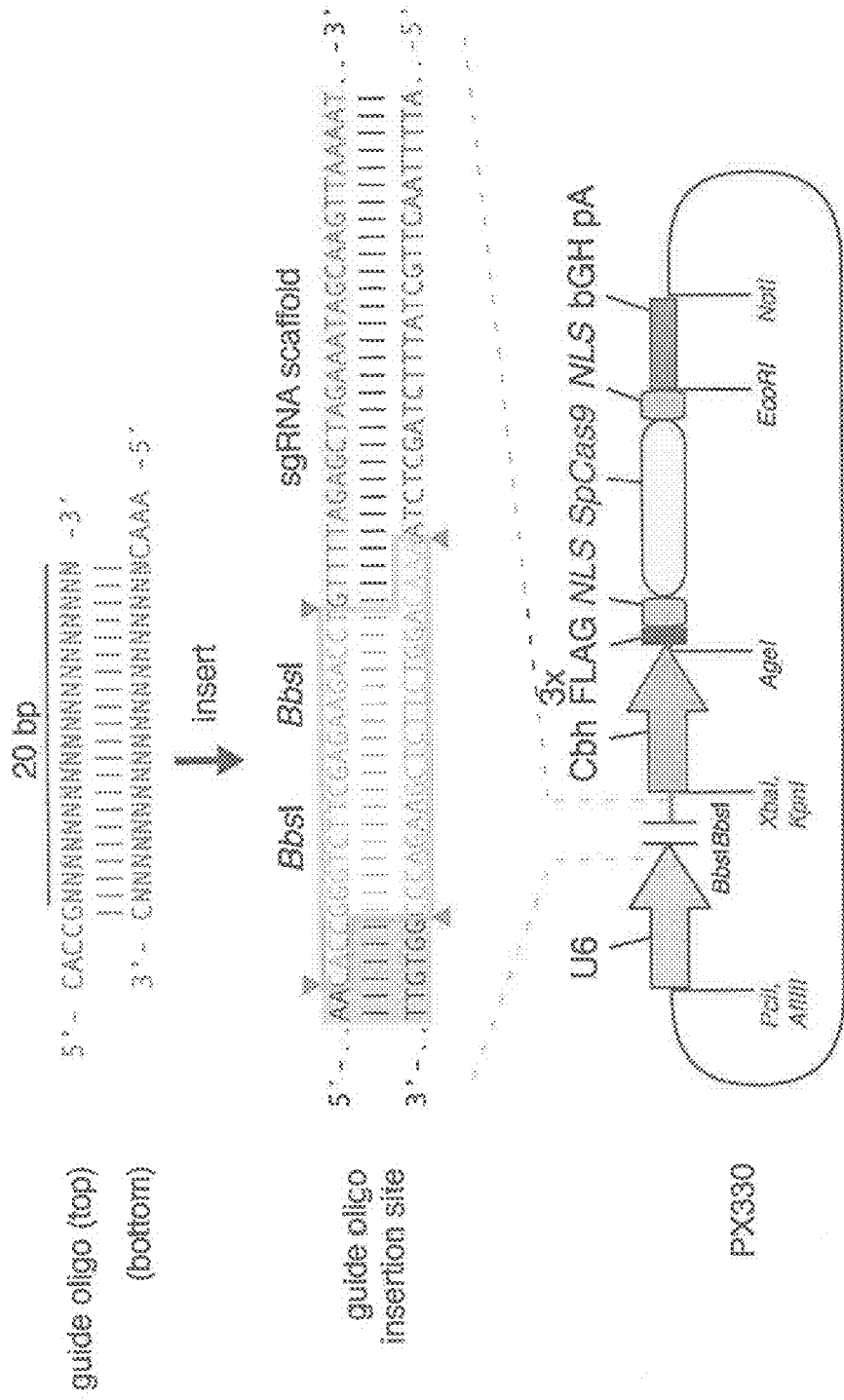

FIG. 44A

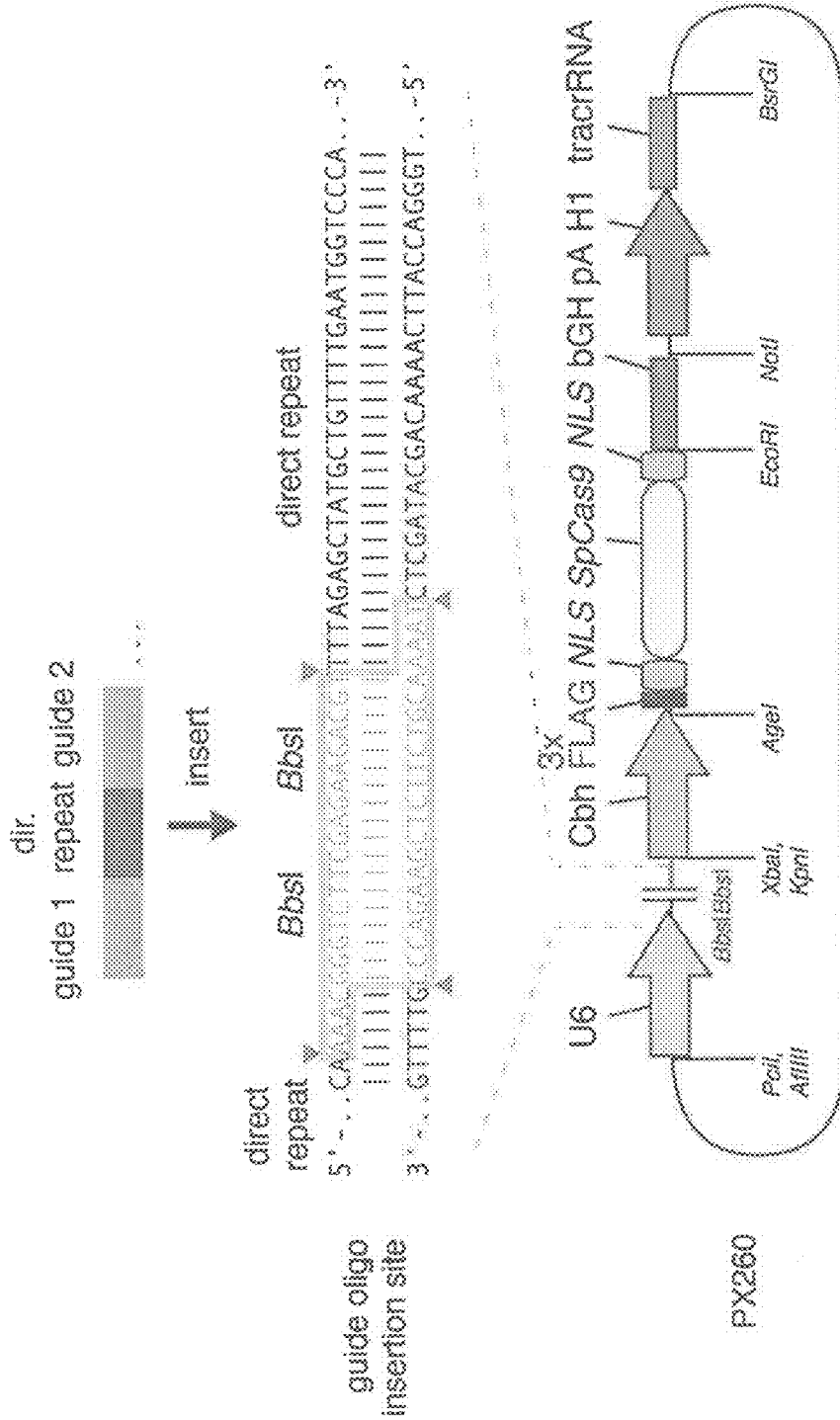

FIG. 44B

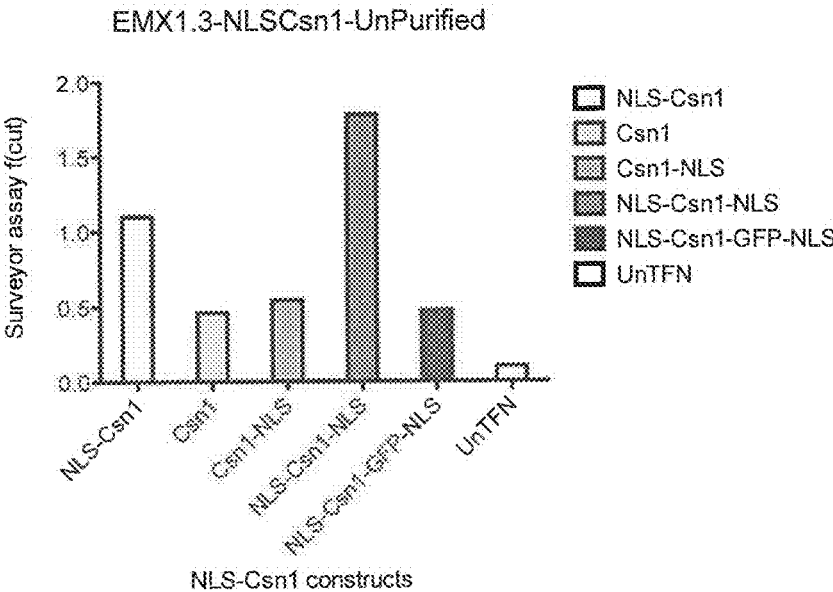

FIG. 45

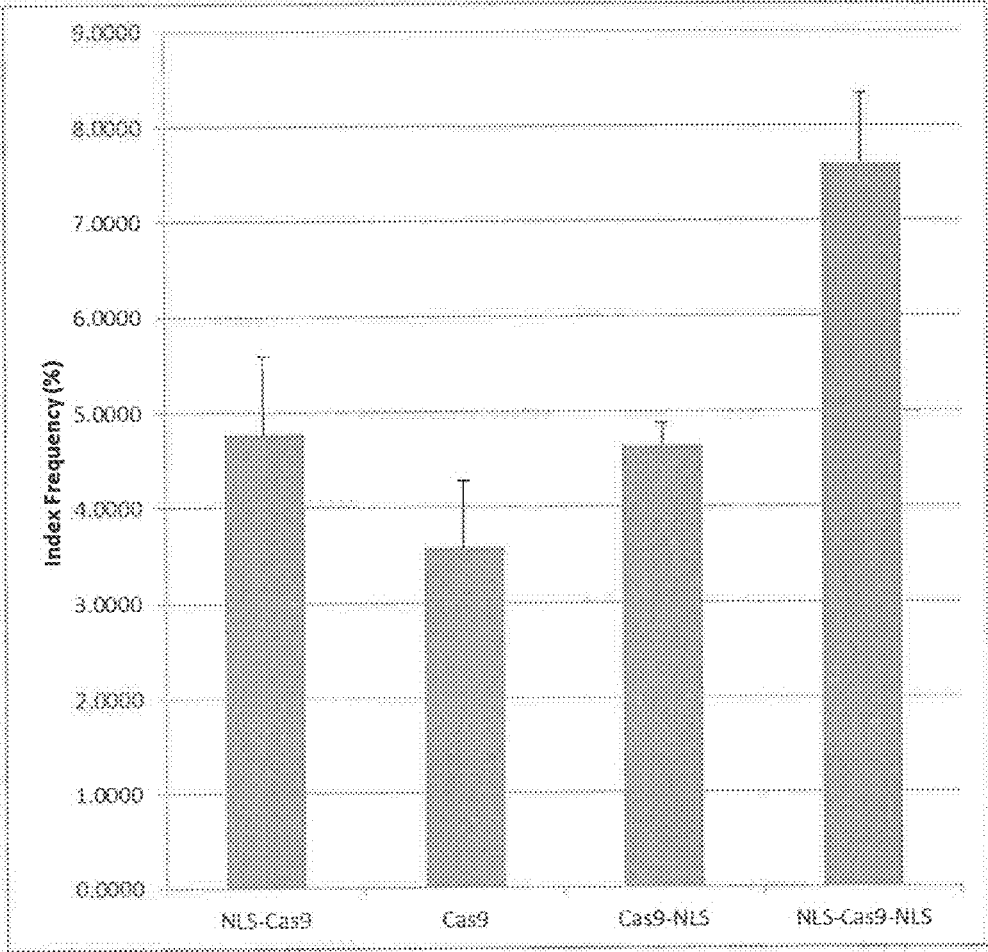

FIG. 46

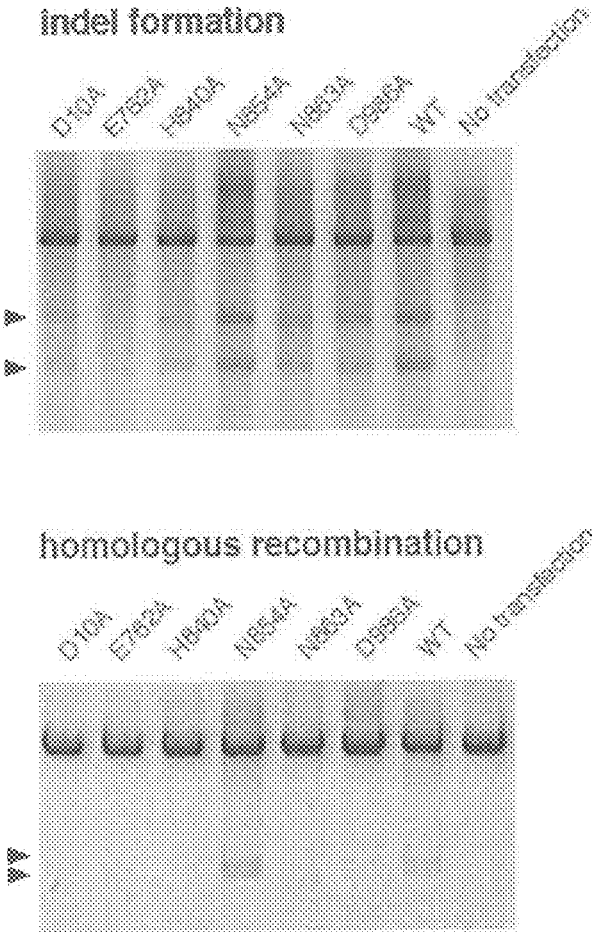

FIG. 47

FIG. 48A

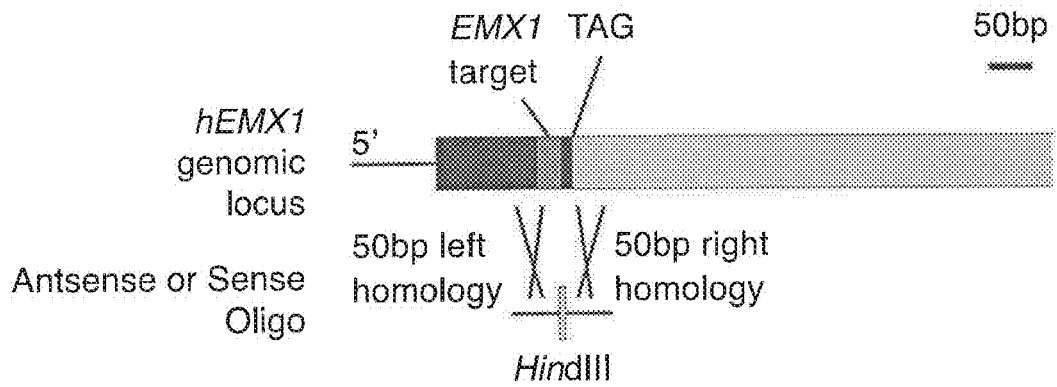
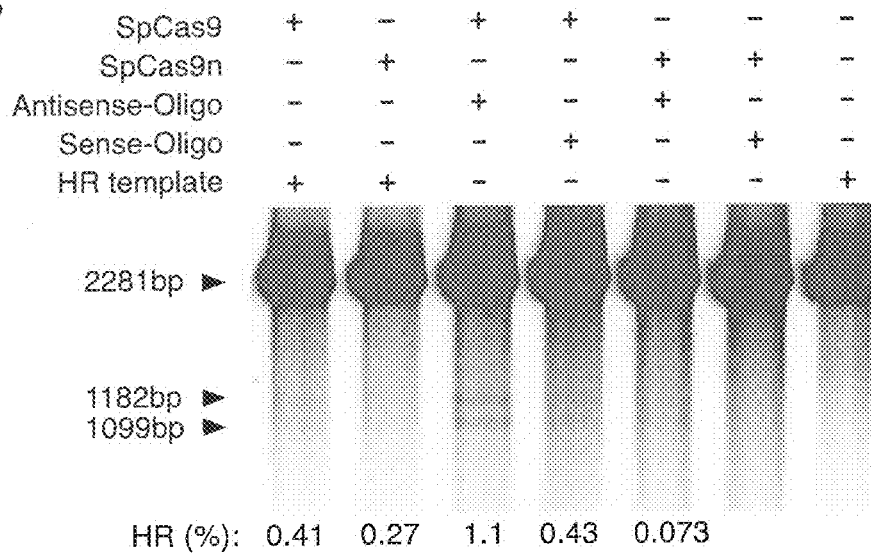

FIG. 48B



Conditional Cas9, Rosa26 targeting vector map

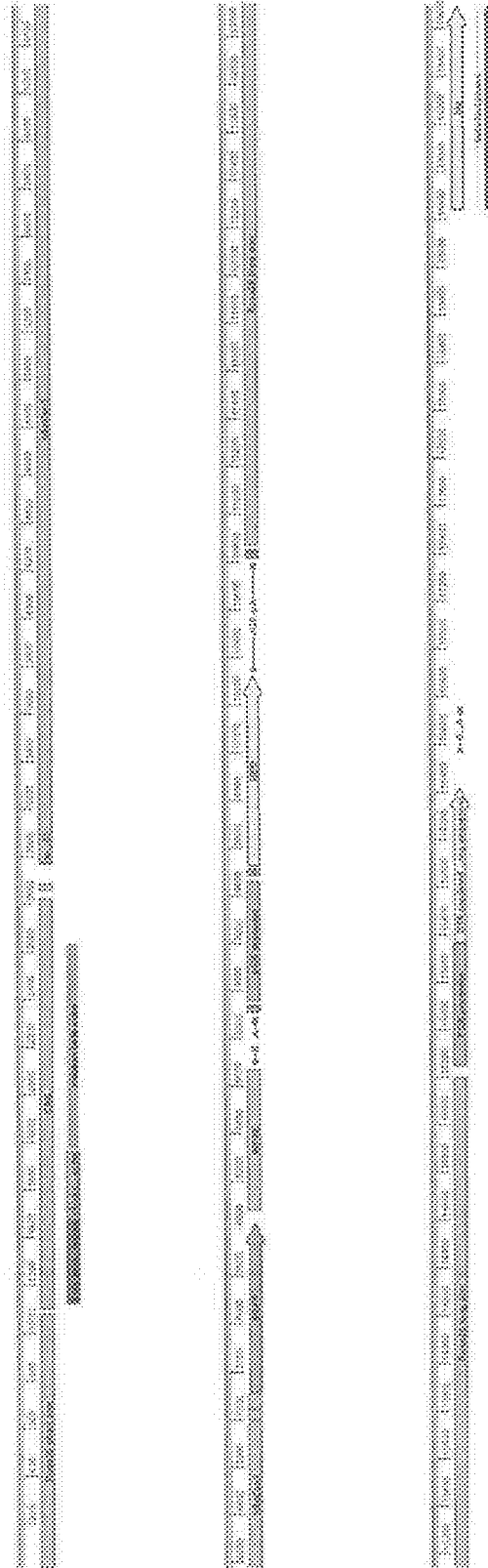

FIG. 49A

Constitutive Cas9, Rosa26 targeting vector map

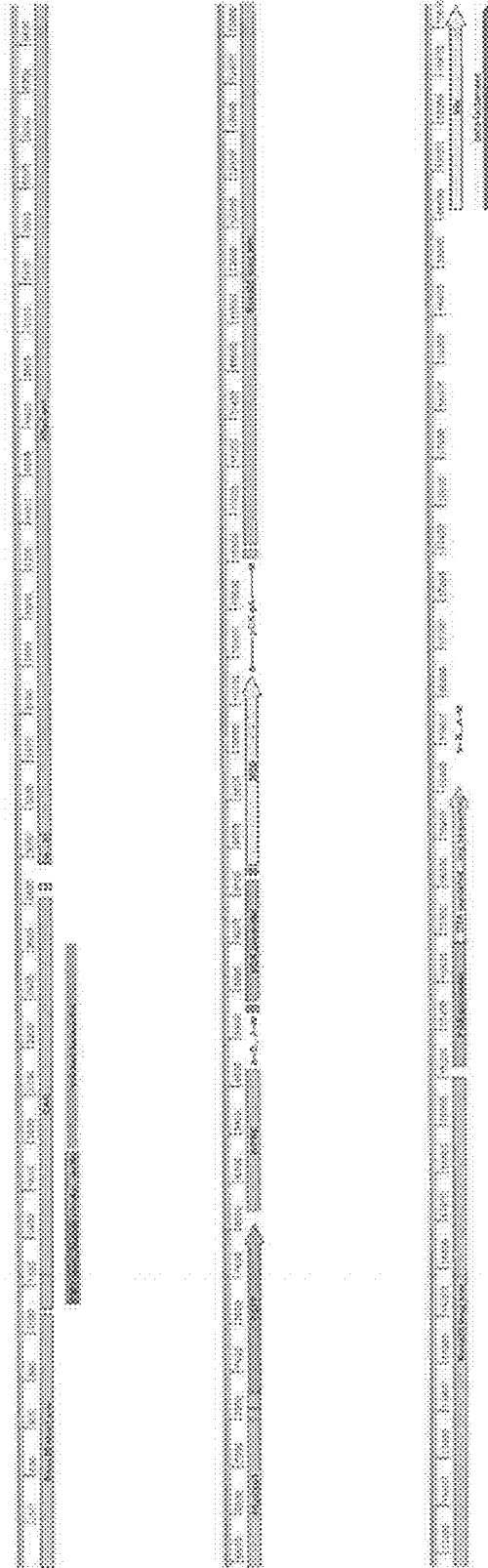

FIG. 49B

pCAG

ccgtttaaacaattctgcaggaatctagttattaatagtaataaatacggggcattagttcatagcccatataggagttccgcgttacataact
acggtaaatggcccgcctggctgaccgccaacgacccccgccattgacgtcaataatgacgtatgttccatagtaacgccaataggga
ctttccattgacgtcaatgggtggagtattacgggtaaacctcccacttggcagtacatcaagtgtatcatatgccaagtacgccccattgac
gtcaafgacggtaaatggcccgcctggcattatgccagtaacatgacctatgggactttctacttggcagtacatctacgtatgacatcgc
tattaccatggcagggtagccccacgttctgcttcaactctccccatctccccccctcccccccccaattttgtattttatittttaattttt
gtgcagcgatgggggcggggggggggggggggggggggcggcggccaggcggggcggggcggggcggaggggcggggcggggcggaggc
ggagaggtgcggcggcagccaatcagagcggcggcggcgtccgaaagtttctttatggcggaggcggcggcggcggcggccctataaaaa
gcgaagcggcggcggggggaAGTCGCTGCGcgctgcttgccttgccttgccttgccttgccttgccttgccttgccttgccttgccttgc
ccggtctgactgaccgcttactcccacaggtgagcgggggggacggcccttctctcgggctgtaattagcgttggtttaatagacggc
ttgtttttttctgtggctgctgaaagccttgggggctccgggaggggcccttggcgggggggagcggctcgggggggtgcgtgcgtgtg
gtgtgcgtggggagcggcggcgtgcggctccggcgtgcccggcggcgtgtgagcgtgcggggcggcggcggggcgttggcgtccgc
agtgtgcgcgaggggagcggcggcggggggggtgccccggggtgcggggggggcgtgcgaggggaacaagggtgcgtgcgggggt
gtgtgcgtgggggggtgagcaggggggtgaggcggcgtggcggcggcggcggcggcggcggcggcggcggcggcggcggcggcggcggc
gcccggcttgggggtgcggggctccgtacggggcgtggcggcggggcctgcctgcccggcgggggggtggcggcaggtgggggtgc
ggggcggggcggggc
cggcgagcgcagccattgctttatggtaactgtgcgagaggggcaggggaacttctttgtcccaaatctgtgaggagccgaaatctgg
gagggc
ggcgtgcgcggc
cgggggttcggcttctggcgtgtgaccggggctctagagcctctgctaaaccatgtcatgcttctcttttctacagctcctgggcaactg
ctggttattgtgtctcatatitggcaaa

NLS-Cas9-NLS

ATGGACTATAAGGACCACGACGGAGACTACAAGGATCATGATATTGATTACAAAGA
CGATGACGATAAGATGGCCCCAAAGAAGAAGCGGAAGGTTCGGTATCCACGGAGTCC
CAGCAGCCGACAAGAAGTACAGCATCGGCCTGGACATCGGCACCAACTCTGTGGGC
TGGGCCGTGATCACCGACGAGTACAAGGTGCCAGCAAGAAATTCAAGGTGCTGGG
CAACACCGACCGGCACAGCATCAAGAAGAACCTGATCGGAGCCCTGCTGTTGACA
GCGGCGAAACAGCCGAGGCCACCCGGCTGAAGAGAACCGCCAGAAGAAGATACAC
CAGACCGAAGAACCGGATCTGCTATCTGCAAGAGATCTTCAGCAACGAGATGGCCA
AGGTGGACGACAGCTTCTTCCACAGACTGGAAGAGTCTTCTGCTGGTGAAGAGGAT
AAGAAGCACGAGCGGCACCCCATCTTCGGCAACATCGTGGACGAGGTGGCCTACCA
CGAGAAGTACCCACCATCTACCACCTGAGAAAGAACTGGTGGACAGCACCGACA
AGGCCGACCTGCGGCTGATCTATCTGGCCCTGGCCCACATGATCAAGTTCCGGGGCC
ACTTCTGATCGAGGGCGACCTGAACCCCGACAACAGCGACGTGGACAAGCTGTTC

FIG. 50A

ATCCAGCTGGTGCAGACCTACAACCAGCTGTTGAGGAAAACCCCATCAACGCCAG
CGGCGTGGACGCCAAGGCCATCCTGTCTGCCAGACTGAGCAAGAGCAGACGGCTGG
AAAATCTGATCGCCCAGCTGCCCGGCGAGAAGAAGAATGGCCTGTTCCGgAACCTG
ATTGCCCTGAGCCTGGGCCTGACCCCCAACTTCAAGAGCAACTTCGACCTGGCCGAG
GATGCCAAACTGCAGCTGAGCAAGGACACCTACGACGACGACCTGGACAACCTGCT
GGCCAGATCGGCGACCAGTACGCCGACCTGTTTCTGGCCGCCAAGAACCTGTCCG
ACGCCATCCTGCTGAGCGACATCCTGAGAGTGAACACCGAGATCACCAAGGCCCCC
CTGAGCGCCTCTATGATCAAGAGATACGACGAGCACCACCAGGACCTGACCCTGCT
GAAAGCTCTCGTGC GG CAGCAGCTGCCTGAGAAGTACAAAGAGATTTTCTTCGACC
AGAGCAAGAACGGCTACGCCGGCTACATTGACGGCGGAGCCAGCCAGGAAGAGTTC
TACAAGTTCATCAAGCCCATCCTGGAAAAGATGGACGGCACCGAGGAACTGCTCGT
GAAGCTGAACAGAGAGGACCTGCTGCGGAAGCAGCGGACCTTCGACAACGGCAGC
ATCCCCACCAGATCCACCTGGGAGAGCTGCACGCCATTCTGCGGCGGCAGGAAGA
TTTTTACCCATTCTGAAGGACAACCGGGAAAAGATCGAGAAGATCCTGACCTTCCG
CATCCCCTACTACGTGGGCCCCTCTGGCCAGGGGAAAACAGCAGATTTCGCTGGATGA
CCAGAAAGAGCGAGGAAACCATCACCCCTGGAACCTTCGAGGAAGTGGTGGACAA
GGGCGCTTCCGCCCAGAGCTTCATCGAGCGGATGACCAACTTCGATAAGAACCTGC
CCAACGAGAAGGTGCTGCCAAGCACAGCCTGCTGTACGAGTACTTCACCGTGTAT
AACGAGCTGACCAAAGTGAAATACGTGACCGAGGGAATGAGAAAGCCCCGCCTTCCT
GAGCGGCGAGCAGAAAAAGGCCATCGTGGACCTGCTGTTCAAGACCAACCGGAAA
GTGACCGTGAAGCAGCTGAAAGAGGACTACTTCAAGAAAATCGAGTGCTTCGACTC
CGTGGAATCTCCGGCGTGGAAGATCGGTTCAACGCCTCCCTGGGCACATACCACG
ATCTGCTGAAAATTATCAAGGACAAGGACTTCCTGGACAATGAGGAAAACGAGGAC
ATTCTGGAAGATATCGTGCTGACCCTGACACTGTTTGAGGACAGAGAGATGATCGA
GGAACGGCTGAAAACCTATGCCACCTGTTTCGACGACAAAGTGATGAAGCAGCTGA
AGCGGCGGAGATACACCGGCTGGGGCAGGCTGAGCCGGAAGCTGATCAACGGCATC
CGGGACAAGCAGTCCGGCAAGACAATCCTGGATTTCTGAAGTCCGACGGCTTCGC
CAACAGAACTTCATGCAGCTGATCCACGACGACAGCCTGACCTTTAAAGAGGACA
TCCAGAAAGCCCAGGTGTCCGGCCAGGGCGATAGCCTGCACGAGCACATTGCCAAT
CTGGCCGGCAGCCCCGCCATTAAGAAGGGCATCCTGCAGACAGTGAAGGTGGTGA
CGAGCTCGTGAAAGTGATGGGCCGGCACAAGCCCAGAACATCGTGATCGAAATGG
CCAGAGAGAACCAGACCACCCAGAAGGGACAGAAGAACAGCCGCGAGAGAATGAA
GCGGATCGAAGAGGGCATCAAAGAGCTGGGCAGCCAGATCCTGAAAGAACACCCC
GTGGAAAACACCCAGCTGCAGAACGAGAAGCTGTACCTGTACTACCTGCAGAATGG
GCGGGATATGTACGTGGACCAGGAACTGGACATCAACCGGCTGTCCGACTACGAT

FIG. 50B

GTGGACCATATCGTGCCTCAGAGCTTTCTGAAGGACGACTCCATCGACAACAAGGTG
CTGACCAGAAGCGACAAGAACCAGGGGCAAGAGCGACAACGTGCCCTCCGAAGAGG
TCGTGAAGAAGATGAAGAATACTGGCGGCAGCTGCTGAACGCCAAGCTGATTACC
CAGAGAAAGTTCGACAATCTGACCAAGGCCGAGAGAGGGCGCCTGAGCGAACTGG
ATAAGGCCCGCTTCATCAAGAGACAGCTGGTGGAAACCCGGCAGATCACAAAGCAC
GTGGCACAGATCCTGGACTCCCGGATGAACTAAGTACGACGAGAATGACAAGCT
GATCCGGGAAGTGAAAGTGATCACCTGAAGTCCAAGCTGGTGTCCGATTTCCGGA
AGGATTTCCAGTTTACAAAGTGCGCGAGATCAACAATACTACCACCAGCCCACGAC
GCCTACCTGAACGCCGTCGTGGGAACCCGCCCTGATCAAAAAGTACCCTAAGCTGGA
AAGCGAGTTCGTGTACGGCGACTACAAGGTGTACGACGTGCGGAAGATGATCGCCA
AGAGCGAGCAGGAAATCGGCAAGGCTACCGCCAAGTACTTCTTCTACAGCAACATC
ATGAACTTTTTCAAGACCGAGATTACCCTGGCCAACGGCGAGATCCGGAAGCGGCC
TCTGATCGAGACAAACGGCGAAACCCGGGAGATCGTGTGGGATAAGGGCCGGGATT
TTGCCACCGTGCAGAAAGTGCTGAGCATGCCCAAGTGAATATCGTGAAAAAGACC
GAGGTGCAGACAGGCGGCTTCAGCAAAGAGTCTATCCTGCCCAAGAGGAACAGCGA
TAAGCTGATCGCCAGAAAGAAGGACTGGGACCCTAAGAAGTACGGCGGCTTCGACA
GCCCCACCGTGGCCTATTCTGTGCTGGTGGTGGCCAAAGTGGAAAAGGGCAAGTCC
AAGAACTGAAGAGTGTGAAAGAGCTGCTGGGGATCACCATCATGGAAAGAAGCA
GCTTCGAGAAGAATCCCATCGACTTTCTGGAAGCCAAGGGCTACAAAGAAGTGAAA
AAGGACCTGATCATCAAGCTGCCTAAGTACTCCCTGTTTCGAGCTGGAAAACGGCCG
GAAGAGAATGCTGGCCTCTGCCGGCGAAGTGCAGAAGGGAAACGAAGTGGCCCTGC
CCTCCAAATATGTGAACTTCTGTACCTGGCCAGCCACTATGAGAAGCTGAAGGGCT
CCCCGAGGATAATGAGCAGAAACAGCTGTTTGTGGAACAGCACAAGCACTACCTG
GACGAGATCATCGAGCAGATCAGCGAGTTCTCCAAGAGAGTGATCCTGGCCGACGC
TAATCTGGACAAAGTGCTGTCCGCCTACAACAAGCACCCGGGATAAGCCCATCAGAG
AGCAGGCCGAGAAATATCATCCACCTGTTTACCCTGACCAATCTGGGAGCCCCTGCCG
CCTTCAAGTACTTTGACACCACCATCGACCGGAAGAGGTACACCAGCACCAAGAG
GTGCTGGACGCCACCCTGATCCACCAGAGCATCACCGGCCTGTACGAGACACGGAT
CGACCTGTCTCAGCTGGGAGGCGACAAAAGGCCGGCGGCCACGAAAAAGGCCGGC
CAGGCAAAAAAGAAAAAG

P2A-EGFP

ggaagcggagccaacttctccctgttgaacaagcaggggatgtcgaagagaatccgggccaGTGAGCAAGGGCGA
GGAGCTGTTACCGGGGTGGTGGCCATCCTGGTTCGAGCTGGACGGCGACGTAAACG
GCCACAAGTTCAGCGTGTCCGGCGAGGGCGAGGGCGATGCCACCTACGGCAAGCTG
ACCCTGAAGTTCATCT

FIG. 50C

GCACCACCGGCAAGCTGCCCGTGCCCTGGCCCACCCTCGTGACCACCCTGACCTACG
 CGGTGCAGTGCTTCAGCCGCTACCCCGACCACATGAAGCAGCACGACTTCTTCAAGT
 CCGCCATGCCCGAAGGCTACGTCCAGGAGCGCACCATCTTCTTCAAGGACGACGGC
 AACTACAAGACCCGCGCCGAGGTGAAGTTCGAGGGCGACACCCTGGTGAACCGCAT
 CGAGCTGAAGGGCATCGACTTCAAGGAGGACGGCAACATCCTGGGGCACAAGCTGG
 AGTACAATAACAACAGCCACAACGTCTATATCATGGCCGACAAGCAGAAGAACGGC
 ATCAAGGTGAACTTCAAGATCCGCCACAACATCGAGGACGGCAGCGTGCAGCTCGC
 CGACCACTACCAGCAGAACACCCCCATCGGCGACGGCCCCGTGCTGCTGCCCGACA
 ACCACTACCTGAGCACCCAGTCCGCCCTGAGCAAAGACCCCAACGAGAAGCGCGAT
 CACATGGTCTGCTGGAGTTCGTGACCGCCGCGGGGATCACTCTCGGCATGGACGAG
 CTGTACAAG

WPRES

Cgataatcaacctctggattacaaaattgtgaaagattgactggattcctaactatgttgccttitaagctatgtgatacgtcttfaatgc
 cttgtatcatgctatgtcccgatggtttcatttctcctctgtatnaatcctggttctctctttatgaggagttgtggccggttgcagg
 caacgtggtgtgtgcaactgtggttctgacgcaacccccactggttggggcattgccaaccctgtcagctccttccgggactttctgtt
 tccccctccctattgccacggcggaactcatcgcccgctgcttgcctgcctggcgctgtggacaggggtcgggtgttgggcaactgacaattcgtg
 gtgtgtggggaatcatgctcttctgtgctgcctgtgttggcactgattctgcgaggacgtctctgtctacgtcccttggc
 cctcaatccagcggaccttcccgcggtcgtgcgggctctgcggcctctccgcgtcttccgcttccgcttccctccagacagtgaggatctc
 ctttggcgccctcccgcatg

bGHpolyA

cgacCTCGACtgtgceftctagtgccagcaatctgttggcttccccctcccctgcttcttaccctggaagggtgccactcccactgt
 ccttccataataaaatgaggaaatgcatcgcattgtctgagttaggtcattctattctgggggggtgggtggggcaggacagcaaggggg
 aggattgggaagacaatGgcagggcatg

loxP-SV40polyAx3-loxP

ataactfcgtataatgtatgctatcgaagttattcgcgatgaataaaatgaaagcftgcagatctgogactctagaggatctgcgactctagagg
 atcataatcagccntaccacatttttagaggtttactngcttataaaaaactcccacacctcccctgaaactgaaacataaaaatgaatgcaa
 ttgtgttggtaactgtttattgcaactfataatggttacaaaataagcaatgcatcacaaaattcacaataaagcatttttcaactgcaactctagt
 tgtggtttgtccaaactcatcaatgtatcttatcatgctggatctgcgactctagaggatcataatcagccataccacatttttagaggtttactt
 gcttataaaaaactcccacacctcccctgaaactgaaacataaaaatgaatgcaattgttggtaactgtttattgcaactfataatggttaca
 aataaagcaatagcatcacaaaattcacaataaagcatttttcaactgcaactctagtgtgttggtaactgtttattgcaactfataatgtatct
 ggatctgcgactctagaggatcataatcagccataccacatttttagaggtttacttgccttataaaaaactcccacacctcccctgaaactga
 aacataaaaatgaatgcaattgttggtaactgtttattgcaactfataatggttacaata

FIG. 50D

aagcaatagcatcacaaattcacaaataaagcattttttactgcattctagtgtgggttgcacaaactcatcaatgtatcttatcatgtctggat
ccccatcaagctgatccggaaccctaataataacttcgtataatgtatctatacgaagttat

Rosa26 short homology arm

caggccctccgagcgtggtggagccggttctgtgagacagccgggtacgagctctgacgctggaaggggcaagcgggtggtgggagg
aatgccgtccgcctgcagcaaccggagggggaggagagaagggagcggaaaagtctccaccggacgcccattggctcggggggg
ggggggcagcggagggaGcgcctccggccgagctctcgtcgtctgattggcttCttttcctcccggcgtgtgtgaaaacacaatggcgtgt
ttggttggcgttaaggcgcctgtcagttaacggcagccggagtgccgagccgccggcagcctcgctctgccactgggtggggcgggag
gtaggtggggtgaggcgagctgGacgtgcgggcccggctggcctctggcggggcggggggaggggagggtcagcgaagt
gctcgogcgcgagcggcccccaccctcccctctctggggagctgtttaccgcccggcggcggcctcgtcgtctgattggctctc
ggggcccagaaaactggcccttgcattggctctgttctgtcaagtgagtgccacccggcccaggcggggggcggcaggagggcctc
ccaggttccggcctcccctcggccccgcgcgcagagctctggccgcggcctctgcgcaacgtggcaggaagcgcgcctggggggc
ggggacgggagtagggcgtgagcggcgtgaggggggggtcaagcacgttccgacttgagtgtcctcaagagggcggcgtgctgagccag
acctccatcggcactccggggagtgagggaaggagcggagggctcagttgggctgtttggaggcaggaagcactgctctcccaaatg
cgctctgagttgtatcagtaaggagctgagtgaggtaggcgggagaaagggccacccctctccggaggggggaggggaggtgtgc
aatactttctgggagttctctgctctccctggcttctgaggacccctcgggctgggagaatccctcccctcttccctctgctgactgcaa
ctccagttcttag

Rosa26 long homology arm

agatgggcgggagctcttctgggagcctfcaaaggctaacctgggtgtgtggcctgtctcagggggaattgaacaggtgtaaaatggag
ggacaagactcccacagattfctgtgtgctgggaagtittitaataggggcaataaggaatgggggagtaggtatcctctgggggttt
atgcagcaaaaactacagggtattatgctgtgatcccgcccgagiatfctcctcagggttagattaagacatgctcaccgagtttatactct
cctgttGAGATCCTTACTACAGTATGAAATTACAGTGTTCGCGAGTTAGACTATGTAAGC
AGAATTTTAAATCATttttaaagagcccagtaactcatatccattctccgctctctgacgcttatcaaaaggtaTtttgaaca
ctcatttagccccatttcaattatfatactggccttatacaccctagacagagcaattggcattttcccttctctgatcttagaagtctgatgactca
tgaaccagacagattagttacatacaccacaaatcaggcctgtagctggggocctaacactgcagttctttataactccttagtacacttttg
ttgatcctttgcctgacctaatttcaagtgctcatalcactctccctcagggctgtgctcaccattgggcctattctcagtcacggggtttaca
acaatagatgtattgagaatccaaactaaagccttaacttccactcccataagcctctctcttttctcctattTATAAACTGAGCT
ATTAACCATTAATGGTTTCCAGGTGGATGTCTCCTCCCCAATATTACCTGATGTATC
TTACATATTGCCAGGCTGATATTTTAAGACATTAAGGATATTTTCATTATTGAGCC
ACATGGTATTGATTA CTGCTtactaaaattttgcaattgtacacatctgtaaagggtggctcttttggaaatgaaaggtcaggt
gtttgttcttctgacciaaggcttctgagcctgattttttctatfcaagcagtgcttctctggactggctgactcatggcattctacagtta
ttgctgttctaaatgtgattttgccaagctcttcaggacctafaaattttgcttgactgtagccaaacacaagtaaatgattaagcaacaatgt
atgtggaagcttggttttaggtgtgtgtgtgtgtgtgtgtctctataataaactatccaggggctggagagggtggctggagttcaagag
cacagactgctctccagaagtc

FIG. 50E

ctgagttcaattccagcaaccacatgggtggctcacaaccatctgtaatgggatctgatgccctctctgggtgtgtgaagaccacaagtgtat
tcacafaaataaataaaTCCTCCTTCTTCTTCTTTTTTTTTTTTTTAAAGAGAATACTGTCTCCAG
TAGAAiTTACTGAAGTAATGAAATACTTTGTGTTTGTTCCAATATGGTAGCCAATAAT
CAAATiACTCTTTaAGCACTGGAAATGTtACCAAGGAACTAaTTTTtATTTgAAGTGTaA
CTGTGGACAGAGGAGCCATAACTGCAGACTTGTGGGATACAGAAGACCAATGCAGA
CiTTAATGTCTTTTTCTCTTACACTAAGCAATAAAGAAAATAAAAATTGAACTTCTAGTA
TCCTATTTGTTiAAACTGCTAGCTTTACiTAACTTTTTGTGCTTCATCTATACAAAGCTG
AAAGCTAAGTCTGCAGCCATTACTAAACATGAAAGCAAGTAATGATAATTTTGGATT
TCAAAAATGTAGGGCCAGAGTTTAGCCAGCCAGTGGTGGTGGCTTGCCTTTATGCCiTT
AATCCCAGCACTCTGGAGGCAGAGACAGGCAGATCTCTGAGTTTGGAGCCAGCCTG
GiCTACACATCAAGTTCTATCTAGGATAGCCAGGAATACACACAGAAACCCTGTTGG
GGAGGGGGGCTCTGAGATTTCAATAAAATTATAATTGAAGCATTCCCTAATGAGCCAC
TATGGATGTGGCTAAATCCGTCTACCTTTCTGATGAGATTTGGGTATTATTTTTTCTG
TCTCTGCTGTIGGTTGGGTCITTTGACACTGTGGGCTTTCTTtAAAGCCTCCTTCTGC
CATGTGGTCTCTTGTTTGCTACTAACTTCCCATGGCTTAAATGGCATGGCTTTTTGCC
TTCTAAGGGCAGCTGCTGAGATTTGCAGCCTGATTTCCAGGGTGGGGTTGGGAAATC
TTTCAAACACTAAAATTGTCCITTAAtTTTTTTTTTAAAAAATGGGTTATATAATAAA
CCTCATAAAAATAGTTATGAGGAGTGAGGTGGACTAATATTAAaTGAGTCCCTCCCCT
ATAAAAGAGCTATTAAGGCTTTTTGTCTTATACTiAACTTTTTTTTTTAAATGTGGTATC
TTTAGAACCAAGGGTCTTAGAGTTTTAGTATACAGAACTGTTGCATCGCTTAATCA
GATTTTCTAGTTTCAAATCCAGAGAAATCCAAATTCCTTACAGCCAAAGTCAAATTA
GAATTTCTGACTTTiAATGTTAaTTTGCtTACTGTGAATATaAAAATGATAGCTTTTCCT
GAGGCAGGGTCTCACTATGTATCTCTGCCTGATCTGCAACAAGATATGTAGACTAAA
GTTCTGCCTGCTTTTTGTCTCCTGAATACTAAGGTTAAAATGTAGTAATACTTTTTGGAA
CTTGCAGGTCAGATTCTTTTATAGGGGACACACTAAGGGAGCTTGGGTGATAGTTGG
TAAAtgtgttaagtgatgaaaactgaattattatcacgcaacctacttttaaaaaaaaaagccaggcctgttagagcatgctTaaggg
atccctaggacttgcgagcacacaAGAGTAGiTACTTGGCAGGCTCCTGGTGAGAGCATAATTTCAA
AAAACAAGGCAGACAACCAAGAACTACAGTiAAGGTTACCTGTCTTTaAACCATCT
GCATATACACAGGGATATTAATAATTTCCAAATAATATTTTCAATCAAGTTTTCCCCC
ATCAAATTTGGGACATGGATTTCTCCGGTGAATAGGCAGAGTTGGAAACTAAACAAA
TGTTGGTTTTGTGATTTGTGAAATTGTTTTCAAGTGATAGTTAAAGCCCATGAGATAC
AGAACAAAGCTGCTATTTTCGAGGTCTCTTGGTTiATACTCAGAAGCACTTCTTTGGGT
TTCCCTGCACTATCCTGATCATGTGCTAGGCCTACCTTAGGCTGATTGTTGTTCAAAT
aAACTTAAGTTTCTGTGAGGTGATGTCATATGATTTTCATATATCAAGGCCAAAACATG
TTATATATGTTAAACATTTGTACTTAATGTGAAAGTTAGGTCTTTGTGGGT

FIG. 50F

TGATTTTtAAAtTTTCAAAAACCTGAGCTAAATAAGTCATTTTtACATGTCTTACATTTGGT
GgAATTGTATaATTGTGGTtTGCAGGCAAGACTCTCTGACCTAGTAACCCTaCCTATA
GAGCACTTTGCTGGGTcACAAGTCTAGGAGTCAAGCATTTCACCTTGAAGTTGAGAC
GTTTTGTAGTGTATACTAGTTtATATGTTGGAGGACATGTTTATCCAGAAGATATTC
AGGACTATTTTtGACTGGGCTAAGGAATTGATTCTGATTAGCACTGTTAGTGAGCAT
TGAGTGGCCTTTAGGCTTGAATTggagtcacitgtatatctcaataatgctggcctttttaaagccctgtctttatca
ccctgtttctacataatfttggtaaaagaactgttgggaTCTCCTTTTtGACAACAATAGCATGTTTTCAAG
CCATATTTTTTtTCCTTTTTTTTTTTTTTTGGTTTTTCGAGACAGGGTTTCTCTGTAT
AGCCCTGGCTGTCCCTGGAACtCACTTTGTAGACCAGGCTGGCCTCGAACTCAGAAAT
CCGCTGCTTCTGCCTCCTGAGTGC CGGGATTAAGGGCGTGCACCACCACGCCTGGC
TAAGTTGGATATTTTGTtATATAACTATAACCAATACTAACTCCACTGGGTGGATTTT
TAATTCAGTCAGTAGTCTTAAGTGGTCTTTATTGGCCCTTtATTAAAATCTACTGTTC
ACTCTAACAGAGGCTGTTGGtACTAGTGGCACHtAAGCAACTTCCTACGGATATACTA
GCAGAtAAGGGTCAGGGATAGAACTAGTCTAGCGTTTTGTATACCTACCAGCTtA
TACTACCTTGTTCtGATAGAAATATTTtAGGACATCTAGCTT

pPGK-Neo-pPGK-polyA
aatctaccgggtaggggagcgcctttcccaaggcagctctggagcatgoccttttagcagccccctggcacttggcgtacacaaagtgg
cctctggcctcgcacacattccacatccaccggtaggcgccaaaccggctccgttctttggaggccccctcgcgccacctctactcctccct
agtcagggaagttccccccgccccgagctcgcctcgtcaggacgtgacaaatggaagtagcacgtctcactagctcgtgcagatgga
cagcaccgctgagcaatggaagcgggtaggcccttggggcagcggccaatagcagctttgctcctcgtttctgggctcagaggctggg
aaggggtggggtccggggggcgggctcagggggcgggctcagggggcggggcggggcgccggaaggctcctcgggagcccgccattctgc
acgttcaaaagcgcagctcgcgcgctgctctcctcctcctcctcggcccttcgacctgcaatcgcctagcgaagtctctattctct
agaaagtataggaaacttccaccatgggatcggccaitgaacaagatggatgacagcaggtctcctccggccttgggtggagaggctat
tcggctatgactgggcacaacagacaatcggctcctctgatcccgccgttccggctgacagcagggggcggccgggtcttttgcag
accgacctgctcgggtccctgaatgaactgcaggacagggcagcggcctatcgtggctggccacgacggggcgttcttgcgcagctgt
gctcagctgtcactgaagcgggaagggactggctcctatggggcgaagtgccggggcagggatcctcgtcctcactcctgtctcctgc
gagaaagtatccatcctgatgcaatgcccggcctgctatcctgatcggctacctgccaitcaccaccaagcgaacatcgcga
tcgagcagcagctactcggatggaagccggctctgtcgaataggatgafctggacgaagagcatcaggggctcgcgccagccgaactg
ttcggcaggtcaaggcgcgatgccgacggcgatgatcctgctgacccatggcgatgectgcttgcgaatctatggtggaaatg
gcccgtttctggatcactgactgtggccggcctgggtgtgcccggaccctatcaggacatagcgttggctaccctgatattgctgaagag
cttggcgggcgaatgggctgaccgctctcctgcttcttaoggtatcgcgctcccgatcgcagcgcacgcctctctatgccttctgacgagt
tcttctgaggggatccgctgtaagctgcagaaatgatgatctatfaaacataaagatgtccactaaaatggaagtttctctgcatactttgtt
aagaagggtgagaacagagtacctacatfttgaatggaaggattggagctacgggggtgggggtgggggtgggattagataaatgcctgct
cttactgaaggctcttctactattgciftatgataatgttcatagttg

FIG. 50G

gatataaaittaaacaaagcaaaaccaaaitaagggccagctcattectcccactcatgatctatagatctatagatctctcgtgggatcattgt
ttttcttctgattcccactttgtgggttaagtaactgtggtttccaaatgtgtcagtttcatagcctgaagaacgagatcagcagcctctgtccaca
tacacttcattctcagtaattgtttgccaagttcfaatfccatcagaaagc

pPGK-DTA

TACCGGGTAGGGGAGGCGCTTTTCCcAAGGCAGTCTGgAGCATGCGCtTTAGCAGCCC
CGCTgGGCACTTGGCGCTACACAAGTGGCCTCTGGCCTCGCACACATTCCACATCCA
CCGGTAGGGGCCAACCGGCTCCGTTCTTTGGTGGCCCCCTTCGCGCCACCTTCTACTCC
TCCCCTAGTCAGGAAGTTCCCCCCCCGCCCGCAGCTCGCGTCGTGcAGGACGTGACA
AATGGAAGTAGCACGTCTCACTAGTCTCGTgCAGATGGACAGCACCGCTGAGCAATG
GAAGCGGGTAGGCCCTTTGGGGCAGCGGCCAATAGCAGCTTTGCTCCTTCGCTTTCTG
GGCTCAGAGGCTGGGAAGGGGTGGGTCCGGGGGGCGGGCTCAGGGGGCGGGCTCAGG
GGCGGGGCGGGCGCCCGAAGGTCCCTCCGGAGGCCCGGCATTCTGCACGCTTCAAAA
GCGCACGTCTGCCGCGCTGTTCTCCTCTTCCTCATCTCCGGGCCTTTCGACCTGCAGG
TCCTCGCCATggatcctgatgatgttgttGattctctaaAtctttgtGatggaaaacttttcttctgaccacgggactaaacctggtt
atgtagattccattcaaaaaggatatacaaaaagccaaaatctggfacacaaggaaatfatgacgatgattggaagggtttatagfaccgacaa
taaatacgacgctcgggatactctgtagataatgaaaaccgctctctggaaaagctggaggcgtggtcaaagtgcgfatccaggactg
acgaagggtctcgcactaaaagtggaataatccgaaactaataagaaagagttaggttaagtctcactgaaccgtgatggagcaagtcgga
acggaagagttaataaaaaggtcgggtgatggtgcttcgctgtagtgcicagccttcccttcgctgaggggagttctagcgttgaatalataa
taactgggaacaggcgaaagcgttaagcgtagaacttgagattaatttgaaacccgtggaaaacgtggccaagatgcatgatgatgagtata
tggctcaagcctgtgcaggaaatcgtgcaggcgatctctttgtgaaggaaaccttctctgtggtgtgacataattggacaactacctacag
agattaaagctc taaggtaataataaaattttaagtgataatgtgttaactactgattc taattgttgtgattitagattccaacctatggaact
gatgaatgggagcagtggtggaatgcagatccagagctcgtgatcagcctcactgtgcttctagttgccagccatctgtgtttgccct
ccccgtgcttcttgacctggaagggtgcactcccactgtccttcttaataaaatgaggaaattgcatcgcattgtctgagtaggtgtcat
tctattctgggggggtggggggggcaggacagcaagggggagggaftgggaagacaatagcagggcatg

FIG. 50H

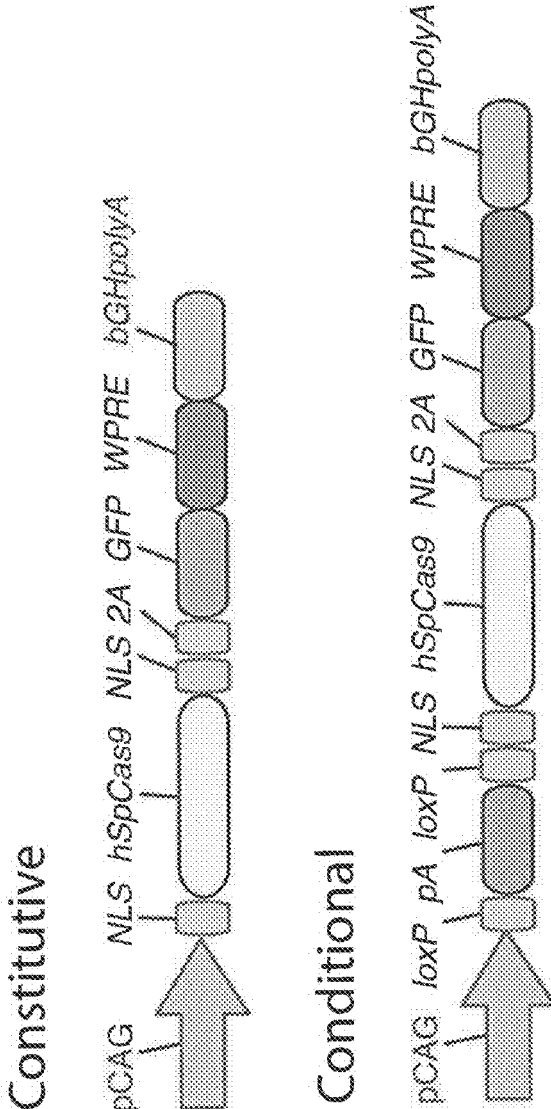

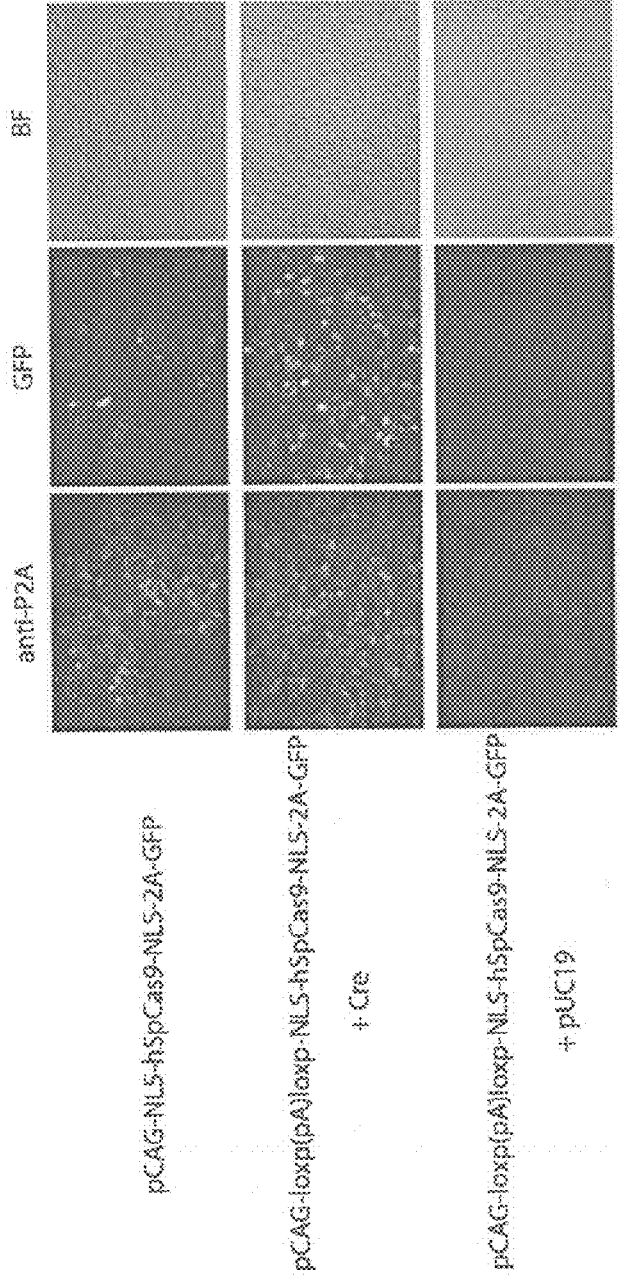

FIG. 52

Validation of Cas9 nuclease activity by Surveyor

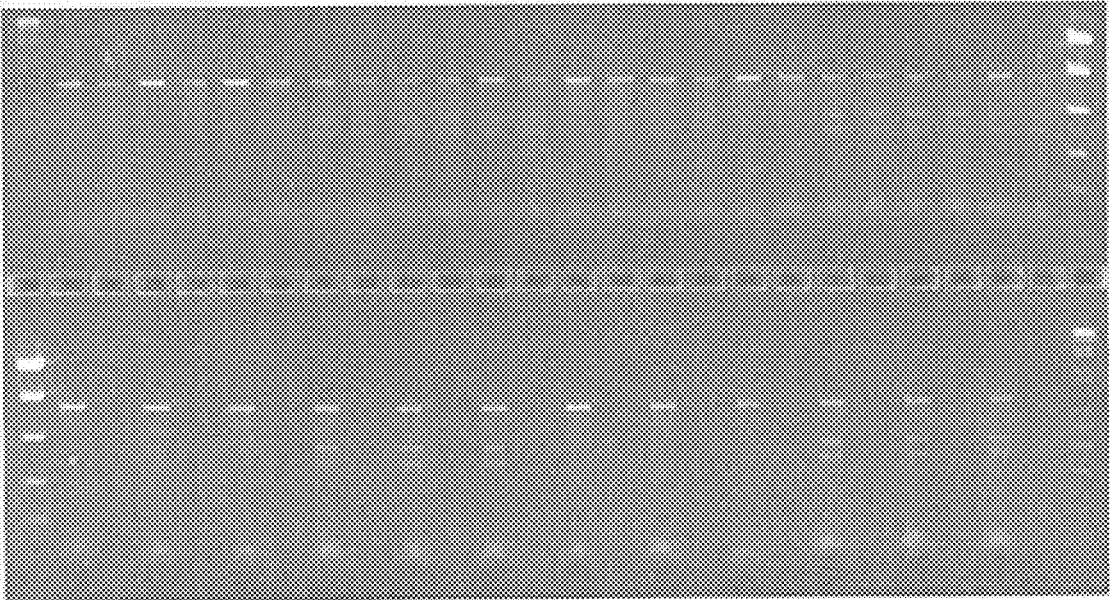

FIG. 53

		Average	StDev
pCAG-loxp(pA)loxp-NLS-hSpCas9-NLS-2A-GFP	Clone 1	32.1	7.1
	Clone 2	27.3	3.5
	Clone 3	35.9	1.4
	Clone 4	39.0	4.7
pCAG-NLS-hSpCas9-NLS-2A-GFP	Clone 1	26.9	1.3
	Clone 2	33.1	2.7

FIG. 54

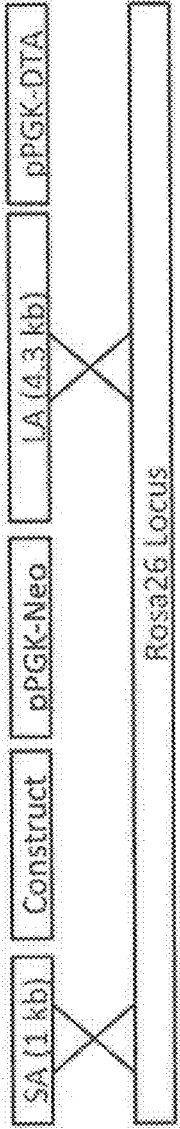

FIG. 55

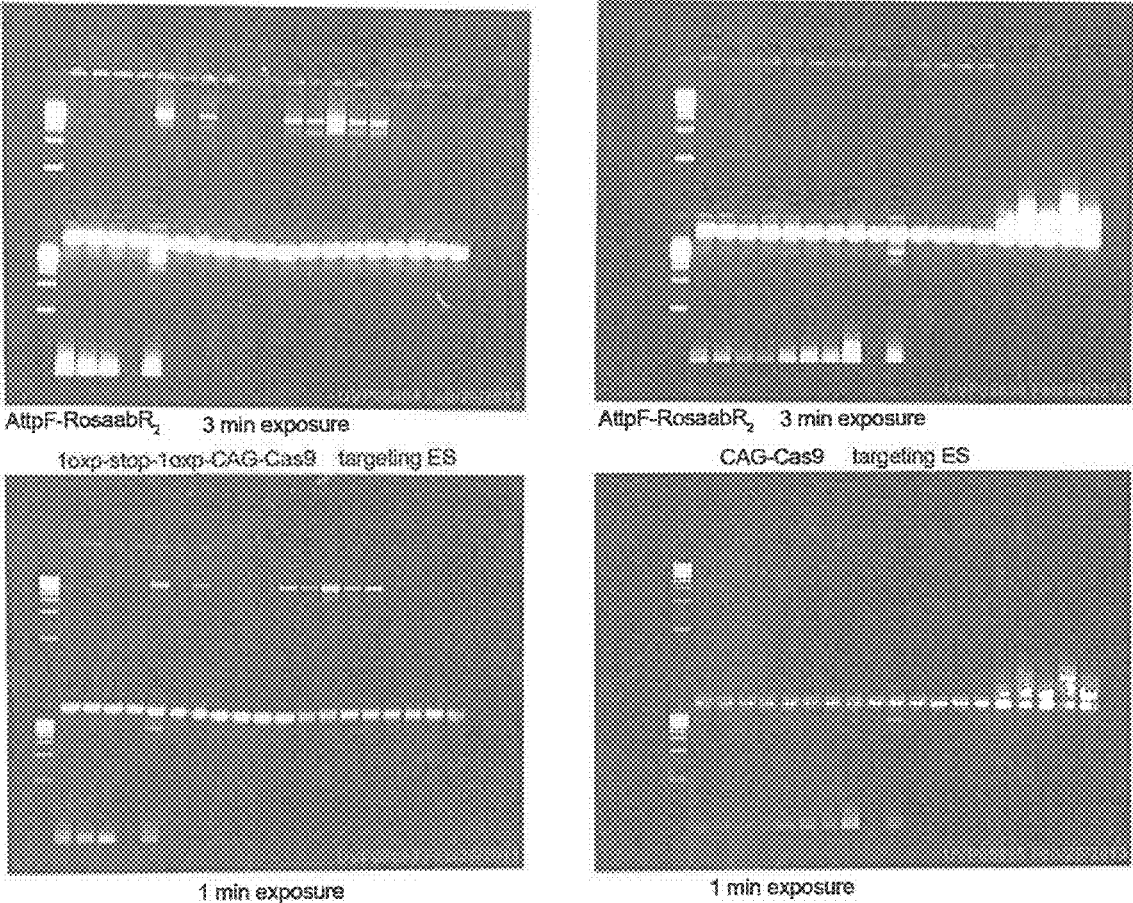

FIG. 56

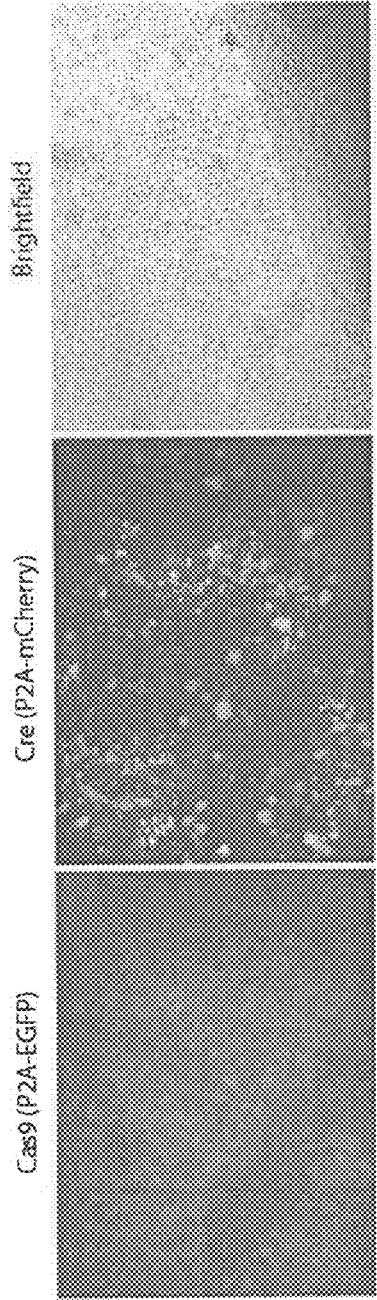

FIG. 57

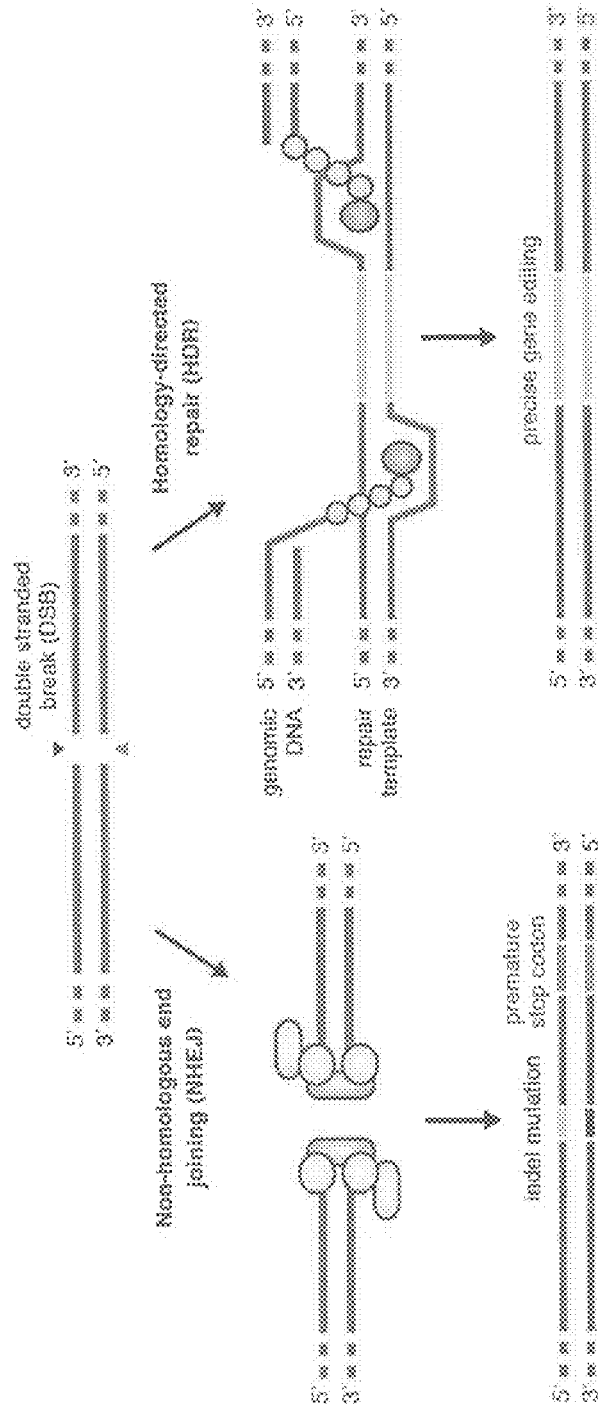

FIG. 59

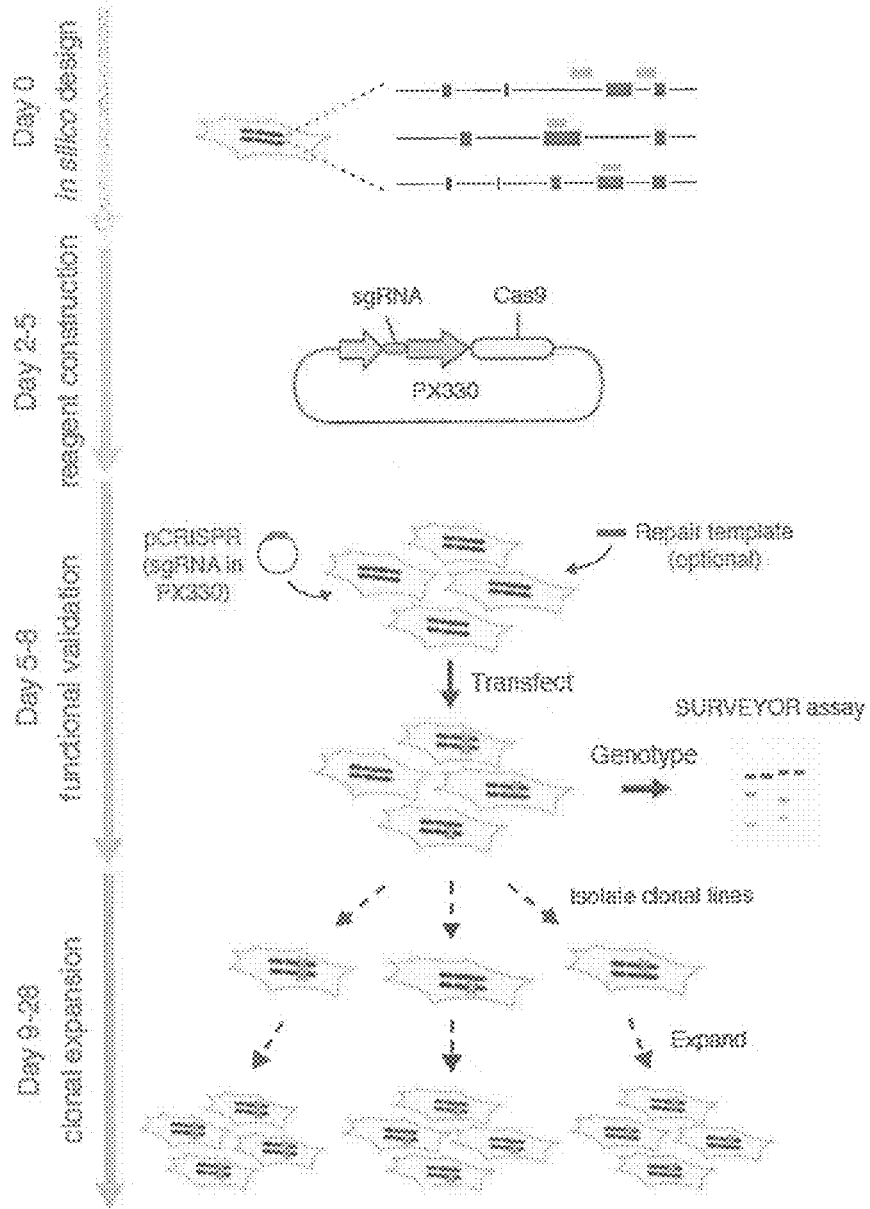

FIG. 60

FIG. 62A

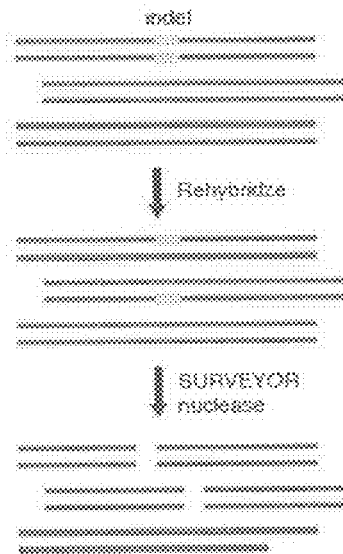

FIG. 62B

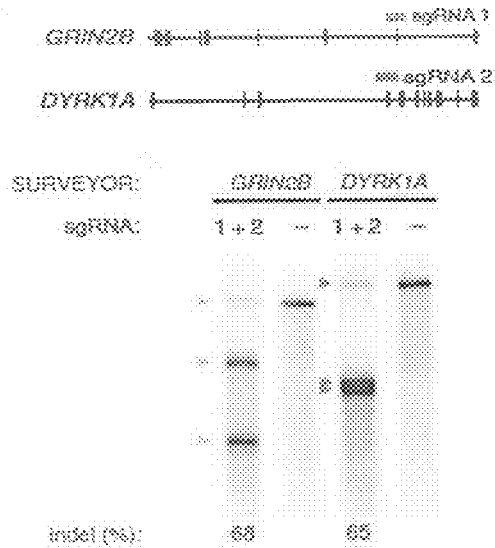

FIG. 62C

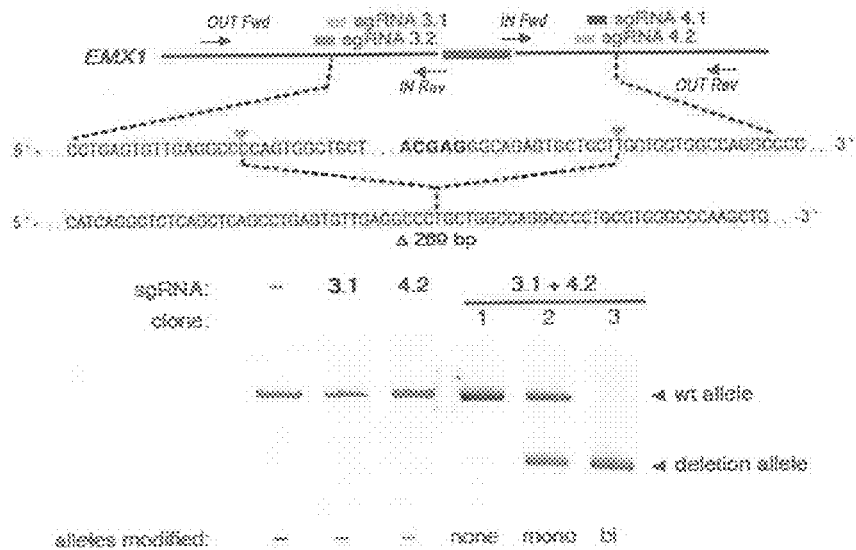

FIG. 62D

sgRNAs	Approx. deletion size (bp)	Number of clones				Total
		+/+	Δ/+	Δ/Δ	Inversion	
3.1 + 4.1	282	12	10	1	0	23
3.2 + 4.1	237	20	16	2	0	38
3.1 + 4.2	425	4	14	5	0	23
3.2 + 4.2	259	5	11	4	0	21

FIG. 63A

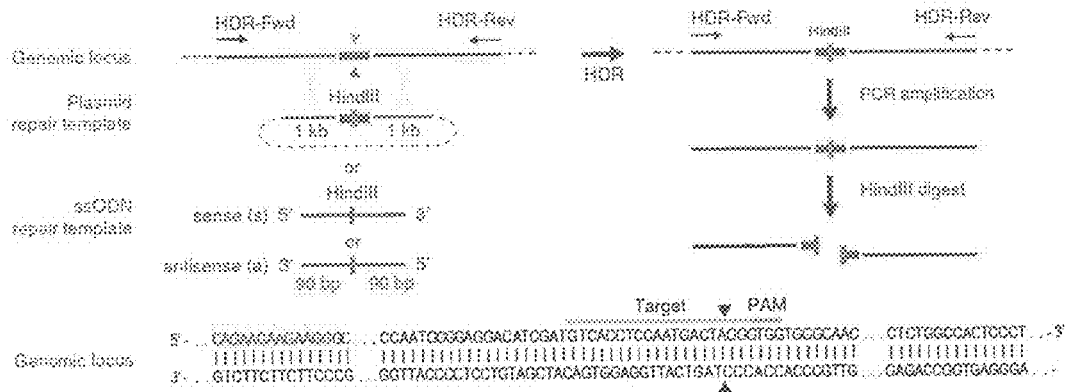

FIG. 63B

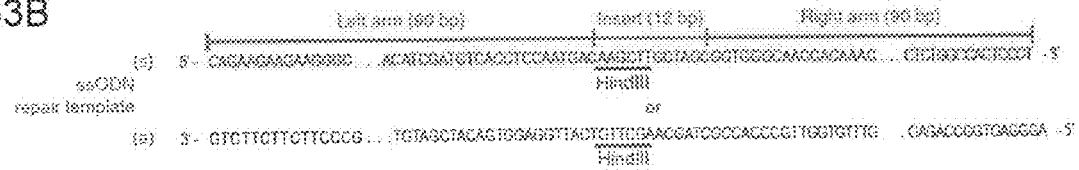
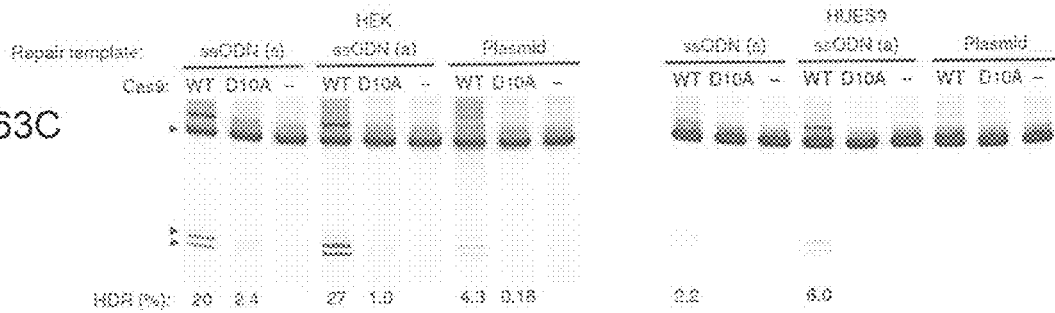

FIG. 63C



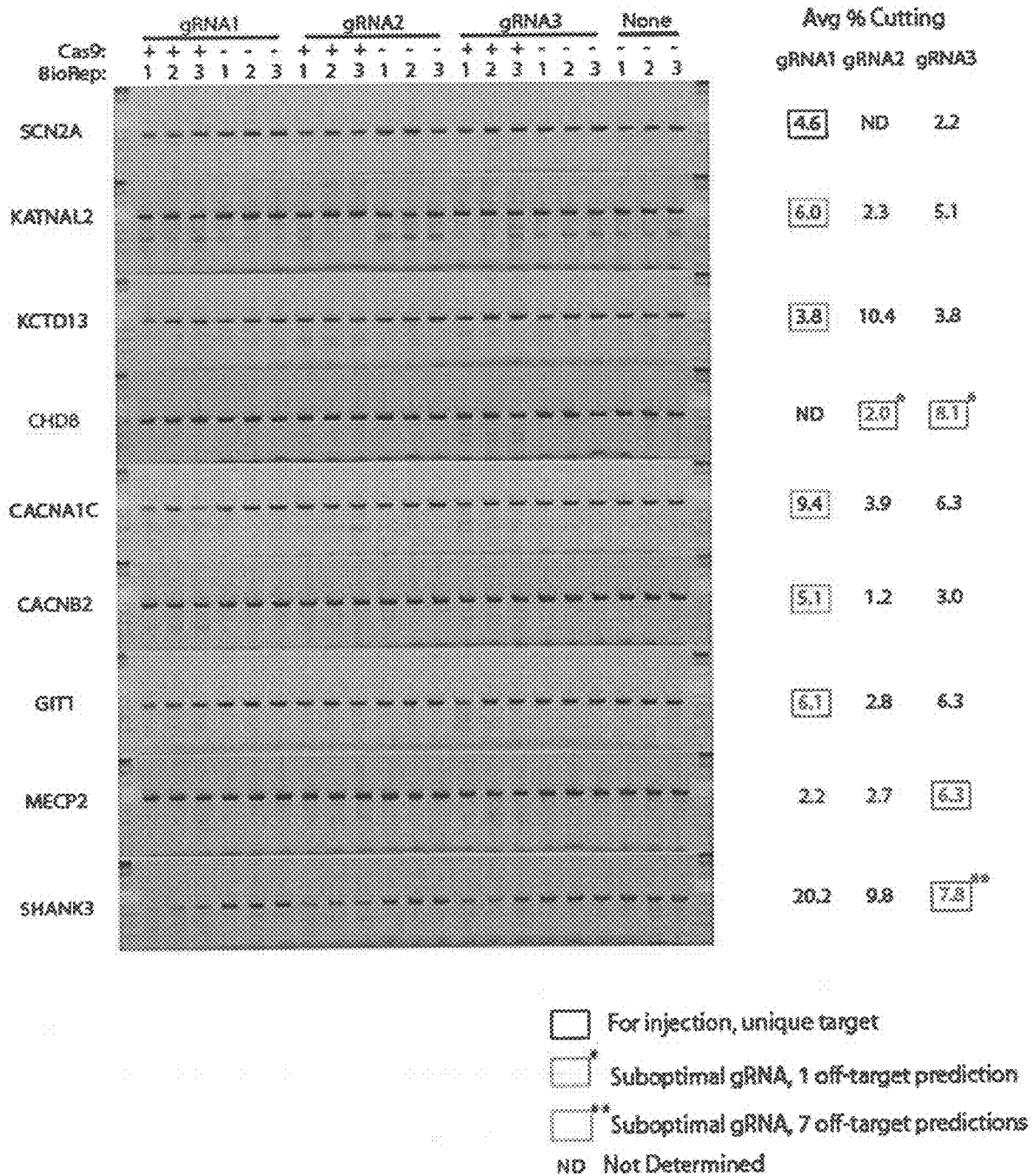
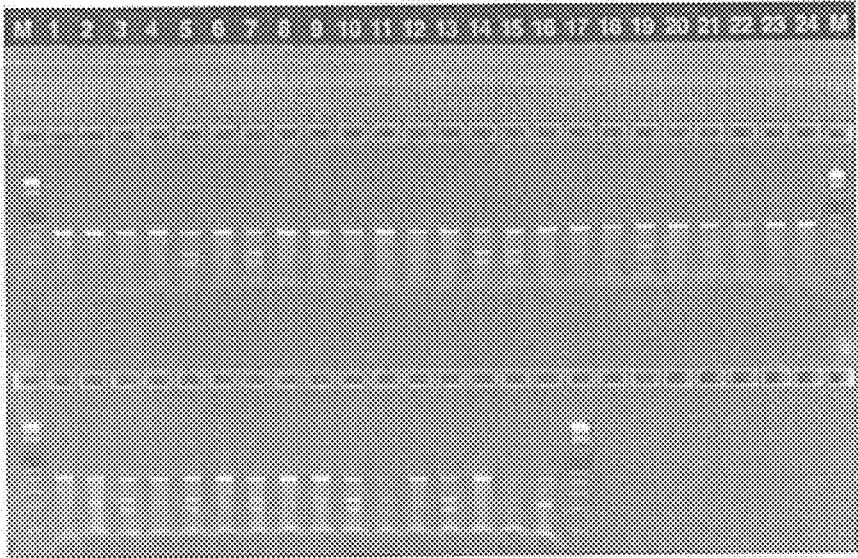

FIG. 65



gRNA sequences for Chd8 targeting:

- Chd8.1 - agctgtttactggtcggct
- Chd8.2 - aatggatacacctggtcgaa
- Chd8.3 - caatggatacacctggtcga

FIG. 66

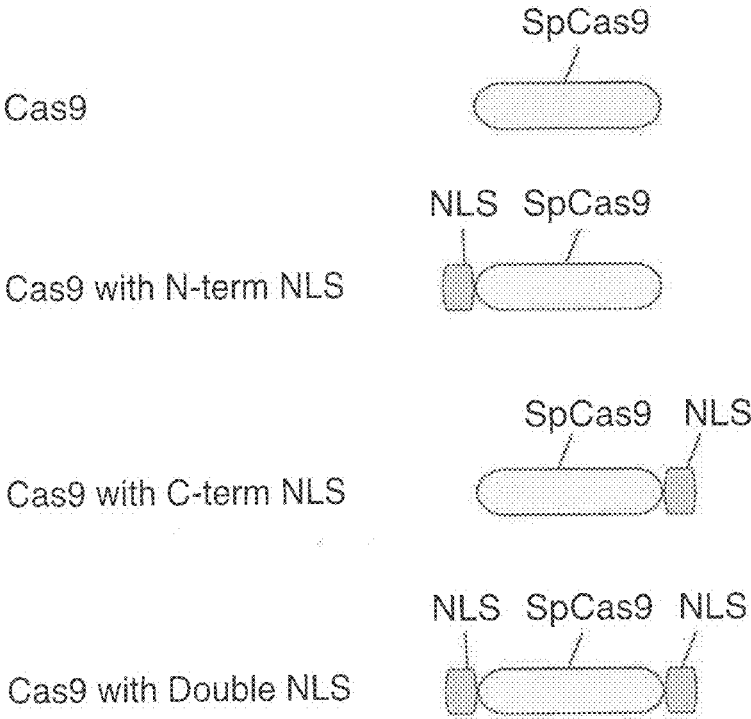

FIG. NLS1

FIG. 67

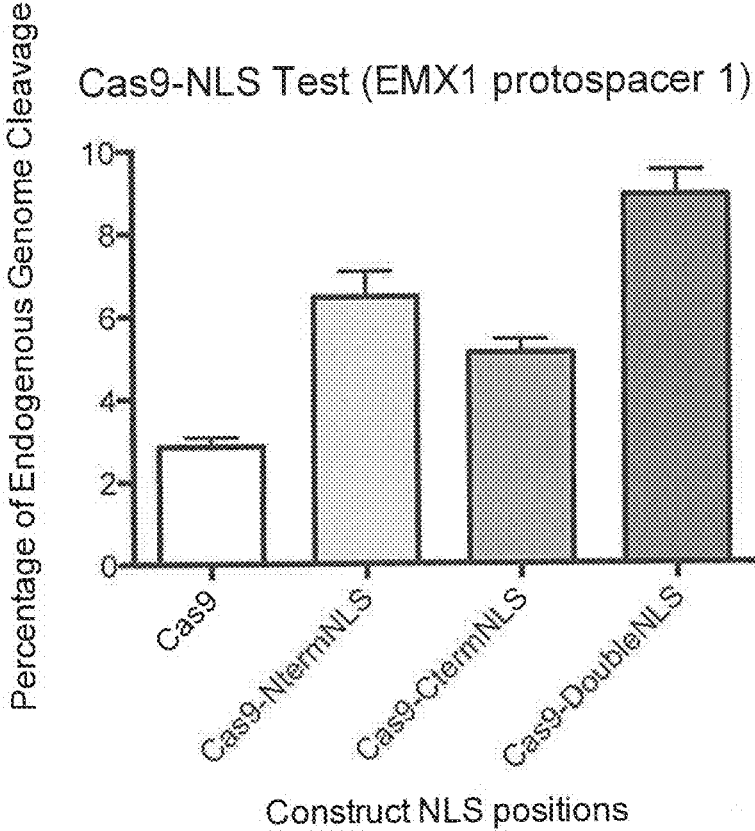

FIG. 68

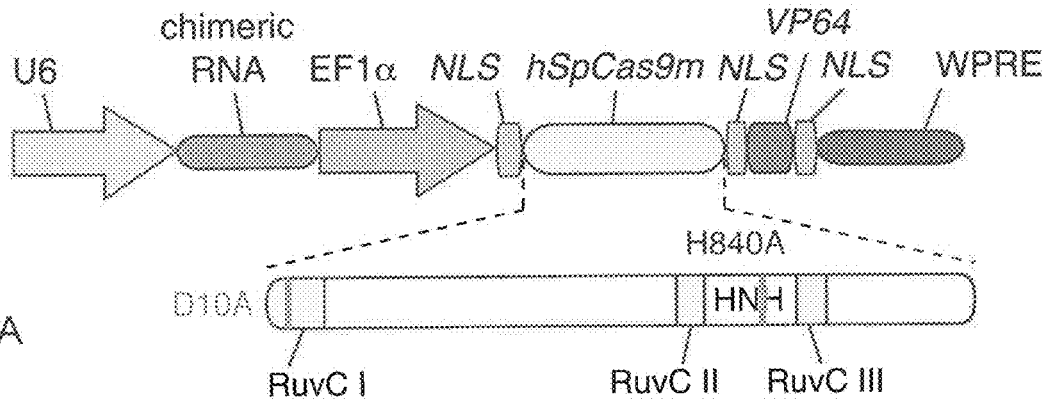
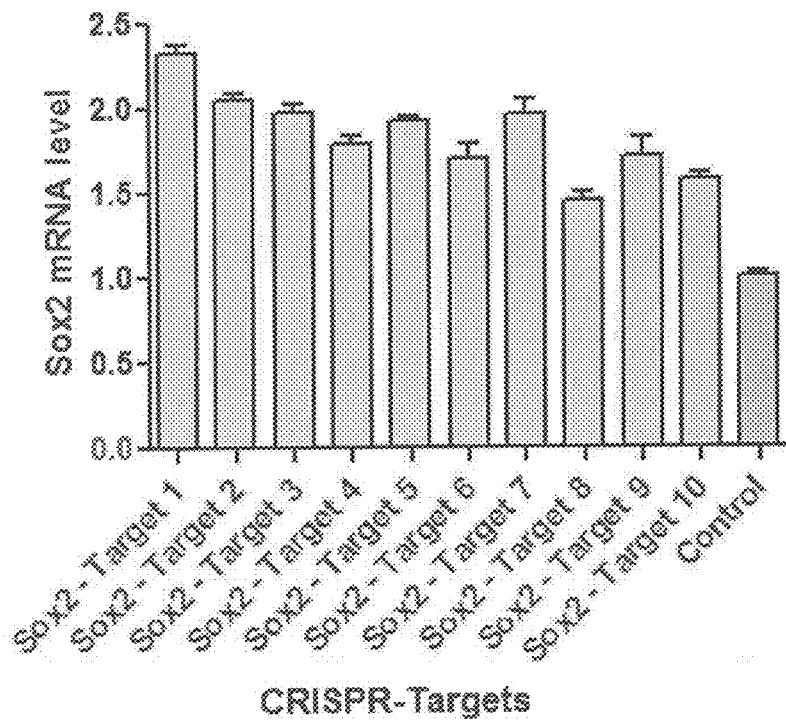

FIG. 69B



NLS architecture optimization for SpCas9

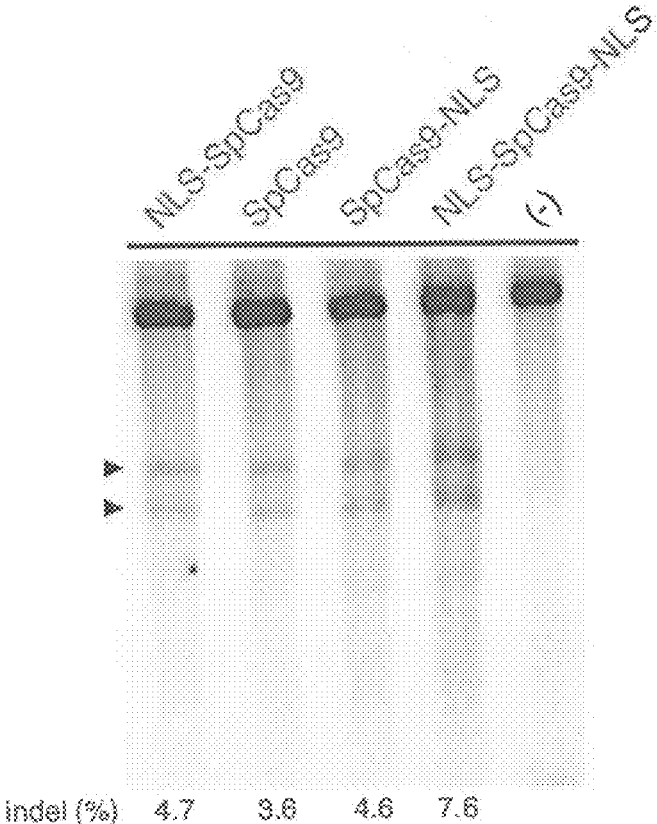
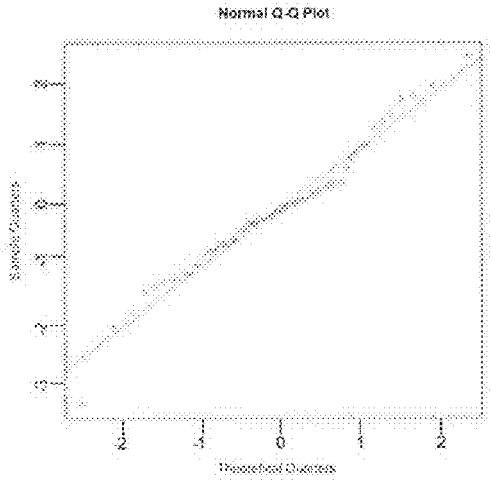

FIG. 70



QQ plot for the RGGNN sequences

FIG. 71

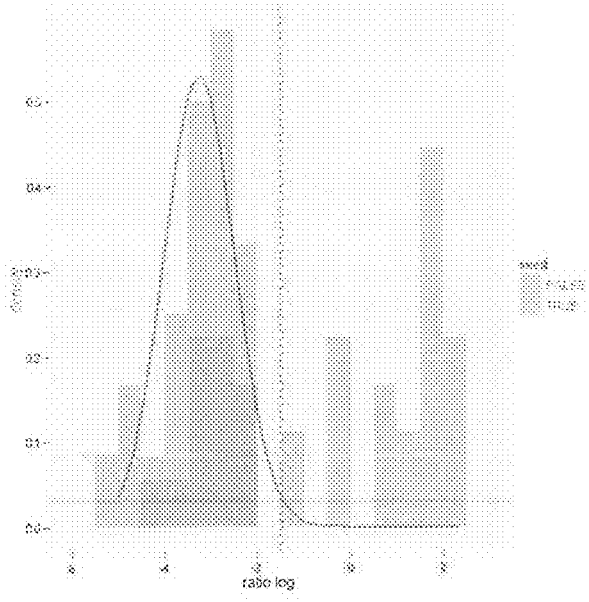

FIG. 72

FIG. 73A

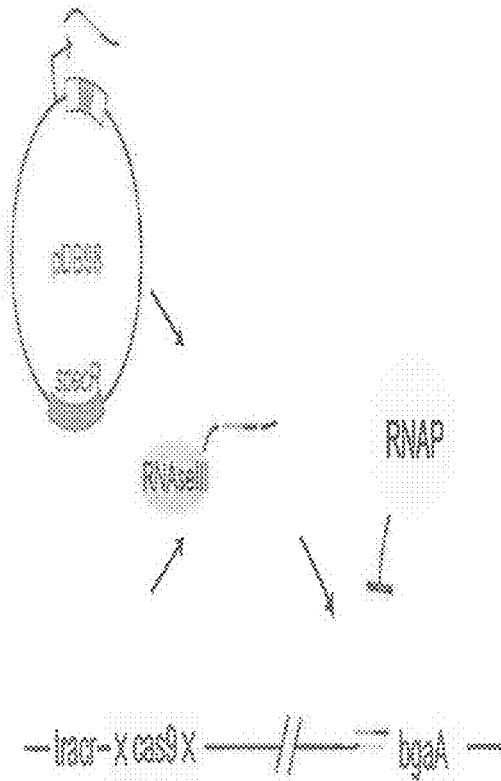

FIG. 73C

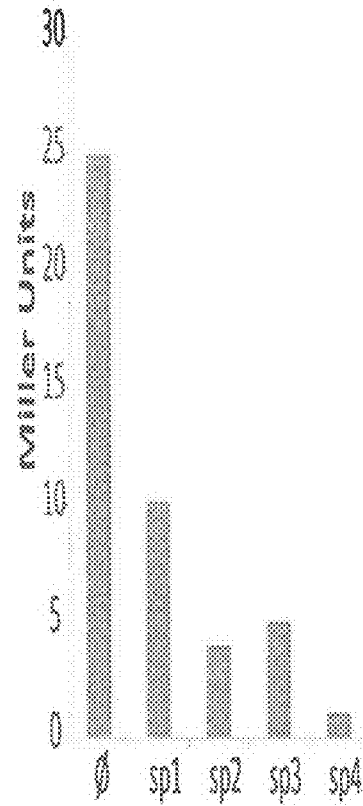

FIG. 73B

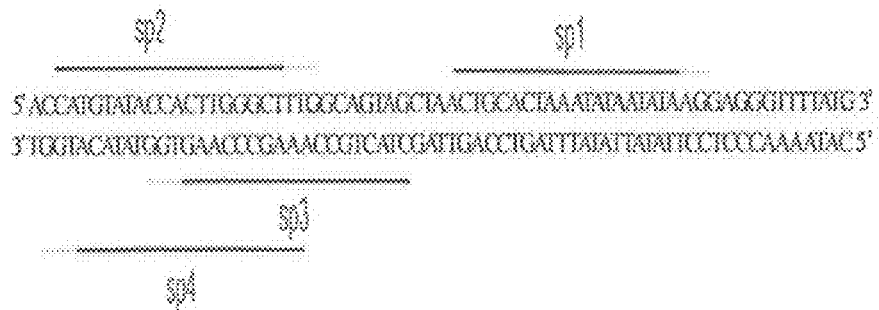

FIG. 74A

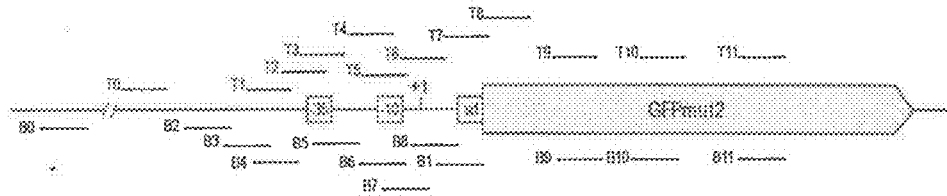

FIG. 74B

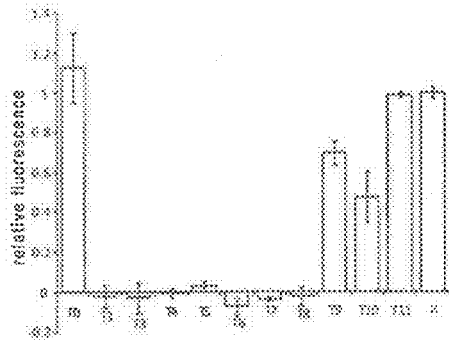

FIG. 74C

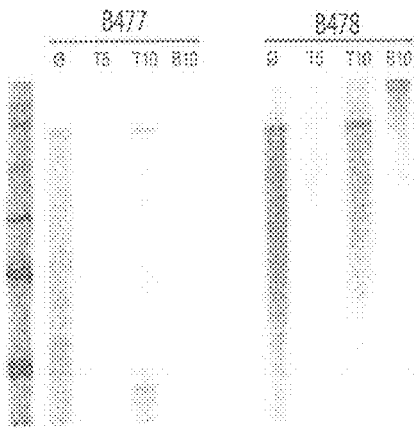
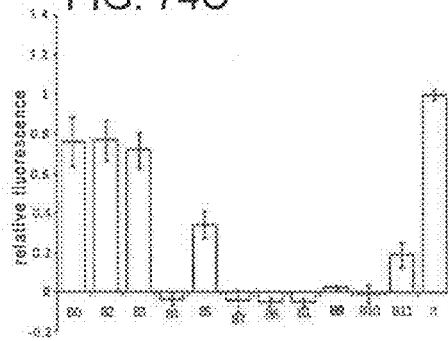

FIG. 74D

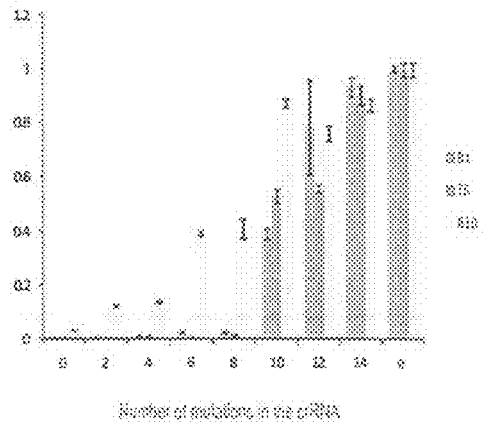

FIG. 74E

**CRISPR-CAS COMPONENT SYSTEMS,
METHODS AND COMPOSITIONS FOR
SEQUENCE MANIPULATION**

**RELATED APPLICATIONS AND
INCORPORATION BY REFERENCE**

[0001] This application is a continuation of U.S. application Ser. No. 15/230,161 filed Aug. 5, 2016, which is a continuation of U.S. application Ser. No. 14/105,035 filed Dec. 12, 2013, which claims priority to U.S. provisional patent applications 61/736,527, 61/748,427, 61/768,959, 61/791,409 and 61/835,931, all entitled SYSTEMS METHODS AND COMPOSITIONS FOR SEQUENCE MANIPULATION filed on Dec. 12, 2012, Jan. 2, 2013, Feb. 25, 2013, Mar. 15, 2013 and Jun. 17, 2013, respectively.

[0002] Reference is made to U.S. provisional patent applications 61/758,468; 61/769,046; 61/802,174; 61/806,375; 61/814,263; 61/819,803 and 61/828,130, each entitled ENGINEERING AND OPTIMIZATION OF SYSTEMS, METHODS AND COMPOSITIONS FOR SEQUENCE MANIPULATION, filed on Jan. 30, 2013; Feb. 25, 2013; Mar. 15, 2013; Mar. 28, 2013; Apr. 20, 2013; May 6, 2013 and May 28, 2013 respectively. Reference is also made to U.S. provisional patent applications 61/835,936, 61/836,127, 61/836,101, 61/836,080, 61/836,123 and 61/835,973 each filed Jun. 17, 2013. Reference is also made to U.S. provisional patent application 61/842,322 and U.S. patent application Ser. No. 14/054,414, each having Broad reference BI-2011/008A, entitled CRISPR-CAS SYSTEMS AND METHODS FOR ALTERING EXPRESSION OF GENE PRODUCTS filed on Jul. 2, 2013 and Oct. 15, 2013 respectively.

**STATEMENT AS TO FEDERALLY SPONSORED
RESEARCH**

[0003] This invention was made with government support under the NIH Pioneer Award DP1MH100706, awarded by the National Institutes of Health. The government has certain rights in the invention.

[0004] The foregoing applications, and all documents cited therein or during their prosecution (“appln cited documents”) and all documents cited or referenced in the appln cited documents, and all documents cited or referenced herein (“herein cited documents”), and all documents cited or referenced in herein cited documents, together with any manufacturer’s instructions, descriptions, product specifications, and product sheets for any products mentioned herein or in any document incorporated by reference herein, are hereby incorporated herein by reference, and may be employed in the practice of the invention. More specifically, all referenced documents are incorporated by reference to the same extent as if each individual document was specifically and individually indicated to be incorporated by reference.

SEQUENCE LISTING

[0005] The instant application contains a Sequence Listing which has been submitted electronically in ASCII format and is hereby incorporated by reference in its entirety. Said ASCII copy, created on Mar. 31, 2015, is named 44790.07.2003_SL.txt and is 308.802 bytes in size.

FIELD OF THE INVENTION

[0006] The present invention generally relates to systems, methods and compositions used for the control of gene expression involving sequence targeting, such as genome perturbation or gene-editing, that may use vector systems related to Clustered Regularly Interspaced Short Palindromic Repeats (CRISPR) and components thereof.

BACKGROUND OF THE INVENTION

[0007] Recent advances in genome sequencing techniques and analysis methods have significantly accelerated the ability to catalog and map genetic factors associated with a diverse range of biological functions and diseases. Precise genome targeting technologies are needed to enable systematic reverse engineering of causal genetic variations by allowing selective perturbation of individual genetic elements, as well as to advance synthetic biology, biotechnological, and medical applications. Although genome-editing techniques such as designer zinc fingers, transcription activator-like effectors (TALEs), or homing meganucleases are available for producing targeted genome perturbations, there remains a need for new genome engineering technologies that are affordable, easy to set up, scalable, and amenable to targeting multiple positions within the eukaryotic genome.

SUMMARY OF THE INVENTION

[0008] There exists a pressing need for alternative and robust systems and techniques for sequence targeting with a wide array of applications. This invention addresses this need and provides related advantages. The CRISPR/Cas or the CRISPR-Cas system (both terms are used interchangeably throughout this application) does not require the generation of customized proteins to target specific sequences but rather a single Cas enzyme can be programmed by a short RNA molecule to recognize a specific DNA target, in other words the Cas enzyme can be recruited to a specific DNA target using said short RNA molecule. Adding the CRISPR-Cas system to the repertoire of genome sequencing techniques and analysis methods may significantly simplify the methodology and accelerate the ability to catalog and map genetic factors associated with a diverse range of biological functions and diseases. To utilize the CRISPR-Cas system effectively for genome editing without deleterious effects, it is critical to understand aspects of engineering and optimization of these genome engineering tools, which are aspects of the claimed invention.

[0009] In one aspect, the invention provides a vector system comprising one or more vectors. In some embodiments, the system comprises: (a) a first regulatory element operably linked to a tracr mate sequence and one or more insertion sites for inserting one or more guide sequences upstream of the tracr mate sequence, wherein when expressed, the guide sequence directs sequence-specific binding of a CRISPR complex to a target sequence in a eukaryotic cell, wherein the CRISPR complex comprises a CRISPR enzyme complexed with (1) the guide sequence that is hybridized to the target sequence, and (2) the tracr mate sequence that is hybridized to the tracr sequence; and (b) a second regulatory element operably linked to an enzyme-coding sequence encoding said CRISPR enzyme comprising a nuclear localization sequence; wherein components (a) and (b) are located on the same or different vectors of the system. In some embodiments, component (a)

further comprises the tracr sequence downstream of the tracr mate sequence under the control of the first regulatory element. In some embodiments, component (a) further comprises two or more guide sequences operably linked to the first regulatory element, wherein when expressed, each of the two or more guide sequences direct sequence specific binding of a CRISPR complex to a different target sequence in a eukaryotic cell. In some embodiments, the system comprises the tracr sequence under the control of a third regulatory element, such as a polymerase III promoter. In some embodiments, the tracr sequence exhibits at least 50%, 60%, 70%, 80%, 90%, 95%, or 99% of sequence complementarity along the length of the tracr mate sequence when optimally aligned. Determining optimal alignment is within the purview of one of skill in the art. For example, there are publically and commercially available alignment algorithms and programs such as, but not limited to, ClustalW, Smith-Waterman in matlab, Bowtie, Geneious, Biopython and SeqMan. In some embodiments, the CRISPR complex comprises one or more nuclear localization sequences of sufficient strength to drive accumulation of said CRISPR complex in a detectable amount in the nucleus of a eukaryotic cell. Without wishing to be bound by theory, it is believed that a nuclear localization sequence is not necessary for CRISPR complex activity in eukaryotes, but that including such sequences enhances activity of the system, especially as to targeting nucleic acid molecules in the nucleus. In some embodiments, the CRISPR enzyme is a type II CRISPR system enzyme. In some embodiments, the CRISPR enzyme is a Cas9 enzyme. In some embodiments, the Cas9 enzyme is *S. pneumoniae*, *S. pyogenes*, or *S. thermophilus* Cas9, and may include mutated Cas9 derived from these organisms. The enzyme may be a Cas9 homolog or ortholog. In some embodiments, the CRISPR enzyme is codon-optimized for expression in a eukaryotic cell. In some embodiments, the CRISPR enzyme directs cleavage of one or two strands at the location of the target sequence. In some embodiments, the CRISPR enzyme lacks DNA strand cleavage activity. In some embodiments, the first regulatory element is a polymerase III promoter. In some embodiments, the second regulatory element is a polymerase II promoter. In some embodiments, the guide sequence is at least 15, 16, 17, 18, 19, 20, 25 nucleotides, or between 10-30, or between 15-25, or between 15-20 nucleotides in length. In general, and throughout this specification, the term “vector” refers to a nucleic acid molecule capable of transporting another nucleic acid to which it has been linked. Vectors include, but are not limited to, nucleic acid molecules that are single-stranded, double-stranded, or partially double-stranded; nucleic acid molecules that comprise one or more free ends, no free ends (e.g. circular); nucleic acid molecules that comprise DNA, RNA, or both; and other varieties of polynucleotides known in the art. One type of vector is a “plasmid,” which refers to a circular double stranded DNA loop into which additional DNA segments can be inserted, such as by standard molecular cloning techniques. Another type of vector is a viral vector, wherein virally-derived DNA or RNA sequences are present in the vector for packaging into a virus (e.g. retroviruses, replication defective retroviruses, adenoviruses, replication defective adenoviruses, and adeno-associated viruses). Viral vectors also include polynucleotides carried by a virus for transfection into a host cell. Certain vectors are capable of autonomous replication in a host cell into which they are introduced (e.g. bacterial

vectors having a bacterial origin of replication and episomal mammalian vectors). Other vectors (e.g., non-episomal mammalian vectors) are integrated into the genome of a host cell upon introduction into the host cell, and thereby are replicated along with the host genome. Moreover, certain vectors are capable of directing the expression of genes to which they are operatively-linked. Such vectors are referred to herein as “expression vectors.” Common expression vectors of utility in recombinant DNA techniques are often in the form of plasmids.

[0010] Recombinant expression vectors can comprise a nucleic acid of the invention in a form suitable for expression of the nucleic acid in a host cell, which means that the recombinant expression vectors include one or more regulatory elements, which may be selected on the basis of the host cells to be used for expression, that is operatively-linked to the nucleic acid sequence to be expressed. Within a recombinant expression vector, “operably linked” is intended to mean that the nucleotide sequence of interest is linked to the regulatory element(s) in a manner that allows for expression of the nucleotide sequence (e.g. in an in vitro transcription/translation system or in a host cell when the vector is introduced into the host cell).

[0011] The term “regulatory element” is intended to include promoters, enhancers, internal ribosomal entry sites (IRES), and other expression control elements (e.g. transcription termination signals, such as polyadenylation signals and poly-U sequences). Such regulatory elements are described, for example, in Goeddel, GENE EXPRESSION TECHNOLOGY: METHODS IN ENZYMOLOGY 185, Academic Press, San Diego, Calif. (1990). Regulatory elements include those that direct constitutive expression of a nucleotide sequence in many types of host cell and those that direct expression of the nucleotide sequence only in certain host cells (e.g., tissue-specific regulatory sequences). A tissue-specific promoter may direct expression primarily in a desired tissue of interest, such as muscle, neuron, bone, skin, blood, specific organs (e.g. liver, pancreas), or particular cell types (e.g. lymphocytes). Regulatory elements may also direct expression in a temporal-dependent manner, such as in a cell-cycle dependent or developmental stage-dependent manner, which may or may not also be tissue or cell-type specific. In some embodiments, a vector comprises one or more pol III promoter (e.g. 1, 2, 3, 4, 5, or more pol III promoters), one or more pol II promoters (e.g. 1, 2, 3, 4, 5, or more pol II promoters), one or more pol I promoters (e.g. 1, 2, 3, 4, 5, or more pol I promoters), or combinations thereof. Examples of pol III promoters include, but are not limited to, U6 and H1 promoters. Examples of pol II promoters include, but are not limited to, the retroviral Rous sarcoma virus (RSV) LTR promoter (optionally with the RSV enhancer), the cytomegalovirus (CMV) promoter (optionally with the CMV enhancer) [see, e.g., Boshart et al, Cell, 41:521-530 (1985)], the SV40 promoter, the dihydrofolate reductase promoter, the β -actin promoter, the phosphoglycerol kinase (PGK) promoter, and the EF1 α promoter. Also encompassed by the term “regulatory element” are enhancer elements, such as WPRE; CMV enhancers; the R-U5' segment in LTR of HTLV-I (Mol. Cell. Biol., Vol. 8(1), p. 466-472, 1988); SV40 enhancer; and the intron sequence between exons 2 and 3 of rabbit 3-globin (Proc. Natl. Acad. Sci. USA., Vol. 78(3), p. 1527-31, 1981). It will be appreciated by those skilled in the art that the design of the expression vector can depend on such factors as the

choice of the host cell to be transformed, the level of expression desired, etc. A vector can be introduced into host cells to thereby produce transcripts, proteins, or peptides, including fusion proteins or peptides, encoded by nucleic acids as described herein (e.g., clustered regularly interspersed short palindromic repeats (CRISPR) transcripts, proteins, enzymes, mutant forms thereof, fusion proteins thereof, etc.).

[0012] Advantageous vectors include lentiviruses and adeno-associated viruses, and types of such vectors can also be selected for targeting particular types of cells.

[0013] In one aspect, the invention provides a vector comprising a regulatory element operably linked to an enzyme-coding sequence encoding a CRISPR enzyme comprising one or more nuclear localization sequences. In some embodiments, said regulatory element drives transcription of the CRISPR enzyme in a eukaryotic cell such that said CRISPR enzyme accumulates in a detectable amount in the nucleus of the eukaryotic cell. In some embodiments, the regulatory element is a polymerase II promoter. In some embodiments, the CRISPR enzyme is a type II CRISPR system enzyme. In some embodiments, the CRISPR enzyme is a Cas9 enzyme. In some embodiments, the Cas9 enzyme is *S. pneumoniae*, *S. pyogenes* or *S. thermophilus* Cas9, and may include mutated Cas9 derived from these organisms. In some embodiments, the CRISPR enzyme is codon-optimized for expression in a eukaryotic cell. In some embodiments, the CRISPR enzyme directs cleavage of one or two strands at the location of the target sequence. In some embodiments, the CRISPR enzyme lacks DNA strand cleavage activity.

[0014] In one aspect, the invention provides a CRISPR enzyme comprising one or more nuclear localization sequences of sufficient strength to drive accumulation of said CRISPR enzyme in a detectable amount in the nucleus of a eukaryotic cell. In some embodiments, the CRISPR enzyme is a type II CRISPR system enzyme. In some embodiments, the CRISPR enzyme is a Cas9 enzyme. In some embodiments, the Cas9 enzyme is *S. pneumoniae*, *S. pyogenes* or *S. thermophilus* Cas9, and may include mutated Cas9 derived from these organisms. The enzyme may be a Cas9 homolog or ortholog. In some embodiments, the CRISPR enzyme lacks the ability to cleave one or more strands of a target sequence to which it binds.

[0015] In one aspect, the invention provides a eukaryotic host cell comprising (a) a first regulatory element operably linked to a tracr mate sequence and one or more insertion sites for inserting one or more guide sequences upstream of the tracr mate sequence, wherein when expressed, the guide sequence directs sequence-specific binding of a CRISPR complex to a target sequence in a eukaryotic cell, wherein the CRISPR complex comprises a CRISPR enzyme complexed with (1) the guide sequence that is hybridized to the target sequence, and (2) the tracr mate sequence that is hybridized to the tracr sequence; and/or (b) a second regulatory element operably linked to an enzyme-coding sequence encoding said CRISPR enzyme comprising a nuclear localization sequence. In some embodiments, the host cell comprises components (a) and (b). In some embodiments, component (a), component (b), or components (a) and (b) are stably integrated into a genome of the host eukaryotic cell. In some embodiments, component (a) further comprises the tracr sequence downstream of the tracr mate sequence under the control of the first regulatory

element. In some embodiments, component (a) further comprises two or more guide sequences operably linked to the first regulatory element, wherein when expressed, each of the two or more guide sequences direct sequence specific binding of a CRISPR complex to a different target sequence in a eukaryotic cell. In some embodiments, the eukaryotic host cell further comprises a third regulatory element, such as a polymerase III promoter, operably linked to said tracr sequence. In some embodiments, the tracr sequence exhibits at least 50%, 60%, 70%, 80%, 90%, 95%, or 99% of sequence complementarity along the length of the tracr mate sequence when optimally aligned. In some embodiments, the CRISPR enzyme comprises one or more nuclear localization sequences of sufficient strength to drive accumulation of said CRISPR enzyme in a detectable amount in the nucleus of a eukaryotic cell. In some embodiments, the CRISPR enzyme is a type II CRISPR system enzyme. In some embodiments, the CRISPR enzyme is a Cas9 enzyme. In some embodiments, the Cas9 enzyme is *S. pneumoniae*, *S. pyogenes* or *S. thermophilus* Cas9, and may include mutated Cas9 derived from these organisms. The enzyme may be a Cas9 homolog or ortholog. In some embodiments, the CRISPR enzyme is codon-optimized for expression in a eukaryotic cell. In some embodiments, the CRISPR enzyme directs cleavage of one or two strands at the location of the target sequence. In some embodiments, the CRISPR enzyme lacks DNA strand cleavage activity. In some embodiments, the first regulatory element is a polymerase III promoter. In some embodiments, the second regulatory element is a polymerase II promoter. In some embodiments, the guide sequence is at least 15, 16, 17, 18, 19, 20, 25 nucleotides, or between 10-30, or between 15-25, or between 15-20 nucleotides in length. In an aspect, the invention provides a non-human eukaryotic organism; preferably a multicellular eukaryotic organism, comprising a eukaryotic host cell according to any of the described embodiments. In other aspects, the invention provides a eukaryotic organism; preferably a multicellular eukaryotic organism, comprising a eukaryotic host cell according to any of the described embodiments. The organism in some embodiments of these aspects may be an animal; for example a mammal. Also, the organism may be an arthropod such as an insect. The organism also may be a plant. Further, the organism may be a fungus.

[0016] In one aspect, the invention provides a kit comprising one or more of the components described herein. In some embodiments, the kit comprises a vector system and instructions for using the kit. In some embodiments, the vector system comprises (a) a first regulatory element operably linked to a tracr mate sequence and one or more insertion sites for inserting one or more guide sequences upstream of the tracr mate sequence, wherein when expressed, the guide sequence directs sequence-specific binding of a CRISPR complex to a target sequence in a eukaryotic cell, wherein the CRISPR complex comprises a CRISPR enzyme complexed with (1) the guide sequence that is hybridized to the target sequence, and (2) the tracr mate sequence that is hybridized to the tracr sequence; and/or (b) a second regulatory element operably linked to an enzyme-coding sequence encoding said CRISPR enzyme comprising a nuclear localization sequence. In some embodiments, the kit comprises components (a) and (b) located on the same or different vectors of the system. In some embodiments, component (a) further comprises the

tracr sequence downstream of the tracr mate sequence under the control of the first regulatory element. In some embodiments, component (a) further comprises two or more guide sequences operably linked to the first regulatory element, wherein when expressed, each of the two or more guide sequences direct sequence specific binding of a CRISPR complex to a different target sequence in a eukaryotic cell. In some embodiments, the system further comprises a third regulatory element, such as a polymerase III promoter, operably linked to said tracr sequence. In some embodiments, the tracr sequence exhibits at least 50%, 60%, 70%, 80%, 90%, 95%, or 99% of sequence complementarity along the length of the tracr mate sequence when optimally aligned. In some embodiments, the CRISPR enzyme comprises one or more nuclear localization sequences of sufficient strength to drive accumulation of said CRISPR enzyme in a detectable amount in the nucleus of a eukaryotic cell. In some embodiments, the CRISPR enzyme is a type II CRISPR system enzyme. In some embodiments, the CRISPR enzyme is a Cas9 enzyme. In some embodiments, the Cas9 enzyme is *S. pneumoniae*, *S. pyogenes* or *S. thermophilus* Cas9, and may include mutated Cas9 derived from these organisms. The enzyme may be a Cas9 homolog or ortholog. In some embodiments, the CRISPR enzyme is codon-optimized for expression in a eukaryotic cell. In some embodiments, the CRISPR enzyme directs cleavage of one or two strands at the location of the target sequence. In some embodiments, the CRISPR enzyme lacks DNA strand cleavage activity. In some embodiments, the first regulatory element is a polymerase III promoter. In some embodiments, the second regulatory element is a polymerase II promoter. In some embodiments, the guide sequence is at least 15, 16, 17, 18, 19, 20, 25 nucleotides, or between 10-30, or between 15-25, or between 15-20 nucleotides in length.

[0017] In one aspect, the invention provides a method of modifying a target polynucleotide in a eukaryotic cell. In some embodiments, the method comprises allowing a CRISPR complex to bind to the target polynucleotide to effect cleavage of said target polynucleotide thereby modifying the target polynucleotide, wherein the CRISPR complex comprises a CRISPR enzyme complexed with a guide sequence hybridized to a target sequence within said target polynucleotide, wherein said guide sequence is linked to a tracr mate sequence which in turn hybridizes to a tracr sequence. In some embodiments, said cleavage comprises cleaving one or two strands at the location of the target sequence by said CRISPR enzyme. In some embodiments, said cleavage results in decreased transcription of a target gene. In some embodiments, the method further comprises repairing said cleaved target polynucleotide by homologous recombination with an exogenous template polynucleotide, wherein said repair results in a mutation comprising an insertion, deletion, or substitution of one or more nucleotides of said target polynucleotide. In some embodiments, said mutation results in one or more amino acid changes in a protein expressed from a gene comprising the target sequence. In some embodiments, the method further comprises delivering one or more vectors to said eukaryotic cell, wherein the one or more vectors drive expression of one or more of: the CRISPR enzyme, the guide sequence linked to the tracr mate sequence, and the tracr sequence. In some embodiments, said vectors are delivered to the eukaryotic cell in a subject. In some embodiments, said modifying takes place in said eukaryotic cell in a cell culture. In some

embodiments, the method further comprises isolating said eukaryotic cell from a subject prior to said modifying. In some embodiments, the method further comprises returning said eukaryotic cell and/or cells derived therefrom to said subject.

[0018] In one aspect, the invention provides a method of modifying expression of a polynucleotide in a eukaryotic cell. In some embodiments, the method comprises allowing a CRISPR complex to bind to the polynucleotide such that said binding results in increased or decreased expression of said polynucleotide; wherein the CRISPR complex comprises a CRISPR enzyme complexed with a guide sequence hybridized to a target sequence within said polynucleotide, wherein said guide sequence is linked to a tracr mate sequence which in turn hybridizes to a tracr sequence. In some embodiments, the method further comprises delivering one or more vectors to said eukaryotic cells, wherein the one or more vectors drive expression of one or more of: the CRISPR enzyme, the guide sequence linked to the tracr mate sequence, and the tracr sequence.

[0019] In one aspect, the invention provides a method of generating a model eukaryotic cell comprising a mutated disease gene. In some embodiments, a disease gene is any gene associated an increase in the risk of having or developing a disease. In some embodiments, the method comprises (a) introducing one or more vectors into a eukaryotic cell, wherein the one or more vectors drive expression of one or more of: a CRISPR enzyme, a guide sequence linked to a tracr mate sequence, and a tracr sequence; and (b) allowing a CRISPR complex to bind to a target polynucleotide to effect cleavage of the target polynucleotide within said disease gene, wherein the CRISPR complex comprises the CRISPR enzyme complexed with (1) the guide sequence that is hybridized to the target sequence within the target polynucleotide, and (2) the tracr mate sequence that is hybridized to the tracr sequence, thereby generating a model eukaryotic cell comprising a mutated disease gene. In some embodiments, said cleavage comprises cleaving one or two strands at the location of the target sequence by said CRISPR enzyme. In some embodiments, said cleavage results in decreased transcription of a target gene. In some embodiments, the method further comprises repairing said cleaved target polynucleotide by homologous recombination with an exogenous template polynucleotide, wherein said repair results in a mutation comprising an insertion, deletion, or substitution of one or more nucleotides of said target polynucleotide. In some embodiments, said mutation results in one or more amino acid changes in a protein expression from a gene comprising the target sequence.

[0020] In one aspect, the invention provides a method for developing a biologically active agent that modulates a cell signaling event associated with a disease gene. In some embodiments, a disease gene is any gene associated an increase in the risk of having or developing a disease. In some embodiments, the method comprises (a) contacting a test compound with a model cell of any one of the described embodiments; and (b) detecting a change in a readout that is indicative of a reduction or an augmentation of a cell signaling event associated with said mutation in said disease gene, thereby developing said biologically active agent that modulates said cell signaling event associated with said disease gene.

[0021] In one aspect, the invention provides a recombinant polynucleotide comprising a guide sequence upstream of a

tracr mate sequence, wherein the guide sequence when expressed directs sequence-specific binding of a CRISPR complex to a corresponding target sequence present in a eukaryotic cell. In some embodiments, the target sequence is a viral sequence present in a eukaryotic cell. In some embodiments, the target sequence is a proto-oncogene or an oncogene.

[0022] In one aspect the invention provides for a method of selecting one or more prokaryotic cell(s) by introducing one or more mutations in a gene in the one or more prokaryotic cell (s), the method comprising: introducing one or more vectors into the prokaryotic cell (s), wherein the one or more vectors drive expression of one or more of: a CRISPR enzyme, a guide sequence linked to a tracr mate sequence, a tracr sequence, and an editing template; wherein the editing template comprises the one or more mutations that abolish CRISPR enzyme cleavage; allowing homologous recombination of the editing template with the target polynucleotide in the cell(s) to be selected; allowing a CRISPR complex to bind to a target polynucleotide to effect cleavage of the target polynucleotide within said gene, wherein the CRISPR complex comprises the CRISPR enzyme complexed with (1) the guide sequence that is hybridized to the target sequence within the target polynucleotide, and (2) the tracr mate sequence that is hybridized to the tracr sequence, wherein binding of the CRISPR complex to the target polynucleotide induces cell death, thereby allowing one or more prokaryotic cell(s) in which one or more mutations have been introduced to be selected. In a preferred embodiment, the CRISPR enzyme is Cas9. In another aspect of the invention the cell to be selected may be a eukaryotic cell. Aspects of the invention allow for selection of specific cells without requiring a selection marker or a two-step process that may include a counter-selection system.

[0023] Accordingly, it is an object of the invention not to encompass within the invention any previously known product, process of making the product, or method of using the product such that Applicants reserve the right and hereby disclose a disclaimer of any previously known product, process, or method. It is further noted that the invention does not intend to encompass within the scope of the invention any product, process, or making of the product or method of using the product, which does not meet the written description and enablement requirements of the USPTO (35 U.S.C. § 112, first paragraph) or the EPO (Article 83 of the EPC), such that Applicants reserve the right and hereby disclose a disclaimer of any previously described product, process of making the product, or method of using the product.

[0024] It is noted that in this disclosure and particularly in the claims and/or paragraphs, terms such as “comprises”, “comprising”, “comprising” and the like can have the meaning attributed to it in U.S. patent law; e.g., they can mean “includes”, “included”, “including”, and the like; and that terms such as “consisting essentially of” and “consists essentially of” have the meaning ascribed to them in U.S. patent law, e.g., they allow for elements not explicitly recited, but exclude elements that are found in the prior art or that affect a basic or novel characteristic of the invention. These and other embodiments are disclosed or are obvious from and encompassed by, the following Detailed Description.

BRIEF DESCRIPTION OF THE DRAWINGS

[0025] The novel features of the invention are set forth with particularity in the appended claims. A better understanding of the features and advantages of the present invention will be obtained by reference to the following detailed description that sets forth illustrative embodiments, in which the principles of the invention are utilized, and the accompanying drawings of which:

[0026] FIG. 1 shows a schematic model of the CRISPR system. The Cas9 nuclease from *Streptococcus pyogenes* (yellow) is targeted to genomic DNA by a synthetic guide RNA (sgRNA) consisting of a 20-nt guide sequence (blue) and a scaffold (red). The guide sequence base-pairs with the DNA target (blue), directly upstream of a requisite 5'-NGG protospacer adjacent motif (PAM; magenta), and Cas9 mediates a double-stranded break (DSB) ~3 bp upstream of the PAM (red triangle).

[0027] FIGS. 2A-2F show an exemplary CRISPR system, a possible mechanism of action, an example adaptation for expression in eukaryotic cells, and results of tests assessing nuclear localization and CRISPR activity. FIG. 2C discloses SEQ ID NOS 279-280, respectively, in order of appearance. FIG. 2E discloses SEQ ID NOS 281-283, respectively, in order of appearance. FIG. 2F discloses SEQ ID NOS 284-288, respectively, in order of appearance.

[0028] FIG. 3A-3C shows an exemplary expression cassette for expression of CRISPR system elements in eukaryotic cells, predicted structures of example guide sequences, and CRISPR system activity as measured in eukaryotic and prokaryotic cells (SEQ ID NOS 289-298, respectively, in order of appearance).

[0029] FIGS. 4A-4D show results of an evaluation of SpCas9 specificity for an example target. FIG. 4A discloses SEQ ID NOS 299, 282 and 300-310, respectively, in order of appearance. FIG. 4C discloses SEQ ID NO: 299.

[0030] FIGS. 5A-5G show an exemplary vector system and results for its use in directing homologous recombination in eukaryotic cells. FIG. 5E discloses SEQ ID NO: 311. FIG. 5F discloses SEQ ID NOS 312-313, respectively, in order of appearance. FIG. 5G discloses SEQ ID NOS 314-318, respectively, in order of appearance.

[0031] FIG. 6 provides a table of protospacer sequences (SEQ ID NOS 33, 32, 31, 322-327, 35, 34 and 330-334, respectively, in order of appearance) and summarizes modification efficiency results for protospacer targets designed based on exemplary *S. pyogenes* and *S. thermophilus* CRISPR systems with corresponding PAMs against loci in human and mouse genomes. Cells were transfected with Cas9 and either pre-crRNA/tracrRNA or chimeric RNA, and analyzed 72 hours after transfection. Percent indels are calculated based on Surveyor assay results from indicated cell lines (N=3 for all protospacer targets, errors are S.E.M., N.D. indicates not detectable using the Surveyor assay, and N.T. indicates not tested in this study).

[0032] FIGS. 7A-7C show a comparison of different tracrRNA transcripts for Cas9-mediated gene targeting. FIG. 7A discloses SEQ ID NOS 335-336, respectively, in order of appearance.

[0033] FIG. 8 shows a schematic of a surveyor nuclease assay for detection of double strand break-induced micro-insertions and -deletions.

[0034] FIGS. 9A-9B show exemplary bicistronic expression vectors for expression of CRISPR system elements in eukaryotic cells. FIG. 9A discloses SEQ ID NOS 337-339,

respectively, in order of appearance. FIG. 9B discloses SEQ ID NOS 340-342, respectively, in order of appearance.

[0035] FIG. 10A-10D shows a bacterial plasmid transformation interference assay, expression cassettes and plasmids used therein, and transformation efficiencies of cells used therein. FIG. 10A discloses SEQ ID NOS 343-345, respectively, in order of appearance.

[0036] FIGS. 11A-11C show histograms of distances between adjacent *S. pyogenes* SF370 locus 1 PAM (NGG) (FIG. 10A) and *S. thermophilus* LMD9 locus 2 PAM (NNA-GAAW) (FIG. 10B) in the human genome; and distances for each PAM by chromosome (Chr) (FIG. 10C).

[0037] FIGS. 12A-12C show an exemplary CRISPR system, an example adaptation for expression in eukaryotic cells, and results of tests assessing CRISPR activity. FIG. 12B discloses SEQ ID NOS 346-347, respectively, in order of appearance. FIG. 12C discloses SEQ ID NO: 348.

[0038] FIGS. 13A-13C show exemplary manipulations of a CRISPR system for targeting of genomic loci in mammalian cells. FIG. 13A discloses SEQ ID NO: 349. FIG. 13B discloses SEQ ID NOS 350-352, respectively, in order of appearance.

[0039] FIGS. 14A-14B show the results of a Northern blot analysis of crRNA processing in mammalian cells. FIG. 14A discloses SEQ ID NO: 353.

[0040] FIG. 15A-15B shows an exemplary selection of protospacers in the human PVALB and mouse Th loci. FIG. 15A discloses SEQ ID NO: 354. FIG. 15B discloses SEQ ID NO: 355.

[0041] FIG. 16 shows example protospacer and corresponding PAM sequence targets of the *S. thermophilus* CRISPR system in the human EMX1 locus (SEQ ID NO: 348).

[0042] FIG. 17 provides a table of sequences for primers and probes (SEQ ID NOS 36-39 and 356-363, respectively, in order of appearance) used for Surveyor, RFLP, genomic sequencing, and Northern blot assays.

[0043] FIGS. 18A-18C show exemplary manipulation of a CRISPR system with chimeric RNAs and results of SURVEYOR assays for system activity in eukaryotic cells. FIG. 18A discloses SEQ ID NO: 364, respectively, in order of appearance.

[0044] FIGS. 19A-19B show a graphical representation of the results of SURVEYOR assays for CRISPR system activity in eukaryotic cells (SEQ ID NOS 365-443, respectively, in order of appearance).

[0045] FIG. 20 shows an exemplary visualization of some *S. pyogenes* Cas9 target sites in the human genome using the UCSC genome browser.

[0046] FIG. 21 shows predicted secondary structures for exemplary chimeric RNAs comprising a guide sequence, tracr mate sequence, and tracr sequence (SEQ ID NOS 444-463, respectively, in order of appearance).

[0047] FIG. 22 shows exemplary bicistronic expression vectors for expression of CRISPR system elements in eukaryotic cells (SEQ ID NOS 464 and 341-342, respectively, in order of appearance).

[0048] FIG. 23A-23B shows that Cas9 nuclease activity against endogenous targets may be exploited for genome editing. (a) Concept of genome editing using the CRISPR system. The CRISPR targeting construct directed cleavage of a chromosomal locus and was co-transformed with an editing template that recombined with the target to prevent cleavage. Kanamycin-resistant transformants that survived

CRISPR attack contained modifications introduced by the editing template. tracr, trans-activating CRISPR RNA; aphA-3, kanamycin resistance gene. (b) Transformation of crR6M DNA in R6^{8232.5} cells with no editing template, the R6 wild-type srtA or the R6370.1 editing templates. Recombination of either R6 srtA or R6^{370.1} prevented cleavage by Cas9. Transformation efficiency was calculated as colony forming units (cfu) per μg of crR6M DNA; the mean values with standard deviations from at least three independent experiments are shown. PCR analysis was performed on 8 clones in each transformation. "Un." indicates the unedited srtA locus of strain R6^{8232.5}; "Ed." shows the editing template. R6^{8232.5} and R6^{370.1} targets are distinguished by restriction with EaeI.

[0049] FIG. 24A-24C shows analysis of PAM and seed sequences that eliminate Cas9 cleavage. (a) PCR products with randomized PAM sequences or randomized seed sequences were transformed in crR6 cells (SEQ ID NOS 465-469, respectively, in order of appearance). These cells expressed Cas9 loaded with a crRNA that targeted a chromosomal region of R6^{8232.5} cells (highlighted in pink) that is absent from the R6 genome. More than 2×10^5 chloramphenicol-resistant transformants, carrying inactive PAM or seed sequences, were combined for amplification and deep sequencing of the target region. (b) Relative proportion of number of reads after transformation of the random PAM constructs in crR6 cells (compared to number of reads in R6 transformants). The relative abundance for each 3-nucleotide PAM sequence is shown. Severely underrepresented sequences (NGG) are shown in red; partially underrepresented one in orange (NAG) (c) Relative proportion of number of reads after transformation of the random seed sequence constructs in crR6 cells (compared to number of reads in R6 transformants). The relative abundance of each nucleotide for each position of the first 20 nucleotides of the protospacer sequence is shown (SEQ ID NO: 470). High abundance indicates lack of cleavage by Cas9, i.e. a CRISPR inactivating mutation. The grey line shows the level of the WT sequence. The dotted line represents the level above which a mutation significantly disrupts cleavage (See section "Analysis of deep sequencing data" in Example 5)

[0050] FIG. 25A-25F shows introduction of single and multiple mutations using the CRISPR system in *S. pneumoniae*. (a) Nucleotide and amino acid sequences of the wild-type and edited (green nucleotides; underlined amino acid residues) bgaA. The protospacer, PAM and restriction sites are shown (SEQ ID NOS 471-475 and 472, respectively, in order of appearance). (b) Transformation efficiency of cells transformed with targeting constructs in the presence of an editing template or control. (c) PCR analysis for 8 transformants of each editing experiment followed by digestion with BtgZI (R→A) and TseI (NE→AA). Deletion of bgaA was revealed as a smaller PCR product. (d) Miller assay to measure the β -galactosidase activity of WT and edited strains. (e) For a single-step, double deletion the targeting construct contained two spacers (in this case matching srtA and bgaA) and was co-transformed with two different editing templates (f) PCR analysis for 8 transformants to detect deletions in srtA and bgaA loci. 6/8 transformants contained deletions of both genes.

[0051] FIG. 26A-26D provides mechanisms underlying editing using the CRISPR system. (a) A stop codon was introduced in the erythromycin resistance gene ermAM to generate strain JEN53. The wild-type sequence can be

restored by targeting the stop codon with the CRISPR::ermAM (stop) construct, and using the ermAM wild-type sequence as an editing template. (b) Mutant and wild-type ermAM sequences (SEQ ID NOS 476-479, respectively, in order of appearance). (c) Fraction of erythromycin-resistant (erm^R) cfu calculated from total or kanamycin-resistant (kan^R) cfu. (d) Fraction of total cells that acquire both the CRISPR construct and the editing template. Co-transformation of the CRISPR targeting construct produced more transformants (t-test, $p=0.011$). In all cases the values show the mean \pm s.d. for three independent experiments.

[0052] FIG. 27A-27D illustrates genome editing with the CRISPR system in *E. coli*. (a) A kanamycin-resistant plasmid carrying the CRISPR array (pCRISPR) targeting the gene to edit may be transformed in the HME63 recombinering strain containing a chloramphenicol-resistant plasmid harboring cas9 and tracr (pCas9), together with an oligonucleotide specifying the mutation. (b) A K42T mutation conferring streptomycin resistance was introduced in the rpsL gene (SEQ ID NOS 480-483, respectively, in order of appearance) (c) Fraction of streptomycin-resistant ($strep^R$) cfu calculated from total or kanamycin-resistant (kan^R) cfu. (d) Fraction of total cells that acquire both the pCRISPR plasmid and the editing oligonucleotide. Co-transformation of the pCRISPR targeting plasmid produced more transformants (t-test, $p=0.004$). In all cases the values showed the mean \pm s.d. for three independent experiments.

[0053] FIG. 28A-28B illustrates the transformation of crR6 genomic DNA leads to editing of the targeted locus (a) The IS1167 element of *S. pneumoniae* R6 was replaced by the CRISPR01 locus of *S. pyogenes* SF370 to generate crR6 strain. This locus encodes for the Cas9 nuclease, a CRISPR array with six spacers, the tracrRNA that is required for crRNA biogenesis and Cas1, Cas2 and Csn2, proteins not necessary for targeting. Strain crR6M contains a minimal functional CRISPR system without cas1, cas2 and csn2. The aphA-3 gene encodes kanamycin resistance. Protospacers from the streptococcal bacteriophages ϕ 8232.5 and ϕ 370.1 were fused to a chloramphenicol resistance gene (cat) and integrated in the srtA gene of strain R6 to generate strains R68232.5 and R6370.1. (b) Left panel: Transformation of crR6 and crR6M genomic DNA in R6^{8232.5} and R6^{370.1}. As a control of cell competence a streptomycin resistant gene was also transformed. Right panel: PCR analysis of 8 R6^{8232.5} transformants with crR6 genomic DNA. Primers that amplify the srtA locus were used for PCR. 7/8 genotyped colonies replaced the R68232.5 srtA locus by the WT locus from the crR6 genomic DNA.

[0054] FIG. 29A-29F provides chromatograms of DNA sequences of edited cells obtained in this study. In all cases the wild-type and mutant protospacer and PAM sequences (or their reverse complement) are indicated. When relevant, the amino acid sequence encoded by the protospacer is provided. For each editing experiment, all strains for which PCR and restriction analysis corroborated the introduction of the desired modification were sequenced. A representative chromatogram is shown. (a) Chromatogram for the introduction of a PAM mutation into the R6^{8232.5} target (FIG. 23d) (SEQ ID NOS 484-485, respectively, in order of appearance). (b) Chromatograms for the introduction of the R>A and NE>AA mutations into 3-galactosidase (bgaA) (FIG. 25c) (SEQ ID NOS 471-475 and 472, respectively, in order of appearance). (c) Chromatogram for the introduction of a 6664 bp deletion within bgaA ORF (FIGS. 25c and 25f).

The dotted line indicates the limits of the deletion (SEQ ID NOS 486-488, respectively, in order of appearance). (d) Chromatogram for the introduction of a 729 bp deletion within srtA ORF (FIG. 25f). The dotted line indicates the limits of the deletion (SEQ ID NOS 489-491, respectively, in order of appearance). (e) Chromatograms for the generation of a premature stop codon within ermAM (FIG. 33) (SEQ ID NOS 492-495, respectively, in order of appearance). (f) rpsL editing in *E. coli* (FIG. 27) (SEQ ID NOS 480-483, respectively, in order of appearance).

[0055] FIG. 30A-30C illustrates CRISPR immunity against random *S. pneumoniae* targets containing different PAMs. (a) Position of the 10 random targets on the *S. pneumoniae* R6 genome. The chosen targets have different PAMs and are on both strands. (b) Spacers corresponding to the targets were cloned in a minimal CRISPR array on plasmid pLZ12 and transformed into strain crR6Rc, which supplies the processing and targeting machinery in trans. (c) Transformation efficiency of the different plasmids in strain R6 and crR6Rc. No colonies were recovered for the transformation of pDB99-108 (T1-T10) in crR6Rc. The dashed line represents limit of detection of the assay.

[0056] FIG. 31 provides a general scheme for targeted genome editing. To facilitate targeted genome editing, crR6M was further engineered to contain tracrRNA, Cas9 and only one repeat of the CRISPR array followed by kanamycin resistance marker (aphA-3), generating strain crR6Rk. DNA from this strain is used as a template for PCR with primers designed to introduce a new spacer (green box designated with N). The left and right PCRs are assembled using the Gibson method to create the targeting construct. Both the targeting and editing constructs are then transformed into strain crR6Rc, which is a strain equivalent to crR6Rk but has the kanamycin resistance marker replaced by a chloramphenicol resistance marker (cat). About 90% of the kanamycin-resistant transformants contain the desired mutation.

[0057] FIG. 32 illustrates the distribution of distances between PAMs. NGG and CCN that are considered to be valid PAMs. Data is shown for the *S. pneumoniae* R6 genome as well as for a random sequence of the same length and with the same GC-content (39.7%). The dotted line represents the average distance (12) between PAMs in the R6 genome.

[0058] FIG. 33A-33D illustrates CRISPR-mediated editing of the ermAM locus using genomic DNA as targeting construct. To use genomic DNA as targeting construct it is necessary to avoid CRISPR autoimmunity, and therefore a spacer against a sequence not present in the chromosome must be used (in this case the ermAM erythromycin resistance gene). (a) Nucleotide and amino acid sequences of the wild-type and mutated (red letters) ermAM gene. The protospacer and PAM sequences are shown (SEQ ID NOS 492-495, respectively, in order of appearance). (b) A schematic for CRISPR-mediated editing of the ermAM locus using genomic DNA. A construct carrying an ermAM-targeting spacer (blue box) is made by PCR and Gibson assembly, and transformed into strain crR6Rc, generating strain JEN37. The genomic DNA of JEN37 was then used as a targeting construct, and was co-transformed with the editing template into JEN38, a strain in which the srtA gene was replaced by a wild-type copy of ermAM. Kanamycin-resistant transformants contain the edited genotype (JEN43). (c) Number of kanamycin-resistant cells obtained after co-

transformation of targeting and editing or control templates. In the presence of the control template 5.4×10^3 cfu/ml were obtained, and 4.3×10^5 cfu/ml when the editing template was used. This difference indicates an editing efficiency of about 99% [$(4.3 \times 10^5 - 5.4 \times 10^3) / 4.3 \times 10^5$]. (d) To check for the presence of edited cells seven kanamycin-resistant clones and JEN38 were streaked on agar plates with (erm+) or without (erm-) erythromycin. Only the positive control displayed resistance to erythromycin. The ermAM mut genotype of one of these transformants was also verified by DNA sequencing (FIG. 29e).

[0059] FIG. 34A-34D illustrates sequential introduction of mutations by CRISPR-mediated genome editing. (a) A schematic for sequential introduction of mutations by CRISPR-mediated genome editing. First, R6 is engineered to generate crR6Rk. crR6Rk is co-transformed with a *srtA*-targeting construct fused to cat for chloramphenicol selection of edited cells, along with an editing construct for a Δ *srtA* in-frame deletion. Strain crR6 Δ *srtA* is generated by selection on chloramphenicol. Subsequently, the Δ *srtA* strain is co-transformed with a *bgaA*-targeting construct fused to *aphA-3* for kanamycin selection of edited cells, and an editing construct containing a Δ *bgaA* in-frame deletion. Finally, the engineered CRISPR locus can be erased from the chromosome by first co-transforming R6 DNA containing the wild-type IS1167 locus and a plasmid carrying a *bgaA* protospacer (pDB97), and selection on spectinomycin. (b) PCR analysis for 8 chloramphenicol (Cam)-resistant transformants to detect the deletion in the *srtA* locus. (c) 3-galactosidase activity as measured by Miller assay. In *S. pneumoniae*, this enzyme is anchored to the cell wall by sortase A. Deletion of the *srtA* gene results in the release of 3-galactosidase into the supernatant. Δ *bgaA* mutants show no activity. (d) PCR analysis for 8 spectinomycin (Spec)-resistant transformants to detect the replacement of the CRISPR locus by wild-type IS1167.

[0060] FIG. 35A-35C illustrates the background mutation frequency of CRISPR in *S. pneumoniae*. (a) Transformation of the CRISPR:: \emptyset or CRISPR::erm(stop) targeting constructs in JEN53, with or without the ermAM editing template. The difference in kan^R CFU between CRISPR:: \emptyset and CRISPR::erm(stop) indicates that Cas9 cleavage kills non-edited cells. Mutants that escape CRISPR interference in the absence of editing template are observed at a frequency of 3×10^{-3} . (b) PCR analysis of the CRISPR locus of escapers shows that 7/8 have a spacer deletion. (c) Escaper #2 carries a point mutation in *cas9* (SEQ ID NOS 496-499, respectively, in order of appearance).

[0061] FIG. 36 illustrates that the essential elements of the *S. pyogenes* CRISPR locus 1 are reconstituted in *E. coli* using pCas9. The plasmid contained tracrRNA, Cas9, as well as a leader sequence driving the crRNA array. The pCRISPR plasmids contained the leader and the array only. Spacers may be inserted into the crRNA array between BsaI sites using annealed oligonucleotides (SEQ ID NOS 343, 500 and 127, respectively, in order of appearance). Oligonucleotide design is shown at bottom. pCas9 carried chloramphenicol resistance (CmR) and is based on the low-copy pACYC184 plasmid backbone. pCRISPR is based on the high-copy number pZE21 plasmid. Two plasmids were required because a pCRISPR plasmid containing a spacer targeting the *E. coli* chromosome may not be constructed using this organism as a cloning host if Cas9 is also present (it will kill the host).

[0062] FIG. 37 illustrates CRISPR-directed editing in *E. coli* MG1655. An oligonucleotide (W542) carrying a point mutation that both confers streptomycin resistance and abolishes CRISPR immunity, together with a plasmid targeting *rpsL* (pCRISPR::*rpsL*) or a control plasmid (pCRISPR:: \emptyset) were co-transformed into wild-type *E. coli* strain MG1655 containing pCas9. Transformants were selected on media containing either streptomycin or kanamycin. Dashed line indicates limit of detection of the transformation assay.

[0063] FIG. 38A-38B illustrates the background mutation frequency of CRISPR in *E. coli* HME63. (a) Transformation of the pCRISPR:: \emptyset or pCRISPR::*rpsL* plasmids into HME63 competent cells. Mutants that escape CRISPR interference were observed at a frequency of 2.6×10^{-4} . (b) Amplification of the CRISPR array of escapers showed that 8/8 have deleted the spacer.

[0064] FIGS. 39A-39D show a circular depiction of the phylogenetic analysis revealing five families of Cas9s, including three groups of large Cas9s (~1400 amino acids) and two of small Cas9s (~1100 amino acids).

[0065] FIGS. 40A-40F show the linear depiction of the phylogenetic analysis revealing five families of Cas9s, including three groups of large Cas9s (~1400 amino acids) and two of small Cas9s (~1100 amino acids).

[0066] FIG. 41A-41M shows sequences where the mutation points are located within the SpCas9 gene (SEQ ID NOS 501-502, respectively, in order of appearance).

[0067] FIG. 42 shows a schematic construct in which the transcriptional activation domain (VP64) is fused to Cas9 with two mutations in the catalytic domains (D10 and H840).

[0068] FIG. 43A-43D shows genome editing via homologous recombination. (a) Schematic of SpCas9 nickase, with D10A mutation in the RuvC I catalytic domain. (b) Schematic representing homologous recombination (HR) at the human EMX1 locus using either sense or antisense single stranded oligonucleotides as repair templates. Red arrow above indicates sgrRNA cleavage site; PCR primers for genotyping (Tables J and K) are indicated as arrows in right panel. (c) Sequence of region modified by HR. d, SURVEYOR assay for wildtype (wt) and nickase (D10A) SpCas9-mediated indels at the EAMX target 1 locus (n=3) (SEQ ID NOS 503-505, 503, 506 and 505, respectively, in order of appearance). Arrows indicate positions of expected fragment sizes.

[0069] FIGS. 44A-44B show single vector designs for SpCas9. FIG. 44A discloses SEQ ID NOS 320-321 and 328, respectively, in order of appearance. FIG. 44B discloses SEQ ID NO: 329.

[0070] FIG. 45 shows quantification of cleavage of NLS-Csn1 constructs NLS-Csn1, Csn1, Csn1-NLS, NLS-Csn1-NLS, NLS-Csn1-GFP-NLS and UnTFN.

[0071] FIG. 46 shows index frequency of NLS-Cas9, Cas9, Cas9-NLS and NLS-Cas9-NLS.

[0072] FIG. 47 shows a gel demonstrating that SpCas9 with nickase mutations (individually) do not induce double strand breaks.

[0073] FIG. 48A-48B shows a design of the oligo DNA used as Homologous Recombination (HR) template in this experiment and a comparison of HR efficiency induced by different combinations of Cas9 protein and HR template.

[0074] FIG. 49A shows the Conditional Cas9, Rosa26 targeting vector map.

[0075] FIG. 49B shows the Constitutive Cas9, Rosa26 targeting vector map.

[0076] FIG. 50A-50H show the sequences of each element present in the vector maps of FIGS. 49A-B (SEQ ID NOS 507-516, respectively, in order of appearance).

[0077] FIG. 51 shows a schematic of the important elements in the Constitutive and Conditional Cas9 constructs.

[0078] FIG. 52 shows the functional validation of the expression of Constitutive and Conditional Cas9 constructs.

[0079] FIG. 53 shows the validation of Cas9 nuclease activity by Surveyor.

[0080] FIG. 54 shows the quantification of Cas9 nuclease activity.

[0081] FIG. 55 shows construct design and homologous recombination (HR) strategy.

[0082] FIG. 56 shows the genomic PCR genotyping results for the constitutive (Right) and conditional (Left) constructs at two different gel exposure times (top row for 3 min and bottom row for 1 min).

[0083] FIG. 57 shows Cas9 activation in mESCs.

[0084] FIG. 58 shows a schematic of the strategy used to mediate gene knockout via NHEJ using a nickase version of Cas9 along with two guide RNAs.

[0085] FIG. 59 shows how DNA double-strand break (DSB) repair promotes gene editing. In the error-prone non-homologous end joining (NHEJ) pathway, the ends of a DSB are processed by endogenous DNA repair machineries and rejoined together, which can result in random insertion/deletion (indel) mutations at the site of junction. Indel mutations occurring within the coding region of a gene can result in frame-shift and a premature stop codon, leading to gene knockout. Alternatively, a repair template in the form of a plasmid or single-stranded oligodeoxynucleotides (ssODN) can be supplied to leverage the homology-directed repair (HDR) pathway, which allows high fidelity and precise editing.

[0086] FIG. 60 shows the timeline and overview of experiments. Steps for reagent design, construction, validation, and cell line expansion. Custom sgRNAs (light blue bars) for each target, as well as genotyping primers, are designed in silico via our online design tool (available at the website genome-engineering.org/tools). sgRNA expression vectors are then cloned into a plasmid containing Cas9 (PX330) and verified via DNA sequencing. Completed plasmids (pCRISPRs), and optional repair templates for facilitating homology directed repair, are then transfected into cells and assayed for ability to mediate targeted cleavage. Finally, transfected cells can be clonally expanded to derive isogenic cell lines with defined mutations.

[0087] FIG. 61A-61C shows Target selection and reagent preparation. (a) For *S. pyogenes* Cas9, 20-bp targets (highlighted in blue) must be followed by 5'-NGG, which can occur in either strand on genomic DNA. We recommend using the online tool described in this protocol in aiding target selection (www.genome-engineering.org/tools). (b) Schematic for co-transfection of Cas9 expression plasmid (PX165) and PCR-amplified U6-driven sgRNA expression cassette. Using a U6 promoter-containing PCR template and a fixed forward primer (U6 Fwd), sgRNA-encoding DNA can be appended onto the U6 reverse primer (U6 Rev) and synthesized as an extended DNA oligo (Ultrasmer oligos from IDT). Note the guide sequence (blue N's) in U6 Rev is the reverse complement of the 5'-NGG flanking target sequence (SEQ ID NOS 517 and 517-519, respectively, in

order of appearance). (c) Schematic for scarless cloning of the guide sequence oligos into a plasmid containing Cas9 and sgRNA scaffold (PX330). The guide oligos (blue N's) contain overhangs for ligation into the pair of BbsI sites on PX330, with the top and bottom strand orientations matching those of the genomic target (i.e. top oligo is the 20-bp sequence preceding 5'-NGG in genomic DNA). Digestion of PX330 with BbsI allows the replacement of the Type II restriction sites (blue outline) with direct insertion of annealed oligos. It is worth noting that an extra G was placed before the first base of the guide sequence. Applicants have found that an extra G in front of the guide sequence does not adversely affect targeting efficiency. In cases when the 20-nt guide sequence of choice does not begin with guanine, the extra guanine will ensure the sgRNA is efficiently transcribed by the U6 promoter, which prefers a guanine in the first base of the transcript (SEQ ID NOS 320-321 and 328, respectively, in order of appearance).

[0088] FIG. 62A-62D shows the anticipated results for multiplex NHEJ. (a) Schematic of the SURVEYOR assay used to determine indel percentage. First, genomic DNA from the heterogeneous population of Cas9-targeted cells is amplified by PCR. Amplicons are then reannealed slowly to generate heteroduplexes. The reannealed heteroduplexes are cleaved by SURVEYOR nuclease, whereas homoduplexes are left intact. Cas9-mediated cleavage efficiency (% indel) is calculated based on the fraction of cleaved DNA, as determined by integrated intensity of gel bands. (b) Two sgRNAs (orange and blue bars) are designed to target the human GRIN2B and DYRK1A loci. SURVEYOR gel shows modification at both loci in transfected cells. Colored arrows indicated expected fragment sizes for each locus. (c) A pair of sgRNAs (light blue and green bars) are designed to excise an exon (dark blue) in the human EMX1 locus. Target sequences and PAMs (red) are shown in respective colors, and sites of cleavage indicated by red triangle. Predicted junction is shown below. Individual clones isolated from cell populations transfected with sgRNA 3, 4, or both are assayed by PCR (OUT Fwd, OUT Rev), reflecting a deletion of ~270-bp. Representative clones with no modification (12/23), mono-allelic (10/23), and bi-allelic (1/23) modifications are shown. IN Fwd and IN Rev primers are used to screen for inversion events (FIG. 6d) (SEQ ID NOS 520-522, respectively, in order of appearance). (d) Quantification of clonal lines with EMX1 exon deletions. Two pairs of sgRNAs (3.1, 3.2 left-flanking sgRNAs; 4.1, 4.2, right flanking sgRNAs) are used to mediate deletions of variable sizes around one EMX1 exon. Transfected cells are clonally isolated and expanded for genotyping analysis for deletions and inversion events. Of the 105 clones are screened, 51 (49%) and 11 (10%) carrying heterozygous and homozygous deletions, respectively. Approximate deletion sizes are given since junctions may be variable.

[0089] FIG. 63A-63C shows the application of ssODNs and targeting vector to mediate HR with both wildtype and nickase mutant of Cas9 in HEK293FT and HUES9 cells with efficiencies ranging from 1.0-27%. FIG. 63B discloses SEQ ID NOS 503-505, 503, 506 and 505, respectively, in order of appearance.

[0090] FIG. 64 shows a schematic of a PCR-based method for rapid and efficient CRISPR targeting in mammalian cells. A plasmid containing the human RNA polymerase III promoter U6 is PCR-amplified using a U6-specific forward primer and a reverse primer carrying the reverse comple-

ment of part of the U6 promoter, the sgRNA(+85) scaffold with guide sequence, and 7 T nucleotides for transcriptional termination. The resulting PCR product is purified and co-delivered with a plasmid carrying Cas9 driven by the CBh promoter (SEQ ID NOS 517, 523, 518 and 524-525, respectively, in order of appearance).

[0091] FIG. 65 shows SURVEYOR Mutation Detection Kit from Transgenomics results for each gRNA and respective controls. A positive SURVEYOR result is one large band corresponding to the genomic PCR and two smaller bands that are the product of the SURVEYOR nuclease making a double-strand break at the site of a mutation. Each gRNA was validated in the mouse cell line, Neuro-N2a, by liposomal transient co-transfection with hSpCas9. 72 hours post-transfection genomic DNA was purified using Quick-Extract DNA from Epicentre. PCR was performed to amplify the locus of interest.

[0092] FIG. 66 shows Surveyor results for 38 live pups (lanes 1-38) 1 dead pup (lane 39) and 1 wild-type pup for comparison (lane 40). Pups 1-19 were injected with gRNA Chd8.2 and pups 20-38 were injected with gRNA Chd8.3. Of the 38 live pups, 13 were positive for a mutation. The one dead pup also had a mutation. There was no mutation detected in the wild-type sample. Genomic PCR sequencing was consistent with the SURVEYOR assay findings (SEQ ID NOS 526-528, respectively, in order of appearance).

[0093] FIG. 67 shows a design of different Cas9 NLS constructs. All Cas9 were the human-codon-optimized version of the Sp Cas9. NLS sequences are linked to the cas9 gene at either N-terminus or C-terminus. All Cas9 variants with different NLS designs were cloned into a backbone vector containing so it is driven by EF1 α promoter. On the same vector there is a chimeric RNA targeting human EMX1 locus driven by U6 promoter, together forming a two-component system.

[0094] FIG. 68 shows the efficiency of genomic cleavage induced by Cas9 variants bearing different NLS designs. The percentage indicate the portion of human EMX1 genomic DNA that were cleaved by each construct. All experiments are from 3 biological replicates. n=3, error indicates S.E.M.

[0095] FIG. 69A shows a design of the CRISPR-TF (Transcription Factor) with transcriptional activation activity. The chimeric RNA is expressed by U6 promoter, while a human-codon-optimized, double-mutant version of the Cas9 protein (hSpCas9m), operably linked to triple NLS and a VP64 functional domain is expressed by a EF1 α promoter. The double mutations, D10A and H840A, renders the cas9 protein unable to introduce any cleavage but maintained its capacity to bind to target DNA when guided by the chimeric RNA.

[0096] FIG. 69B shows transcriptional activation of the human SOX2 gene with CRISPR-TF system (Chimeric RNA and the Cas9-NLS-VP64 fusion protein). 293FT cells were transfected with plasmids bearing two components: (1) U6-driven different chimeric RNAs targeting 20-bp sequences within or around the human SOX2 genomic locus, and (2) EF1 α -driven hSpCas9m (double mutant)-NLS-VP64 fusion protein. 96 hours post transfection, 293FT cells were harvested and the level of activation is measured by the induction of mRNA expression using a qRT-PCR assay. All expression levels are normalized against the control group (grey bar), which represents results from cells transfected with the CRISPR-TF backbone plasmid without chimeric RNA. The qRT-PCR probes used for

detecting the SOX2 mRNA is Taqman Human Gene Expression Assay (Life Technologies). All experiments represents data from 3 biological replicates, n=3, error bars show s.e.m. **[0097]** FIG. 70 depicts NLS architecture optimization for SpCas9.

[0098] FIG. 71 shows a QQ plot for NGGNN sequences. **[0099]** FIG. 72 shows a histogram of the data density with fitted normal distribution (black line) and 0.99 quantile (dotted line).

[0100] FIG. 73A-73C shows RNA-guided repression of bgaA expression by dgRNA::cas9**. a. The Cas9 protein binds to the tracrRNA, and to the precursor CRISPR RNA which is processed by RNaseIII to form the crRNA. The crRNA directs binding of Cas9 to the bgaA promoter and represses transcription. b. The targets used to direct Cas9** to the bgaA promoter are represented (SEQ ID NO: 529). Putative -35, -10 as well as the bgaA start codon are in bold. c. Betagalactosidase activity as measure by Miller assay in the absence of targeting and for the four different targets.

[0101] FIG. 74A-74E shows characterization of Cas9** mediated repression. a. The gfpmut2 gene and its promoter, including the -35 and -10 signals are represented together with the position of the different target sites used the study. b. Relative fluorescence upon targeting of the coding strand. c. Relative fluorescence upon targeting of the non-coding strand. d. Northern blot with probes B477 and B478 on RNA extracted from T5, T10, B10 or a control strain without a target. e. Effect of an increased number of mutations in the 5' end of the crRNA of B1, T5 and B10.

[0102] The figures herein are for illustrative purposes only and are not necessarily drawn to scale.

DETAILED DESCRIPTION OF THE INVENTION

[0103] The terms “polynucleotide”, “nucleotide”, “nucleotide sequence”, “nucleic acid” and “oligonucleotide” are used interchangeably. They refer to a polymeric form of nucleotides of any length, either deoxyribonucleotides or ribonucleotides, or analogs thereof. Polynucleotides may have any three dimensional structure, and may perform any function, known or unknown. The following are non-limiting examples of polynucleotides: coding or non-coding regions of a gene or gene fragment, loci (locus) defined from linkage analysis, exons, introns, messenger RNA (mRNA), transfer RNA, ribosomal RNA, short interfering RNA (siRNA), short-hairpin RNA (shRNA), micro-RNA (miRNA), ribozymes, cDNA, recombinant polynucleotides, branched polynucleotides, plasmids, vectors, isolated DNA of any sequence, isolated RNA of any sequence, nucleic acid probes, and primers. A polynucleotide may comprise one or more modified nucleotides, such as methylated nucleotides and nucleotide analogs. If present, modifications to the nucleotide structure may be imparted before or after assembly of the polymer. The sequence of nucleotides may be interrupted by non-nucleotide components. A polynucleotide may be further modified after polymerization, such as by conjugation with a labeling component.

[0104] In aspects of the invention the terms “chimeric RNA”, “chimeric guide RNA”, “guide RNA”, “single guide RNA” and “synthetic guide RNA” are used interchangeably and refer to the polynucleotide sequence comprising the guide sequence, the tracr sequence and the tracr mate sequence. The term “guide sequence” refers to the about 20 bp sequence within the guide RNA that specifies the target

site and may be used interchangeably with the terms “guide” or “spacer”. The term “tracer sequence” may also be used interchangeably with the term “direct repeat(s)”.

[0105] As used herein the term “wild type” is a term of the art understood by skilled persons and means the typical form of an organism, strain, gene or characteristic as it occurs in nature as distinguished from mutant or variant forms.

[0106] As used herein the term “variant” should be taken to mean the exhibition of qualities that have a pattern that deviates from what occurs in nature.

[0107] The terms “non-naturally occurring” or “engineered” are used interchangeably and indicate the involvement of the hand of man. The terms, when referring to nucleic acid molecules or polypeptides mean that the nucleic acid molecule or the polypeptide is at least substantially free from at least one other component with which they are naturally associated in nature and as found in nature.

[0108] “Complementarity” refers to the ability of a nucleic acid to form hydrogen bond(s) with another nucleic acid sequence by either traditional Watson-Crick base pairing or other non-traditional types. A percent complementarity indicates the percentage of residues in a nucleic acid molecule which can form hydrogen bonds (e.g., Watson-Crick base pairing) with a second nucleic acid sequence (e.g., 5, 6, 7, 8, 9, 10 out of 10 being 50%, 60%, 70%, 80%, 90%, and 100% complementary). “Perfectly complementary” means that all the contiguous residues of a nucleic acid sequence will hydrogen bond with the same number of contiguous residues in a second nucleic acid sequence. “Substantially complementary” as used herein refers to a degree of complementarity that is at least 60%, 65%, 70%, 75%, 80%, 85%, 90%, 95%, 97%, 98%, 99%, or 100% over a region of 8, 9, 10, 11, 12, 13, 14, 15, 16, 17, 18, 19, 20, 21, 22, 23, 24, 25, 30, 35, 40, 45, 50, or more nucleotides, or refers to two nucleic acids that hybridize under stringent conditions.

[0109] As used herein, “stringent conditions” for hybridization refer to conditions under which a nucleic acid having complementarity to a target sequence predominantly hybridizes with the target sequence, and substantially does not hybridize to non-target sequences. Stringent conditions are generally sequence-dependent, and vary depending on a number of factors. In general, the longer the sequence, the higher the temperature at which the sequence specifically hybridizes to its target sequence. Non-limiting examples of stringent conditions are described in detail in Tijssen (1993), *Laboratory Techniques In Biochemistry And Molecular Biology-Hybridization With Nucleic Acid Probes Part I, Second Chapter “Overview of principles of hybridization and the strategy of nucleic acid probe assay”*, Elsevier, N.Y.

[0110] “Hybridization” refers to a reaction in which one or more polynucleotides react to form a complex that is stabilized via hydrogen bonding between the bases of the nucleotide residues. The hydrogen bonding may occur by Watson Crick base pairing, Hoogstein binding, or in any other sequence specific manner. The complex may comprise two strands forming a duplex structure, three or more strands forming a multi stranded complex, a single self hybridizing strand, or any combination of these. A hybridization reaction may constitute a step in a more extensive process, such as the initiation of PCR, or the cleavage of a polynucleotide by an enzyme. A sequence capable of hybridizing with a given sequence is referred to as the “complement” of the given sequence.

[0111] As used herein, “expression” refers to the process by which a polynucleotide is transcribed from a DNA template (such as into and mRNA or other RNA transcript) and/or the process by which a transcribed mRNA is subsequently translated into peptides, polypeptides, or proteins. Transcripts and encoded polypeptides may be collectively referred to as “gene product.” If the polynucleotide is derived from genomic DNA, expression may include splicing of the mRNA in a eukaryotic cell.

[0112] The terms “polypeptide”, “peptide” and “protein” are used interchangeably herein to refer to polymers of amino acids of any length. The polymer may be linear or branched, it may comprise modified amino acids, and it may be interrupted by non amino acids. The terms also encompass an amino acid polymer that has been modified; for example, disulfide bond formation, glycosylation, lipidation, acetylation, phosphorylation, or any other manipulation, such as conjugation with a labeling component. As used herein the term “amino acid” includes natural and/or unnatural or synthetic amino acids, including glycine and both the D or L optical isomers, and amino acid analogs and peptidomimetics.

[0113] The terms “subject,” “individual,” and “patient” are used interchangeably herein to refer to a vertebrate, preferably a mammal, more preferably a human. Mammals include, but are not limited to, murines, simians, humans, farm animals, sport animals, and pets. Tissues, cells and their progeny of a biological entity obtained in vivo or cultured in vitro are also encompassed.

[0114] The terms “therapeutic agent”, “therapeutic capable agent” or “treatment agent” are used interchangeably and refer to a molecule or compound that confers some beneficial effect upon administration to a subject. The beneficial effect includes enablement of diagnostic determinations; amelioration of a disease, symptom, disorder, or pathological condition; reducing or preventing the onset of a disease, symptom, disorder or condition; and generally counteracting a disease, symptom, disorder or pathological condition.

[0115] As used herein, “treatment” or “treating,” or “palliating” or “ameliorating” are used interchangeably. These terms refer to an approach for obtaining beneficial or desired results including but not limited to a therapeutic benefit and/or a prophylactic benefit. By therapeutic benefit is meant any therapeutically relevant improvement in or effect on one or more diseases, conditions, or symptoms under treatment. For prophylactic benefit, the compositions may be administered to a subject at risk of developing a particular disease, condition, or symptom, or to a subject reporting one or more of the physiological symptoms of a disease, even though the disease, condition, or symptom may not have yet been manifested.

[0116] The term “effective amount” or “therapeutically effective amount” refers to the amount of an agent that is sufficient to effect beneficial or desired results. The therapeutically effective amount may vary depending upon one or more of: the subject and disease condition being treated, the weight and age of the subject, the severity of the disease condition, the manner of administration and the like, which can readily be determined by one of ordinary skill in the art. The term also applies to a dose that will provide an image for detection by any one of the imaging methods described herein. The specific dose may vary depending on one or more of: the particular agent chosen, the dosing regimen to

be followed, whether it is administered in combination with other compounds, timing of administration, the tissue to be imaged, and the physical delivery system in which it is carried.

[0117] The practice of the present invention employs, unless otherwise indicated, conventional techniques of immunology, biochemistry, chemistry, molecular biology, microbiology, cell biology, genomics and recombinant DNA, which are within the skill of the art. See Sambrook, Fritsch and Maniatis, *MOLECULAR CLONING: A LABORATORY MANUAL*, 2nd edition (1989); *CURRENT PROTOCOLS IN MOLECULAR BIOLOGY* (F. M. Ausubel, et al. eds., (1987)); the series *METHODS IN ENZYMOLOGY* (Academic Press, Inc.): PCR 2: A PRACTICAL APPROACH (M. J. MacPherson, B. D. Hames and G. R. Taylor eds. (1995)), Harlow and Lane, eds. (1988) *ANTIBODIES, A LABORATORY MANUAL*, and *ANIMAL CELL CULTURE* (R. I. Freshney, ed. (1987)).

[0118] Several aspects of the invention relate to vector systems comprising one or more vectors, or vectors as such. Vectors can be designed for expression of CRISPR transcripts (e.g. nucleic acid transcripts, proteins, or enzymes) in prokaryotic or eukaryotic cells. For example, CRISPR transcripts can be expressed in bacterial cells such as *Escherichia coli*, insect cells (using baculovirus expression vectors), yeast cells, or mammalian cells. Suitable host cells are discussed further in Goeddel, *GENE EXPRESSION TECHNOLOGY: METHODS IN ENZYMOLOGY 185*, Academic Press, San Diego, Calif. (1990). Alternatively, the recombinant expression vector can be transcribed and translated in vitro, for example using T7 promoter regulatory sequences and T7 polymerase.

[0119] Vectors may be introduced and propagated in a prokaryote. In some embodiments, a prokaryote is used to amplify copies of a vector to be introduced into a eukaryotic cell or as an intermediate vector in the production of a vector to be introduced into a eukaryotic cell (e.g. amplifying a plasmid as part of a viral vector packaging system). In some embodiments, a prokaryote is used to amplify copies of a vector and express one or more nucleic acids, such as to provide a source of one or more proteins for delivery to a host cell or host organism. Expression of proteins in prokaryotes is most often carried out in *Escherichia coli* with vectors containing constitutive or inducible promoters directing the expression of either fusion or non-fusion proteins. Fusion vectors add a number of amino acids to a protein encoded therein, such as to the amino terminus of the recombinant protein. Such fusion vectors may serve one or more purposes, such as: (i) to increase expression of recombinant protein; (ii) to increase the solubility of the recombinant protein; and (iii) to aid in the purification of the recombinant protein by acting as a ligand in affinity purification. Often, in fusion expression vectors, a proteolytic cleavage site is introduced at the junction of the fusion moiety and the recombinant protein to enable separation of the recombinant protein from the fusion moiety subsequent to purification of the fusion protein. Such enzymes, and their cognate recognition sequences, include Factor Xa, thrombin and enterokinase. Example fusion expression vectors include pGEX (Pharmacia Biotech Inc; Smith and Johnson, 1988. *Gene* 67: 31-40), pMAL (New England Biolabs, Beverly, Mass.) and pRIT5 (Pharmacia, Piscataway, N.J.)

that fuse glutathione S-transferase (GST), maltose E binding protein, or protein A, respectively, to the target recombinant protein.

[0120] Examples of suitable inducible non-fusion *E. coli* expression vectors include pTrc (Amrann et al., (1988) *Gene* 69:301-315) and pET 11d (Studier et al., *GENE EXPRESSION TECHNOLOGY: METHODS IN ENZYMOLOGY 185*, Academic Press, San Diego, Calif. (1990) 60-89).

[0121] In some embodiments, a vector is a yeast expression vector. Examples of vectors for expression in yeast *Saccharomyces cerevisiae* include pYepSec1 (Baldari, et al., 1987. *EMBO J.* 6: 229-234), pMFa (Kuijan and Herskowitz, 1982. *Cell* 30: 933-943), pJRY88 (Schultz et al., 1987. *Gene* 54: 113-123), pYES2 (Invitrogen Corporation, San Diego, Calif.), and picZ (Invitrogen Corp, San Diego, Calif.).

[0122] In some embodiments, a vector drives protein expression in insect cells using baculovirus expression vectors. Baculovirus vectors available for expression of proteins in cultured insect cells (e.g., SF9 cells) include the pAc series (Smith, et al., 1983. *Mol. Cell. Biol.* 3: 2156-2165) and the pVL series (Lucklow and Summers, 1989. *Virology* 170: 31-39).

[0123] In some embodiments, a vector is capable of driving expression of one or more sequences in mammalian cells using a mammalian expression vector. Examples of mammalian expression vectors include pCDM8 (Seed, 1987. *Nature* 329: 840) and pMT2PC (Kaufman, et al., 1987. *EMBO J.* 6: 187-195). When used in mammalian cells, the expression vector's control functions are typically provided by one or more regulatory elements. For example, commonly used promoters are derived from polyoma, adenovirus 2, cytomegalovirus, simian virus 40, and others disclosed herein and known in the art. For other suitable expression systems for both prokaryotic and eukaryotic cells see, e.g., Chapters 16 and 17 of Sambrook, et al., *MOLECULAR CLONING: A LABORATORY MANUAL*, 2nd ed., Cold Spring Harbor Laboratory, Cold Spring Harbor Laboratory Press, Cold Spring Harbor, N.Y., 1989.

[0124] In some embodiments, the recombinant mammalian expression vector is capable of directing expression of the nucleic acid preferentially in a particular cell type (e.g., tissue-specific regulatory elements are used to express the nucleic acid). Tissue-specific regulatory elements are known in the art. Non-limiting examples of suitable tissue-specific promoters include the albumin promoter (liver-specific; Pinkert, et al., 1987. *Genes Dev.* 1: 268-277), lymphoid-specific promoters (Calame and Eaton, 1988. *Adv. Immunol.* 43: 235-275), in particular promoters of T cell receptors (Winoto and Baltimore, 1989. *EMBO J.* 8: 729-733) and immunoglobulins (Baneiji, et al., 1983. *Cell* 33: 729-740; Queen and Baltimore, 1983. *Cell* 33: 741-748), neuron-specific promoters (e.g., the neurofilament promoter; Byrne and Ruddle, 1989. *Proc. Natl. Acad. Sci. USA* 86: 5473-5477), pancreas-specific promoters (Edlund, et al., 1985. *Science* 230: 912-916), and mammary gland-specific promoters (e.g., milk whey promoter; U.S. Pat. No. 4,873,316 and European Application Publication No. 264,166). Developmentally-regulated promoters are also encompassed, e.g., the murine hox promoters (Kessel and Gruss, 1990. *Science* 249: 374-379) and the α -fetoprotein promoter (Campes and Tilghman, 1989. *Genes Dev.* 3: 537-546).

[0125] In some embodiments, a regulatory element is operably linked to one or more elements of a CRISPR system so as to drive expression of the one or more elements

of the CRISPR system. In general, CRISPRs (Clustered Regularly Interspaced Short Palindromic Repeats), also known as SPIDRs (Spacer Interspersed Direct Repeats), constitute a family of DNA loci that are usually specific to a particular bacterial species. The CRISPR locus comprises a distinct class of interspersed short sequence repeats (SSRs) that were recognized in *E. coli* (Ishino et al., *J. Bacteriol.*, 169:5429-5433 [1987]; and Nakata et al., *J. Bacteriol.*, 171:3553-3556 [1989]), and associated genes. Similar interspersed SSRs have been identified in *Haloferax mediterranei*, *Streptococcus pyogenes*, *Anabaena*, and *Mycobacterium tuberculosis* (See, Groenen et al., *Mol. Microbiol.*, 10:1057-1065 [1993]; Hoe et al., *Emerg. Infect. Dis.*, 5:254-263 [1999]; Masepohl et al., *Biochim. Biophys. Acta* 1307: 26-30 [1996]; and Mojica et al., *Mol. Microbiol.*, 17:85-93 [1995]). The CRISPR loci typically differ from other SSRs by the structure of the repeats, which have been termed short regularly spaced repeats (SRSRs) (Janssen et al., *OMICS J. Integ. Biol.*, 6:23-33 [2002]; and Mojica et al., *Mol. Microbiol.*, 36:244-246 [2000]). In general, the repeats are short elements that occur in clusters that are regularly spaced by unique intervening sequences with a substantially constant length (Mojica et al., [2000], supra). Although the repeat sequences are highly conserved between strains, the number of interspersed repeats and the sequences of the spacer regions typically differ from strain to strain (van Embden et al., *J. Bacteriol.*, 182:2393-2401 [2000]). CRISPR loci have been identified in more than 40 prokaryotes (See e.g., Jansen et al., *Mol. Microbiol.*, 43:1565-1575 [2002]; and Mojica et al., [2005]) including, but not limited to *Aeropyrum*, *Pyrobaculum*, *Sulfolobus*, *Archaeoglobus*, *Halocarcularia*, *Methanobacterium*, *Methanococcus*, *Methanosarcina*, *Methanopyrus*, *Pyrococcus*, *Picrophilus*, *Thermoplasma*, *Corynebacterium*, *Mycobacterium*, *Streptomyces*, *Aquifex*, *Porphyromonas*, *Chlorobium*, *Thermus*, *Bacillus*, *Listeria*, *Staphylococcus*, *Clostridium*, *Thermoanaerobacter*, *Mycoplasma*, *Fusobacterium*, *Azarcus*, *Chromobacterium*, *Neisseria*, *Nitrosomonas*, *Desulfovibrio*, *Geobacter*, *Mycococcus*, *Campylobacter*, *Wolinella*, *Acinetobacter*, *Erwinia*, *Escherichia*, *Legionella*, *Methylococcus*, *Pasteurella*, *Photobacterium*, *Salmonella*, *Xanthomonas*, *Yersinia*, *Treponema*, and *Thermotoga*.

[0126] In general, “CRISPR system” refers collectively to transcripts and other elements involved in the expression of or directing the activity of CRISPR-associated (“Cas”) genes, including sequences encoding a Cas gene, a tracr (trans-activating CRISPR) sequence (e.g. tracrRNA or an active partial tracrRNA), a tracr-mate sequence (encompassing a “direct repeat” and a tracrRNA-processed partial direct repeat in the context of an endogenous CRISPR system), a guide sequence (also referred to as a “spacer” in the context of an endogenous CRISPR system), or other sequences and transcripts from a CRISPR locus. In some embodiments, one or more elements of a CRISPR system is derived from a type I, type II, or type III CRISPR system. In some embodiments, one or more elements of a CRISPR system is derived from a particular organism comprising an endogenous CRISPR system, such as *Streptococcus pyogenes*. In general, a CRISPR system is characterized by elements that promote the formation of a CRISPR complex at the site of a target sequence (also referred to as a protospacer in the context of an endogenous CRISPR system). In the context of formation of a CRISPR complex, “target sequence” refers to a sequence to which a guide sequence is designed to have

complementarity, where hybridization between a target sequence and a guide sequence promotes the formation of a CRISPR complex. Full complementarity is not necessarily required, provided there is sufficient complementarity to cause hybridization and promote formation of a CRISPR complex. A target sequence may comprise any polynucleotide, such as DNA or RNA polynucleotides. In some embodiments, a target sequence is located in the nucleus or cytoplasm of a cell. In some embodiments, the target sequence may be within an organelle of a eukaryotic cell, for example, mitochondrion or chloroplast. A sequence or template that may be used for recombination into the targeted locus comprising the target sequences is referred to as an “editing template” or “editing polynucleotide” or “editing sequence”. In aspects of the invention, an exogenous template polynucleotide may be referred to as an editing template. In an aspect of the invention the recombination is homologous recombination.

[0127] Typically, in the context of an endogenous CRISPR system, formation of a CRISPR complex (comprising a guide sequence hybridized to a target sequence and complexed with one or more Cas proteins) results in cleavage of one or both strands in or near (e.g. within 1, 2, 3, 4, 5, 6, 7, 8, 9, 10, 20, 50, or more base pairs from) the target sequence. Without wishing to be bound by theory, the tracr sequence, which may comprise or consist of all or a portion of a wild-type tracr sequence (e.g. about or more than about 20, 26, 32, 45, 48, 54, 63, 67, 85, or more nucleotides of a wild-type tracr sequence), may also form part of a CRISPR complex, such as by hybridization along at least a portion of the tracr sequence to all or a portion of a tracr mate sequence that is operably linked to the guide sequence. In some embodiments, the tracr sequence has sufficient complementarity to a tracr mate sequence to hybridize and participate in formation of a CRISPR complex. As with the target sequence, it is believed that complete complementarity is not needed, provided there is sufficient to be functional. In some embodiments, the tracr sequence has at least 50%, 60%, 70%, 80%, 90%, 95% or 99% of sequence complementarity along the length of the tracr mate sequence when optimally aligned. In some embodiments, one or more vectors driving expression of one or more elements of a CRISPR system are introduced into a host cell such that expression of the elements of the CRISPR system direct formation of a CRISPR complex at one or more target sites. For example, a Cas enzyme, a guide sequence linked to a tracr-mate sequence, and a tracr sequence could each be operably linked to separate regulatory elements on separate vectors. Alternatively, two or more of the elements expressed from the same or different regulatory elements, may be combined in a single vector, with one or more additional vectors providing any components of the CRISPR system not included in the first vector. CRISPR system elements that are combined in a single vector may be arranged in any suitable orientation, such as one element located 5' with respect to (“upstream” of) or 3' with respect to (“downstream” of) a second element. The coding sequence of one element may be located on the same or opposite strand of the coding sequence of a second element, and oriented in the same or opposite direction. In some embodiments, a single promoter drives expression of a transcript encoding a CRISPR enzyme and one or more of the guide sequence, tracr mate sequence (optionally operably linked to the guide sequence), and a tracr sequence

embedded within one or more intron sequences (e.g. each in a different intron, two or more in at least one intron, or all in a single intron). In some embodiments, the CRISPR enzyme, guide sequence, tracr mate sequence, and tracr sequence are operably linked to and expressed from the same promoter.

[0128] In some embodiments, a vector comprises one or more insertion sites, such as a restriction endonuclease recognition sequence (also referred to as a “cloning site”). In some embodiments, one or more insertion sites (e.g. about or more than about 1, 2, 3, 4, 5, 6, 7, 8, 9, 10, or more insertion sites) are located upstream and/or downstream of one or more sequence elements of one or more vectors. In some embodiments, a vector comprises an insertion site upstream of a tracr mate sequence, and optionally downstream of a regulatory element operably linked to the tracr mate sequence, such that following insertion of a guide sequence into the insertion site and upon expression the guide sequence directs sequence-specific binding of a CRISPR complex to a target sequence in a eukaryotic cell. In some embodiments, a vector comprises two or more insertion sites, each insertion site being located between two tracr mate sequences so as to allow insertion of a guide sequence at each site. In such an arrangement, the two or more guide sequences may comprise two or more copies of a single guide sequence, two or more different guide sequences, or combinations of these. When multiple different guide sequences are used, a single expression construct may be used to target CRISPR activity to multiple different, corresponding target sequences within a cell. For example, a single vector may comprise about or more than about 1, 2, 3, 4, 5, 6, 7, 8, 9, 10, 15, 20, or more guide sequences. In some embodiments, about or more than about 1, 2, 3, 4, 5, 6, 7, 8, 9, 10, or more such guide-sequence-containing vectors may be provided, and optionally delivered to a cell.

[0129] In some embodiments, a vector comprises a regulatory element operably linked to an enzyme-coding sequence encoding a CRISPR enzyme, such as a Cas protein. Non-limiting examples of Cas proteins include Cas1, Cas1B, Cas2, Cas3, Cas4, Cas5, Cas6, Cas7, Cas8, Cas9 (also known as Csn1 and Csx12), Cas10, Csy1, Csy2, Csy3, Cse1, Cse2, Csc1, Csc2, Csa5, Csn2, Csm2, Csm3, Csm4, Csm5, Csm6, Cmr1, Cmr3, Cmr4, Cmr5, Cmr6, Csb1, Csb2, Csb3, Csx17, Csx14, Csx10, Csx16, CsaX, Csx3, Csx1, Csx15, Csf1, Csf2, Csf3, Csf4, homologs thereof, or modified versions thereof. These enzymes are known; for example, the amino acid sequence of *S. pyogenes* Cas9 protein may be found in the SwissProt database under accession number Q99ZW2. In some embodiments, the unmodified CRISPR enzyme has DNA cleavage activity, such as Cas9. In some embodiments the CRISPR enzyme is Cas9, and may be Cas9 from *S. pyogenes* or *S. pneumoniae*. In some embodiments, the CRISPR enzyme directs cleavage of one or both strands at the location of a target sequence, such as within the target sequence and/or within the complement of the target sequence. In some embodiments, the CRISPR enzyme directs cleavage of one or both strands within about 1, 2, 3, 4, 5, 6, 7, 8, 9, 10, 15, 20, 25, 50, 100, 200, 500, or more base pairs from the first or last nucleotide of a target sequence. In some embodiments, a vector encodes a CRISPR enzyme that is mutated to with respect to a corresponding wild-type enzyme such that the mutated CRISPR enzyme lacks the ability to cleave one or both strands of a target polynucleotide containing a target

sequence. For example, an aspartate-to-alanine substitution (D10A) in the RuvC I catalytic domain of Cas9 from *S. pyogenes* converts Cas9 from a nuclease that cleaves both strands to a nickase (cleaves a single strand). Other examples of mutations that render Cas9 a nickase include, without limitation, H840A, N854A, and N863A. In some embodiments, a Cas9 nickase may be used in combination with guide sequence(s), e.g., two guide sequences, which target respectively sense and antisense strands of the DNA target. This combination allows both strands to be nicked and used to induce NHEJ. Applicants have demonstrated (data not shown) the efficacy of two nickase targets (i.e., sgRNAs targeted at the same location but to different strands of DNA) in inducing mutagenic NHEJ. A single nickase (Cas9-D10A with a single sgRNA) is unable to induce NHEJ and create indels but Applicants have shown that double nickase (Cas9-D10A and two sgRNAs targeted to different strands at the same location) can do so in human embryonic stem cells (hESCs). The efficiency is about 50% of nuclease (i.e., regular Cas9 without D10 mutation) in hESCs.

[0130] As a further example, two or more catalytic domains of Cas9 (RuvC I, RuvC II, and RuvC III) may be mutated to produce a mutated Cas9 substantially lacking all DNA cleavage activity. In some embodiments, a D10A mutation is combined with one or more of H840A, N854A, or N863A mutations to produce a Cas9 enzyme substantially lacking all DNA cleavage activity. In some embodiments, a CRISPR enzyme is considered to substantially lack all DNA cleavage activity when the DNA cleavage activity of the mutated enzyme is less than about 25%, 10%, 5%, 1%, 0.1%, 0.01%, or lower with respect to its non-mutated form. Other mutations may be useful; where the Cas9 or other CRISPR enzyme is from a species other than *S. pyogenes*, mutations in corresponding amino acids may be made to achieve similar effects.

[0131] In some embodiments, an enzyme coding sequence encoding a CRISPR enzyme is codon optimized for expression in particular cells, such as eukaryotic cells. The eukaryotic cells may be those of or derived from a particular organism, such as a mammal, including but not limited to human, mouse, rat, rabbit, dog, or non-human primate. In general, codon optimization refers to a process of modifying a nucleic acid sequence for enhanced expression in the host cells of interest by replacing at least one codon (e.g. about or more than about 1, 2, 3, 4, 5, 10, 15, 20, 25, 50, or more codons) of the native sequence with codons that are more frequently or most frequently used in the genes of that host cell while maintaining the native amino acid sequence. Various species exhibit particular bias for certain codons of a particular amino acid. Codon bias (differences in codon usage between organisms) often correlates with the efficiency of translation of messenger RNA (mRNA), which is in turn believed to be dependent on, among other things, the properties of the codons being translated and the availability of particular transfer RNA (tRNA) molecules. The predominance of selected tRNAs in a cell is generally a reflection of the codons used most frequently in peptide synthesis. Accordingly, genes can be tailored for optimal gene expression in a given organism based on codon optimization. Codon usage tables are readily available, for example, at the “Codon Usage Database”, and these tables can be adapted in a number of ways. See Nakamura, Y., et al. “Codon usage tabulated from the international DNA sequence databases:

status for the year 2000” Nucl. Acids Res. 28:292 (2000). Computer algorithms for codon optimizing a particular sequence for expression in a particular host cell are also available, such as Gene Forge (Aptagen; Jacobus, Pa.), are also available. In some embodiments, one or more codons (e.g. 1, 2, 3, 4, 5, 10, 15, 20, 25, 50, or more, or all codons) in a sequence encoding a CRISPR enzyme correspond to the most frequently used codon for a particular amino acid.

[0132] In some embodiments, a vector encodes a CRISPR enzyme comprising one or more nuclear localization sequences (NLSs), such as about or more than about 1, 2, 3, 4, 5, 6, 7, 8, 9, 10, or more NLSs. In some embodiments, the CRISPR enzyme comprises about or more than about 1, 2, 3, 4, 5, 6, 7, 8, 9, 10, or more NLSs at or near the amino-terminus, about or more than about 1, 2, 3, 4, 5, 6, 7, 8, 9, 10, or more NLSs at or near the carboxy-terminus, or a combination of these (e.g. one or more NLS at the amino-terminus and one or more NLS at the carboxy terminus). When more than one NLS is present, each may be selected independently of the others, such that a single NLS may be present in more than one copy and/or in combination with one or more other NLSs present in one or more copies. In a preferred embodiment of the invention, the CRISPR enzyme comprises at most 6 NLSs. In some embodiments, an NLS is considered near the N- or C-terminus when the nearest amino acid of the NLS is within about 1, 2, 3, 4, 5, 10, 15, 20, 25, 30, 40, 50, or more amino acids along the polypeptide chain from the N- or C-terminus. Typically, an NLS consists of one or more short sequences of positively charged lysines or arginines exposed on the protein surface, but other types of NLS are known. Non-limiting examples of NLSs include an NLS sequence derived from: the NLS of the SV40 virus large T-antigen, having the amino acid sequence PKKKRKV (SEQ ID NO: 1); the NLS from nucleoplasmin (e.g. the nucleoplasmin bipartite NLS with the sequence KRPAATKKAGQAKKKK (SEQ ID NO: 2)); the c-myc NLS having the amino acid sequence PAAKRVKLD (SEQ ID NO: 3) or RQQRNELKRSP (SEQ ID NO: 4); the hRNPA1 M9 NLS having the sequence NQSSNFGPMKGGNFGGRSSGPYGGGGQYFAKPRN-QGGY (SEQ ID NO: 5); the sequence RMRIZFKNKGKD-TAELRRRRVEVSVELRKAKKDEQILKRRNV (SEQ ID NO: 6) of the IBB domain from importin-alpha; the sequences VSRKRPRP (SEQ ID NO: 7) and PPKKARED (SEQ ID NO: 8) of the myoma T protein; the sequence PPKKKKPL (SEQ ID NO: 9) of human p53; the sequence SALIKKKKKMAP (SEQ ID NO: 10) of mouse c-abl IV; the sequences DRLRR (SEQ ID NO: 11) and PKQKKRK (SEQ ID NO: 12) of the influenza virus NS1; the sequence RKLKKKIKKL (SEQ ID NO: 13) of the Hepatitis virus delta antigen; the sequence REKKKFLKRR (SEQ ID NO: 14) of the mouse Mx1 protein; the sequence KRK-GDEVGDVDEVAKKKSKK (SEQ ID NO: 15) of the human poly(ADP-ribose) polymerase; and the sequence RKCLQAGMNLARKTKK (SEQ ID NO: 16) of the steroid hormone receptors (human) glucocorticoid.

[0133] In general, the one or more NLSs are of sufficient strength to drive accumulation of the CRISPR enzyme in a detectable amount in the nucleus of a eukaryotic cell. In general, strength of nuclear localization activity may derive from the number of NLSs in the CRISPR enzyme, the particular NLS(s) used, or a combination of these factors. Detection of accumulation in the nucleus may be performed by any suitable technique. For example, a detectable marker

may be fused to the CRISPR enzyme, such that location within a cell may be visualized, such as in combination with a means for detecting the location of the nucleus (e.g. a stain specific for the nucleus such as DAPI). Examples of detectable markers include fluorescent proteins (such as Green fluorescent proteins, or GFP; RFP; CFP), and epitope tags (HA tag, flag tag, SNAP tag). Cell nuclei may also be isolated from cells, the contents of which may then be analyzed by any suitable process for detecting protein, such as immunohistochemistry, Western blot, or enzyme activity assay. Accumulation in the nucleus may also be determined indirectly, such as by an assay for the effect of CRISPR complex formation (e.g. assay for DNA cleavage or mutation at the target sequence, or assay for altered gene expression activity affected by CRISPR complex formation and/or CRISPR enzyme activity), as compared to a control not exposed to the CRISPR enzyme or complex, or exposed to a CRISPR enzyme lacking the one or more NLSs.

[0134] In general, a guide sequence is any polynucleotide sequence having sufficient complementarity with a target polynucleotide sequence to hybridize with the target sequence and direct sequence-specific binding of a CRISPR complex to the target sequence. In some embodiments, the degree of complementarity between a guide sequence and its corresponding target sequence, when optimally aligned using a suitable alignment algorithm, is about or more than about 50%, 60%, 75%, 80%, 85%, 90%, 95%, 97.5%, 99%, or more. Optimal alignment may be determined with the use of any suitable algorithm for aligning sequences, non-limiting example of which include the Smith-Waterman algorithm, the Needleman-Wunsch algorithm, algorithms based on the Burrows-Wheeler Transform (e.g. the Burrows Wheeler Aligner), ClustalW, Clustal X, BLAT, Novoalign (Novocraft Technologies, ELAND (Illumina, San Diego, Calif.), SOAP (available at soap.genomics.org.cn), and Maq (available at maq.sourceforge.net). In some embodiments, a guide sequence is about or more than about 5, 10, 11, 12, 13, 14, 15, 16, 17, 18, 19, 20, 21, 22, 23, 24, 25, 26, 27, 28, 29, 30, 35, 40, 45, 50, 75, or more nucleotides in length. In some embodiments, a guide sequence is less than about 75, 50, 45, 40, 35, 30, 25, 20, 15, 12, or fewer nucleotides in length. The ability of a guide sequence to direct sequence-specific binding of a CRISPR complex to a target sequence may be assessed by any suitable assay. For example, the components of a CRISPR system sufficient to form a CRISPR complex, including the guide sequence to be tested, may be provided to a host cell having the corresponding target sequence, such as by transfection with vectors encoding the components of the CRISPR sequence, followed by an assessment of preferential cleavage within the target sequence, such as by Surveyor assay as described herein. Similarly, cleavage of a target polynucleotide sequence may be evaluated in a test tube by providing the target sequence, components of a CRISPR complex, including the guide sequence to be tested and a control guide sequence different from the test guide sequence, and comparing binding or rate of cleavage at the target sequence between the test and control guide sequence reactions. Other assays are possible, and will occur to those skilled in the art.

[0135] A guide sequence may be selected to target any target sequence. In some embodiments, the target sequence is a sequence within a genome of a cell. Exemplary target sequences include those that are unique in the target genome. For example, for the *S. pyogenes* Cas9, a unique

target sequence in a genome may include a Cas9 target site of the form MMMMMMMMNNNNNNNNNNNNXGG (SEQ ID NO: 530) where NNNNNNNNNNNNXGG (SEQ ID NO: 531) (N is A, G, T, or C; and X can be anything) has a single occurrence in the genome. A unique target sequence in a genome may include an *S. pyogenes* Cas9 target site of the form MMMMMMMMNNNNNNNNNNNNXGG (SEQ ID NO: 532) where NNNNNNNNNNNNXGG (SEQ ID NO: 533) (N is A, G, T, or C; and X can be anything) has a single occurrence in the genome. For the *S. thermophilus* CRISPR1 Cas9, a unique target sequence in a genome may include a Cas9 target site of the form MMMMMM-MMNNNNNNNNNNNNXXAGAAW (SEQ ID NO: 17) where NNNNNNNNNNNXXAGAAW (SEQ ID NO: 18) (N is A, G, T, or C; X can be anything; and W is A or T) has a single occurrence in the genome. A unique target sequence in a genome may include an *S. thermophilus* CRISPR1 Cas9 target site of the form MMMMMMMM-MMNNNNNNNNNNNNXXAGAAW (SEQ ID NO: 19) where NNNNNNNNNNNXXAGAAW (SEQ ID NO: 20) (N is A, G, T, or C; X can be anything; and W is A or T) has a single occurrence in the genome. For the *S. pyogenes* Cas9, a unique target sequence in a genome may include a Cas9 target site of the form MMMMMM-MMNNNNNNNNNNNNXXGGXG (SEQ ID NO: 534) where NNNNNNNNNNNXXGGXG (SEQ ID NO: 535) (N is A, G, T, or C; and X can be anything) has a single occurrence in the genome. A unique target sequence in a genome may include an *S. pyogenes* Cas9 target site of the form MMMMMMMMNNNNNNNNNNNNXXGGXG (SEQ ID No.: 536) where NNNNNNNNNNNXXGGXG (SEQ ID NO: 537) (N is A, G, T, or C; and X can be anything) has a single occurrence in the genome. In each of these sequences "M" may be A, G, T, or C, and need not be considered in identifying a sequence as unique.

[0136] In some embodiments, a guide sequence is selected to reduce the degree of secondary structure within the guide sequence. Secondary structure may be determined by any suitable polynucleotide folding algorithm. Some programs are based on calculating the minimal Gibbs free energy. An example of one such algorithm is mFold, as described by Zuker and Stiegler (Nucleic Acids Res. 9 (1981), 133-148). Another example folding algorithm is the online webserver RNAfold, developed at Institute for Theoretical Chemistry at the University of Vienna, using the centroid structure prediction algorithm (see e.g. A. R. Gruber et al., 2008, *Cell* 106(1): 23-24; and PA Carr and GM Church, 2009, *Nature Biotechnology* 27(12): 1151-62). Further algorithms may be found in U.S. application Ser. No. TBA (attorney docket 44790.11.2022; Broad Reference BI-2013/004A); incorporated herein by reference.

[0137] In general, a tracr mate sequence includes any sequence that has sufficient complementarity with a tracr sequence to promote one or more of: (1) excision of a guide sequence flanked by tracr mate sequences in a cell containing the corresponding tracr sequence; and (2) formation of a CRISPR complex at a target sequence, wherein the CRISPR complex comprises the tracr mate sequence hybridized to the tracr sequence. In general, degree of complementarity is with reference to the optimal alignment of the tracr mate sequence and tracr sequence, along the length of the shorter of the two sequences. Optimal alignment may be determined by any suitable alignment algorithm, and may further account for secondary structures, such as self-

complementarity within either the tracr sequence or tracr mate sequence. In some embodiments, the degree of complementarity between the tracr sequence and tracr mate sequence along the length of the shorter of the two when optimally aligned is about or more than about 25%, 30%, 40%, 50%, 60%, 70%, 80%, 90%, 95%, 97.5%, 99%, or higher. Example illustrations of optimal alignment between a tracr sequence and a tracr mate sequence are provided in FIGS. 12B and 13B. In some embodiments, the tracr sequence is about or more than about 5, 6, 7, 8, 9, 10, 11, 12, 13, 14, 15, 16, 17, 18, 19, 20, 25, 30, 40, 50, or more nucleotides in length. In some embodiments, the tracr sequence and tracr mate sequence are contained within a single transcript, such that hybridization between the two produces a transcript having a secondary structure, such as a hairpin. Preferred loop forming sequences for use in hairpin structures are four nucleotides in length, and most preferably have the sequence GAAA. However, longer or shorter loop sequences may be used, as may alternative sequences. The sequences preferably include a nucleotide triplet (for example, AAA), and an additional nucleotide (for example C or G). Examples of loop forming sequences include CAAA and AAAG. In an embodiment of the invention, the transcript or transcribed polynucleotide sequence has at least two or more hairpins. In preferred embodiments, the transcript has two, three, four or five hairpins. In a further embodiment of the invention, the transcript has at most five hairpins. In some embodiments, the single transcript further includes a transcription termination sequence; preferably this is a polyT sequence, for example six T nucleotides. An example illustration of such a hairpin structure is provided in the lower portion of FIG. 13B, where the portion of the sequence 5' of the final "N" and upstream of the loop corresponds to the tracr mate sequence, and the portion of the sequence 3' of the loop corresponds to the tracr sequence. Further non-limiting examples of single polynucleotides comprising a guide sequence, a tracr mate sequence, and a tracr sequence are as follows (listed 5' to 3'), where "N" represents a base of a guide sequence, the first block of lower case letters represent the tracr mate sequence, and the second block of lower case letters represent the tracr sequence, and the final poly-T sequence represents the transcription terminator: (1) NNNNNNNNNNNNNNNNNgittttgtactctcaagattt-GAAAtaatcttgacagaagctacaagataaggctt catgccgaatacaacacctgtcattttatggcagggtgttttcgtatttaaTTTTTT (SEQ ID NO: 21); (2) NNNNNNNNNNNNNNNNNNNgittttgtactctca-GAAAtgcagaagctacaagataaggcttcatgccgaataca acacctgtcattttatggcagggtgttttcgtatttaaTTTTTT (SEQ ID NO: 22); (3) NNNNNNNNNNNNNNNNNNNgittttgtactctcaGAAAtgca-gaagctacaagataaggcttcatgccgaataca acacctgtcattttatggcagggtgtTTTTTT (SEQ ID NO: 23); (4) NNNNNNNNNNNNNNNNNNNNNgitttagagctaGAAAtag-caagtaaaataaggctagtcctgtatcaacttgaaaa agtggcaccgagtcgtgcTTTTTT (SEQ ID NO: 24); (5) NNNNNNNNNNNNNNNNNNNNNgitttagagcta-GAAATAGcaagtaaaataaggctagtcctgtatcaacttga aagtgTTTTTT (SEQ ID NO: 25); and (6) NNNNNNNNNNNNNNNNNNNNNgitttagagctagAAATAG-caagtaaaataaggctagtcctgtatcaTTTTTT TTT (SEQ ID NO: 26). In some embodiments, sequences (1) to (3) are used in combination with Cas9 from *S. thermophilus* CRISPR1. In some embodiments, sequences (4) to (6) are used in combination with Cas9 from *S. pyogenes*. In some embodiments,

the tracr sequence is a separate transcript from a transcript comprising the tracr mate sequence (such as illustrated in the top portion of FIG. 13B).

[0138] In some embodiments, a recombination template is also provided. A recombination template may be a component of another vector as described herein, contained in a separate vector, or provided as a separate polynucleotide. In some embodiments, a recombination template is designed to serve as a template in homologous recombination, such as within or near a target sequence nicked or cleaved by a CRISPR enzyme as a part of a CRISPR complex. A template polynucleotide may be of any suitable length, such as about or more than about 10, 15, 20, 25, 50, 75, 100, 150, 200, 500, 1000, or more nucleotides in length. In some embodiments, the template polynucleotide is complementary to a portion of a polynucleotide comprising the target sequence. When optimally aligned, a template polynucleotide might overlap with one or more nucleotides of a target sequences (e.g. about or more than about 1, 5, 10, 15, 20, 25, 30, 35, 40, 45, 50, 60, 70, 80, 90, 100 or more nucleotides). In some embodiments, when a template sequence and a polynucleotide comprising a target sequence are optimally aligned, the nearest nucleotide of the template polynucleotide is within about 1, 5, 10, 15, 20, 25, 50, 75, 100, 200, 300, 400, 500, 1000, 5000, 10000, or more nucleotides from the target sequence.

[0139] In some embodiments, the CRISPR enzyme is part of a fusion protein comprising one or more heterologous protein domains (e.g. about or more than about 1, 2, 3, 4, 5, 6, 7, 8, 9, 10, or more domains in addition to the CRISPR enzyme). A CRISPR enzyme fusion protein may comprise any additional protein sequence, and optionally a linker sequence between any two domains. Examples of protein domains that may be fused to a CRISPR enzyme include, without limitation, epitope tags, reporter gene sequences, and protein domains having one or more of the following activities: methylase activity, demethylase activity, transcription activation activity, transcription repression activity, transcription release factor activity, histone modification activity, RNA cleavage activity and nucleic acid binding activity. Non-limiting examples of epitope tags include histidine (His) tags, V5 tags, FLAG tags, influenza hemagglutinin (HA) tags, Myc tags, VSV-G tags, and thioredoxin (Trx) tags. Examples of reporter genes include, but are not limited to, glutathione-S-transferase (GST), horseradish peroxidase (HRP), chloramphenicol acetyltransferase (CAT) beta-galactosidase, beta-glucuronidase, luciferase, green fluorescent protein (GFP), HcRed, DsRed, cyan fluorescent protein (CFP), yellow fluorescent protein (YFP), and auto-fluorescent proteins including blue fluorescent protein (BFP). A CRISPR enzyme may be fused to a gene sequence encoding a protein or a fragment of a protein that bind DNA molecules or bind other cellular molecules, including but not limited to maltose binding protein (MBP), S-tag, Lex A DNA binding domain (DBD) fusions, GAL4 DNA binding domain fusions, and herpes simplex virus (HSV) BP16 protein fusions. Additional domains that may form part of a fusion protein comprising a CRISPR enzyme are described in US20110059502, incorporated herein by reference. In some embodiments, a tagged CRISPR enzyme is used to identify the location of a target sequence.

[0140] In some aspects, the invention provides methods comprising delivering one or more polynucleotides, such as or one or more vectors as described herein, one or more

transcripts thereof, and/or one or proteins transcribed therefrom, to a host cell. In some aspects, the invention further provides cells produced by such methods, and organisms (such as animals, plants, or fungi) comprising or produced from such cells. In some embodiments, a CRISPR enzyme in combination with (and optionally complexed with) a guide sequence is delivered to a cell. Conventional viral and non-viral based gene transfer methods can be used to introduce nucleic acids in mammalian cells or target tissues. Such methods can be used to administer nucleic acids encoding components of a CRISPR system to cells in culture, or in a host organism. Non-viral vector delivery systems include DNA plasmids, RNA (e.g. a transcript of a vector described herein), naked nucleic acid, and nucleic acid complexed with a delivery vehicle, such as a liposome. Viral vector delivery systems include DNA and RNA viruses, which have either episomal or integrated genomes after delivery to the cell. For a review of gene therapy procedures, see Anderson, *Science* 256:808-813 (1992); Nabel & Felgner, *TIBTECH* 11:211-217 (1993); Mitani & Caskey, *TIBTECH* 11:162-166 (1993); Dillon, *TIBTECH* 11:167-175 (1993); Miller, *Nature* 357:455-460 (1992); Van Brunt, *Biotechnology* 6(10):1149-1154 (1988); Vigne, *Restorative Neurology and Neuroscience* 8:35-36 (1995); Kremer & Perricaudet, *British Medical Bulletin* 51(1):31-44 (1995); Haddada et al., in *Current Topics in Microbiology and Immunology*, Doerfler and Böhm (eds) (1995); and Yu et al., *Gene Therapy* 1:13-26 (1994).

[0141] Methods of non-viral delivery of nucleic acids include lipofection, nucleofection, microinjection, biolistics, virosomes, liposomes, immunoliposomes, polycation or lipid:nucleic acid conjugates, naked DNA, artificial virions, and agent-enhanced uptake of DNA. Lipofection is described in e.g., U.S. Pat. Nos. 5,049,386, 4,946,787; and 4,897,355) and lipofection reagents are sold commercially (e.g., Transfectam™ and Lipofectin™). Cationic and neutral lipids that are suitable for efficient receptor-recognition lipofection of polynucleotides include those of Felgner, WO 91/17424; WO 91/16024. Delivery can be to cells (e.g. in vitro or ex vivo administration) or target tissues (e.g. in vivo administration).

[0142] The preparation of lipid:nucleic acid complexes, including targeted liposomes such as immunolipid complexes, is well known to one of skill in the art (see, e.g., *Crystal*, *Science* 270:404-410 (1995); Blaese et al., *Cancer Gene Ther.* 2:291-297 (1995); Behr et al., *Bioconjugate Chem.* 5:382-389 (1994); Remy et al., *Bioconjugate Chem.* 5:647-654 (1994); Gao et al., *Gene Therapy* 2:710-722 (1995); Ahmad et al., *Cancer Res.* 52:4817-4820 (1992); U.S. Pat. Nos. 4,186,183, 4,217,344, 4,235,871, 4,261,975, 4,485,054, 4,501,728, 4,774,085, 4,837,028, and 4,946,787).

[0143] The use of RNA or DNA viral based systems for the delivery of nucleic acids takes advantage of highly evolved processes for targeting a virus to specific cells in the body and trafficking the viral payload to the nucleus. Viral vectors can be administered directly to patients (in vivo) or they can be used to treat cells in vitro, and the modified cells may optionally be administered to patients (ex vivo). Conventional viral based systems could include retroviral, lentivirus, adenoviral, adeno-associated and herpes simplex virus vectors for gene transfer. Integration in the host genome is possible with the retrovirus, lentivirus, and adeno-associated virus gene transfer methods, often result-

ing in long term expression of the inserted transgene. Additionally, high transduction efficiencies have been observed in many different cell types and target tissues.

[0144] The tropism of a retrovirus can be altered by incorporating foreign envelope proteins, expanding the potential target population of target cells. Lentiviral vectors are retroviral vectors that are able to transduce or infect non-dividing cells and typically produce high viral titers. Selection of a retroviral gene transfer system would therefore depend on the target tissue. Retroviral vectors are comprised of cis-acting long terminal repeats with packaging capacity for up to 6-10 kb of foreign sequence. The minimum cis-acting LTRs are sufficient for replication and packaging of the vectors, which are then used to integrate the therapeutic gene into the target cell to provide permanent transgene expression. Widely used retroviral vectors include those based upon murine leukemia virus (MuLV), gibbon ape leukemia virus (GaLV), Simian Immuno deficiency virus (SIV), human immuno deficiency virus (HIV), and combinations thereof (see, e.g., Buchscher et al., *J. Virol.* 66:2731-2739 (1992); Johann et al., *J. Virol.* 66:1635-1640 (1992); Sommerfelt et al., *Virol.* 176:58-59 (1990); Wilson et al., *J. Virol.* 63:2374-2378 (1989); Miller et al., *J. Virol.* 65:2220-2224 (1991); PCT/US94/05700). In applications where transient expression is preferred, adenoviral based systems may be used. Adenoviral based vectors are capable of very high transduction efficiency in many cell types and do not require cell division. With such vectors, high titer and levels of expression have been obtained. This vector can be produced in large quantities in a relatively simple system. Adeno-associated virus ("AAV") vectors may also be used to transduce cells with target nucleic acids, e.g., in the *in vitro* production of nucleic acids and peptides, and for *in vivo* and *ex vivo* gene therapy procedures (see, e.g., West et al., *Virology* 160:38-47 (1987); U.S. Pat. No. 4,797,368; WO 93/24641; Kotin, *Human Gene Therapy* 5:793-801 (1994); Muzyczka, *J. Clin. Invest.* 94:1351 (1994). Construction of recombinant AAV vectors are described in a number of publications, including U.S. Pat. No. 5,173,414; Tratschin et al., *Mol. Cell. Biol.* 5:3251-3260 (1985); Tratschin, et al., *Mol. Cell. Biol.* 4:2072-2081 (1984); Hermonat & Muzyczka, *PNAS* 81:6466-6470 (1984); and Samulski et al., *J. Virol.* 63:03822-3828 (1989).

[0145] Packaging cells are typically used to form virus particles that are capable of infecting a host cell. Such cells include 293 cells, which package adenovirus, and ψ 2 cells or PA317 cells, which package retrovirus. Viral vectors used in gene therapy are usually generated by producing a cell line that packages a nucleic acid vector into a viral particle. The vectors typically contain the minimal viral sequences required for packaging and subsequent integration into a host, other viral sequences being replaced by an expression cassette for the polynucleotide(s) to be expressed. The missing viral functions are typically supplied in trans by the packaging cell line. For example, AAV vectors used in gene therapy typically only possess ITR sequences from the AAV genome which are required for packaging and integration into the host genome. Viral DNA is packaged in a cell line, which contains a helper plasmid encoding the other AAV genes, namely rep and cap, but lacking ITR sequences. The cell line may also be infected with adenovirus as a helper. The helper virus promotes replication of the AAV vector and expression of AAV genes from the helper plasmid. The helper plasmid is not packaged in significant amounts due to

a lack of ITR sequences. Contamination with adenovirus can be reduced by, e.g., heat treatment to which adenovirus is more sensitive than AAV. Additional methods for the delivery of nucleic acids to cells are known to those skilled in the art. See, for example, US20030087817, incorporated herein by reference.

[0146] In some embodiments, a host cell is transiently or non-transiently transfected with one or more vectors described herein. In some embodiments, a cell is transfected as it naturally occurs in a subject. In some embodiments, a cell that is transfected is taken from a subject. In some embodiments, the cell is derived from cells taken from a subject, such as a cell line. A wide variety of cell lines for tissue culture are known in the art. Examples of cell lines include, but are not limited to, C8161, CCRF-CEM, MOLT, mIMCD-3, NHDF, HeLa-S3, Huh1, Huh4, Huh7, HUVEC, HASMC, HEK293, HEK293T, MiaPaCell, Panc1, PC-3, TF1, CTLL-2, C1R, Rat6, CV1, RPTE, A10, T24, J82, A375, ARH-77, Calu, SW480, SW620, SKOV3, SK-UT, CaCo2, P388D1, SEM-K2, WEHI-231, HB56, TIB55, Jurkat, J45.01, LRMB, Bcl-1, BC-3, IC21, DLD2, Raw264.7, NRK, NRK-52E, MRC5, MEF, Hep G2, HeLa B, HeLa T4, COS, COS-1, COS-6, COS-M6A, BS-C-1 monkey kidney epithelial, BALB/3T3 mouse embryo fibroblast, 3T3 Swiss, 3T3-L1, 132-d5 human fetal fibroblasts; 10.1 mouse fibroblasts, 293-T, 3T3, 721, 9L, A2780, A2780ADR, A2780cis, A172, A20, A253, A431, A-549, ALC, B16, B35, BCP-1 cells, BEAS-2B, bEnd.3, BHK-21, BR 293, BxPC3, C3H-10T1/2, C6/36, Cal-27, CHO, CHO-7, CHO-IR, CHO-K1, CHO-K2, CHO-T, CHO Dhfr^{-/-}, COR-L23, COR-L23/CPR, COR-L23/5010, COR-L23/R23, COS-7, COV-434, CML T1, CMT, CT26, D17, DH82, DU145, DuCaP, EL4, EM2, EM3, EMT6/AR1, EMT6/AR10.0, FM3, H1299, H69, HB54, HB55, HCA2, HEK-293, HeLa, Hepalcc1c7, HL-60, HMEC, HT-29, Jurkat, JY cells, K562 cells, Ku812, KCL22, KG1, KYO1, LNCap, Ma-Mel 1-48, MC-38, MCF-7, MCF-10A, MDA-MB-231, MDA-MB-468, MDA-MB-435, MDCK II, MDCK II, MOR/0.2R, MONO-MAC 6, MTD-1A, MyEnd, NCI-H69/CPR, NCI-H69/LX10, NCI-H69/LX20, NCI-H69/LX4, NIH-3T3, NALM-1, NW-145, OPCN/OPCT cell lines, Peer, PNT-1A/PNT 2, RenCa, RIN-5F, RMA/RMAs, Saos-2 cells, Sf-9, SkBr3, T2, T-47D, T84, THP1 cell line, U373, U87, U937, VCaP, Vero cells, WM39, WT-49, X63, YAC-1, YAR, and transgenic varieties thereof. Cell lines are available from a variety of sources known to those with skill in the art (see, e.g., the American Type Culture Collection (ATCC) (Manassas, Va.)). In some embodiments, a cell transfected with one or more vectors described herein is used to establish a new cell line comprising one or more vector-derived sequences. In some embodiments, a cell transiently transfected with the components of a CRISPR system as described herein (such as by transient transfection of one or more vectors, or transfection with RNA), and modified through the activity of a CRISPR complex, is used to establish a new cell line comprising cells containing the modification but lacking any other exogenous sequence. In some embodiments, cells transiently or non-transiently transfected with one or more vectors described herein, or cell lines derived from such cells are used in assessing one or more test compounds.

[0147] In some embodiments, one or more vectors described herein are used to produce a non-human transgenic animal or transgenic plant. In some embodiments, the transgenic animal is a mammal, such as a mouse, rat, or

rabbit. In certain embodiments, the organism or subject is a plant. In certain embodiments, the organism or subject or plant is algae. Methods for producing transgenic plants and animals are known in the art, and generally begin with a method of cell transfection, such as described herein.

[0148] In one aspect, the invention provides for methods of modifying a target polynucleotide in a eukaryotic cell. In some embodiments, the method comprises allowing a CRISPR complex to bind to the target polynucleotide to effect cleavage of said target polynucleotide thereby modifying the target polynucleotide, wherein the CRISPR complex comprises a CRISPR enzyme complexed with a guide sequence hybridized to a target sequence within said target polynucleotide, wherein said guide sequence is linked to a tracr mate sequence which in turn hybridizes to a tracr sequence.

[0149] In one aspect, the invention provides a method of modifying expression of a polynucleotide in a eukaryotic cell. In some embodiments, the method comprises allowing a CRISPR complex to bind to the polynucleotide such that said binding results in increased or decreased expression of said polynucleotide; wherein the CRISPR complex comprises a CRISPR enzyme complexed with a guide sequence hybridized to a target sequence within said polynucleotide, wherein said guide sequence is linked to a tracr mate sequence which in turn hybridizes to a tracr sequence.

[0150] With recent advances in crop genomics, the ability to use CRISPR-Cas systems to perform efficient and cost effective gene editing and manipulation will allow the rapid selection and comparison of single and multiplexed genetic manipulations to transform such genomes for improved production and enhanced traits. In this regard reference is made to US patents and publications: U.S. Pat. No. 6,603,061—*Agrobacterium*-Mediated Plant Transformation Method; U.S. Pat. No. 7,868,149—Plant Genome Sequences and Uses Thereof and US 2009/0100536—Transgenic Plants with Enhanced Agronomic Traits, all the contents and disclosure of each of which are herein incorporated by reference in their entirety. In the practice of the invention, the contents and disclosure of Morrell et al “Crop genomics: advances and applications” *Nat Rev Genet.* 2011 December 29; 13(2):85-96 are also herein incorporated by reference in their entirety. In an advantageous embodiment of the invention, the CRISPR/Cas9 system is used to engineer microalgae (Example 15). Accordingly, reference herein to animal cells may also apply, mutatis mutandis, to plant cells unless otherwise apparent.

[0151] In one aspect, the invention provides for methods of modifying a target polynucleotide in a eukaryotic cell, which may be in vivo, ex vivo or in vitro. In some embodiments, the method comprises sampling a cell or population of cells from a human or non-human animal or plant (including micro-algae), and modifying the cell or cells. Culturing may occur at any stage ex vivo. The cell or cells may even be re-introduced into the non-human animal or plant (including micro-algae).

[0152] In plants, pathogens are often host-specific. For example, *Fusarium oxysporum* f sp. *lycopersici* causes tomato wilt but attacks only tomato, and *F. oxysporum* f *dianthii Puccinia graminis* f sp. *tritici* attacks only wheat. Plants have existing and induced defenses to resist most pathogens. Mutations and recombination events across plant generations lead to genetic variability that gives rise to susceptibility, especially as pathogens reproduce with more

frequency than plants. In plants there can be non-host resistance, e.g., the host and pathogen are incompatible. There can also be Horizontal Resistance, e.g., partial resistance against all races of a pathogen, typically controlled by many genes and Vertical Resistance, e.g., complete resistance to some races of a pathogen but not to other races, typically controlled by a few genes. In a Gene-for-Gene level, plants and pathogens evolve together, and the genetic changes in one balance changes in other. Accordingly, using Natural Variability, breeders combine most useful genes for Yield, Quality, Uniformity, Hardiness, Resistance. The sources of resistance genes include native or foreign Varieties, Heirloom Varieties, Wild Plant Relatives, and Induced Mutations, e.g., treating plant material with mutagenic agents. Using the present invention, plant breeders are provided with a new tool to induce mutations. Accordingly, one skilled in the art can analyze the genome of sources of resistance genes, and in Varieties having desired characteristics or traits employ the present invention to induce the rise of resistance genes, with more precision than previous mutagenic agents and hence accelerate and improve plant breeding programs.

[0153] In one aspect, the invention provides kits containing any one or more of the elements disclosed in the above methods and compositions. In some embodiments, the kit comprises a vector system and instructions for using the kit. In some embodiments, the vector system comprises (a) a first regulatory element operably linked to a tracr mate sequence and one or more insertion sites for inserting a guide sequence upstream of the tracr mate sequence, wherein when expressed, the guide sequence directs sequence-specific binding of a CRISPR complex to a target sequence in a eukaryotic cell, wherein the CRISPR complex comprises a CRISPR enzyme complexed with (1) the guide sequence that is hybridized to the target sequence, and (2) the tracr mate sequence that is hybridized to the tracr sequence; and/or (b) a second regulatory element operably linked to an enzyme-coding sequence encoding said CRISPR enzyme comprising a nuclear localization sequence. Elements may be provide individually or in combinations, and may be provided in any suitable container, such as a vial, a bottle, or a tube. In some embodiments, the kit includes instructions in one or more languages, for example in more than one language.

[0154] In some embodiments, a kit comprises one or more reagents for use in a process utilizing one or more of the elements described herein. Reagents may be provided in any suitable container. For example, a kit may provide one or more reaction or storage buffers. Reagents may be provided in a form that is usable in a particular assay, or in a form that requires addition of one or more other components before use (e.g. in concentrate or lyophilized form). A buffer can be any buffer, including but not limited to a sodium carbonate buffer, a sodium bicarbonate buffer, a borate buffer, a Tris buffer, a MOPS buffer, a HEPES buffer, and combinations thereof. In some embodiments, the buffer is alkaline. In some embodiments, the buffer has a pH from about 7 to about 10. In some embodiments, the kit comprises one or more oligonucleotides corresponding to a guide sequence for insertion into a vector so as to operably link the guide sequence and a regulatory element. In some embodiments, the kit comprises a homologous recombination template polynucleotide.

[0155] In one aspect, the invention provides methods for using one or more elements of a CRISPR system. The CRISPR complex of the invention provides an effective means for modifying a target polynucleotide. The CRISPR complex of the invention has a wide variety of utility including modifying (e.g., deleting, inserting, translocating, inactivating, activating) a target polynucleotide in a multiplicity of cell types. As such the CRISPR complex of the invention has a broad spectrum of applications in, e.g., gene therapy, drug screening, disease diagnosis, and prognosis. An exemplary CRISPR complex comprises a CRISPR enzyme complexed with a guide sequence hybridized to a target sequence within the target polynucleotide. The guide sequence is linked to a tracr mate sequence, which in turn hybridizes to a tracr sequence.

[0156] The target polynucleotide of a CRISPR complex can be any polynucleotide endogenous or exogenous to the eukaryotic cell. For example, the target polynucleotide can be a polynucleotide residing in the nucleus of the eukaryotic cell. The target polynucleotide can be a sequence coding a gene product (e.g., a protein) or a non-coding sequence (e.g., a regulatory polynucleotide or a junk DNA). Without wishing to be bound by theory, it is believed that the target sequence should be associated with a PAM (protospacer adjacent motif); that is, a short sequence recognized by the CRISPR complex. The precise sequence and length requirements for the PAM differ depending on the CRISPR enzyme used, but PAMs are typically 2-5 base pair sequences adjacent the protospacer (that is, the target sequence) Examples of PAM sequences are given in the examples section below, and the skilled person will be able to identify further PAM sequences for use with a given CRISPR enzyme.

[0157] The target polynucleotide of a CRISPR complex may include a number of disease-associated genes and polynucleotides as well as signaling biochemical pathway-associated genes and polynucleotides as listed in U.S. provisional patent applications 61/736,527 and 61/748,427, both entitled SYSTEMS METHODS AND COMPOSITIONS FOR SEQUENCE MANIPULATION filed on Dec. 12, 2012 and Jan. 2, 2013, respectively, the contents of all of which are herein incorporated by reference in their entirety.

[0158] Examples of target polynucleotides include a sequence associated with a signaling biochemical pathway, e.g., a signaling biochemical pathway-associated gene or polynucleotide. Examples of target polynucleotides include a disease associated gene or polynucleotide. A “disease-associated” gene or polynucleotide refers to any gene or polynucleotide which is yielding transcription or translation products at an abnormal level or in an abnormal form in cells derived from a disease-affected tissues compared with tissues or cells of a non disease control. It may be a gene that becomes expressed at an abnormally high level; it may be a gene that becomes expressed at an abnormally low level, where the altered expression correlates with the occurrence and/or progression of the disease. A disease-associated gene also refers to a gene possessing mutation(s) or genetic variation that is directly responsible or is in linkage disequilibrium with a gene(s) that is responsible for the etiology of a disease. The transcribed or translated products may be known or unknown, and may be at a normal or abnormal level.

[0159] Examples of disease-associated genes and polynucleotides are available from McKusick-Nathans Institute of Genetic Medicine, Johns Hopkins University (Baltimore, Md.) and National Center for Biotechnology Information, National Library of Medicine (Bethesda, Md.), available on the World Wide Web.

[0160] Examples of disease-associated genes and polynucleotides are listed in Tables A and B. Disease specific information is available from McKusick-Nathans Institute of Genetic Medicine, Johns Hopkins University (Baltimore, Md.) and National Center for Biotechnology Information, National Library of Medicine (Bethesda, Md.), available on the World Wide Web. Examples of signaling biochemical pathway-associated genes and polynucleotides are listed in Table C.

[0161] Mutations in these genes and pathways can result in production of improper proteins or proteins in improper amounts which affect function. Further examples of genes, diseases and proteins are hereby incorporated by reference from U.S. Provisional application 61/736,527 filed on Dec. 12, 2012 and 61/748,427 filed on Feb. 2, 2013. Such genes, proteins and pathways may be the target polynucleotide of a CRISPR complex.

TABLE A

DISEASE/DISORDERS	GENE(S)
Neoplasia	PTEN; ATM; ATR; EGFR; ERBB2; ERBB3; ERBB4; Notch1; Notch2; Notch3; Notch4; AKT; AKT2; AKT3; HIF; HIF1a; HIF3a; Met; HRG; Bel2; PPAR alpha; PPAR gamma; WT1 (Wilms Tumor); FGF Receptor Family members (5 members: 1, 2, 3, 4, 5); CDKN2a; APC; RB (retinoblastoma); MEN1; VHL; BRCA1; BRCA2; AR (Androgen Receptor); TSG101; IGF; IGF Receptor; Igfl (4 variants); Igf2 (3 variants); Igf 1 Receptor; Igf 2 Receptor; Bax; Bcl2; caspases family (9 members: 1, 2, 3, 4, 6, 7, 8, 9, 12); Kras; Apc
Age-related Macular Degeneration	Aber; Ccl2; Cc2; ep (ceruloplasmin); Timp3; cathepsinD; Vldlr; Ccr2
Schizophrenia	Neuregulin1 (Nrg1); Erb4 (receptor for Neuregulin); Complexin1 (Cplx1); Tph1 Tryptophan hydroxylase; Tph2 Tryptophan hydroxylase 2; Neurexin 1; GSK3; GSK3a; GSK3b
Disorders	5-HTT (Slc6a4); COMT; DRD (Drd1a); SLC6A3; DAOA; DTNBP1; Dao (Dao1)

TABLE A-continued

DISEASE/DISORDERS	GENE(S)
Trinucleotide Repeat Disorders	HTT (Huntington's Dx); SBMA/SMAX1/AR (Kennedy's Dx); FXN/X25 (Friedrich's Ataxia); ATX3 (Machado-Joseph's Dx); ATXN1 and ATXN2 (spinocerebellar ataxias); DMPK (myotonic dystrophy); Atrophin-1 and Atn1 (DRPLA Dx); CBP (Creb-BP - global instability); VLDLR (Alzheimer's); Atxn7; Atxn10
Fragile X Syndrome	FMR2; FXR1; FXR2; mGLUR5
Secretase Related Disorders	APH-1 (alpha and beta); Presenilin (Psen1); nicastrin (Ncstn); PEN-2
Others	Nos1; Parp1; Nat1; Nat2
Prion-related disorders	Prp
ALS	SOD1; ALS2; STEX; FUS; TARDBP; VEGF (VEGF-a; VEGF-b; VEGF-c)
Drug addiction	Prkce (alcohol); Drd2; Drd4; ABAT (alcohol); GRIA2; Grm5; Grin1; Htr1b; Grin2a; Drd3; Pdyn; Gria1 (alcohol)
Autism	Mecp2; BZRAP1; MDGA2; Sema5A; Neurexin 1; Fragile X (FMR2 (AFF2); FXR1; FXR2; Mglur5)
Alzheimer's Disease	E1; CHIP; UCH; UBB; Tau; LRP; PICALM; Clusterin; PS1; SORL1; CR1; Vldlr; Uba1; Uba3; CHIP28 (Aqp1, Aquaporin 1); Uchl1; Uchl3; APP
Inflammation	IL-10; IL-1 (IL-1a; IL-1b); IL-13; IL-17 (IL-17a (CTLA8); IL-17b; IL-17c; IL-17d; IL-17f); IL-23; Cx3cr1; ptpn22; TNFa; NOD2/CARD15 for IBD; IL-6; IL-12 (IL-12a; IL-12b); CTLA4; Cx3cl1
Parkinson's Disease	α-Synuclein; DJ-1; LRRK2; Parkin; PINK1

TABLE B

Blood and coagulation diseases and disorders	Anemia (CDAN1, CDA1, RPS19, DBA, PKLR, PK1, NT5C3, UMPH1, PSN1, RHAG, RH50A, NRAMP2, SPTB, ALAS2, ANH1, ASB, ABCB7, ABC7, ASAT); Bare lymphocyte syndrome (TAPBP, TPSN, TAP2, ABCB3, PSF2, RING11, MHC2TA, C2TA, RFX5, RFXAP, RFX5), Bleeding disorders (TBXA2R, P2RX1, P2X1); Factor H and factor H-like 1 (HF1, CFH, HUS); Factor V and factor VIII (MCFD2); Factor VII deficiency (F7); Factor X deficiency (F10); Factor XI deficiency (F11); Factor XII deficiency (F12, HAF); Factor XIIIa deficiency (F13A1, F13A); Factor XIIIb deficiency (F13B); Fanconi anemia (FANCA, FACA, FA1, FA, FAA, FAAP95, FAAP90, FLJ34064, FANCB, FANCC, FACC, BRCA2, FANCD1, FANCD2, FANCD, FADC, FAD, FANCE, FACE, FANCF, XRCC9, FANCG, BRIP1, BACH1, FANCI, PHF9, FANCL, FANCM, KIAA1596); Hemophagocytic lymphohistiocytosis disorders (PRF1, HPLH2, UNC13D, MUNC13-4, HPLH3, HLH3, FHL3); Hemophilia A (F8, F8C, HEMA); Hemophilia B (F9, HEMB); Hemorrhagic disorders (PI, ATT, F5); Leukocyte deficiencies and disorders (ITGB2, CD18, LCAMB, LAD, EIF2B1, EIF2BA, EIF2B2, EIF2B3, EIF2B5, LVWM, CACH, CLE, EIF2B4); Sickle cell anemia (HBB); Thalassemia (HBA2, HBB, HBD, LCRB, HBA1).
Cell dysregulation and oncology diseases and disorders	B-cell non-Hodgkin lymphoma (BCL7A, BCL7); Leukemia (TAL1, TCL5, SCL, TAL2, FLT3, NBS1, NBS, ZNFN1A1, IK1, LYF1, HOXD4, HOX4B, BCR, CML, PHL, ALL, ARNT, KRAS2, RASK2, GMPS, AF10, ARHGEF12, LARG, KIAA0382, CALM, CLTH, CEBPA, CEBP, CHIC2, BTL, FLT3, KIT, PBT, LPP, NPM1, NUP214, D9S46E, CAN, CAIN, RUNX1, CBFA2, AML1, WHSC1L1, NSD3, FLT3, AF1Q, NPM1, NUMA1, ZNF145, PLZF, PML, MYL, STAT5B, AF10, CALM, CLTH, ARL11, ARLTS1, P2RX7, P2X7, BCR, CML, PHL, ALL, GRAF, NF1, VRNF, WSS, NFNS, PTPN11, PTP2C, SHP2, NS1, BCL2, CCND1, PRAD1, BCL1, TCRA, GATA1, GF1, ERYF1, NFE1, ABL1, NQO1, DIA4, NMOR1, NUP214, D9S46E, CAN, CAIN). AIDS (KIR3DL1, NKAT3, NKB1, AMB11, KIR3DS1, IFNG, CXCL12, SDF1); Autoimmune lymphoproliferative syndrome (TNFRSF6, APT1, FAS, CD95, ALPS1A); Combined immunodeficiency. (IL2RG, SCIDX1, SCIDX, IMD4); HIV-1 (CCL5, SCYA5, D17S136E, TCP228), HIV susceptibility or infection (IL10, CSIF, CMKBR2, CCR2, CMKBR5, CCCR5 (CCR5)); Immunodeficiencies (CD3E, CD3G, AICDA, AID, HIGM2, TNFRSF5, CD40, UNG, DGU, HIGM4, TNFRSF5, CD40LG, HIGM1, IGM, FOXP3, IPEX, AIID, XPID, PIDX, TNFRSF14B, TAC1); Inflammation (IL-10, IL-1 (IL-1a, IL-1b), IL-13, IL-17 (IL-17a (CTLA8), IL-17b, IL-17c, IL-17d, IL-17f), IL-23, Cx3cr1,

TABLE B-continued

Metabolic, liver, kidney and protein diseases and disorders	<p>ptpn22, TNFa, NOD2/CARD15 for IBD, IL-6, IL-12 (IL-12a, IL-12b), CTLA4, Cx3c11); Severe combined immunodeficiencies (SCIDs)(JAK3, JAKL, DCLRE1C, ARTEMIS, SCIDA, RAG1, RAG2, ADA, PTPRC, CD45, LCA, IL7R, CD3D, T3D, IL2RG, SCIDX1, SCIDX, IMD4); Amyloid neuropathy (TTR, PALB); Amyloidosis (APOA1, APP, AAA, CVAP, AD1, GSN, FGA, LYZ, TTR, PALB); Cirrhosis (KRT18, KRT8, CIRH1A, NAIC, TEX292, KIAA1988); Cystic fibrosis (CFTR, ABCC7, CF, MRP7); Glycogen storage diseases (SLC2A2, GLUT2, G6PC, G6PT, G6PT1, GAA, LAMP2, LAMPB, AGL, GDE, GBE1, GYS2, PYGL, PFKM); Hepatic adenoma, 142330 (TCF1, HNF1A, MODY3), Hepatic failure, early onset, and neurologic disorder (SCOD1, SCO1), Hepatic lipase deficiency (LIPC), Hepatoblastoma, cancer and carcinomas (CTNNB1, PDGFRL, PDGRL, PRLTS, AXIN1, AXIN, CTNNB1, TP53, P53, LFS1, IGF2R, MPRI, MET, CASP8, MCH5; Medullary cystic kidney disease (UMOD, HNFJ, FJHN, MCKD2, ADMCKD2); Phenylketonuria (PAH, PKU1, QDPR, DHPR, PTS); Polycystic kidney and hepatic disease (FCYT, PKHD1, ARPKD, PKD1, PKD2, PKD4, PKDTS, PRKCSH, G19P1, PCLD, SEC63).</p>
Muscular/Skeletal diseases and disorders	<p>Becker muscular dystrophy (DMD, BMD, MYF6), Duchenne Muscular Dystrophy (DMD, BMD); Emery-Dreifuss muscular dystrophy (LMNA, LMN1, EMD2, FPLD, CMD1A, HGPS, LGMD1B, LMNA, LMN1, EMD2, FPLD, CMD1A); Facioscapulohumeral muscular dystrophy (FSHMD1A, FSHD1A); Muscular dystrophy (FKRP, MDC1C, LGMD2I, LAMA2, LAMM, LARGE, KIAA0609, MDC1D, FCMD, TTID, MYOT, CAPN3, CANP3, DYSF, LGMD2B, SGCG, LGMD2C, DMDA1, SCG3, SGCA, ADL, DAG2, LGMD2D, DMDA2, SGCB, LGMD2E, SGCD, SGD, LGMD2F, CMD1L, TCAP, LGMD2G, CMD1N, TRIM32, HT2A, LGMD2H, FKRP, MDC1C, LGMD2I, TTN, CMD1G, TMD, LGMD2J, POMT1, CAV3, LGMD1C, SEPN1, SELN, RSM1, PLEC1, PLTN, EBS1); Osteopetrosis (LRP5, BMND1, LRP7, LR3, OPPG, VBCH2, CLCN7, CLC7, OPTA2, OSTM1, GL, TCIRG1, TIRC7, OC116, OPTB1); Muscular atrophy (VAPB, VAPC, ALS8, SMN1, SMA1, SMA2, SMA3, SMA4, BSCL2, SPG17, GARS, SMAD1, CMT2D, HEXB, IGHMBP2, SMUBP2, CATF1, SMARD1).</p>
Neurological and neuronal diseases and disorders	<p>ALS (SOD1, ALS2, STEX, FUS, TARDBP, VEGF (VEGF-a, VEGF-b, VEGF-c); Alzheimer disease (APP, AAA, CVAP, AD1, APOE, AD2, PSEN2, AD4, STM2, APBB2, FE65L1, NOS3, PLAU, URK, ACE, DCP1, ACE1, MPO, PACIP1, PAXIP1L, PTP, A2M, BLMH, BMH, PSEN1, AD3); Autism (Mecp2, BZRAP1, MDGA2, Sema5A, Neurexin1, GLO1, MECP2, RTT, PPMX, MRX16, MRX79, NLGN3, NLGN4, KIAA1260, AUTSX2); Fragile X Syndrome (FMR2, FXR1, FXR2, mGLUR5); Huntington's disease and disease like disorders (HD, IT15, PRNP, PRIP, JPH3, JP3, HDL2, TBP, SCA17); Parkinson disease (NR4A2, NURR1, NOT, TINUR, SNCAIP, TBP, SCA17, SNCA, NACP, PARK1, PARK4, DJ1, PARK7, LRRK2, PARK8, PINK1, PARK6, UCHL1, PARK5, SNCA, NACP, PARK1, PARK4, PRKN, PARK2, PDJ, DBH, NDUFV2); Rett syndrome (MECP2, RTT, PPMX, MRX16, MRX79, CDKL5, STK9, MECP2, RTT, PPMX, MRX16, MRX79, x-Synuclein, DJ-1); Schizophrenia (Neuregulin1 (Nrg1), Erb4 (receptor for Neuregulin), Complexin1 (Cplx1), Tph1 Tryptophan hydroxylase, Tph2, Tryptophan hydroxylase 2, Neurexin 1, GSK3, GSK3a, GSK3b, 5-HTT (Slc6a4), COMT, DRD (Drd1a), SLC6A3, DAOA, DTNBP1, Dao (Dao1)); Secretase Related Disorders (APH-1 (alpha and beta), Presenilin (Psen1), nicastrin, (Ncstn), PEN-2, Nos1, Papp1, Nat1, Nat2); Trinucleotide Repeat Disorders (HTT (Huntington's Dx), SBMA/SMAX1/AR (Kennedy's Dx), FXN/X25 (Friedrich's Ataxia), ATX3 (Machado-Joseph's Dx), ATXN1 and ATXN2 (spinocerebellar ataxias), DMPK (myotonic dystrophy), Atrophin-1 and Atn1 (DRPLA Dx), CBP (Creb-BP-global instability), VLDLR (Alzheimer's), Atxn7, Atxn10).</p>
Ocular diseases and disorders	<p>Age-related macular degeneration (Aber, Ccl2, Cc2, cp (centioplasm), Timp3, cathepsinD, Vldlr, Ccr2); Cataract (CRYAA, CRYA1, CRYBB2, CRYB2, PITX3, BFSP2, CP49, CP47, CRYAA, CRYA1, PAX6, AN2, MGDA, CRYBA1, CRYB1, CRYGC, CRYG3, CCL, LIM2, MP19, CRYGD, CRYG4, BFSP2, CP49, CP47, HSF4, CTM, HSF4, CTM, MIP, AQP0, CRYAB, CRYA2, CTPP2, CRYBB1, CRYGD, CRYG4, CRYBB2, CRYB2, CRYGC, CRYG3, CCL, CRYAA, CRYA1, GJA8, CX50, CAE1, GJA3, CX46, CZP3, CAE3, CCM1, CAM, KRIT1); Corneal clouding and dystrophy (APOA1, TGFBI, CSD2, CDGG1, CSD, BIGH3, CDG2, TACSTD2, TROP2, M1S1, VSX1, RINX, PPCD, PPD, KTCN, COL8A2, FECD, PPCD2, PIP5K3, CFD); Cornea plana congenital (KERA, CNA2); Glaucoma (MYOC, TIGR, GLC1A, JOAG, GPOA, OPTN, GLC1E, FIP2, HYPL, NRP, CYP1B1, GLC3A, OPA1,</p>

TABLE B-continued

NTG, NPG, CYP1B1, GLC3A); Leber congenital amaurosis (CRB1, RP12, CRX, CORD2, CRD, RPGRIP1, LCA6, CORD9, RPE65, RP20, AIPL1, LCA4, GUCY2D, GUC2D, LCA1, CORD6, RDH12, LCA3); Macular dystrophy (ELOVL4, ADMD, STGD2, STGD3, RDS, RP7, PRPH2, PRPH, AVMD, AOFMD, VMD2).

TABLE C

CELLULAR FUNCTION	GENES
PI3K/AKT Signaling	PRKCE; ITGAM; ITGA5; IRAK1; PRKAA2; EIF2AK2; PTEN; EIF4E; PRKCZ; GRK6; MAPK1; TSC1; PLK1; AKT2; IKKBK; PIK3CA; CDK8; CDKN1B; NFKB2; BCL2; PIK3CB; PPP2R1A; MAPK8; BCL2L1; MAPK3; TSC2; ITGA1; KRAS; EIF4EBP1; RELA; PRKCD; NOS3; PRKAA1; MAPK9; CDK2; PPP2CA; PIM1; ITGB7; YWHAZ; ILK; TP53; RAF1; IKKBK; RELB; DYRK1A; CDKN1A; ITGB1; MAP2K2; JAK1; AKT1; JAK2; PIK3R1; CHUK; PDPK1; PPP2R5C; CTNNB1; MAP2K1; NFKB1; PAK3; ITGB3; CCND1; GSK3A; FRAP1; SFN; ITGA2; TTK; CSNK1A1; BRAF; GSK3B; AKT3; FOXO1; SGK; HSP90AA1; RPS6KB1
ERK/MAPK Signaling	PRKCE; ITGAM; ITGA5; HSPB1; IRAK1; PRKAA2; EIF2AK2; RAC1; RAP1A; TLN1; EIF4E; ELK1; GRK6; MAPK1; RAC2; PLK1; AKT2; PIK3CA; CDK8; CREB1; PRKCI; PTK2; FOS; RPS6KA4; PIK3CB; PPP2R1A; PIK3C3; MAPK8; MAPK3; ITGA1; ETS1; KRAS; MYCN; EIF4EBP1; PPARG; PRKCD; PRKAA1; MAPK9; SRC; CDK2; PPP2CA; PIM1; PIK3C2A; ITGB7; YWHAZ; PPP1CC; KSR1; PXN; RAF1; FYN; DYRK1A; ITGB1; MAP2K2; PAK4; PIK3R1; STAT3; PPP2R5C; MAP2K1; PAK3; ITGB3; ESR1; ITGA2; MYC; TTK; CSNK1A1; CRKL; BRAF; ATF4; PRKCA; SRF; STAT1; SGK
Glucocorticoid Receptor Signaling	RAC1; TAF4B; EP300; SMAD2; TRAF6; PCAF; ELK1; MAPK1; SMAD3; AKT2; IKKBK; NCOR2; UBE2I; PIK3CA; CREB1; FOS; HSPA5; NFKB2; BCL2; MAP3K14; STAT5B; PIK3CB; PIK3C3; MAPK8; BCL2L1; MAPK3; TSC2D3; MAPK10; NRIP1; KRAS; MAPK13; RELA; STAT5A; MAPK9; NOS2A; PBX1; NR3C1; PIK3C2A; CDKN1C; TRAF2; SERPINE1; NCOA3; MAPK14; TNF; RAF1; IKKBK; MAP3K7; CREBBP; CDKN1A; MAP2K2; JAK1; IL8; NCOA2; AKT1; JAK2; PIK3R1; CHUK; STAT3; MAP2K1; NFKB1; TGFBR1; ESR1; SMAD4; CEBPB; JUN; AR; AKT3; CCL2; MMP1; STAT1; IL6; HSP90AA1
Axonal Guidance Signaling	PRKCE; ITGAM; ROCK1; ITGA5; CXCR4; ADAM12; IGF1; RAC1; RAP1A; EIF4E; PRKCZ; NRP1; NTRK2; ARHGEF7; SMO; ROCK2; MAPK1; PGF; RAC2; PTPN11; GNAS; AKT2; PIK3CA; ERBB2; PRKCI; PTK2; CFL1; GNAQ; PIK3CB; CXCL12; PIK3C3; WNT11; PRKD1; GNB2L1; ABL1; MAPK3; ITGA1; KRAS; RHOA; PRKCD; PIK3C2A; ITGB7; GLI2; PXN; VASP; RAF1; FYN; ITGB1; MAP2K2; PAK4; ADAM17; AKT1; PIK3R1; GLI1; WNT5A; ADAM10; MAP2K1; PAK3; ITGB3; CDC42; VEGFA; ITGA2; EPHA8; CRKL; RND1; GSK3B; AKT3; PRKCA
Ephrin Receptor Signaling	PRKCE; ITGAM; ROCK1; ITGA5; CXCR4; IRAK1; PRKAA2; EIF2AK2; RAC1; RAP1A; GRK6; ROCK2; MAPK1; PGF; RAC2; PTPN11; GNAS; PLK1; AKT2; DOK1; CDK8; CREB1; PTK2; CFL1; GNAQ; MAP3K14; CXCL12; MAPK8; GNB2L1; ABL1; MAPK3; ITGA1; KRAS; RHOA; PRKCD; PRKAA1; MAPK9; SRC; CDK2; PIM1; ITGB7; PXN; RAF1; FYN; DYRK1A; ITGB1; MAP2K2; PAK4; AKT1; JAK2; STAT3; ADAM10; MAP2K1; PAK3; ITGB3; CDC42; VEGFA; ITGA2; EPHA8; TTK; CSNK1A1; CRKL; BRAF; PTPN13; ATF4; AKT3; SGK
Actin Cytoskeleton Signaling	ACTN4; PRKCE; ITGAM; ROCK1; ITGA5; IRAK1; PRKAA2; EIF2AK2; RAC1; INS; ARHGEF7; GRK6; ROCK2; MAPK1; RAC2; PLK1; AKT2; PIK3CA; CDK8; PTK2; CFL1; PIK3CB; MYH9; DIAPH1; PIK3C3; MAPK8;

TABLE C-continued

CELLULAR FUNCTION	GENES
	F2R; MAPK3; SLC9A1; ITGA1; KRAS; RHOA; PRKCD; PRKAA1; MAPK9; CDK2; PIM1; PIK3C2A; ITGB7; PPP1CC; PXN; VIL2; RAF1; GSN; DYRK1A; ITGB1; MAP2K2; PAK4; PIP5K1A; PIK3R1; MAP2K1; PAK3; ITGB3; CDC42; APC; ITGA2; TTK; CSNK1A1; CRKL; BRAF; VAV3; SGK
Huntington's Disease Signaling	PRKCE; IGF1; EP300; RCOR1; PRKCZ; HDAC4; TGM2; MAPK1; CAPNS1; AKT2; EGFR; NCOR2; SP1; CAPN2; PIK3CA; HDAC5; CREB1; PRKCI; HSPA5; REST; GNAQ; PIK3CB; PIK3C3; MAPK8; IGF1R; PRKD1; GNB2L1; BCL2L1; CAPN1; MAPK3; CASP8; HDAC2; HDAC7A; PRKCD; HDAC11; MAPK9; HDAC9; PIK3C2A; HDAC3; TP53; CASP9; CREBBP; AKT1; PIK3R1; PDPK1; CASP1; APAF1; FRAP1; CASP2; JUN; BAX; ATF4; AKT3; PRKCA; CLTC; SGK; HDAC6; CASP3
Apoptosis Signaling	PRKCE; ROCK1; BID; IRAK1; PRKAA2; EIF2AK2; BAK1; BIRC4; GRK6; MAPK1; CAPNS1; PLK1; AKT2; IKBKB; CAPN2; CDK8; FAS; NFKB2; BCL2; MAP3K14; MAPK8; BCL2L1; CAPN1; MAPK3; CASP8; KRAS; RELA; PRKCD; PRKAA1; MAPK9; CDK2; PIM1; TP53; TNF; RAF1; IKBKG; RELB; CASP9; DYRK1A; MAP2K2; CHUK; APAF1; MAP2K1; NFKB1; PAK3; LMNA; CASP2; BIRC2; TTK; CSNK1A1; BRAF; BAX; PRKCA; SGK; CASP3; BIRC3; PARP1
B Cell Receptor Signaling	RAC1; PTEN; LYN; ELK1; MAPK1; RAC2; PTPN11;
	AKT2; IKBKB; PIK3CA; CREB1; SYK; NFKB2; CAMK2A; MAP3K14; PIK3CB; PIK3C3; MAPK8; BCL2L1; ABL1; MAPK3; ETS1; KRAS; MAPK13; RELA; PTPN6; MAPK9; EGR1; PIK3C2A; BTK; MAPK14; RAF1; IKBKG; RELB; MAP3K7; MAP2K2; AKT1; PIK3R1; CHUK; MAP2K1; NFKB1; CDC42; GSK3A; FRAP1; BCL6; BCL10; JUN; GSK3B; ATF4; AKT3; VAV3; RPS6KB1
Leukocyte Extravasation Signaling	ACTN4; CD44; PRKCE; ITGAM; ROCK1; CXCR4; CYBA; RAC1; RAP1A; PRKCZ; ROCK2; RAC2; PTPN11; MMP14; PIK3CA; PRKCI; PTK2; PIK3CB; CXCL12; PIK3C3; MAPK8; PRKD1; ABL1; MAPK10; CYBB; MAPK13; RHOA; PRKCD; MAPK9; SRC; PIK3C2A; BTK; MAPK14; NOX1; PXN; VIL2; VASP; ITGB1; MAP2K2; CTNND1; PIK3R1; CTNNB1; CLDN1; CDC42; F11R; ITK; CRKL; VAV3; CTTN; PRKCA; MMP1; MMP9
Integrin Signaling	ACTN4; ITGAM; ROCK1; ITGA5; RAC1; PTEN; RAP1A; TLN1; ARHGEF7; MAPK1; RAC2; CAPNS1; AKT2; CAPN2; PIK3CA; PTK2; PIK3CB; PIK3C3; MAPK8; CAV1; CAPN1; ABL1; MAPK3; ITGA1; KRAS; RHOA; SRC; PIK3C2A; ITGB7; PPP1CC; ILK; PXN; VASP; RAF1; FYN; ITGB1; MAP2K2; PAK4; AKT1; PIK3R1; TNK2; MAP2K1; PAK3; ITGB3; CDC42; RND3; ITGA2; CRKL; BRAF; GSK3B; AKT3
Acute Phase Response Signaling	IRAK1; SOD2; MYD88; TRAF6; ELK1; MAPK1; PTPN11; AKT2; IKBKB; PIK3CA; FOS; NFKB2; MAP3K14; PIK3CB; MAPK8; RIPK1; MAPK3; IL6ST; KRAS; MAPK13; IL6R; RELA; SOCS1; MAPK9; FTL; NR3C1; TRAF2; SERPINE1; MAPK14; TNF; RAF1; PDK1; IKBKG; RELB; MAP3K7; MAP2K2; AKT1; JAK2; PIK3R1; CHUK; STAT3; MAP2K1; NFKB1; FRAP1; CEBPB; JUN; AKT3; IL1R1; IL6
PTEN Signaling	ITGAM; ITGA5; RAC1; PTEN; PRKCZ; BCL2L11; MAPK1; RAC2; AKT2; EGFR; IKBKB; CBL; PIK3CA; CDKN1B; PTK2; NFKB2; BCL2; PIK3CB; BCL2L1; MAPK3; ITGA1; KRAS; ITGB7; ILK; PDGFRB; INSR; RAF1; IKBKG; CASP9; CDKN1A; ITGB1; MAP2K2; AKT1; PIK3R1; CHUK; PDGFRA; PDPK1; MAP2K1; NFKB1; ITGB3; CDC42; CCND1; GSK3A; ITGA2; GSK3B; AKT3; FOXO1; CASP3; RPS6KB1
p53 Signaling	PTEN; EP300; BBC3; PCAF; FASN; BRCA1; GADD45A; BIRC5; AKT2; PIK3CA; CHEK1; TP53INP1; BCL2; PIK3CB; PIK3C3; MAPK8; THBS1; ATR; BCL2L1; E2F1; PMAIP1; CHEK2; TNFRSF10B; TP73; RB1; HDAC9; CDK2; PIK3C2A; MAPK14; TP53; LRDD; CDKN1A; HIPK2; AKT1; PIK3R1; RRM2B; APAF1; CTNNB1; SIRT1; CCND1; PRKDC; ATM; SFN; CDKN2A; JUN; SNAI2; GSK3B; BAX; AKT3

TABLE C-continued

CELLULAR FUNCTION	GENES
Aryl Hydrocarbon Receptor Signaling	HSPB1; EP300; FASN; TGM2; RXRA; MAPK1; NQO1; NCOR2; SP1; ARNT; CDKN1B; FOS; CHEK1; SMARCA4; NFKB2; MAPK8; ALDH1A1; ATR; E2F1; MAPK3; NRIP1; CHEK2; RELA; TP73; GSTP1; RB1; SRC; CDK2; AHR; NFE2L2; NCOA3; TP53; TNF; CDKN1A; NCOA2; APAF1; NFKB1; CCND1; ATM; ESR1; CDKN2A; MYC; JUN; ESR2; BAX; IL6; CYP1B1; HSP90AA1
Xenobiotic Metabolism Signaling	PRKCE; EP300; PRK CZ; RXRA; MAPK1; NQO1; NCOR2; PIK3CA; ARNT; PRKCI; NFKB2; CAMK2A; PIK3CB; PPP2R1A; PIK3C3; MAPK8; PRKD1; ALDH1A1; MAPK3; NRIP1; KRAS; MAPK13; PRKCD; GSTP1; MAPK9; NOS2A; ABCB1; AHR; PPP2CA; FTL; NFE2L2; PIK3C2A; PPARGC1A; MAPK14; TNF; RAF1; CREBBP; MAP2K2; PIK3R1; PPP2R5C; MAP2K1; NFKB1; KEAP1; PRKCA; EIF2AK3; IL6; CYP1B1; HSP90AA1
SAPK/JNK Signaling	PRKCE; IRAK1; PRKAA2; EIF2AK2; RAC1; ELK1; GRK6; MAPK1; GADD45A; RAC2; PLK1; AKT2; PIK3CA; FADD; CDK8; PIK3CB; PIK3C3; MAPK8; RIPK1; GNB2L1; IRS1; MAPK3; MAPK10; DAXX; KRAS; PRKCD; PRKAA1; MAPK9; CDK2; PIM1; PIK3C2A; TRAF2; TP53; LCK; MAP3K7; DYRK1A; MAP2K2; PIK3R1; MAP2K1; PAK3; CDC42; JUN; TTK; CSNK1A1; CRKL; BRAF; SGK
PPAr/RXR Signaling	PRKAA2; EP300; INS; SMAD2; TRAF6; PPARA; FASN; RXRA; MAPK1; SMAD3; GNAS; IKKBK; NCOR2; ABCA1; GNAQ; NFKB2; MAP3K14; STAT5B; MAPK8; IRS1; MAPK3; KRAS; RELA; PRKAA1; PPARGC1A; NCOA3; MAPK14; INSR; RAF1; IKKBK; RELB; MAP3K7; CREBBP; MAP2K2; JAK2; CHUK; MAP2K1; NFKB1; TGFBF1; SMAD4; JUN; IL1R1; PRKCA; IL6; HSP90AA1; ADIPOQ
NF-KB Signaling	IRAK1; EIF2AK2; EP300; INS; MYD88; PRK CZ; TRAF6; TBK1; AKT2; EGFR; IKKBK; PIK3CA; BTRC; NFKB2; MAP3K14; PIK3CB; PIK3C3; MAPK8; RIPK1; HDAC2; KRAS; RELA; PIK3C2A; TRAF2; TLR4; PDGFRB; TNF; INSR; LCK; IKKBK; RELB; MAP3K7; CREBBP; AKT1; PIK3R1; CHUK; PDGFRA; NFKB1; TLR2; BCL10; GSK3B; AKT3; TNFAIP3; IL1R1
Neuregulin Signaling	ERBB4; PRKCE; ITGAM; ITGA5; PTEN; PRK CZ; ELK1; MAPK1; PTPN11; AKT2; EGFR; ERBB2; PRKCI; CDKN1B; STAT5B; PRKD1; MAPK3; ITGA1; KRAS; PRKCD; STAT5A; SRC; ITGB7; RAF1; ITGB1; MAP2K2; ADAM17; AKT1; PIK3R1; PDPK1; MAP2K1; ITGB3; EREG; FRAP1; PSEN1; ITGA2; MYC; NRG1; CRKL; AKT3; PRKCA; HSP90AA1; RPS6KB1
Wnt & Beta catenin Signaling	CD44; EP300; LRP6; DVL3; CSNK1E; GJA1; SMO; AKT2; PIN1; CDH1; BTRC; GNAQ; MARK2; PPP2R1A; WNT11; SRC; DKK1; PPP2CA; SOX6; SFRP2; ILK; LEF1; SOX9; TP53; MAP3K7; CREBBP; TCF7L2; AKT1; PPP2R5C; WNT5A; LRP5; CTNBN1; TGFBF1; CCND1; GSK3A; DVL1; APC; CDKN2A; MYC; CSNK1A1; GSK3B; AKT3; SOX2
Insulin Receptor Signaling	PTEN; INS; EIF4E; PTPN1; PRK CZ; MAPK1; TSC1; PTPN11; AKT2; CBL; PIK3CA; PRKCI; PIK3CB; PIK3C3; MAPK8; IRS1; MAPK3; TSC2; KRAS; EIF4EBP1; SLC2A4; PIK3C2A; PPP1CC; INSR; RAF1; FYN; MAP2K2; JAK1; AKT1; JAK2; PIK3R1; PDPK1; MAP2K1; GSK3A; FRAP1; CRKL; GSK3B; AKT3; FOXO1; SGK; RPS6KB1
IL-6 Signaling	HSPB1; TRAF6; MAPKAPK2; ELK1; MAPK1; PTPN11; IKKBK; FOS; NFKB2; MAP3K14; MAPK8; MAPK3; MAPK10; IL6ST; KRAS; MAPK13; IL6R; RELA; SOCS1; MAPK9; ABCB1; TRAF2; MAPK14; TNF; RAF1; IKKBK; RELB; MAP3K7; MAP2K2; IL8; JAK2; CHUK; STAT3; MAP2K1; NFKB1; CEBPB; JUN; IL1R1; SRF; IL6

TABLE C-continued

CELLULAR FUNCTION	GENES
Hepatic Cholestasis	PRKCE; IRAK1; INS; MYD88; PRKCZ; TRAF6; PPARA; RXRA; IKKBK; PRKCI; NFKB2; MAP3K14; MAPK8; PRKD1; MAPK10; RELA; PRKCD; MAPK9; ABCB1; TRAF2; TLR4; TNF; INSR; IKBKG; RELB; MAP3K7; IL8; CHUK; NR1H2; TJP2; NFKB1; ESR1; SREBF1; FGFR4; JUN; IL1R1; PRKCA; IL6
IGF-1 Signaling	IGF1; PRKCZ; ELK1; MAPK1; PTPN11; NEDD4; AKT2; PIK3CA; PRKCI; PTK2; FOS; PIK3CB; PIK3C3; MAPK8; IGF1R; IRS1; MAPK3; IGFBP7; KRAS; PIK3C2A; YWHAZ; PXN; RAF1; CASP9; MAP2K2; AKT1; PIK3R1; PDPK1; MAP2K1; IGFBP2; SFN; JUN; CYR61; AKT3; FOXO1; SRF; CTGF; RPS6KB1
NRF2-mediated Oxidative Stress Response	PRKCE; EP300; SOD2; PRKCZ; MAPK1; SQSTM1; NQO1; PIK3CA; PRKCI; FOS; PIK3CB; PIK3C3; MAPK8; PRKD1; MAPK3; KRAS; PRKCD; GSTP1; MAPK9; FTL; NFE2L2; PIK3C2A; MAPK14; RAF1; MAP3K7; CREBBP; MAP2K2; AKT1; PIK3R1; MAP2K1; PPIB; JUN; KEAP1; GSK3B; ATF4; PRKCA; EIF2AK3; HSP90AA1
Hepatic Fibrosis/Hepatic Stellate Cell Activation	EDN1; IGF1; KDR; FLT1; SMAD2; FGFR1; MET; PGF; SMAD3; EGFR; FAS; CSF1; NFKB2; BCL2; MYH9; IGF1R; IL6R; RELA; TLR4; PDGFRB; TNF; RELB; IL8; PDGFRA; NFKB1; TGFB1; SMAD4; VEGFA; BAX; IL1R1; CCL2; HGF; MMP1; STAT1; IL6; CTGF; MMP9
PPAR Signaling	EP300; INS; TRAF6; PPARA; RXRA; MAPK1; IKKBK; NCOR2; FOS; NFKB2; MAP3K14; STAT5B; MAPK3; NRIP1; KRAS; PPARG; RELA; STAT5A; TRAF2; PPARGC1A; PDGFRB; TNF; INSR; RAF1; IKBKG; RELB; MAP3K7; CREBBP; MAP2K2; CHUK; PDGFRA; MAP2K1; NFKB1; JUN; IL1R1; HSP90AA1
Fc Epsilon RI Signaling	PRKCE; RAC1; PRKCZ; LYN; MAPK1; RAC2; PTPN11; AKT2; PIK3CA; SYK; PRKCI; PIK3CB; PIK3C3; MAPK8; PRKD1; MAPK3; MAPK10; KRAS; MAPK13; PRKCD; MAPK9; PIK3C2A; BTK; MAPK14; TNF; RAF1; FYN; MAP2K2; AKT1; PIK3R1; PDPK1; MAP2K1; AKT3; VAV3; PRKCA
G-Protein Coupled Receptor Signaling	PRKCE; RAP1A; RGS16; MAPK1; GNAS; AKT2; IKKBK; PIK3CA; CREB1; GNAQ; NFKB2; CAMK2A; PIK3CB; PIK3C3; MAPK3; KRAS; RELA; SRC; PIK3C2A; RAF1; IKBKG; RELB; FYN; MAP2K2; AKT1; PIK3R1; CHUK; PDPK1; STAT3; MAP2K1; NFKB1; BRAF; ATF4; AKT3; PRKCA
Inositol Phosphate Metabolism	PRKCE; IRAK1; PRKAA2; EIF2AK2; PTEN; GRK6; MAPK1; PLK1; AKT2; PIK3CA; CDK8; PIK3CB; PIK3C3; MAPK8; MAPK3; PRKCD; PRKAA1; MAPK9; CDK2; PIM1; PIK3C2A; DYRK1A; MAP2K2; PIP5K1A; PIK3R1; MAP2K1; PAK3; ATM; TTK; CSNK1A1; BRAF; SGK
PDGF Signaling	EIF2AK2; ELK1; ABL2; MAPK1; PIK3CA; FOS; PIK3CB; PIK3C3; MAPK8; CAV1; ABL1; MAPK3; KRAS; SRC; PIK3C2A; PDGFRB; RAF1; MAP2K2; JAK1; JAK2; PIK3R1; PDGFRA; STAT3; SPHK1; MAP2K1; MYC; JUN; CRKL; PRKCA; SRF; STAT1; SPHK2
VEGF Signaling	ACTN4; ROCK1; KDR; FLT1; ROCK2; MAPK1; PGF; AKT2; PIK3CA; ARNT; PTK2; BCL2; PIK3CB; PIK3C3; BCL2L1; MAPK3; KRAS; HIF1A; NOS3; PIK3C2A; PXN; RAF1; MAP2K2; ELAVL1; AKT1; PIK3R1; MAP2K1; SFN; VEGFA; AKT3; FOXO1; PRKCA
Natural Killer Cell Signaling	PRKCE; RAC1; PRKCZ; MAPK1; RAC2; PTPN11; KIR2DL3; AKT2; PIK3CA; SYK; PRKCI; PIK3CB; PIK3C3; PRKD1; MAPK3; KRAS; PRKCD; PTPN6; PIK3C2A; LCK; RAF1; FYN; MAP2K2; PAK4; AKT1; PIK3R1; MAP2K1; PAK3; AKT3; VAV3; PRKCA
Cell Cycle: G1/S Checkpoint Regulation	HDAC4; SMAD3; SUV39H1; HDAC5; CDKN1B; BTRC; ATR; ABL1; E2F1; HDAC2; HDAC7A; RB1; HDAC11; HDAC9; CDK2; E2F2; HDAC3; TP53; CDKN1A; CCND1; E2F4; ATM; RBL2; SMAD4; CDKN2A; MYC; NRG1; GSK3B; RBL1; HDAC6
T Cell Receptor Signaling	RAC1; ELK1; MAPK1; IKKBK; CBL; PIK3CA; FOS; NFKB2; PIK3CB; PIK3C3; MAPK8; MAPK3; KRAS; RELA; PIK3C2A; BTK; LCK; RAF1; IKBKG; RELB; FYN; MAP2K2; PIK3R1; CHUK; MAP2K1; NFKB1; ITK; BCL10; JUN; VAV3

TABLE C-continued

CELLULAR FUNCTION	GENES
Death Receptor Signaling	CRADD; HSPB1; BID; BIRC4; TBK1; IKKBK; FADD; FAS; NFKB2; BCL2; MAP3K14; MAPK8; RIPK1; CASP8; DAXX; TNFRSF10B; RELA; TRAF2; TNF; IKBK; RELB; CASP9; CHUK; APAF1; NFKB1; CASP2; BIRC2; CASP3; BIRC3
FGF Signaling	RAC1; FGFR1; MET; MAPKAPK2; MAPK1; PTPN11; AKT2; PIK3CA; CREB1; PIK3CB; PIK3C3; MAPK8; MAPK3; MAPK13; PTPN6; PIK3C2A; MAPK14; RAF1; AKT1; PIK3R1; STAT3; MAP2K1; FGFR4; CRKL; ATF4; AKT3; PRKCA; HGF
GM-CSF Signaling	LYN; ELK1; MAPK1; PTPN11; AKT2; PIK3CA; CAMK2A; STAT5B; PIK3CB; PIK3C3; GNB2L1; BCL2L1; MAPK3; ETS1; KRAS; RUNX1; PIM1; PIK3C2A; RAF1; MAP2K2; AKT1; JAK2; PIK3R1; STAT3; MAP2K1; CCND1; AKT3; STAT1
Amyotrophic Lateral Sclerosis Signaling	BID; IGF1; RAC1; BIRC4; PGF; CAPNS1; CAPN2; PIK3CA; BCL2; PIK3CB; PIK3C3; BCL2L1; CAPN1; PIK3C2A; TP53; CASP9; PIK3R1; RAB5A; CASP1; APAF1; VEGFA; BIRC2; BAX; AKT3; CASP3; BIRC3
JAK/Stat Signaling	PTPN1; MAPK1; PTPN11; AKT2; PIK3CA; STAT5B; PIK3CB; PIK3C3; MAPK3; KRAS; SOCS1; STAT5A; PTPN6; PIK3C2A; RAF1; CDKN1A; MAP2K2; JAK1; AKT1; JAK2; PIK3R1; STAT3; MAP2K1; FRAP1; AKT3; STAT1
Nicotinate and Nicotinamide Metabolism	PRKCE; IRAK1; PRKAA2; EIF2AK2; GRK6; MAPK1; PLK1; AKT2; CDK8; MAPK8; MAPK3; PRKCD; PRKAA1; PBEF1; MAPK9; CDK2; PIM1; DYRK1A; MAP2K2; MAP2K1; PAK3; NT5E; TTK; CSNK1A1; BRAF; SGK
Chemokine Signaling	CXCR4; ROCK2; MAPK1; PTK2; FOS; CFL1; GNAQ; CAMK2A; CXCL12; MAPK8; MAPK3; KRAS; MAPK13; RHOA; CCR3; SRC; PPP1CC; MAPK14; NOX1; RAF1; MAP2K2; MAP2K1; JUN; CCL2; PRKCA
IL-2 Signaling	ELK1; MAPK1; PTPN11; AKT2; PIK3CA; SYK; FOS; STAT5B; PIK3CB; PIK3C3; MAPK8; MAPK3; KRAS; SOCS1; STAT5A; PIK3C2A; LCK; RAF1; MAP2K2; JAK1; AKT1; PIK3R1; MAP2K1; JUN; AKT3
Synaptic Long Term Depression	PRKCE; IGF1; PRKCZ; PRDX6; LYN; MAPK1; GNAS; PRKCI; GNAQ; PPP2R1A; IGF1R; PRKDI; MAPK3; KRAS; GRN; PRKCD; NOS3; NOS2A; PPP2CA; YWHAZ; RAF1; MAP2K2; PPP2R5C; MAP2K1; PRKCA
Estrogen Receptor Signaling	TAF4B; EP300; CARM1; PCAF; MAPK1; NCOR2; SMARCA4; MAPK3; NRIP1; KRAS; SRC; NR3C1; HDAC3; PPARGC1A; RBM9; NCOA3; RAF1; CREBBP; MAP2K2; NCOA2; MAP2K1; PRKDC; ESR1; ESR2
Protein Ubiquitination Pathway	TRAF6; SMURF1; BIRC4; BRCA1; UCHL1; NEDD4; CBL; UBE2I; BTRC; HSPA5; USP7; USP10; FBXW7; USP9X; STUB1; USP22; B2M; BIRC2; PARK2; USP8; USP1; VHL; HSP90AA1; BIRC3
IL-10 Signaling	TRAF6; CCR1; ELK1; IKKBK; SP1; FOS; NFKB2; MAP3K14; MAPK8; MAPK13; RELA; MAPK14; TNF; IKBK; RELB; MAP3K7; JAK1; CHUK; STAT3; NFKB1; JUN; IL1R1; IL6
VDR/RXR Activation	PRKCE; EP300; PRKCZ; RXRA; GADD45A; HES1; NCOR2; SP1; PRKCI; CDKN1B; PRKDI; PRKCD; RUNX2; KLF4; YY1; NCOA3; CDKN1A; NCOA2; SPP1; LRP5; CEBPB; FOXO1; PRKCA
TGF-beta Signaling	EP300; SMAD2; SMURF1; MAPK1; SMAD3; SMAD1; FOS; MAPK8; MAPK3; KRAS; MAPK9; RUNX2; SERPINE1; RAF1; MAP3K7; CREBBP; MAP2K2; MAP2K1; TGFBRI; SMAD4; JUN; SMAD5
Toll-like Receptor Signaling	IRAK1; EIF2AK2; MYD88; TRAF6; PPARA; ELK1; IKKBK; FOS; NFKB2; MAP3K14; MAPK8; MAPK13; RELA; TLR4; MAPK14; IKBK; RELB; MAP3K7; CHUK; NFKB1; TLR2; JUN
p38 MAPK Signaling	HSPB1; IRAK1; TRAF6; MAPKAPK2; ELK1; FADD; FAS; CREB1; DDIT3; RPS6KA4; DAXX; MAPK13; TRAF2; MAPK14; TNF; MAP3K7; TGFBRI; MYC; ATF4; IL1R1; SRF; STAT1

TABLE C-continued

CELLULAR FUNCTION	GENES
Neurotrophin/TRK Signaling	NTRK2; MAPK1; PTPN11; PIK3CA; CREB1; FOS; PIK3CB; PIK3C3; MAPK8; MAPK3; KRAS; PIK3C2A; RAF1; MAP2K2; AKT1; PIK3R1; PDPK1; MAP2K1; CDC42; JUN; ATF4
FXR/RXR Activation	INS; PPARA; FASN; RXRA; AKT2; SDC1; MAPK8; APOB; MAPK10; PPARG; MTTT; MAPK9; PPARGC1A; TNF; CREBBP; AKT1; SREBF1; FGFR4; AKT3; FOXO1
Synaptic Long Term Potentiation	PRKCE; RAPIA; EP300; PRKCZ; MAPK1; CREB1; PRKCI; GNAQ; CAMK2A; PRKD1; MAPK3; KRAS; PRKCD; PPP1CC; RAF1; CREBBP; MAP2K2; MAP2K1; ATF4; PRKCA
Calcium Signaling	RAP1A; EP300; HDAC4; MAPK1; HDAC5; CREB1; CAMK2A; MYH9; MAPK3; HDAC2; HDAC7A; HDAC11; HDAC9; HDAC3; CREBBP; CALR; CAMKK2; ATF4; HDAC6
EGF Signaling	ELK1; MAPK1; EGFR; PIK3CA; FOS; PIK3CB; PIK3C3; MAPK8; MAPK3; PIK3C2A; RAF1; JAK1; PIK3R1; STAT3; MAP2K1; JUN; PRKCA; SRF; STAT1
Hypoxia Signaling in the Cardiovascular System	EDN1; PTEN; EP300; NQO1; UBE2I; CREB1; ARNT; HIF1A; SLC2A4; NOS3; TP53; LDHA; AKT1; ATM; VEGFA; JUN; ATF4; VHL; HSP90AA1
LPS/IL-1 Mediated Inhibition of RXR Function	IRAK1; MYD88; TRAF6; PPARA; RXRA; ABCA1; MAPK8; ALDH1A1; GSTP1; MAPK9; ABCB1; TRAF2; TLR4; TNF; MAP3K7; NR1H2; SREBF1; JUN; IL1R1
LXR/RXR Activation	FASN; RXRA; NCOR2; ABCA1; NFKB2; IRF3; RELA; NOS2A; TLR4; TNF; RELB; LDLR; NR1H2; NFKB1; SREBF1; IL1R1; CCL2; IL6; MMP9
Amyloid Processing	PRKCE; CSNK1E; MAPK1; CAPNS1; AKT2; CAPN2; CAPN1; MAPK3; MAPK13; MAPT; MAPK14; AKT1; PSEN1; CSNK1A1; GSK3B; AKT3; APP
IL-4 Signaling	AKT2; PIK3CA; PIK3CB; PIK3C3; IRS1; KRAS; SOCS1; PTPN6; NR3C1; PIK3C2A; JAK1; AKT1; JAK2; PIK3R1; FRAP1; AKT3; RPS6KB1
Cell Cycle: G2/M DNA Damage Checkpoint Regulation	EP300; PCAF; BRCA1; GADD45A; PLK1; BTRC; CHEK1; ATR; CHEK2; YWHAZ; TP53; CDKN1A; PRKDC; ATM; SFN; CDKN2A
Nitric Oxide Signaling in the Cardiovascular System	KDR; FLT1; PGF; AKT2; PIK3CA; PIK3CB; PIK3C3; CAV1; PRKCD; NOS3; PIK3C2A; AKT1; PIK3R1; VEGFA; AKT3; HSP90AA1
Purine Metabolism	NME2; SMARCA4; MYH9; RRM2; ADAR; EIF2AK4; PKM2; ENTPD1; RAD51; RRM2B; TJP2; RAD51C; NT5E; POLD1; NME1
cAMP-mediated Signaling	RAP1A; MAPK1; GNAS; CREB1; CAMK2A; MAPK3; SRC; RAF1; MAP2K2; STAT3; MAP2K1; BRAF; ATF4
Mitochondrial Dysfunction	SOD2; MAPK8; CASP8; MAPK10; MAPK9; CASP9; PARK7; PSEN1; PARK2; APP; CASP3
Notch Signaling	HES1; JAG1; NUMB; NOTCH4; ADAM17; NOTCH2; PSEN1; NOTCH3; NOTCH1; DLL4
Endoplasmic Reticulum Stress Pathway	HSPA5; MAPK8; XBP1; TRAF2; ATF6; CASP9; ATF4; EIF2AK3; CASP3
Pyrimidine Metabolism	NME2; AICDA; RRM2; EIF2AK4; ENTPD1; RRM2B; NT5E; POLD1; NME1
Parkinson's Signaling	UCHL1; MAPK8; MAPK13; MAPK14; CASP9; PARK7; PARK2; CASP3
Cardiac & Beta Adrenergic Signaling	GNAS; GNAQ; PPP2R1A; GNB2L1; PPP2CA; PPP1CC; PPP2R5C
Glycolysis/Gluconeogenesis	HK2; GCK; GPI; ALDH1A1; PKM2; LDHA; HK1
Interferon Signaling	IRF1; SOCS1; JAK1; JAK2; IFITM1; STAT1; IFIT3
Sonic Hedgehog Signaling	ARRB2; SMO; GLI2; DYRK1A; GLI1; GSK3B; DYRK1B
Glycerophospholipid Metabolism	PLD1; GRN; GPAM; YWHAZ; SPHK1; SPHK2
Phospholipid Degradation	PRDX6; PLD1; GRN; YWHAZ; SPHK1; SPHK2

TABLE C-continued

CELLULAR FUNCTION	GENES
Tryptophan Metabolism	SIAH2; PRMT5; NEDD4; ALDH1A1; CYP1B1; SIAH1
Lysine Degradation	SUV39H1; EHMT2; NSD1; SETD7; PPP2R5C
Nucleotide Excision Repair Pathway	ERCC5; ERCC4; XPA; XPC; ERCC1
Starch and Sucrose Metabolism	UCHL1; HK2; GCK; GPI; HK1
Aminosugars Metabolism	NQO1; HK2; GCK; HK1
Arachidonic Acid Metabolism	PRDX6; GRN; YWHAZ; CYP1B1
Circadian Rhythm Signaling	CSNK1E; CREB1; ATF4; NR1D1
Coagulation System	BDKRB1; F2R; SERPINE1; F3
Dopamine Receptor Signaling	PPP2R1A; PPP2CA; PPP1CC; PPP2R5C
Glutathione Metabolism	IDH2; GSTP1; ANPEP; IDH1
Glycerolipid Metabolism	ALDH1A1; GPAM; SPHK1; SPHK2
Linoleic Acid Metabolism	PRDX6; GRN; YWHAZ; CYP1B1
Methionine Metabolism	DNMT1; DNMT3B; AHCY; DNMT3A
Pyruvate Metabolism	GLO1; ALDH1A1; PKM2; LDHA
Arginine and Proline Metabolism	ALDH1A1; NOS3; NOS2A
Eicosanoid Signaling	PRDX6; GRN; YWHAZ
Fructose and Mannose Metabolism	HK2; GCK; HK1
Galactose Metabolism	HK2; GCK; HK1
Stilbene, Coumarine and Lignin Biosynthesis	PRDX6; PRDX1; TYR
Antigen Presentation Pathway	CALR; B2M
Biosynthesis of Steroids	NQO1; DHCR7
Butanoate Metabolism	ALDH1A1; NLGN1
Citrate Cycle	IDH2; IDH1
Fatty Acid Metabolism	ALDH1A1; CYP1B1
Glycerophospholipid Metabolism	PRDX6; CHKA
Histidine Metabolism	PRMT5; ALDH1A1
Inositol Metabolism	ERO1L; APEX1
Metabolism of Xenobiotics	GSTP1; CYP1B1
by Cytochrome p450	
Methane Metabolism	PRDX6; PRDX1
Phenylalanine Metabolism	PRDX6; PRDX1
Propanoate Metabolism	ALDH1A1; LDHA
Selenoamino Acid Metabolism	PRMT5; AHCY
Sphingolipid Metabolism	SPHK1; SPHK2
Aminophosphonate Metabolism	PRMT5
Androgen and Estrogen Metabolism	PRMT5
Ascorbate and Aldarate Metabolism	ALDH1A1
Bile Acid Biosynthesis	ALDH1A1
Cysteine Metabolism	LDHA
Fatty Acid Biosynthesis	FASN
Glutamate Receptor Signaling	GNB2L1
NRF2-mediated Oxidative Stress Response	PRDX1
Pentose Phosphate Pathway	GPI
Pentose and Glucuronate Interconversions	UCHL1
Retinol Metabolism	ALDH1A1
Riboflavin Metabolism	TYR
Tyrosine Metabolism	PRMT5; TYR
Ubiquinone Biosynthesis	PRMT5
Valine, Leucine and Isoleucine Degradation	ALDH1A1

TABLE C-continued

CELLULAR FUNCTION	GENES
Glycine, Serine and Threonine Metabolism	CHKA
Lysine Degradation	ALDH1A1
Pain/Taste	TRPM5; TRPA1
Pain	TRPM7; TRPC5; TRPC6; TRPC1; Cnr1; cnr2; Grk2; Trpa1; Pomc; Cgrp; Crf; Pka; Era; Nr2b; TRPM5; Prkaca; Prkacb; Prkar1a; Prkar2a
Mitochondrial Function	AIF; CytC; SMAC (Diablo); Aifm-1; Aifm-2
Developmental Neurology	BMP-4; Chordin (Chrd); Noggin (Nog); WNT (Wnt2; Wnt2b; Wnt3a; Wnt4; Wnt5a; Wnt6; Wnt7b; Wnt8b; Wnt9a; Wnt9b; Wnt10a; Wnt10b; Wnt16); beta-catenin; Dkk-1; Frizzled related proteins; Otx-2; Gbx2; FGF-8; Reelin; Dab1; unc-86 (Pou4f1 or Brn3a); Numb; Reln

[0162] Embodiments of the invention also relate to methods and compositions related to knocking out genes, amplifying genes and repairing particular mutations associated with DNA repeat instability and neurological disorders (Robert D. Wells, Tetsuo Ashizawa, Genetic Instabilities and Neurological Diseases, Second Edition, Academic Press, Oct. 13, 2011—Medical). Specific aspects of tandem repeat sequences have been found to be responsible for more than twenty human diseases (New insights into repeat instability: role of RNA*DNA hybrids. McIvor E I, Polak U, Napierala M. RNA Biol. 2010 September-October; 7(5):551-8). The CRISPR-Cas system may be harnessed to correct these defects of genomic instability.

[0163] A further aspect of the invention relates to utilizing the CRISPR-Cas system for correcting defects in the EMP2A and EMP2B genes that have been identified to be associated with Lafora disease. Lafora disease is an autosomal recessive condition which is characterized by progressive myoclonus epilepsy which may start as epileptic seizures in adolescence. A few cases of the disease may be caused by mutations in genes yet to be identified. The disease causes seizures, muscle spasms, difficulty walking, dementia, and eventually death. There is currently no therapy that has proven effective against disease progression. Other genetic abnormalities associated with epilepsy may also be targeted by the CRISPR-Cas system and the underlying genetics is further described in Genetics of Epilepsy and Genetic Epilepsies, edited by Giuliano Avanzini, Jeffrey L. Noebels, Mariani Foundation Paediatric Neurology:20; 2009).

[0164] In yet another aspect of the invention, the CRISPR-Cas system may be used to correct ocular defects that arise from several genetic mutations further described in Genetic Diseases of the Eye, Second Edition, edited by Elias I. Traboulsi, Oxford University Press, 2012.

[0165] Several further aspects of the invention relate to correcting defects associated with a wide range of genetic diseases which are further described on the website of the National Institutes of Health under the topic subsection Genetic Disorders (website at health.nih.gov/topic/GeneticDisorders). The genetic brain diseases may include but are not limited to Adrenoleukodystrophy, Agenesis of the Corpus Callosum, Aicardi Syndrome, Alpers' Disease, Alzheimer's Disease, Barth Syndrome, Batten Disease, CADASIL, Cerebellar Degeneration, Fabry's Disease, Gerstmann-Straussler-Scheinker Disease, Huntington's Disease and

other Triplet Repeat Disorders, Leigh's Disease, Lesch-Nyhan Syndrome, Menkes Disease, Mitochondrial Myopathies and NINDS Colpocephaly. These diseases are further described on the website of the National Institutes of Health under the subsection Genetic Brain Disorders.

[0166] In some embodiments, the condition may be neoplasia. In some embodiments, where the condition is neoplasia, the genes to be targeted are any of those listed in Table A (in this case PTEN and so forth). In some embodiments, the condition may be Age-related Macular Degeneration. In some embodiments, the condition may be a Schizophrenic Disorder. In some embodiments, the condition may be a Trinucleotide Repeat Disorder. In some embodiments, the condition may be Fragile X Syndrome. In some embodiments, the condition may be a Secretase Related Disorder. In some embodiments, the condition may be a Prion-related disorder. In some embodiments, the condition may be ALS. In some embodiments, the condition may be a drug addiction. In some embodiments, the condition may be Autism. In some embodiments, the condition may be Alzheimer's Disease. In some embodiments, the condition may be inflammation. In some embodiments, the condition may be Parkinson's Disease.

[0167] Examples of proteins associated with Parkinson's disease include but are not limited to α -synuclein, DJ-1, LRRK2, PINK1, Parkin, UCHL1, Synphilin-1, and NURR1.

[0168] Examples of addiction-related proteins may include ABAT for example.

[0169] Examples of inflammation-related proteins may include the monocyte chemoattractant protein-1 (MCP1) encoded by the Ccr2 gene, the C-C chemokine receptor type 5 (CCR5) encoded by the Ccr5 gene, the IgG receptor IIB (FCGR2b, also termed CD32) encoded by the Fcgr2b gene, or the Fc epsilon R1g (FCER1g) protein encoded by the Fcer1g gene, for example.

[0170] Examples of cardiovascular diseases associated proteins may include IL1B (interleukin 1, beta), XDH (xanthine dehydrogenase), TP53 (tumor protein p53), PTGIS (prostaglandin 12 (prostacyclin) synthase), MB (myoglobin), IL4 (interleukin 4), ANGPT1 (angiopoietin 1), ABCG8 (ATP-binding cassette, sub-family G (WHITE), member 8), or CTSK (cathepsin K), for example.

[0171] Examples of Alzheimer's disease associated proteins may include the very low density lipoprotein receptor protein (VLDLR) encoded by the VLDLR gene, the ubiquitin-like modifier activating enzyme 1 (UBA1) encoded by

the UBA1 gene, or the NEDD8-activating enzyme E1 catalytic subunit protein (UBE1C) encoded by the UBA3 gene, for example.

[0172] Examples of proteins associated Autism Spectrum Disorder may include the benzodiazepine receptor (peripheral) associated protein 1 (BZRAP1) encoded by the BZRAP1 gene, the AF4/FMR2 family member 2 protein (AFF2) encoded by the AFF2 gene (also termed MFR2), the fragile X mental retardation autosomal homolog 1 protein (FXR1) encoded by the FXR1 gene, or the fragile X mental retardation autosomal homolog 2 protein (FXR2) encoded by the FXR2 gene, for example.

[0173] Examples of proteins associated Macular Degeneration may include the ATP-binding cassette, sub-family A (ABC1) member 4 protein (ABCA4) encoded by the ABCR gene, the apolipoprotein E protein (APOE) encoded by the APOE gene, or the chemokine (C-C motif) Ligand 2 protein (CCL2) encoded by the CCL2 gene, for example.

[0174] Examples of proteins associated Schizophrenia may include NRG1, ErbB4, CPLX1, TPH1, TPH2, NRXN1, GSK3A, BDNF, DISC1, GSK3B, and combinations thereof.

[0175] Examples of proteins involved in tumor suppression may include ATM (ataxia telangiectasia mutated), ATR (ataxia telangiectasia and Rad3 related), EGFR (epidermal growth factor receptor), ERBB2 (v-erb-b2 erythroblastic leukemia viral oncogene homolog 2), ERBB3 (v-erb-b2 erythroblastic leukemia viral oncogene homolog 3), ERBB4 (v-erb-b2 erythroblastic leukemia viral oncogene homolog 4), Notch 1, Notch2, Notch 3, or Notch 4, for example.

[0176] Examples of proteins associated with a secretase disorder may include PSENEN (presenilin enhancer 2 homolog (*C. elegans*)), CTSB (cathepsin B), PSEN1 (presenilin 1), APP (amyloid beta (A4) precursor protein), APH1B (anterior pharynx defective 1 homolog B (*C. elegans*)), PSEN2 (presenilin 2 (Alzheimer disease 4)), or BACE1 (beta-site APP-cleaving enzyme 1), for example.

[0177] Examples of proteins associated with Amyotrophic Lateral Sclerosis may include SOD1 (superoxide dismutase 1), ALS2 (amyotrophic lateral sclerosis 2), FUS (fused in sarcoma), TARDBP (TAR DNA binding protein), VAGFA (vascular endothelial growth factor A), VAGFB (vascular endothelial growth factor B), and VAGFC (vascular endothelial growth factor C), and any combination thereof.

[0178] Examples of proteins associated with prion diseases may include SOD1 (superoxide dismutase 1), ALS2 (amyotrophic lateral sclerosis 2), FUS (fused in sarcoma), TARDBP (TAR DNA binding protein), VAGFA (vascular endothelial growth factor A), VAGFB (vascular endothelial growth factor B), and VAGFC (vascular endothelial growth factor C), and any combination thereof.

[0179] Examples of proteins related to neurodegenerative conditions in prion disorders may include A2M (Alpha-2-Macroglobulin), AAF1 (Apoptosis antagonizing transcription factor), ACPP (Acid phosphatase prostate), ACTA2 (Actin alpha 2 smooth muscle aorta), ADAM22 (ADAM metalloproteinase domain), ADORA3 (Adenosine A3 receptor), or ADRA1D (Alpha-1D adrenergic receptor for Alpha-1D adrenoreceptor), for example.

[0180] Examples of proteins associated with Immunodeficiency may include A2M [alpha-2-macroglobulin]; AANAT [arylalkylamine N-acetyltransferase]; ABCA1 [ATP-binding cassette, sub-family A (ABC1), member 1]; ABCA2 [ATP-binding cassette, sub-family A (ABC1),

member 2]; or ABCA3 [ATP-binding cassette, sub-family A (ABC1), member 3]; for example.

[0181] Examples of proteins associated with Trinucleotide Repeat Disorders include AR (androgen receptor), FMR1 (fragile X mental retardation 1), HTT (huntingtin), or DMPK (dystrophia myotonica-protein kinase), FXN (frataxin), ATXN2 (ataxin 2), for example.

[0182] Examples of proteins associated with Neurotransmission Disorders include SST (somatostatin), NOS1 (nitric oxide synthase 1 (neuronal)), ADRA2A (adrenergic, alpha-2A-, receptor), ADRA2C (adrenergic, alpha-2C-, receptor), TACR1 (tachykinin receptor 1), or HTR2c (5-hydroxytryptamine (serotonin) receptor 2C), for example.

[0183] Examples of neurodevelopmental-associated sequences include A2BP1 [ataxin 2-binding protein 1], AADAT [aminoacidase aminotransferase], AANAT [arylalkylamine N-acetyltransferase], ABAT [4-aminobutyrate aminotransferase], ABCA1 [ATP-binding cassette, sub-family A (ABC1), member 1], or ABCA13 [ATP-binding cassette, sub-family A (ABC1), member 13], for example.

[0184] Further examples of preferred conditions treatable with the present system include may be selected from: Aicardi-Goutières Syndrome; Alexander Disease; Allan-Herndon-Dudley Syndrome; POLG-Related Disorders; Alpha-Mannosidosis (Type II and III); Alström Syndrome; Angelman; Syndrome; Ataxia-Telangiectasia; Neuronal Ceroid-Lipofuscinoses; Beta-Thalassemia; Bilateral Optic Atrophy and (Infantile) Optic Atrophy Type 1; Retinoblastoma (bilateral); Canavan Disease; Cerebrooculofacioskeletal Syndrome 1 [COFS1]; Cerebrotendinous Xanthomatosis; Cornelia de Lange Syndrome; MAPT-Related Disorders; Genetic Prion Diseases; Dravet Syndrome; Early-Onset Familial Alzheimer Disease; Friedreich Ataxia [FRDA]; Fryns Syndrome; Fucosidosis; Fukuyama Congenital Muscular Dystrophy; Galactosialidosis; Gaucher Disease; Organic Acidemias; Hemophagocytic Lymphohistiocytosis; Hutchinson-Gilford Progeria Syndrome; Mucopolipidosis II; Infantile Free Sialic Acid Storage Disease; PLA2G6-Associated Neurodegeneration; Jervell and Lange-Nielsen Syndrome; Junctional Epidermolysis Bullosa; Huntington Disease; Krabbe Disease (Infantile); Mitochondrial DNA-Associated Leigh Syndrome and NARP; Lesch-Nyhan Syndrome; LIS1-Associated Lissencephaly; Lowe Syndrome; Maple Syrup Urine Disease; MECP2 Duplication Syndrome; ATP7A-Related Copper Transport Disorders; LAMA2-Related Muscular Dystrophy; Arylsulfatase A Deficiency; Mucopolysaccharidosis Types I, II or III; Peroxisome Biogenesis Disorders, Zellweger Syndrome Spectrum; Neurodegeneration with Brain Iron Accumulation Disorders; Acid Sphingomyelinase Deficiency; Niemann-Pick Disease Type C; Glycine Encephalopathy; ARX-Related Disorders; Urea Cycle Disorders; COL1A1/2-Related Osteogenesis Imperfecta; Mitochondrial DNA Deletion Syndromes; PLP1-Related Disorders; Perry Syndrome; Phelan-McDermid Syndrome; Glycogen Storage Disease Type II (Pompe Disease) (Infantile); MAPT-Related Disorders; MECP2-Related Disorders; Rhizomelic Chondrodysplasia Punctata Type 1; Roberts Syndrome; Sandhoff Disease; Schindler Disease—Type 1; Adenosine Deaminase Deficiency; Smith-Lemli-Opitz Syndrome; Spinal Muscular Atrophy; Infantile-Onset Spinocerebellar Ataxia; Hexosaminidase A Deficiency; Thanatophoric Dysplasia Type 1; Collagen Type VI-Related Disorders; Usher Syndrome Type I; Congenital Muscular Dystrophy; Wolf-

Hirschhorn Syndrome; Lysosomal Acid Lipase Deficiency; and Xeroderma Pigmentosum.

[0185] As will be apparent, it is envisaged that the present system can be used to target any polynucleotide sequence of interest. Some examples of conditions or diseases that might be usefully treated using the present system are included in the Tables above and examples of genes currently associated with those conditions are also provided there. However, the genes exemplified are not exhaustive.

EXAMPLES

[0186] The following examples are given for the purpose of illustrating various embodiments of the invention and are not meant to limit the present invention in any fashion. The present examples, along with the methods described herein are presently representative of preferred embodiments, are exemplary, and are not intended as limitations on the scope of the invention. Changes therein and other uses which are encompassed within the spirit of the invention as defined by the scope of the claims will occur to those skilled in the art.

Example 1: CRISPR Complex Activity in the Nucleus of a Eukaryotic Cell

[0187] An example type II CRISPR system is the type II CRISPR locus from *Streptococcus pyogenes* SF370, which contains a cluster of four genes Cas9, Cas1, Cas2, and Csn1, as well as two non-coding RNA elements, tracrRNA and a characteristic array of repetitive sequences (direct repeats) interspaced by short stretches of non-repetitive sequences (spacers, about 30 bp each). In this system, targeted DNA double-strand break (DSB) is generated in four sequential steps (FIG. 2A). First, two non-coding RNAs, the pre-crRNA array and tracrRNA, are transcribed from the CRISPR locus. Second, tracrRNA hybridizes to the direct repeats of pre-crRNA, which is then processed into mature crRNAs containing individual spacer sequences. Third, the mature crRNA:tracrRNA complex directs Cas9 to the DNA target consisting of the protospacer and the corresponding PAM via heteroduplex formation between the spacer region of the crRNA and the protospacer DNA. Finally, Cas9 mediates cleavage of target DNA upstream of PAM to create a DSB within the protospacer (FIG. 2A). This example describes an example process for adapting this RNA-programmable nuclease system to direct CRISPR complex activity in the nuclei of eukaryotic cells.

[0188] Cell Culture and Transfection

[0189] Human embryonic kidney (HEK) cell line HEK 293FT (Life Technologies) was maintained in Dulbecco's modified Eagle's Medium (DMEM) supplemented with 10% fetal bovine serum (HyClone), 2 mM GlutaMAX (Life Technologies), 100 U/mL penicillin, and 100 g/mL streptomycin at 37° C. with 5% CO₂ incubation. Mouse neuro2A (N2A) cell line (ATCC) was maintained with DMEM supplemented with 5% fetal bovine serum (HyClone), 2 mM GlutaMAX (Life Technologies), 100 U/mL penicillin, and 100 g/mL streptomycin at 37° C. with 5% CO₂.

[0190] HEK 293FT or N2A cells were seeded into 24-well plates (Corning) one day prior to transfection at a density of 200,000 cells per well. Cells were transfected using Lipofectamine 2000 (Life Technologies) following the manufacturer's recommended protocol. For each well of a 24-well plate a total of 800 ng of plasmids were used.

[0191] Surveyor Assay and Sequencing Analysis for Genome Modification

[0192] HEK 293FT or N2A cells were transfected with plasmid DNA as described above. After transfection, the cells were incubated at 37° C. for 72 hours before genomic DNA extraction. Genomic DNA was extracted using the QuickExtract DNA extraction kit (Epicentre) following the manufacturer's protocol. Briefly, cells were resuspended in QuickExtract solution and incubated at 65° C. for 15 minutes and 98° C. for 10 minutes. Extracted genomic DNA was immediately processed or stored at -20° C.

[0193] The genomic region surrounding a CRISPR target site for each gene was PCR amplified, and products were purified using QiaQuick Spin Column (Qiagen) following manufacturer's protocol. A total of 400 ng of the purified PCR products were mixed with 2 µl 10× Taq polymerase PCR buffer (Enzymatics) and ultrapure water to a final volume of 20 µl, and subjected to a re-annealing process to enable heteroduplex formation: 95° C. for 10 min, 95° C. to 85° C. ramping at -2° C./s, 85° C. to 25° C. at -0.25° C./s, and 25° C. hold for 1 minute. After re-annealing, products were treated with Surveyor nuclease and Surveyor enhancer S (Transgenomics) following the manufacturer's recommended protocol, and analyzed on 4-20% Novex TBE poly-acrylamide gels (Life Technologies). Gels were stained with SYBR Gold DNA stain (Life Technologies) for 30 minutes and imaged with a Gel Doc gel imaging system (Bio-rad). Quantification was based on relative band intensities, as a measure of the fraction of cleaved DNA. FIG. 8 provides a schematic illustration of this Surveyor assay.

[0194] Restriction Fragment Length Polymorphism Assay for Detection of Homologous Recombination

[0195] HEK 293FT and N2A cells were transfected with plasmid DNA, and incubated at 37° C. for 72 hours before genomic DNA extraction as described above. The target genomic region was PCR amplified using primers outside the homology arms of the homologous recombination (HR) template. PCR products were separated on a 1% agarose gel and extracted with MinElute GelExtraction Kit (Qiagen). Purified products were digested with HindIII (Fermentas) and analyzed on a 6% Novex TBE poly-acrylamide gel (Life Technologies).

[0196] RNA Secondary Structure Prediction and Analysis

[0197] RNA secondary structure prediction was performed using the online webserver RNAfold developed at Institute for Theoretical Chemistry at the University of Vienna, using the centroid structure prediction algorithm (see e.g. A. R. Gruber et al., 2008, Cell 106(1): 23-24; and PA Carr and GM Church, 2009, Nature Biotechnology 27(12): 1151-62).

[0198] Bacterial Plasmid Transformation Interference Assay

[0199] Elements of the *S. pyogenes* CRISPR locus 1 sufficient for CRISPR activity were reconstituted in *E. coli* using pCRISPR plasmid (schematically illustrated in FIG. 10A). pCRISPR contained tracrRNA, SpCas9, and a leader sequence driving the crRNA array. Spacers (also referred to as "guide sequences") were inserted into the crRNA array between BsaI sites using annealed oligonucleotides, as illustrated. Challenge plasmids used in the interference assay were constructed by inserting the protospacer (also referred to as a "target sequence") sequence along with an adjacent CRISPR motif sequence (PAM) into pUC19 (see FIG. 10B). The challenge plasmid contained ampicillin resistance. FIG.

10C provides a schematic representation of the interference assay. Chemically competent *E. coli* strains already carrying pCRISPR and the appropriate spacer were transformed with the challenge plasmid containing the corresponding protospacer-PAM sequence. pUC19 was used to assess the transformation efficiency of each pCRISPR-carrying competent strain. CRISPR activity resulted in cleavage of the pPSP plasmid carrying the protospacer, precluding ampicillin resistance otherwise conferred by pUC19 lacking the protospacer. FIG. 10D illustrates competence of each pCRISPR-carrying *E. coli* strain used in assays illustrated in FIG. 4C.

[0200] RNA Purification

[0201] HEK 293FT cells were maintained and transfected as stated above. Cells were harvested by trypsinization followed by washing in phosphate buffered saline (PBS). Total cell RNA was extracted with TRI reagent (Sigma) following manufacturer's protocol. Extracted total RNA was quantified using Naonodrop (Thermo Scientific) and normalized to same concentration.

[0202] Northern Blot Analysis of crRNA and tracrRNA Expression in Mammalian Cells

[0203] RNAs were mixed with equal volumes of 2× loading buffer (Ambion), heated to 95° C. for 5 min, chilled on ice for 1 min, and then loaded onto 8% denaturing polyacrylamide gels (SequaGel, National Diagnostics) after pre-running the gel for at least 30 minutes. The samples were electrophoresed for 1.5 hours at 40 W limit. Afterwards, the RNA was transferred to Hybond N+ membrane (GE Healthcare) at 300 mA in a semi-dry transfer apparatus (Bio-rad) at room temperature for 1.5 hours. The RNA was crosslinked to the membrane using autocrosslink button on Stratagene UV Crosslinker the Stratalink (Stratagene). The membrane was pre-hybridized in ULTRAhyb-Oligo Hybridization Buffer (Ambion) for 30 min with rotation at 42° C., and probes were then added and hybridized overnight. Probes were ordered from IDT and labeled with [γ -³²P] ATP (Perkin Elmer) with T4 polynucleotide kinase (New England Biolabs). The membrane was washed once with pre-warmed (42° C.) 2×SSC, 0.5% SDS for 1 min followed by two 30 minute washes at 42° C. The membrane was exposed to a phosphor screen for one hour or overnight at room temperature and then scanned with a phosphorimager (Typhoon).

[0204] Bacterial CRISPR System Construction and Evaluation

[0205] CRISPR locus elements, including tracrRNA, Cas9, and leader were PCR amplified from *Streptococcus pyogenes* SF370 genomic DNA with flanking homology arms for Gibson Assembly. Two BsaI type IIS sites were introduced in between two direct repeats to facilitate easy insertion of spacers (FIG. 9). PCR products were cloned into EcoRV-digested pACYC184 downstream of the tet promoter using Gibson Assembly Master Mix (NEB). Other endogenous CRISPR system elements were omitted, with the exception of the last 50 bp of Csn2. Oligos (Integrated DNA Technology) encoding spacers with complimentary overhangs were cloned into the BsaI-digested vector pDC000 (NEB) and then ligated with T7 ligase (Enzymatics) to generate pCRISPR plasmids. Challenge plasmids containing spacers with PAM sequences (also referred to herein as "CRISPR motif sequences") were created by ligating hybridized oligos carrying compatible overhangs

(Integrated DNA Technology) into BamHI-digested pUC19. Cloning for all constructs was performed in *E. coli* strain JM109 (Zymo Research).

[0206] pCRISPR-carrying cells were made competent using the Z-Competent *E. coli* Transformation Kit and Buffer Set (Zymo Research, T3001) according to manufacturer's instructions. In the transformation assay, 50 μ L aliquots of competent cells carrying pCRISPR were thawed on ice and transformed with 1 ng of spacer plasmid or pUC19 on ice for 30 minutes, followed by 45 second heat shock at 42° C. and 2 minutes on ice. Subsequently, 250 μ L SOC (Invitrogen) was added followed by shaking incubation at 37° C. for 1 hr, and 100 μ L of the post-SOC outgrowth was plated onto double selection plates (12.5 μ g/ml chloramphenicol, 100 μ g/ml ampicillin). To obtain cfu/ng of DNA, total colony numbers were multiplied by 3.

[0207] To improve expression of CRISPR components in mammalian cells, two genes from the SF370 locus 1 of *Streptococcus pyogenes* (*S. pyogenes*) were codon-optimized, Cas9 (SpCas9) and RNase III (SpRNase III). To facilitate nuclear localization, a nuclear localization signal (NLS) was included at the amino (N)- or carboxyl (C)-termini of both SpCas9 and SpRNase III (FIG. 2B). To facilitate visualization of protein expression, a fluorescent protein marker was also included at the N- or C-termini of both proteins (FIG. 2B). A version of SpCas9 with an NLS attached to both N- and C-termini (2×NLS-SpCas9) was also generated. Constructs containing NLS-fused SpCas9 and SpRNase III were transfected into 293FT human embryonic kidney (HEK) cells, and the relative positioning of the NLS to SpCas9 and SpRNase III was found to affect their nuclear localization efficiency. Whereas the C-terminal NLS was sufficient to target SpRNase III to the nucleus, attachment of a single copy of these particular NLS's to either the N- or C-terminus of SpCas9 was unable to achieve adequate nuclear localization in this system. In this example, the C-terminal NLS was that of nucleoplasmin (KRPAATKK-AGQAKKKK (SEQ ID NO: 2)), and the C-terminal NLS was that of the SV40 large T-antigen (PKKKRKV (SEQ ID NO: 1)). Of the versions of SpCas9 tested, only 2×NLS-SpCas9 exhibited nuclear localization (FIG. 2B).

[0208] The tracrRNA from the CRISPR locus of *S. pyogenes* SF370 has two transcriptional start sites, giving rise to two transcripts of 89-nucleotides (nt) and 171 nt that are subsequently processed into identical 75 nt mature tracrRNAs. The shorter 89 nt tracrRNA was selected for expression in mammalian cells (expression constructs illustrated in FIG. 7A, with functionality as determined by results of the Surveyor assay shown in FIG. 7B). Transcription start sites are marked as +1, and transcription terminator and the sequence probed by northern blot are also indicated. Expression of processed tracrRNA was also confirmed by Northern blot. FIG. 7C shows results of a Northern blot analysis of total RNA extracted from 293FT cells transfected with U6 expression constructs carrying long or short tracrRNA, as well as SpCas9 and DR-EMX1(1)-DR. Left and right panels are from 293FT cells transfected without or with SpRNase III, respectively. U6 indicate loading control blotted with a probe targeting human U6 snRNA. Transfection of the short tracrRNA expression construct led to abundant levels of the processed form of tracrRNA (~75 bp). Very low amounts of long tracrRNA are detected on the Northern blot.

[0209] To promote precise transcriptional initiation, the RNA polymerase III-based U6 promoter was selected to

drive the expression of tracrRNA (FIG. 2C). Similarly, a U6 promoter-based construct was developed to express a pre-crRNA array consisting of a single spacer flanked by two direct repeats (DRs, also encompassed by the term “tracr-mate sequences”; FIG. 2C). The initial spacer was designed to target a 33-base-pair (bp) target site (30-bp protospacer plus a 3-bp CRISPR motif (PAM) sequence satisfying the NGG recognition motif of Cas9) in the human EMX1 locus (FIG. 2C), a key gene in the development of the cerebral cortex.

[0210] To test whether heterologous expression of the CRISPR system (SpCas9, SpRNase III, tracrRNA, and pre-crRNA) in mammalian cells can achieve targeted cleavage of mammalian chromosomes, HEK 293FT cells were transfected with combinations of CRISPR components. Since DSBs in mammalian nuclei are partially repaired by the non-homologous end joining (NHEJ) pathway, which leads to the formation of indels, the Surveyor assay was used to detect potential cleavage activity at the target EMX1 locus (FIG. 8) (see e.g. Guschin et al., 2010, *Methods Mol Biol* 649: 247). Co-transfection of all four CRISPR components was able to induce up to 5.0% cleavage in the protospacer (see FIG. 2D). Co-transfection of all CRISPR components minus SpRNase III also induced up to 4.7% indel in the protospacer, suggesting that there may be endogenous mammalian RNases that are capable of assisting with crRNA maturation, such as for example the related Dicer and Drosha enzymes. Removing any of the remaining three components abolished the genome cleavage activity of the CRISPR system (FIG. 2D). Sanger sequencing of amplicons containing the target locus verified the cleavage activity: in 43 sequenced clones, 5 mutated alleles (11.6%) were found. Similar experiments using a variety of guide sequences produced indel percentages as high as 29% (see FIGS. 4-7, 12, and 13). These results define a three-component system for efficient CRISPR-mediated genome modification in mammalian cells. To optimize the cleavage efficiency, Applicants also tested whether different isoforms of tracrRNA affected the cleavage efficiency and found that, in this example system, only the short (89-bp) transcript form was able to mediate cleavage of the human EMX1 genomic locus (FIG. 7B).

[0211] FIG. 14 provides an additional Northern blot analysis of crRNA processing in mammalian cells. FIG. 14A illustrates a schematic showing the expression vector for a single spacer flanked by two direct repeats (DR-EMX1(1)-DR). The 30 bp spacer targeting the human EMX1 locus protospacer 1 (see FIG. 6) and the direct repeat sequences are shown in the sequence beneath FIG. 14A. The line indicates the region whose reverse-complement sequence was used to generate Northern blot probes for EMX1(1) crRNA detection. FIG. 14B shows a Northern blot analysis of total RNA extracted from 293FT cells transfected with U6 expression constructs carrying DR-EMX1(1)-DR. Left and right panels are from 293FT cells transfected without or with SpRNase III respectively. DR-EMX1(1)-DR was processed into mature crRNAs only in the presence of SpCas9 and short tracrRNA and was not dependent on the presence of SpRNase III. The mature crRNA detected from transfected 293FT total RNA is ~33 bp and is shorter than the 39-42 bp mature crRNA from *S. pyogenes*. These results demonstrate that a CRISPR system can be transplanted into eukaryotic cells and reprogrammed to facilitate cleavage of endogenous mammalian target polynucleotides.

[0212] FIG. 2 illustrates the bacterial CRISPR system described in this example. FIG. 2A illustrates a schematic showing the CRISPR locus 1 from *Streptococcus pyogenes* SF370 and a proposed mechanism of CRISPR-mediated DNA cleavage by this system. Mature crRNA processed from the direct repeat-spacer array directs Cas9 to genomic targets consisting of complimentary protospacers and a protospacer-adjacent motif (PAM). Upon target-spacer base pairing, Cas9 mediates a double-strand break in the target DNA. FIG. 2B illustrates engineering of *S. pyogenes* Cas9 (SpCas9) and RNase III (SpRNase III) with nuclear localization signals (NLSs) to enable import into the mammalian nucleus. FIG. 2C illustrates mammalian expression of SpCas9 and SpRNase III driven by the constitutive EF1 α promoter and tracrRNA and pre-crRNA array (DR-Spacer-DR) driven by the RNA Pol3 promoter U6 to promote precise transcription initiation and termination. A protospacer from the human EMX1 locus with a satisfactory PAM sequence is used as the spacer in the pre-crRNA array. FIG. 2D illustrates surveyor nuclease assay for SpCas9-mediated minor insertions and deletions. SpCas9 was expressed with and without SpRNase III, tracrRNA, and a pre-crRNA array carrying the EMX1-target spacer. FIG. 2E illustrates a schematic representation of base pairing between target locus and EMX1-targeting crRNA, as well as an example chromatogram showing a micro deletion adjacent to the SpCas9 cleavage site. FIG. 2F illustrates mutated alleles identified from sequencing analysis of 43 clonal amplicons showing a variety of micro insertions and deletions. Dashes indicate deleted bases, and non-aligned or mismatched bases indicate insertions or mutations. Scale bar=10 μ m.

[0213] To further simplify the three-component system, a chimeric crRNA-tracrRNA hybrid design was adapted, where a mature crRNA (comprising a guide sequence) is fused to a partial tracrRNA via a stem-loop to mimic the natural crRNA:tracrRNA duplex (FIG. 3A). To increase co-delivery efficiency, a bicistronic expression vector was created to drive co-expression of a chimeric RNA and SpCas9 in transfected cells (FIGS. 3A and 8). In parallel, the bicistronic vectors were used to express a pre-crRNA (DR-guide sequence-DR) with SpCas9, to induce processing into crRNA with a separately expressed tracrRNA (compare FIG. 13B top and bottom). FIG. 9 provides schematic illustrations of bicistronic expression vectors for pre-crRNA array (FIG. 9A) or chimeric crRNA (represented by the short line downstream of the guide sequence insertion site and upstream of the EF1 α promoter in FIG. 9B) with hSpCas9, showing location of various elements and the point of guide sequence insertion. The expanded sequence around the location of the guide sequence insertion site in FIG. 9B also shows a partial DR sequence (GTTTTAGAGCTA (SEQ ID NO: 27)) and a partial tracrRNA sequence (TAGCAAGT-TAAAATAAGGCTAGTCCGTTTTT (SEQ ID NO: 28)). Guide sequences can be inserted between BbsI sites using annealed oligonucleotides. Sequence design for the oligonucleotides are shown below the schematic illustrations in FIG. 9, with appropriate ligation adapters indicated. WPRE represents the Woodchuck hepatitis virus post-transcriptional regulatory element. The efficiency of chimeric RNA-mediated cleavage was tested by targeting the same EMX1 locus described above. Using both Surveyor assay and Sanger sequencing of amplicons, Applicants confirmed that

the chimeric RNA design facilitates cleavage of human EMX1 locus with approximately a 4.7% modification rate (FIG. 4).

[0214] Generalizability of CRISPR-mediated cleavage in eukaryotic cells was tested by targeting additional genomic loci in both human and mouse cells by designing chimeric RNA targeting multiple sites in the human EMX1 and PVALB, as well as the mouse Th loci. FIG. 15 illustrates the selection of some additional targeted protospacers in human PVALB (FIG. 15A) and mouse Th (FIG. 15B) loci. Schematics of the gene loci and the location of three protospacers within the last exon of each are provided. The underlined sequences include 30 bp of protospacer sequence and 3 bp at the 3' end corresponding to the PAM sequences. Protospacers on the sense and anti-sense strands are indicated above and below the DNA sequences, respectively. A modification rate of 6.3% and 0.75% was achieved for the human PVALB and mouse Th loci respectively, demonstrating the broad applicability of the CRISPR system in modifying different loci across multiple organisms (FIGS. 3B and 6). While cleavage was only detected with one out of three spacers for each locus using the chimeric constructs, all target sequences were cleaved with efficiency of indel production reaching 27% when using the co-expressed pre-crRNA arrangement (FIG. 6).

[0215] FIG. 13 provides a further illustration that SpCas9 can be reprogrammed to target multiple genomic loci in mammalian cells. FIG. 13A provides a schematic of the human EMX1 locus showing the location of five protospacers, indicated by the underlined sequences. FIG. 13B provides a schematic of the pre-crRNA/tracrRNA complex showing hybridization between the direct repeat region of the pre-crRNA and tracrRNA (top), and a schematic of a chimeric RNA design comprising a 20 bp guide sequence, and tracr mate and tracr sequences consisting of partial direct repeat and tracrRNA sequences hybridized in a hairpin structure (bottom). Results of a Surveyor assay comparing the efficacy of Cas9-mediated cleavage at five protospacers in the human EMX1 locus is illustrated in FIG. 13C. Each protospacer is targeted using either processed pre-crRNA/tracrRNA complex (crRNA) or chimeric RNA (chiRNA).

[0216] Since the secondary structure of RNA can be crucial for intermolecular interactions, a structure prediction algorithm based on minimum free energy and Boltzmann-weighted structure ensemble was used to compare the putative secondary structure of all guide sequences used in our genome targeting experiment (FIG. 3B) (see e.g. Gruber et al., 2008, *Nucleic Acids Research*, 36: W70). Analysis revealed that in most cases, the effective guide sequences in the chimeric crRNA context were substantially free of secondary structure motifs, whereas the ineffective guide sequences were more likely to form internal secondary structures that could prevent base pairing with the target protospacer DNA. It is thus possible that variability in the spacer secondary structure might impact the efficiency of CRISPR-mediated interference when using a chimeric crRNA.

[0217] FIG. 3 illustrates example expression vectors. FIG. 3A provides a schematic of a bi-cistronic vector for driving the expression of a synthetic crRNA-tracrRNA chimera (chimeric RNA) as well as SpCas9. The chimeric guide RNA contains a 20-bp guide sequence corresponding to the protospacer in the genomic target site. FIG. 3B provides a

schematic showing guide sequences targeting the human EMX1, PVALB, and mouse Th loci, as well as their predicted secondary structures. The modification efficiency at each target site is indicated below the RNA secondary structure drawing (EMX1, n=216 amplicon sequencing reads; PVALB, n=224 reads; Th, n=265 reads). The folding algorithm produced an output with each base colored according to its probability of assuming the predicted secondary structure, as indicated by a rainbow scale that is reproduced in FIG. 3B in gray scale. Further vector designs for SpCas9 are shown in FIG. 44, which illustrates single expression vectors incorporating a U6 promoter linked to an insertion site for a guide oligo, and a Cbh promoter linked to SpCas9 coding sequence. The vector shown in FIG. 44b includes a tracrRNA coding sequence linked to an H1 promoter.

[0218] To test whether spacers containing secondary structures are able to function in prokaryotic cells where CRISPRs naturally operate, transformation interference of protospacer-bearing plasmids were tested in an *E. coli* strain heterologously expressing the *S. pyogenes* SF370 CRISPR locus 1 (FIG. 10). The CRISPR locus was cloned into a low-copy *E. coli* expression vector and the crRNA array was replaced with a single spacer flanked by a pair of DRs (pCRISPR). *E. coli* strains harboring different pCRISPR plasmids were transformed with challenge plasmids containing the corresponding protospacer and PAM sequences (FIG. 10C). In the bacterial assay, all spacers facilitated efficient CRISPR interference (FIG. 4C). These results suggest that there may be additional factors affecting the efficiency of CRISPR activity in mammalian cells.

[0219] To investigate the specificity of CRISPR-mediated cleavage, the effect of single-nucleotide mutations in the guide sequence on protospacer cleavage in the mammalian genome was analyzed using a series of EMX1-targeting chimeric crRNAs with single point mutations (FIG. 4A). FIG. 4B illustrates results of a Surveyor nuclease assay comparing the cleavage efficiency of Cas9 when paired with different mutant chimeric RNAs. Single-base mismatch up to 12-bp 5' of the PAM substantially abrogated genomic cleavage by SpCas9, whereas spacers with mutations at farther upstream positions retained activity against the original protospacer target (FIG. 4B). In addition to the PAM, SpCas9 has single-base specificity within the last 12-bp of the spacer. Furthermore, CRISPR is able to mediate genomic cleavage as efficiently as a pair of TALE nucleases (TALEN) targeting the same EMX1 protospacer. FIG. 4C provides a schematic showing the design of TALENs targeting EMX1, and FIG. 4D shows a Surveyor gel comparing the efficiency of TALEN and Cas9 (n=3).

[0220] Having established a set of components for achieving CRISPR-mediated gene editing in mammalian cells through the error-prone NHEJ mechanism, the ability of CRISPR to stimulate homologous recombination (HR), a high fidelity gene repair pathway for making precise edits in the genome, was tested. The wild type SpCas9 is able to mediate site-specific DSBs, which can be repaired through both NHEJ and HR. In addition, an aspartate-to-alanine substitution (D10A) in the RuvC I catalytic domain of SpCas9 was engineered to convert the nuclease into a nickase (SpCas9n; illustrated in FIG. 5A) (see e.g. Sapanauskas et al., 2011, *Nucleic Acids Research*, 39: 9275; Gasiunas et al., 2012, *Proc. Natl. Acad. Sci. USA*, 109: E2579), such that nicked genomic DNA undergoes the

high-fidelity homology-directed repair (HDR). Surveyor assay confirmed that SpCas9n does not generate indels at the EMX1 protospacer target. As illustrated in FIG. 5B, co-expression of EMX1-targeting chimeric crRNA with SpCas9 produced indels in the target site, whereas co-expression with SpCas9n did not (n=3). Moreover, sequencing of 327 amplicons did not detect any indels induced by SpCas9n. The same locus was selected to test CRISPR-mediated HR by co-transfecting HEK 293FT cells with the chimeric RNA targeting EMX1, hSpCas9 or hSpCas9n, as well as a HR template to introduce a pair of restriction sites (HindIII and NheI) near the protospacer. FIG. 5C provides a schematic illustration of the HR strategy, with relative locations of recombination points and primer annealing sequences (arrows). SpCas9 and SpCas9n indeed catalyzed integration of the HR template into the EMX1 locus. PCR amplification of the target region followed by restriction digest with HindIII revealed cleavage products corresponding to expected fragment sizes (arrows in restriction fragment length polymorphism gel analysis shown in FIG. 5D), with SpCas9 and SpCas9n mediating similar levels of HR efficiencies. Applicants further verified HR using Sanger sequencing of genomic amplicons (FIG. 5E). These results demonstrate the utility of CRISPR for facilitating targeted gene insertion in the mammalian genome. Given the 14-bp (12-bp from the spacer and 2-bp from the PAM) target specificity of the wild type SpCas9, the availability of a nickase can significantly reduce the likelihood of off-target modifications, since single strand breaks are not substrates for the error-prone NHEJ pathway.

[0221] Expression constructs mimicking the natural architecture of CRISPR loci with arrayed spacers (FIG. 2A) were constructed to test the possibility of multiplexed sequence targeting. Using a single CRISPR array encoding a pair of EMX1- and PVALB-targeting spacers, efficient cleavage at both loci was detected (FIG. 4F, showing both a schematic design of the crRNA array and a Surveyor blot showing efficient mediation of cleavage). Targeted deletion of larger genomic regions through concurrent DSBs using spacers against two targets within EMX1 spaced by 119 bp was also tested, and a 1.6% deletion efficacy (3 out of 182 amplicons; FIG. 4G) was detected. This demonstrates that the CRISPR system can mediate multiplexed editing within a single genome.

Example 2: CRISPR System Modifications and Alternatives

[0222] The ability to use RNA to program sequence-specific DNA cleavage defines a new class of genome engineering tools for a variety of research and industrial applications. Several aspects of the CRISPR system can be further improved to increase the efficiency and versatility of CRISPR targeting. Optimal Cas9 activity may depend on the availability of free Mg²⁺ at levels higher than that present in the mammalian nucleus (see e.g. Jinek et al., 2012, Science, 337:816), and the preference for an NGG motif immediately downstream of the protospacer restricts the ability to target on average every 12-bp in the human genome (FIG. 11, evaluating both plus and minus strands of human chromosomal sequences). Some of these constraints can be overcome by exploring the diversity of CRISPR loci across the microbial metagenome (see e.g. Makarova et al., 2011, Nat Rev Microbiol, 9:467). Other CRISPR loci may be transplanted into the mammalian cellular milieu by a process

similar to that described in Example 1. For example, FIG. 12 illustrates adaptation of the Type II CRISPR system from CRISPR 1 of *Streptococcus thermophilus* LMD-9 for heterologous expression in mammalian cells to achieve CRISPR-mediated genome editing. FIG. 12A provides a Schematic illustration of CRISPR 1 from *S. thermophilus* LMD-9. FIG. 12B illustrates the design of an expression system for the *S. thermophilus* CRISPR system. Human codon-optimized hStCas9 is expressed using a constitutive EF1 α promoter. Mature versions of tracrRNA and crRNA are expressed using the U6 promoter to promote precise transcription initiation. Sequences from the mature crRNA and tracrRNA are illustrated. A single base indicated by the lower case "a" in the crRNA sequence is used to remove the polyU sequence, which serves as a RNA polIII transcriptional terminator. FIG. 12C provides a schematic showing guide sequences targeting the human EMX1 locus as well as their predicted secondary structures. The modification efficiency at each target site is indicated below the RNA secondary structures. The algorithm generating the structures colors each base according to its probability of assuming the predicted secondary structure, which is indicated by a rainbow scale reproduced in FIG. 12C in gray scale. FIG. 12D shows the results of hStCas9-mediated cleavage in the target locus using the Surveyor assay. RNA guide spacers 1 and 2 induced 14% and 6.4%, respectively. Statistical analysis of cleavage activity across biological replica at these two protospacer sites is also provided in FIG. 6. FIG. 16 provides a schematic of additional protospacer and corresponding PAM sequence targets of the *S. thermophilus* CRISPR system in the human EMX1 locus. Two protospacer sequences are highlighted and their corresponding PAM sequences satisfying NNAGAAW motif are indicated by underlining 3' with respect to the corresponding highlighted sequence. Both protospacers target the anti-sense strand.

Example 3: Sample Target Sequence Selection Algorithm

[0223] A software program is designed to identify candidate CRISPR target sequences on both strands of an input DNA sequence based on desired guide sequence length and a CRISPR motif sequence (PAM) for a specified CRISPR enzyme. For example, target sites for Cas9 from *S. pyogenes*, with PAM sequences NGG, may be identified by searching for 5'-N_x-NGG-3' both on the input sequence and on the reverse-complement of the input. Likewise, target sites for Cas9 of *S. thermophilus* CRISPR1, with PAM sequence NNAGAAW, may be identified by searching for 5'-N_x-NNAGAAW-3' (SEQ ID NO: 29) both on the input sequence and on the reverse-complement of the input. Likewise, target sites for Cas9 of *S. thermophilus* CRISPR3, with PAM sequence NGGNG, may be identified by searching for 5'-N_x-NGGNG-3' both on the input sequence and on the reverse-complement of the input. The value "x" in N_x may be fixed by the program or specified by the user, such as 20.

[0224] Since multiple occurrences in the genome of the DNA target site may lead to nonspecific genome editing, after identifying all potential sites, the program filters out sequences based on the number of times they appear in the relevant reference genome. For those CRISPR enzymes for which sequence specificity is determined by a 'seed' sequence, such as the 11-12 bp 5' from the PAM sequence, including the PAM sequence itself, the filtering step may be

based on the seed sequence. Thus, to avoid editing at additional genomic loci, results are filtered based on the number of occurrences of the seed:PAM sequence in the relevant genome. The user may be allowed to choose the length of the seed sequence. The user may also be allowed to specify the number of occurrences of the seed:PAM sequence in a genome for purposes of passing the filter. The default is to screen for unique sequences. Filtration level is altered by changing both the length of the seed sequence and the number of occurrences of the sequence in the genome. The program may in addition or alternatively provide the sequence of a guide sequence complementary to the reported target sequence(s) by providing the reverse complement of the identified target sequence(s).

[0225] Further details of methods and algorithms to optimize sequence selection can be found in U.S. application Ser. No. 61/836,080 (attorney docket 44790.11.2022); incorporated herein by reference.

Example 4: Evaluation of Multiple Chimeric crRNA-tracrRNA Hybrids

[0226] This example describes results obtained for chimeric RNAs (chiRNAs; comprising a guide sequence, a tracr mate sequence, and a tracr sequence in a single transcript) having tracr sequences that incorporate different lengths of wild-type tracrRNA sequence. FIG. 18a illustrates a schematic of a bicistronic expression vector for chimeric RNA and Cas9. Cas9 is driven by the CBh promoter and the chimeric RNA is driven by a U6 promoter. The chimeric guide RNA consists of a 20 bp guide sequence (Ns) joined to the tracr sequence (running from the first “U” of the lower strand to the end of the transcript), which is truncated at various positions as indicated. The guide and tracr sequences are separated by the tracr-mate sequence GUUUUA-GAGCUA (SEQ ID NO: 30) followed by the loop sequence GAAA. Results of SURVEYOR assays for Cas9-mediated indels at the human EMX1 and PVALB loci are illustrated in FIGS. 18b and 18c, respectively. Arrows indicate the expected SURVEYOR fragments. ChiRNAs are indicated by their “+n” designation, and crRNA refers to a hybrid RNA where guide and tracr sequences are expressed as separate transcripts. Quantification of these results, performed in triplicate, are illustrated by histogram in FIGS. 19a and 19b, corresponding to FIGS. 18b and 18c, respectively (“N.D.” indicates no indels detected). Protospacer IDs and their corresponding genomic target, protospacer sequence, PAM sequence, and strand location are provided in Table D. Guide sequences were designed to be complementary to the entire protospacer sequence in the case of separate transcripts in the hybrid system, or only to the underlined portion in the case of chimeric RNAs.

TABLE D

protospacer ID	genomic target	protospacer sequence (5' to 3')	PAM	strand
1	EMX1	<u>GGACATCGATGTCACCTCCA</u> <u>ATGACTAGGG</u> (SEQ ID NO: 31)	TGG	+
2	EMX1	<u>CATTGGAGGTGACATCGATG</u> <u>TCCTCCCAT</u> (SEQ ID NO: 32)	TGG	-

TABLE D-continued

protospacer ID	genomic target	protospacer sequence (5' to 3')	PAM	strand
3	EMX1	<u>GGAAGGGCCTGAGTCCGAGCA</u> <u>GAGAAGAA</u> (SEQ ID NO: 33)	GGG	+
4	PVALB	<u>GGTGGCGAGAGGGGCCGAGA</u> <u>TTGGGTGTTC</u> (SEQ ID NO: 34)	AGG	+
5	PVALB	<u>ATGCAGGAGGGTGGCGAGAG</u> <u>GGGCCGAGAT</u> (SEQ ID NO: 35)	TGG	+

[0227] Cell Culture and Transfection

[0228] Human embryonic kidney (HEK) cell line 293FT (Life Technologies) was maintained in Dulbecco's modified Eagle's Medium (DMEM) supplemented with 10% fetal bovine serum (HyClone), 2 mM GlutaMAX (Life Technologies), 100 U/mL penicillin, and 100 g/mL streptomycin at 37° C. with 5% CO₂ incubation. 293FT cells were seeded onto 24-well plates (Corning) 24 hours prior to transfection at a density of 150,000 cells per well. Cells were transfected using Lipofectamine 2000 (Life Technologies) following the manufacturer's recommended protocol. For each well of a 24-well plate, a total of 500 ng plasmid was used.

[0229] SURVEYOR Assay for Genome Modification

[0230] FT cells were transfected with plasmid DNA as described above. Cells were incubated at 37° C. for 72 hours post-transfection prior to genomic DNA extraction. Genomic DNA was extracted using the QuickExtract DNA Extraction Solution (Epicentre) following the manufacturer's protocol. Briefly, pelleted cells were resuspended in QuickExtract solution and incubated at 65° C. for 15 minutes and 98° C. for 10 minutes. The genomic region flanking the CRISPR target site for each gene was PCR amplified (primers listed in Table E), and products were purified using QiaQuick Spin Column (Qiagen) following the manufacturer's protocol. 400 ng total of the purified PCR products were mixed with 2 µl 10× Taq DNA Polymerase PCR buffer (Enzymatics) and ultrapure water to a final volume of 201, and subjected to a re-annealing process to enable heteroduplex formation: 95° C. for 10 min, 95° C. to 85° C. ramping at -2° C./s, 85° C. to 25° C. at -0.25° C./s, and 25° C. hold for 1 minute. After re-annealing, products were treated with SURVEYOR nuclease and SURVEYOR enhancer S (Transgenomics) following the manufacturer's recommended protocol, and analyzed on 4-20% Novex TBE poly-acrylamide gels (Life Technologies). Gels were stained with SYBR Gold DNA stain (Life Technologies) for 30 minutes and imaged with a Gel Doc gel imaging system (Bio-rad). Quantification was based on relative band intensities.

TABLE E

primer name	genomic target	primer sequence (5' to 3')
Sp-EMX1-F	EMX1	<u>AAAACCACCCTTCTCTGGC</u> (SEQ ID NO: 36)
Sp-EMX1-R	EMX1	<u>GGAGATTGGAGACACGGAGA</u> G (SEQ ID NO: 37)

TABLE E-continued

primer name	genomic target	primer sequence (5' to 3')
Sp-PVALB-F	PVALB	CTGGAAGCCAATGCCTGAC (SEQ ID NO: 38)
Sp-PVALB-R	PVALB	GGCAGCAAACCTCTGTCTCT (SEQ ID NO: 39)

[0231] Computational Identification of Unique CRISPR Target Sites

[0232] To identify unique target sites for the *S. pyogenes* SF370 Cas9 (SpCas9) enzyme in the human, mouse, rat, zebrafish, fruit fly, and *C. elegans* genome, we developed a software package to scan both strands of a DNA sequence and identify all possible SpCas9 target sites. For this example, each SpCas9 target site was operationally defined as a 20 bp sequence followed by an NGG protospacer adjacent motif (PAM) sequence, and we identified all sequences satisfying this 5'-N20-NGG-3' definition on all chromosomes. To prevent non-specific genome editing, after identifying all potential sites, all target sites were filtered based on the number of times they appear in the relevant reference genome. To take advantage of sequence specificity of Cas9 activity conferred by a 'seed' sequence, which can be, for example, approximately 11-12 bp sequence 5' from the PAM sequence, 5'-NNNNNNNNNN-NGG-3' sequences were selected to be unique in the relevant genome. All genomic sequences were downloaded from the UCSC Genome Browser (Human genome hg19, Mouse genome mm9, Rat genome rn5, Zebrafish genome danRer7, *D. melanogaster* genome dm4 and *C. elegans* genome ce10). The full search results are available to browse using UCSC Genome Browser information. An example visualization of some target sites in the human genome is provided in FIG. 21.

[0233] Initially, three sites within the EMX1 locus in human HEK 293FT cells were targeted. Genome modification efficiency of each chiRNA was assessed using the SURVEYOR nuclease assay, which detects mutations resulting from DNA double-strand breaks (DSBs) and their subsequent repair by the non-homologous end joining (NHEJ) DNA damage repair pathway. Constructs designated chiRNA(+n) indicate that up to the +n nucleotide of wild-type tracrRNA is included in the chimeric RNA construct, with values of 48, 54, 67, and 85 used for n. Chimeric RNAs containing longer fragments of wild-type tracrRNA (chiRNA(+67) and chiRNA(+85)) mediated DNA cleavage at all three EMX1 target sites, with chiRNA(+85) in par-

ticular demonstrating significantly higher levels of DNA cleavage than the corresponding crRNA/tracrRNA hybrids that expressed guide and tracr sequences in separate transcripts (FIGS. 18b and 19a). Two sites in the PVALB locus that yielded no detectable cleavage using the hybrid system (guide sequence and tracr sequence expressed as separate transcripts) were also targeted using chiRNAs. chiRNA(+67) and chiRNA(+85) were able to mediate significant cleavage at the two PVALB protospacers (FIGS. 18c and 19b).

[0234] For all five targets in the EMX1 and PVALB loci, a consistent increase in genome modification efficiency with increasing tracr sequence length was observed. Without wishing to be bound by any theory, the secondary structure formed by the 3' end of the tracrRNA may play a role in enhancing the rate of CRISPR complex formation. An illustration of predicted secondary structures for each of the chimeric RNAs used in this example is provided in FIG. 21. The secondary structure was predicted using RNAfold using minimum free energy and partition function algorithm. Pseudocolor for each based (reproduced in grayscale) indicates the probability of pairing. Because chiRNAs with longer tracr sequences were able to cleave targets that were not cleaved by native CRISPR crRNA/tracrRNA hybrids, it is possible that chimeric RNA may be loaded onto Cas9 more efficiently than its native hybrid counterpart. To facilitate the application of Cas9 for site-specific genome editing in eukaryotic cells and organisms, all predicted unique target sites for the *S. pyogenes* Cas9 were computationally identified in the human, mouse, rat, zebra fish, *C. elegans*, and *D. melanogaster* genomes. Chimeric RNAs can be designed for Cas9 enzymes from other microbes to expand the target space of CRISPR RNA-programmable nucleases.

[0235] FIG. 22 illustrates an exemplary bicistronic expression vector for expression of chimeric RNA including up to the +85 nucleotide of wild-type tracr RNA sequence, and SpCas9 with nuclear localization sequences. SpCas9 is expressed from a CBh promoter and terminated with the bGH polyA signal (bGH pA). The expanded sequence illustrated immediately below the schematic corresponds to the region surrounding the guide sequence insertion site, and includes, from 5' to 3', 3'-portion of the U6 promoter (first shaded region), BbsI cleavage sites (arrows), partial direct repeat (tracr mate sequence GTTTTAGAGCTA (SEQ ID NO: 27), underlined), loop sequence GAAA, and +85 tracr sequence (underlined sequence following loop sequence). An exemplary guide sequence insert is illustrated below the guide sequence insertion site, with nucleotides of the guide sequence for a selected target represented by an "N".

[0236] Sequences described in the above examples are as follows (polynucleotide sequences are 5' to 3'):

U6-short tracrRNA (*Streptococcus pyogenes* SF370):
(SEQ ID NO: 40)
GAGGGCCTATTTCCCATGATTCCTTCATATTTGCATATACGATACAAGGCT

GTTAGAGAGATAATTGGAATTAATTTGACTGTAACACAAAGATATTAGTACAAAA

TACGTGACGTAGAAAGTAATAATTTCTGGGTAGTTTGCAGTTTTAAAATTATGTTTT

AAAATGGACTATCATATGCTTACCGTAACTTGAAAGTATTTTCGATTTCTGGCTTTAT

-continued

ATATCTTGTGAAAGGACGAAACACCGGAACCATTCAAAACAGCATAGCAAGTTA

AAATAAGGCTAGTCCGTTATCAACTTGAAAAAGTGGCACCGAGTCGGTGCTTTT

TTT (bold = tracrRNA sequence; underline = terminator sequence)

U6-long tracrRNA (*Streptococcus pyogenes* SF370) :

(SEQ ID NO: 41)

GAGGGCCTATTTCCCATGATTCCTTCATATTTGCATATACGATACAAGGCT

GTTAGAGAGATAAATGGAATTAATTTGACTGTAAACACAAGATATTAGTACAAAA

TACGTGACGTAGAAAAGTAATAATTTCTTGGGTAGTTGCAGTTTTAAAATTATGTTTT

AAAATGGACTATCATATGCTTACCGTAACTTGAAAGTATTTTCGATTTCTTGGCTTTAT

ATATCTTGTGAAAGGACGAAACACCGGTAGTATTAAGTATTGTTTTATGGCTGATA

AATTTCTTTGAATTTCTCCTTGATTATTGTTATAAAAAGTTATAAAAATAATCTTGTG

GAACCATTCAAACAGCATAGCAAGTTAAAATAAGGCTAGTCCGTTATCAACTTGA

AAAAGTGGCACCGAGTCGGTGC

U6-DR-BbsI backbone-DR (*Streptococcus pyogenes* SF370) :

(SEQ ID NO: 42)

GAGGGCCTATTTCCCATGATTCCTTCATATTTGCATATACGATACAAGGCT

GTTAGAGAGATAAATGGAATTAATTTGACTGTAAACACAAGATATTAGTACAAAA

TACGTGACGTAGAAAAGTAATAATTTCTTGGGTAGTTGCAGTTTTAAAATTATGTTTT

AAAATGGACTATCATATGCTTACCGTAACTTGAAAGTATTTTCGATTTCTTGGCTTTAT

ATATCTTGTGAAAGGACGAAACACCGGTTTTAGAGCTATGCTGTTTTGAATGGTC

CCAAAACGGTCTTCGAGAAGACGTTTTAGAGCTATGCTGTTTTGAATGGTCCCAA

AC

U6-chimeric RNA-BbsI backbone (*Streptococcus pyogenes* SF370)

(SEQ ID NO: 43)

GAGGGCCTATTTCCCATGATTCCTTCATATTTGCATATACGATACAAGGCT

GTTAGAGAGATAAATGGAATTAATTTGACTGTAAACACAAGATATTAGTACAAAA

TACGTGACGTAGAAAAGTAATAATTTCTTGGGTAGTTGCAGTTTTAAAATTATGTTTT

AAAATGGACTATCATATGCTTACCGTAACTTGAAAGTATTTTCGATTTCTTGGCTTTAT

ATATCTTGTGAAAGGACGAAACACCGGTCTTCGAGAAGACCTGTTTTAGAGCTA

GAAATAGCAAGTTAAAATAAGGCTAGTCCG

NLS-SpCas9-EGFP:

(SEQ ID NO: 44)

MDYKDHDGDYKDHDIDYKDDDDKMAPKKRKGVIHGVPAAADKKYSIGLDI

GTNSVGWAVITDEYKVPSSKKFKVLGNTDRHSIKKNLIGALLFDSGETAEATRLKRTARR

RYTRKRNRIICYLQEIFSNEMAKVDDSPFHRLEESFLVEEDKKHERHPIFGNIVDEVAYHE

KYPTIYHLRKKLVSDTKADLRLIYLALAHMIKFRGHFLIEGDLNPDNSVDKLFIQLVQ

TYNQLFEENPINASGVDAKAILSARLSKSRLENLIAQLPGEKKNGLFGNLIALSLGLTPN

FKSNFDLAEDAKLQLSKDITYDDDLNLLAQIGDQYADLFLAAKNLSDAILLSDILRVNT

EITKAPLSASMIKRYDEHHQDLTLKALVRRQQLPEKYKEIFFDQSKNGYAGYIDGGASQ

EEFYKFIKPILEKMDGTEELLVKLNREDLLRKQRTFDNGSIPHQIHLGELHAILRRQEDFY

PFLKDNREKIEKILTFRIPYVGPLARGNSRFAMTRKSEETITPWNFEVVDKGSASQS

FIERMTNFDKNLPNEKVLPHKSLLYEYFTVYNELTKVKYVTEGMRKPAFLSGEQKKAIV

DLLFKTRNRKVTVKQLKEDYFKKIECFDSVEISGVEDRPNASLGTYHDLKIKDKDFLDN

-continued

EENEDI LEDIVLTLTLFEDREMI EERLKYAHLFDDKVMKQLKRRRYTGWGRLSRKLIN
GIRDKQSGKTI LDPLKSDGFANRNFMLIHDDSLTFKEDIQKAQVSGQGDSLHEHIANLA
GSPAIIKKGILQTVKVVDELVKVMGRHKPENIVIEMARENQTTQKGQNSRERMKRIEEG
IKELGSQILKEHPVENTQLQNEKLYLYLQNGRDMYVDQELDINRLSDYDVDHIVPQSF
LKDDSIDNKVLTRSDKNRGKSDNVPSEEVVKKMKNYWRQLLNAKLITQRKFDNLTKAE
RGGLSELDKAGFIKRQLVETRQITKHVAQILDSRMNTKYDENDKLIREVKVITLKSCLVS
DFRKDFQFYKREINNYHHAHDAYLNAVGTALIKKYPKLESEFVYGDYKVDVRKMI
AKSEQEIGKATAKYFFYSNIMNFKTEITLANGEIRKRPLIETNGETGEIVWDKGRDFATV
RKVLSMPQVNIIVKKEVQTTGGFSKESILPKRNSDKLIARKKDWDPKKYGGFDSPTVAYS
VLVVAKEKGGKSKLKSVKELLGITIMERSSEKPNIDFLEAKGYKEVKKDLIIKLPKYS
LFELENGRKRMLASAGELQKGNELALPSKYVNFLYLASHYEKLGKSPEDNEQKQLFVE
QHKHYLDEIIIEQISEFSKRVI LADANLDKVL SAYNKHDKPIREQAENI IHLFTLTNLGAP
AAFKYFDTTIDRKRYSSTKEVL DATLIHQSI TGLYETRIDLSQLGGDAAAVSKGEELFTG
VVPILVELDGDVNGHKFSVSGEGEDATYGLTLKFICTTGKLPVPWPTLVTTLYGVQ
CFSRYPDHMKQHDFPKSAMPEGYVQERTIFFKDDGNYKTRAEVKFEGDTLVNRIELKGI
DFKEDGNI LGHKLEYNYNSHNVIYIMADKQKNGIKVNFKIRHNI EDGSVQLADHYQONT
PIGDGPVLLPDNHYLSTQSALS KDPNEKRDHMLLEFVTAAGITLGMDELYK
SpCas9 - EGFP - NLS : (SEQ ID NO: 45)
MDKKYSIGLDIGTNSVGVAVI TDEYKVPSSKKFKVLGNTDRHSIKKNLIGALLF
DSGETAEATRLKRTARRRYTRRKNRICYLQEIFSNEMAKVDDSPFHRLEESFLVEEDKK
HERHPIFGNIVDEVAYHEKYPTIYHLRKKLVSDTKADLRLLIYALAHMIKFRGHFLIEG
DLNPDNSDVKLFIQLVQTYNQLFEENPINASGVDAKAIL SARLSKSRRENLI AQLPGE
KKNGLFGNLI ALSGLTPNFKSNFDLAEDAKLQLSKDTYDDDLNLLAQIGDQYADLFL
AAKNLSDAILLSDILRVNTEITKAPLSASMIKRYDEHHQDLTLKALVRQQLPKYKEIFF
DQSKNGYAGYIDGGASQEEFYKFIKPILEKMDGTEELLVKLNREDLLRQRFTDNGSIPH
QIHLGELHAILRRQEDFYFPLKDNREKIEKILTFRIPYVGPLARGNSRFAMWTRKSEETI
TPWNFEVVDKGASAQSFIERMTNFDKNLPNEKVLPKHSLLEYFTVYNELTKVKYVTE
GMRKPAFLSGEQKKAIVDLDFKTRKVTVKQLKEDYFKKIECFDSVEISGVEDRFNASL
GTYHDLKIIKDKDFLDNEENEDI LEDIVLTLTLFEDREMI EERLKYAHLFDDKVMKQL
KRRRYTGWGRLSRKLINGIRDKQSGKTI LDPLKSDGFANRNFMLIHDDSLTFKEDIQKA
QVSGQGDSLHEHIANLAGSPAIIKKGILQTVKVVDELVKVMGRHKPENIVIEMARENQTT
QKGQNSRERMKRIEEGIKELGSQILKEHPVENTQLQNEKLYLYLQNGRDMYVDQEL
DINRLSDYDVDHIVPQSFLKDDSIDNKVLTRSDKNRGKSDNVPSEEVVKKMKNYWRQL
LNAKLITQRKFDNLTKAERGGLELDKAGFIKRQLVETRQITKHVAQILDSRMNTKYDE
NDKLIREVKVITLKSCLVSDFRKDFQFYKREINNYHHAHDAYLNAVGTALIKKYPKL
ESEFVYGDYKVDVRKMI AKSEQEIGKATAKYFFYSNIMNFKTEITLANGEIRKRPLIET
NGETGEIVWDKGRDFATVRKVLSMPQVNIIVKKEVQTTGGFSKESILPKRNSDKLIARKK
DWDPKKYGGFDSPTVAYSVLVVAKEKGGKSKLKSVKELLGITIMERSSEKPNIDFLE
AKGYKEVKKDLIIKLPKYSLFELENGRKRMLASAGELQKGNELALPSKYVNFLYLASHY

-continued

EKLKGS PEDNEQKQLFVEQHKHYLDEI IEQISEFSKRVI LADANL DKVLSAYNKHRDKPI
 REQAENI IHLFTLTNLGAPAAFKYFDTTIDRKRYTSTKEVLDATLIHQSI TGLYETRIDL SQ
 LGGDAAAVSKGEEELFTGVVPI LVELDGDVNGHKFSVSGEGEGDATYGKLT LKFICTTGK
 LPVPWPTLVTTLTLYGVQCF SRYPDHMKQHDFFKSAMPEGYVQERTIFFKDDGNYKTRA
 EVKPEGDTLVNRIELKGI DFKEDGNI LGHKLEYNYNSHNVYIMADKQKNGI KVNFKIRH
 NIEDGSVQLADHYQONTPIGDGPVLLPDNHYLSTQSALS KDPNEKRDHMLLEFVTAAG
 ITLGMDELYKKRPAATKKAGQAKKKK

NLS - SpCas9 - EGFP - NLS :

(SEQ ID NO: 46)

MDYKDHDGDYKDHD IDYKDDDDKMAPKKRKRKVG IHGVPAAADKKYS IGLDI
 GTNSVGWAVI TDEYKVP SKKPKVLGNTDRHSI KKNLIGALLFDSGETAEATRLKRTARR
 RYTRRKNRICYLQEIFSNEMAKVDDSFPHRLEESFLVEEDKKHERHP IFGNIVDEVAYHE
 KYPTIYHLRKKLV DSTKADLRLIYLALAHMI KPRGFHLI EGDLPDNDSDVKLFIQLVQ
 TYNQLFEEENPINASGVDAKAI LSARLSKSRLENLIAQLPGEKKNGLFGNLI ALSGLTPN
 FKS NFDLAEDAQLQ LSKD TYDDLDNL LAQIGDQYADLFLAAKNLSDAILLSDI LRVT
 EITKAPLSASMI KR YDEHHQDLTLLKALVRQQLPEKYKEI FFDQSKNGYAGYIDGGASQ
 EEFYKFIKPILEKMGTEELLV KLNREDLLRKQRTFDNGSIPHQIHLGELHAILRRQEDFY
 PFLKDNREKIEKILTFRIPYVGPLARGNSRFAMTRKSEETITPWNFEVVDK GASAQS
 FIERMTNFDKNLPNEKVL PKHSLLYEYFTVYNELTKVKYVTEGMRKPAFLS GEQKKAIV
 DLLFKTNRKVTVKQLKEDYFKKIECFDSVEISGVEDRFNASLGT YHDL LKI IKDKDFLDN
 EENEDI LEDIVLTLTLFEDREMI EERLKYAHLFDDKVMKQLKRRRYTGWGRLSRKLIN
 GIRDKQSGKTI LDFLKSDGFANRNFMLIHDDSLTFKEDIQKAQVSGQDLSHEHIANLA
 GSPA I KKGILQTVKVVDELVKVMGRHKPENIV IEMARENQTQKGQKNSRERMKRI EEG
 IKELGSQILKEHPVENTQLQNEKLYLYLQNGRDMYVDQELDINRLSDYDVDHIVPQSF
 LKDDSIDNKVLTRSDKNRGKSDNVPSEEVVKKMKNYWRQLLNAKLITQRKFDNLTKAE
 RGGSELDKAGFIKRQLVETRQITKHVAQILDSRMNTKYDENDKLIREVKVITLKS KLVS
 DFRKDFQFYKREINNYHHAHDAYLNAVVG TALI KKYPKLESEFVYGDYKVDVRKMI
 AKSEQEIGKATAKYFFYSNIMNFFKTEITLANGEIRKRPLIETNGETGEIVWDKGRDFATV
 RKVLSMPQVNI VKKTEVQTGGFSKESILPKRNSDKLIARKKDWDPKKYGGFDSPTVAYS
 VLVVAKVEKGKSKLKS VKELLGITIMERS SFEKNPIDFLEAKGYKEVKKDLI IKLPKYS
 LFELENGRKRMLASAGELQKGNELALPSKYVNFLYLASHYEKLGKSPEDNEQKQLFVE
 QHKHYLDEI IEQISEFSKRVI LADANL DKVLSAYNKHRDKPI REQAENI IHLFTLTNLGAP
 AAFKYFDTTIDRKRYTSTKEVLDATLIHQSI TGLYETRIDL SQ LGGDAAAVSKGEEELFTG
 VVPI LVELDGDVNGHKFSVSGEGEGDATYGKLT LKFICTTGKLPVPWPTLVTTLTLYGVQ
 CFSRYPDHMKQHDFFKSAMPEGYVQERTIFFKDDGNYKTRA EVKPEGDTLVNRIELKGI
 DFKEDGNI LGHKLEYNYNSHNVYIMADKQKNGI KVNFKIRH NIEDGSVQLADHYQONT
 PIGDGPVLLPDNHYLSTQSALS KDPNEKRDHMLLEFVTAAGITLGMDELYKKRPAATK
 KAGQAKKKK

-continued

NLS-SpCas9-NLS :

(SEQ ID NO: 47)

MDYKDHDGDYKDHDIDYKDDDDKMAPKKRKGIVHGVPAAADKKYSIGLDI
 GTNSVGVAVITDEYKVPSSKFKVLGNTDRHSIKKNLIGALLFDSGETABEATRLKRTARR
 RYTRRKNRICYLQEIFSNEMAKVDDSFHRLEESFLVEEDKHERHPIFGNIVDEVAYHE
 KYPTIYHLRKKLVSTDKADLRLIYLALAHMIKFRGHFLIEGDLNPDNSVDKLFIQLVQ
 TYNQLFEENPINASGVDAKAILSARLSKSRLENLIAQLPGEKKNLPGNLIALSLGLTPN
 FKSDFLAEDAKLQLSKDTYDDDLNLLAQIGDQYADLFLAAKNLSDAILLSDILRVNT
 EITKAPLSASMIKRYDEHHQDLTLLKALVRRQQLPEKYKEIFFDQSKNGYAGYIDGGASQ
 EEFYKFIKPILEKMDGTEELLVKNREDLLRQRTFDNGSIPHQIHLGELHAILRRQEDFY
 PFLKDNREKIEKILTFRIPYVGLARGNSRFAWMTKSEETITPWNFEEVVDKGSASQ
 FIERMTNFDKNLPNEKVLPHKSLLYEYFTVYNELTKVKYVTEGMRKPAFLSAGEQKKAIV
 DLLFKNTRKVTVKQLKEDYFKKIECFDSVEISGVEDRPNASLGTYHDLKI IKDKDFLDN
 EENEDILEDIVLTLTLFEDREMI EERLKYAHLFDDKVMKQLKRRRYTGWGRLSRKLIN
 GIRDKQSGKTI LDFLKSDFANRNFQLIHDDSLTFKEDIQKAQVSGQGS LHEHIANLA
 GSPAIIKKGILQTVKVVDELVKVMGRHKPENIVIMARENQTTQKGQNSRERMKRIEEG
 IKELGSQILKEHPVENTQLQNEKLYLYLQNGRDMYVDQELDINRLSDYDVIDHIVQSF
 LKDDSIDNKVLTRSDKNRGKSDNVPSEEVVKKMKNYWRQLLNAKLITQRKFDNLTKAE
 RGGLSELDKAGFIKRQLVETRQITKHVAQILDSRMNTKYDENDKLIREVKVITLKS KLVS
 DPRKDFQFYKREINNYHHAHDAYLNAVGTALIKKYPKLESEFVYGDYKVYDVRKMI
 AKSEQEIGKATAKYFFYSNIMNFFKTEITLANGEIRKRPLIETNGETGEIVWDKGRDFATV
 RKVLSMPQVNIIVKKTVEVQTGGFSKESILPKRNSDKLIARKKDWDPKKYGGFDSPTVAYS
 VLVVAKVEKGGKSKLKSVELLGITIMERSSEKPNIDFLEAKGYKEVKKDLIIKLPKYS
 LPELENGRKRMLASAGELQKGNELALPSKYVNFYLYASHYEKLGKSPEDNEQKQLFVE
 QHKHYLDEIIIEQISEFSKRVI LADANLDKVL SAYNKHRDKPIREQAENI IHLFTLTNLGAP
 AAFKYFDTTIDRKRYTSTKEVLDATLIHQSI TGLYETRIDLSQLGGDKRPAATKKAGQAK
 KKK

NLS-mCherry-SpRNase3 :

(SEQ ID NO: 48)

MFLFLSLTSFLSSRTLVS KGEEDNMAIIEFMRFKVHMEGSVNGHEFEIEGE
 GEGRPYEGTQTAKLKVTKGGPLPFAWDILSPQFMYGSKAYVKHPADIPDYLKLSFPEGF
 KWERMNPFEDGGVVTVTQDSSLQDGEFIYKVKLRGTNFPSPDGPVMQKKTMGWEASSE
 RMYPEDGALKGEIKQRLKLDGGHYDAEVKTTYKAKKPVQLPGAYNVNI KLDITSHNE
 DYTIVEQYERAERHSTGGMDELYKGSKQLELLSTSFDIQFNDLTLETAFTHTSYANE
 HRLLNVS HNERLEFLGDAVLQLIISEYLFAYPKKTEGMSKLRSMIVREESLAGFSRFC
 SFDAYIKLGKGEKSGGRRRTILGDLFEAPL GALLLDKIDAVRRFLKQVMI PQVEKG
 NPERVKDYKTCLOEFLQTKGDVAIDYQVISEKGAHAKQFEVSI VVNGAVLSKGLGKSK
 KLAEQDAKNAQLSEV

SpRNase3-mCherry-NLS :

(SEQ ID NO: 49)

MKQLELLSTSFDIQFNDLTLETAFTHTSYANEHRLLNVS HNERLEFLGDAV
 LQLIISEYLFAYPKKTEGMSKLRSMIVREESLAGFSRFCSDAYIKLGKGEKSGGRR

-continued

RDTILGDLFEAFLGALLLDKGI DAVRRFLKQVMI PQVEKGNFERVKDYKTCLQEFLQTK
 GDVAIDYQVISEKGPAAHAKQFEVSI VVNGAVLSKGLGKSKKLAEQDAAKNALAQLSEV
 GSVSKGEEDNMAII KEFMRFKVHMEGVSNGHEFEIEGEGEGRPYEGTQTAKLKVTKGGP
 LFFAWDILSPQFMYGSKAYVKHPADIPDYLLKLSFPEGFKWERVMNFEDGGVVTVTQDS
 SLQDGEFIYKVKLRGTNFPDGPVMQKKTMGWEASSERMPEDGALKGEIKQRLKLD
 GGHYDAEVKTTYKAKKPVQLPGAYNVNIKLDITSHNEDYITVEQYERAEGRHSTGGMD
 ELYKKRPAATKAGQAKKKK

NLS-SpCas9n-NLS (the D10A nickase mutation is lowercase):
 (SEQ ID NO: 50)
 MDYKDHGDYKDHIDYKDDDDKMAPKKRKGIVHGVPAAKKYSIGLaI
 GTNSVGWAVITDEYKVPSPKPKVLGNTDRHSI KKNLIGALLFDSGETAEATRLKRTARR
 RYTRKRNRI CYLQEIFSNEMAKVDDSPFHRLEESFLVEEDKKHERHPIFGNIVDEVAYHE
 KYPTIYHLRKKLVDSTDKADLRLIYLALAHMIKFRGHFLIEGDLNPDNSDVKLFIQLVQ
 TYNQLFEENPINASGVDAKAII SARLSKSRLENLIAQLPGEKKNLFGNLIALSLGLTPN
 FKS NFDLAEDAKLQLSKD TYDDLDNLLAQIGDQYADLFLAAKNLSDAI LLSDILRVNT
 EITKAPLSASMIKRDEHHQDLTLLKALVRQQLP EKYKEIFFDQSKNGYAGYIDGGASQ
 EEFYKFIKPILEKMGTEELLVKNREDLLRKQRTFDNGSIPHQIHLGELHAILRRQEDFY
 PFLKDNREKIEKILTFRIPYVYVGLARGNSRFAMWTRKSEETITPWNFEVVDKGASAQS
 FIERMNFDPKNLPNEKVLPHKSLLYEYFTVYNELTKVKYVTEGMRKPAFLS GEQKKAIV
 DLLFKTNRKVTVKQLKEDYFKKIECFDSVEISGVEDRFNASLGTYHDL LKI IKDKDFLDN
 EENEDI LEDIVLTLTLFEDREMI EERLKYAHLFDDKVMKQLKRRRYTGWGRLSRKLIN
 GIRDKQSGKTI LDFLKS DGFANRNFQMLIHDDSLTFKEDIQKAQVSGQDSLHEHIANLA
 GSPAIIKKGILQTVKVVDELVKVMGRHKPENIVIAMARENQTTQKGQKNSRERMKRI EEG
 IKELGSQILKEHPVENTQLQNEKLYLYLQNGRDMYVDQELDINRLSDYDVDHIVPQSF
 LKDDSIDNKVLT RSDKNRGS DNVPS EEVVKKMKNYWRQLLNAKLITQRKFDNLTKAE
 RGGLSELDKAGFIKRLVETRQITKHVAQI LDRMNTKYDENDKLIREVKVITLKS KLVS
 DFRKDFQFYKVIINNYHHAHDAYLNAVVG TALI KKYPKLESEFVYGDYKVYDVRKMI
 AKSEQEIGKATAKYFFYSNIMNFPKTEITLANGEIRKRPLIETNGETGEIVWDKGRDFATV
 RKVLSMPQVNI VVKTEVQTGGFSKESILPKRNSDKLIARKKDWDPKKYGGFDSPTVAYS
 VLVVAKVEKGKSKKLKSVKELLGITIMERS SFKNPIDFLEAKGYKEVKKDLIIKLPKYS
 LFELENGRKRMLASAGELQKGNELALPSKYVNFYLYLASHYEKLGSPEDNEQKQLFVE
 QHKHYLDEIIEQISEFSKRVI LADANLDKVL SAYNKHRDKPIREQAENI IHLFTLTNLGAP
 AAFKYFDTTIDRKRVTSTKEVL DATLIHQSI TGLYETRIDLSQLGGDKRPAATKAGQAK
 KKK

hEMX1-HR Template-HindII-NheI:
 (SEQ ID NO: 51)
 GAATGCTGCCCTCAGACCCGCTTCCCTCCCTGTCTGTCTGTCCAAGGAGA
 ATGAGGTCTCACTGGTGGATTTCGGACTACCCGTGAGGAGCTGGCACCTGAGGGACA
 AGGCCCCCACCTGCCAGCTCCAGCCTCTGATGAGGGGTGGGAGAGAGCTACATG
 AGGTTGCTAAGAAAGCCTCCCTGAAGGAGACCACACAGTGTGTGAGGTGGAGTC
 TCTAGCAGCGGTTCTGTGCCCCAGGATAGTCTGGCTGTCCAGGCACTGCTCTTG

-continued

ATATAAACACCACCTCCTAGTTATGAAACCATGCCCATCTGCCTCTCTGTATGGAA
AAGAGCATGGGGCTGGCCCGTGGGGTGGTGTCCACTTTAGGCCCTGTGGGAGATCA
TGGGAACCACCGCAGTGGGTATAGGCTCTCTCATTACTACTCACATCCACTCTGT
GAAGAAGCGATTATGATCTCTCCTCTAGAACTCGTAGAGTCCCATGTCTGCCGGT
TCCAGAGCCTGCACTCCTCCACCTTGGCTTGGCTTTGCTGGGGCTAGAGGAGCTAGG
ATGCACAGCAGCTCTGTGACCCTTTGTTTGTAGAGGAACAGGAAAACACCCTTCTCT
CTGGCCCACTGTCTCTCTCCTGCCTGCCATCCCCTCTGTGAATGTAGACCCAT
GGGAGCAGCTGGTCAGAGGGGACCCCGGCTGGGGCCCTAACCTATGTAGCCTC
AGTCTTCCCACAGCTCTCAGCTCAGCCTGAGTGTGAGGCCCCAGTGGCTGCTCT
GGGGGCTCCTGAGTTTCTCATCTGTGCCCCCTCCCTCCCTGGCCAGGTGAAGGTGT
GGTTCAGAACCGGAGGACAAAGTACAAACGGCAGAAGCTGGAGGAGGAAGGGCC
TGAGTCCGAGCAGAAGAAGAGGGCTCCCATCACATCAACCGGTGGCGCATGCCA
CGAAGCAGGCCAATGGGAGGACATCGATGTACCTCCAATGACaagcttgctagcGGTGG
GCAACCACAAACCCACGAGGGCAGAGTGTCTGCTTGTCTGGCCAGGCCCTGCGT
GGGCCCAAGCTGGACTCTGGCCACTCCCTGGCCAGGCTTTGGGGAGGCTGGAGTC
ATGGCCCCACAGGGCTTGAAGCCCGGGCCGCAATTGACAGAGGACAAAGCAATGG
GCTGGCTGAGGCCTGGGACCACTTGGCCTTCTCCTCGGAGAGCCTGCCTGCCTGGGC
GGGCCCGCCCGCCACCGCAGCCTCCAGCTGCTCTCCGTGTCTCCAATCTCCCTTTTG
TTTTGATGCATTTCTGTTTTAATTTATTTCCAGGCACCACTGTAGTTAGTGATCCCC
AGTGTCCCCCTTCCCTATGGGAATAATAAAAGTCTCTCTCTTAATGACACGGGCATC
CAGCTCCAGCCCCAGAGCCTGGGGTGGTAGATTCCGGCTCTGAGGGCCAGTGGGG
CTGGTAGAGCAACCGCTTCCAGGCCTGGGAGCCTGGGGTGGGGTACTGGTGGAGG
GGGTCAAGGGTAATTCATTAACCTCTCTTTTGTGGGGGACCTGGTCTCTACCTC
CAGCTCCACAGCAGGAGAAACAGGCTAGACATAGGGAAGGGCCATCCTGTATCTTG
AGGGAGGACAGGCCAGGTCTTTCTTAACGTATTGAGAGGTGGGAATCAGGCCAG
GTAGTTCAATGGGAGAGGAGAGTCTCCCTCTGCCTAGAGACTCTGGTGGCTTCT
CCAGTTGAGGAGAAACAGAGGAAAGGGAGGATTGGGGTCTGGGGGAGGGAACA
CCATTCACAAAGGCTGACGGTTCAGTCCGAAGTCGTGGGCCACCAGGATGCTCA
CCTGTCTTGGAGAACCCTGGGCAGGTTGAGACTGCAGAGACAGGGCTTAAGGCT
GAGCCTGCAACCAGTCCCAGTGACTCAGGGCCTCCTCAGCCCAAGAAAGAGCAAC
GTGCCAGGGCCCGCTGAGCTCTTGTGTTCACTG

NLS - St Csn1 - NLS :

(SEQ ID NO: 52)

MKRPAATKKAGQAKKKKSDLVLGLDIGIGSVGVGILNKVTGEIHKNSRIFPA
AQAENLVRRTNRQRRLARRKKHRRVRLNRLFEEGLITDFTKISINLNPYQLRVKGL
TDELSNEELFIALKNMVKHRGISYLLDDASDDGNSVGDYAQIVKENSQLETKTPGQIQ
ERYQTYGQLRQDFTEKDGKHLINVPFPTSAJRSEALRILQTTQEFNPQITDEFINRYL
EILTGKRKYHGPNEKSRDYGRTSGETLDNIFGILIGKCTFYPDEFRAAKASYTAQ
EFNLLNDLNLNLTVPTEKTKLSKEQKNQIINVVKNEKAMGPAKLFKYIAKLLSCDVADIK
GYRIDKSGKAEIHTFEAYRKMKTLETLDIEQMDRETLDKLAYVLTNLNTEREIQEALHE

-continued

FADGSFSQKQVDELVQFRKANSSIPGKGWHNFSVKLMMELIPELYETSEEQMTILTRLG
 KQKTTSSSNKTKYIDEKLLTEEIYNPVVAKSVRQAIKIVNAAIKEYGDFDNIVIEMARETN
 EDDEKKAIQKIQKANKDEKDAAMLKAANQYNGKAELPHSVFHGHKQLATKIRLWHQQ
 GERCLYTGKTI SIHDLINNSNQFEVDHILPLSITFDDSLANKVLVYATANQEKQRTPYQ
 ALDSMDDAWSFRELKAFVRESKTLNKKKEYLLTEEDI SKFDVRKKFIERNLVDTRYAS
 RVVLNALQEHFRAHKIDTKVSVVRGQFTSQLRRHWGIEKTRDTHHHAVDALIIAASSQ
 LNLWKKQKNTLVSYSEDQLLDIETGELISSDDEYKESVFKAPYQHFVDTLKSKEFEDSILF
 SYQVDSKPNRKISDATIYATRQAKVKGDKADETYVLGKIKDIYTQDGYDAFMKIYKKD
 KSKFLMYRHDPQTFEKVIEPILENYPNKQINEKGKEVPCNPFLKYKEEHGYIRKYSKKN
 GPEIKSLKYYDSKLGHNHIDITPKDSNNKVVLQSVSPWRADVFNKTTGKYEILGLKYAD
 LQFEKGTGTYKISQEKYNDIKKKEGVDSSEFKFTLYKNDLLLVKDTETKEQQLFRFLSR
 TMPKQKHVELKPYDKQKPEGGEALIKVLGNVANSQGCKKGLGKSNI SIYKVRTDVLG
 NQHI IKNEGDKPKLDFKRPAATKKAGQAKKKK

U6-St_tracrRNA (7-97) : (SEQ ID NO: 53)

GAGGGCCTATTTCCCATGATTCCTTCATATTTGCATATACGATACAAGGCT
 GTTAGAGAGATAAATGGAATTAATTTGACTGTAAACACAAGATATTAGTACAAAA
 TACGTGACGTAGAAAGTAATAATTTCTTGGGTAGTTGCAGTTTTAAATATGTTTT
 AAAATGGACTATCATATGCTTACCGTAACTGAAAGTATTCGATTTCTTGGCTTTAT
 ATATCTTGTGAAAGGACGAAACACCGTTACTTAAATCTTGCAGAAGCTACAAGA
 TAAGGCTTCATGCCGAAATCAACACCCGTGATTTTATGGCAGGGTGTTCGTTATT
 TAA

U6-DR-spacer-DR (*S. pyogenes* SF370) (SEQ ID NO: 54)

gagggcctatttcccatgattccttcattatattgcatatacgatacaaggctgtagaga
 gataattggaattaatttgactgtaaacacaaagatattagtacaaaatacgtgacgta
 gaaagtaataatcttgggtagtttgcagttttaaattatgttttaaaggactat
 catatgcttaccgtaacttgaaagtatttcgatttcttggctttatatacttggtaa
 aggacgaaacacgggttttagagctatgctgtttgaatggtcccaaacNNNNNNNN
 NNNNNNNNNNNNNNNNNNNgtttagagctatgctgtttgaatggtcccaaac

TTTTTTT (lowercase underline = direct repeat; N = guide sequence;
 bold = terminator)

Chimeric RNA containing +48 tracr RNA (*S. pyogenes* SF370) (SEQ ID NO: 55)

gagggcctatttcccatgattccttcattatattgcatatacgatacaaggctgtagagag
 ataattggaattaatttgactgtaaacacaaagatattagtacaaaatacgtgacgtaga
 aagtaataatcttgggtagtttgcagttttaaattatgttttaaaggactatcat

-continued

TGCAGCGATGGGGGCGGGGGGGGGGGGGGGGGGGCGCGCCAGGCGGGGCGGGGCGG
GGCGAGGGGGCGGGGCGGGGCGAGGCGGAGAGGTGCGGCGGCAGCCAATCAGAGCG
GCGCGCTCCGAAAGTTTCCTTTTATGGCGAGGCGGCGGCGGGCGGCCCTATAAA
AAGCGAAGCGCGCGGGGGGAGTGCCTGCGACGCTGCCTTCGCCCCGTGCCCC
GCTCCCGCCCGCCTCGCGCCCGCCCGCCCGGCTCTGACTGACCGGTTACTCCAC
AGGTGAGCGGGCGGACGCGCCCTTCTCCTCCGGGCTGTAATTAGCTGAGCAAGAGG
TAAGGGTTTAAGGGATGGTTGGTTGGTGGGTATTAATGTTAATTACCTGGAGCAC
CTGCCTGAAATCACTTTTTTTCAGGTTGGaccggtgceaccATGGACTATAAGGACCACGA
CGGAGACTACAAGGATCATGATATTGATTACAAGACGATGACGATAAGATGGCCC
CAAAGAAGAAGCGAAGGTCGGTATCCACGGAGTCCAGCAGCCGACAAGAAGTA
CAGCATCGGCCTGGACATCGGCACCAACTCTGTGGGCTGGGCCGTGATCACCGACG
AGTACAAGGTGCCAGCAAGAAATTCAAGGTGCTGGCAACACCGACCGGCACAGC
ATCAAGAAGAACCTGATCGGAGCCCTGTGTTCGACAGCGGCGAAACAGCCGAGGC
CACCCGGCTGAAGAGAACC GCCAGAAGAAGATACACCAGACGGAAGAACC GGATC
TGCTATCTGCAAGAGATCTTCAGCAACGAGATGGCCAAGGTGGACGACAGCTTCTTC
CACAGACTGGAAGAGTCCTTCTGGTGAAGAGGATAAGAAGCACGAGCGGCACCC
CATCTTCGGCAACATCGTGGACGAGGTGGCCTACCACGAGAAGTACCCACCATCT
ACCACCTGAGAAAGAAACTGGTGGACAGCACCGACAAGGCCGACCTGCGGCTGATC
TATCTGGCCCTGGCCACATGATCAAGTTCGGGGCCACTTCTCTGATCGAGGGCGAC
CTGAACCCCGACAACAGCGACGTGGACAAGCTGTTCATCCAGCTGGTGCAGACCTA
CAACCAGCTGTTTCGAGGAAAACCCCATCAACGCCAGCGCGTGGACGCAAGGCCA
TCCTGTCTGCCAGACTGAGCAAGAGCAGACGGCTGGAAAATCTGATCGCCAGCTG
CCCGGCGAGAAGAAGAAATGGCCTGTTCGGCAACC TGATGCCCTGAGCCTGGGCCT
GACCCCAACTTCAAGAGCAACTTCGACCTGGCCGAGGATGCCAAACTGCAGCTGA
GCAAGGACACCTACGACGACGACCTGGACAACCTGCTGGCCAGATCGGCGACCAG
TACGCGACCTGTTTCTGGCCCAAGAACCCTGTCCGACGCCATCCTGCTGAGCGAC
ATCCTGAGAGTGAACACCGAGATCACCAGGCCCCCTGAGCGCCTCTATGATCAA
GAGATACGACGAGCACCAAGGACCTGACCTGCTGAAAGCTCTCGTCCGGCAGC
AGCTGCTGAGAAGTACAAGAGATTTTCTTCGACCAGAGCAAGAACGGCTACGCC
GGCTACATTGACGGCGGAGCCAGCCAGGAAGAGTTCTACAAGTTTCATCAAGCCAT
CCTGGAAGAAGTGGACGGCACCGGAACTGCTCGTGAAGCTGAACAGAGAGGAC
CTGCTGCGGAAGCAGCGGACCTTCGACAACGGCAGCATCCCCACCAGATCCACCT
GGGAGAGCTGCACGCCATTCTGCGGCGGAGGAGATTTTACCCATTCTGAAGG
ACAACCGGAAAAGATCGAGAAGATCTGACCTTCCGCATCCCTACTACGTGGGC
CCTCTGGCCAGGGGAAACAGCAGATTCGCCCTGGATGACCAGAAAAGAGCGAGGAAA
CCATACCCCCTGAACTTCGAGGAAGTGGTGGACAAGGGCGCTTCCGCCAGAGC
TTCATCGAGCGGATGACCAACTTCGATAAGAACC TGCCAACGAGAAGGTGCTGCC
CAAGCACAGCCTGCTGTACGAGTACTTCACCGTGTATAACGAGCTGACCAAAGTGA
AATACGTGACCGAGGAATGAGAAAGCCCGCCTTCTGAGCGCGGAGCAGAAAAA

-continued

GGCCATCGTGGACCTGCTGTTCAAGACCAACCGGAAAGTGACCGTGAAGCAGCTGA
AAGAGGACTACTTCAAGAAAATCGAGTGCTTCGACTCCGTGGAAATCTCCGGCGTG
GAAGATCGGTTCAACGCCTCCCTGGGCACATACCACGATCTGCTGAAAATTATCAAG
GACAAGGACTTCTGGACAATGAGGAAAACGAGGACATCTGGAAGATATCGTGCT
GACCCTGACACTGTTTGAGGACAGAGAGATGATCGAGGAACGGCTGAAAACCTATG
CCCACCTGTTTCGACGACAAAGTGATGAAGCAGCTGAAGCGGCGGAGATACACCGGC
TGGGGCAGGCTGAGCCGGAAGCTGATCAACGGCATCCGGGACAAGCAGTCCGGCAA
GACAATCCTGGATTTCTGAAAGTCCGACGGCTTCGCCAACAGAACTTCATGCAGCT
GATCCACGACGACAGCCTGACCTTTAAAGAGGACATCCAGAAAGCCAGGTGTCCG
GCCAGGGCGATAGCCTGCACGAGCACATTGCCAATCTGGCCGGCAGCCCGCCATT
AAGAAGGGCATCCTGCAGACAGTGAAGGTGGTGGACGAGCTCGTAAAAGTGATGGG
CCGGCACAAGCCCAGAACATCGTGATCGAAATGGCCAGAGAGAACCAGACCACC
AGAAGGGACAGAAGAACAGCCCGGAGAGAAATGAAGCGGATCGAAGAGGGCATCAA
AGAGCTGGGCAGCCAGATCCTGAAAGAACACCCCGTGGAAAACACCCAGCTGCAGA
ACGAGAAGCTGTACTGTACTACCTGCAGAAATGGCGGGATATGTACGTGGACCAG
GAACTGGACATCAACCGGCTGTCCGACTACGATGTGGACCATATCGTGCCTCAGAG
CTTTCTGAAGGACGACTCCATCGACAACAAGGTGCTGACCAGAAGCGACAAGAACC
GGGGCAAGAGCGACAACGTGCCCTCCGAAGAGGTCTGAAGAAGATGAAGAACTA
CTGGCGGCAGCTGCTGAACGCCAAGCTGATTACCCAGAGAAAGTTCGACAATCTGA
CCAAGGCCGAGAGAGGGCGGCTGAGCGAACTGGATAAGGCCGGCTTCATCAAGAG
ACAGTGGTGGAAACCCGGCAGATCACAAAGCACGTGGCACAGATCCTGGACTCCC
GGATGAACACTAAGTACGACGAGAAATGACAAGCTGATCCGGGAAGTGAAGTGATC
ACCCGAAAGTCCAAGCTGGTGTCCGATTTCCGGAAGGATTTCCAGTTTTACAAAAGTG
CGCGAGATCAACAATACCACCACGCCACGACGCTTACCTGAACGCCGCTCGTGGG
AACCGCCCTGATCAAAAAGTACCCTAAGCTGGAAAGCGAGTTCGTGTACGGCGACT
ACAAGGTGTACGACGTGCGGAAGATGATCGCCAAGAGCGAGCAGGAAATCGGCAA
GGCTACGCCCAAGTACTTCTTCTACAGCAACATCATGAATTTTTCAAGACCGAGAT
TACCCTGGCCAACGGCGAGATCCGGAAGCGGCTCTGATCGAGACAAACGGCGAAA
CCGGGGAGATCGTGTGGGATAAGGGCCGGGATTTTGCCACCGTGCAGAAAGTGCTG
AGCATGCCCAAGTGAATATCGTGAAAAGACCGAGGTGCAGACAGGCGGCTTCAG
CAAAGAGTCTATCTGCCCCAAGAGGAACAGCGATAAGCTGATCGCCAGAAAGAGG
ACTGGGACCCTAAGAAGTACGGCGGCTTCGACAGCCCCACCGTGGCTATTCTGTGC
TGGTGGTGGCCAAAGTGGAAAAGGGCAAGTCCAAGAACTGAAGAGTGTGAAAGA
GCTGTGGGGATCACCATCATGAAAAGAAGCAGCTTCGAGAAGAATCCCATCGACT
TTCTGGAAGCCAAGGGCTACAAAGAAGTAAAAGGACCTGATCATCAAGCTGCCT
AAGTACTCCCTGTTTCGAGCTGGAAAACGGCCGGAAGAGAATGCTGGCCTCTGCCGG
CGAATGCAGAAGGGAAAACGAACTGGCCCTGCCCTCCAAATATGTGAACTTCTGT
ACCTGGCCAGCCACTATGAGAAGCTGAAGGGCTCCCCGAGGATAATGAGCAGAAA
CAGCTGTTTGTGGAACAGCACAGCACTACCTGGACGAGATCATCGAGCAGATCAG

-continued

CGAGTTCTCCAAGAGAGTGATCCTGGCCGACGCTAATCTGGACAAAGTGCTGTCCGC
CTACAACAAGCACCCGGGATAAGCCCATCAGAGAGCAGGCCGAGAATATCATCCACC
TGTTTACCCTGACCAATCTGGGAGCCCTGCCGCCTTCAAGTACTTTGACACCACCA
TCGACCCGAAGAGGTACACCAGCACCAAGAGGTGCTGGACGCCACCCTGATCCAC
CAGAGCATCACCGCCTGTACGAGACACGGATCGACCTGTCTCAGCTGGGAGGCGA
CTTTCTTTTCTTAGCTTGACCAGCTTTCTTAGTAGCAGCAGGACGCTTTAA

(underline = NLS-hSpCas9-NLS)

[0237] Example chimeric RNA for *S. thermophilus*
 LMD-9 CRISPR1 Cas9 (with PAM of NNAGAAW)

(SEQ ID NO: 21)

NNNNNNNNNNNNNNNNNNNNNNNNNNNNgtttttgtactctcaagatttaGAAAtaaa
tcttgcagaagctacaaaagataaaggcttcatgccgaaatcaacaccctgt
cattttatggcagggtgttttcggtatttaaTTTTTT (N = guide

sequence; first underline = tracr mate

sequence; second underline = tracr sequence;

bold = terminator)

[0238] Example chimeric RNA for *S. thermophilus*
 LMD-9 CRISPR1 Cas9 (with PAM of NNAGAAW)

(SEQ ID NO: 22)

NNNNNNNNNNNNNNNNNNNNNNNNNNNNgtttttgtactctcaGAAAtgcagaagcta
caaaagataaaggcttcatgccgaaatcaacaccctgtcattttatggcagg
gtgttttcggtatttaaTTTTTT (N = guidesequence;

first underline = tracr mate sequence;

second underline = tracr sequence;

bold = terminator)

[0239] Example chimeric RNA for *S. thermophilus*
 LMD-9 CRISPR1 Cas9 (with PAM of NNAGAAW)

(SEQ ID NO: 23)

NNNNNNNNNNNNNNNNNNNNNNNNNNNNgtttttgtactctcaGAAAtgcagaagcta
caaaagataaaggcttcatgccgaaatcaacaccctgtcattttatggcagg
gtgtTTTTTT (N = guide sequence; firstunderline =

tracr mate sequence; second underline = tracr

sequence; bold = terminator)

[0240] Example chimeric RNA for *S. thermophilus*
 LMD-9 CRISPR1 Cas9 (with PAM of NNAGAAW)

(SEQ ID NO: 60)

NNNNNNNNNNNNNNNNNNNNNNNNNNNNgttattgtactctcaagatttaGAAAtaaa
tcttgcagaagctacaaaagataaaggcttcatgccgaaatcaacaccctgt
cattttatggcagggtgttttcggtatttaaTTTTTT (N =guide

sequence; first underline = tracr mate

sequence; second underline = tracr sequence;

bold = terminator)

[0241] Example chimeric RNA for *S. thermophilus*
 LMD-9 CRISPR1 Cas9 (with PAM of NNAGAAW)

(SEQ ID NO: 61)

NNNNNNNNNNNNNNNNNNNNNNNNNNNNgttattgtactctcaGAAAtgcagaagcta
caaaagataaaggcttcatgccgaaatcaacaccctgtcattttatggcagg
gtgttttcggtatttaaTTTTTT (N = guidesequence;

first underline = tracr mate sequence;

second underline = tracr sequence;

bold = terminator)

[0242] Example chimeric RNA for *S. thermophilus*
 LMD-9 CRISPR1 Cas9 (with PAM of NNAGAAW)

(SEQ ID NO: 62)

NNNNNNNNNNNNNNNNNNNNNNNNNNNNgttattgtactctcaGAAAtgcagaagcta
caaaagataaaggcttcatgccgaaatcaacaccctgtcattttatggcagg
gtgtTTTTTT (N = guide sequence; firstunderline =

tracr mate sequence; second underline = tracr

sequence; bold = terminator)

[0243] Example chimeric RNA for *S. thermophilus* LMD-9 CRISPR1 Cas9 (with PAM of NNAGAAW)

(SEQ ID NO: 63)
NNNNNNNNNNNNNNNNNNNNNNgttattgtactctcaagatttaGAAAtaa
tcttgacagaagctacaatgataaggcttcatgcccgaatcaacaccctgt
cattttatggcagqgtgttttcgattattaaTTTTTT (N =guide
sequence; first underline = tracr mate
sequence; second underline = tracr sequence;
bold = terminator)

[0244] Example chimeric RNA for *S. thermophilus* LMD-9 CRISPR1 Cas9 (with PAM of NNAGAAW)

(SEQ ID NO: 64)
NNNNNNNNNNNNNNNNNNNNNNgttattgtactctcaGAAAtgcagaagcta
caatgataaggcttcatgcccgaatcaacaccctgtcattttatggcagq
gtgttttcgattattaaTTTTTT (N = guidesequence;
first underline = tracr mate sequence; second
underline = tracr sequence; bold =
terminator)

[0245] Example chimeric RNA for *S. thermophilus* LMD-9 CRISPR1 Cas9 (with PAM of NNAGAAW)

(SEQ ID NO: 65)
NNNNNNNNNNNNNNNNNNNNNNgttattgtactctcaGAAAtgcagaagcta
caatgataaggcttcatgcccgaatcaacaccctgtcattttatggcagq
gtgtTTTTTT (N = guide sequence; firstunderline =
tracr mate sequence; second underline = tracr
sequence; bold = terminator)

[0246] Example chimeric RNA for *S. thermophilus* LMD-9 CRISPR3 Cas9 (with PAM of NGGNG)

(SEQ ID NO: 66)
NNNNNNNNNNNNNNNNNNNNNNgttttagagctgtgGAAAcacagcagtta
aaataaaggcttagtccgtactcaacttgaaaaggtggcaccgattcgggtg
TTTTTTT (N = guide sequence; firstunderline =
tracr mate sequence; second underline = tracr
sequence; bold = terminator)

[0247] Codon-optimized version of Cas9 from *S. thermo-philus* LMD-9 CRISPR3 locus (with an NLS at both 5' and 3' ends)

(SEQ ID NO: 67)
ATGAAAGGCCCGCGCCACGAAAAAGGCCCGCCAGGCAAAAAGAAAA
GACCAAGCCCTACAGCATCGGCCCTGGACATCGGCACCAATAGCGTGGGCT
GGCCCGTGACCACCGACAACACTACAAGGTGCCAGCAAGAAAATGAAGGTG

-continued

CTGGGCAACACCTCCAAGAAGTACATCAAGAAAAACCTGCTGGGCGTGCT
GCTGTTTCGACAGCGCATTACAGCCGAGGGCAGACCGGCTGAAGAGAACCG
CCAGACGGCGGTACACCCGGCGGAGAAACAGAATCCTGTATCTGCAAGAG
ATCTTCAGCACCGAGATGGCTACCCTGGACGACGCTTCTTCCAGCGGCT
GGACGACAGCTTCTGTTGCCCGACGACAAGCGGGACAGCAAGTACCCCA
TCTTCGGCAACCTGGTGAAGAGAAGGCCCTACCACGACGAGTTCCCCACC
ATCTACCACCTGAGAAAGTACCTGGCCGACGACCAAGAAGGCCGACCT
GAGACTGGTGTATCTGGCCCTGGCCACATGATCAAGTACCGGGGCCACT
TCCTGATCGAGGGCGAGTTCAACAGCAAGAACAACGACATCCAGAAGAAC
TTCCAGGACTTCTGGACACCTACAACGCCATCTTCGAGAGCGACTGTG
CCTGGAAAAACAGCAAGCAGCTGGAAGAGATCGTGAAGACAAGATCAGCA
AGCTGGAAAAGAAGGACCGCATCCTGAAGCTGTTCCCGCGGAGAAGAAC
AGCGGAATCTTCAGCGAGTTTCTGAAGCTGATCGTGGGCAACCAGGCCGA
CTTCAGAAAAGTGCTTCAACCTGGACGAGAAAGCCAGCCTGCACCTTCAGCA
AAGAGAGCTACGACGAGGACCTGGAAACCTGCTGGGATATATCGGCGAC
GACTACAGCGACGTGTTCTGAAGGCCAAGAAGCTGTACGACGCTATCCT
GCTGAGCGGCTTCTGACCGTGACCGACAACGAGACAGAGGCCCCACTGA
GCAGCGCCATGATTAAGCGGTACAACGAGCACAAAGAGGATCTGGCTCTG
CTGAAAAGTACATCCGGAACATCAGCCTGAAAACCTACAATGAGGTGTT
CAAGGACGACACCAAGAACGGCTACGCCGGCTACATCGACGGCAAGACCA
ACCAGGAAGATTTCTATGTGTACCTGAAGAAGCTGCTGGCCGAGTTCGAG
GGGGCCGACTACTTCTGGAAAAAATCGACCCGAGGATTTCTGCGGAA
GCAGCGGACCTTCGACAACGGCAGCATCCCCTACCAGATCCATCTGCAGG
AAATGCGGGCCATCCTGGACAAGCAGGCCAAGTTCTACCCATTCTGGCC
AAGAACAAGAGCGGATCGAGAAGATCCTGACCTTCGCGATCCCTTACTA
CGTGGGCCCCCTGGCCAGAGGCAACAGCGATTTTGCCTGGTCCATCCGGA
AGCGCAATGAGAAGATCACCCCTGGAACCTCGAGGACGTGATCGACAAA
GAGTCCAGCGCCGAGGCCTTCATCAACCGGATGACCAGCTTCGACCTGTA
CCTGCCCAGGAAAAGGTGCTGCCCAAGCACAGCCTGCTGTACGAGACAT
TCAATGTGTATAACGAGCTGACCAAAGTGCGGTTTATCGCCGAGTCTATG
CGGGACTACCAGTTCCTGGACTCCAAGCAGAAAAGGACATCGTGGCGCT
GTACTTCAAGGACAAGCGGAAAGTGACCATAAGGACATCATCGAGTACC
TGCACGCCATCTACGGCTACGATGGCATCGAGCTGAAGGGCATCGAGAAG
CAGTTCAACTCCAGCCTGAGCACATACCACGACCTGCTGAACATTATCAA
CGACAAAAGATTTCTGGACGACTCCAGCAACGAGGCCATCATCGAAGAGA
TCATCCACACCTGACCATCTTTGAGGACCCGAGATGATCAAGCAGCGG
CTGAGCAAGTTCCGAGAACATCTTCGACAAGAGCGTGTGAAAAAGCTGAG
CAGACGGCACTACACCGGCTGGGGCAAGCTGAGCGCCAAGCTGATCAACG
GCATCCGGGACGAGAAGTCCGGCAACACAATCCTGGACTACCTGATCGAC

-continued

GACGGCATCAGCAACCGGAAC TTCATGCAGCTGATCCACGACGACGCCTT
 GAGCTTCAAGAAGAAGATCCAGAAGGCCAGATCATCGGGGACGAGGACA
 AGGGCAACATCAAAGAAGTCGTGAAGTCCCTGCCCGGACGCCGCCATC
 AAGAAGGGAATCCTGCAGAGCATCAAGATCGTGGACGAGCTCGTAAAAGT
 GATGGGCGGCAGAAAAGCCGAGAGCATCGTGGTGGAAATGGCTAGAGAGA
 ACCAGTACACCAATCAGGGCAAGAGCAACAGCCAGCAGAGACTGAAGAGA
 CTGGAAGTCCCTGAAAGAGCTGGGCAGCAAGATTCTGAAAGAGAATAT
 CCCTGCCAAGCTGTCCAAGATCGACAACAACGCCCTGCAGAACGACCGGC
 TGTACCTGTACTACCTGCAGAATGGCAAGGACATGTATACAGCGCAGCAGC
 CTGGATATCGACCGCTGAGCAACTACGACATCGACCATATTATCCCCCA
 GGCCTTCTGAAAGACAACAGCATTGACAACAAGTGTGGTGTCTCTCG
 CCAGCAACCGCGGCAAGTCCGATGATGTGCCAGCCTGGAAGTCGTGAAA
 AAGAGAAAGACCTTCTGGTATCAGCTGTGAAAAGCAAGCTGATTAGCCA
 GAGGAAGTTCGACAACCTGACCAAGGCCGAGAGGGCGGCTGAGCCCTG
 AAGATAAGGCCGGCTTCATCCAGAGACAGCTGGTGGAAACCCGGCAGATC
 ACCAAGCAGCTGGCCAGACTGCTGGATGAGAAGTTTAAACAACAAGAGGA
 CGAGAACAAACCGGGCCGTGCGGACCGTGAAGATCATCACCTGAAGTCCA
 CCCTGGTGTCCAGTTCGGGAAGGACTTCGAGCTGTATAAAGTGCAGCAG
 ATCAATGACTTTCACCACGCCCACGACGCTACCTGAATGCCGTGGTGGC
 TTCCGCCCTGCTGAAGAAGTACCCTAAGCTGGAAACCCGAGTTCGTGTACG
 GCGACTACCCCAAGTACAACCTCCTCAGAGAGCGGAAGTCCGCCACCGAG
 AAGGTGTACTTCTACTCCAACATCATGAATATCTTTAAGAAGTCCATCTC
 CCTGGCCGATGGCAGAGTATCGAGCGGCCCTGATCGAAGTGAACGAAG
 AGACAGGCGAGAGCGTGTGGAACAAGAAAGCGACCTGGCCACCGTGCAG
 CGGGTGTGAGTTATCCTCAAGTGAATGCTGTAAGAAGGTGGAAGAACA
 GAACCACGGCCTGGATCGGGCAAGCCCAAGGGCTGTTCAACGCCAACCC
 TGTCCAGCAAGCCTAAGCCAACTCCAACGAGAATCTCGTGGGGGCCAAA
 GAGTACCTGGACCCTAAGAAGTACGGCGGATACGCCGATCTCCAATAG
 CTTCACCGTGTCTGTGAAGGCGACAATCGAGAAGGGCGCTAAGAAAAAGA
 TCACAACAGTGTGGAATTTAGGGGATCTCTATCCTGGACCGGATCAAC
 TACCGGAAGGATAAGCTGAACTTTCTGTGGAAGGCTACAAGGACAT
 TGAGCTGATTATCGAGCTGCCAAGTACTCCCTGTTTCAAGTGCAGCAGC
 GCTCCAGACGGATGTGGCCTCCATCCTGTCCACCAACAACAGCGGGGC
 GAGATCCACAAGGGAAACAGATCTTCTGAGCCAGAAATTTGTGAAACT
 GCTGTACCACGCCAAGCGGATCTCCAACACCATCAATGAGAACCACCGGA
 AATACGTGGAAGAACACAAGAAAGAGTTTGAGGAAGTGTCTACTACATC
 CTGGAGTTCAACGAGAATATGTGGGAGCCAAGAAGAACGGCAAAGTCTG
 GAACTCCGCCCTTCCAGAGCTGGCAGAACACAGCATCGACGAGCTGTGCA
 GCTCCTTCATCGGCCCTACCGCAGCGAGCGGAAGGACTGTTTGAGCTG

-continued

ACCTCCAGAGGCTCTGCCCGGACTTTGAGTTCCTGGGAGTGAAGATCCC
 CCGGTACAGAGACTACACCCCTCTAGTCTGCTGAAGGACGCCACCCCTGA
 TCCACCAGAGCGTGACCGGCTGTACGAAACCCGGATCGACCTGGCTAAG
 CTGGGCGAGGAAAGCGTCTGCTGCTACTAAGAAAGCTGGTCAAGCTAA
 GAAAAAGAAATAA

Example 5: RNA-Guided Editing of Bacterial Genomes Using CRISPR-Cas Systems

[0248] Applicants used the CRISPR-associated endonuclease Cas9 to introduce precise mutations in the genomes of *Streptococcus pneumoniae* and *Escherichia coli*. The approach relied on Cas9-directed cleavage at the targeted site to kill unmutated cells and circumvented the need for selectable markers or counter-selection systems. Cas9 specificity was reprogrammed by changing the sequence of short CRISPR RNA (crRNA) to make single- and multi-nucleotide changes carried on editing templates. Simultaneous use of two crRNAs enabled multiplex mutagenesis. In *S. pneumoniae*, nearly 100% of cells that survived Cas9 cleavage contained the desired mutation, and 65% when used in combination with recombineering in *E. coli*. Applicants exhaustively analyzed Cas9 target requirements to define the range of targetable sequences and showed strategies for editing sites that do not meet these requirements, suggesting the versatility of this technique for bacterial genome engineering.

[0249] The understanding of gene function depends on the possibility of altering DNA sequences within the cell in a controlled fashion. Site-specific mutagenesis in eukaryotes is achieved by the use of sequence-specific nucleases that promote homologous recombination of a template DNA containing the mutation of interest. Zinc finger nucleases (ZFNs), transcription activator-like effector nucleases (TALENs) and homing meganucleases can be programmed to cleave genomes in specific locations, but these approaches require engineering of new enzymes for each target sequence. In prokaryotic organisms, mutagenesis methods either introduce a selection marker in the edited locus or require a two-step process that includes a counter-selection system. More recently, phage recombination proteins have been used for recombineering, a technique that promotes homologous recombination of linear DNA or oligonucleotides. However, because there is no selection of mutations, recombineering efficiency can be relatively low (0.1-10% for point mutations down to 10⁻⁵-10⁻⁶ for larger modifications), in many cases requiring the screening of a large number of colonies. Therefore new technologies that are affordable, easy to use and efficient are still in need for the genetic engineering of both eukaryotic and prokaryotic organisms.

[0250] Recent work on the CRISPR (clustered, regularly interspaced, short palindromic repeats) adaptive immune system of prokaryotes has led to the identification of nucleases whose sequence specificity is programmed by small RNAs. CRISPR loci are composed of a series of repeats separated by 'spacer' sequences that match the genomes of bacteriophages and other mobile genetic elements. The repeat-spacer array is transcribed as a long precursor and processed within repeat sequences to generate small crRNA

that specify the target sequences (also known as protospacers) cleaved by CRISPR systems. Essential for cleavage is the presence of a sequence motif immediately downstream of the target region, known as the protospacer-adjacent motif (PAM). CRISPR-associated (cas) genes usually flank the repeat-spacer array and encode the enzymatic machinery responsible for crRNA biogenesis and targeting. Cas9 is a dsDNA endonuclease that uses a crRNA guide to specify the site of cleavage. Loading of the crRNA guide onto Cas9 occurs during the processing of the crRNA precursor and requires a small RNA antisense to the precursor, the tracrRNA, and RNase III. In contrast to genome editing with ZFNs or TALENs, changing Cas9 target specificity does not require protein engineering but only the design of the short crRNA guide.

[0251] Applicants recently showed in *S. pneumoniae* that the introduction of a CRISPR system targeting a chromosomal locus leads to the killing of the transformed cells. It was observed that occasional survivors contained mutations in the target region, suggesting that Cas9 dsDNA endonuclease activity against endogenous targets could be used for genome editing. Applicants showed that marker-less mutations can be introduced through the transformation of a template DNA fragment that will recombine in the genome and eliminate Cas9 target recognition. Directing the specificity of Cas9 with several different crRNAs allows for the introduction of multiple mutations at the same time. Applicants also characterized in detail the sequence requirements for Cas9 targeting and show that the approach can be combined with recombineering for genome editing in *E. coli*.

[0252] RESULTS: Genome Editing by Cas9 Cleavage of a Chromosomal Target

[0253] *S. pneumoniae* strain crR6 contains a Cas9-based CRISPR system that cleaves a target sequence present in the bacteriophage ϕ 8232.5. This target was integrated into the *srtA* chromosomal locus of a second strain R6^{8232.5}. An altered target sequence containing a mutation in the PAM region was integrated into the *srtA* locus of a third strain R6^{370.1}, rendering this strain 'immune' to CRISPR cleavage (FIG. 28a). Applicants transformed R6^{8232.5} and R6^{370.1} cells with genomic DNA from crR6 cells, expecting that successful transformation of R6^{8232.5} cells should lead to cleavage of the target locus and cell death. Contrary to this expectation, Applicants isolated R6^{8232.5} transformants, albeit with approximately 10-fold less efficiency than R6^{370.1} transformants (FIG. 28b). Genetic analysis of eight R6^{8232.5} transformants (FIG. 28) revealed that the great majority are the product of a double recombination event that eliminates the toxicity of Cas9 targeting by replacing the ϕ 8232.5 target with the crR6 genome's wild-type *srtA* locus, which does not contain the protospacer required for Cas9 recognition. These results were proof that the concurrent introduction of a CRISPR system targeting a genomic locus (the targeting construct) together with a template for recombination into the targeted locus (the editing template) led to targeted genome editing (FIG. 23a).

[0254] To create a simplified system for genome editing, Applicants modified the CRISPR locus in strain crR6 by deleting *cas1*, *cas2* and *csn2*, genes which have been shown to be dispensable for CRISPR targeting, yielding strain crR6M (FIG. 28a). This strain retained the same properties of crR6 (FIG. 28b). To increase the efficiency of Cas9-based editing and demonstrate that a template DNA of choice can

be used to control the mutation introduced, Applicants co-transformed R6^{8232.5} cells with PCR products of the wild-type *srtA* gene or the mutant R6^{370.1} target, either of which should be resistant to cleavage by Cas9. This resulted in a 5- to 10-fold increase of the frequency of transformation compared with genomic crR6 DNA alone (FIG. 23b). The efficiency of editing was also substantially increased, with 8/8 transformants tested containing a wild-type *srtA* copy and 7/8 containing the PAM mutation present in the R6^{370.1} target (FIG. 23b and FIG. 29a). Taken together, these results showed the potential of genome editing assisted by Cas9.

[0255] Analysis of Cas9 Target Requirements:

[0256] To introduce specific changes in the genome, one must use an editing template carrying mutations that abolish Cas9-mediated cleavage, thereby preventing cell death. This is easy to achieve when the deletion of the target or its replacement by another sequence (gene insertion) is sought. When the goal is to produce gene fusions or to generate single-nucleotide mutations, the abolishment of Cas9 nuclease activity will only be possible by introducing mutations in the editing template that alter either the PAM or the protospacer sequences. To determine the constraints of CRISPR-mediated editing, Applicants performed an exhaustive analysis of PAM and protospacer mutations that abrogate CRISPR targeting.

[0257] Previous studies proposed that *S. pyogenes* Cas9 requires an NGG PAM immediately downstream of the protospacer. However, because only a very limited number of PAM-inactivating mutations have been described so far, Applicants conducted a systematic analysis to find all 5-nucleotide sequences following the protospacer that eliminate CRISPR cleavage. Applicants used randomized oligonucleotides to generate all possible 1,024 PAM sequences in a heterogeneous PCR product that was transformed into crR6 or R6 cells. Constructs carrying functional PAMs were expected to be recognized and destroyed by Cas9 in crR6 but not R6 cells (FIG. 24a). More than 2×10^5 colonies were pooled together to extract DNA for use as template for the co-amplification of all targets. PCR products were deep sequenced and found to contain all 1,024 sequences, with coverage ranging from 5 to 42,472 reads (See section "Analysis of deep sequencing data"). The functionality of each PAM was estimated by the relative proportion of its reads in the crR6 sample over the R6 sample. Analysis of the first three bases of the PAM, averaging over the two last bases, clearly showed that the NGG pattern was under-represented in crR6 transformants (FIG. 24b). Furthermore, the next two bases had no detectable effect on the NGG PAM (See section "Analysis of deep sequencing data"), demonstrating that the NGGNN sequence was sufficient to license Cas9 activity. Partial targeting was observed for NAG PAM sequences (FIG. 24b). Also the NNGGN pattern partially inactivated CRISPR targeting (Table G), indicating that the NGG motif can still be recognized by Cas9 with reduced efficiency when shifted by 1 bp. These data shed light onto the molecular mechanism of Cas9 target recognition, and they revealed that NGG (or CCN on the complementary strand) sequences are sufficient for Cas9 targeting and that NGG to NAG or NNGGN mutations in the editing template should be avoided. Owing to the high frequency of these tri-nucleotide sequences (once every 8 bp), this means that almost any position of the genome can be edited. Indeed, Applicants tested ten randomly chosen targets carrying various PAMs and all were found to be functional (FIG. 30).

[0258] Another way to disrupt Cas9-mediated cleavage is to introduce mutations in the protospacer region of the editing template. It is known that point mutations within the 'seed sequence' (the 8 to 10 protospacer nucleotides immediately adjacent to the PAM) can abolish cleavage by CRISPR nucleases. However, the exact length of this region is not known, and it is unclear whether mutations to any nucleotide in the seed can disrupt Cas9 target recognition. Applicants followed the same deep sequencing approach described above to randomize the entire protospacer sequence involved in base pair contacts with the crRNA and to determine all sequences that disrupt targeting. Each position of the 20 matching nucleotides (14) in the *speI* target present in R6^{8232.5} cells (FIG. 23a) was randomized and transformed into crR6 and R6 cells (FIG. 24a). Consistent with the presence of a seed sequence, only mutations in the 12 nucleotides immediately upstream of the PAM abrogated cleavage by Cas9 (FIG. 24c). However, different mutations displayed markedly different effects. The distal (from the PAM) positions of the seed (12 to 7) tolerated most mutations and only one particular base substitution abrogated targeting. In contrast, mutations to any nucleotide in the proximal positions (6 to 1, except 3) eliminated Cas9 activity, although at different levels for each particular substitution. At position 3, only two substitutions affected CRISPR activity and with different strength. Applicants concluded that, although seed sequence mutations can prevent CRISPR targeting, there are restrictions regarding the nucleotide changes that can be made in each position of the seed. Moreover, these restrictions can most likely vary for different spacer sequences. Therefore Applicants believe that mutations in the PAM sequence, if possible, should be the preferred editing strategy. Alternatively, multiple mutations in the seed sequence may be introduced to prevent Cas9 nuclease activity.

[0259] Cas9-Mediated Genome Editing in *S. pneumoniae*:

[0260] To develop a rapid and efficient method for targeted genome editing, Applicants engineered strain crR6Rk, a strain in which spacers can be easily introduced by PCR (FIG. 33). Applicants decided to edit the 3-galactosidase (*bgaA*) gene of *S. pneumoniae*, whose activity can be easily measured. Applicants introduced alanine substitutions of amino acids in the active site of this enzyme: R481A (R→A) and N563A,E564A (NE→AA) mutations. To illustrate different editing strategies, Applicants designed mutations of both the PAM sequence and the protospacer seed. In both cases the same targeting construct with a crRNA complementary to a region of the β-galactosidase gene that is adjacent to a TGG PAM sequence (CCA in the complementary strand, FIG. 26) was used. The R→A editing template created a three-nucleotide mismatch on the protospacer seed sequence (CGT to GCA, also introducing a BtgZI restriction site). In the NE→AA editing template Applicants simultaneously introduced a synonymous mutation that created an inactive PAM (TGG to TTG) along with mutations that are 218 nt downstream of the protospacer region (AAT GAA to GCT GCA, also generating a TseI restriction site). This last editing strategy demonstrated the possibility of using a remote PAM to make mutations in places where a proper target may be hard to choose. For example, although the *S. pneumoniae* R6 genome, which has a 39.7% GC content, contains on average one PAM motif every 12 bp, some PAM motifs are separated by up to 194 bp (FIG. 33). In addition Applicants designed a Δ*bgaA* in-frame deletion of 6,664 bp.

In all three cases, co-transformation of the targeting and editing templates produced 10-times more kanamycin-resistant cells than co-transformation with a control editing template containing wild-type *bgaA* sequences (FIG. 25b). Applicants genotyped 24 transformants (8 for each editing experiment) and found that all but one incorporated the desired change (FIG. 25c). DNA sequencing also confirmed not only the presence of the introduced mutations but also the absence of secondary mutations in the target region (FIG. 29b,c). Finally, Applicants measured 3-galactosidase activity to confirm that all edited cells displayed the expected phenotype (FIG. 25d).

[0261] Cas9-mediated editing can also be used to generate multiple mutations for the study of biological pathways. Applicants decided to illustrate this for the sortase-dependent pathway that anchors surface proteins to the envelope of Gram-positive bacteria. Applicants introduced a sortase deletion by co-transformation of a chloramphenicol-resistant targeting construct and a Δ*srtA* editing template (FIG. 33a,b), followed by a Δ*bgaA* deletion using a kanamycin-resistant targeting construct that replaced the previous one. In *S. pneumoniae*, P3-galactosidase is covalently linked to the cell wall by sortase. Therefore, deletion of *srtA* results in the release of the surface protein into the supernatant, whereas the double deletion has no detectable 3-galactosidase activity (FIG. 34c). Such a sequential selection can be iterated as many times as required to generate multiple mutations.

[0262] These two mutations may also be introduced at the same time. Applicants designed a targeting construct containing two spacers, one matching *srtA* and the other matching *bgaA*, and co-transformed it with both editing templates at the same time (FIG. 25e). Genetic analysis of transformants showed that editing occurred in 6/8 cases (FIG. 25f). Notably, the remaining two clones each contained either a Δ*srtA* or a Δ*bgaA* deletion, suggesting the possibility of performing combinatorial mutagenesis using Cas9. Finally, to eliminate the CRISPR sequences, Applicants introduced a plasmid containing the *bgaA* target and a spectinomycin resistance gene along with genomic DNA from the wild-type strain R6. Spectinomycin-resistant transformants that retain the plasmid eliminated the CRISPR sequences (FIG. 34a,d).

[0263] Mechanism and Efficiency of Editing:

[0264] To understand the mechanisms underlying genome editing with Cas9, Applicants designed an experiment in which the editing efficiency was measured independently of Cas9 cleavage. Applicants integrated the *ermAM* erythromycin resistance gene in the *srtA* locus, and introduced a premature stop codon using Cas9-mediated editing (FIG. 33). The resulting strain (JEN53) contains an *ermAM*(stop) allele and is sensitive to erythromycin. This strain may be used to assess the efficiency at which the *ermAM* gene is repaired by measuring the fraction of cells that restore antibiotic resistance with or without the use of Cas9 cleavage. JEN53 was transformed with an editing template that restores the wild-type allele, together with either a kanamycin-resistant CRISPR construct targeting the *ermAM*(stop) allele (CRISPR::*ermAM*(stop)) or a control construct without a spacer (CRISPR::∅) (FIG. 26a,b). In the absence of kanamycin selection, the fraction of edited colonies was on the order of 10⁻² (erythromycin-resistant cfu/total cfu) (FIG. 26c), representing the baseline frequency of recombination without Cas9-mediated selection against unedited cells. However, if kanamycin selection was applied and the con-

trol CRISPR construct was co-transformed, the fraction of edited colonies increased to about 10^{-1} (kanamycin- and erythromycin-resistant cfu/kanamycin-resistant cfu) (FIG. 26c). This result shows that selection for the recombination of the CRISPR locus co-selected for recombination in the ermAM locus independently of Cas9 cleavage of the genome, suggesting that a subpopulation of cells is more prone to transformation and/or recombination. Transformation of the CRISPR::ermAM(stop) construct followed by kanamycin selection resulted in an increase of the fraction of erythromycin-resistant, edited cells to 99% (FIG. 26c). To determine if this increase is caused by the killing of non-edited cells, Applicants compared the kanamycin-resistant colony forming units (cfu) obtained after co-transformation of JEN53 cells with the CRISPR::ermAM(stop) or CRISPR:: \emptyset constructs.

[0265] Applicants counted 5.3 times less kanamycin-resistant colonies after transformation of the ermAM(stop) construct ($2.5 \times 10^4 / 4.7 \times 10^3$, FIG. 35a), a result that suggests that indeed targeting of a chromosomal locus by Cas9 leads to the killing of non-edited cells. Finally, because the introduction of dsDNA breaks in the bacterial chromosome is known to trigger repair mechanisms that increase the rate of recombination of the damaged DNA, Applicants investigated whether cleavage by Cas9 induces recombination of the editing template. Applicants counted 2.2 times more colonies after co-transformation with the CRISPR::erm(stop) construct than with the CRISPR:: \emptyset construct (FIG. 26d), indicating that there was a modest induction of recombination. Taken together, these results showed that co-selection of transformable cells, induction of recombination by Cas9-mediated cleavage and selection against non-edited cells, each contributed to the high efficiency of genome editing in *S. pneumoniae*.

[0266] As cleavage of the genome by Cas9 should kill non-edited cells, one would not expect to recover any cells that received the kanamycin resistance-containing Cas9 cassette but not the editing template. However, in the absence of the editing template Applicants recovered many kanamycin-resistant colonies after transformation of the CRISPR::ermAM(stop) construct (FIG. 35a). These cells that 'escape' CRISPR-induced death produced a background that determined a limit of the method. This background frequency may be calculated as the ratio of CRISPR::ermAM(stop)/CRISPR:: \emptyset cfu, 2.6×10^{-3} ($7.1 \times 10^1 / 2.7 \times 10^4$) in this experiment, meaning that if the recombination frequency of the editing template is less than this value, CRISPR selection may not efficiently recover the desired mutants above the background. To understand the origin of these cells, Applicants genotyped 8 background colonies and found that 7 contained deletions of the targeting spacer (FIG. 35b) and one harbored a presumably inactivating mutation in Cas9 (FIG. 35c).

[0267] Genome Editing with Cas9 in *E. coli*:

[0268] The activation of Cas9 targeting through the chromosomal integration of a CRISPR-Cas system is only possible in organisms that are highly recombinogenic. To develop a more general method that is applicable to other microbes, Applicants decided to perform genome editing in *E. coli* using a plasmid-based CRISPR-Cas system. Two plasmids were constructed: a pCas9 plasmid carrying the tracrRNA, Cas9 and a chloramphenicol resistance cassette (FIG. 36), and a pCRISPR kanamycin-resistant plasmid carrying the array of CRISPR spacers. To measure the

efficiency of editing independently of CRISPR selection, Applicants sought to introduce an A to C transversion in the rpsL gene that confers streptomycin resistance. Applicants constructed a pCRISPR::rpsL plasmid harboring a spacer that would guide Cas9 cleavage of the wild-type, but not the mutant rpsL allele (FIG. 27b). The pCas9 plasmid was first introduced into *E. coli* MG1655 and the resulting strain was co-transformed with the pCRISPR::rpsL plasmid and W542, an editing oligonucleotide containing the A to C mutation. streptomycin-resistant colonies after transformation of the pCRISPR::rpsL plasmid were only recovered, suggesting that Cas9 cleavage induces recombination of the oligonucleotide (FIG. 37). However, the number of streptomycin-resistant colonies was two orders of magnitude lower than the number of kanamycin-resistant colonies, which are presumably cells that escape cleavage by Cas9. Therefore, in these conditions, cleavage by Cas9 facilitated the introduction of the mutation, but with an efficiency that was not enough to select the mutant cells above the background of 'escapers'.

[0269] To improve the efficiency of genome editing in *E. coli*, Applicants applied their CRISPR system with recombineering, using Cas9-induced cell death to select for the desired mutations. The pCas9 plasmid was introduced into the recombineering strain HME63 (31), which contains the Gam, Exo and Beta functions of the \square -red phage. The resulting strain was co-transformed with the pCRISPR::rpsL plasmid (or a pCRISPR:: \emptyset control) and the W542 oligonucleotide (FIG. 27a). The recombineering efficiency was 5.3×10^{-5} , calculated as the fraction of total cells that become streptomycin-resistant when the control plasmid was used (FIG. 27c). In contrast, transformation with the pCRISPR::rpsL plasmid increased the percentage of mutant cells to $65 \pm 14\%$ (FIGS. 27c and 29f). Applicants observed that the number of cfu was reduced by about three orders of magnitude after transformation of the pCRISPR::rpsL plasmid than the control plasmid ($4.8 \times 10^5 / 5.3 \times 10^2$, FIG. 38a), suggesting that selection results from CRISPR-induced death of non-edited cells. To measure the rate at which Cas9 cleavage was inactivated, an important parameter of Applicants' method, Applicants transformed cells with either pCRISPR::rpsL or the control plasmid without the W542 editing oligonucleotide (FIG. 38a). This background of CRISPR 'escapers', measured as the ratio of pCRISPR::rpsL/pCRISPR:: \emptyset cfu, was 2.5×10^{-4} ($1.2 \times 10^2 / 4.8 \times 10^5$). Genotyping eight of these escapers revealed that in all cases there was a deletion of the targeting spacer (FIG. 38b). This background was higher than the recombineering efficiency of the rpsL mutation, 5.3×10^{-5} , which suggested that to obtain 65% of edited cells, Cas9 cleavage must induce oligonucleotide recombination. To confirm this, Applicants compared the number of kanamycin- and streptomycin-resistant cfu after transformation of pCRISPR::rpsL or pCRISPR:: \emptyset (FIG. 27d). As in the case for *S. pneumoniae*, Applicants observed a modest induction of recombination, about 6.7 fold ($2.0 \times 10^{-4} / 3.0 \times 10^{-5}$). Taken together, these results indicated that the CRISPR system provided a method for selecting mutations introduced by recombineering.

[0270] Applicants showed that CRISPR-Cas systems may be used for targeted genome editing in bacteria by the co-introduction of a targeting construct that killed wild-type cells and an editing template that both eliminated CRISPR cleavage and introduced the desired mutations. Different types of mutations (insertions, deletions or scar-less single-

nucleotide substitutions) may be generated. Multiple mutations may be introduced at the same time. The specificity and versatility of editing using the CRISPR system relied on several unique properties of the Cas9 endonuclease: (i) its target specificity may be programmed with a small RNA, without the need for enzyme engineering, (ii) target specificity was very high, determined by a 20 bp RNA-DNA interaction with low probability of non-target recognition, (iii) almost any sequence may be targeted, the only requirement being the presence of an adjacent NGG sequence, (iv) almost any mutation in the NGG sequence, as well as mutations in the seed sequence of the protospacer, eliminates targeting.

[0271] Applicants showed that genome engineering using the CRISPR system worked not only in highly recombinogenic bacteria such as *S. pneumoniae*, but also in *E. coli*. Results in *E. coli* suggested that the method may be applicable to other microorganisms for which plasmids may be introduced. In *E. coli*, the approach complements recombineering of mutagenic oligonucleotides. To use this methodology in microbes where recombineering is not a possibility, the host homologous recombination machinery may be used by providing the editing template on a plasmid. In addition, because accumulated evidence indicates that CRISPR-mediated cleavage of the chromosome leads to cell death in many bacteria and archaea, it is possible to envision the use of endogenous CRISPR-Cas systems for editing purposes.

[0272] In both *S. pneumoniae* and *E. coli*, Applicants observed that although editing was facilitated by a co-selection of transformable cells and a small induction of recombination at the target site by Cas9 cleavage, the mechanism that contributed the most to editing was the selection against non-edited cells. Therefore the major limitation of the method was the presence of a background of cells that escape CRISPR-induced cell death and lack the desired mutation. Applicants showed that these 'escapers' arose primarily through the deletion of the targeting spacer, presumably after the recombination of the repeat sequences that flank the targeting spacer. Future improvements may focus on the engineering of flanking sequences that can still support the biogenesis of functional crRNAs but that are sufficiently different from one another to eliminate recombination. Alternatively, the direct transformation of chimeric crRNAs may be explored. In the particular case of *E. coli*, the construction of the CRISPR-Cas system was not possible if this organism was also used as a cloning host. Applicants solved this issue by placing Cas9 and the tracrRNA on a different plasmid than the CRISPR array. The engineering of an inducible system may also circumvent this limitation.

[0273] Although new DNA synthesis technologies provide the ability to cost-effectively create any sequence with a high throughput, it remains a challenge to integrate synthetic DNA in living cells to create functional genomes. Recently, the co-selection MAGE strategy was shown to improve the mutation efficiency of recombineering by selecting a subpopulation of cells that has an increased probability to achieve recombination at or around a given locus. In this method, the introduction of selectable mutations is used to increase the chances of generating nearby non-selectable mutations. As opposed to the indirect selection provided by this strategy, the use of the CRISPR system makes it possible to directly select for the desired mutation and to recover it with a high efficiency. These technologies add to the toolbox of genetic engineers, and together with DNA

synthesis, they may substantially advance both the ability to decipher gene function and to manipulate organisms for biotechnological purposes. Two other studies also relate to CRISPR-assisted engineering of mammalian genomes. It is expected that these crRNA-directed genome editing technologies may be broadly useful in the basic and medical sciences.

[0274] Strains and culture conditions. *S. pneumoniae* strain R6 was provided by Dr. Alexander Tomasz. Strain crR6 was generated in a previous study. Liquid cultures of *S. pneumoniae* were grown in THYE medium (30 g/l Todd-Hewitt agar, 5 g/l yeast extract). Cells were plated on tryptic soy agar (TSA) supplemented with 5% defibrinated sheep blood. When appropriate, antibiotics were added as followings: kanamycin (400 µg/ml), chloramphenicol (5 g/ml), erythromycin (1 µg/ml) streptomycin (100 µg/ml) or spectinomycin (100 µg/ml). Measurements of P3-galactosidase activity were made using the Miller assay as previously described.

[0275] *E. coli* strains MG1655 and HME63 (derived from MG1655, Δ(argF-lac) U169λ cI857 Δcro-bioA galK tyr 145 UAG mutS<>amp) (31) were provided by Jeff Roberts and Donald Court, respectively. Liquid cultures of *E. coli* were grown in LB medium (Difco). When appropriate, antibiotics were added as followings: chloramphenicol (25 µg/ml), kanamycin (25 g/ml) and streptomycin (50 µg/ml).

[0276] *S. pneumoniae* Transformation.

[0277] Competent cells were prepared as described previously (23). For all genome editing transformations, cells were gently thawed on ice and resuspended in 10 volumes of M2 medium supplemented with 100 ng/ml of competence-stimulating peptide CSP1(40), and followed by addition of editing constructs (editing constructs were added to cells at a final concentration between 0.7 ng/l to 2.5 µg/ul). Cells were incubated 20 min at 37° C. before the addition of 2 µl of targeting constructs and then incubated 40 min at 37° C. Serial dilutions of cells were plated on the appropriate medium to determine the colony forming units (cfu) count.

[0278] *E. coli* Lambda-Red Recombineering.

[0279] Strain HME63 was used for all recombineering experiments. Recombineering cells were prepared and handled according to a previously published protocol (6). Briefly, a 2 ml overnight culture (LB medium) inoculated from a single colony obtained from a plate was grown at 30° C. The overnight culture was diluted 100-fold and grown at 30° C. with shaking (200 rpm) until the OD₆₀₀ is from 0.4-0.5 (approximately 3 hrs). For Lambda-red induction, the culture was transferred to a 42° C. water bath to shake at 200 rpm for 15 min. Immediately after induction, the culture was swirled in an ice-water slurry and chilled on ice for 5-10 min. Cells were then washed and aliquoted according to the protocol. For electro-transformation, 50 µl of cells were mixed with 1 mM of salt-free oligos (IDT) or 100-150 ng of plasmid DNA (prepared by QIAprep Spin Miniprep Kit, Qiagen). Cells were electroporated using 1 mm Gene Pulser cuvette (Bio-rad) at 1.8 kV and were immediately resuspended in 1 ml of room temperature LB medium. Cells were recovered at 30° C. for 1-2 hrs before being plated on LB agar with appropriate antibiotic resistance and incubated at 32° C. overnight.

[0280] Preparation of *S. pneumoniae* Genomic DNA.

[0281] For transformation purposes, *S. pneumoniae* genomic DNA was extracted using the Wizard Genomic DNA Purification Kit, following instructions provided by

the manufacturer (Promega). For genotyping purposes, 700 μ l of overnight *S. pneumoniae* cultures were pelleted, resuspended in 60 μ l of lysozyme solution (2 mg/ml) and incubated 30 min at 37° C. The genomic DNA was extracted using QIAprep Spin Miniprep Kit (Qiagen).

[0282] Strain Construction.

[0283] All primers used in this study are provided in Table G. To generate *S. pneumoniae* crR6M, an intermediate strain, LAM226, was made. In this strain the *aphA-3* gene (providing kanamycin resistance) adjacent to the CRISPR array of *S. pneumoniae* crR6 strain was replaced by a *cat* gene (providing chloramphenicol resistance). Briefly, crR6 genomic DNA was amplified using primers L448/L444 and L447/L481, respectively. The *cat* gene was amplified from plasmid pC194 using primers L445/L446. Each PCR product was gel-purified and all three were fused by SOEing PCR with primers L448/L481. The resulting PCR product was transformed into competent *S. pneumoniae* crR6 cells and chloramphenicol-resistant transformants were selected. To generate *S. pneumoniae* crR6M, *S. pneumoniae* crR6 genomic DNA was amplified by PCR using primers L409/L488 and L448/L481, respectively. Each PCR product was gel-purified and they were fused by SOEing PCR with primers L409/L481. The resulting PCR product was transformed into competent *S. pneumoniae* LAM226 cells and kanamycin-resistant transformants were selected.

[0284] To generate *S. pneumoniae* crR6Rc, *S. pneumoniae* crR6M genomic DNA was amplified by PCR using primers L430/W286, and *S. pneumoniae* LAM226 genomic DNA was amplified by PCR using primers W288/L481. Each PCR product was gel-purified and they were fused by SOEing PCR with primers L430/L481. The resulting PCR product was transformed into competent *S. pneumoniae* crR6M cells and chloramphenicol-resistant transformants were selected.

[0285] To generate *S. pneumoniae* crR6Rk, *S. pneumoniae* crR6M genomic DNA was amplified by PCR using primers L430/W286 and W287/L481, respectively. Each PCR product was gel-purified and they were fused by SOEing PCR with primers L430/L481. The resulting PCR product was transformed into competent *S. pneumoniae* crR6Rc cells and kanamycin-resistant transformants were selected.

[0286] To generate JEN37, *S. pneumoniae* crR6Rk genomic DNA was amplified by PCR using primers L430/W356 and W357/L481, respectively. Each PCR product was gel-purified and they were fused by SOEing PCR with primers L430/L481. The resulting PCR product was transformed into competent *S. pneumoniae* crR6Rc cells and kanamycin-resistant transformants were selected.

[0287] To generate JEN38, R6 genomic DNA was amplified using primers L422/L461 and L459/L426, respectively. The *ermAM* gene (specifying erythromycin resistance) was amplified from plasmid pFW15⁴³ using primers L457/L458. Each PCR product was gel-purified and all three were fused by SOEing PCR with primers L422/L426. The resulting PCR product was transformed into competent *S. pneumoniae* crR6Rc cells and erythromycin-resistant transformants were selected.

[0288] *S. pneumoniae* JEN53 was generated in two steps. First JEN43 was constructed as illustrated in FIG. 33. JEN53 was generated by transforming genomic DNA of JEN25 into competent JEN43 cells and selecting on both chloramphenicol and erythromycin.

[0289] To generate *S. pneumoniae* JEN62, *S. pneumoniae* crR6Rk genomic DNA was amplified by PCR using primers

W256/W365 and W366/L403, respectively. Each PCR product was purified and ligated by Gibson assembly. The assembly product was transformed into competent *S. pneumoniae* crR6Rc cells and kanamycin-resistant transformants were selected.

[0290] Plasmid construction. pDB97 was constructed through phosphorylation and annealing of oligonucleotides B296/B297, followed by ligation in pLZ12spec digested by EcoRI/BamHI. Applicants fully sequenced pLZ12spec and deposited its sequence in genebank (accession: KC 112384).

[0291] pDB98 was obtained after cloning the CRISPR leader sequence was cloned together with a repeat-spacer-repeat unit into pLZ12spec. This was achieved through amplification of crR6Rc DNA with primers B298/B320 and B299/B321, followed by SOEing PCR of both products and cloning in pLZ12spec with restriction sites BamHI/EcoRI. In this way the spacer sequence in pDB98 was engineered to contain two BsaI restriction sites in opposite directions that allow for the scar-less cloning of new spacers.

[0292] pDB99 to pDB108 were constructed by annealing of oligonucleotides B300/B301 (pDB99), B302/B303 (pDB100), B304/B305 (pDB101), B306/B307 (pDB102), B308/B309 (pDB103), B310/B311 (pDB104), B312/B313 (pDB105), B314/B315 (pDB106), B315/B317 (pDB107), B318/B319 (pDB108), followed by ligation in pDB98 cut by BsaI.

[0293] The pCas9 plasmid was constructed as follow. Essential CRISPR elements were amplified from *Streptococcus pyogenes* SF370 genomic DNA with flanking homology arms for Gibson Assembly. The tracrRNA and Cas9 were amplified with oligos HC008 and HC010. The leader and CRISPR sequences were amplified HC011/HC014 and HC015/HC009, so that two BsaI type IIS sites were introduced in between two direct repeats to facilitate easy insertion of spacers.

[0294] pCRISPR was constructed by subcloning the pCas9 CRISPR array in pZE21-MCS1 through amplification with oligos B298+B299 and restriction with EcoRI and BamHI. The *rpsL* targeting spacer was cloned by annealing of oligos B352+B353 and cloning in the BsaI cut pCRISPR giving pCRISPR::rpsL.

[0295] Generation of Targeting and Editing Constructs.

[0296] Targeting constructs used for genome editing were made by Gibson assembly of Left PCRs and Right PCRs (Table G). Editing constructs were made by SOEing PCR fusing PCR products A (PCR A), PCR products B (PCR B) and PCR products C (PCR C) when applicable (Table G). The CRISPR:: \emptyset and CRISPR::ermAM(stop) targeting constructs were generated by PCR amplification of JEN62 and crR6 genomic DNA respectively, with oligos L409 and L481.

[0297] Generation of Targets with Randomized PAM or Protospacer Sequences.

[0298] The 5 nucleotides following the spacer 1 target were randomized through amplification of R6^{8232.5} genomic DNA with primers W377/L426. This PCR product was then assembled with the *cat* gene and the *srtA* upstream region that were amplified from the same template with primers L422/W376. 80 ng of the assembled DNA was used to transform strains R6 and crR6. Samples for the randomized targets were prepared using the following primers: B280-B290/L426 to randomize bases 1-10 of the target and B269-B278/L426 to randomize bases 10-20. Primers L422/B268 and L422/B279 were used to amplify the *cat* gene and

srtA upstream region to be assembled with the first and last 10 PCR products respectively. The assembled constructs were pooled together and 30 ng was transformed in R6 and crR6. After transformation, cells were plated on chloramphenicol selection. For each sample more than 2×10^5 cells were pooled together in 1 ml of THYE and genomic DNA was extracted with the Promega Wizard kit. Primers B250/B251 were used to amplify the target region. PCR products were tagged and run on one Illumina MiSeq paired-end lane using 300 cycles.

[0299] Analysis of Deep Sequencing Data.

[0300] Randomized PAM: For the randomized PAM experiment 3,429,406 reads were obtained for crR6 and 3,253,998 for R6. It is expected that only half of them will correspond to the PAM-target while the other half will sequence the other end of the PCR product. 1,623,008 of the crR6 reads and 1,537,131 of the R6 reads carried an error-free target sequence. The occurrence of each possible PAM among these reads is shown in supplementary file. To estimate the functionality of a PAM, its relative proportion in the crR6 sample over the R6 sample was computed and is denoted r_{ijklm} where I, j, k, l, m are one of the 4 possible bases. The following statistical model was constructed:

$$\log(r_{ijklm}) = +b_2i + b_3j + b_4k + b_2b_3i_j + b_3b_4j_k + \epsilon_{ijklm},$$

where ϵ is the residual error, b_2 is the effect of the 2nd base of the PAM, b_3 of the third, b_4 of the fourth, b_2b_3 is the interaction between the second and third bases, b_3b_4 between the third and fourth bases. An analysis of variance was performed:

Anova table					
	Df	Sum Sq	Mean Sq	F value	Pr(>F)
b3	3	151.693	50.564	601.8450	<2.2e-16 ***
b2	3	90.521	30.174	359.1454	<2.2e-16 ***
b4	3	1.881	0.627	7.4623	6.070e-05 ***
b3:b2	9	228.940	25.438	302.7738	<2.2e-16 ***
b3:b4	9	3.010	0.334	3.9809	5.227e-05 ***
Residuals	996	83.680	0.084		

[0301] When added to this model, b_1 or b_5 do not appear to be significant and other interactions than the ones included can also be discarded. The model choice was made through successive comparisons of more or less complete models using the anova method in R. Tukey's honest significance test was used to determine if pairwise differences between effects are significant.

[0302] NGGNN patterns are significantly different from all other patterns and carry the strongest effect (see table below).

[0303] In order to show that positions 1, 4 or 5 do not affect the NGGNN pattern Applicants looked at these sequences only. Their effect appears to be normally distributed (see QQ plot in FIG. 71), and model comparisons using the anova method in R shows that the null model is the best one, i.e. there is no significant role of b_1 , b_4 and b_5 .

[0304] Model Comparison Using the Anova Method in R for the NGGNN Sequences

Model 1: ratio.log ~ 1						
Model 2: ratio.log ~ b1 + b4 + b5						
	Res. Df	RSS	Df	Sum of Sq	F	Pr(>F)
1	63	14.579				
2	54	11.295	9	3.2836	1.7443	0.1013

[0305] Partial Interference of NAGNN and NNGGN Patterns

[0306] NAGNN patterns are significantly different from all other patterns but carry a much smaller effect than NGGNN (see Tukey's honest significance test below).

[0307] Finally, NTGGN and NCGGN patterns are similar and show significantly more CRISPR interference than NTGHN and NCGHN patterns (where H is A, T or C), as shown by a bonferroni adjusted pairwise student-test.

[0308] Pairwise Comparisons of the Effect of b_4 on NYGNN Sequences Using t Tests with Pooled SD

Data: b4			
	A	C	G
C	1.00	—	—
G	9.2e-05	2.4e-06	—
T	0.31	1.00	1.2e-08

[0309] Taken together, these results allow concluding that NNGGN patterns in general produce either a complete interference in the case of NGGNN, or a partial interference in the case of NAGNN, NTGGN or NCGGN.

[0310] Tukey multiple comparisons of means: 95% family-wise confidence level

	diff	lwr	upr	p adj
Sb2:b3				
G:G-A:A	-2.76475	-2.94075	-2.58875	<1E-07
G:G-C:A	-2.79911	-2.97511	-2.62311	<1E-07
G:G-T:A	-2.7809	-2.9569	-2.6049	<1E-07
G:G-A:C	-2.81643	-2.99244	-2.64043	<1E-07
G:G-C:C	-2.77903	-2.95504	-2.60303	<1E-07
G:G-G:C	-2.64867	-2.82468	-2.47267	<1E-07
G:G-T:C	-2.79718	-2.97319	-2.62118	<1E-07
G:G-A:G	-2.67068	-2.84668	-2.49468	<1E-07
G:G-C:G	-2.73525	-2.91125	-2.55925	<1E-07
G:G-T:G	-2.7976	-2.62159	-2.9736	<1E-07
G:G-A:T	-2.76727	-2.59127	-2.94328	<1E-07
G:G-C:T	-2.84114	-2.66513	-3.01714	<1E-07
G:G-G:T	-2.76409	-2.58809	-2.94009	<1E-07
G:G-T:T	-2.76781	-2.59181	-2.94381	<1E-07
G:G-G:A	-2.13964	-2.31565	-1.96364	<1E-07
G:A-A:A	-0.62511	-0.80111	-0.4491	<1E-07
G:A-C:A	-0.65947	-0.83547	-0.48346	<1E-07
G:A-T:A	-0.64126	-0.46525	-0.81726	<1E-07
G:A-A:C	-0.67679	-0.50078	-0.85279	<1E-07
G:A-C:C	-0.63939	-0.46339	-0.81539	<1E-07
G:A-G:C	-0.50903	-0.33303	-0.68503	<1E-07
G:A-T:C	-0.65754	-0.48154	-0.83354	<1E-07
G:A-A:G	-0.53104	-0.35503	-0.70704	<1E-07
G:A-C:G	-0.59561	-0.4196	-0.77161	<1E-07
G:A-T:G	-0.65795	-0.48195	-0.83396	<1E-07
G:A-A:T	-0.62763	-0.45163	-0.80363	<1E-07

-continued

	diff	lwr	upr	p adj
G:A-C:T	-0.70149	-0.52549	-0.8775	<1E-07
G:A-G:T	-0.62445	-0.44844	-0.80045	<1E-07
G:A-T:T	-0.62817	-0.45216	-0.80417	<1E-07
		\$b3:b4		
G:G-G:A	-0.33532	-0.51133	-0.15932	<1E-07
G:G-G:C	-0.18118	-0.35719	-0.00518	0.036087
G:G-G:T	-0.31626	-0.14026	-0.49226	<1E-07

[0311] Randomized Target

[0312] For the randomized target experiment 540,726 reads were obtained for crR6 and 753,570 for R6. As before, only half of the reads are expected to sequence the interest-

ing end of the PCR product. After filtering for reads that carry a target that is error-free or with a single point mutation, 217,656 and 353,141 reads remained for crR6 and R6 respectively. The relative proportion of each mutant in the crR6 sample over the R6 sample was computed (FIG. 24c). All mutations outside of the seed sequence (13-20 bases away from the PAM) show full interference. Those sequences were used as a reference to determine if other mutations inside the seed sequence can be said to significantly disrupt interference. A normal distribution was fitted to these sequences using the fitdistr function of the MASS R package. The 0.99 quantile of the fitted distribution is shown as a dotted line in FIG. 24c. FIG. 72 shows a histogram of the data density with fitted normal distribution (black line) and 0.99 quantile (dotted line).

TABLE F

Relative abundance of PAM sequences in the crR6/R6 samples averaged over bases 1 and 5.											
		3rd position									
		A	C	G	T						
2nd position	A	AAA	1.04	ACA	1.12	AGA	0.73	ATA	1.10	A	4th position
		AAC	1.07	ACC	1.04	AGC	0.64	ATC	0.97	C	
		AAG	1.00	ACG	1.09	AGG	0.61	ATG	1.07	G	
		AAT	0.98	ACT	1.02	AGT	0.65	ATT	1.01	T	
	C	CAA	1.05	CCA	1.05	CGA	0.99	CTA	1.07	A	
		CAC	1.04	CCC	1.02	CGC	1.08	CTC	1.04	C	
		CAG	1.08	CCG	1.08	CGG	0.81	CTG	1.05	G	
		CAT	1.13	CCT	1.05	CGT	1.07	CTT	1.08	T	
	G	GAA	0.97	GCA	1.05	GGA	0.08	GTA	0.99	A	
		GAC	0.92	GCC	1.00	GGC	0.05	GTC	1.15	C	
		GAG	0.96	GCG	0.98	GGG	0.07	GTG	0.98	G	
		GAT	0.98	GCT	0.99	GGT	0.06	GTT	1.05	T	
	T	TAA	1.08	TCA	1.16	TGA	1.05	TTA	1.14	A	
		TAC	1.00	TCC	1.08	TGC	1.08	TTC	1.05	C	
		TAG	1.02	TCG	1.11	TGG	0.77	TTG	1.01	G	
		TAT	1.01	TCT	1.12	TGT	1.21	TTT	1.02	T	

TABLE G

Primers used in this study (SEQ ID NOS 68-183, respectively, in order of appearance).	
Primer	Sequence 5'-3'
B217	TCCTAGCAGGATTTCTGATATTACTGTACGTTTTAGAGCTATGTGTTTTGA
B218	GTGACAGTAATATCAGAAATCTGCTAGGAGTTTTGGGACCATTCAAACAGC
B229	GGGTTTCAAGTCTTTGTAGCAAGAG
B230	GCCAATGAACGGGAACCCCTGGTC
B250	NNNGACGAGGCAATGGCTGAAATC
B251	NNNNTTATTTGGCTCATATTTGCTG
B255	CTTTACACCAATCGCTGCAACAGAC
B256	CAAATTTCTAGTCTTCTTTGCCTTTCCCATAAAAACCTCCTTA
B257	AGGGTTTTATGGGAAAGGCAAGAAGACTAGAAATTTTGATACC
B258	CTTACGGTGCATAAAGTCAATTTCC
B269	TGGCTCGATTTTCCAGCCATTGC
B270	CTTTGACGAGGCAATGGCTGAAATCGAGCCAANAAGCGCAAG

TABLE G-continued

Primers used in this study (SEQ ID NOS 68-183, respectively, in order of appearance).	
Primer	Sequence 5'-3'
B271	CTTTGACGAGGCAATGGCTGAAATCGAGCCAAAANAGCGCAAG
B272	CTTTGACGAGGCAATGGCTGAAATCGAGCCAAAANAGCGCAAG
B273	CTTTGACGAGGCAATGGCTGAAATCGAGCCAAAANAGCGCAAG
B274	CTTTGACGAGGCAATGGCTGAAATCGAGCCAAAANAGCGCAAG
B275	CTTTGACGAGGCAATGGCTGAAATCGAGCCAAAANAGCGCAAG
B276	CTTTGACGAGGCAATGGCTGAAATCGAGCCAAAANAGCGCAAG
B277	CTTTGACGAGGCAATGGCTGAAATCGAGCCAAAANAGCGCAAG
B278	CTTTGACGAGGCAATGGCTGAAATCGAGCCAAAANAGCGCAAG
B279	GCGCTTTTTGGCTCGATTTGAG
B280	CAATGGCTGAAATCGAGCCAAAANAGCGCAAGAAATC
B281	CAATGGCTGAAATCGAGCCAAAANAGCGCAAGAAATC
B282	CAATGGCTGAAATCGAGCCAAAANAGCGCAAGAAATC
B283	CAATGGCTGAAATCGAGCCAAAANAGCGCAAGAAATC
B284	CAATGGCTGAAATCGAGCCAAAANAGCGCAAGAAATC
B285	CAATGGCTGAAATCGAGCCAAAANAGCGCAAGAAATC
B286	CAATGGCTGAAATCGAGCCAAAANAGCGCAAGAAATC
B287	CAATGGCTGAAATCGAGCCAAAANAGCGCAAGAAATC
B288	CAATGGCTGAAATCGAGCCAAAANAGCGCAAGAAATC
B289	CAATGGCTGAAATCGAGCCAAAANAGCGCAAGAAATC
B290	CAATGGCTGAAATCGAGCCAAAANAGCGCAAGAAATC
B296	gatccTCCATCCGTACAACCCACACCCCTGg
B297	aattcCAGGGTTGTGGTTGTACGGATGGAg
B298	CATGGATCCTATTTCTTAATAACTAAAAATATGG
B299	CATGAATCAACTCAACAAGTCTCAGTGTGCTG
B300	AAACATTTTTCTCCATTTAGGAAAAGGATGCTG
B301	AAAACAGCATCCTTTTTCTAAATGGAGAAAAAT
B302	AAACCTTAAATCAGTCACAAATAGCAGCAAATG
B303	AAAACAATTTGCTGCTATTTGTGACTGATTTAAG
B304	AAACTTTTCATCATAAGCAATCTGCTTTATTTG
B305	AAAACAATAAAGCAGATTGGTCGTATGATGAAA
B306	AAACTCGTCCAGAAGTTATCGTAAAAGAAATCGAG
B307	AAAACCTGATTTCTTTTACGATAACTTCTGGACGA
B308	AAACAATCTCTCAAGGTTTCTTAAAAATCTCTG
B309	AAAACAGAGATTTTAAAGGAAACCTTGAGAGATT
B310	AAACGCCATCGTCAGGAAGAAGCTATGCTTGAGTG
B311	AAAACACTCAAGCATAGCTTCTTCTGACGATGGC

TABLE G-continued

Primers used in this study (SEQ ID NOS 68-183, respectively, in order of appearance).	
Primer	Sequence 5'-3'
B312	AAACATCTCTATACTTATTGAAATTTCTTTGTATG
B313	AAAACATACAAAGAAATTTCAATAAGTATAGAGAT
B314	AAACTAGCTGTGATAGTCCGCAAACCAGCCTTCG
B315	AAAACGAAGGCTGGTTTTGCGGACTATCACAGCTA
B316	AAACATCGGAAGGTCGAGCAAGTAATTATCTTTTG
B317	AAAACAAAGATAATTACTTGCTCGACCTTCCGAT
B318	AAACAAGATGGTATCGCAAATAAGTGACAATAAG
B319	AAAACCTATTGTCACTTACTTTGCGATACCATCTT
B320	GAGACCTTTGAGCTTCCGAGACTGGTCTCAGTTTTGGGACCATTCAAACAG
B321	TGAGACCAGTCTCGGAAGCTCAAAGGTCTCGTTTTAGAGCTATGCTGTTTTG
B352	aaacTACTTTACGCAGCGCGGAGTTCGGTTTTTTg
B353	aaaacAAAAACCGAACTCCGCGCTGCGTAAAGTA
HC008_SP	ATGCCGGTACTGCCGGGCCTCTGCGGGATTACGAAATCATCCTG
HC009_SP	GTGACTGGCGATGCTGTCCGGAATGGACGATCACACTACTCTTCTT
HC010_SP	TTAAGAAATAATCTTCATCTAAAATATACTTCAGTCACCTCCTAGCTGAC
HC011_SP	ATTGATTGTAGTCAGCTAGGAGGTGACTGAAGTATATTTTAGATGAAG
HC014_SP	GAGACCTTTGAGCTTCCGAGACTGGTCTCAGTTTTGGGACCATTCAAACAGCATAGCTCTAAAACCTCGTAGACTA TTTTTGTC
HC015_SP	GAGACCAGTCTCGGAAGCTCAAAGGTCTCGTTTTAGAGCTATGCTGTTTTGAATGGTCCCAAACTTCAGCACACTG AGACTTG
L403	AGTCATCCCAGCAACAAATGG
L409	CGTGGTAAATCGGATAACGTTCCAAGTGAAG
L422	Tgctcttcttcacaaacaaggg
L426	AAGCCAAAGTTTGGCACCACC
L430	GTAGCTTATTCAGTCCTAGTGG
L444	CGTTTGTGAACTAATGGGTGCAAATTACGAATCTTCTCCTGACG
L445	CGTCAGGAGAAGATTCGTAATTTGCACCATTAGTTCACCAAACG
L446	GATATTATGGAGCCTATTTTTGTGGGTTTTTAGGCATAAACTATATG
L447	CATATAGTTTTATGCCTAAAACCCACAAAAATAGGCTCCATAATATC
L448	ATTATTTCTTAATAACTAAAAATATGG
L457	CGTgtacaattgctagegtaeggc
L458	GCACCGGTGATCACTAGTCCTAGG
L459	cctaggactagtgatcaccggtGCAAATATGAGCCAAATAAATATAT
L461	GCCGTACGCTAGCAATTGTACACGTTTTGTTGAACTAATGGGTGC
L481	TTCAAATTTTCCCATTTGATTCCTC
L488	CCATATTTTTAGTTATTAAGAAATAATACCAGCCATCAGTCACCTCC

TABLE G-continued

Primers used in this study (SEQ ID NOS 68-183, respectively, in order of appearance).	
Primer	Sequence 5'-3'
W256	AGACGATTC AATAGACAATAAGG
W286	GTTTTGGGACCATTCAAACAGCATAGCTCTAAAACCTCGTAGAC
W287	GCTATGCTGTTTTGAATGGTCCCAAACcattattttaacacacgaggtg
W288	GCTATGCTGTTTTGAATGGTCCCAAACGCACCCATTAGTTCAACAAACG
W326	AATTCTTTTCTTCATCATCGGTC
W327	AAGAAAG AATGAAGATTGTTTCATG
W341	GGTACTAATCAAATAGTGAGGAGG
W354	GTTTTTCAAATCTGCGGTTGCG
W355	AAAAATTGAAAAATGGTGGAAACAC
W356	ATTTTCGTAACGGTATCGGTTTCTTTTAAAGTTTTGGGACCATTCAAACAGC
W357	TTTAAAGAAACCGATACCGTTTACGAAATGTTTTAGAGCTATGCTGTTTTGA
W365	AAACGGTATCGGTTTCTTTTAAATCAATTGTTTTGGGACCATTCAAACAGC
W366	AATTGAATTTAAAAGAAACCGATACCGTTTGTGTTTTAGAGCTATGCTGTTTTGA
W370	GTTCTTAAACCAAACGGTATCGGTTTCTTTTAAATTC
W371	GAAACCGATACCGTTTGGTTTAAAGGAACAGGTAAGGGCATTTAAC
W376	CGATTT CAGCCATTGCCTCGTC
W377	GCCTTTGACGAGGCAATGGCTGAAATCGNNNNAAAAAGCGCAAGAAGAAATCAAC
W391	TCCGTACAACCCACAACCCTGCTAGTGAGCGTTTTGGGACCATTCAAACAGC
W392	GCTCACTAGCAGGGTTGTGGGTTGTACGGAGTTTTAGAGCTATGCTGTTTTGA
W393	TTGTTGCCACTCTTCCTTCTTC
W397	CAGGGTTGTGGGTTGTTGCGATGGAGTTAACTCCCATCTCC
W398	GGGAGTTAACTCCATCGCAACAACCCACAACCCTGCTAGTG
W403	GTGGTATCTATCGTGATGTGAC
W404	TTACCGAAACGGAATTTATCTGC
W405	AAAGCTAGAGTTCCGCAATTGG
W431	GTGGGTTGTACGGATTGAGTTAACTCCCATCTCCTTC
W432	GATGGGAGTTAACTCAATCCGTACAACCCACAACCCTG
W433	GCTTCACCTATTGCAGCACCAATTGACCACATGAAGATAG
W434	GTGGTCAATTGGTGCTGCAATAGGTGAAGCTAATGGTGATG
W463	CTGATTTGTATTAATTTTGAGACATTATGCTTCACCTTC
W464	GCATAATGTCTCAAATTAATACAAATCAGTGAATCATG
W465	GTTTTGGGACCATTCAAACAGCATAGCTCTAAAACGTGACAGTAATATCAG
W466	GTTTTAGAGCTATGCTGTTTTGAATGGTCCCAAACGCTCACTAGCAGGGTTG
W542	ATACTTTACGCAGCGCGGAGTTCGGTTTTgTAGGAGTGGTAGTATATACAGGTACAT

TABLE H

Design of targeting and editing constructs used in this study (SEQ ID NOS 184, 184, 184, 185, and 186, respectively, in order of appearance).							
Edition	Targeting Constructs Template DNA	Left PCR	Right PCR	Spacer sequence			PAM
bgaA R>A	crR6Rk	W256/W391	W392/L403	GCTCACTAGCAGGGTTGTGGTTGTACGGA			TGG
bgaA NE>AA	crR6Rk	W256/W391	W392/L403	GCTCACTAGCAGGGTTGTGGTTGTACGGA			TGG
AbgaA	crR6Rk	W256/W391	W392/L403	GCTCACTAGCAGGGTTGTGGTTGTACGGA			TGG
AsrtA	crR6Rc	W256/B218	B217/L403	TCCTAGCAGGATTTCTGATATTACTGTCAC			TGG
ermB Stop	crR6Rk	W256/W356	W357/L403	TTTAAAAGAAACCGATACCGTTTACGAAAT			TGG
AsrtA AbgaA	JEN51 (for Left PCR) and JEN52 (for Right PCR)	W256/W465	W466/W403	same as the ones used for AsrtA and AbgaA			TGG

Edition	Editing Constructs Template DNA	PCR A	PCR B	PCR C	SOEing PCR	Name of resulting strains	Primers used to verify edited genotype
bgaA R>A	R6	W403/W397	W398/W404	N/A	W403/W404	JEN56	W403/W404
bgaA NE>AA	R6	W403/W431	W432/W433	W434/W404	W403/W404	JEN60	W403/W404
AbgaA	R6	B255/B256	B257/B258	N/A	B255/B258	JEN52	W393/W405
AsrtA	R6	B230/W463	W464/B229	N/A	B230/B229	JEN51	W422/W426
ermB Stop	JEN38	L422/W370	W371/L426	N/A	L422/L426	JEN43	L457/L458
AsrtA AbgaA	same as the ones used for AsrtA and AbgaA					JEN64	same as the ones used for AsrtA and AbgaA

Example 6: Optimization of the Guide RNA for *Streptococcus pyogenes* Cas9 (Referred to as SpCas9)

[0313] Applicants mutated the tracrRNA and direct repeat sequences, or mutated the chimeric guide RNA to enhance the RNAs in cells.

[0314] The optimization is based on the observation that there were stretches of thymines (Ts) in the tracrRNA and guide RNA, which might lead to early transcription termination by the pol 3 promoter. Therefore Applicants generated the following optimized sequences. Optimized tracrRNA and corresponding optimized direct repeat are presented in pairs.

[0315] Optimized tracrRNA 1 (mutation underlined):

(SEQ ID NO: 187)
 GGAACCATTCAAACACAGCATAGCAAGTTAAATAAAGGCTAGTCCGTTATC
 AACTTGAAAAAGTGGCACCGAGTCGGTGCTTTTT

[0316] Optimized direct repeat 1 (mutation underlined):

(SEQ ID NO: 188)
 GTTaTAGAGCTATGCTGTTaTGAATGGTCCCAAAC

[0317] Optimized tracrRNA 2 (mutation underlined):

(SEQ ID NO: 189)
 GGAACCATTCAAACACAGCATAGCAAGTTAAAATAAAGGCTAGTCCGTTATC
 AACTTGAAAAAGTGGCACCGAGTCGGTGCTTTTT

[0318] Optimized direct repeat 2 (mutation underlined):

(SEQ ID NO: 190)
 GTaTTAGAGCTATGCTGTaTTGAATGGTCCCAAAC

[0319] Applicants also optimized the chimeric guideRNA for optimal activity in eukaryotic cells.

[0320] Original guide RNA:

(SEQ ID NO: 191)
 NNNNNNNNNNNNNNNNNNNNGTTTTAGAGCTAGAAATAGCAAGTTAAAAAT
 AAGGCTAGTCCGTTATCAACTTGAAAAAGTGGCACCGAGTCGGTGCTTTTT
 TTT

[0321] Optimized chimeric guide RNA sequence 1:

(SEQ ID NO: 192)
 NNNNNNNNNNNNNNNNNNNNGTATTAGAGCTAGAAATAGCAAGTTAATAT
 AAGGCTAGTCCGTTATCAACTTGAAAAAGTGGCACCGAGTCGGTGCTTTT
 TTT

[0322] Optimized chimeric guide RNA sequence 2:

(SEQ ID NO: 193)
 NNNNNNNNNNNNNNNNNNNNGTTTTAGAGCTATGCTGTTTTGGAACAAA
 ACAGCATAGCAAGTTAAAATAAGGCTAGTCCGTTATCAACTTGAAAAAGT
 GGCACCGAGTCGGTGCTTTTTTTT

[0323] Optimized chimeric guide RNA sequence 3:

(SEQ ID NO: 194)
 NNNNNNNNNNNNNNNNNNNNGTATTAGAGCTATGCTGTTTGGAAACAAT
 ACAGCATAGCAAGTTAATAAAGGCTAGTCCGTTATCAACTTGAAAAAGT
 GGCACCGAGTCGGTGCTTTTTTTT

[0324] Applicants showed that optimized chimeric guide RNA works better as indicated in FIG. 3. The experiment was conducted by co-transfecting 293FT cells with Cas9 and a U6-guide RNA DNA cassette to express one of the four RNA forms shown above. The target of the guide RNA is the same target site in the human Emx1 locus: “GTCACCTC-CAATGACTAGGG (SEQ ID NO: 195)”

Example 7: Optimization of *Streptococcus thermophilus* LMD-9 CRISPR1 Cas9 (Referred to as StlCas9)

[0325] Applicants designed guide chimeric RNAs as shown in FIG. 4.

[0326] The StlCas9 guide RNAs can undergo the same type of optimization as for SpCas9 guide RNAs, by breaking the stretches of poly thymines (Ts)

Example 8: Cas9 Diversity and Mutations

[0327] The CRISPR-Cas system is an adaptive immune mechanism against invading exogenous DNA employed by diverse species across bacteria and archaea. The type II CRISPR-Cas9 system consists of a set of genes encoding proteins responsible for the “acquisition” of foreign DNA into the CRISPR locus, as well as a set of genes encoding the “execution” of the DNA cleavage mechanism; these include the DNA nuclease (Cas9), a non-coding transactivating cr-RNA (tracrRNA), and an array of foreign DNA-derived spacers flanked by direct repeats (crRNAs). Upon maturation by Cas9, the tracrRNA and crRNA duplex guide the Cas9 nuclease to a target DNA sequence specified by the spacer guide sequences, and mediates double-stranded breaks in the DNA near a short sequence motif in the target DNA that is required for cleavage and specific to each CRISPR-Cas system. The type II CRISPR-Cas systems are found throughout the bacterial kingdom and highly diverse in Cas9 protein sequence and size, tracrRNA and crRNA direct repeat sequence, genome organization of these ele-

ments, and the motif requirement for target cleavage. One species may have multiple distinct CRISPR-Cas systems.

[0328] Applicants evaluated 207 putative Cas9s from bacterial species identified based on sequence homology to known Cas9s and structures orthologous to known subdomains, including the HNH endonuclease domain and the RuvC endonuclease domains [information from the Eugene Koonin and Kira Makarova]. Phylogenetic analysis based on the protein sequence conservation of this set revealed five families of Cas9s, including three groups of large Cas9s (~1400 amino acids) and two of small Cas9s (~1100 amino acids) (FIGS. 39 and 40A-F).

[0329] In this example, Applicants show that the following mutations can convert SpCas9 into a nicking enzyme: D10A, E762A, H840A, N854A, N863A, D986A.

[0330] Applicants provide sequences showing where the mutation points are located within the SpCas9 gene (FIG. 41). Applicants also show that the nickases are still able to mediate homologous recombination (Assay indicated in FIG. 2). Furthermore, Applicants show that SpCas9 with these mutations (individually) do not induce double strand break (FIG. 47).

Example 9: Supplement to DNA Targeting Specificity of the RNA-Guided Cas9 Nuclease

[0331] Cell Culture and Transfection

[0332] Human embryonic kidney (HEK) cell line 293FT (Life Technologies) was maintained in Dulbecco’s modified Eagle’s Medium (DMEM) supplemented with 10% fetal bovine serum (HyClone), 2 mM GlutaMAX (Life Technologies), 100 U/mL penicillin, and 100 g/mL streptomycin at 37° C. with 5% CO₂ incubation.

[0333] 293FT cells were seeded either onto 6-well plates, 24-well plates, or 96-well plates (Corning) 24 hours prior to transfection. Cells were transfected using Lipofectamine 2000 (Life Technologies) at 80-90% confluence following the manufacturer’s recommended protocol. For each well of a 6-well plate, a total of 1 ug of Cas9+sgRNA plasmid was used. For each well of a 24-well plate, a total of 500 ng Cas9+sgRNA plasmid was used unless otherwise indicated. For each well of a 96-well plate, 65 ng of Cas9 plasmid was used at a 1:1 molar ratio to the U6-sgRNA PCR product.

[0334] Human embryonic stem cell line HUES9 (Harvard Stem Cell Institute core) was maintained in feeder-free conditions on GelTrex (Life Technologies) in mTesR medium (Stemcell Technologies) supplemented with 100 ug/ml Normocin (InvivoGen). HUES9 cells were transfected with Amaxa P3 Primary Cell 4-D Nucleofector Kit (Lonza) following the manufacturer’s protocol.

[0335] SURVEYOR Nuclease Assay for Genome Modification

[0336] FT cells were transfected with plasmid DNA as described above. Cells were incubated at 37° C. for 72 hours post-transfection prior to genomic DNA extraction. Genomic DNA was extracted using the QuickExtract DNA Extraction Solution (Epicentre) following the manufacturer’s protocol. Briefly, pelleted cells were resuspended in QuickExtract solution and incubated at 65° C. for 15 minutes and 98° C. for 10 minutes.

[0337] The genomic region flanking the CRISPR target site for each gene was PCR amplified (primers listed in Tables J and K), and products were purified using QiaQuick Spin Column (Qiagen) following the manufacturer’s protocol. 400 ng total of the purified PCR products were mixed

with 2 μ l 10 \times Taq DNA Polymerase PCR buffer (Enzymatics) and ultrapure water to a final volume of 20 μ l, and subjected to a re-annealing process to enable heteroduplex formation: 95 $^{\circ}$ C. for 10 min, 95 $^{\circ}$ C. to 85 $^{\circ}$ C. ramping at -2° C./s, 85 $^{\circ}$ C. to 25 $^{\circ}$ C. at -0.25° C./s, and 25 $^{\circ}$ C. hold for 1 minute. After re-annealing, products were treated with SURVEYOR nuclease and SURVEYOR enhancer S (Transgenomics) following the manufacturer's recommended protocol, and analyzed on 4-20% Novex TBE poly-acrylamide gels (Life Technologies). Gels were stained with SYBR Gold DNA stain (Life Technologies) for 30 minutes and imaged with a Gel Doc gel imaging system (Bio-rad). Quantification was based on relative band intensities.

[0338] Northern Blot Analysis of tracrRNA Expression in Human Cells

[0339] Northern blots were performed as previously described. Briefly, RNAs were heated to 95 $^{\circ}$ C. for 5 min before loading on 8% denaturing polyacrylamide gels (SequaGel, National Diagnostics). Afterwards, RNA was transferred to a pre-hybridized Hybond N+ membrane (GE Healthcare) and crosslinked with Stratagene UV Crosslinker (Stratagene). Probes were labeled with [γ -³²P] ATP (Perkin Elmer) with T4 polynucleotide kinase (New England Biolabs). After washing, membrane was exposed to phosphor screen for one hour and scanned with phosphorimager (Typhoon).

[0340] Bisulfite Sequencing to Assess DNA Methylation Status

[0341] HEK 293FT cells were transfected with Cas9 as described above. Genomic DNA was isolated with the DNeasy Blood & Tissue Kit (Qiagen) and bisulfite converted with EZ DNA Methylation-Lightning Kit (Zymo Research). Bisulfite PCR was conducted using KAPA2G Robust HotStart DNA Polymerase (KAPA Biosystems) with primers designed using the Bisulfite Primer Seeker (Zymo Research, Tables J and K). Resulting PCR amplicons were gel-purified, digested with EcoRI and HindIII, and ligated into a pUC19 backbone prior to transformation. Individual clones were then Sanger sequenced to assess DNA methylation status.

[0342] In Vitro Transcription and Cleavage Assay

[0343] HEK 293FT cells were transfected with Cas9 as described above. Whole cell lysates were then prepared with a lysis buffer (20 mM HEPES, 100 mM KCl, 5 mM MgCl₂, 1 mM DTT, 5% glycerol, 0.1% Triton X-100) supplemented with Protease Inhibitor Cocktail (Roche). T7-driven sgRNA was in vitro transcribed using custom oligos (Example 10) and HiScribe T7 In Vitro Transcription Kit (NEB), following the manufacturer's recommended protocol. To prepare methylated target sites, pUC19 plasmid was methylated by M.SssI and then linearized by NheI. The in vitro cleavage assay was performed as follows: for a 20 μ l cleavage reaction, 10 μ l of cell lysate with incubated with 2 μ l cleavage buffer (100 mM HEPES, 500 mM KCl, 25 mM MgCl₂, 5 mM DTT, 25% glycerol), the in vitro transcribed RNA, and 300 ng pUC19 plasmid DNA.

[0344] Deep Sequencing to Assess Targeting Specificity

[0345] HEK 293FT cells plated in 96-well plates were transfected with Cas9 plasmid DNA and single guide RNA (sgRNA) PCR cassette 72 hours prior to genomic DNA extraction (FIG. 72). The genomic region flanking the CRISPR target site for each gene was amplified (FIG. 74, FIG. 80, (Example 10) by a fusion PCR method to attach the Illumina P5 adapters as well as unique sample-specific

barcodes to the target amplicons (schematic described in FIG. 73). PCR products were purified using EconoSpin 96-well Filter Plates (Epoch Life Sciences) following the manufacturer's recommended protocol.

[0346] Barcoded and purified DNA samples were quantified by Quant-iT PicoGreen dsDNA Assay Kit or Qubit 2.0 Fluorometer (Life Technologies) and pooled in an equimolar ratio. Sequencing libraries were then deep sequenced with the Illumina MiSeq Personal Sequencer (Life Technologies).

[0347] Sequencing Data Analysis and Indel Detection

[0348] MiSeq reads were filtered by requiring an average Phred quality (Q score) of at least 23, as well as perfect sequence matches to barcodes and amplicon forward primers. Reads from on- and off-target loci were analyzed by first performing Smith-Waterman alignments against amplicon sequences that included 50 nucleotides upstream and downstream of the target site (a total of 120 bp). Alignments, meanwhile, were analyzed for indels from 5 nucleotides upstream to 5 nucleotides downstream of the target site (a total of 30 bp). Analyzed target regions were discarded if part of their alignment fell outside the MiSeq read itself, or if matched base-pairs comprised less than 85% of their total length.

[0349] Negative controls for each sample provided a gauge for the inclusion or exclusion of indels as putative cutting events. For each sample, an indel was counted only if its quality score exceeded $\mu - \sigma$, where μ was the mean quality-score of the negative control corresponding to that sample and σ was the standard deviation of same. This yielded whole target-region indel rates for both negative controls and their corresponding samples. Using the negative control's per-target-region-per-read error rate, q , the sample's observed indel count n , and its read-count R , a maximum-likelihood estimate for the fraction of reads having target-regions with true-indels, p , was derived by applying a binomial error model, as follows.

[0350] Letting the (unknown) number of reads in a sample having target regions incorrectly counted as having at least 1 indel be E , we can write (without making any assumptions about the number of true indels)

$$Prob(E | p) = \binom{R(1-p)}{E} q^E (1-q)^{R(1-p)-E}$$

[0351] since $R(1-p)$ is the number of reads having target-regions with no true indels. Meanwhile, because the number of reads observed to have indels is n , $n = E + Rp$, in other words the number of reads having target-regions with errors but no true indels plus the number of reads whose target-regions correctly have indels. e can then re-write the above

$$Prob(E | p) = Prob(n = E + Rp | p) = \binom{R(1-p)}{n - Rp} q^{n - Rp} (1 - q)^{R - n} \textcircled{2}$$

$\textcircled{2}$ indicates text missing or illegible when filed

[0352] Taking all values of the frequency of target-regions with true-indels P to be equally probable a priori, $Prob(n|p) \propto Prob(p|n)$. The maximum-likelihood estimate (MLE) for

the frequency of target regions with true-indels was therefore set as the value of P that maximized Prob(n|p). This was evaluated numerically.

[0353] In order to place error bounds on the true-indel read frequencies in the sequencing libraries themselves, Wilson score intervals (2) were calculated for each sample, given the MLE-estimate for true-indel target-regions, Pp, and the number of reads R. Explicitly, the lower bound l and upper bound u were calculated as

$$l = \left(Rp + \frac{z^2}{2} - z\sqrt{Rp(1-p) + \frac{z^2}{4}} \right) / (R + z^2)$$

$$u = \left(Rp + \frac{z^2}{2} + z\sqrt{Rp(1-p) + \frac{z^2}{4}} \right) / (R + z^2)$$

② indicates text missing or illegible when filed

[0354] where z, the standard score for the confidence required in normal distribution of variance 1, was set to 1.96, meaning a confidence of 95%. The maximum upper bounds and minimum lower bounds for each biological replicate are listed in FIGS. 80-83.

[0355] qRT-PCR Analysis of Relative Cas9 and sgRNA Expression

[0356] FT cells plated in 24-well plates were transfected as described above. 72 hours post-transfection, total RNA was harvested with miRNeasy Micro Kit (Qiagen). Reverse-strand synthesis for sgRNAs was performed with qScript Flex cDNA kit (VWR) and custom first-strand synthesis primers (Tables J and K). qPCR analysis was performed with Fast SYBR Green Master Mix (Life Technologies) and custom primers (Tables J and K), using GAPDH as an endogenous control. Relative quantification was calculated by the ΔΔCT method.

TABLE I

Target site sequences. Tested target sites for <i>S. pyogenes</i> type II CRISPR system with the requisite PAM. Cells were transfected with Cas9 and either crRNA-tracrRNA or chimeric sgRNA for each target.				
Target site genomic ID	target	Target site sequence (5' to 3')	PAM	strand
1	EMX1	GTCACCTCCAATGACTAGGG (SEQ ID NO: 319)	TGG	+
2	EMX1	GACATCGATGTCCTCCCAT (SEQ ID NO: 196)	TGG	-
3	EMX1	GAGTCCGAGCAGAAGAAGAA (SEQ ID NO: 197)	GGG	+
6	EMX1	GCGCCACCGTTGATGTGAT (SEQ ID NO: 198)	GGG	-
10	EMX1	GGGGCACAGATGAGAACTC (SEQ ID NO: 199)	AGG	-
11	EMX1	GTACAAACGGCAGAAGCTGG (SEQ ID NO: 200)	AGG	+
12	EMX1	GGCAGAAGCTGGAGGAGGAA (SEQ ID NO: 201)	GGG	+
13	EMX1	GGAGCCCTTCTTCTTGCT (SEQ ID NO: 202)	CGG	-
14	EMX1	GGGCAACCACAAACCCACGA (SEQ ID NO: 203)	GGG	+
15	EMX1	GCTCCCATCACATCAACCGG (SEQ ID NO: 204)	TGG	+
16	EMX1	GTGGCGCATTGCCACGAAGC (SEQ ID NO: 205)	AGG	+
17	EMX1	GGCAGAGTGCTGCTGCTGC (SEQ ID NO: 206)	TGG	+
18	EMX1	GCCCCTGCGTGGCCCAAGC (SEQ ID NO: 207)	TGG	+

TABLE I-continued

Target site sequences. Tested target sites for <i>S. pyogenes</i> type II CRISPR system with the requisite PAM. Cells were transfected with Cas9 and either crRNA-tracrRNA or chimeric sgRNA for each target.				
Target site genomic ID	target	Target site sequence (5' to 3')	PAM strand	
19	EMX1	GAGTGGCCAGAGTCCAGCTT (SEQ ID NO: 208)	GGG	-
20	EMX1	GGCCTCCCCAAAGCCTGGCC (SEQ ID NO: 209)	AGG	-
4	PVALB	GGGGCCGAGATTGGGTGTTC (SEQ ID NO: 210)	AGG	+
5	PVALB	GTGGCGAGAGGGGCCGAGAT (SEQ ID NO: 211)	TGG	+
1	SERPINB5	GAGTGCCCGCAGGCGGGC (SEQ ID NO: 212)	GGG	+
2	SERPINB5	GGAGTGCCCGCAGGCGGG (SEQ ID NO: 213)	CGG	+
3	SERPINB5	GGAGAGGAGTGCCCGCAGG (SEQ ID NO: 214)	CGG	+

TABLE J

Primer sequences		
SURVEYOR assay		
primer name	genomic target	primer sequence (5' to 3')
Sp-EMX1-F1	EMX1	AAAACCCCTTCTCTCTGGC (SEQ ID NO: 36)
Sp-EMX1-R1	EMX1	GGAGATTGGAGACACGGAGAG (SEQ ID NO: 37)
Sp-EMX1-F2	EMX1	CCATCCCCTTCTGTGAATGT (SEQ ID NO: 215)
Sp-EMX1-R2	EMX1	GGAGATTGGAGACACGGAGA (SEQ ID NO: 216)
Sp-PVALB-F	PVALB	CTGGAAAGCCAATGCCTGAC (SEQ ID NO: 38)
Sp-PVALB-R	PVALB	GGCAGCAAACCTTGTCTCCT (SEQ ID NO: 39)
qRT-PCR for Cas9 and sgRNA expression		
primer name	primer sequence (5' to 3')	
sgRNA reverse-strand synthesis	AAGCACCGACTCGGTGCCAC (SEQ ID NO: 217)	
EMX1.1 sgRNA qPCR F	TCACCTCCAATGACTAGGGG (SEQ ID NO: 218)	
EMX1.1 sgRNA qPCR R	CAAGTTGATAACGGACTAGCCT (SEQ ID NO: 219)	

TABLE J-continued

Primer sequences	
EMX1.3 sgRNA qPCR F	AGTCCGAGCAGAAGAAGAAGTTT (SEQ ID NO: 220)
EMX1.3 sgRNA qPCR R	TTTCAAGTTGATAACGGACTAGCCT (SEQ ID NO: 221)
Cas9 qPCR F	AAACAGCAGATTGCGCTGGA (SEQ ID NO: 222)
Cas9 qPCR R	TCATCCGCTCGATGAAGCTC (SEQ ID NO: 223)
GAPDH qPCR F	TCCAAAATCAAGTGGGGCGA (SEQ ID NO: 224)
GAPDH qPCR R	TGATGACCCTTTTGGCTCCC (SEQ ID NO: 225)
Bisulfite PCR and sequencing	
primer name	primer sequence (5' to 3')
Bisulfite PCR F (SERPINB5 locus)	GAGGAATCTTTTTTGTTYGAATATGTTGGAGGT (SEQ ID NO: 226)
Bisulfite PCR R (SERPINB5 locus)	GAGAAGCTTAAATAAAAAACRACAATACTCAACC CAACAACC (SEQ ID NO: 227)
pUC19 sequencing	CAGGAAACAGCTATGAC (SEQ ID NO: 228)

TABLE K

Sequences for primers to test sgRNA architecture. Primers hybridize to the reverse strand of the U6 promoter unless otherwise indicated. The U6 priming site is in italics, the guide sequence is indicated as a stretch of Ns, the direct repeat sequence is highlighted in bold, and the tracrRNA sequence underlined. The secondary structure of each sgRNA architecture is shown in FIG. 43.

primer name	primer sequence (5' to 3')
U6-Forward	GCCTTAGAGGTACCTGAGGGCCTATTTCCCATGATTCC (SEQ ID NO: 229)
I: sgRNA(DR + 12, tracrRNA + 85)	ACCTCTAGAAAAAAGCACCGACTCGGTGCCACTTTTTCAAGT <i>TGATAACGGACTAGCCTTATTTAACTTGCTATTCTAGCTCT</i> AAAACNNNNNNNNNNNNNNNNNNNNNGGTGTTTCGTCCTTCC ACAAG (SEQ ID NO: 230)
II: sgRNA(DR + 12, tracrRNA + 85) mut2	ACCTCTAGAAAAAAGCACCGACTCGGTGCCACTTTTTCAAGT <i>TGATAACGGACTAGCCTTATATTAAGTCTATTCTAGCTCT</i> AATACNNNNNNNNNNNNNNNNNNNNNGGTGTTTCGTCCTTTCCA CAAG (SEQ ID NO: 231)
III: sgRNA(DR + 22, tracrRNA + 85)	ACCTCTAGAAAAAAGCACCGACTCGGTGCCACTTTTTCAAGT <i>TGATAACGGACTAGCCTTATTTAACTTGCTATGCTGTTTGTG</i> TCCAAAACAGCATAGCTCTAAAACNNNNNNNNNNNNNNNN NNNNGGTGTTTCGTCCTTTCCACAAG (SEQ ID NO: 232)
IV: sgRNA(DR + 22, tracrRNA + 85) mut4	ACCTCTAGAAAAAAGCACCGACTCGGTGCCACTTTTTCAAGT <i>TGATAACGGACTAGCCTTATATTAAGTCTATGCTGTATTGT</i> TTCCAATACAGCATAGCTCTAATACNNNNNNNNNNNNNNNN NNNNGGTGTTTCGTCCTTTCCACAAG (SEQ ID NO: 233)

TABLE L

Target sites with alternate PAMs for testing PAM specificity of Cas9. All target sites for PAM specificity testing are found within the human EMX1 locus.

Target site sequence (5' to 3')	PAM
AGGCCCCAGTGGCTGCTCT (SEQ ID NO: 234)	NAA
ACATCAACCGGTGGCGCAT (SEQ ID NO: 235)	NAT
AAGGTGTGGTTCCAGAACC (SEQ ID NO: 236)	NAC
CCATCACATCAACCGTGG (SEQ ID NO: 237)	NAG
AAACGGCAGAAGCTGGAGG (SEQ ID NO: 238)	NTA
GGCAGAAGCTGGAGGAGGA (SEQ ID NO: 239)	NTT
GGTGTGGTTCCAGAACCGG (SEQ ID NO: 240)	NTC
AACCGGAGGACAAAGTACA (SEQ ID NO: 241)	NTG
TTCCAGAACCGGAGGACAA (SEQ ID NO: 242)	NCA
GTGTGGTTCCAGAACCGGA (SEQ ID NO: 243)	NCT
TCCAGAACCGGAGGACAAA (SEQ ID NO: 244)	NCC
CAGAAGCTGGAGGAGGAAG (SEQ ID NO: 245)	NCG
CATCAACCGGTGGCGCATT (SEQ ID NO: 246)	NGA
GCAGAAGCTGGAGGAGGAA (SEQ ID NO: 247)	NGT
CCTCCCTCCCTGGCCCAGG (SEQ ID NO: 248)	NGC
TCATCTGTGCCCTCCCTC (SEQ ID NO: 249)	NAA

TABLE L-continued

Target sites with alternate PAMs for testing PAM specificity of Cas9. All target sites for PAM specificity testing are found within the human EMX1 locus.

Target site sequence (5' to 3')	PAM
GGGAGGACATCGATGTCAC (SEQ ID NO: 250)	NAT
CAAACGGCAGAAGCTGGAG (SEQ ID NO: 251)	NAC
GGGTGGGCAACCACAAACC (SEQ ID NO: 252)	NAG
GGTGGGCAACCACAAACC (SEQ ID NO: 253)	NTA
GGCTCCCATCACATCAACC (SEQ ID NO: 254)	NTT
GAAGGGCCTGAGTCCGAGC (SEQ ID NO: 255)	NTC
CAACCGGTGGCGCATTGCC (SEQ ID NO: 256)	NTG
AGGAGGAAGGCCTGAGTC (SEQ ID NO: 257)	NCA
AGCTGGAGGAGGAAGGGCC (SEQ ID NO: 258)	NCT
GCATTGCCACGAAGCAGGC (SEQ ID NO: 259)	NCC
ATTGCCACGAAGCAGGCCA (SEQ ID NO: 260)	NCG
AGAACCGGAGGACAAAGTA (SEQ ID NO: 261)	NGA
TCAACCGGTGGCGCATTGC (SEQ ID NO: 262)	NGT
GAAGCTGGAGGAGGAAGGG (SEQ ID NO: 263)	NGC

- continued

gcttaccgtaacttgaaagtatttcgatttcttgctttatatatcttctgtgaaaggacgaaacacNNNNNNNNNNNNNNNNNNNN

NNggttttgaggttggaaatagcaagttaaaataaggctagtcgctttatcaacttgaaaaagtggcaccgagtcggtgcTTTTTTT

(guide sequence is in bold Ns and the tracrRNA fragment is in bold)

CBh-NLS-SpCas9-NLS

(SEQ ID NO: 59)

CGTTACATAACTTACGGTAAATGGCCCGCCTGGCTGACCGCCCAACGACC

CCCGCCCATTGACGTCAATAATGACGTATGTTCCCATAGTAACGCCAATAGGGACTT

TCCATTGACGTCAATGGGTGAGTATTTACGGTAAACTGCCCACTTGGCAGTACATC

AAGTGATCATATGCCAAGTACGCCCCCTATTGACGTCAATGACGGTAAATGGCCCG

CCTGGCATTATGCCAGTACATGACCTTATGGGACTTTCCTACTTGGCAGTACATCTA

CGTATTAGTCATCGCTATTACCATGGTCGAGGTGAGCCCACTTCTGCTTCACTCTC

CCCATCTCCCCCCTCCCAACCCCAATTTGTATTTATTTATTTTTAATTATTTTG

TGCAGCGATGGGGCGGGGGGGGGGGGGGGCGCGCCAGGCGGGCGGGGCGG

GGCGAGGGCGGGGGCGGGCGAGGCGGAGAGGTGCGGCGGCAGCCAATCAGAGCG

GCGCGCTCCGAAAGTTTCTTTTATGGCGAGGCGGCGGCGGCGGCCCTATAAA

AAGCGAAGCGCGGGGGGGGAGTCGCTGCGACGCTGCCTTCGCCCGTGCCCC

GCTCCGCCCGCCTCGCGCCGCCCGCCCGGCTCTGACTGACCGGTTACTCCAC

AGGTGAGCGGGCGGACGCGCCCTTCTCCTCCGGGCTGTAATTAGCTGAGCAAGAGG

TAAGGGTTAAGGGATGGTTGGTTGGTGGGGTATTAATGTTAATTACCTGGAGCAC

CTGCCTGAAATCACTTTTTTTCAGGTTGGaccggtgccaccATGGACTATAAGGACCAG

ACGGAGACTACAAGGATCATGATATTGATTACAAAGACGATGACGATAAGATG

GCCCCAAAGAAGAAGCGGAAGGTCGGTATCCACGGAGTCCCAAGCAGCCGACAA

GAAGTACAGCATCGGCCTGGACATCGGCACCACTCTGTGGGCTGGGCGTGA

TCACCAGCAGTACAAGGTGCCAGCAAGAAATCAAGGTGCTGGGCAACACC

GACCGGCAAGCATCAAGAAGAACCCTGATCGGAGCCCTGCTGTTTCGACAGCGG

CGAAACAGCCGAGGCCACCCGGCTGAAGAGAACGCCAGAAGAAGATACCCA

GACGGAAGAACCGGATCTGCTATCTGCAAGAGATCTTCAGCAAAGAGATGGCC

AAGGTGGAAGCAGCAGCTTCTCCACAGACTGGAAGAGTCTTCTGTTGGAAGA

GGATAAGAAGCAGAGCGGCACCCCATCTTCGGCAACATCGTGGACGAGGTGG

CCTACCACGAGAAGTACCCCACTTCTACCACCTGAGAAAGAACTGGTGGAC

AGCACCGACAAGGCCGACCTGCGGCTGATCTATCTGGCCCTGGCCACATGAT

CAAGTTCGGGGCCACTTCCTGATCGAGGGCGACCTGAACCCGACAACAGCG

ACGTGGACAAGCTGTTTCCAGCTGGTGCAGACCTACAACCAGCTGTTTCGAG

GAAAACCCCATCAACGCCAGCGGCTGGACGCCAAGGCCATCCTGTCTGCCAG

ACTGAGCAAGAGCAGACGGCTGGAAAATCTGATCGCCAGCTGCCCGGCGAGA

AGAAGAATGGCCTGTTTCGGCAACCTGATTGCCCTGAGCCTGGGCTGACCCCC

AACTTCAAGAGCAACTTCGACCTGGCCGAGGATGCCAACTGCAGCTGAGCAA

GGACACCTACGACGACACCTGGACAACCTGCTGGCCAGATCGGCGACCACT

ACGCCGACCTGTTTCTGGCCGCAAGAACCTGTCGACGCCATCCTGCTGAGC

-continued

GACATCCTGAGAGTGAACACCGAGATCACCAAGGCCCTGAGCGCCTCTAT
GATCAAGAGATACGACGAGCACCCACGACCTGACCTGCTGAAAGCTCTCG
TGCGGCAGCAGCTGCCTGAGAAGTACAAAGAGATTTCTTCGACCAGAGCAAG
AACGGCTACGCCGGCTACATTGACGGCGGAGCCAGCCAGGAAGAGTTCTACAA
GTTTCATCAAGCCCATCCTGGAAGAGATGGACGGCACCGAGGAACTGCTCGTGA
AGCTGAACAGAGAGGACCTGCTGCGGAAGCAGCGGACCTTCGACAACGGCAG
CATCCCCCACCAGATCCACCTGGGAGAGCTGCACGCCATTCTGCGGGCGCAGG
AAGATTTTTTACCCATTCTGAAAGGACAACCGGGAAGATCGAGAAGATCCTG
ACCTTCGCGCATCCCCTACTACGTGGGCCCTCTGGCCAGGGGAAACAGCAGATT
CGCCTGGATGACCAGAAAGAGCGAGGAAACCATCACCCCTGGAACTTCGAGG
AAGTGGTGGACAAGGGCGCTTCGCGCCAGAGCTTCATCGAGCGGATGACCAAC
TTCGATAAGAACCCTGCCCAACGAGAAGGTGCTGCCAAGCACAGCCTGCTGTA
CGAGTACTTCACCGTGTATAACGAGCTGACCAAGTGAATACGTGACCGAGG
GAATGAGAAAGCCCGCTTCTGAGCGCGAGCAGAAAAGGCCATCGTGGAC
CTGCTGTTCAAGACCAACCGGAAAGTGACCGTGAAGCAGCTGAAAGAGGACTA
CTTCAAGAAAATCGAGTCTTACGACTCCGTGGAATCTCCGGCGTGGAAAGATC
GGTTCAACGCCTCCCTGGGCACATACCACGATCTGCTGAAAATATCAAGGAC
AAGGACTTCTGGACAAAGAGGAAAACGAGGACATTCTGGAAGATATCGTGCT
GACCTGACACTGTTGAGGACAGAGAGATGATCGAGGAACGGCTGAAAACCT
ATGCCACCTGTTGACGACAAAAGTGATGAAGCAGCTGAAGCGGCGGAGATAC
ACCGCTGGGGCAGGCTGAGCCGGAAGCTGATCAACGGCATCCGGGACAAGC
AGTCCGGCAAGACAATCCTGGATTTCTGAAAGTCCGACGGCTTCGCCAACAGA
AACTTCATGCAGCTGATCCACGACGACAGCCTGACCTTTAAGAGGACATCCA
GAAAGCCAGGTGTCGGCCAGGGCGATAGCCTGCAAGGACATTTGCCAATC
TGGCCGGCAGCCCCGCCATTAAGAAAGGGCATCCTGCAGACAGTGAAGTGGTG
GACGAGCTCGTGAAAGTGTGGCCGGCACAAAGCCGAGAACATCGTGATCGA
AATGGCCAGAGAGAACCAGACCAACCGAAGGGACAGAAAGAACGCCGCGAG
AGAAAGAAAGCGGATCGAAGAGGGCATCAAAGAGCTGGGCAGCCAGATCCTGAA
AGAACAACCCGTGGAAAACACCCAGCTGCAGAACGAGAAGCTGTACTGTA
ACCTGCAGAAATGGGCGGATATGTACGTGGACCGGAACTGGACATCAACCGG
CTGTCCGACTACGATGTGGACCATATCGTGCCTCAGAGCTTTCTGAAGGACGA
CTCCATCGACAAACAAGGTGCTGACCGAAGCGACAAAGAACCGGGCAAGAGCG
ACAACGTGCCCTCCGAAAGAGTGTGAAAGAGATGAAGAACTACTGGCGGAG
CTGCTGAAACGCCAAGCTGATTACCCAGAGAAAGTTCGACAATCTGACCAAGGC
CGAGAGAGGGCGCTGAGCGAACTGGATAAGGCCGGCTTCATCAAGAGACAG
CTGGTGGAAAACCGGCAGATCAAAAAGCACGTGGCACAGATCCTGGACTCCCG
GATGAACACTAAGTACGACGAGAAATGACAAGCTGATCCGGGAAGTGAAGTGA
TCACCTGAAGTCCAAGCTGGTGTCCGATTTCCGGAAGGATTTCCAGTTTTACA
AAGTGCAGGAGATCAACAACTACCAACCGCCACGACGCCTACCTGAAACGCC

-continued

GTCGTGGGAACCGCCCTGATCAAAAAGTACCCTAAGCTGGAAAACGAGTTCGT
GTACGGCGACTACAAGGTGTACGACGTGCGGAAGATGATCGCCAAGAGCGAGC
AGGAAATCGGCAAGGCTACCGCCAAGTACTTCTTCTACAGCAACATCATGAACT
TTTTCAAGACCGAGATTACCTGGCCAACGGCGAGATCCGGAAGCGGCCTCTG
ATCGAGACAAACGGCGAAAACCGGGGAGATCGTGTGGGATAAGGGCCGGGAT
TGGCCACCGTGCAGGAAAAGTGTGAGCATGCCCAAGTGAATATCGTAAAAAG
ACCGAGGTGCAGACAGGCGGCTTACGAAAAGAGTCTATCCTGCCAAGAGGAA
CAGCGATAAGCTGATCGCCAGAAAAGAGGACTGGGACCCTAAGAAGTACGGCG
GCTTTCGACAGCCCCACCGTGGCCTATTCTGTGCTGGTGGTGGCCAAAGTGGAA
AAGGGCAAGTCCAAGAACTGAAAGAGTGTGAAAGAGCTGCTGGGGATCACCAT
CATGGAAAAGAAGCAGCTTCGAGAAGAATCCCATCGACTTTCGGAAGCCAAGG
GCTACAAAAGAAGTAAAAAGGACCTGATCATCAAGCTGCCTAAGTACTCCCTG
TTCGAGCTGGAAAACGGCCGGAAGAGAATGCTGGCCTGCGCGGCGAACTGCA
GAAGGAAAACGAACTGGCCCTGCCCTCCAAATATGTGAACTTCTGTACCTGG
CCAGCCACTATGAGAAGCTGAAGGGCTCCCCGAGGATAATGAGCAGAAACAG
CTGTTTGTGGAACAGCACAAGCACTACCTGGACGAGATCATCGAGCAGATCAG
CGAGTTCTCCAAGAGAGTGATCCTGGCCGACGCTAATCTGGACAAAAGTGTGT
CCGCTACAAACAGCACCAGGATAAGCCATCAGAGAGCAGGCCGAGAATATC
ATCCACCTGTTTACCCTGACCAATCTGGGAGCCCCTGCCGCTTCAAGTACTTT
GACACCACCATCGACCGGAAGAGGTACACCAGCACCAAAGAGGTGCTGGACGC
CACCTGATCCACCAGAGCATCACCGGCCTGTACGAGACCGGATCGACCTGT
CTCAGCTGGGAGGCGACTTTCCTTTTCTTAGCTTGACCAGCTTTCCTTAGTAGCA
GCAGGACGCTTTAA

(NLS-hSpCas9-NLS is highlighted in **bold**)

Sequencing amplicon for EMX1 guides 1.1, 1.14, 1.17

(SEQ ID NO: 264)

CCAATGGGGAGGACATCGATGTCACCTCCAATGACTAGGGTGGCAACC
ACAAACCCACGAGGGCAGAGTGCTGCTGCTGCTGGCCAGGCCCTGCGTGGGCCC
AAGCTGGACTCTGGCCAC

Sequencing amplicon for EMX1 guides 1.2, 1.16

(SEQ ID NO: 265)

CGAGCAGAAGAAGAAGGGCTCCCATCACATCAACCGGTGGCGCATTGCC
ACGAAGCAGGCCAATGGGGAGGACATCGATGTCACCTCCAATGACTAGGGTGGGCA
ACCACAAACCCACGAG

Sequencing amplicon for EMX1 guides 1.3, 1.13, 1.15

(SEQ ID NO: 266)

GGAGGACAAAGTACAAACGGCAGAAGCTGGAGGAGGAAGGGCCTGAGTC
CGAGCAGAAGAAGAAGGGCTCCCATCACATCAACCGGTGGCGCATTGCCACGAAGC
AGGCCAATGGGGAGGACATCGAT

-continued

>Sequencing amplicon for EMX1 guides 1.6 (SEQ ID NO: 267)
 AGAAGCTGGAGGAGGAAGGGCCTGAGTCCGAGCAGAAGAAGAAGGGCTC
 CCATCACATCAACCGGTGGCGCATTGCCACGAAGCAGGCCAATGGGGAGGACATCG
 ATGTCACTCCAATGACTAGGGTGG

Sequencing amplicon for EMX1 guides 1.10 (SEQ ID NO: 268)
 CCTCAGTCTTCCCATCAGGCTCTCAGCTCAGCCTGAGTGTGAGGCCCCAG
 TGGCTGCTCTGGGGCCTCCTGAGTTTCTCATCTGTGCCCTCCCTCCCTGGCCAGG
 TGAAGGTGTGGTTCCA

Sequencing amplicon for EMX1 guides 1.11, 1.12 (SEQ ID NO: 269)
 TCATCTGTGCCCTCCCTCCCTGGCCAGGTGAAGGTGTGGTTCCAGAACC
 GGAGGACAAAGTACAAACGGCAGAAGCTGGAGGAGGAAGGGCCTGAGTCCGAGCA
 GAAGAAGAAGGGCTCCCATCACA

Sequencing amplicon for EMX1 guides 1.18, 1.19 (SEQ ID NO: 270)
 CTCCAATGACTAGGGTGGGCAACCACAAACCCACGAGGGCAGAGTGTCTG
 CTTGTGTGTCAGCCAGGCCCTGCGTGGGCCCAAGCTGGACTCTGGCCACTCCCTGGC
 CAGGCTTTGGGGAGGCCTGGAGT

Sequencing amplicon for EMX1 guides 1.20 (SEQ ID NO: 271)
 CTGCTTGCTGTGCTGGCCAGGCCCTGCGTGGGCCCAAGCTGGACTCTGGCC
 ACTCCCTGGCCAGGCTTTGGGGAGGCCTGGAGTCATGGCCCCACAGGGCTTGAAGC
 CCGGGGCCCGCCATTGACAGAG

T7 promoter F primer for annealing with target strand (SEQ ID NO: 272)
 GAAATTAATACGACTCACTATAGGG

oligo containing pUC19 target site 1 for methylation (T7 reverse) (SEQ ID NO: 273)
 AAAAAAGCACCGACTCGGTGCCACTTTTTCAAGTTGATAACGGACTAGCC
 TTATTTTAACTTGCTATTTCTAGCTCTAAAACAACGACGAGCGTGACACCACCTAT
 AGTGAGTCGTATTAATTTT

oligo containing pUC19 target site 2 for methylation (T7 reverse) (SEQ ID NO: 274)
 AAAAAAGCACCGACTCGGTGCCACTTTTTCAAGTTGATAACGGACTAGCC
 TTATTTTAACTTGCTATTTCTAGCTCTAAAACGCAACAATTAATAGACTGGACCTATA
 GTGAGTCGTATTAATTTT

Example 11: Oligo-Mediated Cas9-Induced Homologous Recombination

[0358] The oligo homologous recombination test is a comparison of efficiency across different Cas9 variants and different HR template (oligo vs. plasmid).

[0359] 293FT cells were used. SpCas9=Wildtype Cas9 and SpCas9n=nickase Cas9 (D10A). The chimeric RNA target is the same EMX1 Protospacer Target 1 as in Examples 5, 9 and 10 and oligos synthesized by IDT using PAGE purification.

[0360] FIG. 44 depicts a design of the oligo DNA used as Homologous Recombination (HR) template in this experiment. Long oligos contain 100 bp homology to the EMX1

locus and a HindIII restriction site. 293FT cells were co-transfected with: first, a plasmid containing a chimeric RNA targeting human EMX1 locus and wild-type cas9 protein, and second, the oligo DNA as HR template. Samples are from 293FT cells collected 96 hours post transfection with Lipofectamine 2000. All products were amplified with an EMX1 HR Primer, gel purified, followed by digestion with HindIII to detect the efficiency of integration of HR template into the human genome.

[0361] FIGS. 45 and 46 depict a comparison of HR efficiency induced by different combination of Cas9 protein and HR template. The Cas9 construct used were either wild-type Cas9 or the nickase version of Cas9 (Cas9n). The HR template used were: antisense oligo DNA (Antisense-

Oligo in above figure), or sense oligo DNA (Sense-Oligo in above figure), or plasmid HR template (HR template in above figure). The sense/anti-sense definition is that the actively-transcribed strand with sequence corresponding to the transcribed mRNA is defined as the sense strand of genome. HR Efficiency is shown as percentage of HindIII digestion band as against all genomic PCR amplified product (bottom numbers).

Example 12: Autistic Mouse

[0362] Recent large-scale sequencing initiatives have produced a large number of genes associated with disease. Discovering the genes is only the beginning in understanding what the gene does and how it leads to a diseased phenotype. Current technologies and approaches to study candidate genes are slow and laborious. The gold standards, gene targeting and genetic knockouts, require a significant investment in time and resources, both monetary and in terms of research personnel. Applicants set out to utilize the hSpCas9 nuclease to target many genes and do so with higher efficiency and lower turnaround compared to any other technology. Because of the high efficiency of hSpCas9 Applicants can do RNA injection into mouse zygotes and immediately get genome-modified animals without the need to do any preliminary gene targeting in mESCs.

[0363] Chromodomain helicase DNA binding protein 8 (CHD8) is a pivotal gene involved in early vertebrate development and morphogenesis. Mice lacking CHD8 die during embryonic development. Mutations in the CHD8 gene have been associated with autism spectrum disorder in humans. This association was made in three different papers published simultaneously in Nature. The same three studies identified a plethora of genes associated with autism spectrum disorder. Applicants' aim was to create knockout mice for the four genes that were found in all papers, Chd8, Katnal2, Kctd13, and Scn2a. In addition, Applicants chose two other genes associated with autism spectrum disorder, schizophrenia, and ADHD, GIT1, CACNA1C, and CACNB2. And finally, as a positive control Applicants decide to target MeCP2.

[0364] For each gene Applicants designed three gRNAs that would likely knockout the gene. A knockout would occur after the hSpCas9 nuclease makes a double strand break and the error prone DNA repair pathway, non-homologous end joining, corrects the break, creating a mutation. The most likely result is a frameshift mutation that would knockout the gene. The targeting strategy involved finding proto-spacers in the exons of the gene that had a PAM sequence, NGG, and was unique in the genome. Preference was given to proto-spacers in the first exon, which would be most deleterious to the gene.

[0365] Each gRNA was validated in the mouse cell line, Neuro-N2a, by liposomal transient co-transfection with hSpCas9. 72 hours post-transfection genomic DNA was purified using QuickExtract DNA from Epicentre. PCR was performed to amplify the locus of interest. Subsequently the SURVEYOR Mutation Detection Kit from Transgenomics was followed. The SURVEYOR results for each gRNA and respective controls are shown in Figure A1. A positive SURVEYOR result is one large band corresponding to the genomic PCR and two smaller bands that are the product of the SURVEYOR nuclease making a double-strand break at the site of a mutation. The average cutting efficiency of each gRNA was also determined for each gRNA. The gRNA that

was chosen for injection was the highest efficiency gRNA that was the most unique within the genome.

[0366] RNA (hSpCas9+gRNA RNA) was injected into the pronucleus of a zygote and later transplanted into a foster mother. Mothers were allowed to go full term and pups were sampled by tail snip 10 days postnatal. DNA was extracted and used as a template for PCR, which was then processed by SURVEYOR. Additionally, PCR products were sent for sequencing. Animals that were detected as being positive in either the SURVEYOR assay or PCR sequencing would have their genomic PCR products cloned into a pUC19 vector and sequenced to determine putative mutations from each allele.

[0367] So far, mice pups from the Chd8 targeting experiment have been fully processed up to the point of allele sequencing. The Surveyor results for 38 live pups (lanes 1-38) 1 dead pup (lane 39) and 1 wild-type pup for comparison (lane 40) are shown in Figure A2. Pups 1-19 were injected with gRNA Chd8.2 and pups 20-38 were injected with gRNA Chd8.3. Of the 38 live pups, 13 were positive for a mutation. The one dead pup also had a mutation. There was no mutation detected in the wild-type sample. Genomic PCR sequencing was consistent with the SURVEYOR assay findings.

Example 13: CRISPR/Cas-Mediated Transcriptional Modulation

[0368] FIG. 67 depicts a design of the CRISPR-TF (Transcription Factor) with transcriptional activation activity. The chimeric RNA is expressed by U6 promoter, while a human-codon-optimized, double-mutant version of the Cas9 protein (hSpCas9m), operably linked to triple NLS and a VP64 functional domain is expressed by a EF1 α promoter. The double mutations, D10A and H840A, renders the cas9 protein unable to introduce any cleavage but maintained its capacity to bind to target DNA when guided by the chimeric RNA.

[0369] FIG. 68 depicts transcriptional activation of the human SOX2 gene with CRISPR-TF system (Chimeric RNA and the Cas9-NLS-VP64 fusion protein). 293FT cells were transfected with plasmids bearing two components: (1) U6-driven different chimeric RNAs targeting 20-bp sequences within or around the human SOX2 genomic locus, and (2) EF1 α -driven hSpCas9m (double mutant)-NLS-VP64 fusion protein. 96 hours post transfection, 293FT cells were harvested and the level of activation is measured by the induction of mRNA expression using a qRT-PCR assay. All expression levels are normalized against the control group (grey bar), which represents results from cells transfected with the CRISPR-TF backbone plasmid without chimeric RNA. The qRT-PCR probes used for detecting the SOX2 mRNA is Taqman Human Gene Expression Assay (Life Technologies). All experiments represents data from 3 biological replicates, n=3, error bars show s.e.m.

Example 14: NLS: Cas9 NLS

[0370] 293FT cells were transfected with plasmid containing two components: (1) EF1 α promoter driving the expression of Cas9 (wild-type human-codon-optimized Sp Cas9) with different NLS designs (2) U6 promoter driving the same chimeric RNA targeting human EMX1 locus.

[0371] Cells were collect at 72 h time point post transfection, and then extracted with 50 μ l of the QuickExtract

genomic DNA extraction solution following manufacturer's protocol. Target EMX1 genomic DNA were PCR amplified and then Gel-purify with 1% agarose gel. Genomic PCR product were re-anneal and subjected to the Surveyor assay following manufacturer's protocol. The genomic cleavage efficiency of different constructs were measured using SDS-PAGE on a 4-12% TBE-PAGE gel (Life Technologies), analyzed and quantified with ImageLab (Bio-rad) software, all following manufacturer's protocol.

[0372] FIG. 69 depicts a design of different Cas9 NLS constructs. All Cas9 were the human-codon-optimized version of the Sp Cas9. NLS sequences are linked to the cas9 gene at either N-terminus or C-terminus. All Cas9 variants with different NLS designs were cloned into a backbone vector containing so it is driven by EF1 α promoter. On the same vector there is a chimeric RNA targeting human EMX1 locus driven by U6 promoter, together forming a two-component system.

[0379] Sequence for a cassette driving the expression of Cas9 under the control of beta-2 tubulin promoter, followed by the 3' UTR of Cop1.

(SEQ ID NO: 275)

TCTTTCTTGGCCTATGACACTTCCAGCAAAAAGGTAGGGCGGGCTGCGAGA
 CGGCTTCCCGGCGCTGCATGCAACACCCGATGATGCTTGCAGCCCCGGAAG
 CTCCTTCGGGGTGCATGGGCGCTCCGATGCCGCTCCAGGGCGAGCGCTG
 TTTAAATAGCCAGGCCCCCGATTGCAAAGACATTATAGCGAGCTACCAAA
 GCCATATTCAAACACCTAGATCACTACCACCTTCTACACAGGCCACTCGAG
 CTTGTGATCGCACTCCGCTAAGGGGGCGCCTCTTCTCTTCGTTTCAGTC
 ACAACCCGCAACATGTACCACATACGATGTTCCAGATTACGCTTCGCCGA

TABLE M

Cas9 NLS Design Test Results. Quantification of genomic cleavage of different cas9-nls constructs by surveyor assay.

Percentage Genome Cleavage as measured by Surveyor assay	Biological Replicate 1 (%)	Biological Replicate 2 (%)	Biological Replicate 3 (%)	Average (%)	Error (S.E.M., standard error of the mean)
Cas9 (No NLS)	2.50	3.30	2.73	2.84	0.24
Cas9 with N-term NLS	7.61	6.29	5.46	6.45	0.63
Cas9 with C-term NLS	5.75	4.86	4.70	5.10	0.33
Cas9 with Double (N-term and C-term) NLS	9.08	9.85	7.78	8.90	0.60

[0373] FIG. 70 depicts the efficiency of genomic cleavage induced by Cas9 variants bearing different NLS designs. The percentage indicate the portion of human EMX1 genomic DNA that were cleaved by each construct. All experiments are from 3 biological replicates. n=3, error indicates S.E.M.

Example 15: Engineering of Microalgae Using Cas9

[0374] Methods of Delivering Cas9

[0375] Method 1: Applicants deliver Cas9 and guide RNA using a vector that expresses Cas9 under the control of a constitutive promoter such as Hsp70A-Rbc S2 or Beta2-tubulin.

[0376] Method 2: Applicants deliver Cas9 and T7 polymerase using vectors that expresses Cas9 and T7 polymerase under the control of a constitutive promoter such as Hsp70A-Rbc S2 or Beta2-tubulin. Guide RNA will be delivered using a vector containing T7 promoter driving the guide RNA.

[0377] Method 3: Applicants deliver Cas9 mRNA and in vitro transcribed guide RNA to algae cells. RNA can be in vitro transcribed. Cas9 mRNA will consist of the coding region for Cas9 as well as 3'UTR from Cop1 to ensure stabilization of the Cas9 mRNA.

[0378] For Homologous recombination, Applicants provide an additional homology directed repair template.

-continued

AGAAAAAGCGCAAGGTGCAAGCGTCCGACAAGAAGTACAGCATCGGCCGTG
 GACATCGGCACCACTCTGTGGGCTGGGCCGTGATCACCAGCAGGTACAA
 GGTGCCAGCAAGAAATTCAAGGTGCTGGGCAACACCGACCGGCACAGCA
 TCAAGAAGAACCCTGATCGGAGCCCTGTGTTTCAGCAGCGCGCAACAGCC
 GAGGCCACCCGGCTGAAGAGAACCGCCAGAAGAAGATACACCAGACGGAA
 GAACCGGATCTGCTATCTGCAAGAGATCTTCAGCAACGAGATGGCCAAGG
 TGGACGACAGCTTCTCCACAGACTGGAAGAGTCTTCTCTGGTGAAGAG
 GATAAGAAGCACGAGCGGCACCCATCTTCGGCAACATCGTGGACGAGGT
 GGCCCTACCACGAGAAGTACCCACCATCTACCACCTGAGAAAGAACTGG
 TGGACAGCACCGACAAGGCCGACCTGCGGCTGATCTATCTGGCCCTGGCC
 CACATGATCAAGTTCGGGGCCACTTCTGTATCGAGGGCGACCTGAACCC
 CGACAACAGCGACGTGGACAAGCTGTTTCATCCAGCTGGTGCAGACCTACA
 ACCAGCTGTTTCGAGGAAAACCCATCAACCGCCAGCGGCTGGACGCCAAG
 GCCATCCTGTCTGCCAGACTGAGCAAGAGCAGACGGCTGGAAAATCTGAT
 CGCCACAGCTGCCCGGCGAGAAGAAGATGGCTGTTTCGGCAACCTGATTG
 CCCTGAGCCTGGGCTGACCCCCAACTTCAAGAGCAACTTCGACCTGGCC
 GAGGATGCCAAACTGCAGCTGAGCAAGGACACCTACGACGACGACCTGGA

-continued

CAACCTGTGGCCAGATCGGCGACCAGTACGCCGACCTGTTTCTGGCCG
 CCAAGAACCTGTCCGACGCCATCCTGCTGAGCGACATCCTGAGAGTGAAC
 ACCGAGATCACCAAGGCCCCCTGAGCGCCTCTATGATCAAGAGATACGA
 CGAGACACCACAGGACCTGACCTGCTGAAAGCTCTCGTGGCAGCAGC
 TGCTGAGAAGTACAAAGAGATTTTCTTCGACACGAGCAAGAACGGCTAC
 GCCGGCTACATTGACGGCGGAGCCAGCCAGGAAGAGTTCTACAAGTTCAT
 CAAGCCATCCTGAAAAGATGGACGGCACCAGGAAGTCTCGTGAAGC
 TGAACAGAGAGACCTGCTGCGGAAGCAGCGGACCTTCGACAACGGCAGC
 ATCCCCACAGATCCACCTGGGAGAGTGCACGCCATTCCTGGCGGCA
 GGAAGATTTTACCATTCTGAAAGACAACCGGAAAAGATCGAGAAGA
 TCCTGACCTTCCGCATCCCTACTACGTGGGCCCTCTGGCCAGGGAAAAC
 AGCAGATTCGCTGGATGACCAGAAGAGCGAGGAAACCATACCCCTG
 GAACCTCGAGGAAGTGGTGGACAAGGGCGCTTCCGCCAGAGCTTCATCG
 AGCGGATGACCAACTTCGATAAGAACC TGCCCAACGAGAAGTGTGCC
 AAGCAGCCTGCTGTACGAGTACTTCACCGTGTATAACGAGCTGACCAA
 AGTGAATAACGTGACCGAGGGAATGAGAAAAGCCCGCTTCTGAGCGGCG
 AGCAGAAAAGGCCATCGTGGACCTGCTGTTCAAGACCAACCGAAAAGTG
 ACCGTGAAGCAGCTGAAAGAGGACTACTTCAAGAAAATCGAGTGTTCGA
 CTCCTGGAAATCTCCGCGTGGAAAGATCGGTTCAACGCCCTCCCTGGGCA
 CATAACCAGATCTGCTGAAAATTATCAAGGACAAGGACTTCCTGGACAAT
 GAGGAAAACGAGGACATTCGGAAGATATCGTGTGACCTGACACTGTT
 TGAGGACAGAGAGATGATCGAGGAACGGCTGAAAACCTATGCCACCTGT
 TCGACGACAAAGTGATGAAGCAGCTGAAGCGGCGGAGATACACCGGCTGG
 GGCAGGCTGAGCCGGAAGCTGATCAACGGCATCCGGGACAAGCAGTCCGG
 CAAGACAATCCTGGATTTCTGAACTCCGACGGCTTCCGCAACAGAACT
 TCATGCAGCTGATCCACGACGACAGCTGACCTTTAAAGAGGACATCCAG
 AAAGCCAGGTGTCCGGCCAGGGCGATAGCCTGCACGACACATTGCCAA
 TCTGGCCGGCAGCCCGCCATTAAGAAGGGCATCCTGCAGACAGTGAAGG
 TGGTGGACGAGCTCGTGAAGTGATGGGCCGGCACAAGCCCGAGAACATC
 GTGATCGAAATGGCCAGAGAGAACCAGACCACCCAGAAGGGACAGAAGAA
 CAGCCGCGAGAGAAATGAAGCGGATCGAAGAGGGCATCAAAGAGCTGGGCA
 GCCAGATCCTGAAAGAACACCCCGTGGAAAACACCCAGCTGCAGAACGAG
 AAGCTGTACTGTACTACCTGCAGAATGGCGGGATATGTACGTGGACCA
 GGAACCTGGACATCAACCGGCTGTCGACTACGATGTGGACCATATCGTGC
 CTCAGAGCTTCTGAAGGACGACTCCATCGACAACAAGGTGCTGACCAGA
 AGCGACAAGAACCAGGGCAAGAGCGACAACCTGCCTCCGAAGAGGTGCT
 GAAGAAGATGAAGAATACTGGCGGCGAGCTGCTGAACGCCAAGCTGATTA
 CCCAGAGAAAGTTCGACAATCTGACCAAGGCCGAGAGAGGCGGCTGAGC
 GAACCTGGATAAGGCCGCTTTCATCAAGAGACAGCTGGTGGAAAACCGGCA

-continued

GATCACAAAAGCACGTGGCACAGATCCTGGACTCCCGGATGAACACTAAGT
 ACGACGAGAATGACAAGCTGATCCGGGAAGTGAAGTATCACCCTGAAG
 TCCAAGCTGGTGTCCGATTTCCGGAAGGATTTCCAGTTTTACAAAGTGCCG
 CGAGATCAACAACACTACCACCACGCCCACGACGCCACCTGAACGCCGCTCG
 TGGGAACCGCCCTGATCAAAAAGTACCCTAAGCTGAAAAGCGAGTTCGTG
 TACGGCGACTACAAGGTGTACGACGTGCGGAAGATGATCGCCAGAGCGCA
 GCAGGAAATCGGCAAGGCTACCGCAAGTACTTCTTCTACAGCAACATCA
 TGAACTTTTTCAAGACCGAGATTACCTGGCCAACCGGCGAGATCCGGAAG
 CGGCCCTGATCGAGACAACGGCGAAAACCGGGGAGATCGTGTGGGATAA
 GGGCCGGGATTTTGCCACCCTGCGGAAAAGTGTGAGCATGCCCAAGTGA
 ATATCGTGA AAAAGACCAGGTGCAGACAGGCGGCTTCAGCAAAAGAGTCT
 ATCTGCCCAAGAGGAACAGCGATAAGCTGATCGCCAGAAAAGAGGACTG
 GGACCCTAAGAAGTACGGCGGCTTCGACAGCCCCACCGTGGCTATTCTG
 TGCTGGTGGTGGCCAAAGTGGAAAAGGGCAAGTCCAAGAACTGAAGAGT
 GTGAAAGAGCTGCTGGGATCACCATCATGGAAGAAGCAGCTTCGAGAA
 GAATCCCATCGACTTCTGGAAGCCAAGGGCTACAAAGAAGTGA AAAAGG
 ACCTGATCATCAAGCTGCCTAAGTACTCCCTGTTCGAGCTGAAAACGGC
 CGGAAGAGAATGCTGGCCTCTGCCGGCGAACTGCAGAAGGGAAACGAACT
 GGCCCTGCCCTCCAATATGTGAACTTCTGTACTGGCCAGCCACTATG
 AGAAGCTGAAGGGCTCCCCGAGGATAATGAGCAGAAACAGCTGTTTGTG
 GAACAGCACAAGCACTACCTGGACGAGATCATCGAGCAGATCAGCGAGTT
 CTCCAAGAGAGTGATCCTGGCCGACGCTAATCTGGACAAGAGTGTGTCG
 CCTACAACAAGCACCAGGATAAGCCCATCAGAGAGCAGGCCGAGAAATATC
 ATCCACCTGTTTACCCTGACCAATCTGGGAGCCCTGCCGCTTCAAGTA
 CTTTGACACCACCATCGACCGGAAGAGGTACACCAGCACCAAAAGAGGTGC
 TGGACGCCACCCTGATCCACCAGAGCATCACCGGCTGTACGAGACACGG
 ATCGACCTGTCTCAGCTGGGAGGCGACAGCCCCAAGAAGAAGAGAAAGGT
 GGAGGCCAGCTAAGGATCCGGCAAGACTGGCCCCGCTTGGCAACGCAACA
 GTGAGCCCCCTCCCTAGTGTGTTGGGGATGTGACTATGTATTCGTGTGTT
 GGCCAACGGGTCAACCCGAACAGATTGATACCCGCTTGGCATTTCCTGT
 CAGAATGTAACGTCAGTTGATGGTACT

[0380] Sequence for a cassette driving the expression of T7 polymerase under the control of beta-2 tubulin promoter, followed by the 3' UTR of Cop1:

(SEQ ID NO: 276)
 TCTTTCTTGCCTATGACACTTCCAGCAAAAAGGTAGGGCGGCTGCGAGA
 CGGCTTCCCGGCGCTGCATGCAACACCCGATGATGCTTCGACCCCCGAAG
 CTCTTCCGGGCTGCATGGGCGCTCCGATGCCGCTCCAGGGCGAGCGCTG
 TTTAAATAGCCAGGCCCGGATTGCAAAGACATTATAGCGAGCTACCAAA

-continued

ATGAGATTATCAAAAAGGATCTTCACCTAGATCCTTTTAAATTAATAAATG
AAGTTTTAAATCAATCTAAAGTATATATAGTAAACTTGGTCTGACAGTT
ACCAATGCTTAATCAGTGAGGCACCTATCTCAGCGATCTGTCTATTTTCGT
TCATCCATAGTTGCCTGACTCCCCGTCGTGTAGATAACTACGATACGGGA
GGGCTTACCATCTGGCCCCAGTGCTGCAATGATACCGCGAGACCCACGCT
CACCGGCTCCAGATTTATCAGCAATAAACAGCCAGCCGGAAGGGCCGAG
CGCAGAAGTGGTCTCGCAACTTTATCCGCTCCATCCAGTCTATTAATTG
TTGCCGGGAAGCTAGAGTAAGTAGTTCCGCCAGTTAATAGTTTGCACAACG
TTGTTGCCATGTCTACAGGCATCGTGGTGTACGCTCGTCTGTTGGTATG
GCTTCATTAGCTCCGGTCCCAACGATCAAGGCGAGTTACATGATCCCC
CATGTTGTGCAAAAAGCGTTAGCTCCTTCGGTCCCTCCGATCGTTGTCA
GAAGTAAGTTGGCCGAGTGTATCACTCATGGTTATGCGAGCACTGCAT
AATTCTCTTACTGTATGCCATCCGTAAGATGCTTTTCTGTACTGGTGA
GTACTCAACCAAGTCATCTGAGAATAGTGTATGCGGCGACCGAGTTGCT
CTTGCCCGCGCTCAATACGGGATAATACCGGCCACATAGCAGAACTTTA
AAAGTGCTCATCATGGAAGCGTTCTTCGGGGCGAAAACCTCAAGGAT
CTTACCGCTGTTGAGATCCAGTTCGATGTAACCCACTCGTGCACCCAAC
GATCTTCAGCATCTTTACTTTTACCAGCGTTTCTGGGTGAGCAAAAACA
GGAAGGCAAAAATGCGCAAAAAGGGAATAAGGGCGACACGGAATGTTG
AATACTCATACTCTTCTTTTCAATATTATTGAAGCATTATCAGGGTT
ATTGTCTCATGACAAAATCCCTTAACGTGAGTTTTCTGTTCCACTGAGCG
TCAGACCCCGTAGAAAAGATCAAGGATCTTCTTGAGATCCTTTTTTTCT
GCGCGTAATCTGTCTGCTTGCAAAACAAAAAACACCGCTACCAGCGGTGG
TTTGTTCGCGGATCAAGAGCTACCAACTCTTTTTCCGAAGGTAACCTGGC
TTCAGCAGAGCGCAGATACCAATACTGTTCTTCTAGTGTAGCCGTAGTT
AGGCCACCACTTCAAGAACTCTGTAGCACCGCTACATACCTCGTCTGTC
TAATCCTGTTACAGTGGCTGTTGCCAGTGGCGATAAGTCTGTCTTACC
GGGTTGGACTCAAGACGATAGTTACCGGATAAGGCGCAGCGTCCGGGCTG
AACGGGGGTTCTGTGCACACAGCCAGCTTGAGCGAACGACCTACACCG
AACTGAGATACCTACAGCGTGAGCTATGAGAAAGCGCCACGCTTCCCGAA
GGGAGAAAGGCGGACAGGTATCCGTAAGCGCGAGGGTCCGGAACAGGAGA
GCGCACGAGGGAGCTTCCAGGGGAAACGCTGGTATCTTTATAGTCTGT
TCGGGTTTCGCCACCTCTGACTTGAGCGTGCATTTTTGTGATGCTCGTCA
GGGGGCGGAGCTATGAAAAACGCCAGCAACGCGCTTTTTACGGTT
CCTGGCTTTTTGCTGGCTTTTTGCTCACATGTTCTTTCTGCGTTATCCC
CTGATTCTGTGGATAACCGTATTACCGCTTTGAGTGAGCTGATACCGCT
CGCCCGAGCCGACACCGAGCGCAGCGAGTCAAGTGCAGGAGGAGCGGT
CGCTGAGGCTTGACATGATGGTGCATGTTTGTATGAAGTACAGGAC
TGATTTGGCGGCTATGAGGGCGGGGAAGCTCTGGAAGGGCCGCGATGG

-continued

GGCGCGCGGCTCCAGAAGGCGCCATACGGCCCGTGGCGGCACCCATCC
GGTATAAAAAGCCCGCAGCCCGAACGGTGACCTCCACTTTCAGCGACAAA
CGAGCACTTATACATACGCGACTATTCTGCGCTATACATAACCACTCAG
CTAGCTTAAGATCCCATCAAGCTTGCATGCCGGGCGCGCCAGAAGGAGCG
CAGCCAAACCAGGATGATGTTTGTGATGGGGTATTTGAGCACTTGCAACCT
TATCCGGAAGCCCTGGCCACAAAGGCTAGGCGCCATGCAAGCAGTT
CGCATGCAGCCCTGGAGCGGTGCCCTCTGATAAACGGCCAGGGGGCC
TATGTTCTTTACTTTTTTACAAGAGAAGTCACTCAACATCTTAAATGGC
CAGGTGAGTCGACGAGCAAGCCCGCGGATCAGGCAGCGTGTTCAGAT
TTGACTTGCAACGCCCGCATTGTGTCGACGAAGGCTTTTGCTCCTCTGT
CGCTGTCTCAAGCAGCATCTAACCTGCGTCGCGTTTCCATTTGCAGGA
GATTCGAGGTACCATGTACCCATACGATGTTCCAGATTACGCTTCGCCGA
AGAAAAAGCGCAAGGTCGAAGCGTCCGACAAGAAGTACAGCATCGGCCG
GACATCGGCACCAACTCTGTGGGCTGGGCGTGTACCCGACGAGTACAA
GGTGCCAGCAAGAAATCAAGGTGCTGGGCAACACCGACCGGCACAGCA
TCAAGAAGAACCTGATCGGAGCCCTGTGTTTCGACAGCGGCGAAAACGCC
GAGGCCACCCGGCTGAAGAGAACCAGCCAGAAGAAGATACACAGACGGAA
GAACCGGATCTGCTATCTGCAAGAGATCTTACGCAACGAGATGGCCAAGG
TGGACGACAGCTTCTTCCACAGACTGGAAGAGTCTTCTGTTGGGAAGAG
GATAAGAAGCACGAGCGGCACCCATCTTCGGCAACATCGTGGACGAGGT
GGCTTACCAGGAGAAGTACCCACCATCTACCCACTGAGAAGAAACTGG
TGGACAGCACCGGCAAGGCGACCTGCGGCTGATCTATCTGGCCCTGGCC
CACATGATCAAGTTCGGGGCCACTTCTGATCGAGGGCGACCTGAACCC
CGACAACAGCGACGTGGACAAGCTGTTTATCCAGTGGTGCAGACTACA
ACCAGCTGTTTCGAGGAAAACCCATCAACGCCAGCGCGTGGACGCCAAG
GCCATCTGTCTGCCAGACTGAGCAAGAGCAGACGGCTGGAAAATCTGAT
CGCCAGCTGCCCCGGCGAGAAGAAGTGGCTGTTCCGGCAACCTGATTG
CCCTGAGCCTGGGCTGACCCCAACTTCAAGAGCAACTTCGACCTGGCC
GAGGATGCCAAACTGCAGCTGAGCAAGGACACCTACGACGACGACCTGGA
CAACTGCTGGCCAGATCGGCGACCGAGTACGCCACCTGTTCTGGCCG
CCAAGAACCTGTCGACGCCATCTGCTGAGCGACATCTGAGAGTGAAC
ACCGAGATCACCAAGGCCCCCTGAGCGCTCTATGATCAAGAGATACGA
CGAGACCACAGGACCTGACCTGCTGAAAGCTCTGCTGCGGCAGCAGC
TGCTGAGAAGTACAAGAGATTTTTCTTCGACAGAGCAAGAACGGCTAC
GCCGGCTACATTGACGGCGGAGCCAGCCAGGAAGAGTCTTACAAGTTCAT
CAAGCCATCTGGAAAAGATGGACGGCACCGGAGAACTGCTGCTGAAGC
TGAAACAGAGAGGACCTGCTGCGGAAGCAGCGGACCTTCGACAACGGCAGC
ATCCCCACCAGATCCACCTGGGAGAGCTGCAGCCATTCTGGCGGGCA
GGAAGATTTTTACCATCTCTGAAGGACAACCGGAAAAGATCGAGAAGA

- continued

TCCTGACCTTCCGCATCCCCTACTACGTGGGCCCTTGCCAGGGGAAAC
AGCAGATTCGCCTGGATGACCAGAAAGAGCGAGGAAACATCACCCCCTG
GAACCTTCAGGAAAGTGGTGGACAAGGGCGCTTCCGCCAGAGCTTCATCG
AGCGGATGACCAACTTCGATAAGAACCAGCCCAACGAGAAGTGTGCC
AAGCACAGCTGTGTACGAGTACTTCACCGTGTATAACGAGCTGACCAA
AGTGAAATACGTGACCGAGGGAATGAGAAAGCCCGCTTCTGTAGCGGCG
AGCAGAAAAGGCCATCGTGGACTGTGTTCAAGACCAACCGGAAAGTG
ACCGTGAAGCAGCTGAAAGAGGACTACTTCAAGAAAATCGAGTGTTCGA
CTCCGTGGAATCTCCGCGTGGAAAGATCGGTTCAACGCTCCCTGGGCA
CATAACAGATCTGTGAAAATTATCAAGGACAAGGACTTCTGGACAAT
GAGGAAAACGAGGACATTCGGAAGATATCGTGTGACCCGACACTGTT
TGAGGACAGAGAGATGATCGAGGAACGGCTGAAAACCTATGCCACCTGT
TCGACGACAAAGTGTGAAAGCAGCTGAAAGCGCGGAGATACACCGCTGG
GGCAGGCTGAGCCGGAAGCTGATCAACGGCATCCGGGACAAGCAGTCCGG
CAAGACAATCTGGATTTCTGAACTCCGACGGCTTCGCCAACAGAACT
TCATGAGCTGATCCACGACGACAGCCTGACCTTTAAAGAGGACATCCAG
AAAGCCCAGGTGTCCGGCCAGGGCGATAGCCTGCACGAGCACATTGCCAA
TCTGGCCGCGACGCCCGCCATTAAGAAGGGCATCTGCACGACAGTGAAGG
TGGTGGACGAGCTCGTGAAGTGTGGCCCGGCAACAAGCCCGAGAACATC
GTGATCGAAATGGCCAGAGAGAACCAGACCACCCAGAAGGGACAGAAGAA
CAGCCGCGAGAGAATGAAGCGGATCGAAGAGGGCATCAAAGAGCTGGGCA
GCCAGATCTGAAAGAACACCCCGTGGAAAACACCCAGCTGCAGAACGAG
AAGCTGTACCTGTACTACCTGCAGAAATGGGCGGGATATGTACGTGGACCA
GGAAGTGGACATCAACCGCTGTCCGACTACGATGTGGACATATCGTGC
CTCAGAGCTTTCTGAAGGACGACTCCATCGACAACAAGTGTGACCCAGA
AGCGACAAGAACCGGGCAAGAGCGACAACGTGCCCTCCGAAGAGGTGCT
GAAGAAGATGAAGAACTACTGGCGGCGAGTGTGAAACGCCAAGCTGATTA
CCCAGAGAAAGTTTCGACAATCTGACCAAGGCCGAGAGAGGCGCCTGAGC
GAACTGGATAAGGCCGGCTTCATCAAGAGACAGCTGGTGGAAACCCGGCA
GATCACAAGACAGTGGCAGATCTGACTCCCGATGAACACTAAGT
ACGACGAGAATGACAAGCTGATCCGGGAAGTGAAGTGTACCCCTGAAG
TCCAAGCTGGTGTCCGATTTCCGGAAGGATTTCCAGTTTTACAAAGTGGC
CGAGATCAACAACCTACCACCGCCACGACGCTTACCTGAACGCGCTG
TGGGAACCCGCTGATCAAAAAGTACCCTAAGCTGGAAGAGGAGTTCGTG
TACGGCGACTACAAGGTGTACGAGTGCAGGAAAGTGTGCGCAAGAGCGA
GCAGGAAATCGGCAAGGCTACCGCAAGTACTTCTTCTACAGCAACATCA
TGAACTTTTTCAAGACCGAGATTACCTTGGCCAACGCGGAGATCCGGAAG
CGGCTCTGATCGAGACAAACGGGAAACCGGGGAGATCGTGTGGGATAA
GGCCCGGATTTTCCACCGTGCAGAAAGTGTGAGCATGCCCAAGTGA

- continued

ATATCGTGAAAAGACCGAGGTGCAGACAGCGGCTTCAGCAAAGAGTCT
ATCTGCCCAAGAGGAACAGCGATAAGCTGATCGCCAGAAAGAGGACTG
GGACCTTAAGAAGTACGGCGGCTTCGACAGCCCCACCGTGGCTATTCTG
TGCTGGTGGTGGCCAAAGTGGAAAAGGGCAAGTCCAAGAAAAGTGAAGAGT
GTGAAAGAGCTGTGGGGATCACCATCATGGAAAAGAGCAGCTTCGAGAA
GAATCCCATCGACTTCTGGAAGCCAAGGGCTACAAAGAAGTGA AAAAGG
ACCTGATCATCAAGCTGCCTAAGTACTCCCTGTTTCGAGCTGAAAACGGC
CGGAAGAGAATGCTGGCCTCTGCCGGGAACTGCAGAAGGGAAACGAACT
GGCCCTGCCCTCCAATATGTGAACTTCTGTACTGGCCAGCCACTATG
AGAAGCTGAAGGGCTCCCCCGAGGATAATGAGCAGAAAACAGCTGTTTGTG
GAACAGCACAAGCACTACCTGGACGAGATCATCGAGCAGATCAGCGAGTT
CTCCAAGAGAGTGTCTGGCCGACGCTAATCTGGACAAGTGTGTCCG
CCTACAACAAGCACCGGGATAAGCCCATCAGAGAGCAGCCGAGAAATATC
ATCCACCTGTTTACCCTGACCAATCTGGGAGCCCTGCCGCTTCAAGTA
CTTTGACACCACCATCGACCGGAAGAGGTACACCAGCACC AAAGAGGTGC
TGGACGCCACCTGATCCACCAGAGCATCACCGGCTGTACGAGACCGG
ATCGACCTGTCTCAGCTGGGAGGCGACAGCCC AAGAAGAAGAGAAAGGT
GGAGGCCAGCTAACATATGATTCGAATGTCTTTCTTGGCTATGACACTT
CCAGCAAAGGTAGGGCGGGCTGCAGAGCGGCTTCCCGGCTGCATGCA
ACACCGATGATGCTTCGACCCCCGAAGCTCCTTCGGGGCTGCATGGGCG
CTCCGATGCCGCTCCAGGGCGAGCGCTGTTTAAATAGCCAGCCCCCGAT
TGCAAAGACATTATAGCGAGCTACCAAAGCCATATTCAAACACCTAGATC
ACTACCCTTCTACACAGGCCACTCGAGCTTGTGATCGCACTCCGCTAAG
GGGGCGCTCTTCTCTTCTGTTTCAGTCAACCCGCAACATGACACAA
GAATCCCTGTTACTTCTCGACCGTATTGATTCCGATGATTCCTACGCGAG
CCTGCGGAACGACCAGGAATCTGGGAGGTGAGTGCAGAGCAAGCCCGG
CGGATCAGCGAGCGTGTTCAGATTGACTTGC AACCCCGCATTGTGT
CGACGAAGGCTTTTGGCTCTGTGCTGTCTCAAGCAGCATCTAACC
TGCGTCCGCTTTCCATTTGACGCGCTGGCCCGCCGAGCCCTGGAGGAG
CTCGGGCTGCCGGTCCCGCGGTGTGCGGGTGC CCGGCGAGAGCACAA
CCCCGTACTGGTCCGCGAGCCCGCCGGTGTCAAGCTGTTCCGCGAGC
ACTGGTGCCTCCGGAGAGCTCGCGTCCGAGTCCGAGGGCTACGCGGTC
CTGGCGGACGCCCCGGTCCCGGTGCCCGCTCTTCGGCCGCGGCGAGCT
GCGGCCCGGACCGGAGCTTGGCGTGGCCCTACCTGGTGTGAGCCGGA
TGACCGGACACCCTGGCGGTCCGCGATGGACGGCACGACCGACCGGAAC
GCGCTGCTCGCCCTGGCCCGGAACTCGGCCGGTGTCTGGCCGGCTGCA
CAGGTGCGCTGACCGGAAACCGTGTCTACCCCCATTCCGAGGTCT
TCCCGAACTGCTGCGGAAACCGCGCGGCGACCGTCCGAGACCACCGC
GGTGGGGTACTCTCGCCCGGTGTGAGCCGCTGGAGGACTGGCT

-continued

GCCGGACGTGGACACGCTGCTGGCCGGCCGGAACCCGGTTCGTCCACG
 GCGACCTGCACGGGACCAACATCTTCGTGGACCTGGCCGCGACCGAGGTC
 ACCGGGATCGTCGACTTACCAGCAGCTCTATGCGGGAGACTCCCGCTACAG
 CCTGGTGAACCTGCATCTCAACGCCTTCCGGGGCGACCGCGAGATCCTGG
 CCGCGCTGCTCGACGGGGCGCAGTGGAAAGCGGACCGAGGACTTCGCCCGC
 GAACTGCTCGCCTTACCTTCTGCACGACTTCGAGGTGTTCCGAGGAGAC
 CCGCTGGATCTCTCCGGCTTACCAGATCCGGAGGAACTGGCGCAGTTCC
 TCTGGGGGCCCGCGACACCGCCCCGGCGCCTGATAAGGATCCGGCAAG
 ACTGGCCCCGCTTGGCAACGCAACAGTGAAGCCCTCCCTAGTGTGTTTGG
 GGATGTGACTATGTATTTCGTGTGTTGGCCAAACGGGTCAACCCGAACAGAT
 TGATACCCGCCTTGGCATTCTCTGTGAGATGTAACGTGAGTGTGATGGTA
 CT

[0385] For all modified *Chlamydomonas reinhardtii* cells, Applicants used PCR, SURVEYOR nuclease assay, and DNA sequencing to verify successful modification.

Example 16: Use of Cas9 as a Transcriptional Repressor in Bacteria

[0386] The ability to artificially control transcription is essential both to the study of gene function and to the construction of synthetic gene networks with desired properties. Applicants describe here the use of the RNA-guided Cas9 protein as a programmable transcriptional repressor.

[0387] Applicants have previously demonstrated how the Cas9 protein of *Streptococcus pyogenes* SF370 can be used to direct genome editing in *Streptococcus pneumoniae*. In this study Applicants engineered the crR6Rk strain containing a minimal CRISPR system, consisting of cas9, the tracrRNA and a repeat. The D10A-H840 mutations were introduced into cas9 in this strain, giving strain crR6Rk**. Four spacers targeting different positions of the bgaA 3-galactosidase gene promoter were cloned in the CRISPR array carried by the previously described pDB98 plasmid. Applicants observed a X to Y fold reduction in P3-galactosidase activity depending on the targeted position, demonstrating the potential of Cas9 as a programmable repressor (FIG. 73).

[0388] To achieve Cas9** repression in *Escherichia coli* a green fluorescence protein (GFP) reporter plasmid (pDB127) was constructed to express the gfpmut2 gene from a constitutive promoter. The promoter was designed to carry several NPP PAMs on both strands, to measure the effect of Cas9** binding at various positions. Applicants introduced the D10A-H840 mutations into pCas9, a plasmid described carrying the tracrRNA, cas9 and a minimal CRISPR array designed for the easy cloning of new spacers. Twenty-two different spacers were designed to target different regions of the gfpmut2 promoter and open reading frame. An approximately 20-fold reduction of fluorescence of was observed upon targeting regions overlapping or adjacent to the -35 and -10 promoter elements and to the Shine-Dalgarno sequence. Targets on both strands showed similar repression levels. These results suggest that the binding of Cas9** to any position of the promoter region prevents transcription initiation, presumably through steric inhibition of RNAP binding.

[0389] To determine whether Cas9** could prevent transcription elongation, Applicants directed it to the reading frame of gfpmut2. A reduction in fluorescence was observed both when the coding and non-coding strands were targeted, suggesting that Cas9 binding is actually strong enough to represent an obstacle to the running RNAP. However, while a 40% reduction in expression was observed when the coding strand was the target, a 20-fold reduction was observed for the non-coding strand (FIG. 21b, compare T9, T10 and T11 to B9, B10 and B11). To directly determine the effects of Cas9** binding on transcription, Applicants extracted RNA from strains carrying either the T5, T10, B10 or a control construct that does not target pDB 127 and subjected it to Northern blot analysis using either a probe binding before (B477) or after (B510) the B10 and T10 target sites. Consistent with Applicants' fluorescence methods, no gfpmut2 transcription was detected when Cas9** was directed to the promoter region (T5 target) and a transcription was observed after the targeting of the T10 region. Interestingly, a smaller transcript was observed with the B477 probe. This band corresponds to the expected size of a transcript that would be interrupted by Cas9**, and is a direct indication of a transcriptional termination caused by dgRNA::Cas9** binding to the coding strand. Surprisingly, Applicants detected no transcript when the non-coding strand was targeted (B10). Since Cas9** binding to the B10 region is unlikely to interfere with transcription initiation, this result suggests that the mRNA was degraded. DgRNA::Cas9 was shown to bind ssRNA in vitro. Applicants speculate that binding may trigger degradation of the mRNA by host nucleases. Indeed, ribosome stalling can induce cleavage on the translated mRNA in *E. coli*.

[0390] Some applications require a precise tuning gene expression rather than its complete repression. Applicants sought to achieve intermediate repression levels through the introduction of mismatches that will weaken the crRNA/target interactions. Applicants created a series of spacers based on the B1, T5 and B10 constructs with increasing numbers of mutations in the 5' end of the crRNA. Up to 8 mutations in B1 and T5 did not affect the repression level, and a progressive increased in fluorescence was observed for additional mutations.

[0391] The observed repression with only an 8 nt match between the crRNA and its target raises the question of off-targeting effects of the use of Cas9** as a transcriptional regulator. Since a good PAM (NGG) is also required for Cas9 binding, the number of nucleotides to match to obtain some level of repression is 10. A 10 nt match occurs randomly once every ~1 Mbp, and such sites are thus likely to be found even in small bacterial genomes. However, to effectively repress transcription, such site needs to be in the promoter region of gene, which makes off-targeting much less likely. Applicants also showed that gene expression can be affected if the non-coding strand of a gene is targeted. For this to happen, a random target would have to be in the right orientation, but such events relatively more likely to happen. As a matter of fact, during the course of this study Applicants were unable to construct one of the designed spacer on pCas9**. Applicants later found this spacer showed a 12 bp match next to a good PAM in the essential murC gene. Such off-targeting could easily be avoided by a systematic blast of the designed spacers.

[0392] Aspects of the invention are further described in the following numbered paragraphs:

[0393] 1. A vector system comprising one or more vectors, wherein the system comprises

[0394] a. a first regulatory element operably linked to a traer mate sequence and one or more insertion sites for inserting a guide sequence upstream of the traer mate sequence, wherein when expressed, the guide sequence directs sequence-specific binding of a CRISPR complex to a target sequence in a eukaryotic cell, wherein the CRISPR complex comprises a CRISPR enzyme complexed with (1) the guide sequence that is hybridized to the target sequence, and (2) the traer mate sequence that is hybridized to the traer sequence; and

[0395] b. a second regulatory element operably linked to an enzyme-coding sequence encoding said CRISPR enzyme comprising a nuclear localization sequence; wherein components (a) and (b) are located on the same or different vectors of the system.

[0396] 2. The vector system of paragraph 1, wherein component (a) further comprises the traer sequence downstream of the traer mate sequence under the control of the first regulatory element.

[0397] 3. The vector system of paragraph 1, wherein component (a) further comprises two or more guide sequences operably linked to the first regulatory element, wherein when expressed, each of the two or more guide sequences direct sequence specific binding of a CRISPR complex to a different target sequence in a eukaryotic cell.

[0398] 4. The vector system of paragraph 1, wherein the system comprises the traer sequence under the control of a third regulatory element.

[0399] 5. The vector system of paragraph 1, wherein the traer sequence exhibits at least 50% of sequence complementarity along the length of the traer mate sequence when optimally aligned.

[0400] 6. The vector system of paragraph 1, wherein the CRISPR enzyme comprises one or more nuclear localization sequences of sufficient strength to drive accumulation of said CRISPR enzyme in a detectable amount in the nucleus of a eukaryotic cell.

[0401] 7. The vector system of paragraph 1, wherein the CRISPR enzyme is a type II CRISPR system enzyme.

[0402] 8. The vector system of paragraph 1, wherein the CRISPR enzyme is a Cas9 enzyme.

[0403] 9. The vector system of paragraph 1, wherein the CRISPR enzyme is codon-optimized for expression in a eukaryotic cell.

[0404] 10. The vector system of paragraph 1, wherein the CRISPR enzyme directs cleavage of one or two strands at the location of the target sequence.

[0405] 11. The vector system of paragraph 1, wherein the CRISPR enzyme lacks DNA strand cleavage activity.

[0406] 12. The vector system of paragraph 1, wherein the first regulatory element is a polymerase III promoter.

[0407] 13. The vector system of paragraph 1, wherein the second regulatory element is a polymerase II promoter.

[0408] 14. The vector system of paragraph 4, wherein the third regulatory element is a polymerase III promoter.

[0409] 15. The vector system of paragraph 1, wherein the guide sequence is at least 15 nucleotides in length.

[0410] 16. The vector system of paragraph 1, wherein fewer than 50% of the nucleotides of the guide sequence participate in self-complementary base-pairing when optimally folded.

[0411] 17. A vector comprising a regulatory element operably linked to an enzyme-coding sequence encoding a CRISPR enzyme comprising one or more nuclear localization sequences, wherein said regulatory element drives transcription of the CRISPR enzyme in a eukaryotic cell such that said CRISPR enzyme accumulates in a detectable amount in the nucleus of the eukaryotic cell.

[0412] 18. The vector of paragraph 17, wherein said regulatory element is a polymerase II promoter.

[0413] 19. The vector of paragraph 17, wherein said CRISPR enzyme is a type IICRISPR system enzyme.

[0414] 20. The vector of paragraph 17, wherein said CRISPR enzyme is a Cas9 enzyme.

[0415] 21. The vector of paragraph 17, wherein said CRISPR enzyme lacks the ability to cleave one or more strands of a target sequence to which it binds.

[0416] 22. A CRISPR enzyme comprising one or more nuclear localization sequences of sufficient strength to drive accumulation of said CRISPR enzyme in a detectable amount in the nucleus of a eukaryotic cell.

[0417] 23. The CRISPR enzyme of paragraph 22, wherein said CRISPR enzyme is a type IICRISPR system enzyme.

[0418] 24. The CRISPR enzyme of paragraph 22, wherein said CRISPR enzyme is a Cas9 enzyme.

[0419] 25. The CRISPR enzyme of paragraph 22, wherein said CRISPR enzyme lacks the ability to cleave one or more strands of a target sequence to which it binds.

[0420] 26. A eukaryotic host cell comprising:

[0421] a. a first regulatory element operably linked to a traer mate sequence and one or more insertion sites for inserting a guide sequence upstream of the traer mate sequence, wherein when expressed, the guide sequence directs sequence-specific binding of a CRISPR complex to a target sequence in a eukaryotic cell, wherein the CRISPR complex comprises a CRISPR enzyme complexed with (1) the guide sequence that is hybridized to the target sequence, and (2) the traer mate sequence that is hybridized to the traer sequence; and/or

[0422] b. a second regulatory element operably linked to an enzyme-coding sequence encoding said CRISPR enzyme comprising a nuclear localization sequence.

[0423] 27. The eukaryotic host cell of paragraph 26, wherein said host cell comprises components (a) and (b).

[0424] 28. The eukaryotic host cell of paragraph 26, wherein component (a), component (b), or components (a) and (b) are stably integrated into a genome of the host eukaryotic cell.

[0425] 29. The eukaryotic host cell of paragraph 26, wherein component (a) further comprises the traer sequence downstream of the traer mate sequence under the control of the first regulatory element.

[0426] 30. The eukaryotic host cell of paragraph 26, wherein component (a) further comprises two or more guide sequences operably linked to the first regulatory element, wherein when expressed, each of the two or more guide sequences direct sequence specific binding of a CRISPR complex to a different target sequence in a eukaryotic cell.

[0427] 31. The eukaryotic host cell of paragraph 26, further comprising a third regulatory element operably linked to said traer sequence.

- [0428] 32. The eukaryotic host cell of paragraph 26, wherein the traer sequence exhibits at least 50% of sequence complementarity along the length of the traer mate sequence when optimally aligned.
- [0429] 33. The eukaryotic host cell of paragraph 26, wherein the CRISPR enzyme comprises one or more nuclear localization sequences of sufficient strength to drive accumulation of said CRISPR enzyme in a detectable mount in the nucleus of a eukaryotic cell.
- [0430] 34. The eukaryotic host cell of paragraph 26, wherein the CRISPR enzyme is a type II CRISPR system enzyme.
- [0431] 35. The eukaryotic host cell of paragraph 26, wherein the CRISPR enzyme is a Cas9 enzyme.
- [0432] 36. The eukaryotic host cell of paragraph 26, wherein the CRISPR enzyme is codon-optimized for expression in a eukaryotic cell.
- [0433] 37. The eukaryotic host cell of paragraph 26, wherein the CRISPR enzyme directs cleavage of one or two strands at the location of the target sequence.
- [0434] 38. The eukaryotic host cell of paragraph 26, wherein the CRISPR enzyme lacks DNA strand cleavage activity.
- [0435] 39. The eukaryotic host cell of paragraph 26, wherein the first regulatory element is a polymerase III promoter.
- [0436] 40. The eukaryotic host cell of paragraph 26, wherein the second regulatory element is a polymerase II promoter.
- [0437] 41. The eukaryotic host cell of paragraph 31, wherein the third regulatory element is a polymerase III promoter.
- [0438] 42. The eukaryotic host cell of paragraph 26, wherein the guide sequence is at least 15 nucleotides in length.
- [0439] 43. The eukaryotic host cell of paragraph 26, wherein fewer than 50% of the nucleotides of the guide sequence participate in self-complementary base-pairing when optimally folded.
- [0440] 44. A non-human animal comprising a eukaryotic host cell of any one of paragraphs 26-43.
- [0441] 45. A kit comprising a vector system and instructions for using said kit, the vector system comprising:
- [0442] a. a first regulatory element operably linked to a traer mate sequence and one or more insertion sites for inserting a guide sequence upstream of the traer mate sequence, wherein when expressed, the guide sequence directs sequence-specific binding of a CRISPR complex to a target sequence in a eukaryotic cell, wherein the CRISPR complex comprises a CRISPR enzyme complexed with (1) the guide sequence that is hybridized to the target sequence, and (2) the traer mate sequence that is hybridized to the traer sequence; and/or
- [0443] b. a second regulatory element operably linked to an enzyme-coding sequence encoding said CRISPR enzyme comprising a nuclear localization sequence.
- [0444] 46. The kit of paragraph 45, wherein said kit comprises components (a) and (b) located on the same or different vectors of the system.
- [0445] 47. The kit of paragraph 45, wherein component (a) further comprises the traer sequence downstream of the traer mate sequence under the control of the first regulatory element.
- [0446] 48. The kit of paragraph 45, wherein component (a) further comprises two or more guide sequences operably linked to the first regulatory element, wherein when expressed, each of the two or more guide sequences direct sequence specific binding of a CRISPR complex to a different target sequence in a eukaryotic cell.
- [0447] 49. The kit of paragraph 45, wherein the system comprises the traer sequence under the control of a third regulatory element.
- [0448] 50. The kit of paragraph 45, wherein the traer sequence exhibits at least 50% of sequence complementarity along the length of the traer mate sequence when optimally aligned.
- [0449] 51. The kit of paragraph 45, wherein the CRISPR enzyme comprises one or more nuclear localization sequences of sufficient strength to drive accumulation of said CRISPR enzyme in a detectable mount in the nucleus of a eukaryotic cell.
- [0450] 52. The kit of paragraph 45, wherein the CRISPR enzyme is a type II CRISPR system enzyme.
- [0451] 53. The kit of paragraph 45, wherein the CRISPR enzyme is a Cas9 enzyme.
- [0452] 54. The kit of paragraph 45, wherein the CRISPR enzyme is codon-optimized for expression in a eukaryotic cell.
- [0453] 55. The kit of paragraph 45, wherein the CRISPR enzyme directs cleavage of one or two strands at the location of the target sequence.
- [0454] 56. The kit of paragraph 45, wherein the CRISPR enzyme lacks DNA strand cleavage activity.
- [0455] 57. The kit of paragraph 45, wherein the first regulatory element is a polymerase III promoter.
- [0456] 58. The kit of paragraph 45, wherein the second regulatory element is a polymerase II promoter.
- [0457] 59. The kit of paragraph 49, wherein the third regulatory element is a polymerase III promoter.
- [0458] 60. The kit of paragraph 45, wherein the guide sequence is at least 15 nucleotides in length.
- [0459] 61. The kit of paragraph 45, wherein fewer than 50% of the nucleotides of the guide sequence participate in self-complementary base-pairing when optimally folded.
- [0460] 62. A computer system for selecting a candidate target sequence within a nucleic acid sequence in a eukaryotic cell for targeting by a CRISPR complex, the system comprising:
- [0461] a. a memory unit configured to receive and/or store said nucleic acid sequence; and
- [0462] b. one or more processors alone or in combination programmed to (i) locate a CRISPR motif sequence within said nucleic acid sequence, and (ii) select a sequence adjacent to said located CRISPR motif sequence as the candidate target sequence to which the CRISPR complex binds.
- [0463] 63. The computer system of paragraph 62, wherein said locating step comprises identifying a CRISPR motif sequence located less than about 500 nucleotides away from said target sequence.
- [0464] 64. The computer system of paragraph 62, wherein said candidate target sequence is at least 10 nucleotides in length.
- [0465] 65. The computer system of paragraph 62, wherein the nucleotide at the 3' end of the candidate target sequence is located no more than about 10 nucleotides upstream of the CRISPR motif sequence.

[0466] 66. The computer system of paragraph 62, wherein the nucleic acid sequence in the eukaryotic cell is endogenous to the eukaryotic genome.

[0467] 67. The computer system of claim 62, wherein the nucleic acid sequence in the eukaryotic cell is exogenous to the eukaryotic genome.

[0468] 68. A computer-readable medium comprising codes that, upon execution by one or more processors, implements a method of selecting a candidate target sequence within a nucleic acid sequence in a eukaryotic cell for targeting by a CRISPR complex, said method comprising: (a) locating a CRISPR motif sequence within said nucleic acid sequence, and (b) selecting a sequence adjacent to said located CRISPR motif sequence as the candidate target sequence to which the CRISPR complex binds.

[0469] 69. The computer-readable medium of paragraph 68, wherein said locating comprises locating a CRISPR motif sequence that is less than about 500 nucleotides away from said target sequence.

[0470] 70. The computer-readable of paragraph 68, wherein said candidate target sequence is at least 10 nucleotides in length.

[0471] 71. The computer-readable of paragraph 68, wherein the nucleotide at the 3' end of the candidate target sequence is located no more than about 10 nucleotides upstream of the CRISPR motif sequence.

[0472] 72. The computer-readable of paragraph 68, wherein the nucleic acid sequence in the eukaryotic cell is endogenous to the eukaryotic genome.

[0473] 73. The computer-readable of paragraph 68, wherein the nucleic acid sequence in the eukaryotic cell is exogenous to the eukaryotic genome.

[0474] 74. A method of modifying a target polynucleotide in a eukaryotic cell, the method comprising allowing a CRISPR complex to bind to the target polynucleotide to effect cleavage of said target polynucleotide thereby modifying the target polynucleotide, wherein the CRISPR complex comprises a CRISPR enzyme complexed with a guide sequence hybridized to a target sequence within said target polynucleotide, wherein said guide sequence is linked to a traer mate sequence which in turn hybridizes to a traer sequence.

[0475] 75. The method of paragraph 74, wherein said cleavage comprises cleaving one or two strands at the location of the target sequence by said CRISPR enzyme.

[0476] 76. The method of paragraph 74, wherein said cleavage results in decreased transcription of a target gene.

[0477] 77. The method of paragraph 74, further comprising repairing said cleaved target polynucleotide by homologous recombination with an exogenous template polynucleotide, wherein said repair results in a mutation comprising an insertion, deletion, or substitution of one or more nucleotides of said target polynucleotide.

[0478] 78. The method of paragraph 77, wherein said mutation results in one or more amino acid changes in a protein expressed from a gene comprising the target sequence.

[0479] 79. The method of paragraph 74, further comprising delivering one or more vectors to said eukaryotic cell, wherein the one or more vectors drive expression of one or more of: the CRISPR enzyme, the guide sequence linked to the traer mate sequence, and the traer sequence.

[0480] 80. The method of paragraph 79, wherein said vectors are delivered to the eukaryotic cell in a subject.

[0481] 81. The method of paragraph 74, wherein said modifying takes place in said eukaryotic cell in a cell culture.

[0482] 82. The method of paragraph 74, further comprising isolating said eukaryotic cell from a subject prior to said modifying.

[0483] 83. The method of paragraph 82, further comprising returning said eukaryotic cell and/or cells derived therefrom to said subject.

[0484] 84. A method of modifying expression of a polynucleotide in a eukaryotic cell, the method comprising: allowing a CRISPR complex to bind to the polynucleotide such that said binding results in increased or decreased expression of said polynucleotide; wherein the CRISPR complex comprises a CRISPR enzyme complexed with a guide sequence hybridized to a target sequence within said polynucleotide, wherein said guide sequence is linked to a traer mate sequence which in turn hybridizes to a traer sequence.

[0485] 85. The method of paragraph 74, further comprising delivering one or more vectors to said eukaryotic cells, wherein the one or more vectors drive expression of one or more of: the CRISPR enzyme, the guide sequence linked to the traer mate sequence, and the traer sequence.

[0486] 86. A method of generating a model eukaryotic cell comprising a mutated disease gene, the method comprising:

[0487] a. introducing one or more vectors into a eukaryotic cell, wherein the one or more vectors drive expression of one or more of: a CRISPR enzyme, a guide sequence linked to a traer mate sequence, and a traer sequence; and [0488] b. allowing a CRISPR complex to bind to a target polynucleotide to effect cleavage of the target polynucleotide within said disease gene, wherein the CRISPR complex comprises the CRISPR enzyme complexed with (1) the guide sequence that is hybridized to the target sequence within the target polynucleotide, and (2) the traer mate sequence that is hybridized to the traer sequence, thereby generating a model eukaryotic cell comprising a mutated disease gene.

[0489] 87. The method of paragraph 86, wherein said cleavage comprises cleaving one or two strands at the location of the target sequence by said CRISPR enzyme.

[0490] 88. The method of paragraph 86, wherein said cleavage results in decreased transcription of a target gene.

[0491] 89. The method of paragraph 86, further comprising repairing said cleaved target polynucleotide by homologous recombination with an exogenous template polynucleotide, wherein said repair results in a mutation comprising an insertion, deletion, or substitution of one or more nucleotides of said target polynucleotide.

[0492] 90. The method of paragraph 89, wherein said mutation results in one or more amino acid changes in a protein expressed from a gene comprising the target sequence.

[0493] 91. A method of developing a biologically active agent that modulates a cell signaling event associated with a disease gene, comprising:

[0494] a. contacting a test compound with a model cell of any one of paragraphs 86-90; and

[0495] b. detecting a change in a readout that is indicative of a reduction or an augmentation of a cell signaling event associated with said mutation in said disease gene, thereby developing said biologically active agent that modulates said cell signaling event associated with said disease gene.

[0496] 92. A recombinant polynucleotide comprising a guide sequence upstream of a traer mate sequence, wherein the guide sequence when expressed directs sequence-specific binding of a CRISPR complex to a corresponding target sequence present in a eukaryotic cell.

[0497] 93. The recombinant polynucleotide of paragraph 89, wherein the target sequence is a viral sequence present in a eukaryotic cell.

[0498] 94. The recombinant polynucleotide of paragraph 89, wherein the target sequence is a proto-oncogene or an oncogene.

[0499] While preferred embodiments of the present invention have been shown and described herein, it will be obvious to those skilled in the art that such embodiments are provided by way of example only. Numerous variations, changes, and substitutions will now occur to those skilled in the art without departing from the invention. It should be understood that various alternatives to the embodiments of the invention described herein may be employed in practicing the invention. It is intended that the following claims define the scope of the invention and that methods and structures within the scope of these claims and their equivalents be covered thereby.

REFERENCES

- [0500] 1. Urnov, F. D., Rebar, E. J., Holmes, M. C., Zhang, H. S. & Gregory, P. D. Genome editing with engineered zinc finger nucleases. *Nat. Rev. Genet.* 11, 636-646 (2010).
- [0501] 2. Bogdanove, A. J. & Voytas, D. F. TAL effectors: customizable proteins for DNA targeting. *Science* 333, 1843-1846 (2011).
- [0502] 3. Stoddard, B. L. Homing endonuclease structure and function. *Q. Rev. Biophys.* 38, 49-95 (2005).
- [0503] 4. Bae, T. & Schneewind, O. Allelic replacement in *Staphylococcus aureus* with inducible counter-selection. *Plasmid* 55, 58-63 (2006).
- [0504] 5. Sung, C. K., Li, H., Claverys, J. P. & Morrison, D. A. An rpsL cassette, janus, for gene replacement through negative selection in *Streptococcus pneumoniae*. *Appl. Environ. Microbiol.* 67, 5190-5196 (2001).
- [0505] 6. Sharan, S. K., Thomason, L. C., Kuznetsov, S. G. & Court, D. L. Recombineering: a homologous recombination-based method of genetic engineering. *Nat. Protoc.* 4, 206-223 (2009).
- [0506] 7. Jinek, M. et al. A programmable dual-RNA-guided DNA endonuclease in adaptive bacterial immunity. *Science* 337, 816-821 (2012).
- [0507] 8. Deveau, H., Garneau, J. E. & Moineau, S. CRISPR/Cas system and its role in phage-bacteria interactions. *Annu. Rev. Microbiol.* 64, 475-493 (2010).
- [0508] 9. Horvath, P. & Barrangou, R. CRISPR/Cas, the immune system of bacteria and archaea. *Science* 327, 167-170 (2010).
- [0509] 10. Terns, M. P. & Terns, R. M. CRISPR-based adaptive immune systems. *Curr. Opin. Microbiol.* 14, 321-327 (2011).
- [0510] 11. van der Oost, J., Jore, M. M., Westra, E. R., Lundgren, M. & Brouns, S. J. CRISPR-based adaptive and heritable immunity in prokaryotes. *Trends. Biochem. Sci.* 34, 401-407 (2009).
- [0511] 12. Brouns, S. J. et al. Small CRISPR RNAs guide antiviral defense in prokaryotes. *Science* 321, 960-964 (2008).
- [0512] 13. Carte, J., Wang, R., Li, H., Terns, R. M. & Terns, M. P. Cas6 is an endoribonuclease that generates guide RNAs for invader defense in prokaryotes. *Genes Dev.* 22, 3489-3496 (2008).
- [0513] 14. Deltcheva, E. et al. CRISPR RNA maturation by trans-encoded small RNA and host factor RNase III. *Nature* 471, 602-607 (2011).
- [0514] 15. Hatoum-Aslan, A., Maniv, I. & Marraffini, L. A. Mature clustered, regularly interspaced, short palindromic repeats RNA (crRNA) length is measured by a ruler mechanism anchored at the precursor processing site. *Proc. Natl. Acad. Sci. U.S.A.* 108, 21218-21222 (2011).
- [0515] 16. Haurwitz, R. E., Jinek, M., Wiedenheft, B., Zhou, K. & Doudna, J. A. Sequence- and structure-specific RNA processing by a CRISPR endonuclease. *Science* 329, 1355-1358 (2010).
- [0516] 17. Deveau, H. et al. Phage response to CRISPR-encoded resistance in *Streptococcus thermophilus*. *J. Bacteriol.* 190, 1390-1400 (2008).
- [0517] 18. Gasiunas, G., Barrangou, R., Horvath, P. & Siksnys, V. Cas9-crRNA ribonucleoprotein complex mediates specific DNA cleavage for adaptive immunity in bacteria. *Proc. Natl. Acad. Sci. U.S.A.* (2012).
- [0518] 19. Makarova, K. S., Aravind, L., Wolf, Y. I. & Koonin, E. V. Unification of Cas protein families and a simple scenario for the origin and evolution of CRISPR-Cas systems. *Biol. Direct.* 6, 38 (2011).
- [0519] 20. Barrangou, R. RNA-mediated programmable DNA cleavage. *Nat. Biotechnol.* 30, 836-838 (2012).
- [0520] 21. Brouns, S. J. Molecular biology. A Swiss army knife of immunity. *Science* 337, 808-809 (2012).
- [0521] 22. Carroll, D. A CRISPR Approach to Gene Targeting. *Mol. Ther.* 20, 1658-1660 (2012).
- [0522] 23. Bikard, D., Hatoum-Aslan, A., Mucida, D. & Marraffini, L. A. CRISPR interference can prevent natural transformation and virulence acquisition during in vivo bacterial infection. *Cell Host Microbe* 12, 177-186 (2012).
- [0523] 24. Sapranaukas, R. et al. The *Streptococcus thermophilus* CRISPR/Cas system provides immunity in *Escherichia coli*. *Nucleic Acids Res.* (2011).
- [0524] 25. Semenova, E. et al. Interference by clustered regularly interspaced short palindromic repeat (CRISPR) RNA is governed by a seed sequence. *Proc. Natl. Acad. Sci. U.S.A.* (2011).
- [0525] 26. Wiedenheft, B. et al. RNA-guided complex from a bacterial immune system enhances target recognition through seed sequence interactions. *Proc. Natl. Acad. Sci. U.S.A.* (2011).
- [0526] 27. Zahner, D. & Hakenbeck, R. The *Streptococcus pneumoniae* beta-galactosidase is a surface protein. *J. Bacteriol.* 182, 5919-5921 (2000).
- [0527] 28. Marraffini, L. A., Dedent, A. C. & Schneewind, O. Sortases and the art of anchoring proteins to the envelopes of gram-positive bacteria. *Microbiol. Mol. Biol. Rev.* 70, 192-221 (2006).
- [0528] 29. Motamedi, M. R., Szigety, S. K. & Rosenberg, S. M. Double-strand-break repair recombination in *Escherichia coli*: physical evidence for a DNA replication mechanism in vivo. *Genes Dev.* 13, 2889-2903 (1999).
- [0529] 30. Hosaka, T. et al. The novel mutation K87E in ribosomal protein S12 enhances protein synthesis activity

- during the late growth phase in *Escherichia coli*. *Mol. Genet. Genomics* 271, 317-324 (2004).
- [0530] 31. Costantino, N. & Court, D. L. Enhanced levels of lambda Red-mediated recombinants in mismatch repair mutants. *Proc. Natl. Acad. Sci. U.S.A.* 100, 15748-15753 (2003).
- [0531] 32. Edgar, R. & Qimron, U. The *Escherichia coli* CRISPR system protects from lambda lysogenization, lysogens, and prophage induction. *J. Bacteriol.* 192, 6291-6294 (2010).
- [0532] 33. Marraffini, L. A. & Sontheimer, E. J. Self versus non-self discrimination during CRISPR RNA-directed immunity. *Nature* 463, 568-571 (2010).
- [0533] 34. Fischer, S. et al. An archaeal immune system can detect multiple Protospacer Adjacent Motifs (PAMs) to target invader DNA. *J. Biol. Chem.* 287, 33351-33363 (2012).
- [0534] 35. Gudbergdottir, S. et al. Dynamic properties of the *Sulfolobus* CRISPR/Cas and CRISPR/Cmr systems when challenged with vector-borne viral and plasmid genes and protospacers. *Mol. Microbiol.* 79, 35-49 (2011).
- [0535] 36. Wang, H. H. et al. Genome-scale promoter engineering by coselection MAGE. *Nat Methods* 9, 591-593 (2012).
- [0536] 37. Cong, L. et al. Multiplex Genome Engineering Using CRISPR/Cas Systems. *Science* In press (2013).
- [0537] 38. Mali, P. et al. RNA-Guided Human Genome Engineering via Cas9. *Science* In press (2013).
- [0538] 39. Hoskins, J. et al. Genome of the bacterium *Streptococcus pneumoniae* strain R6. *J. Bacteriol.* 183, 5709-5717 (2001).
- [0539] 40. Havarstein, L. S., Coomaraswamy, G. & Morrison, D. A. An unmodified heptadecapeptide pheromone induces competence for genetic transformation in *Streptococcus pneumoniae*. *Proc. Natl. Acad. Sci. U.S.A.* 92, 11140-11144 (1995).
- [0540] 41. Horinouchi, S. & Weisblum, B. Nucleotide sequence and functional map of pC194, a plasmid that specifies inducible chloramphenicol resistance. *J. Bacteriol.* 150, 815-825 (1982).
- [0541] 42. Horton, R. M. In Vitro Recombination and Mutagenesis of DNA: SOEing Together Tailor-Made Genes. *Methods Mol. Biol.* 15, 251-261 (1993).
- [0542] 43. Podbielski, A., Spellerberg, B., Woischnik, M., Pohl, B. & Luttmann, R. Novel series of plasmid vectors for gene inactivation and expression analysis in group A streptococci (GAS). *Gene* 177, 137-147 (1996).
- [0543] 44. Husmann, L. K., Scott, J. R., Lindahl, G. & Stenberg, L. Expression of the Arp protein, a member of the M protein family, is not sufficient to inhibit phagocytosis of *Streptococcus pyogenes*. *Infection and immunity* 63, 345-348 (1995).
- [0544] 45. Gibson, D. G. et al. Enzymatic assembly of DNA molecules up to several hundred kilobases. *Nat Methods* 6, 343-345 (2009).

SEQUENCE LISTING

<160> NUMBER OF SEQ ID NOS: 537

<210> SEQ ID NO 1
 <211> LENGTH: 7
 <212> TYPE: PRT
 <213> ORGANISM: Simian virus 40

<400> SEQUENCE: 1

Pro Lys Lys Lys Arg Lys Val
 1 5

<210> SEQ ID NO 2
 <211> LENGTH: 16
 <212> TYPE: PRT
 <213> ORGANISM: Unknown
 <220> FEATURE:
 <223> OTHER INFORMATION: Description of Unknown:
 Nucleoplasmin bipartite NLS sequence

<400> SEQUENCE: 2

Lys Arg Pro Ala Ala Thr Lys Lys Ala Gly Gln Ala Lys Lys Lys Lys
 1 5 10 15

<210> SEQ ID NO 3
 <211> LENGTH: 9
 <212> TYPE: PRT
 <213> ORGANISM: Unknown
 <220> FEATURE:
 <223> OTHER INFORMATION: Description of Unknown:
 C-myc NLS sequence

<400> SEQUENCE: 3

Pro Ala Ala Lys Arg Val Lys Leu Asp
 1 5

-continued

<210> SEQ ID NO 4
 <211> LENGTH: 11
 <212> TYPE: PRT
 <213> ORGANISM: Unknown
 <220> FEATURE:
 <223> OTHER INFORMATION: Description of Unknown:
 C-myc NLS sequence

<400> SEQUENCE: 4

Arg Gln Arg Arg Asn Glu Leu Lys Arg Ser Pro
 1 5 10

<210> SEQ ID NO 5
 <211> LENGTH: 38
 <212> TYPE: PRT
 <213> ORGANISM: Homo sapiens

<400> SEQUENCE: 5

Asn Gln Ser Ser Asn Phe Gly Pro Met Lys Gly Gly Asn Phe Gly Gly
 1 5 10 15

Arg Ser Ser Gly Pro Tyr Gly Gly Gly Gly Gln Tyr Phe Ala Lys Pro
 20 25 30

Arg Asn Gln Gly Gly Tyr
 35

<210> SEQ ID NO 6
 <211> LENGTH: 42
 <212> TYPE: PRT
 <213> ORGANISM: Unknown
 <220> FEATURE:
 <223> OTHER INFORMATION: Description of Unknown:
 IBB domain from importin-alpha sequence

<400> SEQUENCE: 6

Arg Met Arg Ile Glx Phe Lys Asn Lys Gly Lys Asp Thr Ala Glu Leu
 1 5 10 15

Arg Arg Arg Arg Val Glu Val Ser Val Glu Leu Arg Lys Ala Lys Lys
 20 25 30

Asp Glu Gln Ile Leu Lys Arg Arg Asn Val
 35 40

<210> SEQ ID NO 7
 <211> LENGTH: 8
 <212> TYPE: PRT
 <213> ORGANISM: Unknown
 <220> FEATURE:
 <223> OTHER INFORMATION: Description of Unknown:
 Myoma T protein sequence

<400> SEQUENCE: 7

Val Ser Arg Lys Arg Pro Arg Pro
 1 5

<210> SEQ ID NO 8
 <211> LENGTH: 8
 <212> TYPE: PRT
 <213> ORGANISM: Unknown
 <220> FEATURE:
 <223> OTHER INFORMATION: Description of Unknown:
 Myoma T protein sequence

<400> SEQUENCE: 8

-continued

Pro Pro Lys Lys Ala Arg Glu Asp
1 5

<210> SEQ ID NO 9
<211> LENGTH: 8
<212> TYPE: PRT
<213> ORGANISM: Homo sapiens

<400> SEQUENCE: 9

Pro Gln Pro Lys Lys Lys Pro Leu
1 5

<210> SEQ ID NO 10
<211> LENGTH: 12
<212> TYPE: PRT
<213> ORGANISM: Mus musculus

<400> SEQUENCE: 10

Ser Ala Leu Ile Lys Lys Lys Lys Lys Met Ala Pro
1 5 10

<210> SEQ ID NO 11
<211> LENGTH: 5
<212> TYPE: PRT
<213> ORGANISM: Influenza virus

<400> SEQUENCE: 11

Asp Arg Leu Arg Arg
1 5

<210> SEQ ID NO 12
<211> LENGTH: 7
<212> TYPE: PRT
<213> ORGANISM: Influenza virus

<400> SEQUENCE: 12

Pro Lys Gln Lys Lys Arg Lys
1 5

<210> SEQ ID NO 13
<211> LENGTH: 10
<212> TYPE: PRT
<213> ORGANISM: Hepatitis delta virus

<400> SEQUENCE: 13

Arg Lys Leu Lys Lys Lys Ile Lys Lys Leu
1 5 10

<210> SEQ ID NO 14
<211> LENGTH: 10
<212> TYPE: PRT
<213> ORGANISM: Mus musculus

<400> SEQUENCE: 14

Arg Glu Lys Lys Lys Phe Leu Lys Arg Arg
1 5 10

<210> SEQ ID NO 15
<211> LENGTH: 20
<212> TYPE: PRT
<213> ORGANISM: Homo sapiens

-continued

<400> SEQUENCE: 15

```

Lys Arg Lys Gly Asp Glu Val Asp Gly Val Asp Glu Val Ala Lys Lys
1          5              10              15
Lys Ser Lys Lys
                20

```

<210> SEQ ID NO 16
 <211> LENGTH: 17
 <212> TYPE: PRT
 <213> ORGANISM: Homo sapiens

<400> SEQUENCE: 16

```

Arg Lys Cys Leu Gln Ala Gly Met Asn Leu Glu Ala Arg Lys Thr Lys
1          5              10              15
Lys

```

<210> SEQ ID NO 17
 <211> LENGTH: 27
 <212> TYPE: DNA
 <213> ORGANISM: Artificial Sequence
 <220> FEATURE:
 <223> OTHER INFORMATION: Description of Artificial Sequence: Synthetic
 oligonucleotide
 <220> FEATURE:
 <221> NAME/KEY: modified_base
 <222> LOCATION: (1)..(20)
 <223> OTHER INFORMATION: a, c, t or g
 <220> FEATURE:
 <221> NAME/KEY: modified_base
 <222> LOCATION: (21)..(22)
 <223> OTHER INFORMATION: a, c, t, g, unknown or other

<400> SEQUENCE: 17

```

nnnnnnnnnn nnnnnnnnnn nnagaaw                27

```

<210> SEQ ID NO 18
 <211> LENGTH: 19
 <212> TYPE: DNA
 <213> ORGANISM: Artificial Sequence
 <220> FEATURE:
 <223> OTHER INFORMATION: Description of Artificial Sequence: Synthetic
 oligonucleotide
 <220> FEATURE:
 <221> NAME/KEY: modified_base
 <222> LOCATION: (1)..(12)
 <223> OTHER INFORMATION: a, c, t or g
 <220> FEATURE:
 <221> NAME/KEY: modified_base
 <222> LOCATION: (13)..(14)
 <223> OTHER INFORMATION: a, c, t, g, unknown or other

<400> SEQUENCE: 18

```

nnnnnnnnnn nnnnagaaw                19

```

<210> SEQ ID NO 19
 <211> LENGTH: 27
 <212> TYPE: DNA
 <213> ORGANISM: Artificial Sequence
 <220> FEATURE:
 <223> OTHER INFORMATION: Description of Artificial Sequence: Synthetic
 oligonucleotide
 <220> FEATURE:
 <221> NAME/KEY: modified_base
 <222> LOCATION: (1)..(20)
 <223> OTHER INFORMATION: a, c, t or g
 <220> FEATURE:

-continued

```

<221> NAME/KEY: modified_base
<222> LOCATION: (21)..(22)
<223> OTHER INFORMATION: a, c, t, g, unknown or other

<400> SEQUENCE: 19

nnnnnnnnnn nnnnnnnnnn nnagaaw                27

<210> SEQ ID NO 20
<211> LENGTH: 18
<212> TYPE: DNA
<213> ORGANISM: Artificial Sequence
<220> FEATURE:
<223> OTHER INFORMATION: Description of Artificial Sequence: Synthetic
oligonucleotide
<220> FEATURE:
<221> NAME/KEY: modified_base
<222> LOCATION: (1)..(11)
<223> OTHER INFORMATION: a, c, t or g
<220> FEATURE:
<221> NAME/KEY: modified_base
<222> LOCATION: (12)..(13)
<223> OTHER INFORMATION: a, c, t, g, unknown or other

<400> SEQUENCE: 20

nnnnnnnnnn nnnagaaw                18

<210> SEQ ID NO 21
<211> LENGTH: 137
<212> TYPE: DNA
<213> ORGANISM: Artificial Sequence
<220> FEATURE:
<223> OTHER INFORMATION: Description of Artificial Sequence: Synthetic
polynucleotide
<220> FEATURE:
<221> NAME/KEY: modified_base
<222> LOCATION: (1)..(20)
<223> OTHER INFORMATION: a, c, t, g, unknown or other

<400> SEQUENCE: 21

nnnnnnnnnn nnnnnnnnnn gttttgtac tctcaagatt tagaaataaa tcttgcagaa    60
gctacaaaga taaggcttca tgccgaaatc aacaccctgt cattttatgg cagggtgttt    120
tcggtattta atttttt                137

<210> SEQ ID NO 22
<211> LENGTH: 123
<212> TYPE: DNA
<213> ORGANISM: Artificial Sequence
<220> FEATURE:
<223> OTHER INFORMATION: Description of Artificial Sequence: Synthetic
polynucleotide
<220> FEATURE:
<221> NAME/KEY: modified_base
<222> LOCATION: (1)..(20)
<223> OTHER INFORMATION: a, c, t, g, unknown or other

<400> SEQUENCE: 22

nnnnnnnnnn nnnnnnnnnn gttttgtac tctcagaaat gcagaagcta caagataag    60
gcttcatgcc gaaatcaaca ccctgtcatt ttatggcagg gtgttttcgt tatttaattt    120
ttt                123

<210> SEQ ID NO 23
<211> LENGTH: 110
<212> TYPE: DNA
<213> ORGANISM: Artificial Sequence

```

-continued

```

<220> FEATURE:
<223> OTHER INFORMATION: Description of Artificial Sequence: Synthetic
      polynucleotide
<220> FEATURE:
<221> NAME/KEY: modified_base
<222> LOCATION: (1)..(20)
<223> OTHER INFORMATION: a, c, t, g, unknown or other

<400> SEQUENCE: 23

nnnnnnnnnn nnnnnnnnnn gttttgtac tctcagaaat gcagaagcta caaagataag      60
gtttcattgcc gaaatcaaca cctgtcatt ttatggcagg gtgttttttt      110

<210> SEQ ID NO 24
<211> LENGTH: 102
<212> TYPE: DNA
<213> ORGANISM: Artificial Sequence
<220> FEATURE:
<223> OTHER INFORMATION: Description of Artificial Sequence: Synthetic
      polynucleotide
<220> FEATURE:
<221> NAME/KEY: modified_base
<222> LOCATION: (1)..(20)
<223> OTHER INFORMATION: a, c, t, g, unknown or other

<400> SEQUENCE: 24

nnnnnnnnnn nnnnnnnnnn gtttttagagc tagaaatagc aagttaaaat aaggctagtc      60
cgttatcaac ttgaaaaagt ggcaccgagt cgggtctttt tt      102

<210> SEQ ID NO 25
<211> LENGTH: 88
<212> TYPE: DNA
<213> ORGANISM: Artificial Sequence
<220> FEATURE:
<223> OTHER INFORMATION: Description of Artificial Sequence: Synthetic
      oligonucleotide
<220> FEATURE:
<221> NAME/KEY: modified_base
<222> LOCATION: (1)..(20)
<223> OTHER INFORMATION: a, c, t, g, unknown or other

<400> SEQUENCE: 25

nnnnnnnnnn nnnnnnnnnn gtttttagagc tagaaatagc aagttaaaat aaggctagtc      60
cgttatcaac ttgaaaaagt gttttttt      88

<210> SEQ ID NO 26
<211> LENGTH: 76
<212> TYPE: DNA
<213> ORGANISM: Artificial Sequence
<220> FEATURE:
<223> OTHER INFORMATION: Description of Artificial Sequence: Synthetic
      oligonucleotide
<220> FEATURE:
<221> NAME/KEY: modified_base
<222> LOCATION: (1)..(20)
<223> OTHER INFORMATION: a, c, t, g, unknown or other

<400> SEQUENCE: 26

nnnnnnnnnn nnnnnnnnnn gtttttagagc tagaaatagc aagttaaaat aaggctagtc      60
cgttatcatt tttttt      76

<210> SEQ ID NO 27
<211> LENGTH: 12
<212> TYPE: DNA
<213> ORGANISM: Artificial Sequence

```

-continued

<220> FEATURE:
 <223> OTHER INFORMATION: Description of Artificial Sequence: Synthetic
 oligonucleotide

 <400> SEQUENCE: 27

 gtttttagagc ta 12

 <210> SEQ ID NO 28
 <211> LENGTH: 31
 <212> TYPE: DNA
 <213> ORGANISM: Artificial Sequence
 <220> FEATURE:
 <223> OTHER INFORMATION: Description of Artificial Sequence: Synthetic
 oligonucleotide

 <400> SEQUENCE: 28

 tagcaagtta aaataaggct agtccgtttt t 31

 <210> SEQ ID NO 29
 <211> LENGTH: 27
 <212> TYPE: DNA
 <213> ORGANISM: Artificial Sequence
 <220> FEATURE:
 <223> OTHER INFORMATION: Description of Artificial Sequence: Synthetic
 oligonucleotide
 <220> FEATURE:
 <221> NAME/KEY: modified_base
 <222> LOCATION: (1)..(22)
 <223> OTHER INFORMATION: a, c, t, g, unknown or other

 <400> SEQUENCE: 29

 nnnnnnnnnn nnnnnnnnnn nnagaaw 27

 <210> SEQ ID NO 30
 <211> LENGTH: 12
 <212> TYPE: RNA
 <213> ORGANISM: Artificial Sequence
 <220> FEATURE:
 <223> OTHER INFORMATION: Description of Artificial Sequence: Synthetic
 oligonucleotide

 <400> SEQUENCE: 30

 guuuuagagc ua 12

 <210> SEQ ID NO 31
 <211> LENGTH: 33
 <212> TYPE: DNA
 <213> ORGANISM: Homo sapiens

 <400> SEQUENCE: 31

 ggacatcgat gtcacctcca atgactaggg tgg 33

 <210> SEQ ID NO 32
 <211> LENGTH: 33
 <212> TYPE: DNA
 <213> ORGANISM: Homo sapiens

 <400> SEQUENCE: 32

 cattggaggt gacatcgatg tctctcccat tgg 33

 <210> SEQ ID NO 33
 <211> LENGTH: 33
 <212> TYPE: DNA
 <213> ORGANISM: Homo sapiens

-continued

<400> SEQUENCE: 33

ggaagggcct gagtccgagc agaagaagaa ggg 33

<210> SEQ ID NO 34

<211> LENGTH: 33

<212> TYPE: DNA

<213> ORGANISM: Homo sapiens

<400> SEQUENCE: 34

ggtggcgaga ggggccgaga ttgggtgttc agg 33

<210> SEQ ID NO 35

<211> LENGTH: 33

<212> TYPE: DNA

<213> ORGANISM: Homo sapiens

<400> SEQUENCE: 35

atgcaggagg gtggcgagag gggccgagat tgg 33

<210> SEQ ID NO 36

<211> LENGTH: 21

<212> TYPE: DNA

<213> ORGANISM: Artificial Sequence

<220> FEATURE:

<223> OTHER INFORMATION: Description of Artificial Sequence: Synthetic primer

<400> SEQUENCE: 36

aaaaccaccc ttctctctgg c 21

<210> SEQ ID NO 37

<211> LENGTH: 21

<212> TYPE: DNA

<213> ORGANISM: Artificial Sequence

<220> FEATURE:

<223> OTHER INFORMATION: Description of Artificial Sequence: Synthetic primer

<400> SEQUENCE: 37

ggagattgga gacacggaga g 21

<210> SEQ ID NO 38

<211> LENGTH: 20

<212> TYPE: DNA

<213> ORGANISM: Artificial Sequence

<220> FEATURE:

<223> OTHER INFORMATION: Description of Artificial Sequence: Synthetic primer

<400> SEQUENCE: 38

ctggaagcc aatgcctgac 20

<210> SEQ ID NO 39

<211> LENGTH: 20

<212> TYPE: DNA

<213> ORGANISM: Artificial Sequence

<220> FEATURE:

<223> OTHER INFORMATION: Description of Artificial Sequence: Synthetic primer

<400> SEQUENCE: 39

ggcagcaaac tccttgctc 20

-continued

<210> SEQ ID NO 40
<211> LENGTH: 335
<212> TYPE: DNA
<213> ORGANISM: Artificial Sequence
<220> FEATURE:
<223> OTHER INFORMATION: Description of Artificial Sequence: Synthetic polynucleotide

<400> SEQUENCE: 40

```
gagggcctat ttcccatgat tccttcatat ttgcatatac gatacaaggc tgtagagag    60
ataattggaa ttaatttgac tgtaaacaca aagatattag tacaaaatac gtgacgtaga    120
aagtaataat ttcttgggta gtttgcagtt ttaaaattat gttttaaata ggactatcat    180
atgcttacgc taacttgaaa gtatttcgat ttcttggcctt tatatatcct gtggaaagga    240
cgaaacaccg gaaccattca aaacagcata gcaagttaaa ataaggctag tccggtatca    300
acttgaaaaa gtggcacoga gtcggtgctt ttttt                                     335
```

<210> SEQ ID NO 41
<211> LENGTH: 423
<212> TYPE: DNA
<213> ORGANISM: Artificial Sequence
<220> FEATURE:
<223> OTHER INFORMATION: Description of Artificial Sequence: Synthetic polynucleotide

<400> SEQUENCE: 41

```
gagggcctat ttcccatgat tccttcatat ttgcatatac gatacaaggc tgtagagag    60
ataattggaa ttaatttgac tgtaaacaca aagatattag tacaaaatac gtgacgtaga    120
aagtaataat ttcttgggta gtttgcagtt ttaaaattat gttttaaata ggactatcat    180
atgcttacgc taacttgaaa gtatttcgat ttcttggcctt tatatatcct gtggaaagga    240
cgaaacaccg gtagtattaa gtattgtttt atggctgata aatttctttg aatttctcct    300
tgattatttg ttataaaagt tataaaataa tcttgttggg accattcaaa acagcatagc    360
aagttaaata aaggctagtc cgttatcaac ttgaaaaagt ggcaccgagt cggtgctttt    420
ttt                                     423
```

<210> SEQ ID NO 42
<211> LENGTH: 339
<212> TYPE: DNA
<213> ORGANISM: Artificial Sequence
<220> FEATURE:
<223> OTHER INFORMATION: Description of Artificial Sequence: Synthetic polynucleotide

<400> SEQUENCE: 42

```
gagggcctat ttcccatgat tccttcatat ttgcatatac gatacaaggc tgtagagag    60
ataattggaa ttaatttgac tgtaaacaca aagatattag tacaaaatac gtgacgtaga    120
aagtaataat ttcttgggta gtttgcagtt ttaaaattat gttttaaata ggactatcat    180
atgcttacgc taacttgaaa gtatttcgat ttcttggcctt tatatatcct gtggaaagga    240
cgaaacaccg ggttttagag ctatgctgtt ttgaatggtc ccaaaccggg tcttcgagaa    300
gacgttttag agctatgctg ttttgaatgg tcccaaac                                     339
```

<210> SEQ ID NO 43

-continued

```

<211> LENGTH: 309
<212> TYPE: DNA
<213> ORGANISM: Artificial Sequence
<220> FEATURE:
<223> OTHER INFORMATION: Description of Artificial Sequence: Synthetic
      polynucleotide

<400> SEQUENCE: 43

gagggcctat ttcccatgat tccttcatat ttgcatatac gatacaaggc tgtagagag      60
ataattggaa ttaatttgac tgtaaacaca aagatattag tacaaaaatac gtgacgtaga      120
aagtaataat ttcttgggta gtttgcagtt ttaaaattat gttttaaataa ggactatcat      180
atgcttacgc taacttgaaa gtatttcgat ttcttggcctt tatatatcctt gtggaaagga      240
cgaaacaccg ggtcttcgag aagacctggt ttagagctag aaatagcaag ttaaaataag      300
gctagtccg                                          309

<210> SEQ ID NO 44
<211> LENGTH: 1648
<212> TYPE: PRT
<213> ORGANISM: Artificial Sequence
<220> FEATURE:
<223> OTHER INFORMATION: Description of Artificial Sequence: Synthetic
      polypeptide

<400> SEQUENCE: 44

Met Asp Tyr Lys Asp His Asp Gly Asp Tyr Lys Asp His Asp Ile Asp
1          5          10          15
Tyr Lys Asp Asp Asp Asp Lys Met Ala Pro Lys Lys Lys Arg Lys Val
20         25         30
Gly Ile His Gly Val Pro Ala Ala Asp Lys Lys Tyr Ser Ile Gly Leu
35         40         45
Asp Ile Gly Thr Asn Ser Val Gly Trp Ala Val Ile Thr Asp Glu Tyr
50         55         60
Lys Val Pro Ser Lys Lys Phe Lys Val Leu Gly Asn Thr Asp Arg His
65         70         75         80
Ser Ile Lys Lys Asn Leu Ile Gly Ala Leu Leu Phe Asp Ser Gly Glu
85         90         95
Thr Ala Glu Ala Thr Arg Leu Lys Arg Thr Ala Arg Arg Arg Tyr Thr
100        105        110
Arg Arg Lys Asn Arg Ile Cys Tyr Leu Gln Glu Ile Phe Ser Asn Glu
115        120        125
Met Ala Lys Val Asp Asp Ser Phe Phe His Arg Leu Glu Glu Ser Phe
130        135        140
Leu Val Glu Glu Asp Lys Lys His Glu Arg His Pro Ile Phe Gly Asn
145        150        155        160
Ile Val Asp Glu Val Ala Tyr His Glu Lys Tyr Pro Thr Ile Tyr His
165        170        175
Leu Arg Lys Lys Leu Val Asp Ser Thr Asp Lys Ala Asp Leu Arg Leu
180        185        190
Ile Tyr Leu Ala Leu Ala His Met Ile Lys Phe Arg Gly His Phe Leu
195        200        205
Ile Glu Gly Asp Leu Asn Pro Asp Asn Ser Asp Val Asp Lys Leu Phe
210        215        220
Ile Gln Leu Val Gln Thr Tyr Asn Gln Leu Phe Glu Glu Asn Pro Ile
225        230        235        240

```

-continued

Lys Asp Lys Asp Phe Leu Asp Asn Glu Glu Asn Glu Asp Ile Leu Glu
 645 650 655
 Asp Ile Val Leu Thr Leu Thr Leu Phe Glu Asp Arg Glu Met Ile Glu
 660 665 670
 Glu Arg Leu Lys Thr Tyr Ala His Leu Phe Asp Asp Lys Val Met Lys
 675 680 685
 Gln Leu Lys Arg Arg Arg Tyr Thr Gly Trp Gly Arg Leu Ser Arg Lys
 690 695 700
 Leu Ile Asn Gly Ile Arg Asp Lys Gln Ser Gly Lys Thr Ile Leu Asp
 705 710 715 720
 Phe Leu Lys Ser Asp Gly Phe Ala Asn Arg Asn Phe Met Gln Leu Ile
 725 730 735
 His Asp Asp Ser Leu Thr Phe Lys Glu Asp Ile Gln Lys Ala Gln Val
 740 745 750
 Ser Gly Gln Gly Asp Ser Leu His Glu His Ile Ala Asn Leu Ala Gly
 755 760 765
 Ser Pro Ala Ile Lys Lys Gly Ile Leu Gln Thr Val Lys Val Val Asp
 770 775 780
 Glu Leu Val Lys Val Met Gly Arg His Lys Pro Glu Asn Ile Val Ile
 785 790 800
 Glu Met Ala Arg Glu Asn Gln Thr Thr Gln Lys Gly Gln Lys Asn Ser
 805 810 815
 Arg Glu Arg Met Lys Arg Ile Glu Glu Gly Ile Lys Glu Leu Gly Ser
 820 825 830
 Gln Ile Leu Lys Glu His Pro Val Glu Asn Thr Gln Leu Gln Asn Glu
 835 840 845
 Lys Leu Tyr Leu Tyr Tyr Leu Gln Asn Gly Arg Asp Met Tyr Val Asp
 850 855 860
 Gln Glu Leu Asp Ile Asn Arg Leu Ser Asp Tyr Asp Val Asp His Ile
 865 870 875 880
 Val Pro Gln Ser Phe Leu Lys Asp Asp Ser Ile Asp Asn Lys Val Leu
 885 890 895
 Thr Arg Ser Asp Lys Asn Arg Gly Lys Ser Asp Asn Val Pro Ser Glu
 900 905 910
 Glu Val Val Lys Lys Met Lys Asn Tyr Trp Arg Gln Leu Leu Asn Ala
 915 920 925
 Lys Leu Ile Thr Gln Arg Lys Phe Asp Asn Leu Thr Lys Ala Glu Arg
 930 935 940
 Gly Gly Leu Ser Glu Leu Asp Lys Ala Gly Phe Ile Lys Arg Gln Leu
 945 950 955 960
 Val Glu Thr Arg Gln Ile Thr Lys His Val Ala Gln Ile Leu Asp Ser
 965 970 975
 Arg Met Asn Thr Lys Tyr Asp Glu Asn Asp Lys Leu Ile Arg Glu Val
 980 985 990
 Lys Val Ile Thr Leu Lys Ser Lys Leu Val Ser Asp Phe Arg Lys Asp
 995 1000 1005
 Phe Gln Phe Tyr Lys Val Arg Glu Ile Asn Asn Tyr His His Ala
 1010 1015 1020
 His Asp Ala Tyr Leu Asn Ala Val Val Gly Thr Ala Leu Ile Lys
 1025 1030 1035
 Lys Tyr Pro Lys Leu Glu Ser Glu Phe Val Tyr Gly Asp Tyr Lys

-continued

1040	1045	1050
Val Tyr Asp Val Arg Lys Met	Ile Ala Lys Ser	Glu Gln Glu Ile
1055	1060	1065
Gly Lys Ala Thr Ala Lys Tyr	Phe Phe Tyr Ser	Asn Ile Met Asn
1070	1075	1080
Phe Phe Lys Thr Glu Ile Thr	Leu Ala Asn Gly	Glu Ile Arg Lys
1085	1090	1095
Arg Pro Leu Ile Glu Thr Asn	Gly Glu Thr Gly	Glu Ile Val Trp
1100	1105	1110
Asp Lys Gly Arg Asp Phe Ala	Thr Val Arg Lys	Val Leu Ser Met
1115	1120	1125
Pro Gln Val Asn Ile Val Lys	Lys Thr Glu Val	Gln Thr Gly Gly
1130	1135	1140
Phe Ser Lys Glu Ser Ile Leu	Pro Lys Arg Asn	Ser Asp Lys Leu
1145	1150	1155
Ile Ala Arg Lys Lys Asp Trp	Asp Pro Lys Lys	Tyr Gly Gly Phe
1160	1165	1170
Asp Ser Pro Thr Val Ala Tyr	Ser Val Leu Val	Val Ala Lys Val
1175	1180	1185
Glu Lys Gly Lys Ser Lys Lys	Leu Lys Ser Val	Lys Glu Leu Leu
1190	1195	1200
Gly Ile Thr Ile Met Glu Arg	Ser Ser Phe Glu	Lys Asn Pro Ile
1205	1210	1215
Asp Phe Leu Glu Ala Lys Gly	Tyr Lys Glu Val	Lys Lys Asp Leu
1220	1225	1230
Ile Ile Lys Leu Pro Lys Tyr	Ser Leu Phe Glu	Leu Glu Asn Gly
1235	1240	1245
Arg Lys Arg Met Leu Ala Ser	Ala Gly Glu Leu	Gln Lys Gly Asn
1250	1255	1260
Glu Leu Ala Leu Pro Ser Lys	Tyr Val Asn Phe	Leu Tyr Leu Ala
1265	1270	1275
Ser His Tyr Glu Lys Leu Lys	Gly Ser Pro Glu	Asp Asn Glu Gln
1280	1285	1290
Lys Gln Leu Phe Val Glu Gln	His Lys His Tyr	Leu Asp Glu Ile
1295	1300	1305
Ile Glu Gln Ile Ser Glu Phe	Ser Lys Arg Val	Ile Leu Ala Asp
1310	1315	1320
Ala Asn Leu Asp Lys Val Leu	Ser Ala Tyr Asn	Lys His Arg Asp
1325	1330	1335
Lys Pro Ile Arg Glu Gln Ala	Glu Asn Ile Ile	His Leu Phe Thr
1340	1345	1350
Leu Thr Asn Leu Gly Ala Pro	Ala Ala Phe Lys	Tyr Phe Asp Thr
1355	1360	1365
Thr Ile Asp Arg Lys Arg Tyr	Thr Ser Thr Lys	Glu Val Leu Asp
1370	1375	1380
Ala Thr Leu Ile His Gln Ser	Ile Thr Gly Leu	Tyr Glu Thr Arg
1385	1390	1395
Ile Asp Leu Ser Gln Leu Gly	Gly Asp Ala Ala	Ala Val Ser Lys
1400	1405	1410
Gly Glu Glu Leu Phe Thr Gly	Val Val Pro Ile	Leu Val Glu Leu
1415	1420	1425

-continued

Asp Gly Asp Val Asn Gly His Lys Phe Ser Val Ser Gly Glu Gly
 1430 1435 1440
 Glu Gly Asp Ala Thr Tyr Gly Lys Leu Thr Leu Lys Phe Ile Cys
 1445 1450 1455
 Thr Thr Gly Lys Leu Pro Val Pro Trp Pro Thr Leu Val Thr Thr
 1460 1465 1470
 Leu Thr Tyr Gly Val Gln Cys Phe Ser Arg Tyr Pro Asp His Met
 1475 1480 1485
 Lys Gln His Asp Phe Phe Lys Ser Ala Met Pro Glu Gly Tyr Val
 1490 1495 1500
 Gln Glu Arg Thr Ile Phe Phe Lys Asp Asp Gly Asn Tyr Lys Thr
 1505 1510 1515
 Arg Ala Glu Val Lys Phe Glu Gly Asp Thr Leu Val Asn Arg Ile
 1520 1525 1530
 Glu Leu Lys Gly Ile Asp Phe Lys Glu Asp Gly Asn Ile Leu Gly
 1535 1540 1545
 His Lys Leu Glu Tyr Asn Tyr Asn Ser His Asn Val Tyr Ile Met
 1550 1555 1560
 Ala Asp Lys Gln Lys Asn Gly Ile Lys Val Asn Phe Lys Ile Arg
 1565 1570 1575
 His Asn Ile Glu Asp Gly Ser Val Gln Leu Ala Asp His Tyr Gln
 1580 1585 1590
 Gln Asn Thr Pro Ile Gly Asp Gly Pro Val Leu Leu Pro Asp Asn
 1595 1600 1605
 His Tyr Leu Ser Thr Gln Ser Ala Leu Ser Lys Asp Pro Asn Glu
 1610 1615 1620
 Lys Arg Asp His Met Val Leu Leu Glu Phe Val Thr Ala Ala Gly
 1625 1630 1635
 Ile Thr Leu Gly Met Asp Glu Leu Tyr Lys
 1640 1645

<210> SEQ ID NO 45

<211> LENGTH: 1625

<212> TYPE: PRT

<213> ORGANISM: Artificial Sequence

<220> FEATURE:

<223> OTHER INFORMATION: Description of Artificial Sequence: Synthetic polypeptide

<400> SEQUENCE: 45

Met Asp Lys Lys Tyr Ser Ile Gly Leu Asp Ile Gly Thr Asn Ser Val
 1 5 10 15
 Gly Trp Ala Val Ile Thr Asp Glu Tyr Lys Val Pro Ser Lys Lys Phe
 20 25 30
 Lys Val Leu Gly Asn Thr Asp Arg His Ser Ile Lys Lys Asn Leu Ile
 35 40 45
 Gly Ala Leu Leu Phe Asp Ser Gly Glu Thr Ala Glu Ala Thr Arg Leu
 50 55 60
 Lys Arg Thr Ala Arg Arg Arg Tyr Thr Arg Arg Lys Asn Arg Ile Cys
 65 70 75 80
 Tyr Leu Gln Glu Ile Phe Ser Asn Glu Met Ala Lys Val Asp Asp Ser
 85 90 95
 Phe Phe His Arg Leu Glu Glu Ser Phe Leu Val Glu Glu Asp Lys Lys

-continued

100				105				110							
His	Glu	Arg	His	Pro	Ile	Phe	Gly	Asn	Ile	Val	Asp	Glu	Val	Ala	Tyr
	115						120					125			
His	Glu	Lys	Tyr	Pro	Thr	Ile	Tyr	His	Leu	Arg	Lys	Lys	Leu	Val	Asp
	130					135					140				
Ser	Thr	Asp	Lys	Ala	Asp	Leu	Arg	Leu	Ile	Tyr	Leu	Ala	Leu	Ala	His
	145				150					155					160
Met	Ile	Lys	Phe	Arg	Gly	His	Phe	Leu	Ile	Glu	Gly	Asp	Leu	Asn	Pro
			165						170					175	
Asp	Asn	Ser	Asp	Val	Asp	Lys	Leu	Phe	Ile	Gln	Leu	Val	Gln	Thr	Tyr
	180							185					190		
Asn	Gln	Leu	Phe	Glu	Glu	Asn	Pro	Ile	Asn	Ala	Ser	Gly	Val	Asp	Ala
	195						200					205			
Lys	Ala	Ile	Leu	Ser	Ala	Arg	Leu	Ser	Lys	Ser	Arg	Arg	Leu	Glu	Asn
	210					215					220				
Leu	Ile	Ala	Gln	Leu	Pro	Gly	Glu	Lys	Lys	Asn	Gly	Leu	Phe	Gly	Asn
	225				230					235					240
Leu	Ile	Ala	Leu	Ser	Leu	Gly	Leu	Thr	Pro	Asn	Phe	Lys	Ser	Asn	Phe
			245						250					255	
Asp	Leu	Ala	Glu	Asp	Ala	Lys	Leu	Gln	Leu	Ser	Lys	Asp	Thr	Tyr	Asp
	260							265					270		
Asp	Asp	Leu	Asp	Asn	Leu	Leu	Ala	Gln	Ile	Gly	Asp	Gln	Tyr	Ala	Asp
	275					280						285			
Leu	Phe	Leu	Ala	Ala	Lys	Asn	Leu	Ser	Asp	Ala	Ile	Leu	Leu	Ser	Asp
	290					295					300				
Ile	Leu	Arg	Val	Asn	Thr	Glu	Ile	Thr	Lys	Ala	Pro	Leu	Ser	Ala	Ser
	305				310						315				320
Met	Ile	Lys	Arg	Tyr	Asp	Glu	His	His	Gln	Asp	Leu	Thr	Leu	Leu	Lys
			325						330					335	
Ala	Leu	Val	Arg	Gln	Gln	Leu	Pro	Glu	Lys	Tyr	Lys	Glu	Ile	Phe	Phe
			340					345						350	
Asp	Gln	Ser	Lys	Asn	Gly	Tyr	Ala	Gly	Tyr	Ile	Asp	Gly	Gly	Ala	Ser
	355						360					365			
Gln	Glu	Glu	Phe	Tyr	Lys	Phe	Ile	Lys	Pro	Ile	Leu	Glu	Lys	Met	Asp
	370					375					380				
Gly	Thr	Glu	Glu	Leu	Leu	Val	Lys	Leu	Asn	Arg	Glu	Asp	Leu	Leu	Arg
	385				390					395					400
Lys	Gln	Arg	Thr	Phe	Asp	Asn	Gly	Ser	Ile	Pro	His	Gln	Ile	His	Leu
			405						410					415	
Gly	Glu	Leu	His	Ala	Ile	Leu	Arg	Arg	Gln	Glu	Asp	Phe	Tyr	Pro	Phe
			420					425						430	
Leu	Lys	Asp	Asn	Arg	Glu	Lys	Ile	Glu	Lys	Ile	Leu	Thr	Phe	Arg	Ile
	435						440					445			
Pro	Tyr	Tyr	Val	Gly	Pro	Leu	Ala	Arg	Gly	Asn	Ser	Arg	Phe	Ala	Trp
	450					455					460				
Met	Thr	Arg	Lys	Ser	Glu	Glu	Thr	Ile	Thr	Pro	Trp	Asn	Phe	Glu	Glu
	465				470					475				480	
Val	Val	Asp	Lys	Gly	Ala	Ser	Ala	Gln	Ser	Phe	Ile	Glu	Arg	Met	Thr
			485						490					495	
Asn	Phe	Asp	Lys	Asn	Leu	Pro	Asn	Glu	Lys	Val	Leu	Pro	Lys	His	Ser
			500					505						510	

-continued

Leu Leu Tyr Glu Tyr Phe Thr Val Tyr Asn Glu Leu Thr Lys Val Lys
 515 520 525
 Tyr Val Thr Glu Gly Met Arg Lys Pro Ala Phe Leu Ser Gly Glu Gln
 530 535 540
 Lys Lys Ala Ile Val Asp Leu Leu Phe Lys Thr Asn Arg Lys Val Thr
 545 550 555 560
 Val Lys Gln Leu Lys Glu Asp Tyr Phe Lys Lys Ile Glu Cys Phe Asp
 565 570 575
 Ser Val Glu Ile Ser Gly Val Glu Asp Arg Phe Asn Ala Ser Leu Gly
 580 585 590
 Thr Tyr His Asp Leu Leu Lys Ile Ile Lys Asp Lys Asp Phe Leu Asp
 595 600 605
 Asn Glu Glu Asn Glu Asp Ile Leu Glu Asp Ile Val Leu Thr Leu Thr
 610 615 620
 Leu Phe Glu Asp Arg Glu Met Ile Glu Glu Arg Leu Lys Thr Tyr Ala
 625 630 635 640
 His Leu Phe Asp Asp Lys Val Met Lys Gln Leu Lys Arg Arg Arg Tyr
 645 650 655
 Thr Gly Trp Gly Arg Leu Ser Arg Lys Leu Ile Asn Gly Ile Arg Asp
 660 665 670
 Lys Gln Ser Gly Lys Thr Ile Leu Asp Phe Leu Lys Ser Asp Gly Phe
 675 680 685
 Ala Asn Arg Asn Phe Met Gln Leu Ile His Asp Asp Ser Leu Thr Phe
 690 695 700
 Lys Glu Asp Ile Gln Lys Ala Gln Val Ser Gly Gln Gly Asp Ser Leu
 705 710 715 720
 His Glu His Ile Ala Asn Leu Ala Gly Ser Pro Ala Ile Lys Lys Gly
 725 730 735
 Ile Leu Gln Thr Val Lys Val Val Asp Glu Leu Val Lys Val Met Gly
 740 745 750
 Arg His Lys Pro Glu Asn Ile Val Ile Glu Met Ala Arg Glu Asn Gln
 755 760 765
 Thr Thr Gln Lys Gly Gln Lys Asn Ser Arg Glu Arg Met Lys Arg Ile
 770 775 780
 Glu Glu Gly Ile Lys Glu Leu Gly Ser Gln Ile Leu Lys Glu His Pro
 785 790 795 800
 Val Glu Asn Thr Gln Leu Gln Asn Glu Lys Leu Tyr Leu Tyr Tyr Leu
 805 810 815
 Gln Asn Gly Arg Asp Met Tyr Val Asp Gln Glu Leu Asp Ile Asn Arg
 820 825 830
 Leu Ser Asp Tyr Asp Val Asp His Ile Val Pro Gln Ser Phe Leu Lys
 835 840 845
 Asp Asp Ser Ile Asp Asn Lys Val Leu Thr Arg Ser Asp Lys Asn Arg
 850 855 860
 Gly Lys Ser Asp Asn Val Pro Ser Glu Glu Val Val Lys Lys Met Lys
 865 870 875 880
 Asn Tyr Trp Arg Gln Leu Leu Asn Ala Lys Leu Ile Thr Gln Arg Lys
 885 890 895
 Phe Asp Asn Leu Thr Lys Ala Glu Arg Gly Gly Leu Ser Glu Leu Asp
 900 905 910

-continued

Lys Ala Gly Phe Ile Lys Arg Gln Leu Val Glu Thr Arg Gln Ile Thr
 915 920 925
 Lys His Val Ala Gln Ile Leu Asp Ser Arg Met Asn Thr Lys Tyr Asp
 930 935 940
 Glu Asn Asp Lys Leu Ile Arg Glu Val Lys Val Ile Thr Leu Lys Ser
 945 950 955 960
 Lys Leu Val Ser Asp Phe Arg Lys Asp Phe Gln Phe Tyr Lys Val Arg
 965 970 975
 Glu Ile Asn Asn Tyr His His Ala His Asp Ala Tyr Leu Asn Ala Val
 980 985 990
 Val Gly Thr Ala Leu Ile Lys Lys Tyr Pro Lys Leu Glu Ser Glu Phe
 995 1000 1005
 Val Tyr Gly Asp Tyr Lys Val Tyr Asp Val Arg Lys Met Ile Ala
 1010 1015 1020
 Lys Ser Glu Gln Glu Ile Gly Lys Ala Thr Ala Lys Tyr Phe Phe
 1025 1030 1035
 Tyr Ser Asn Ile Met Asn Phe Phe Lys Thr Glu Ile Thr Leu Ala
 1040 1045 1050
 Asn Gly Glu Ile Arg Lys Arg Pro Leu Ile Glu Thr Asn Gly Glu
 1055 1060 1065
 Thr Gly Glu Ile Val Trp Asp Lys Gly Arg Asp Phe Ala Thr Val
 1070 1075 1080
 Arg Lys Val Leu Ser Met Pro Gln Val Asn Ile Val Lys Lys Thr
 1085 1090 1095
 Glu Val Gln Thr Gly Gly Phe Ser Lys Glu Ser Ile Leu Pro Lys
 1100 1105 1110
 Arg Asn Ser Asp Lys Leu Ile Ala Arg Lys Lys Asp Trp Asp Pro
 1115 1120 1125
 Lys Lys Tyr Gly Gly Phe Asp Ser Pro Thr Val Ala Tyr Ser Val
 1130 1135 1140
 Leu Val Val Ala Lys Val Glu Lys Gly Lys Ser Lys Lys Leu Lys
 1145 1150 1155
 Ser Val Lys Glu Leu Leu Gly Ile Thr Ile Met Glu Arg Ser Ser
 1160 1165 1170
 Phe Glu Lys Asn Pro Ile Asp Phe Leu Glu Ala Lys Gly Tyr Lys
 1175 1180 1185
 Glu Val Lys Lys Asp Leu Ile Ile Lys Leu Pro Lys Tyr Ser Leu
 1190 1195 1200
 Phe Glu Leu Glu Asn Gly Arg Lys Arg Met Leu Ala Ser Ala Gly
 1205 1210 1215
 Glu Leu Gln Lys Gly Asn Glu Leu Ala Leu Pro Ser Lys Tyr Val
 1220 1225 1230
 Asn Phe Leu Tyr Leu Ala Ser His Tyr Glu Lys Leu Lys Gly Ser
 1235 1240 1245
 Pro Glu Asp Asn Glu Gln Lys Gln Leu Phe Val Glu Gln His Lys
 1250 1255 1260
 His Tyr Leu Asp Glu Ile Ile Glu Gln Ile Ser Glu Phe Ser Lys
 1265 1270 1275
 Arg Val Ile Leu Ala Asp Ala Asn Leu Asp Lys Val Leu Ser Ala
 1280 1285 1290
 Tyr Asn Lys His Arg Asp Lys Pro Ile Arg Glu Gln Ala Glu Asn

-continued

1295	1300	1305
Ile Ile His Leu Phe Thr Leu Thr Asn Leu Gly Ala Pro Ala Ala 1310 1315 1320		
Phe Lys Tyr Phe Asp Thr Thr Ile Asp Arg Lys Arg Tyr Thr Ser 1325 1330 1335		
Thr Lys Glu Val Leu Asp Ala Thr Leu Ile His Gln Ser Ile Thr 1340 1345 1350		
Gly Leu Tyr Glu Thr Arg Ile Asp Leu Ser Gln Leu Gly Gly Asp 1355 1360 1365		
Ala Ala Ala Val Ser Lys Gly Glu Glu Leu Phe Thr Gly Val Val 1370 1375 1380		
Pro Ile Leu Val Glu Leu Asp Gly Asp Val Asn Gly His Lys Phe 1385 1390 1395		
Ser Val Ser Gly Glu Gly Glu Gly Asp Ala Thr Tyr Gly Lys Leu 1400 1405 1410		
Thr Leu Lys Phe Ile Cys Thr Thr Gly Lys Leu Pro Val Pro Trp 1415 1420 1425		
Pro Thr Leu Val Thr Thr Leu Thr Tyr Gly Val Gln Cys Phe Ser 1430 1435 1440		
Arg Tyr Pro Asp His Met Lys Gln His Asp Phe Phe Lys Ser Ala 1445 1450 1455		
Met Pro Glu Gly Tyr Val Gln Glu Arg Thr Ile Phe Phe Lys Asp 1460 1465 1470		
Asp Gly Asn Tyr Lys Thr Arg Ala Glu Val Lys Phe Glu Gly Asp 1475 1480 1485		
Thr Leu Val Asn Arg Ile Glu Leu Lys Gly Ile Asp Phe Lys Glu 1490 1495 1500		
Asp Gly Asn Ile Leu Gly His Lys Leu Glu Tyr Asn Tyr Asn Ser 1505 1510 1515		
His Asn Val Tyr Ile Met Ala Asp Lys Gln Lys Asn Gly Ile Lys 1520 1525 1530		
Val Asn Phe Lys Ile Arg His Asn Ile Glu Asp Gly Ser Val Gln 1535 1540 1545		
Leu Ala Asp His Tyr Gln Gln Asn Thr Pro Ile Gly Asp Gly Pro 1550 1555 1560		
Val Leu Leu Pro Asp Asn His Tyr Leu Ser Thr Gln Ser Ala Leu 1565 1570 1575		
Ser Lys Asp Pro Asn Glu Lys Arg Asp His Met Val Leu Leu Glu 1580 1585 1590		
Phe Val Thr Ala Ala Gly Ile Thr Leu Gly Met Asp Glu Leu Tyr 1595 1600 1605		
Lys Lys Arg Pro Ala Ala Thr Lys Lys Ala Gly Gln Ala Lys Lys 1610 1615 1620		
Lys Lys 1625		

<210> SEQ ID NO 46

<211> LENGTH: 1664

<212> TYPE: PRT

<213> ORGANISM: Artificial Sequence

<220> FEATURE:

<223> OTHER INFORMATION: Description of Artificial Sequence: Synthetic polypeptide

-continued

<400> SEQUENCE: 46

Met Asp Tyr Lys Asp His Asp Gly Asp Tyr Lys Asp His Asp Ile Asp
 1 5 10 15
 Tyr Lys Asp Asp Asp Asp Lys Met Ala Pro Lys Lys Lys Arg Lys Val
 20 25 30
 Gly Ile His Gly Val Pro Ala Ala Asp Lys Lys Tyr Ser Ile Gly Leu
 35 40 45
 Asp Ile Gly Thr Asn Ser Val Gly Trp Ala Val Ile Thr Asp Glu Tyr
 50 55 60
 Lys Val Pro Ser Lys Lys Phe Lys Val Leu Gly Asn Thr Asp Arg His
 65 70 75 80
 Ser Ile Lys Lys Asn Leu Ile Gly Ala Leu Leu Phe Asp Ser Gly Glu
 85 90 95
 Thr Ala Glu Ala Thr Arg Leu Lys Arg Thr Ala Arg Arg Arg Tyr Thr
 100 105 110
 Arg Arg Lys Asn Arg Ile Cys Tyr Leu Gln Glu Ile Phe Ser Asn Glu
 115 120 125
 Met Ala Lys Val Asp Asp Ser Phe Phe His Arg Leu Glu Glu Ser Phe
 130 135 140
 Leu Val Glu Glu Asp Lys Lys His Glu Arg His Pro Ile Phe Gly Asn
 145 150 155 160
 Ile Val Asp Glu Val Ala Tyr His Glu Lys Tyr Pro Thr Ile Tyr His
 165 170 175
 Leu Arg Lys Lys Leu Val Asp Ser Thr Asp Lys Ala Asp Leu Arg Leu
 180 185 190
 Ile Tyr Leu Ala Leu Ala His Met Ile Lys Phe Arg Gly His Phe Leu
 195 200 205
 Ile Glu Gly Asp Leu Asn Pro Asp Asn Ser Asp Val Asp Lys Leu Phe
 210 215 220
 Ile Gln Leu Val Gln Thr Tyr Asn Gln Leu Phe Glu Glu Asn Pro Ile
 225 230 235 240
 Asn Ala Ser Gly Val Asp Ala Lys Ala Ile Leu Ser Ala Arg Leu Ser
 245 250 255
 Lys Ser Arg Arg Leu Glu Asn Leu Ile Ala Gln Leu Pro Gly Glu Lys
 260 265 270
 Lys Asn Gly Leu Phe Gly Asn Leu Ile Ala Leu Ser Leu Gly Leu Thr
 275 280 285
 Pro Asn Phe Lys Ser Asn Phe Asp Leu Ala Glu Asp Ala Lys Leu Gln
 290 295 300
 Leu Ser Lys Asp Thr Tyr Asp Asp Asp Leu Asp Asn Leu Leu Ala Gln
 305 310 315 320
 Ile Gly Asp Gln Tyr Ala Asp Leu Phe Leu Ala Ala Lys Asn Leu Ser
 325 330 335
 Asp Ala Ile Leu Leu Ser Asp Ile Leu Arg Val Asn Thr Glu Ile Thr
 340 345 350
 Lys Ala Pro Leu Ser Ala Ser Met Ile Lys Arg Tyr Asp Glu His His
 355 360 365
 Gln Asp Leu Thr Leu Leu Lys Ala Leu Val Arg Gln Gln Leu Pro Glu
 370 375 380
 Lys Tyr Lys Glu Ile Phe Phe Asp Gln Ser Lys Asn Gly Tyr Ala Gly

-continued

385		390		395		400									
Tyr	Ile	Asp	Gly	Gly	Ala	Ser	Gln	Glu	Glu	Phe	Tyr	Lys	Phe	Ile	Lys
			405					410						415	
Pro	Ile	Leu	Glu	Lys	Met	Asp	Gly	Thr	Glu	Glu	Leu	Leu	Val	Lys	Leu
			420					425					430		
Asn	Arg	Glu	Asp	Leu	Leu	Arg	Lys	Gln	Arg	Thr	Phe	Asp	Asn	Gly	Ser
		435					440					445			
Ile	Pro	His	Gln	Ile	His	Leu	Gly	Glu	Leu	His	Ala	Ile	Leu	Arg	Arg
	450				455						460				
Gln	Glu	Asp	Phe	Tyr	Pro	Phe	Leu	Lys	Asp	Asn	Arg	Glu	Lys	Ile	Glu
465					470						475				480
Lys	Ile	Leu	Thr	Phe	Arg	Ile	Pro	Tyr	Tyr	Val	Gly	Pro	Leu	Ala	Arg
				485					490						495
Gly	Asn	Ser	Arg	Phe	Ala	Trp	Met	Thr	Arg	Lys	Ser	Glu	Glu	Thr	Ile
			500						505					510	
Thr	Pro	Trp	Asn	Phe	Glu	Glu	Val	Val	Asp	Lys	Gly	Ala	Ser	Ala	Gln
		515						520				525			
Ser	Phe	Ile	Glu	Arg	Met	Thr	Asn	Phe	Asp	Lys	Asn	Leu	Pro	Asn	Glu
	530					535					540				
Lys	Val	Leu	Pro	Lys	His	Ser	Leu	Leu	Tyr	Glu	Tyr	Phe	Thr	Val	Tyr
545					550					555					560
Asn	Glu	Leu	Thr	Lys	Val	Lys	Tyr	Val	Thr	Glu	Gly	Met	Arg	Lys	Pro
				565					570					575	
Ala	Phe	Leu	Ser	Gly	Glu	Gln	Lys	Lys	Ala	Ile	Val	Asp	Leu	Leu	Phe
			580					585					590		
Lys	Thr	Asn	Arg	Lys	Val	Thr	Val	Lys	Gln	Leu	Lys	Glu	Asp	Tyr	Phe
		595					600					605			
Lys	Lys	Ile	Glu	Cys	Phe	Asp	Ser	Val	Glu	Ile	Ser	Gly	Val	Glu	Asp
610						615						620			
Arg	Phe	Asn	Ala	Ser	Leu	Gly	Thr	Tyr	His	Asp	Leu	Leu	Lys	Ile	Ile
625					630					635					640
Lys	Asp	Lys	Asp	Phe	Leu	Asp	Asn	Glu	Glu	Asn	Glu	Asp	Ile	Leu	Glu
				645					650					655	
Asp	Ile	Val	Leu	Thr	Leu	Thr	Leu	Phe	Glu	Asp	Arg	Glu	Met	Ile	Glu
			660					665						670	
Glu	Arg	Leu	Lys	Thr	Tyr	Ala	His	Leu	Phe	Asp	Asp	Lys	Val	Met	Lys
		675					680					685			
Gln	Leu	Lys	Arg	Arg	Arg	Tyr	Thr	Gly	Trp	Gly	Arg	Leu	Ser	Arg	Lys
690						695						700			
Leu	Ile	Asn	Gly	Ile	Arg	Asp	Lys	Gln	Ser	Gly	Lys	Thr	Ile	Leu	Asp
705					710					715					720
Phe	Leu	Lys	Ser	Asp	Gly	Phe	Ala	Asn	Arg	Asn	Phe	Met	Gln	Leu	Ile
				725					730					735	
His	Asp	Asp	Ser	Leu	Thr	Phe	Lys	Glu	Asp	Ile	Gln	Lys	Ala	Gln	Val
			740					745					750		
Ser	Gly	Gln	Gly	Asp	Ser	Leu	His	Glu	His	Ile	Ala	Asn	Leu	Ala	Gly
		755					760					765			
Ser	Pro	Ala	Ile	Lys	Lys	Gly	Ile	Leu	Gln	Thr	Val	Lys	Val	Val	Asp
	770					775						780			
Glu	Leu	Val	Lys	Val	Met	Gly	Arg	His	Lys	Pro	Glu	Asn	Ile	Val	Ile
785					790					795					800

-continued

Glu Met Ala Arg Glu Asn Gln Thr Thr Gln Lys Gly Gln Lys Asn Ser
805 810 815

Arg Glu Arg Met Lys Arg Ile Glu Glu Gly Ile Lys Glu Leu Gly Ser
820 825 830

Gln Ile Leu Lys Glu His Pro Val Glu Asn Thr Gln Leu Gln Asn Glu
835 840 845

Lys Leu Tyr Leu Tyr Tyr Leu Gln Asn Gly Arg Asp Met Tyr Val Asp
850 855 860

Gln Glu Leu Asp Ile Asn Arg Leu Ser Asp Tyr Asp Val Asp His Ile
865 870 875 880

Val Pro Gln Ser Phe Leu Lys Asp Asp Ser Ile Asp Asn Lys Val Leu
885 890 895

Thr Arg Ser Asp Lys Asn Arg Gly Lys Ser Asp Asn Val Pro Ser Glu
900 905 910

Glu Val Val Lys Lys Met Lys Asn Tyr Trp Arg Gln Leu Leu Asn Ala
915 920 925

Lys Leu Ile Thr Gln Arg Lys Phe Asp Asn Leu Thr Lys Ala Glu Arg
930 935 940

Gly Gly Leu Ser Glu Leu Asp Lys Ala Gly Phe Ile Lys Arg Gln Leu
945 950 955 960

Val Glu Thr Arg Gln Ile Thr Lys His Val Ala Gln Ile Leu Asp Ser
965 970 975

Arg Met Asn Thr Lys Tyr Asp Glu Asn Asp Lys Leu Ile Arg Glu Val
980 985 990

Lys Val Ile Thr Leu Lys Ser Lys Leu Val Ser Asp Phe Arg Lys Asp
995 1000 1005

Phe Gln Phe Tyr Lys Val Arg Glu Ile Asn Asn Tyr His His Ala
1010 1015 1020

His Asp Ala Tyr Leu Asn Ala Val Val Gly Thr Ala Leu Ile Lys
1025 1030 1035

Lys Tyr Pro Lys Leu Glu Ser Glu Phe Val Tyr Gly Asp Tyr Lys
1040 1045 1050

Val Tyr Asp Val Arg Lys Met Ile Ala Lys Ser Glu Gln Glu Ile
1055 1060 1065

Gly Lys Ala Thr Ala Lys Tyr Phe Phe Tyr Ser Asn Ile Met Asn
1070 1075 1080

Phe Phe Lys Thr Glu Ile Thr Leu Ala Asn Gly Glu Ile Arg Lys
1085 1090 1095

Arg Pro Leu Ile Glu Thr Asn Gly Glu Thr Gly Glu Ile Val Trp
1100 1105 1110

Asp Lys Gly Arg Asp Phe Ala Thr Val Arg Lys Val Leu Ser Met
1115 1120 1125

Pro Gln Val Asn Ile Val Lys Lys Thr Glu Val Gln Thr Gly Gly
1130 1135 1140

Phe Ser Lys Glu Ser Ile Leu Pro Lys Arg Asn Ser Asp Lys Leu
1145 1150 1155

Ile Ala Arg Lys Lys Asp Trp Asp Pro Lys Lys Tyr Gly Gly Phe
1160 1165 1170

Asp Ser Pro Thr Val Ala Tyr Ser Val Leu Val Val Ala Lys Val
1175 1180 1185

-continued

Glu	Lys	Gly	Lys	Ser	Lys	Lys	Leu	Lys	Ser	Val	Lys	Glu	Leu	Leu
1190						1195					1200			
Gly	Ile	Thr	Ile	Met	Glu	Arg	Ser	Ser	Phe	Glu	Lys	Asn	Pro	Ile
1205						1210					1215			
Asp	Phe	Leu	Glu	Ala	Lys	Gly	Tyr	Lys	Glu	Val	Lys	Lys	Asp	Leu
1220						1225					1230			
Ile	Ile	Lys	Leu	Pro	Lys	Tyr	Ser	Leu	Phe	Glu	Leu	Glu	Asn	Gly
1235						1240					1245			
Arg	Lys	Arg	Met	Leu	Ala	Ser	Ala	Gly	Glu	Leu	Gln	Lys	Gly	Asn
1250						1255					1260			
Glu	Leu	Ala	Leu	Pro	Ser	Lys	Tyr	Val	Asn	Phe	Leu	Tyr	Leu	Ala
1265						1270					1275			
Ser	His	Tyr	Glu	Lys	Leu	Lys	Gly	Ser	Pro	Glu	Asp	Asn	Glu	Gln
1280						1285					1290			
Lys	Gln	Leu	Phe	Val	Glu	Gln	His	Lys	His	Tyr	Leu	Asp	Glu	Ile
1295						1300					1305			
Ile	Glu	Gln	Ile	Ser	Glu	Phe	Ser	Lys	Arg	Val	Ile	Leu	Ala	Asp
1310						1315					1320			
Ala	Asn	Leu	Asp	Lys	Val	Leu	Ser	Ala	Tyr	Asn	Lys	His	Arg	Asp
1325						1330					1335			
Lys	Pro	Ile	Arg	Glu	Gln	Ala	Glu	Asn	Ile	Ile	His	Leu	Phe	Thr
1340						1345					1350			
Leu	Thr	Asn	Leu	Gly	Ala	Pro	Ala	Ala	Phe	Lys	Tyr	Phe	Asp	Thr
1355						1360					1365			
Thr	Ile	Asp	Arg	Lys	Arg	Tyr	Thr	Ser	Thr	Lys	Glu	Val	Leu	Asp
1370						1375					1380			
Ala	Thr	Leu	Ile	His	Gln	Ser	Ile	Thr	Gly	Leu	Tyr	Glu	Thr	Arg
1385						1390					1395			
Ile	Asp	Leu	Ser	Gln	Leu	Gly	Gly	Asp	Ala	Ala	Ala	Val	Ser	Lys
1400						1405					1410			
Gly	Glu	Glu	Leu	Phe	Thr	Gly	Val	Val	Pro	Ile	Leu	Val	Glu	Leu
1415						1420					1425			
Asp	Gly	Asp	Val	Asn	Gly	His	Lys	Phe	Ser	Val	Ser	Gly	Glu	Gly
1430						1435					1440			
Glu	Gly	Asp	Ala	Thr	Tyr	Gly	Lys	Leu	Thr	Leu	Lys	Phe	Ile	Cys
1445						1450					1455			
Thr	Thr	Gly	Lys	Leu	Pro	Val	Pro	Trp	Pro	Thr	Leu	Val	Thr	Thr
1460						1465					1470			
Leu	Thr	Tyr	Gly	Val	Gln	Cys	Phe	Ser	Arg	Tyr	Pro	Asp	His	Met
1475						1480					1485			
Lys	Gln	His	Asp	Phe	Phe	Lys	Ser	Ala	Met	Pro	Glu	Gly	Tyr	Val
1490						1495					1500			
Gln	Glu	Arg	Thr	Ile	Phe	Phe	Lys	Asp	Asp	Gly	Asn	Tyr	Lys	Thr
1505						1510					1515			
Arg	Ala	Glu	Val	Lys	Phe	Glu	Gly	Asp	Thr	Leu	Val	Asn	Arg	Ile
1520						1525					1530			
Glu	Leu	Lys	Gly	Ile	Asp	Phe	Lys	Glu	Asp	Gly	Asn	Ile	Leu	Gly
1535						1540					1545			
His	Lys	Leu	Glu	Tyr	Asn	Tyr	Asn	Ser	His	Asn	Val	Tyr	Ile	Met
1550						1555					1560			
Ala	Asp	Lys	Gln	Lys	Asn	Gly	Ile	Lys	Val	Asn	Phe	Lys	Ile	Arg

-continued

1565	1570	1575
His Asn Ile Glu Asp Gly Ser Val Gln Leu Ala Asp His Tyr Gln		
1580	1585	1590
Gln Asn Thr Pro Ile Gly Asp Gly Pro Val Leu Leu Pro Asp Asn		
1595	1600	1605
His Tyr Leu Ser Thr Gln Ser Ala Leu Ser Lys Asp Pro Asn Glu		
1610	1615	1620
Lys Arg Asp His Met Val Leu Leu Glu Phe Val Thr Ala Ala Gly		
1625	1630	1635
Ile Thr Leu Gly Met Asp Glu Leu Tyr Lys Lys Arg Pro Ala Ala		
1640	1645	1650
Thr Lys Lys Ala Gly Gln Ala Lys Lys Lys Lys		
1655	1660	

<210> SEQ ID NO 47

<211> LENGTH: 1423

<212> TYPE: PRT

<213> ORGANISM: Artificial Sequence

<220> FEATURE:

<223> OTHER INFORMATION: Description of Artificial Sequence: Synthetic polypeptide

<400> SEQUENCE: 47

Met Asp Tyr Lys Asp His Asp Gly Asp Tyr Lys Asp His Asp Ile Asp			
1	5	10	15
Tyr Lys Asp Asp Asp Asp Lys Met Ala Pro Lys Lys Lys Arg Lys Val			
	20	25	30
Gly Ile His Gly Val Pro Ala Ala Asp Lys Lys Tyr Ser Ile Gly Leu			
	35	40	45
Asp Ile Gly Thr Asn Ser Val Gly Trp Ala Val Ile Thr Asp Glu Tyr			
	50	55	60
Lys Val Pro Ser Lys Lys Phe Lys Val Leu Gly Asn Thr Asp Arg His			
	65	70	75
Ser Ile Lys Lys Asn Leu Ile Gly Ala Leu Leu Phe Asp Ser Gly Glu			
	85	90	95
Thr Ala Glu Ala Thr Arg Leu Lys Arg Thr Ala Arg Arg Arg Tyr Thr			
	100	105	110
Arg Arg Lys Asn Arg Ile Cys Tyr Leu Gln Glu Ile Phe Ser Asn Glu			
	115	120	125
Met Ala Lys Val Asp Asp Ser Phe Phe His Arg Leu Glu Glu Ser Phe			
	130	135	140
Leu Val Glu Glu Asp Lys Lys His Glu Arg His Pro Ile Phe Gly Asn			
	145	150	155
Ile Val Asp Glu Val Ala Tyr His Glu Lys Tyr Pro Thr Ile Tyr His			
	165	170	175
Leu Arg Lys Lys Leu Val Asp Ser Thr Asp Lys Ala Asp Leu Arg Leu			
	180	185	190
Ile Tyr Leu Ala Leu Ala His Met Ile Lys Phe Arg Gly His Phe Leu			
	195	200	205
Ile Glu Gly Asp Leu Asn Pro Asp Asn Ser Asp Val Asp Lys Leu Phe			
	210	215	220
Ile Gln Leu Val Gln Thr Tyr Asn Gln Leu Phe Glu Glu Asn Pro Ile			
	225	230	235
			240

-continued

Asn	Ala	Ser	Gly	Val	Asp	Ala	Lys	Ala	Ile	Leu	Ser	Ala	Arg	Leu	Ser	245	250	255
Lys	Ser	Arg	Arg	Leu	Glu	Asn	Leu	Ile	Ala	Gln	Leu	Pro	Gly	Glu	Lys	260	265	270
Lys	Asn	Gly	Leu	Phe	Gly	Asn	Leu	Ile	Ala	Leu	Ser	Leu	Gly	Leu	Thr	275	280	285
Pro	Asn	Phe	Lys	Ser	Asn	Phe	Asp	Leu	Ala	Glu	Asp	Ala	Lys	Leu	Gln	290	295	300
Leu	Ser	Lys	Asp	Thr	Tyr	Asp	Asp	Asp	Leu	Asp	Asn	Leu	Leu	Ala	Gln	305	310	315
Ile	Gly	Asp	Gln	Tyr	Ala	Asp	Leu	Phe	Leu	Ala	Ala	Lys	Asn	Leu	Ser	325	330	335
Asp	Ala	Ile	Leu	Leu	Ser	Asp	Ile	Leu	Arg	Val	Asn	Thr	Glu	Ile	Thr	340	345	350
Lys	Ala	Pro	Leu	Ser	Ala	Ser	Met	Ile	Lys	Arg	Tyr	Asp	Glu	His	His	355	360	365
Gln	Asp	Leu	Thr	Leu	Leu	Lys	Ala	Leu	Val	Arg	Gln	Gln	Leu	Pro	Glu	370	375	380
Lys	Tyr	Lys	Glu	Ile	Phe	Phe	Asp	Gln	Ser	Lys	Asn	Gly	Tyr	Ala	Gly	385	390	395
Tyr	Ile	Asp	Gly	Gly	Ala	Ser	Gln	Glu	Glu	Phe	Tyr	Lys	Phe	Ile	Lys	405	410	415
Pro	Ile	Leu	Glu	Lys	Met	Asp	Gly	Thr	Glu	Glu	Leu	Leu	Val	Lys	Leu	420	425	430
Asn	Arg	Glu	Asp	Leu	Leu	Arg	Lys	Gln	Arg	Thr	Phe	Asp	Asn	Gly	Ser	435	440	445
Ile	Pro	His	Gln	Ile	His	Leu	Gly	Glu	Leu	His	Ala	Ile	Leu	Arg	Arg	450	455	460
Gln	Glu	Asp	Phe	Tyr	Pro	Phe	Leu	Lys	Asp	Asn	Arg	Glu	Lys	Ile	Glu	465	470	475
Lys	Ile	Leu	Thr	Phe	Arg	Ile	Pro	Tyr	Tyr	Val	Gly	Pro	Leu	Ala	Arg	485	490	495
Gly	Asn	Ser	Arg	Phe	Ala	Trp	Met	Thr	Arg	Lys	Ser	Glu	Glu	Thr	Ile	500	505	510
Thr	Pro	Trp	Asn	Phe	Glu	Glu	Val	Val	Asp	Lys	Gly	Ala	Ser	Ala	Gln	515	520	525
Ser	Phe	Ile	Glu	Arg	Met	Thr	Asn	Phe	Asp	Lys	Asn	Leu	Pro	Asn	Glu	530	535	540
Lys	Val	Leu	Pro	Lys	His	Ser	Leu	Leu	Tyr	Glu	Tyr	Phe	Thr	Val	Tyr	545	550	555
Asn	Glu	Leu	Thr	Lys	Val	Lys	Tyr	Val	Thr	Glu	Gly	Met	Arg	Lys	Pro	565	570	575
Ala	Phe	Leu	Ser	Gly	Glu	Gln	Lys	Lys	Ala	Ile	Val	Asp	Leu	Leu	Phe	580	585	590
Lys	Thr	Asn	Arg	Lys	Val	Thr	Val	Lys	Gln	Leu	Lys	Glu	Asp	Tyr	Phe	595	600	605
Lys	Lys	Ile	Glu	Cys	Phe	Asp	Ser	Val	Glu	Ile	Ser	Gly	Val	Glu	Asp	610	615	620
Arg	Phe	Asn	Ala	Ser	Leu	Gly	Thr	Tyr	His	Asp	Leu	Leu	Lys	Ile	Ile	625	630	635
Lys	Asp	Lys	Asp	Phe	Leu	Asp	Asn	Glu	Glu	Asn	Glu	Asp	Ile	Leu	Glu			

-continued

645				650				655							
Asp	Ile	Val	Leu	Thr	Leu	Thr	Leu	Phe	Glu	Asp	Arg	Glu	Met	Ile	Glu
			660								665				670
Glu	Arg	Leu	Lys	Thr	Tyr	Ala	His	Leu	Phe	Asp	Asp	Lys	Val	Met	Lys
			675												685
Gln	Leu	Lys	Arg	Arg	Arg	Tyr	Thr	Gly	Trp	Gly	Arg	Leu	Ser	Arg	Lys
			690												700
Leu	Ile	Asn	Gly	Ile	Arg	Asp	Lys	Gln	Ser	Gly	Lys	Thr	Ile	Leu	Asp
															720
Phe	Leu	Lys	Ser	Asp	Gly	Phe	Ala	Asn	Arg	Asn	Phe	Met	Gln	Leu	Ile
															735
His	Asp	Asp	Ser	Leu	Thr	Phe	Lys	Glu	Asp	Ile	Gln	Lys	Ala	Gln	Val
															750
Ser	Gly	Gln	Gly	Asp	Ser	Leu	His	Glu	His	Ile	Ala	Asn	Leu	Ala	Gly
															765
Ser	Pro	Ala	Ile	Lys	Lys	Gly	Ile	Leu	Gln	Thr	Val	Lys	Val	Val	Asp
															780
Glu	Leu	Val	Lys	Val	Met	Gly	Arg	His	Lys	Pro	Glu	Asn	Ile	Val	Ile
															800
Glu	Met	Ala	Arg	Glu	Asn	Gln	Thr	Thr	Gln	Lys	Gly	Gln	Lys	Asn	Ser
															815
Arg	Glu	Arg	Met	Lys	Arg	Ile	Glu	Glu	Gly	Ile	Lys	Glu	Leu	Gly	Ser
															830
Gln	Ile	Leu	Lys	Glu	His	Pro	Val	Glu	Asn	Thr	Gln	Leu	Gln	Asn	Glu
															845
Lys	Leu	Tyr	Leu	Tyr	Tyr	Leu	Gln	Asn	Gly	Arg	Asp	Met	Tyr	Val	Asp
															860
Gln	Glu	Leu	Asp	Ile	Asn	Arg	Leu	Ser	Asp	Tyr	Asp	Val	Asp	His	Ile
															880
Val	Pro	Gln	Ser	Phe	Leu	Lys	Asp	Asp	Ser	Ile	Asp	Asn	Lys	Val	Leu
															895
Thr	Arg	Ser	Asp	Lys	Asn	Arg	Gly	Lys	Ser	Asp	Asn	Val	Pro	Ser	Glu
															910
Glu	Val	Val	Lys	Lys	Met	Lys	Asn	Tyr	Trp	Arg	Gln	Leu	Leu	Asn	Ala
															925
Lys	Leu	Ile	Thr	Gln	Arg	Lys	Phe	Asp	Asn	Leu	Thr	Lys	Ala	Glu	Arg
															940
Gly	Gly	Leu	Ser	Glu	Leu	Asp	Lys	Ala	Gly	Phe	Ile	Lys	Arg	Gln	Leu
															960
Val	Glu	Thr	Arg	Gln	Ile	Thr	Lys	His	Val	Ala	Gln	Ile	Leu	Asp	Ser
															975
Arg	Met	Asn	Thr	Lys	Tyr	Asp	Glu	Asn	Asp	Lys	Leu	Ile	Arg	Glu	Val
															990
Lys	Val	Ile	Thr	Leu	Lys	Ser	Lys	Leu	Val	Ser	Asp	Phe	Arg	Lys	Asp
															1005
Phe	Gln	Phe	Tyr	Lys	Val	Arg	Glu	Ile	Asn	Asn	Tyr	His	His	Ala	
															1020
His	Asp	Ala	Tyr	Leu	Asn	Ala	Val	Val	Gly	Thr	Ala	Leu	Ile	Lys	
															1035
Lys	Tyr	Pro	Lys	Leu	Glu	Ser	Glu	Phe	Val	Tyr	Gly	Asp	Tyr	Lys	
															1050

-continued

<210> SEQ ID NO 48
 <211> LENGTH: 483
 <212> TYPE: PRT
 <213> ORGANISM: Artificial Sequence
 <220> FEATURE:
 <223> OTHER INFORMATION: Description of Artificial Sequence: Synthetic polypeptide

<400> SEQUENCE: 48

Met Phe Leu Phe Leu Ser Leu Thr Ser Phe Leu Ser Ser Ser Arg Thr
 1 5 10 15
 Leu Val Ser Lys Gly Glu Glu Asp Asn Met Ala Ile Ile Lys Glu Phe
 20 25 30
 Met Arg Phe Lys Val His Met Glu Gly Ser Val Asn Gly His Glu Phe
 35 40 45
 Glu Ile Glu Gly Glu Gly Glu Gly Arg Pro Tyr Glu Gly Thr Gln Thr
 50 55 60
 Ala Lys Leu Lys Val Thr Lys Gly Gly Pro Leu Pro Phe Ala Trp Asp
 65 70 75 80
 Ile Leu Ser Pro Gln Phe Met Tyr Gly Ser Lys Ala Tyr Val Lys His
 85 90 95
 Pro Ala Asp Ile Pro Asp Tyr Leu Lys Leu Ser Phe Pro Glu Gly Phe
 100 105 110
 Lys Trp Glu Arg Val Met Asn Phe Glu Asp Gly Gly Val Val Thr Val
 115 120 125
 Thr Gln Asp Ser Ser Leu Gln Asp Gly Glu Phe Ile Tyr Lys Val Lys
 130 135 140
 Leu Arg Gly Thr Asn Phe Pro Ser Asp Gly Pro Val Met Gln Lys Lys
 145 150 155 160
 Thr Met Gly Trp Glu Ala Ser Ser Glu Arg Met Tyr Pro Glu Asp Gly
 165 170 175
 Ala Leu Lys Gly Glu Ile Lys Gln Arg Leu Lys Leu Lys Asp Gly Gly
 180 185 190
 His Tyr Asp Ala Glu Val Lys Thr Thr Tyr Lys Ala Lys Lys Pro Val
 195 200 205
 Gln Leu Pro Gly Ala Tyr Asn Val Asn Ile Lys Leu Asp Ile Thr Ser
 210 215 220
 His Asn Glu Asp Tyr Thr Ile Val Glu Gln Tyr Glu Arg Ala Glu Gly
 225 230 235 240
 Arg His Ser Thr Gly Gly Met Asp Glu Leu Tyr Lys Gly Ser Lys Gln
 245 250 255
 Leu Glu Glu Leu Leu Ser Thr Ser Phe Asp Ile Gln Phe Asn Asp Leu
 260 265 270
 Thr Leu Leu Glu Thr Ala Phe Thr His Thr Ser Tyr Ala Asn Glu His
 275 280 285
 Arg Leu Leu Asn Val Ser His Asn Glu Arg Leu Glu Phe Leu Gly Asp
 290 295 300
 Ala Val Leu Gln Leu Ile Ile Ser Glu Tyr Leu Phe Ala Lys Tyr Pro
 305 310 315 320
 Lys Lys Thr Glu Gly Asp Met Ser Lys Leu Arg Ser Met Ile Val Arg
 325 330 335
 Glu Glu Ser Leu Ala Gly Phe Ser Arg Phe Cys Ser Phe Asp Ala Tyr
 340 345 350

-continued

```

Ile Lys Leu Gly Lys Gly Glu Glu Lys Ser Gly Gly Arg Arg Arg Asp
   355                               360                               365
Thr Ile Leu Gly Asp Leu Phe Glu Ala Phe Leu Gly Ala Leu Leu Leu
   370                               375                               380
Asp Lys Gly Ile Asp Ala Val Arg Arg Phe Leu Lys Gln Val Met Ile
   385                               390                               395                               400
Pro Gln Val Glu Lys Gly Asn Phe Glu Arg Val Lys Asp Tyr Lys Thr
                               405                               410                               415
Cys Leu Gln Glu Phe Leu Gln Thr Lys Gly Asp Val Ala Ile Asp Tyr
                               420                               425                               430
Gln Val Ile Ser Glu Lys Gly Pro Ala His Ala Lys Gln Phe Glu Val
   435                               440                               445
Ser Ile Val Val Asn Gly Ala Val Leu Ser Lys Gly Leu Gly Lys Ser
   450                               455                               460
Lys Lys Leu Ala Glu Gln Asp Ala Ala Lys Asn Ala Leu Ala Gln Leu
   465                               470                               475                               480
Ser Glu Val

```

<210> SEQ ID NO 49

<211> LENGTH: 483

<212> TYPE: PRT

<213> ORGANISM: Artificial Sequence

<220> FEATURE:

<223> OTHER INFORMATION: Description of Artificial Sequence: Synthetic polypeptide

<400> SEQUENCE: 49

```

Met Lys Gln Leu Glu Glu Leu Leu Ser Thr Ser Phe Asp Ile Gln Phe
 1           5           10           15
Asn Asp Leu Thr Leu Leu Glu Thr Ala Phe Thr His Thr Ser Tyr Ala
 20           25           30
Asn Glu His Arg Leu Leu Asn Val Ser His Asn Glu Arg Leu Glu Phe
 35           40           45
Leu Gly Asp Ala Val Leu Gln Leu Ile Ile Ser Glu Tyr Leu Phe Ala
 50           55           60
Lys Tyr Pro Lys Lys Thr Glu Gly Asp Met Ser Lys Leu Arg Ser Met
 65           70           75           80
Ile Val Arg Glu Glu Ser Leu Ala Gly Phe Ser Arg Phe Cys Ser Phe
 85           90           95
Asp Ala Tyr Ile Lys Leu Gly Lys Gly Glu Glu Lys Ser Gly Gly Arg
100           105           110
Arg Arg Asp Thr Ile Leu Gly Asp Leu Phe Glu Ala Phe Leu Gly Ala
115           120           125
Leu Leu Leu Asp Lys Gly Ile Asp Ala Val Arg Arg Phe Leu Lys Gln
130           135           140
Val Met Ile Pro Gln Val Glu Lys Gly Asn Phe Glu Arg Val Lys Asp
145           150           155           160
Tyr Lys Thr Cys Leu Gln Glu Phe Leu Gln Thr Lys Gly Asp Val Ala
165           170           175
Ile Asp Tyr Gln Val Ile Ser Glu Lys Gly Pro Ala His Ala Lys Gln
180           185           190
Phe Glu Val Ser Ile Val Val Asn Gly Ala Val Leu Ser Lys Gly Leu
195           200           205

```

-continued

Gly Lys Ser Lys Lys Leu Ala Glu Gln Asp Ala Ala Lys Asn Ala Leu
 210 215 220

Ala Gln Leu Ser Glu Val Gly Ser Val Ser Lys Gly Glu Glu Asp Asn
 225 230 235 240

Met Ala Ile Ile Lys Glu Phe Met Arg Phe Lys Val His Met Glu Gly
 245 250 255

Ser Val Asn Gly His Glu Phe Glu Ile Glu Gly Glu Gly Glu Gly Arg
 260 265 270

Pro Tyr Glu Gly Thr Gln Thr Ala Lys Leu Lys Val Thr Lys Gly Gly
 275 280 285

Pro Leu Pro Phe Ala Trp Asp Ile Leu Ser Pro Gln Phe Met Tyr Gly
 290 295 300

Ser Lys Ala Tyr Val Lys His Pro Ala Asp Ile Pro Asp Tyr Leu Lys
 305 310 315 320

Leu Ser Phe Pro Glu Gly Phe Lys Trp Glu Arg Val Met Asn Phe Glu
 325 330 335

Asp Gly Gly Val Val Thr Val Thr Gln Asp Ser Ser Leu Gln Asp Gly
 340 345 350

Glu Phe Ile Tyr Lys Val Lys Leu Arg Gly Thr Asn Phe Pro Ser Asp
 355 360 365

Gly Pro Val Met Gln Lys Lys Thr Met Gly Trp Glu Ala Ser Ser Glu
 370 375 380

Arg Met Tyr Pro Glu Asp Gly Ala Leu Lys Gly Glu Ile Lys Gln Arg
 385 390 395 400

Leu Lys Leu Lys Asp Gly Gly His Tyr Asp Ala Glu Val Lys Thr Thr
 405 410 415

Tyr Lys Ala Lys Lys Pro Val Gln Leu Pro Gly Ala Tyr Asn Val Asn
 420 425 430

Ile Lys Leu Asp Ile Thr Ser His Asn Glu Asp Tyr Thr Ile Val Glu
 435 440 445

Gln Tyr Glu Arg Ala Glu Gly Arg His Ser Thr Gly Gly Met Asp Glu
 450 455 460

Leu Tyr Lys Lys Arg Pro Ala Ala Thr Lys Lys Ala Gly Gln Ala Lys
 465 470 475 480

Lys Lys Lys

<210> SEQ ID NO 50
 <211> LENGTH: 1423
 <212> TYPE: PRT
 <213> ORGANISM: Artificial Sequence
 <220> FEATURE:
 <223> OTHER INFORMATION: Description of Artificial Sequence: Synthetic
 polypeptide

<400> SEQUENCE: 50

Met Asp Tyr Lys Asp His Asp Gly Asp Tyr Lys Asp His Asp Ile Asp
 1 5 10 15

Tyr Lys Asp Asp Asp Asp Lys Met Ala Pro Lys Lys Lys Arg Lys Val
 20 25 30

Gly Ile His Gly Val Pro Ala Ala Asp Lys Lys Tyr Ser Ile Gly Leu
 35 40 45

Ala Ile Gly Thr Asn Ser Val Gly Trp Ala Val Ile Thr Asp Glu Tyr
 50 55 60

-continued

Lys Val Pro Ser Lys Lys Phe Lys Val Leu Gly Asn Thr Asp Arg His
 65 70 75 80
 Ser Ile Lys Lys Asn Leu Ile Gly Ala Leu Leu Phe Asp Ser Gly Glu
 85 90 95
 Thr Ala Glu Ala Thr Arg Leu Lys Arg Thr Ala Arg Arg Arg Tyr Thr
 100 105 110
 Arg Arg Lys Asn Arg Ile Cys Tyr Leu Gln Glu Ile Phe Ser Asn Glu
 115 120 125
 Met Ala Lys Val Asp Asp Ser Phe Phe His Arg Leu Glu Glu Ser Phe
 130 135 140
 Leu Val Glu Glu Asp Lys Lys His Glu Arg His Pro Ile Phe Gly Asn
 145 150 155 160
 Ile Val Asp Glu Val Ala Tyr His Glu Lys Tyr Pro Thr Ile Tyr His
 165 170 175
 Leu Arg Lys Lys Leu Val Asp Ser Thr Asp Lys Ala Asp Leu Arg Leu
 180 185 190
 Ile Tyr Leu Ala Leu Ala His Met Ile Lys Phe Arg Gly His Phe Leu
 195 200 205
 Ile Glu Gly Asp Leu Asn Pro Asp Asn Ser Asp Val Asp Lys Leu Phe
 210 215 220
 Ile Gln Leu Val Gln Thr Tyr Asn Gln Leu Phe Glu Glu Asn Pro Ile
 225 230 235 240
 Asn Ala Ser Gly Val Asp Ala Lys Ala Ile Leu Ser Ala Arg Leu Ser
 245 250 255
 Lys Ser Arg Arg Leu Glu Asn Leu Ile Ala Gln Leu Pro Gly Glu Lys
 260 265 270
 Lys Asn Gly Leu Phe Gly Asn Leu Ile Ala Leu Ser Leu Gly Leu Thr
 275 280 285
 Pro Asn Phe Lys Ser Asn Phe Asp Leu Ala Glu Asp Ala Lys Leu Gln
 290 295 300
 Leu Ser Lys Asp Thr Tyr Asp Asp Asp Leu Asp Asn Leu Leu Ala Gln
 305 310 315 320
 Ile Gly Asp Gln Tyr Ala Asp Leu Phe Leu Ala Ala Lys Asn Leu Ser
 325 330 335
 Asp Ala Ile Leu Leu Ser Asp Ile Leu Arg Val Asn Thr Glu Ile Thr
 340 345 350
 Lys Ala Pro Leu Ser Ala Ser Met Ile Lys Arg Tyr Asp Glu His His
 355 360 365
 Gln Asp Leu Thr Leu Leu Lys Ala Leu Val Arg Gln Gln Leu Pro Glu
 370 375 380
 Lys Tyr Lys Glu Ile Phe Phe Asp Gln Ser Lys Asn Gly Tyr Ala Gly
 385 390 395 400
 Tyr Ile Asp Gly Gly Ala Ser Gln Glu Glu Phe Tyr Lys Phe Ile Lys
 405 410 415
 Pro Ile Leu Glu Lys Met Asp Gly Thr Glu Glu Leu Leu Val Lys Leu
 420 425 430
 Asn Arg Glu Asp Leu Leu Arg Lys Gln Arg Thr Phe Asp Asn Gly Ser
 435 440 445
 Ile Pro His Gln Ile His Leu Gly Glu Leu His Ala Ile Leu Arg Arg
 450 455 460

-continued

Gln Glu Asp Phe Tyr Pro Phe Leu Lys Asp Asn Arg Glu Lys Ile Glu
 465 470 475 480
 Lys Ile Leu Thr Phe Arg Ile Pro Tyr Tyr Val Gly Pro Leu Ala Arg
 485 490 495
 Gly Asn Ser Arg Phe Ala Trp Met Thr Arg Lys Ser Glu Glu Thr Ile
 500 505 510
 Thr Pro Trp Asn Phe Glu Glu Val Val Asp Lys Gly Ala Ser Ala Gln
 515 520 525
 Ser Phe Ile Glu Arg Met Thr Asn Phe Asp Lys Asn Leu Pro Asn Glu
 530 535 540
 Lys Val Leu Pro Lys His Ser Leu Leu Tyr Glu Tyr Phe Thr Val Tyr
 545 550 555 560
 Asn Glu Leu Thr Lys Val Lys Tyr Val Thr Glu Gly Met Arg Lys Pro
 565 570 575
 Ala Phe Leu Ser Gly Glu Gln Lys Lys Ala Ile Val Asp Leu Leu Phe
 580 585 590
 Lys Thr Asn Arg Lys Val Thr Val Lys Gln Leu Lys Glu Asp Tyr Phe
 595 600 605
 Lys Lys Ile Glu Cys Phe Asp Ser Val Glu Ile Ser Gly Val Glu Asp
 610 615 620
 Arg Phe Asn Ala Ser Leu Gly Thr Tyr His Asp Leu Leu Lys Ile Ile
 625 630 635 640
 Lys Asp Lys Asp Phe Leu Asp Asn Glu Glu Asn Glu Asp Ile Leu Glu
 645 650 655
 Asp Ile Val Leu Thr Leu Thr Leu Phe Glu Asp Arg Glu Met Ile Glu
 660 665 670
 Glu Arg Leu Lys Thr Tyr Ala His Leu Phe Asp Asp Lys Val Met Lys
 675 680 685
 Gln Leu Lys Arg Arg Arg Tyr Thr Gly Trp Gly Arg Leu Ser Arg Lys
 690 695 700
 Leu Ile Asn Gly Ile Arg Asp Lys Gln Ser Gly Lys Thr Ile Leu Asp
 705 710 715 720
 Phe Leu Lys Ser Asp Gly Phe Ala Asn Arg Asn Phe Met Gln Leu Ile
 725 730 735
 His Asp Asp Ser Leu Thr Phe Lys Glu Asp Ile Gln Lys Ala Gln Val
 740 745 750
 Ser Gly Gln Gly Asp Ser Leu His Glu His Ile Ala Asn Leu Ala Gly
 755 760 765
 Ser Pro Ala Ile Lys Lys Gly Ile Leu Gln Thr Val Lys Val Val Asp
 770 775 780
 Glu Leu Val Lys Val Met Gly Arg His Lys Pro Glu Asn Ile Val Ile
 785 790 795 800
 Glu Met Ala Arg Glu Asn Gln Thr Thr Gln Lys Gly Gln Lys Asn Ser
 805 810 815
 Arg Glu Arg Met Lys Arg Ile Glu Glu Gly Ile Lys Glu Leu Gly Ser
 820 825 830
 Gln Ile Leu Lys Glu His Pro Val Glu Asn Thr Gln Leu Gln Asn Glu
 835 840 845
 Lys Leu Tyr Leu Tyr Tyr Leu Gln Asn Gly Arg Asp Met Tyr Val Asp
 850 855 860
 Gln Glu Leu Asp Ile Asn Arg Leu Ser Asp Tyr Asp Val Asp His Ile

-continued

865	870	875	880
Val Pro Gln Ser Phe Leu Lys Asp Asp Ser Ile Asp Asn Lys Val Leu	885	890	895
Thr Arg Ser Asp Lys Asn Arg Gly Lys Ser Asp Asn Val Pro Ser Glu	900	905	910
Glu Val Val Lys Lys Met Lys Asn Tyr Trp Arg Gln Leu Leu Asn Ala	915	920	925
Lys Leu Ile Thr Gln Arg Lys Phe Asp Asn Leu Thr Lys Ala Glu Arg	930	935	940
Gly Gly Leu Ser Glu Leu Asp Lys Ala Gly Phe Ile Lys Arg Gln Leu	945	950	955
Val Glu Thr Arg Gln Ile Thr Lys His Val Ala Gln Ile Leu Asp Ser	965	970	975
Arg Met Asn Thr Lys Tyr Asp Glu Asn Asp Lys Leu Ile Arg Glu Val	980	985	990
Lys Val Ile Thr Leu Lys Ser Lys Leu Val Ser Asp Phe Arg Lys Asp	995	1000	1005
Phe Gln Phe Tyr Lys Val Arg Glu Ile Asn Asn Tyr His His Ala	1010	1015	1020
His Asp Ala Tyr Leu Asn Ala Val Val Gly Thr Ala Leu Ile Lys	1025	1030	1035
Lys Tyr Pro Lys Leu Glu Ser Glu Phe Val Tyr Gly Asp Tyr Lys	1040	1045	1050
Val Tyr Asp Val Arg Lys Met Ile Ala Lys Ser Glu Gln Glu Ile	1055	1060	1065
Gly Lys Ala Thr Ala Lys Tyr Phe Phe Tyr Ser Asn Ile Met Asn	1070	1075	1080
Phe Phe Lys Thr Glu Ile Thr Leu Ala Asn Gly Glu Ile Arg Lys	1085	1090	1095
Arg Pro Leu Ile Glu Thr Asn Gly Glu Thr Gly Glu Ile Val Trp	1100	1105	1110
Asp Lys Gly Arg Asp Phe Ala Thr Val Arg Lys Val Leu Ser Met	1115	1120	1125
Pro Gln Val Asn Ile Val Lys Lys Thr Glu Val Gln Thr Gly Gly	1130	1135	1140
Phe Ser Lys Glu Ser Ile Leu Pro Lys Arg Asn Ser Asp Lys Leu	1145	1150	1155
Ile Ala Arg Lys Lys Asp Trp Asp Pro Lys Lys Tyr Gly Gly Phe	1160	1165	1170
Asp Ser Pro Thr Val Ala Tyr Ser Val Leu Val Val Ala Lys Val	1175	1180	1185
Glu Lys Gly Lys Ser Lys Lys Leu Lys Ser Val Lys Glu Leu Leu	1190	1195	1200
Gly Ile Thr Ile Met Glu Arg Ser Ser Phe Glu Lys Asn Pro Ile	1205	1210	1215
Asp Phe Leu Glu Ala Lys Gly Tyr Lys Glu Val Lys Lys Asp Leu	1220	1225	1230
Ile Ile Lys Leu Pro Lys Tyr Ser Leu Phe Glu Leu Glu Asn Gly	1235	1240	1245
Arg Lys Arg Met Leu Ala Ser Ala Gly Glu Leu Gln Lys Gly Asn	1250	1255	1260

-continued

Glu Leu Ala Leu Pro Ser Lys Tyr Val Asn Phe Leu Tyr Leu Ala
 1265 1270 1275
 Ser His Tyr Glu Lys Leu Lys Gly Ser Pro Glu Asp Asn Glu Gln
 1280 1285 1290
 Lys Gln Leu Phe Val Glu Gln His Lys His Tyr Leu Asp Glu Ile
 1295 1300 1305
 Ile Glu Gln Ile Ser Glu Phe Ser Lys Arg Val Ile Leu Ala Asp
 1310 1315 1320
 Ala Asn Leu Asp Lys Val Leu Ser Ala Tyr Asn Lys His Arg Asp
 1325 1330 1335
 Lys Pro Ile Arg Glu Gln Ala Glu Asn Ile Ile His Leu Phe Thr
 1340 1345 1350
 Leu Thr Asn Leu Gly Ala Pro Ala Ala Phe Lys Tyr Phe Asp Thr
 1355 1360 1365
 Thr Ile Asp Arg Lys Arg Tyr Thr Ser Thr Lys Glu Val Leu Asp
 1370 1375 1380
 Ala Thr Leu Ile His Gln Ser Ile Thr Gly Leu Tyr Glu Thr Arg
 1385 1390 1395
 Ile Asp Leu Ser Gln Leu Gly Gly Asp Lys Arg Pro Ala Ala Thr
 1400 1405 1410
 Lys Lys Ala Gly Gln Ala Lys Lys Lys Lys
 1415 1420

<210> SEQ ID NO 51

<211> LENGTH: 2012

<212> TYPE: DNA

<213> ORGANISM: Artificial Sequence

<220> FEATURE:

<223> OTHER INFORMATION: Description of Artificial Sequence: Synthetic polynucleotide

<400> SEQUENCE: 51

```

gaatgctgcc ctcagaccgc cttcctccct gtccttgtct gtccaaggag aatgaggtct    60
cactgggtgga tttcggacta ccttgaggag ctggcacctg agggacaagg cccccacct    120
gcccagctcc agcctctgat gaggggtggg agagagctac atgaggttgc taagaaagcc    180
tcccctgaag gagaccacac agtgtgtgag gttggagtct cttagcagcg gttctgtgcc    240
cccagggata gtctggctgt ccaggcactg ctcttgatat aaacaccacc tcctagtatt    300
gaaaccatgc ccattctgcc tctctgtatg gaaaagagca tggggctggc ccgtggggtg    360
gtgtccactt taggccctgt gggagatcat gggaaaccac gcagtgggtc ataggctctc    420
tcatttacta ctcacatcca ctctgtgaag aagcgattat gatctctcct ctagaaactc    480
gtagagtccc atgtctgcgc gcttcagag cctgcactcc tccacctgg cttggctttg    540
ctggggctag aggagctagg atgcacagca gctctgtgac cctttgtttg agaggaacag    600
gaaaaccacc cttctctctg gcccaactgt tcctcttctc gccctgcoat ccccttctgt    660
gaatgttaga cccatgggag cagctgggtca gaggggaccc cggcctgggg ccctaacc    720
tatgtagcct cagtcttccc atcaggctct cagctcagcc tgagtgttga ggccccagtg    780
gctgctctgg gggcctctg agtttctcat ctgtgcccct ccctccctgg cccaggtgaa    840
ggtgtggttc cagaaccgga ggacaaagta caaacggcag aagctggagg aggaagggcc    900
tgagtccgag cagaagaaga agggctccca tcacatcaac cgggtggcga ttgccacgaa    960

```

-continued

```

gcaggccaat ggggaggaca tcgatgtcac ctccaatgac aagcttgcta gcggtgggca 1020
accacaaaacc cacgagggca gactgctgct tgctgctggc caggcccctg cgtgggceca 1080
agctggactc tggccaactcc ctggccaggc ttggggagg cctggagtca tggccccaca 1140
gggcttgaag cccggggcgc ccattgacag agggacaagc aatgggctgg ctgaggcctg 1200
ggaccacttg gccttctcct cggagagcct gcctgectgg gcgggcccgc ccgccaccgc 1260
agcctcccag ctgctctcgc tgtctccaat ctcccttttg tttgatgca tttctgttt 1320
aatttatttt ccaggcacca ctgtagttta gtgatccca gtgtcccct tccctatggg 1380
aataataaaa gtctctctct taatgacacg ggcattccagc tccagccca gagcctgggg 1440
tggtagattc cggctctgag ggccagtggg ggctgtaga gcaaaccgt tcagggcctg 1500
ggagcctggg gtggggtact ggtggagggg gtcaagggtt attcattaac tctctcttt 1560
tgttggggga ccctggtctc tacctccagc tccacagcag gagaacagg ctagacatag 1620
ggaagggcca tcctgtatct tgagggagga caggcccagg tctttcttaa cgtattgaga 1680
ggtgggaatc agggccaggt agttcaatgg gagagggaga gtgcttccct ctgcctagag 1740
actctggtgg cttctccagt tgaggagaaa ccagaggaag ggggaggatt ggggtctggg 1800
ggaggggaaca ccattcaca aggctgacgg ttccagtcgc aagtcgtggg cccaccagga 1860
tgctcacctg tccttgagga accgctgggc aggttgagac tgcagagaca gggcttaag 1920
ctgagcctgc aaccagtccc cagtgactca ggcctcctc agccaagaa agagcaact 1980
gccagggccc gctgagctct tgtgttcacc tg 2012

```

<210> SEQ ID NO 52

<211> LENGTH: 1153

<212> TYPE: PRT

<213> ORGANISM: Artificial Sequence

<220> FEATURE:

<223> OTHER INFORMATION: Description of Artificial Sequence: Synthetic polypeptide

<400> SEQUENCE: 52

```

Met Lys Arg Pro Ala Ala Thr Lys Lys Ala Gly Gln Ala Lys Lys Lys
1           5           10          15
Lys Ser Asp Leu Val Leu Gly Leu Asp Ile Gly Ile Gly Ser Val Gly
20          25          30
Val Gly Ile Leu Asn Lys Val Thr Gly Glu Ile Ile His Lys Asn Ser
35          40          45
Arg Ile Phe Pro Ala Ala Gln Ala Glu Asn Asn Leu Val Arg Arg Thr
50          55          60
Asn Arg Gln Gly Arg Arg Leu Ala Arg Arg Lys Lys His Arg Arg Val
65          70          75          80
Arg Leu Asn Arg Leu Phe Glu Glu Ser Gly Leu Ile Thr Asp Phe Thr
85          90          95
Lys Ile Ser Ile Asn Leu Asn Pro Tyr Gln Leu Arg Val Lys Gly Leu
100         105         110
Thr Asp Glu Leu Ser Asn Glu Glu Leu Phe Ile Ala Leu Lys Asn Met
115        120        125
Val Lys His Arg Gly Ile Ser Tyr Leu Asp Asp Ala Ser Asp Asp Gly
130        135        140
Asn Ser Ser Val Gly Asp Tyr Ala Gln Ile Val Lys Glu Asn Ser Lys

```

-continued

145		150		155		160									
Gln	Leu	Glu	Thr	Lys	Thr	Pro	Gly	Gln	Ile	Gln	Leu	Glu	Arg	Tyr	Gln
				165					170						175
Thr	Tyr	Gly	Gln	Leu	Arg	Gly	Asp	Phe	Thr	Val	Glu	Lys	Asp	Gly	Lys
			180					185						190	
Lys	His	Arg	Leu	Ile	Asn	Val	Phe	Pro	Thr	Ser	Ala	Tyr	Arg	Ser	Glu
		195						200					205		
Ala	Leu	Arg	Ile	Leu	Gln	Thr	Gln	Gln	Glu	Phe	Asn	Pro	Gln	Ile	Thr
	210					215						220			
Asp	Glu	Phe	Ile	Asn	Arg	Tyr	Leu	Glu	Ile	Leu	Thr	Gly	Lys	Arg	Lys
225					230						235				240
Tyr	Tyr	His	Gly	Pro	Gly	Asn	Glu	Lys	Ser	Arg	Thr	Asp	Tyr	Gly	Arg
				245						250					255
Tyr	Arg	Thr	Ser	Gly	Glu	Thr	Leu	Asp	Asn	Ile	Phe	Gly	Ile	Leu	Ile
			260					265					270		
Gly	Lys	Cys	Thr	Phe	Tyr	Pro	Asp	Glu	Phe	Arg	Ala	Ala	Lys	Ala	Ser
		275						280				285			
Tyr	Thr	Ala	Gln	Glu	Phe	Asn	Leu	Leu	Asn	Asp	Leu	Asn	Asn	Leu	Thr
	290					295					300				
Val	Pro	Thr	Glu	Thr	Lys	Lys	Leu	Ser	Lys	Glu	Gln	Lys	Asn	Gln	Ile
305					310						315				320
Ile	Asn	Tyr	Val	Lys	Asn	Glu	Lys	Ala	Met	Gly	Pro	Ala	Lys	Leu	Phe
				325					330						335
Lys	Tyr	Ile	Ala	Lys	Leu	Leu	Ser	Cys	Asp	Val	Ala	Asp	Ile	Lys	Gly
			340					345					350		
Tyr	Arg	Ile	Asp	Lys	Ser	Gly	Lys	Ala	Glu	Ile	His	Thr	Phe	Glu	Ala
		355					360					365			
Tyr	Arg	Lys	Met	Lys	Thr	Leu	Glu	Thr	Leu	Asp	Ile	Glu	Gln	Met	Asp
	370					375					380				
Arg	Glu	Thr	Leu	Asp	Lys	Leu	Ala	Tyr	Val	Leu	Thr	Leu	Asn	Thr	Glu
385				390						395					400
Arg	Glu	Gly	Ile	Gln	Glu	Ala	Leu	Glu	His	Glu	Phe	Ala	Asp	Gly	Ser
			405						410						415
Phe	Ser	Gln	Lys	Gln	Val	Asp	Glu	Leu	Val	Gln	Phe	Arg	Lys	Ala	Asn
			420					425						430	
Ser	Ser	Ile	Phe	Gly	Lys	Gly	Trp	His	Asn	Phe	Ser	Val	Lys	Leu	Met
		435					440					445			
Met	Glu	Leu	Ile	Pro	Glu	Leu	Tyr	Glu	Thr	Ser	Glu	Glu	Gln	Met	Thr
	450					455					460				
Ile	Leu	Thr	Arg	Leu	Gly	Lys	Gln	Lys	Thr	Thr	Ser	Ser	Ser	Asn	Lys
465					470					475					480
Thr	Lys	Tyr	Ile	Asp	Glu	Lys	Leu	Leu	Thr	Glu	Glu	Ile	Tyr	Asn	Pro
			485						490						495
Val	Val	Ala	Lys	Ser	Val	Arg	Gln	Ala	Ile	Lys	Ile	Val	Asn	Ala	Ala
			500					505						510	
Ile	Lys	Glu	Tyr	Gly	Asp	Phe	Asp	Asn	Ile	Val	Ile	Glu	Met	Ala	Arg
		515					520					525			
Glu	Thr	Asn	Glu	Asp	Asp	Glu	Lys	Lys	Ala	Ile	Gln	Lys	Ile	Gln	Lys
	530						535				540				
Ala	Asn	Lys	Asp	Glu	Lys	Asp	Ala	Ala	Met	Leu	Lys	Ala	Ala	Asn	Gln
545					550					555					560

-continued

```

gagggcctat ttcccatgat tccttcatat ttgcatatac gatacaaggc tgtagagag      60
ataattggaa ttaatttgac tgtaaacaca aagatattag taaaaatac gtgacgtaga      120
aagtaataat ttcttgggta gtttgagtt ttaaaattat gttttaaata ggactatcat      180
atgcttacgc taacttgaaa gtatttcgat ttcttggcctt tataatctt gtggaagga      240
cgaaacacgc ggttttagag ctatgctgtt ttgaatggc ccaaacnnn nnnnnnnnnn      300
nnnnnnnnn nnnnnnngtt ttagagctat gctgtttga atggcccaa aactttttt      360

```

```

<210> SEQ ID NO 55
<211> LENGTH: 318
<212> TYPE: DNA
<213> ORGANISM: Artificial Sequence
<220> FEATURE:
<223> OTHER INFORMATION: Description of Artificial Sequence: Synthetic
      polynucleotide
<220> FEATURE:
<221> NAME/KEY: modified_base
<222> LOCATION: (250)..(269)
<223> OTHER INFORMATION: a, c, t, g, unknown or other

```

```

<400> SEQUENCE: 55

```

```

gagggcctat ttcccatgat tccttcatat ttgcatatac gatacaaggc tgtagagag      60
ataattggaa ttaatttgac tgtaaacaca aagatattag taaaaatac gtgacgtaga      120
aagtaataat ttcttgggta gtttgagtt ttaaaattat gttttaaata ggactatcat      180
atgcttacgc taacttgaaa gtatttcgat ttcttggcctt tataatctt gtggaagga      240
cgaaacacgc nnnnnnnnnn nnnnnnnnng ttttagagct agaaatagca agttaaata      300
aggctagtcc gttttttt      318

```

```

<210> SEQ ID NO 56
<211> LENGTH: 325
<212> TYPE: DNA
<213> ORGANISM: Artificial Sequence
<220> FEATURE:
<223> OTHER INFORMATION: Description of Artificial Sequence: Synthetic
      polynucleotide
<220> FEATURE:
<221> NAME/KEY: modified_base
<222> LOCATION: (250)..(269)
<223> OTHER INFORMATION: a, c, t, g, unknown or other

```

```

<400> SEQUENCE: 56

```

```

gagggcctat ttcccatgat tccttcatat ttgcatatac gatacaaggc tgtagagag      60
ataattggaa ttaatttgac tgtaaacaca aagatattag taaaaatac gtgacgtaga      120
aagtaataat ttcttgggta gtttgagtt ttaaaattat gttttaaata ggactatcat      180
atgcttacgc taacttgaaa gtatttcgat ttcttggcctt tataatctt gtggaagga      240
cgaaacacgc nnnnnnnnnn nnnnnnnnng ttttagagct agaaatagca agttaaata      300
aggctagtcc gttatcattt ttttt      325

```

```

<210> SEQ ID NO 57
<211> LENGTH: 337
<212> TYPE: DNA
<213> ORGANISM: Artificial Sequence
<220> FEATURE:
<223> OTHER INFORMATION: Description of Artificial Sequence: Synthetic
      polynucleotide
<220> FEATURE:

```

-continued

```

<221> NAME/KEY: modified_base
<222> LOCATION: (250)..(269)
<223> OTHER INFORMATION: a, c, t, g, unknown or other

<400> SEQUENCE: 57
gagggcctat ttcccatgat tccttcatat ttgcatatac gatacaaggc tgtagagag    60
ataattggaa ttaatttgac tgtaaacaca aagatattag tacaaaatac gtgacgtaga    120
aagtaataat ttcttgggta gtttgcagtt ttaaaattat gttttaaata ggactatcat    180
atgcttacog taacttgaaa gtatttcgat ttcttggcctt tatatatctt gtggaaagga    240
cgaaacaccc nnnnnnnnnn nnnnnnnnng ttttagagct agaaatagca agttaaata    300
aggctagtcc gttatcaact tgaaaagtg tttttttt    337

<210> SEQ ID NO 58
<211> LENGTH: 352
<212> TYPE: DNA
<213> ORGANISM: Artificial Sequence
<220> FEATURE:
<223> OTHER INFORMATION: Description of Artificial Sequence: Synthetic
      polynucleotide
<220> FEATURE:
<221> NAME/KEY: modified_base
<222> LOCATION: (250)..(269)
<223> OTHER INFORMATION: a, c, t, g, unknown or other

<400> SEQUENCE: 58
gagggcctat ttcccatgat tccttcatat ttgcatatac gatacaaggc tgtagagag    60
ataattggaa ttaatttgac tgtaaacaca aagatattag tacaaaatac gtgacgtaga    120
aagtaataat ttcttgggta gtttgcagtt ttaaaattat gttttaaata ggactatcat    180
atgcttacog taacttgaaa gtatttcgat ttcttggcctt tatatatctt gtggaaagga    240
cgaaacaccc nnnnnnnnnn nnnnnnnnng ttttagagct agaaatagca agttaaata    300
aggctagtcc gttatcaact tgaaaagtg gcaccgagtc ggtgcttttt tt    352

<210> SEQ ID NO 59
<211> LENGTH: 5101
<212> TYPE: DNA
<213> ORGANISM: Artificial Sequence
<220> FEATURE:
<223> OTHER INFORMATION: Description of Artificial Sequence: Synthetic
      polynucleotide

<400> SEQUENCE: 59
cgttacataa cttacggtaa atggcccgcc tggctgaccg cccaacgacc cccgccatt    60
gacgtcaata atgacgtatg ttcccatagt aacgccaata gggacttttc attgacgtca    120
atgggtggag tatttacggt aaactgcca cttggcagta catcaagtgt atcatatgcc    180
aagtacgccc cctattgacg tcaatgacgg taaatggccc gcctggcatt atgcccagta    240
catgacctta tgggactttc ctacttggca gtacatctac gtattagtca tcgctattac    300
catggtcgag gtgagcccca cgttctgctt cactctcccc atctcccccc cctccccacc    360
cccaattttg tatttattta ttttttaatt attttgtgca gcgatggggg cggggggggg    420
ggggggggcg gcgccaggcg gggcgggggc gggcgagggg cggggcgggg cgaggcggag    480
aggtcggcgc gcagccaatc agagcggcgc gctccgaaag tttcctttta tggcgaggcg    540
gcggcggcgg cggccctata aaaagcgaag cgcgcggcgg gcgggagtcg ctgcgacgct    600

```

-continued

gccttcgccc cgtgccccgc tccgccgccc cctcgcgccc cccgccccgg ctctgactga	660
ccgcgttact cccacagggt agcggggcggg acggcccttc tcctccgggc tgtaattagc	720
tgagcaagag gtaagggttt aagggatggt tggttggtgg ggtattaatg ttttaattacc	780
tggagcacct gcctgaaatc actttttttc aggttgacc ggtgccacca tggactataa	840
ggaccacgac ggagactaca aggatcatga tattgattac aaagacgatg acgataagat	900
ggccccaaag aagaagcggg aggtcgggat ccacggagtc ccagcagccc acaagaagta	960
cagcatcggc ctggacatcg gcaccaactc tgtgggctgg gccctgatca ccgacgagta	1020
caagtgcccc agcaagaat tcaagtgct gggcaacacc gaccggcaca gcatcaagaa	1080
gaacctgac ggagccctgc tgttcgacag cggcgaaaca gccgaggcca cccggctgaa	1140
gagaaccgcc agaagaagat acaccagacg gaagaaccgg atctgctatc tgcaagagat	1200
cttcagcaac gagatggcca aggtggacga cagcttcttc cacagactgg aagagtcctt	1260
cctggtggaa gagataaga agcagcagcg gcacccatc ttcggcaaca tcgtggacga	1320
ggtggcctac cacgagaagt accccacat ctaccacctg agaaagaac tggtgacag	1380
caccgacaag gccgacctgc ggtgatcta tctggccctg gccacatga tcaagttccg	1440
gggccaactc ctgatcgagg ggcacctgaa ccccgacaac agcgacgtgg acaagctgtt	1500
catccagctg gtgcagacct acaaccagct gttcgaggaa aaccccatca acgccagcgg	1560
cgtggacgcc aagccatcc tgtctgccag actgagcaag agcagacggc tggaaaaatc	1620
gatcggccag ctgcccggcg agaagaagaa tggcctgttc ggcaacctga ttgccctgag	1680
cctggcctg acccccaact tcaagagcaa cttcgacctg gccgaggatg ccaaactgca	1740
gctgagcaag gacacctacg acgacgacct ggacaacctg ctggcccaga tcggcgacca	1800
gtacgccgac ctgtttctgg ccgccaagaa cctgtccgac gccatcctgc tgagcgacat	1860
cctgagagtg aacaccgaga tcaccaaggc ccccctgagc gcctctatga tcaagagata	1920
cgacgagcac caccaggacc tgacctgct gaaagctctc gtgcggcagc agctgcctga	1980
gaagtacaaa gagattttct tcgaccagag caagaacggc tacgcccggc acattgacgg	2040
cggagccagc caggaagagt tctacaagtt catcaagccc atcctggaaa agatggacgg	2100
caccgaggaa ctgctctgta agctgaacag agaggacctg ctgcggaagc agcggacctt	2160
cgacaacggc agcatcccc accagatcca cctgggagag ctgcacgcca ttctgcggcg	2220
gcaggaagat ttttaccat tcctgaagga caaccgggaa aagatcgaga agatcctgac	2280
cttccgcatc ccctactacg tgggcctct ggcagggga aacagcagat tcgcctggat	2340
gaccagaaag agcgaggaaa ccatcaccoc ctggaacttc gaggaagtgg tggacaaggg	2400
cgcttccgcc cagagcttca tcgagcggat gaccaacttc gataagaacc tgcccaacga	2460
gaagtgctg cccaagcaca gcctgctgta cgagtacttc accgtgtata acgagctgac	2520
caaagtgaat tacgtgacgg agggaatgag aaagcccgcc ttcctgagcg gcgagcagaa	2580
aaaggccatc gtggacctgc tgttcaagac caaccggaaa gtgacctgta agcagctgaa	2640
agaggactac ttcaagaaaa tcgagtctt cgactccgtg gaaatctccg gcgtggaaga	2700
tcggttcaac gcctccctgg gcacatacca cgatctgctg aaaattatca aggacaagga	2760
cttccctggac aatgagggaaa acgaggacat tctggaagat atcgtgctga ccctgacact	2820
gtttgaggac agagagatga tcgaggaacg gctgaaaacc tatgcccacc tgttcgacga	2880

-continued

caaagtgatg aagcagctga agcggcggag atacaccggc tggggcaggc tgagccggaa	2940
gctgatcaac ggcacccggg acaagcagtc cggcaagaca atcctggatt tcctgaagtc	3000
cgacggcttc gccaacagaa acttcatgca gctgatccac gacgacagcc tgacctttaa	3060
agaggacatc cagaaagccc aggtgtccgg ccagggcgat agcctgcacg agcacattgc	3120
caatctggcc ggcagccccg ccattaagaa gggcatcctg cagacagtga aggtggtgga	3180
cgagctcgtg aaagtgatgg gccggcacia gcccgagaac atcgtgatcg aaatggccag	3240
agagaaccag accaccaga agggacagaa gaacagccgc gagagaatga agcggatcga	3300
agagggatc aaagagctgg gcagccagat cctgaaagaa caccocgtgg aaaacaccca	3360
gctgcagaac gagaagctgt acctgtacta cctgcagaat gggcgggata tgtacgtgga	3420
ccaggaactg gacatcaacc ggctgtccga ctacgatgtg gaccatatcg tgcctcagag	3480
ctttctgaag gacgactcca tcgacaacaa ggtgctgacc agaagcgaca agaaccgggg	3540
caagagcgac aacgtgcctc ccgaagaggt cgtgaagaag atgaagaact actggcggca	3600
gctgctgaac gccaaagtga ttaccagag aaagtctgac aatctgacca aggccgagag	3660
agggcgctg agcgaactgg ataagcccg cttcatcaag agacagctgg tggaaacccg	3720
gcagatcaca aagcacgtgg cacagatcct ggactcccg atgaacacta agtacgacga	3780
gaatgacaag ctgatccggg aagtgaaagt gatcacccctg aagtccaagc tgggtgtccga	3840
tttccggaag gatttccagt tttacaaagt gcgagagatc aacaactacc accacgcccc	3900
cgacgcctac ctgaacccg tcgtgggaac cgccctgac aaaaagtacc ctaagctgga	3960
aagcgagttc gtgtacggcg actacaaggt gtacgacgtg cggaaagtga tcgccaagag	4020
cgagcaggaa atcggcaagg ctaccgccc gtaacttctc tacagcaaca tcatgaactt	4080
tttcaagacc gagattaacc tggccaacgg cgagatccgg aagcggcctc tgatcgagac	4140
aaacggcgaa accggggaga tcgtgtggga taaggcccg gattttgcca ccgtgcggaa	4200
agtgtgagc atgccccaa tgaatatcgt gaaaaagacc gaggtgcaga caggcggctt	4260
cagcaaaagag tctatcctgc ccaagaggaa cagcgataag ctgatcgcca gaaagaagga	4320
ctgggaccct aagaagtacg gcggcttcca cagccccacc gtggcctatt ctgtgctggt	4380
ggtggccaaa gtgaaaaagg gcaagtocaa gaaactgaag agtgtgaaag agctgctggg	4440
gatcaccatc atggaaaaga gcagcttcca gaagaatccc atcgacttc tggaaagccaa	4500
gggctacaaa gaagtgaaaa aggacctgat catcaagctg cctaagtact ccctgttcca	4560
gctggaaaac ggcgggaaga gaatgctggc ctctgccggc gaactgcaga agggaaaacga	4620
actggccctg ccctccaaat atgtgaactt cctgtacctg gccagccact atgagaagct	4680
gaagggtcc cccgaggata atgagcagaa acagctgttt gtggaacagc acaagcacta	4740
cctggacgag atcatcgagc agatcagcga gttctccaag agagtgatcc tggccgacgc	4800
taatctggac aaagtgtgt ccgcctacaa caagcaccgg gataagccca tcagagagca	4860
ggccgagaat atcatccacc tgtttaccct gaccaatctg ggagcccctg ccgccttcaa	4920
gtactttgac accaccatcg accggaagag gtacaccagc accaaagagg tgctggacgc	4980
caccctgatc caccagagca tcaccggcct gtacgagaca cggatcgacc tgtctcagct	5040
gggagggcagc tttcttttct ttagcttgac cagctttctt agtagcagca ggacgcttta	5100
a	5101

-continued

<210> SEQ ID NO 60
<211> LENGTH: 137
<212> TYPE: DNA
<213> ORGANISM: Artificial Sequence
<220> FEATURE:
<223> OTHER INFORMATION: Description of Artificial Sequence: Synthetic polynucleotide
<220> FEATURE:
<221> NAME/KEY: modified_base
<222> LOCATION: (1)..(20)
<223> OTHER INFORMATION: a, c, t, g, unknown or other

<400> SEQUENCE: 60
nnnnnnnnnn nnnnnnnnnn gttattgtac tctcaagatt tagaaataaa tcttgcagaa 60
gctacaaaga taaggcttca tgccgaaatc aacaccctgt cattttatgg caggggtgtt 120
tcggtattta atttttt 137

<210> SEQ ID NO 61
<211> LENGTH: 123
<212> TYPE: DNA
<213> ORGANISM: Artificial Sequence
<220> FEATURE:
<223> OTHER INFORMATION: Description of Artificial Sequence: Synthetic polynucleotide
<220> FEATURE:
<221> NAME/KEY: modified_base
<222> LOCATION: (1)..(20)
<223> OTHER INFORMATION: a, c, t, g, unknown or other

<400> SEQUENCE: 61
nnnnnnnnnn nnnnnnnnnn gttattgtac tctcagaaat gcagaagcta caagataag 60
gcttcatgcc gaaatcaaca cctgtcatt ttatggcagg gtgttttcgt tattaattt 120
ttt 123

<210> SEQ ID NO 62
<211> LENGTH: 110
<212> TYPE: DNA
<213> ORGANISM: Artificial Sequence
<220> FEATURE:
<223> OTHER INFORMATION: Description of Artificial Sequence: Synthetic polynucleotide
<220> FEATURE:
<221> NAME/KEY: modified_base
<222> LOCATION: (1)..(20)
<223> OTHER INFORMATION: a, c, t, g, unknown or other

<400> SEQUENCE: 62
nnnnnnnnnn nnnnnnnnnn gttattgtac tctcagaaat gcagaagcta caagataag 60
gcttcatgcc gaaatcaaca cctgtcatt ttatggcagg gtgttttttt 110

<210> SEQ ID NO 63
<211> LENGTH: 137
<212> TYPE: DNA
<213> ORGANISM: Artificial Sequence
<220> FEATURE:
<223> OTHER INFORMATION: Description of Artificial Sequence: Synthetic polynucleotide
<220> FEATURE:
<221> NAME/KEY: modified_base
<222> LOCATION: (1)..(20)
<223> OTHER INFORMATION: a, c, t, g, unknown or other

<400> SEQUENCE: 63

-continued

nnnnnnnnnn nnnnnnnnnn gttattgtac tctcaagatt tagaaataaa tcttgcagaa 60
gctacaatga taaggcttca tgccgaaatc aacaccctgt cattttatgg caggggtgtt 120
tcggtattta atttttt 137

<210> SEQ ID NO 64
<211> LENGTH: 123
<212> TYPE: DNA
<213> ORGANISM: Artificial Sequence
<220> FEATURE:
<223> OTHER INFORMATION: Description of Artificial Sequence: Synthetic
polynucleotide
<220> FEATURE:
<221> NAME/KEY: modified_base
<222> LOCATION: (1)..(20)
<223> OTHER INFORMATION: a, c, t, g, unknown or other

<400> SEQUENCE: 64

nnnnnnnnnn nnnnnnnnnn gttattgtac tctcagaaat gcagaagcta caatgataag 60
gcttcatgcc gaaatcaaca cctgtcatt ttatggcagg gtgttttcgt tatttaattt 120
ttt 123

<210> SEQ ID NO 65
<211> LENGTH: 110
<212> TYPE: DNA
<213> ORGANISM: Artificial Sequence
<220> FEATURE:
<223> OTHER INFORMATION: Description of Artificial Sequence: Synthetic
polynucleotide
<220> FEATURE:
<221> NAME/KEY: modified_base
<222> LOCATION: (1)..(20)
<223> OTHER INFORMATION: a, c, t, g, unknown or other

<400> SEQUENCE: 65

nnnnnnnnnn nnnnnnnnnn gttattgtac tctcagaaat gcagaagcta caatgataag 60
gcttcatgcc gaaatcaaca cctgtcatt ttatggcagg gtgttttttt 110

<210> SEQ ID NO 66
<211> LENGTH: 107
<212> TYPE: DNA
<213> ORGANISM: Artificial Sequence
<220> FEATURE:
<223> OTHER INFORMATION: Description of Artificial Sequence: Synthetic
polynucleotide
<220> FEATURE:
<221> NAME/KEY: modified_base
<222> LOCATION: (1)..(20)
<223> OTHER INFORMATION: a, c, t, g, unknown or other

<400> SEQUENCE: 66

nnnnnnnnnn nnnnnnnnnn gtttagagc tgtggaaaca cagcgagtta aaataaggct 60
tagtccgtac tcaacttgaa aaggtggcac cgattcgggtg tttttt 107

<210> SEQ ID NO 67
<211> LENGTH: 4263
<212> TYPE: DNA
<213> ORGANISM: Artificial Sequence
<220> FEATURE:
<223> OTHER INFORMATION: Description of Artificial Sequence: Synthetic
polynucleotide

<400> SEQUENCE: 67

-continued

atgaaaaggc	cggcggccac	gaaaaaggcc	ggccaggcaa	aaaagaaaa	gaccaagccc	60
tacagcatcg	gcctggacat	cggcaccaat	agcgtgggct	gggccgtgac	caccgacaac	120
tacaagggtg	ccagcaagaa	aatgaagggtg	ctgggcaaca	cctccaagaa	gtacatcaag	180
aaaaacctgc	tgggctgtgct	gctgttcgac	agcggcatta	cagccgaggg	cagacggctg	240
aagagaaccg	ccagacggcg	gtacaccccg	cggagaaaca	gaatcctgta	tctgcaagag	300
atcttcagca	ccgagatggc	taccctggac	gacgccttct	tccagcggct	ggacgacagc	360
ttcctgggtg	ccgacgacaa	gcgggacagc	aagtacccca	tcttcggcaa	cctggtggaa	420
gagaaggcct	accacgacga	gttccccacc	atctaccacc	tgagaaaagta	cctggccgac	480
agcaccaaga	aggccgacct	gagactggtg	tatctggccc	tggccacat	gatcaagtac	540
cggggccact	tcctgatcga	ggcgaggtc	aacagcaaga	acaacgacat	ccagaagaac	600
ttccaggact	tcctggacac	ctacaacgcc	atcttcgaga	gcgacctgtc	cctggaaaac	660
agcaagcagc	tggaagagat	cgtgaaggac	aagatcagca	agctggaaaa	gaaggaccgc	720
atcctgaagc	tgttccccgg	cgagaagaac	agcggaatct	tcagcgagtt	tctgaagctg	780
atcgtgggca	accaggccga	cttcagaaaag	tgcttcaacc	tggacgagaa	agccagcctg	840
cacttcagca	aagagagcta	cgacgaggac	ctggaaaccc	tgctgggata	tatcggcgac	900
gactacagcg	acgtgttctc	gaaggccaag	aagctgtacg	acgctatcct	gctgagcggc	960
ttcctgacgg	tgaccgacaa	cgagacagag	gccccactga	gcagcggcat	gattaagcgg	1020
tacaacgagc	acaagagga	tctggctctg	ctgaaagagt	acatccggaa	catcagcctg	1080
aaaacctaca	atgaggtggt	caaggacgac	accaagaacg	gctacgcccgg	ctacatcgac	1140
ggcaagacca	accaggaaga	tttctatgtg	tacctgaaga	agctgctggc	cgagttcgag	1200
ggggccgact	actttctgga	aaaaatcgac	cgcgaggatt	tcctgcggaa	gcagcggacc	1260
ttcgacaacg	gcagcatccc	ctaccagatc	catctgcagg	aaatgcgggc	catcctggac	1320
aagcaggcca	agttctaccc	attcctggcc	aagaacaaag	agcggatcga	gaagatcctg	1380
accttccgca	tccttacta	cgtgggcccc	ctggccagag	gcaacagcga	ttttgcctgg	1440
tccatccgga	agcgaatga	gaagatcacc	ccctggaact	tcgaggacgt	gatcgacaaa	1500
gagtccagcg	ccgaggcctt	catcaaccgg	atgaccagct	tcgacctgta	cctgcccag	1560
gaaaagggtg	tgcccagca	cagcctgctg	tacgagacat	tcaatgtgta	taacgagctg	1620
accaaagtgc	ggtttatcgc	cgagtctatg	cgggactacc	agttcctgga	ctccaagcag	1680
aaaaaggaca	tcgtgcggct	gtacttcaag	gacaagcggg	aagtgaccga	taaggacatc	1740
atcgagtacc	tgacgcocat	ctacggctac	gatggcatcg	agctgaaggg	catcgagaag	1800
cagttcaact	ccagcctgag	cacataccac	gacctgctga	acattatcaa	cgacaaagaa	1860
tttctggacg	actccagcaa	cgaggccatc	atcgaagaga	tcatccacac	cctgaccatc	1920
tttgaggacc	gcgagatgat	caagcagcgg	ctgagcaagt	tcgagaacat	cttcgacaag	1980
agcgtgctga	aaaagctgag	cagacggcac	tacaccggct	ggggcaagct	gagcgccaag	2040
ctgatcaacg	gcattccggga	cgagaagtcc	ggcaacacaa	tcctggacta	cctgatcgac	2100
gacggcatca	gcaaccggaa	cttcatgcag	ctgatccacg	acgacgccct	gagcttcaag	2160
aagaagatcc	agaaggccca	gatcatcggg	gacgaggaca	agggcaacat	caaagaagtc	2220
gtgaagtccc	tgcccggcag	ccccgccatc	aagaagggaa	tcctgcagag	catcaagatc	2280

-continued

gtggacgagc tcgtgaaagt gatggcggc agaaagccc agagcatcgt ggtggaatg	2340
gctagagaga accagtacac caatcagggc aagagcaaca gccagcagag actgaagaga	2400
ctggaaaagt ccctgaaaga gctggcgagc aagattctga aagagaatat cctgccaag	2460
ctgtccaaga tcgacaacaa cgccctgcag aacgaccggc tgtacctgta ctacctgcag	2520
aatggcaagg acatgtatac aggcgacgac ctggatatcg accgcctgag caactacgac	2580
atcgaccata ttatcccca gcccttctg aaagacaaca gcattgacaa caaagtgctg	2640
gtgtcctcgg ccagcaaccg cggcaagtcc gatgatgtgc ccagcctgga agtcgtgaaa	2700
aagagaaaaga ccttctggtg tcagctgctg aaaagcaagc tgattagcca gaggaagttc	2760
gacaacctga ccaaggccga gagaggcggc ctgagccctg aagataaggc cggcttcatc	2820
cagagacagc tgggtgaaac ccggcagatc accaagcacg tggccagact gctggatgag	2880
aagtttaaca acaagaagga cgagaacaac cgggcccgtc ggaccgtgaa gatcatcacc	2940
ctgaagtcca ccctggtgtc ccagttccgg aaggacttcc agctgtataa agtgcgagag	3000
atcaatgact ttcaccaacg ccacgacgcc tacctgaatg ccgtggtggc ttcgcctcgt	3060
ctgaagaagt accctaagct ggaaccggag ttcgtgtacg gcgactacc caagtacaac	3120
tccttcagag agcgggaagtc cggccaggag aagggtgact tctactcca catcatgaat	3180
atctttaaga agtccatctc cctggccgat ggcagagtga tcgagcggcc cctgatcgaa	3240
gtgaacgaag agacaggcga gagcgtgtgg aacaagaaa gcgacctggc caccgtgagg	3300
cgggtgctga gttatctca agtgaatgtc gtgaagaagg tggagaaca gaaccacggc	3360
ctggatcggg gcaagcccaa gggcctgttc aacgccaacc tgtccagcaa gcctaagccc	3420
aactccaacg agaatctcgt gggggccaaa gactacctgg accctaagaa gtacggcggg	3480
tacgcccgca tctccaatag cttcacctgt ctcgtgaagg gcacaatcga gaagggcgct	3540
aagaaaaaga tcacaaacgt gctggaattt caggggatct ctatcctgga ccggatcaac	3600
taccggaagg ataagctgaa ctttctgctg gaaaaaggct acaaggacat tgagctgatt	3660
atcgagctgc ctaagtactc cctgttcgaa ctgagcgcag gctccagacg gatgctggcc	3720
tccatcctgt ccaccaacaa caagcggggc gagatccaca agggaaacca gatcttctcgt	3780
agccagaaat ttgtgaaact gctgtaccac gccaaaggga tctccaacac catcaatgag	3840
aaccaccgga aatacgtgga aaaccacaag aaagagtttg aggaaactgt ctactacatc	3900
ctggagttea acgagaacta tgtgggagcc aagaagaacg gcaaactgct gaactccgcc	3960
ttccagagct ggcagaacca cagcatcgac gagctgtgca gctccttcat cggccctacc	4020
ggcagcagc ggaagggact gtttgagctg acctccagag gctctgccgc cgactttgag	4080
ttcctgggag tgaagatccc ccggtacaga gactacacc cctctagtct gctgaaggac	4140
gccaccctga tccaccagag cgtgaccggc ctgtacgaaa cccggatcga cctggctaag	4200
ctggcgagg gaaagcgtcc tgetctact aagaaagctg gtcaagctaa gaaaaagaaa	4260
taa	4263

<210> SEQ ID NO 68

<211> LENGTH: 53

<212> TYPE: DNA

<213> ORGANISM: Artificial Sequence

<220> FEATURE:

<223> OTHER INFORMATION: Description of Artificial Sequence: Synthetic primer

-continued

<400> SEQUENCE: 68

tcctagcagg atttctgata ttactgtcac gttttagagc tatgetgttt tga 53

<210> SEQ ID NO 69

<211> LENGTH: 53

<212> TYPE: DNA

<213> ORGANISM: Artificial Sequence

<220> FEATURE:

<223> OTHER INFORMATION: Description of Artificial Sequence: Synthetic primer

<400> SEQUENCE: 69

gtgacagtaa tatcagaaat cctgctagga gttttgggac cattcaaac agc 53

<210> SEQ ID NO 70

<211> LENGTH: 25

<212> TYPE: DNA

<213> ORGANISM: Artificial Sequence

<220> FEATURE:

<223> OTHER INFORMATION: Description of Artificial Sequence: Synthetic primer

<400> SEQUENCE: 70

gggtttcaag tcctttagc aagag 25

<210> SEQ ID NO 71

<211> LENGTH: 24

<212> TYPE: DNA

<213> ORGANISM: Artificial Sequence

<220> FEATURE:

<223> OTHER INFORMATION: Description of Artificial Sequence: Synthetic primer

<400> SEQUENCE: 71

gccaatgaac ggaaccctt ggtc 24

<210> SEQ ID NO 72

<211> LENGTH: 25

<212> TYPE: DNA

<213> ORGANISM: Artificial Sequence

<220> FEATURE:

<223> OTHER INFORMATION: Description of Artificial Sequence: Synthetic primer

<220> FEATURE:

<221> NAME/KEY: modified_base

<222> LOCATION: (1)..(4)

<223> OTHER INFORMATION: a, c, t, g, unknown or other

<400> SEQUENCE: 72

nnnngacgag gcaatggctg aaatc 25

<210> SEQ ID NO 73

<211> LENGTH: 25

<212> TYPE: DNA

<213> ORGANISM: Artificial Sequence

<220> FEATURE:

<223> OTHER INFORMATION: Description of Artificial Sequence: Synthetic primer

<220> FEATURE:

<221> NAME/KEY: modified_base

<222> LOCATION: (1)..(4)

<223> OTHER INFORMATION: a, c, t, g, unknown or other

<400> SEQUENCE: 73

-continued

nnnnttattt ggctcatatt tgctg 25

<210> SEQ ID NO 74
<211> LENGTH: 25
<212> TYPE: DNA
<213> ORGANISM: Artificial Sequence
<220> FEATURE:
<223> OTHER INFORMATION: Description of Artificial Sequence: Synthetic
primer

<400> SEQUENCE: 74

ctttacacca atcgctgcaa cagac 25

<210> SEQ ID NO 75
<211> LENGTH: 45
<212> TYPE: DNA
<213> ORGANISM: Artificial Sequence
<220> FEATURE:
<223> OTHER INFORMATION: Description of Artificial Sequence: Synthetic
primer

<400> SEQUENCE: 75

caaaatttct agtcttcttt gcctttcccc ataaaacct cctta 45

<210> SEQ ID NO 76
<211> LENGTH: 45
<212> TYPE: DNA
<213> ORGANISM: Artificial Sequence
<220> FEATURE:
<223> OTHER INFORMATION: Description of Artificial Sequence: Synthetic
primer

<400> SEQUENCE: 76

agggttttat ggggaaaggc aaagaagact agaaattttg atacc 45

<210> SEQ ID NO 77
<211> LENGTH: 25
<212> TYPE: DNA
<213> ORGANISM: Artificial Sequence
<220> FEATURE:
<223> OTHER INFORMATION: Description of Artificial Sequence: Synthetic
primer

<400> SEQUENCE: 77

cttacggtgc ataaagtcaa ttcc 25

<210> SEQ ID NO 78
<211> LENGTH: 21
<212> TYPE: DNA
<213> ORGANISM: Artificial Sequence
<220> FEATURE:
<223> OTHER INFORMATION: Description of Artificial Sequence: Synthetic
primer

<400> SEQUENCE: 78

tggtcgcatt tcagccattg c 21

<210> SEQ ID NO 79
<211> LENGTH: 43
<212> TYPE: DNA
<213> ORGANISM: Artificial Sequence
<220> FEATURE:
<223> OTHER INFORMATION: Description of Artificial Sequence: Synthetic
primer
<220> FEATURE:

-continued

<221> NAME/KEY: modified_base
<222> LOCATION: (33)..(33)
<223> OTHER INFORMATION: a, c, t, g, unknown or other

<400> SEQUENCE: 79

ctttgacgag gcaatggctg aaatcgagcc aanaagcgc aag 43

<210> SEQ ID NO 80
<211> LENGTH: 43
<212> TYPE: DNA
<213> ORGANISM: Artificial Sequence
<220> FEATURE:
<223> OTHER INFORMATION: Description of Artificial Sequence: Synthetic primer
<220> FEATURE:
<221> NAME/KEY: modified_base
<222> LOCATION: (34)..(34)
<223> OTHER INFORMATION: a, c, t, g, unknown or other

<400> SEQUENCE: 80

ctttgacgag gcaatggctg aaatcgagcc aanaagcgc aag 43

<210> SEQ ID NO 81
<211> LENGTH: 43
<212> TYPE: DNA
<213> ORGANISM: Artificial Sequence
<220> FEATURE:
<223> OTHER INFORMATION: Description of Artificial Sequence: Synthetic primer
<220> FEATURE:
<221> NAME/KEY: modified_base
<222> LOCATION: (35)..(35)
<223> OTHER INFORMATION: a, c, t, g, unknown or other

<400> SEQUENCE: 81

ctttgacgag gcaatggctg aaatcgagcc aanaagcgc aag 43

<210> SEQ ID NO 82
<211> LENGTH: 43
<212> TYPE: DNA
<213> ORGANISM: Artificial Sequence
<220> FEATURE:
<223> OTHER INFORMATION: Description of Artificial Sequence: Synthetic primer
<220> FEATURE:
<221> NAME/KEY: modified_base
<222> LOCATION: (36)..(36)
<223> OTHER INFORMATION: a, c, t, g, unknown or other

<400> SEQUENCE: 82

ctttgacgag gcaatggctg aaatcgagcc aanaagcgc aag 43

<210> SEQ ID NO 83
<211> LENGTH: 43
<212> TYPE: DNA
<213> ORGANISM: Artificial Sequence
<220> FEATURE:
<223> OTHER INFORMATION: Description of Artificial Sequence: Synthetic primer
<220> FEATURE:
<221> NAME/KEY: modified_base
<222> LOCATION: (37)..(37)
<223> OTHER INFORMATION: a, c, t, g, unknown or other

<400> SEQUENCE: 83

ctttgacgag gcaatggctg aaatcgagcc aanaagcgc aag 43

-continued

<210> SEQ ID NO 84
<211> LENGTH: 43
<212> TYPE: DNA
<213> ORGANISM: Artificial Sequence
<220> FEATURE:
<223> OTHER INFORMATION: Description of Artificial Sequence: Synthetic
primer
<220> FEATURE:
<221> NAME/KEY: modified_base
<222> LOCATION: (38)..(38)
<223> OTHER INFORMATION: a, c, t, g, unknown or other

<400> SEQUENCE: 84

ctttgacgag gcaatggctg aaatcgagcc aaaaaagngc aag 43

<210> SEQ ID NO 85
<211> LENGTH: 46
<212> TYPE: DNA
<213> ORGANISM: Artificial Sequence
<220> FEATURE:
<223> OTHER INFORMATION: Description of Artificial Sequence: Synthetic
primer
<220> FEATURE:
<221> NAME/KEY: modified_base
<222> LOCATION: (39)..(39)
<223> OTHER INFORMATION: a, c, t, g, unknown or other

<400> SEQUENCE: 85

ctttgacgag gcaatggctg aaatcgagcc aaaaaagcnc aagaag 46

<210> SEQ ID NO 86
<211> LENGTH: 46
<212> TYPE: DNA
<213> ORGANISM: Artificial Sequence
<220> FEATURE:
<223> OTHER INFORMATION: Description of Artificial Sequence: Synthetic
primer
<220> FEATURE:
<221> NAME/KEY: modified_base
<222> LOCATION: (40)..(40)
<223> OTHER INFORMATION: a, c, t, g, unknown or other

<400> SEQUENCE: 86

ctttgacgag gcaatggctg aaatcgagcc aaaaaagcgn aagaag 46

<210> SEQ ID NO 87
<211> LENGTH: 46
<212> TYPE: DNA
<213> ORGANISM: Artificial Sequence
<220> FEATURE:
<223> OTHER INFORMATION: Description of Artificial Sequence: Synthetic
primer
<220> FEATURE:
<221> NAME/KEY: modified_base
<222> LOCATION: (41)..(41)
<223> OTHER INFORMATION: a, c, t, g, unknown or other

<400> SEQUENCE: 87

ctttgacgag gcaatggctg aaatcgagcc aaaaaagcgc nagaag 46

<210> SEQ ID NO 88
<211> LENGTH: 23
<212> TYPE: DNA
<213> ORGANISM: Artificial Sequence
<220> FEATURE:
<223> OTHER INFORMATION: Description of Artificial Sequence: Synthetic
primer

-continued

<400> SEQUENCE: 88

gcgctttttt ggctcgattt cag 23

<210> SEQ ID NO 89

<211> LENGTH: 40

<212> TYPE: DNA

<213> ORGANISM: Artificial Sequence

<220> FEATURE:

<223> OTHER INFORMATION: Description of Artificial Sequence: Synthetic primer

<220> FEATURE:

<221> NAME/KEY: modified_base

<222> LOCATION: (31)..(31)

<223> OTHER INFORMATION: a, c, t, g, unknown or other

<400> SEQUENCE: 89

caatggctga aatcgagcca aaaaagcgca ngaagaaatc 40

<210> SEQ ID NO 90

<211> LENGTH: 40

<212> TYPE: DNA

<213> ORGANISM: Artificial Sequence

<220> FEATURE:

<223> OTHER INFORMATION: Description of Artificial Sequence: Synthetic primer

<220> FEATURE:

<221> NAME/KEY: modified_base

<222> LOCATION: (32)..(32)

<223> OTHER INFORMATION: a, c, t, g, unknown or other

<400> SEQUENCE: 90

caatggctga aatcgagcca aaaaagcgca anaagaaatc 40

<210> SEQ ID NO 91

<211> LENGTH: 40

<212> TYPE: DNA

<213> ORGANISM: Artificial Sequence

<220> FEATURE:

<223> OTHER INFORMATION: Description of Artificial Sequence: Synthetic primer

<220> FEATURE:

<221> NAME/KEY: modified_base

<222> LOCATION: (33)..(33)

<223> OTHER INFORMATION: a, c, t, g, unknown or other

<400> SEQUENCE: 91

caatggctga aatcgagcca aaaaagcgca agnagaaatc 40

<210> SEQ ID NO 92

<211> LENGTH: 40

<212> TYPE: DNA

<213> ORGANISM: Artificial Sequence

<220> FEATURE:

<223> OTHER INFORMATION: Description of Artificial Sequence: Synthetic primer

<220> FEATURE:

<221> NAME/KEY: modified_base

<222> LOCATION: (34)..(34)

<223> OTHER INFORMATION: a, c, t, g, unknown or other

<400> SEQUENCE: 92

caatggctga aatcgagcca aaaaagcgca agangaaatc 40

<210> SEQ ID NO 93

<211> LENGTH: 40

-continued

<212> TYPE: DNA
<213> ORGANISM: Artificial Sequence
<220> FEATURE:
<223> OTHER INFORMATION: Description of Artificial Sequence: Synthetic
primer
<220> FEATURE:
<221> NAME/KEY: modified_base
<222> LOCATION: (35)..(35)
<223> OTHER INFORMATION: a, c, t, g, unknown or other

<400> SEQUENCE: 93

caatggctga aatcgagcca aaaaagcgca agaanaaatc 40

<210> SEQ ID NO 94
<211> LENGTH: 44
<212> TYPE: DNA
<213> ORGANISM: Artificial Sequence
<220> FEATURE:
<223> OTHER INFORMATION: Description of Artificial Sequence: Synthetic
primer
<220> FEATURE:
<221> NAME/KEY: modified_base
<222> LOCATION: (36)..(36)
<223> OTHER INFORMATION: a, c, t, g, unknown or other

<400> SEQUENCE: 94

caatggctga aatcgagcca aaaaagcgca agaagnaatc aacc 44

<210> SEQ ID NO 95
<211> LENGTH: 44
<212> TYPE: DNA
<213> ORGANISM: Artificial Sequence
<220> FEATURE:
<223> OTHER INFORMATION: Description of Artificial Sequence: Synthetic
primer
<220> FEATURE:
<221> NAME/KEY: modified_base
<222> LOCATION: (37)..(37)
<223> OTHER INFORMATION: a, c, t, g, unknown or other

<400> SEQUENCE: 95

caatggctga aatcgagcca aaaaagcgca agaaganatc aacc 44

<210> SEQ ID NO 96
<211> LENGTH: 44
<212> TYPE: DNA
<213> ORGANISM: Artificial Sequence
<220> FEATURE:
<223> OTHER INFORMATION: Description of Artificial Sequence: Synthetic
primer
<220> FEATURE:
<221> NAME/KEY: modified_base
<222> LOCATION: (38)..(38)
<223> OTHER INFORMATION: a, c, t, g, unknown or other

<400> SEQUENCE: 96

caatggctga aatcgagcca aaaaagcgca agaagaantc aacc 44

<210> SEQ ID NO 97
<211> LENGTH: 44
<212> TYPE: DNA
<213> ORGANISM: Artificial Sequence
<220> FEATURE:
<223> OTHER INFORMATION: Description of Artificial Sequence: Synthetic
primer
<220> FEATURE:
<221> NAME/KEY: modified_base
<222> LOCATION: (39)..(39)

-continued

<223> OTHER INFORMATION: a, c, t, g, unknown or other

<400> SEQUENCE: 97

caatggctga aatcgagcca aaaaagcgca agaagaaanc aacc 44

<210> SEQ ID NO 98
<211> LENGTH: 47
<212> TYPE: DNA
<213> ORGANISM: Artificial Sequence
<220> FEATURE:
<223> OTHER INFORMATION: Description of Artificial Sequence: Synthetic primer
<220> FEATURE:
<221> NAME/KEY: modified_base
<222> LOCATION: (40)..(40)
<223> OTHER INFORMATION: a, c, t, g, unknown or other

<400> SEQUENCE: 98

caatggctga aatcgagcca aaaaagcgca agaagaaatn aaccagc 47

<210> SEQ ID NO 99
<211> LENGTH: 47
<212> TYPE: DNA
<213> ORGANISM: Artificial Sequence
<220> FEATURE:
<223> OTHER INFORMATION: Description of Artificial Sequence: Synthetic primer
<220> FEATURE:
<221> NAME/KEY: modified_base
<222> LOCATION: (41)..(41)
<223> OTHER INFORMATION: a, c, t, g, unknown or other

<400> SEQUENCE: 99

caatggctga aatcgagcca aaaaagcgca agaagaaatc naccagc 47

<210> SEQ ID NO 100
<211> LENGTH: 31
<212> TYPE: DNA
<213> ORGANISM: Artificial Sequence
<220> FEATURE:
<223> OTHER INFORMATION: Description of Artificial Sequence: Synthetic primer

<400> SEQUENCE: 100

gatcctccat ccgtacaacc cacaaccctg g 31

<210> SEQ ID NO 101
<211> LENGTH: 31
<212> TYPE: DNA
<213> ORGANISM: Artificial Sequence
<220> FEATURE:
<223> OTHER INFORMATION: Description of Artificial Sequence: Synthetic primer

<400> SEQUENCE: 101

aattccaggg ttgtgggttg tacggatgga g 31

<210> SEQ ID NO 102
<211> LENGTH: 34
<212> TYPE: DNA
<213> ORGANISM: Artificial Sequence
<220> FEATURE:
<223> OTHER INFORMATION: Description of Artificial Sequence: Synthetic primer

<400> SEQUENCE: 102

-continued

catggatcct atttcttaat aactaaaaat atgg 34

<210> SEQ ID NO 103
<211> LENGTH: 33
<212> TYPE: DNA
<213> ORGANISM: Artificial Sequence
<220> FEATURE:
<223> OTHER INFORMATION: Description of Artificial Sequence: Synthetic
primer

<400> SEQUENCE: 103

catgaattca actcaacaag tctcagtgctg 33

<210> SEQ ID NO 104
<211> LENGTH: 35
<212> TYPE: DNA
<213> ORGANISM: Artificial Sequence
<220> FEATURE:
<223> OTHER INFORMATION: Description of Artificial Sequence: Synthetic
primer

<400> SEQUENCE: 104

aaacattttt tctccattta ggaaaaagga tgctg 35

<210> SEQ ID NO 105
<211> LENGTH: 35
<212> TYPE: DNA
<213> ORGANISM: Artificial Sequence
<220> FEATURE:
<223> OTHER INFORMATION: Description of Artificial Sequence: Synthetic
primer

<400> SEQUENCE: 105

aaaacagcat ccttttctct aaatggagaa aaaat 35

<210> SEQ ID NO 106
<211> LENGTH: 35
<212> TYPE: DNA
<213> ORGANISM: Artificial Sequence
<220> FEATURE:
<223> OTHER INFORMATION: Description of Artificial Sequence: Synthetic
primer

<400> SEQUENCE: 106

aaaccttaaa tcagtcacaa atagcagcaa aattg 35

<210> SEQ ID NO 107
<211> LENGTH: 35
<212> TYPE: DNA
<213> ORGANISM: Artificial Sequence
<220> FEATURE:
<223> OTHER INFORMATION: Description of Artificial Sequence: Synthetic
primer

<400> SEQUENCE: 107

aaaacaattt tgctgctatt tgtgactgat ttaag 35

<210> SEQ ID NO 108
<211> LENGTH: 35
<212> TYPE: DNA
<213> ORGANISM: Artificial Sequence
<220> FEATURE:
<223> OTHER INFORMATION: Description of Artificial Sequence: Synthetic
primer

-continued

<400> SEQUENCE: 108

aaacttttca tcatacgacc aatctgcttt atttg 35

<210> SEQ ID NO 109

<211> LENGTH: 35

<212> TYPE: DNA

<213> ORGANISM: Artificial Sequence

<220> FEATURE:

<223> OTHER INFORMATION: Description of Artificial Sequence: Synthetic primer

<400> SEQUENCE: 109

aaaacaaata aagcagattg gtcgtatgat gaaaa 35

<210> SEQ ID NO 110

<211> LENGTH: 35

<212> TYPE: DNA

<213> ORGANISM: Artificial Sequence

<220> FEATURE:

<223> OTHER INFORMATION: Description of Artificial Sequence: Synthetic primer

<400> SEQUENCE: 110

aaactcgtcc agaagttatc gtaaaagaaa tcgag 35

<210> SEQ ID NO 111

<211> LENGTH: 35

<212> TYPE: DNA

<213> ORGANISM: Artificial Sequence

<220> FEATURE:

<223> OTHER INFORMATION: Description of Artificial Sequence: Synthetic primer

<400> SEQUENCE: 111

aaaactcgat ttcttttacg ataacttctg gacga 35

<210> SEQ ID NO 112

<211> LENGTH: 35

<212> TYPE: DNA

<213> ORGANISM: Artificial Sequence

<220> FEATURE:

<223> OTHER INFORMATION: Description of Artificial Sequence: Synthetic primer

<400> SEQUENCE: 112

aaacaatctc tccaagggtt ccttaaaaat ctctg 35

<210> SEQ ID NO 113

<211> LENGTH: 35

<212> TYPE: DNA

<213> ORGANISM: Artificial Sequence

<220> FEATURE:

<223> OTHER INFORMATION: Description of Artificial Sequence: Synthetic primer

<400> SEQUENCE: 113

aaaacagaga tttttaagga aaccttgag agatt 35

<210> SEQ ID NO 114

<211> LENGTH: 35

<212> TYPE: DNA

<213> ORGANISM: Artificial Sequence

<220> FEATURE:

-continued

<223> OTHER INFORMATION: Description of Artificial Sequence: Synthetic primer

<400> SEQUENCE: 114

aaacgccatc gtcaggaaga agctatgctt gagtg 35

<210> SEQ ID NO 115
<211> LENGTH: 35
<212> TYPE: DNA
<213> ORGANISM: Artificial Sequence
<220> FEATURE:
<223> OTHER INFORMATION: Description of Artificial Sequence: Synthetic primer

<400> SEQUENCE: 115

aaaacactca agcatagctt cttcctgacg atggc 35

<210> SEQ ID NO 116
<211> LENGTH: 35
<212> TYPE: DNA
<213> ORGANISM: Artificial Sequence
<220> FEATURE:
<223> OTHER INFORMATION: Description of Artificial Sequence: Synthetic primer

<400> SEQUENCE: 116

aaacatctct atacttattg aaatttcttt gtatg 35

<210> SEQ ID NO 117
<211> LENGTH: 35
<212> TYPE: DNA
<213> ORGANISM: Artificial Sequence
<220> FEATURE:
<223> OTHER INFORMATION: Description of Artificial Sequence: Synthetic primer

<400> SEQUENCE: 117

aaaacataca aagaaatttc aataagtata gagat 35

<210> SEQ ID NO 118
<211> LENGTH: 35
<212> TYPE: DNA
<213> ORGANISM: Artificial Sequence
<220> FEATURE:
<223> OTHER INFORMATION: Description of Artificial Sequence: Synthetic primer

<400> SEQUENCE: 118

aaactagctg tgatagtccg caaaaccagc cttcg 35

<210> SEQ ID NO 119
<211> LENGTH: 35
<212> TYPE: DNA
<213> ORGANISM: Artificial Sequence
<220> FEATURE:
<223> OTHER INFORMATION: Description of Artificial Sequence: Synthetic primer

<400> SEQUENCE: 119

aaaacgaagg ctggttttgc ggactatcac agcta 35

<210> SEQ ID NO 120
<211> LENGTH: 35
<212> TYPE: DNA

-continued

<213> ORGANISM: Artificial Sequence
<220> FEATURE:
<223> OTHER INFORMATION: Description of Artificial Sequence: Synthetic primer

<400> SEQUENCE: 120
aaacatcgga aggtcgagca agtaattatc ttttg 35

<210> SEQ ID NO 121
<211> LENGTH: 35
<212> TYPE: DNA
<213> ORGANISM: Artificial Sequence
<220> FEATURE:
<223> OTHER INFORMATION: Description of Artificial Sequence: Synthetic primer

<400> SEQUENCE: 121
aaaacaaaag ataattactt gctcgacctt ccgat 35

<210> SEQ ID NO 122
<211> LENGTH: 35
<212> TYPE: DNA
<213> ORGANISM: Artificial Sequence
<220> FEATURE:
<223> OTHER INFORMATION: Description of Artificial Sequence: Synthetic primer

<400> SEQUENCE: 122
aaacaagatg gtatcgcaaa gtaagtgaca ataag 35

<210> SEQ ID NO 123
<211> LENGTH: 35
<212> TYPE: DNA
<213> ORGANISM: Artificial Sequence
<220> FEATURE:
<223> OTHER INFORMATION: Description of Artificial Sequence: Synthetic primer

<400> SEQUENCE: 123
aaaacttatt gtcacttact ttgcgatacc atctt 35

<210> SEQ ID NO 124
<211> LENGTH: 52
<212> TYPE: DNA
<213> ORGANISM: Artificial Sequence
<220> FEATURE:
<223> OTHER INFORMATION: Description of Artificial Sequence: Synthetic primer

<400> SEQUENCE: 124
gagacctttg agcttccgag actggtctca gttttgggac cattcaaaac ag 52

<210> SEQ ID NO 125
<211> LENGTH: 52
<212> TYPE: DNA
<213> ORGANISM: Artificial Sequence
<220> FEATURE:
<223> OTHER INFORMATION: Description of Artificial Sequence: Synthetic primer

<400> SEQUENCE: 125
tgagaccagt ctcggaagct caaaggtctc gttttagagc tatgctgttt tg 52

<210> SEQ ID NO 126

-continued

<211> LENGTH: 35
<212> TYPE: DNA
<213> ORGANISM: Artificial Sequence
<220> FEATURE:
<223> OTHER INFORMATION: Description of Artificial Sequence: Synthetic primer

<400> SEQUENCE: 126

aaactacttt acgcagcgcg gagttcgggt ttttg 35

<210> SEQ ID NO 127
<211> LENGTH: 35
<212> TYPE: DNA
<213> ORGANISM: Artificial Sequence
<220> FEATURE:
<223> OTHER INFORMATION: Description of Artificial Sequence: Synthetic primer

<400> SEQUENCE: 127

aaaacaaaa accgaactcc gcgctgcgta aagta 35

<210> SEQ ID NO 128
<211> LENGTH: 45
<212> TYPE: DNA
<213> ORGANISM: Artificial Sequence
<220> FEATURE:
<223> OTHER INFORMATION: Description of Artificial Sequence: Synthetic primer

<400> SEQUENCE: 128

atgccggtac tgccgggcct cttgcgggat tacgaaatca tcttg 45

<210> SEQ ID NO 129
<211> LENGTH: 45
<212> TYPE: DNA
<213> ORGANISM: Artificial Sequence
<220> FEATURE:
<223> OTHER INFORMATION: Description of Artificial Sequence: Synthetic primer

<400> SEQUENCE: 129

gtgactggcg atgctgtcgg aatggacgat cacactactc ttctt 45

<210> SEQ ID NO 130
<211> LENGTH: 50
<212> TYPE: DNA
<213> ORGANISM: Artificial Sequence
<220> FEATURE:
<223> OTHER INFORMATION: Description of Artificial Sequence: Synthetic primer

<400> SEQUENCE: 130

ttaagaaata atcttcatct aaaatatact tcagtcacct cctagctgac 50

<210> SEQ ID NO 131
<211> LENGTH: 48
<212> TYPE: DNA
<213> ORGANISM: Artificial Sequence
<220> FEATURE:
<223> OTHER INFORMATION: Description of Artificial Sequence: Synthetic primer

<400> SEQUENCE: 131

attgattga gtcagctagg aggtgactga agtatatattt agatgaag 48

-continued

<210> SEQ ID NO 132
<211> LENGTH: 85
<212> TYPE: DNA
<213> ORGANISM: Artificial Sequence
<220> FEATURE:
<223> OTHER INFORMATION: Description of Artificial Sequence: Synthetic primer

<400> SEQUENCE: 132

gagacctttg agcttccgag actggtctca gttttgggac cattcaaac agcatagctc 60
taaacctcg tagactatct ttgtc 85

<210> SEQ ID NO 133
<211> LENGTH: 84
<212> TYPE: DNA
<213> ORGANISM: Artificial Sequence
<220> FEATURE:
<223> OTHER INFORMATION: Description of Artificial Sequence: Synthetic primer

<400> SEQUENCE: 133

gagaccagtc tcggaagctc aaaggtctcg ttttagagct atgctgtttt gaatggtccc 60
aaaacttcag cacactgaga ctgtc 84

<210> SEQ ID NO 134
<211> LENGTH: 21
<212> TYPE: DNA
<213> ORGANISM: Artificial Sequence
<220> FEATURE:
<223> OTHER INFORMATION: Description of Artificial Sequence: Synthetic primer

<400> SEQUENCE: 134

agtcaccca gcaacaaatg g 21

<210> SEQ ID NO 135
<211> LENGTH: 31
<212> TYPE: DNA
<213> ORGANISM: Artificial Sequence
<220> FEATURE:
<223> OTHER INFORMATION: Description of Artificial Sequence: Synthetic primer

<400> SEQUENCE: 135

cgtggtaaat cggataacgt tccaagtga g 31

<210> SEQ ID NO 136
<211> LENGTH: 22
<212> TYPE: DNA
<213> ORGANISM: Artificial Sequence
<220> FEATURE:
<223> OTHER INFORMATION: Description of Artificial Sequence: Synthetic primer

<400> SEQUENCE: 136

tgctcttctt cacaacaag gg 22

<210> SEQ ID NO 137
<211> LENGTH: 21
<212> TYPE: DNA
<213> ORGANISM: Artificial Sequence
<220> FEATURE:
<223> OTHER INFORMATION: Description of Artificial Sequence: Synthetic

-continued

primer

<400> SEQUENCE: 137

aagccaaagt ttggcaccac c 21

<210> SEQ ID NO 138
<211> LENGTH: 22
<212> TYPE: DNA
<213> ORGANISM: Artificial Sequence
<220> FEATURE:
<223> OTHER INFORMATION: Description of Artificial Sequence: Synthetic primer

<400> SEQUENCE: 138

gtagcttatt cagtcctagt gg 22

<210> SEQ ID NO 139
<211> LENGTH: 45
<212> TYPE: DNA
<213> ORGANISM: Artificial Sequence
<220> FEATURE:
<223> OTHER INFORMATION: Description of Artificial Sequence: Synthetic primer

<400> SEQUENCE: 139

cgtttgttga actaatgggt gcaaattacg aatcttctcc tgacg 45

<210> SEQ ID NO 140
<211> LENGTH: 45
<212> TYPE: DNA
<213> ORGANISM: Artificial Sequence
<220> FEATURE:
<223> OTHER INFORMATION: Description of Artificial Sequence: Synthetic primer

<400> SEQUENCE: 140

cgtcaggaga agattcgtaa tttgcacca ttagttcaac aaacg 45

<210> SEQ ID NO 141
<211> LENGTH: 48
<212> TYPE: DNA
<213> ORGANISM: Artificial Sequence
<220> FEATURE:
<223> OTHER INFORMATION: Description of Artificial Sequence: Synthetic primer

<400> SEQUENCE: 141

gatattatgg agcctatddd tgtgggtddd taggcataaa actatatg 48

<210> SEQ ID NO 142
<211> LENGTH: 48
<212> TYPE: DNA
<213> ORGANISM: Artificial Sequence
<220> FEATURE:
<223> OTHER INFORMATION: Description of Artificial Sequence: Synthetic primer

<400> SEQUENCE: 142

catatagddd tatgcctaaa aaccacaaa aataggctcc ataatatc 48

<210> SEQ ID NO 143
<211> LENGTH: 27
<212> TYPE: DNA
<213> ORGANISM: Artificial Sequence

-continued

<220> FEATURE:
<223> OTHER INFORMATION: Description of Artificial Sequence: Synthetic primer

<400> SEQUENCE: 143

attatttctt aataactaaa aatatgg 27

<210> SEQ ID NO 144
<211> LENGTH: 24
<212> TYPE: DNA
<213> ORGANISM: Artificial Sequence
<220> FEATURE:
<223> OTHER INFORMATION: Description of Artificial Sequence: Synthetic primer

<400> SEQUENCE: 144

cgtgtacaat tgctagcgtg cggc 24

<210> SEQ ID NO 145
<211> LENGTH: 24
<212> TYPE: DNA
<213> ORGANISM: Artificial Sequence
<220> FEATURE:
<223> OTHER INFORMATION: Description of Artificial Sequence: Synthetic primer

<400> SEQUENCE: 145

gcaccggtga tcactagtcc tagg 24

<210> SEQ ID NO 146
<211> LENGTH: 47
<212> TYPE: DNA
<213> ORGANISM: Artificial Sequence
<220> FEATURE:
<223> OTHER INFORMATION: Description of Artificial Sequence: Synthetic primer

<400> SEQUENCE: 146

cctaggacta gtgatcaccg gtgcaaatat gagccaaata aatatat 47

<210> SEQ ID NO 147
<211> LENGTH: 44
<212> TYPE: DNA
<213> ORGANISM: Artificial Sequence
<220> FEATURE:
<223> OTHER INFORMATION: Description of Artificial Sequence: Synthetic primer

<400> SEQUENCE: 147

gccgtacgct agcaattgta cacgtttggt gaactaatgg gtgc 44

<210> SEQ ID NO 148
<211> LENGTH: 25
<212> TYPE: DNA
<213> ORGANISM: Artificial Sequence
<220> FEATURE:
<223> OTHER INFORMATION: Description of Artificial Sequence: Synthetic primer

<400> SEQUENCE: 148

ttcaaatttt cccatttgat tetcc 25

<210> SEQ ID NO 149
<211> LENGTH: 47

-continued

<212> TYPE: DNA
<213> ORGANISM: Artificial Sequence
<220> FEATURE:
<223> OTHER INFORMATION: Description of Artificial Sequence: Synthetic primer

<400> SEQUENCE: 149

ccatattttt agttattaag aaataatacc agccatcagt cacctcc 47

<210> SEQ ID NO 150
<211> LENGTH: 23
<212> TYPE: DNA
<213> ORGANISM: Artificial Sequence
<220> FEATURE:
<223> OTHER INFORMATION: Description of Artificial Sequence: Synthetic primer

<400> SEQUENCE: 150

agacgattca atagacaata agg 23

<210> SEQ ID NO 151
<211> LENGTH: 45
<212> TYPE: DNA
<213> ORGANISM: Artificial Sequence
<220> FEATURE:
<223> OTHER INFORMATION: Description of Artificial Sequence: Synthetic primer

<400> SEQUENCE: 151

gttttgggac cattcaaaac agcatagctc taaaacctcg tagac 45

<210> SEQ ID NO 152
<211> LENGTH: 50
<212> TYPE: DNA
<213> ORGANISM: Artificial Sequence
<220> FEATURE:
<223> OTHER INFORMATION: Description of Artificial Sequence: Synthetic primer

<400> SEQUENCE: 152

gctatgctgt tttgaatggt cccaaaacca ttattttaac acacgaggtg 50

<210> SEQ ID NO 153
<211> LENGTH: 50
<212> TYPE: DNA
<213> ORGANISM: Artificial Sequence
<220> FEATURE:
<223> OTHER INFORMATION: Description of Artificial Sequence: Synthetic primer

<400> SEQUENCE: 153

gctatgctgt tttgaatggt cccaaaacgc acccattagt tcaacaaacy 50

<210> SEQ ID NO 154
<211> LENGTH: 23
<212> TYPE: DNA
<213> ORGANISM: Artificial Sequence
<220> FEATURE:
<223> OTHER INFORMATION: Description of Artificial Sequence: Synthetic primer

<400> SEQUENCE: 154

aattcttttc ttcacatcgc gtc 23

-continued

<210> SEQ ID NO 155
<211> LENGTH: 24
<212> TYPE: DNA
<213> ORGANISM: Artificial Sequence
<220> FEATURE:
<223> OTHER INFORMATION: Description of Artificial Sequence: Synthetic primer

<400> SEQUENCE: 155

aagaaagaat gaagattggt catg 24

<210> SEQ ID NO 156
<211> LENGTH: 25
<212> TYPE: DNA
<213> ORGANISM: Artificial Sequence
<220> FEATURE:
<223> OTHER INFORMATION: Description of Artificial Sequence: Synthetic primer

<400> SEQUENCE: 156

ggtactaatc aaaatagtga ggagg 25

<210> SEQ ID NO 157
<211> LENGTH: 23
<212> TYPE: DNA
<213> ORGANISM: Artificial Sequence
<220> FEATURE:
<223> OTHER INFORMATION: Description of Artificial Sequence: Synthetic primer

<400> SEQUENCE: 157

gtttttcaaa atctgcgggt gcg 23

<210> SEQ ID NO 158
<211> LENGTH: 26
<212> TYPE: DNA
<213> ORGANISM: Artificial Sequence
<220> FEATURE:
<223> OTHER INFORMATION: Description of Artificial Sequence: Synthetic primer

<400> SEQUENCE: 158

aaaaattgaa aaaatggtgg aaacac 26

<210> SEQ ID NO 159
<211> LENGTH: 53
<212> TYPE: DNA
<213> ORGANISM: Artificial Sequence
<220> FEATURE:
<223> OTHER INFORMATION: Description of Artificial Sequence: Synthetic primer

<400> SEQUENCE: 159

atttcgtaaa cggatcgggt ttcttttaaa gttttgggac cattcaaaac agc 53

<210> SEQ ID NO 160
<211> LENGTH: 53
<212> TYPE: DNA
<213> ORGANISM: Artificial Sequence
<220> FEATURE:
<223> OTHER INFORMATION: Description of Artificial Sequence: Synthetic primer

<400> SEQUENCE: 160

tttaaaagaa accgataccg ttacgaaat gttttagagc tatgctgttt tga 53

-continued

<210> SEQ ID NO 161
<211> LENGTH: 53
<212> TYPE: DNA
<213> ORGANISM: Artificial Sequence
<220> FEATURE:
<223> OTHER INFORMATION: Description of Artificial Sequence: Synthetic
primer

<400> SEQUENCE: 161

aaacggatc ggtttctttt aaattcaatt gttttgggac cattcaaac agc 53

<210> SEQ ID NO 162
<211> LENGTH: 53
<212> TYPE: DNA
<213> ORGANISM: Artificial Sequence
<220> FEATURE:
<223> OTHER INFORMATION: Description of Artificial Sequence: Synthetic
primer

<400> SEQUENCE: 162

aattgaattt aaaagaaacc gataccggtt gtttagagc tatgctggtt tga 53

<210> SEQ ID NO 163
<211> LENGTH: 39
<212> TYPE: DNA
<213> ORGANISM: Artificial Sequence
<220> FEATURE:
<223> OTHER INFORMATION: Description of Artificial Sequence: Synthetic
primer

<400> SEQUENCE: 163

gttccttaaa ccaaaacggt atcggtttct ttaaattc 39

<210> SEQ ID NO 164
<211> LENGTH: 47
<212> TYPE: DNA
<213> ORGANISM: Artificial Sequence
<220> FEATURE:
<223> OTHER INFORMATION: Description of Artificial Sequence: Synthetic
primer

<400> SEQUENCE: 164

gaaaccgata ccgttttggt ttaaggaaca ggtaaagggc attaac 47

<210> SEQ ID NO 165
<211> LENGTH: 22
<212> TYPE: DNA
<213> ORGANISM: Artificial Sequence
<220> FEATURE:
<223> OTHER INFORMATION: Description of Artificial Sequence: Synthetic
primer

<400> SEQUENCE: 165

cgatttcagc cattgectcg tc 22

<210> SEQ ID NO 166
<211> LENGTH: 56
<212> TYPE: DNA
<213> ORGANISM: Artificial Sequence
<220> FEATURE:
<223> OTHER INFORMATION: Description of Artificial Sequence: Synthetic
primer
<220> FEATURE:
<221> NAME/KEY: modified_base

-continued

<222> LOCATION: (29)..(33)
<223> OTHER INFORMATION: a, c, t, g, unknown or other

<400> SEQUENCE: 166

gcctttgacg aggcaatggc tgaatcggn nnaaaaaagc gcaagaagaa atcaac 56

<210> SEQ ID NO 167
<211> LENGTH: 53
<212> TYPE: DNA
<213> ORGANISM: Artificial Sequence
<220> FEATURE:
<223> OTHER INFORMATION: Description of Artificial Sequence: Synthetic primer

<400> SEQUENCE: 167

tccgtacaac ccacaacct gctagtgagc gttttgggac cattcaaac agc 53

<210> SEQ ID NO 168
<211> LENGTH: 53
<212> TYPE: DNA
<213> ORGANISM: Artificial Sequence
<220> FEATURE:
<223> OTHER INFORMATION: Description of Artificial Sequence: Synthetic primer

<400> SEQUENCE: 168

gctcactagc aggggtgtgg gttgtacgga gtttagagc tatgctgttt tga 53

<210> SEQ ID NO 169
<211> LENGTH: 23
<212> TYPE: DNA
<213> ORGANISM: Artificial Sequence
<220> FEATURE:
<223> OTHER INFORMATION: Description of Artificial Sequence: Synthetic primer

<400> SEQUENCE: 169

ttggtgccac tcttcttct ttc 23

<210> SEQ ID NO 170
<211> LENGTH: 41
<212> TYPE: DNA
<213> ORGANISM: Artificial Sequence
<220> FEATURE:
<223> OTHER INFORMATION: Description of Artificial Sequence: Synthetic primer

<400> SEQUENCE: 170

cagggttg tg gttgttgcg atggagtaa ctcccatctc c 41

<210> SEQ ID NO 171
<211> LENGTH: 41
<212> TYPE: DNA
<213> ORGANISM: Artificial Sequence
<220> FEATURE:
<223> OTHER INFORMATION: Description of Artificial Sequence: Synthetic primer

<400> SEQUENCE: 171

gggagttaac tccatcgcaa caaccacaa cctgtagt g 41

<210> SEQ ID NO 172
<211> LENGTH: 22
<212> TYPE: DNA

-continued

<213> ORGANISM: Artificial Sequence
<220> FEATURE:
<223> OTHER INFORMATION: Description of Artificial Sequence: Synthetic primer

<400> SEQUENCE: 172
gtggtatcta tcgtgatgtg ac 22

<210> SEQ ID NO 173
<211> LENGTH: 23
<212> TYPE: DNA
<213> ORGANISM: Artificial Sequence
<220> FEATURE:
<223> OTHER INFORMATION: Description of Artificial Sequence: Synthetic primer

<400> SEQUENCE: 173
ttaccgaaac ggaatttattc tgc 23

<210> SEQ ID NO 174
<211> LENGTH: 22
<212> TYPE: DNA
<213> ORGANISM: Artificial Sequence
<220> FEATURE:
<223> OTHER INFORMATION: Description of Artificial Sequence: Synthetic primer

<400> SEQUENCE: 174
aaagctagag ttccgcaatt gg 22

<210> SEQ ID NO 175
<211> LENGTH: 37
<212> TYPE: DNA
<213> ORGANISM: Artificial Sequence
<220> FEATURE:
<223> OTHER INFORMATION: Description of Artificial Sequence: Synthetic primer

<400> SEQUENCE: 175
gtgggttgta cggattgagt taactcccat etccttc 37

<210> SEQ ID NO 176
<211> LENGTH: 38
<212> TYPE: DNA
<213> ORGANISM: Artificial Sequence
<220> FEATURE:
<223> OTHER INFORMATION: Description of Artificial Sequence: Synthetic primer

<400> SEQUENCE: 176
gatgggagtt aactcaatcc gtacaacca caaccctg 38

<210> SEQ ID NO 177
<211> LENGTH: 40
<212> TYPE: DNA
<213> ORGANISM: Artificial Sequence
<220> FEATURE:
<223> OTHER INFORMATION: Description of Artificial Sequence: Synthetic primer

<400> SEQUENCE: 177
gcttcaccta ttgcagcacc aattgaccac atgaagatag 40

<210> SEQ ID NO 178

-continued

<211> LENGTH: 41
<212> TYPE: DNA
<213> ORGANISM: Artificial Sequence
<220> FEATURE:
<223> OTHER INFORMATION: Description of Artificial Sequence: Synthetic primer

<400> SEQUENCE: 178

gtggtcaatt ggtgctgcaa taggtgaagc taatggtgat g 41

<210> SEQ ID NO 179
<211> LENGTH: 39
<212> TYPE: DNA
<213> ORGANISM: Artificial Sequence
<220> FEATURE:
<223> OTHER INFORMATION: Description of Artificial Sequence: Synthetic primer

<400> SEQUENCE: 179

ctgatttgta ttaatttga gacattatgc ttcaccttc 39

<210> SEQ ID NO 180
<211> LENGTH: 40
<212> TYPE: DNA
<213> ORGANISM: Artificial Sequence
<220> FEATURE:
<223> OTHER INFORMATION: Description of Artificial Sequence: Synthetic primer

<400> SEQUENCE: 180

gcataatgtc tcaaaattaa tacaaatcag tgaaatcatg 40

<210> SEQ ID NO 181
<211> LENGTH: 52
<212> TYPE: DNA
<213> ORGANISM: Artificial Sequence
<220> FEATURE:
<223> OTHER INFORMATION: Description of Artificial Sequence: Synthetic primer

<400> SEQUENCE: 181

gttttgggac cattcaaaac agcatagctc taaaacgtga cagtaatatc ag 52

<210> SEQ ID NO 182
<211> LENGTH: 53
<212> TYPE: DNA
<213> ORGANISM: Artificial Sequence
<220> FEATURE:
<223> OTHER INFORMATION: Description of Artificial Sequence: Synthetic primer

<400> SEQUENCE: 182

gttttagagc tatgctgttt tgaatggtcc caaaaagctc actagcaggg ttg 53

<210> SEQ ID NO 183
<211> LENGTH: 59
<212> TYPE: DNA
<213> ORGANISM: Artificial Sequence
<220> FEATURE:
<223> OTHER INFORMATION: Description of Artificial Sequence: Synthetic primer

<400> SEQUENCE: 183

atactttacg cagcgcgagg ttcggttttg taggagtggt agtatatata cgagtacat 59

-continued

<210> SEQ ID NO 184
<211> LENGTH: 33
<212> TYPE: DNA
<213> ORGANISM: Artificial Sequence
<220> FEATURE:
<223> OTHER INFORMATION: Description of Artificial Sequence: Synthetic
oligonucleotide

<400> SEQUENCE: 184

gctcactagc agggttgtgg gttgtacgga tgg 33

<210> SEQ ID NO 185
<211> LENGTH: 33
<212> TYPE: DNA
<213> ORGANISM: Artificial Sequence
<220> FEATURE:
<223> OTHER INFORMATION: Description of Artificial Sequence: Synthetic
oligonucleotide

<400> SEQUENCE: 185

tcctagcagg atttctgata ttactgtcac tgg 33

<210> SEQ ID NO 186
<211> LENGTH: 33
<212> TYPE: DNA
<213> ORGANISM: Artificial Sequence
<220> FEATURE:
<223> OTHER INFORMATION: Description of Artificial Sequence: Synthetic
oligonucleotide

<400> SEQUENCE: 186

tttaaaagaa accgataccg tttacgaaat tgg 33

<210> SEQ ID NO 187
<211> LENGTH: 84
<212> TYPE: DNA
<213> ORGANISM: Artificial Sequence
<220> FEATURE:
<223> OTHER INFORMATION: Description of Artificial Sequence: Synthetic
oligonucleotide

<400> SEQUENCE: 187

ggaaccattc ataacagcat agcaagttat aataaggeta gtccggtatc aacttgaaaa 60

agtggcaccg agtcggtgct tttt 84

<210> SEQ ID NO 188
<211> LENGTH: 36
<212> TYPE: DNA
<213> ORGANISM: Artificial Sequence
<220> FEATURE:
<223> OTHER INFORMATION: Description of Artificial Sequence: Synthetic
oligonucleotide

<400> SEQUENCE: 188

gttatagagc tatgctgtta tgaatggtcc caaaac 36

<210> SEQ ID NO 189
<211> LENGTH: 84
<212> TYPE: DNA
<213> ORGANISM: Artificial Sequence
<220> FEATURE:
<223> OTHER INFORMATION: Description of Artificial Sequence: Synthetic
oligonucleotide

-continued

<400> SEQUENCE: 189

ggaaccattc aatacagcat agcaagtaa tataaggcta gtccgttadc aacttgaaaa 60

agtggcaccg agtcggtgct tttt 84

<210> SEQ ID NO 190

<211> LENGTH: 36

<212> TYPE: DNA

<213> ORGANISM: Artificial Sequence

<220> FEATURE:

<223> OTHER INFORMATION: Description of Artificial Sequence: Synthetic oligonucleotide

<400> SEQUENCE: 190

gtattagagc tatgctgtat tgaatggtcc caaaac 36

<210> SEQ ID NO 191

<211> LENGTH: 103

<212> TYPE: DNA

<213> ORGANISM: Artificial Sequence

<220> FEATURE:

<223> OTHER INFORMATION: Description of Artificial Sequence: Synthetic polynucleotide

<220> FEATURE:

<221> NAME/KEY: modified_base

<222> LOCATION: (1)..(20)

<223> OTHER INFORMATION: a, c, t, g, unknown or other

<400> SEQUENCE: 191

nnnnnnnnnn nnnnnnnnnn gttttagagc tagaaatagc aagttaaat aaggctagtc 60

cgttatcaac ttgaaaaagt ggcaccgagt cgggtctttt ttt 103

<210> SEQ ID NO 192

<211> LENGTH: 103

<212> TYPE: DNA

<213> ORGANISM: Artificial Sequence

<220> FEATURE:

<223> OTHER INFORMATION: Description of Artificial Sequence: Synthetic polynucleotide

<220> FEATURE:

<221> NAME/KEY: modified_base

<222> LOCATION: (1)..(20)

<223> OTHER INFORMATION: a, c, t, g, unknown or other

<400> SEQUENCE: 192

nnnnnnnnnn nnnnnnnnnn gtattagagc tagaaatagc aagttaatat aaggctagtc 60

cgttatcaac ttgaaaaagt ggcaccgagt cgggtctttt ttt 103

<210> SEQ ID NO 193

<211> LENGTH: 123

<212> TYPE: DNA

<213> ORGANISM: Artificial Sequence

<220> FEATURE:

<223> OTHER INFORMATION: Description of Artificial Sequence: Synthetic polynucleotide

<220> FEATURE:

<221> NAME/KEY: modified_base

<222> LOCATION: (1)..(20)

<223> OTHER INFORMATION: a, c, t, g, unknown or other

<400> SEQUENCE: 193

nnnnnnnnnn nnnnnnnnnn gttttagagc tatgctgttt tggaacaaa acagcatagc 60

aagttaaat aaggctagtc cgttatcaac ttgaaaaagt ggcaccgagt cgggtctttt 120

-continued

ttt	123
<p><210> SEQ ID NO 194 <211> LENGTH: 123 <212> TYPE: DNA <213> ORGANISM: Artificial Sequence <220> FEATURE: <223> OTHER INFORMATION: Description of Artificial Sequence: Synthetic polynucleotide <220> FEATURE: <221> NAME/KEY: modified_base <222> LOCATION: (1)..(20) <223> OTHER INFORMATION: a, c, t, g, unknown or other</p>	
<400> SEQUENCE: 194	
nnnnnnnnnn nnnnnnnnnn gtattagagc tatgctgtat tggaacaat acagcatagc	60
aagttaatat aaggctagtc cgttatcaac ttgaaaaagt ggcaccgagt cggtgctttt	120
ttt	123
<p><210> SEQ ID NO 195 <211> LENGTH: 20 <212> TYPE: DNA <213> ORGANISM: Homo sapiens</p>	
<400> SEQUENCE: 195	
gtcacctcca atgactaggg	20
<p><210> SEQ ID NO 196 <211> LENGTH: 23 <212> TYPE: DNA <213> ORGANISM: Homo sapiens</p>	
<400> SEQUENCE: 196	
gacatcgatg tectccccat tgg	23
<p><210> SEQ ID NO 197 <211> LENGTH: 23 <212> TYPE: DNA <213> ORGANISM: Homo sapiens</p>	
<400> SEQUENCE: 197	
gagtccgagc agaagaagaa ggg	23
<p><210> SEQ ID NO 198 <211> LENGTH: 23 <212> TYPE: DNA <213> ORGANISM: Homo sapiens</p>	
<400> SEQUENCE: 198	
gcgccaccgg ttgatgtgat ggg	23
<p><210> SEQ ID NO 199 <211> LENGTH: 23 <212> TYPE: DNA <213> ORGANISM: Homo sapiens</p>	
<400> SEQUENCE: 199	
ggggcacaga tgagaaactc agg	23
<p><210> SEQ ID NO 200 <211> LENGTH: 23</p>	

-continued

<212> TYPE: DNA
<213> ORGANISM: Homo sapiens

<400> SEQUENCE: 200
gtacaaacgg cagaagctgg agg 23

<210> SEQ ID NO 201
<211> LENGTH: 23
<212> TYPE: DNA
<213> ORGANISM: Homo sapiens

<400> SEQUENCE: 201
ggcagaagct ggaggaggaa ggg 23

<210> SEQ ID NO 202
<211> LENGTH: 23
<212> TYPE: DNA
<213> ORGANISM: Homo sapiens

<400> SEQUENCE: 202
ggagcccttc ttcttctgct cgg 23

<210> SEQ ID NO 203
<211> LENGTH: 23
<212> TYPE: DNA
<213> ORGANISM: Homo sapiens

<400> SEQUENCE: 203
gggcaaccac aaaccacga ggg 23

<210> SEQ ID NO 204
<211> LENGTH: 23
<212> TYPE: DNA
<213> ORGANISM: Homo sapiens

<400> SEQUENCE: 204
gtcccatca catcaaccgg tgg 23

<210> SEQ ID NO 205
<211> LENGTH: 23
<212> TYPE: DNA
<213> ORGANISM: Homo sapiens

<400> SEQUENCE: 205
gtggcgcatt gccacgaagc agg 23

<210> SEQ ID NO 206
<211> LENGTH: 23
<212> TYPE: DNA
<213> ORGANISM: Homo sapiens

<400> SEQUENCE: 206
ggcagagtgc tgcttgctgc tgg 23

<210> SEQ ID NO 207
<211> LENGTH: 23
<212> TYPE: DNA
<213> ORGANISM: Homo sapiens

<400> SEQUENCE: 207
gcccctgcgt gggcccaagc tgg 23

-continued

<210> SEQ ID NO 208
<211> LENGTH: 23
<212> TYPE: DNA
<213> ORGANISM: Homo sapiens

<400> SEQUENCE: 208

gagtggccag agtccagctt ggg 23

<210> SEQ ID NO 209
<211> LENGTH: 23
<212> TYPE: DNA
<213> ORGANISM: Homo sapiens

<400> SEQUENCE: 209

ggcctcccca aagcctggcc agg 23

<210> SEQ ID NO 210
<211> LENGTH: 23
<212> TYPE: DNA
<213> ORGANISM: Homo sapiens

<400> SEQUENCE: 210

ggggccgaga ttgggtgttc agg 23

<210> SEQ ID NO 211
<211> LENGTH: 23
<212> TYPE: DNA
<213> ORGANISM: Homo sapiens

<400> SEQUENCE: 211

gtggcgagag gggccgagat tgg 23

<210> SEQ ID NO 212
<211> LENGTH: 23
<212> TYPE: DNA
<213> ORGANISM: Homo sapiens

<400> SEQUENCE: 212

gagtgccgcc gaggcggggc ggg 23

<210> SEQ ID NO 213
<211> LENGTH: 23
<212> TYPE: DNA
<213> ORGANISM: Homo sapiens

<400> SEQUENCE: 213

ggagtgccgc cgaggcgggg cgg 23

<210> SEQ ID NO 214
<211> LENGTH: 23
<212> TYPE: DNA
<213> ORGANISM: Homo sapiens

<400> SEQUENCE: 214

ggagaggagt gccgccgagg cgg 23

<210> SEQ ID NO 215
<211> LENGTH: 20
<212> TYPE: DNA
<213> ORGANISM: Artificial Sequence

-continued

<220> FEATURE:
<223> OTHER INFORMATION: Description of Artificial Sequence: Synthetic primer

<400> SEQUENCE: 215

ccatcccctt ctgtgaatgt 20

<210> SEQ ID NO 216
<211> LENGTH: 20
<212> TYPE: DNA
<213> ORGANISM: Artificial Sequence
<220> FEATURE:
<223> OTHER INFORMATION: Description of Artificial Sequence: Synthetic primer

<400> SEQUENCE: 216

ggagattgga gacacggaga 20

<210> SEQ ID NO 217
<211> LENGTH: 20
<212> TYPE: DNA
<213> ORGANISM: Artificial Sequence
<220> FEATURE:
<223> OTHER INFORMATION: Description of Artificial Sequence: Synthetic primer

<400> SEQUENCE: 217

aagcaccgac tcggtgccac 20

<210> SEQ ID NO 218
<211> LENGTH: 20
<212> TYPE: DNA
<213> ORGANISM: Artificial Sequence
<220> FEATURE:
<223> OTHER INFORMATION: Description of Artificial Sequence: Synthetic primer

<400> SEQUENCE: 218

tcacctcaa tgactagggg 20

<210> SEQ ID NO 219
<211> LENGTH: 22
<212> TYPE: DNA
<213> ORGANISM: Artificial Sequence
<220> FEATURE:
<223> OTHER INFORMATION: Description of Artificial Sequence: Synthetic primer

<400> SEQUENCE: 219

caagttgata acggactagc ct 22

<210> SEQ ID NO 220
<211> LENGTH: 23
<212> TYPE: DNA
<213> ORGANISM: Artificial Sequence
<220> FEATURE:
<223> OTHER INFORMATION: Description of Artificial Sequence: Synthetic primer

<400> SEQUENCE: 220

agtccgagca gaagaagaag ttt 23

<210> SEQ ID NO 221
<211> LENGTH: 25

-continued

<212> TYPE: DNA
<213> ORGANISM: Artificial Sequence
<220> FEATURE:
<223> OTHER INFORMATION: Description of Artificial Sequence: Synthetic primer

<400> SEQUENCE: 221

tttcaagttg ataacggact agcct 25

<210> SEQ ID NO 222
<211> LENGTH: 20
<212> TYPE: DNA
<213> ORGANISM: Artificial Sequence
<220> FEATURE:
<223> OTHER INFORMATION: Description of Artificial Sequence: Synthetic primer

<400> SEQUENCE: 222

aaacagcaga ttcgcctgga 20

<210> SEQ ID NO 223
<211> LENGTH: 20
<212> TYPE: DNA
<213> ORGANISM: Artificial Sequence
<220> FEATURE:
<223> OTHER INFORMATION: Description of Artificial Sequence: Synthetic primer

<400> SEQUENCE: 223

tcacccgctc gatgaagctc 20

<210> SEQ ID NO 224
<211> LENGTH: 20
<212> TYPE: DNA
<213> ORGANISM: Artificial Sequence
<220> FEATURE:
<223> OTHER INFORMATION: Description of Artificial Sequence: Synthetic primer

<400> SEQUENCE: 224

tccaaaatca agtggggcga 20

<210> SEQ ID NO 225
<211> LENGTH: 20
<212> TYPE: DNA
<213> ORGANISM: Artificial Sequence
<220> FEATURE:
<223> OTHER INFORMATION: Description of Artificial Sequence: Synthetic primer

<400> SEQUENCE: 225

tgatgaccct tttggctccc 20

<210> SEQ ID NO 226
<211> LENGTH: 45
<212> TYPE: DNA
<213> ORGANISM: Artificial Sequence
<220> FEATURE:
<223> OTHER INFORMATION: Description of Artificial Sequence: Synthetic primer

<400> SEQUENCE: 226

gaggaattct ttttttgty gaatatgty gaggtttttt ggaag 45

-continued

<210> SEQ ID NO 227
<211> LENGTH: 42
<212> TYPE: DNA
<213> ORGANISM: Artificial Sequence
<220> FEATURE:
<223> OTHER INFORMATION: Description of Artificial Sequence: Synthetic primer

<400> SEQUENCE: 227

gagaagctta aataaaaaac racaatactc aacccaaca cc 42

<210> SEQ ID NO 228
<211> LENGTH: 17
<212> TYPE: DNA
<213> ORGANISM: Artificial Sequence
<220> FEATURE:
<223> OTHER INFORMATION: Description of Artificial Sequence: Synthetic primer

<400> SEQUENCE: 228

caggaaacag ctatgac 17

<210> SEQ ID NO 229
<211> LENGTH: 39
<212> TYPE: DNA
<213> ORGANISM: Artificial Sequence
<220> FEATURE:
<223> OTHER INFORMATION: Description of Artificial Sequence: Synthetic primer

<400> SEQUENCE: 229

gcctctagag gtacctgagg gcctatttcc catgattcc 39

<210> SEQ ID NO 230
<211> LENGTH: 133
<212> TYPE: DNA
<213> ORGANISM: Artificial Sequence
<220> FEATURE:
<223> OTHER INFORMATION: Description of Artificial Sequence: Synthetic primer
<220> FEATURE:
<221> NAME/KEY: modified_base
<222> LOCATION: (92)..(111)
<223> OTHER INFORMATION: a, c, t, g, unknown or other

<400> SEQUENCE: 230

acctctagaa aaaagcacc gactcgggtgc cactttttca agttgataac ggactagcct 60
tattttaact tgetatttct agctctaaaa cnnnnnnnnn nnnnnnnnn nggtgtttcg 120
tcctttccac aag 133

<210> SEQ ID NO 231
<211> LENGTH: 133
<212> TYPE: DNA
<213> ORGANISM: Artificial Sequence
<220> FEATURE:
<223> OTHER INFORMATION: Description of Artificial Sequence: Synthetic primer
<220> FEATURE:
<221> NAME/KEY: modified_base
<222> LOCATION: (92)..(111)
<223> OTHER INFORMATION: a, c, t, g, unknown or other

<400> SEQUENCE: 231

acctctagaa aaaagcacc gactcgggtgc cactttttca agttgataac ggactagcct 60

-continued

 tatattaact tgctatttct agctctaata cnnnnnnnnn nnnnnnnnnn nggtgtttcg 120

tcctttccac aag 133

<210> SEQ ID NO 232

<211> LENGTH: 153

<212> TYPE: DNA

<213> ORGANISM: Artificial Sequence

<220> FEATURE:

<223> OTHER INFORMATION: Description of Artificial Sequence: Synthetic primer

<220> FEATURE:

<221> NAME/KEY: modified_base

<222> LOCATION: (112)..(131)

<223> OTHER INFORMATION: a, c, t, g, unknown or other

<400> SEQUENCE: 232

acctctagaa aaaaagcacc gactcgggtgc cactttttca agttgataac ggactagcct 60

tattttaact tgctatgctg ttttgtttcc aaaacagcat agctctaaaa cnnnnnnnnn 120

nnnnnnnnnn nggtgtttcg tcctttccac aag 153

<210> SEQ ID NO 233

<211> LENGTH: 153

<212> TYPE: DNA

<213> ORGANISM: Artificial Sequence

<220> FEATURE:

<223> OTHER INFORMATION: Description of Artificial Sequence: Synthetic primer

<220> FEATURE:

<221> NAME/KEY: modified_base

<222> LOCATION: (112)..(131)

<223> OTHER INFORMATION: a, c, t, g, unknown or other

<400> SEQUENCE: 233

acctctagaa aaaaagcacc gactcgggtgc cactttttca agttgataac ggactagcct 60

tatattaact tgctatgctg tattgtttcc aatacagcat agctctaata cnnnnnnnnn 120

nnnnnnnnnn nggtgtttcg tcctttccac aag 153

<210> SEQ ID NO 234

<211> LENGTH: 22

<212> TYPE: DNA

<213> ORGANISM: Homo sapiens

<220> FEATURE:

<221> NAME/KEY: modified_base

<222> LOCATION: (20)..(20)

<223> OTHER INFORMATION: a, c, t, g, unknown or other

<400> SEQUENCE: 234

aggccccagt ggetgctctn aa 22

<210> SEQ ID NO 235

<211> LENGTH: 22

<212> TYPE: DNA

<213> ORGANISM: Homo sapiens

<220> FEATURE:

<221> NAME/KEY: modified_base

<222> LOCATION: (20)..(20)

<223> OTHER INFORMATION: a, c, t, g, unknown or other

<400> SEQUENCE: 235

acatcaaccg gtggcgcath at 22

<210> SEQ ID NO 236

-continued

<211> LENGTH: 22
<212> TYPE: DNA
<213> ORGANISM: Homo sapiens
<220> FEATURE:
<221> NAME/KEY: modified_base
<222> LOCATION: (20)..(20)
<223> OTHER INFORMATION: a, c, t, g, unknown or other

<400> SEQUENCE: 236

aaggtgtggt tccagaacn ac 22

<210> SEQ ID NO 237
<211> LENGTH: 22
<212> TYPE: DNA
<213> ORGANISM: Homo sapiens
<220> FEATURE:
<221> NAME/KEY: modified_base
<222> LOCATION: (20)..(20)
<223> OTHER INFORMATION: a, c, t, g, unknown or other

<400> SEQUENCE: 237

ccatcacatc aaccggtggn ag 22

<210> SEQ ID NO 238
<211> LENGTH: 22
<212> TYPE: DNA
<213> ORGANISM: Homo sapiens
<220> FEATURE:
<221> NAME/KEY: modified_base
<222> LOCATION: (20)..(20)
<223> OTHER INFORMATION: a, c, t, g, unknown or other

<400> SEQUENCE: 238

aaacggcaga agctggagggn ta 22

<210> SEQ ID NO 239
<211> LENGTH: 22
<212> TYPE: DNA
<213> ORGANISM: Homo sapiens
<220> FEATURE:
<221> NAME/KEY: modified_base
<222> LOCATION: (20)..(20)
<223> OTHER INFORMATION: a, c, t, g, unknown or other

<400> SEQUENCE: 239

ggcagaagct ggaggaggan tt 22

<210> SEQ ID NO 240
<211> LENGTH: 22
<212> TYPE: DNA
<213> ORGANISM: Homo sapiens
<220> FEATURE:
<221> NAME/KEY: modified_base
<222> LOCATION: (20)..(20)
<223> OTHER INFORMATION: a, c, t, g, unknown or other

<400> SEQUENCE: 240

gggtgtggttc cagaaccggn tc 22

<210> SEQ ID NO 241
<211> LENGTH: 22
<212> TYPE: DNA
<213> ORGANISM: Homo sapiens
<220> FEATURE:
<221> NAME/KEY: modified_base
<222> LOCATION: (20)..(20)

-continued

<223> OTHER INFORMATION: a, c, t, g, unknown or other

<400> SEQUENCE: 241

aaccggagga caaagtacan tg 22

<210> SEQ ID NO 242
<211> LENGTH: 22
<212> TYPE: DNA
<213> ORGANISM: Homo sapiens
<220> FEATURE:
<221> NAME/KEY: modified_base
<222> LOCATION: (20)..(20)
<223> OTHER INFORMATION: a, c, t, g, unknown or other

<400> SEQUENCE: 242

ttccagaacc ggaggacaan ca 22

<210> SEQ ID NO 243
<211> LENGTH: 22
<212> TYPE: DNA
<213> ORGANISM: Homo sapiens
<220> FEATURE:
<221> NAME/KEY: modified_base
<222> LOCATION: (20)..(20)
<223> OTHER INFORMATION: a, c, t, g, unknown or other

<400> SEQUENCE: 243

gtgtggttcc agaaccggan ct 22

<210> SEQ ID NO 244
<211> LENGTH: 22
<212> TYPE: DNA
<213> ORGANISM: Homo sapiens
<220> FEATURE:
<221> NAME/KEY: modified_base
<222> LOCATION: (20)..(20)
<223> OTHER INFORMATION: a, c, t, g, unknown or other

<400> SEQUENCE: 244

tccagaaccg gaggacaan cc 22

<210> SEQ ID NO 245
<211> LENGTH: 22
<212> TYPE: DNA
<213> ORGANISM: Homo sapiens
<220> FEATURE:
<221> NAME/KEY: modified_base
<222> LOCATION: (20)..(20)
<223> OTHER INFORMATION: a, c, t, g, unknown or other

<400> SEQUENCE: 245

cagaagctgg aggaggaagn cg 22

<210> SEQ ID NO 246
<211> LENGTH: 22
<212> TYPE: DNA
<213> ORGANISM: Homo sapiens
<220> FEATURE:
<221> NAME/KEY: modified_base
<222> LOCATION: (20)..(20)
<223> OTHER INFORMATION: a, c, t, g, unknown or other

<400> SEQUENCE: 246

catcaaccgg tggcgcattn ga 22

-continued

<210> SEQ ID NO 247
<211> LENGTH: 22
<212> TYPE: DNA
<213> ORGANISM: Homo sapiens
<220> FEATURE:
<221> NAME/KEY: modified_base
<222> LOCATION: (20)..(20)
<223> OTHER INFORMATION: a, c, t, g, unknown or other

<400> SEQUENCE: 247

gcagaagctg gaggaggaan gt 22

<210> SEQ ID NO 248
<211> LENGTH: 22
<212> TYPE: DNA
<213> ORGANISM: Homo sapiens
<220> FEATURE:
<221> NAME/KEY: modified_base
<222> LOCATION: (20)..(20)
<223> OTHER INFORMATION: a, c, t, g, unknown or other

<400> SEQUENCE: 248

cctccctccc tggcccaggn gc 22

<210> SEQ ID NO 249
<211> LENGTH: 22
<212> TYPE: DNA
<213> ORGANISM: Homo sapiens
<220> FEATURE:
<221> NAME/KEY: modified_base
<222> LOCATION: (20)..(20)
<223> OTHER INFORMATION: a, c, t, g, unknown or other

<400> SEQUENCE: 249

tcattctgtgc cctccctcna aa 22

<210> SEQ ID NO 250
<211> LENGTH: 22
<212> TYPE: DNA
<213> ORGANISM: Homo sapiens
<220> FEATURE:
<221> NAME/KEY: modified_base
<222> LOCATION: (20)..(20)
<223> OTHER INFORMATION: a, c, t, g, unknown or other

<400> SEQUENCE: 250

gggaggacat cgatgtcact at 22

<210> SEQ ID NO 251
<211> LENGTH: 22
<212> TYPE: DNA
<213> ORGANISM: Homo sapiens
<220> FEATURE:
<221> NAME/KEY: modified_base
<222> LOCATION: (20)..(20)
<223> OTHER INFORMATION: a, c, t, g, unknown or other

<400> SEQUENCE: 251

caaacggcag aagctggagn ac 22

<210> SEQ ID NO 252
<211> LENGTH: 22
<212> TYPE: DNA
<213> ORGANISM: Homo sapiens
<220> FEATURE:

-continued

<221> NAME/KEY: modified_base
<222> LOCATION: (20)..(20)
<223> OTHER INFORMATION: a, c, t, g, unknown or other

<400> SEQUENCE: 252

gggtgggcaa ccacaaacn ag 22

<210> SEQ ID NO 253
<211> LENGTH: 22
<212> TYPE: DNA
<213> ORGANISM: Homo sapiens
<220> FEATURE:
<221> NAME/KEY: modified_base
<222> LOCATION: (20)..(20)
<223> OTHER INFORMATION: a, c, t, g, unknown or other

<400> SEQUENCE: 253

ggtgggcaac cacaaacn ta 22

<210> SEQ ID NO 254
<211> LENGTH: 22
<212> TYPE: DNA
<213> ORGANISM: Homo sapiens
<220> FEATURE:
<221> NAME/KEY: modified_base
<222> LOCATION: (20)..(20)
<223> OTHER INFORMATION: a, c, t, g, unknown or other

<400> SEQUENCE: 254

ggctcccatc acatcaacn tt 22

<210> SEQ ID NO 255
<211> LENGTH: 22
<212> TYPE: DNA
<213> ORGANISM: Homo sapiens
<220> FEATURE:
<221> NAME/KEY: modified_base
<222> LOCATION: (20)..(20)
<223> OTHER INFORMATION: a, c, t, g, unknown or other

<400> SEQUENCE: 255

gaaggcctg agtccgagc tc 22

<210> SEQ ID NO 256
<211> LENGTH: 22
<212> TYPE: DNA
<213> ORGANISM: Homo sapiens
<220> FEATURE:
<221> NAME/KEY: modified_base
<222> LOCATION: (20)..(20)
<223> OTHER INFORMATION: a, c, t, g, unknown or other

<400> SEQUENCE: 256

caaccggtgg cgcattgcn tg 22

<210> SEQ ID NO 257
<211> LENGTH: 22
<212> TYPE: DNA
<213> ORGANISM: Homo sapiens
<220> FEATURE:
<221> NAME/KEY: modified_base
<222> LOCATION: (20)..(20)
<223> OTHER INFORMATION: a, c, t, g, unknown or other

<400> SEQUENCE: 257

-continued

aggaggaagg gcctgagtcn ca 22

<210> SEQ ID NO 258
<211> LENGTH: 22
<212> TYPE: DNA
<213> ORGANISM: Homo sapiens
<220> FEATURE:
<221> NAME/KEY: modified_base
<222> LOCATION: (20)..(20)
<223> OTHER INFORMATION: a, c, t, g, unknown or other

<400> SEQUENCE: 258

agctggagga ggaaggccn ct 22

<210> SEQ ID NO 259
<211> LENGTH: 22
<212> TYPE: DNA
<213> ORGANISM: Homo sapiens
<220> FEATURE:
<221> NAME/KEY: modified_base
<222> LOCATION: (20)..(20)
<223> OTHER INFORMATION: a, c, t, g, unknown or other

<400> SEQUENCE: 259

gcattgccac gaagcagcn cc 22

<210> SEQ ID NO 260
<211> LENGTH: 22
<212> TYPE: DNA
<213> ORGANISM: Homo sapiens
<220> FEATURE:
<221> NAME/KEY: modified_base
<222> LOCATION: (20)..(20)
<223> OTHER INFORMATION: a, c, t, g, unknown or other

<400> SEQUENCE: 260

attgccacga agcaggccan cg 22

<210> SEQ ID NO 261
<211> LENGTH: 22
<212> TYPE: DNA
<213> ORGANISM: Homo sapiens
<220> FEATURE:
<221> NAME/KEY: modified_base
<222> LOCATION: (20)..(20)
<223> OTHER INFORMATION: a, c, t, g, unknown or other

<400> SEQUENCE: 261

agaaccggag gacaaagtan ga 22

<210> SEQ ID NO 262
<211> LENGTH: 22
<212> TYPE: DNA
<213> ORGANISM: Homo sapiens
<220> FEATURE:
<221> NAME/KEY: modified_base
<222> LOCATION: (20)..(20)
<223> OTHER INFORMATION: a, c, t, g, unknown or other

<400> SEQUENCE: 262

tcaaccggtg ggcgattcn gt 22

<210> SEQ ID NO 263
<211> LENGTH: 22
<212> TYPE: DNA

-continued

```

<213> ORGANISM: Homo sapiens
<220> FEATURE:
<221> NAME/KEY: modified_base
<222> LOCATION: (20)..(20)
<223> OTHER INFORMATION: a, c, t, g, unknown or other

<400> SEQUENCE: 263
gaagctggag gaggaagggn gc                22

<210> SEQ ID NO 264
<211> LENGTH: 123
<212> TYPE: DNA
<213> ORGANISM: Artificial Sequence
<220> FEATURE:
<223> OTHER INFORMATION: Description of Artificial Sequence: Synthetic
      polynucleotide

<400> SEQUENCE: 264
ccaatgggga ggacatcgat gtcacctcca atgactaggg tgggcaacca caaaccacg      60
agggcagagt gctgcttgcg gctggccagg cccctgcgtg ggccaagct ggactctgg      120
cac                                          123

<210> SEQ ID NO 265
<211> LENGTH: 121
<212> TYPE: DNA
<213> ORGANISM: Artificial Sequence
<220> FEATURE:
<223> OTHER INFORMATION: Description of Artificial Sequence: Synthetic
      polynucleotide

<400> SEQUENCE: 265
cgagcagaag aagaagggct cccatcacat caaccgggtg cgcattgcca cgaagcaggc      60
caatggggag gacatcgatg tcacctccaa tgactagggg gggcaaccac aaaccacga      120
g                                          121

<210> SEQ ID NO 266
<211> LENGTH: 128
<212> TYPE: DNA
<213> ORGANISM: Artificial Sequence
<220> FEATURE:
<223> OTHER INFORMATION: Description of Artificial Sequence: Synthetic
      polynucleotide

<400> SEQUENCE: 266
ggaggacaaa gtacaaaagg cagaagctgg aggaggaagg gcctgagtcc gagcagaaga      60
agaagggtcc ccatcacatc aaccgggtgc gcattgccac gaagcaggcc aatggggagg      120
acatcgat                                     128

<210> SEQ ID NO 267
<211> LENGTH: 130
<212> TYPE: DNA
<213> ORGANISM: Artificial Sequence
<220> FEATURE:
<223> OTHER INFORMATION: Description of Artificial Sequence: Synthetic
      polynucleotide

<400> SEQUENCE: 267
agaagctgga ggaggaaggg cctgagtccg agcagaagaa gaagggtcc catcacatca      60
accggtggcg cattgccacg aagcaggcca atggggagga catcgatgtc acctccaatg      120

```

-continued

actaggggtgg 130

<210> SEQ ID NO 268
 <211> LENGTH: 125
 <212> TYPE: DNA
 <213> ORGANISM: Artificial Sequence
 <220> FEATURE:
 <223> OTHER INFORMATION: Description of Artificial Sequence: Synthetic polynucleotide

<400> SEQUENCE: 268

cctcagtctt cccatcaggc tctcagctca gcttgagtgt tgaggcccca gtggtgctc 60
 tgggggcctc ctgagtttct catctgtgcc cctccctccc tggcccaggt gaaggtgtgg 120
 ttcca 125

<210> SEQ ID NO 269
 <211> LENGTH: 129
 <212> TYPE: DNA
 <213> ORGANISM: Artificial Sequence
 <220> FEATURE:
 <223> OTHER INFORMATION: Description of Artificial Sequence: Synthetic polynucleotide

<400> SEQUENCE: 269

tcactgtgc ccctccctcc ctggcccagg tgaaggtgtg gttccagaac cggaggacaa 60
 agtacaaaacg gcagaagctg gaggaggaag ggcctgagtc cgagcagaag aagaagggt 120
 cccatcaca 129

<210> SEQ ID NO 270
 <211> LENGTH: 129
 <212> TYPE: DNA
 <213> ORGANISM: Artificial Sequence
 <220> FEATURE:
 <223> OTHER INFORMATION: Description of Artificial Sequence: Synthetic polynucleotide

<400> SEQUENCE: 270

ctccaatgac tagggtgggc aaccacaaac ccacgagggc agagtgtgc ttgctgctgg 60
 ccaggccct gcgtgggccc aagctggact ctggccactc cctggccagg ctttggggag 120
 gctggagt 129

<210> SEQ ID NO 271
 <211> LENGTH: 127
 <212> TYPE: DNA
 <213> ORGANISM: Artificial Sequence
 <220> FEATURE:
 <223> OTHER INFORMATION: Description of Artificial Sequence: Synthetic polynucleotide

<400> SEQUENCE: 271

ctgcttctg ctgcccagc cctgctgtg gcccaagctg gactctggcc actccctggc 60
 caggctttgg ggaggcctgg agtcatggcc ccacagggt tgaagcccgg ggcccatt 120
 gacagag 127

<210> SEQ ID NO 272
 <211> LENGTH: 25
 <212> TYPE: DNA
 <213> ORGANISM: Artificial Sequence
 <220> FEATURE:

-continued

<223> OTHER INFORMATION: Description of Artificial Sequence: Synthetic oligonucleotide

<400> SEQUENCE: 272

gaaattaata cgactcacta taggg 25

<210> SEQ ID NO 273
 <211> LENGTH: 126
 <212> TYPE: DNA
 <213> ORGANISM: Artificial Sequence
 <220> FEATURE:
 <223> OTHER INFORMATION: Description of Artificial Sequence: Synthetic polynucleotide

<400> SEQUENCE: 273

aaaaaagcac cgactcggcg ccactttttc aagttgataa cggactagcc ttattttaac 60
 ttgctatttc tagctctaaa acaacgacga gcgtgacacc accctatagt gagtcgtatt 120
 aatttc 126

<210> SEQ ID NO 274
 <211> LENGTH: 126
 <212> TYPE: DNA
 <213> ORGANISM: Artificial Sequence
 <220> FEATURE:
 <223> OTHER INFORMATION: Description of Artificial Sequence: Synthetic polynucleotide

<400> SEQUENCE: 274

aaaaaagcac cgactcggcg ccactttttc aagttgataa cggactagcc ttattttaac 60
 ttgctatttc tagctctaaa acgcaacaat taatagactg gacctatagt gagtcgtatt 120
 aatttc 126

<210> SEQ ID NO 275
 <211> LENGTH: 4677
 <212> TYPE: DNA
 <213> ORGANISM: Artificial Sequence
 <220> FEATURE:
 <223> OTHER INFORMATION: Description of Artificial Sequence: Synthetic polynucleotide

<400> SEQUENCE: 275

tctttcttgc gctatgacac ttccagcaaa aggtagggcg ggctgcgaga cggcttcccg 60
 gcgctgcatg caacaccgat gatgcttoga cccccgaag ctccctcggg gctgcatggg 120
 cgctccgatg ccgctccagg gcgagcgtg tttaaatagc caggcccccg attgcaaaga 180
 cattatagcg agctacaaaa gccatattca aacacctaga tcactaccac ttctacacag 240
 gccactcgag cttgtgatcg cactccgcta agggggcgcc tcttctctt cgtttcagtc 300
 acaaccgca aacatgtacc catacgtatg tccagattac gcttcgccga agaaaaagcg 360
 caagtgcaaa gcgtccgaca agaagtacag catcgccctg gacatcggca ccaactctgt 420
 gggtggggcc gtgatcaccg acgagtacaa ggtgcccagc aagaaattca aggtgctggg 480
 caacaccgac cggcacagca tcaagaagaa cctgatcggg gccctgctgt tcgacagcgg 540
 cgaaacagcc gaggccaccc ggctgaagag aaccgccaga agaagatata ccagacggaa 600
 gaaccggatc tgctatctgc aagagatctt cagcaacgag atggccaagg tggacgacag 660
 cttcttccac agactggaag agtccttctt ggtggaagag gataagaagc acgagcggca 720

-continued

ccccatcttc	ggcaacatcg	tggacgaggt	ggcctaccac	gagaagtacc	ccaccatcta	780
ccacctgaga	aagaaactgg	tggacagcac	cgacaaggcc	gacctgcggc	tgatctatct	840
ggccctggcc	cacatgatca	agttccgggg	ccacttctctg	atcgagggcg	acctgaacct	900
cgacaacagc	gacgtggaca	agctgttcat	ccagctgggtg	cagacctaca	accagctgtt	960
cgaggaaaac	cccatacaacg	ccagcggcgt	ggacgccaag	gccatcctgt	ctgccagact	1020
gagcaagagc	agacggctgg	aaaatctgat	cgcccagctg	cccggcgaga	agaagaatgg	1080
cctgttcggc	aacctgattg	cctgagcct	gggcctgacc	cccaacttca	agagcaactt	1140
cgacctggcc	gaggatgcca	aactgcagct	gagcaaggac	acctacgacg	acgacctgga	1200
caacctgctg	gcccagatcg	gcgaccagta	cgccgacctg	tttctggccg	ccaagaacct	1260
gtccgacgcc	atcctgctga	gcgacatcct	gagagtgaac	accgagatca	ccaaggcccc	1320
cctgagcgcc	tctatgatca	agagatacga	cgagcaccac	caggacctga	ccctgctgaa	1380
agctctctgt	cggcagcagc	tgccctgagaa	gtacaaagag	atcttctctg	accagagcaa	1440
gaacggctac	gcccggctaca	ttgacggcgg	agccagccag	gaagagtctt	acaagttcat	1500
caagcccac	ctggaaaaga	tggacggcac	cgaggaactg	ctcgtgaagc	tgaacagaga	1560
ggacctgctg	cggaagcagc	ggaccttcca	caacggcagc	atccccacc	agatccacct	1620
gggagagctg	cacgccattc	tgccggcgca	ggaagatttt	taccatttcc	tgaaggacaa	1680
ccgggaaaag	atcagagaaga	tcttgacctt	ccgcatcccc	tactacgtgg	gccctctggc	1740
caggggaaac	agcagattcg	cctggatgac	cagaaagagc	gaggaaacca	tcacccctg	1800
gaacttcgag	gaagtggctg	acaagggcgc	ttccgccag	agcttcatcg	agcggatgac	1860
caacttcgat	aagaacctgc	ccaacgagaa	ggtgctgccc	aagcacagcc	tgctgtacga	1920
gtacttcacc	gtgtataacg	agctgaccaa	agtgaatac	gtgaccgagg	gaatgagaaa	1980
gcccgccttc	ctgagcggcg	agcagaaaaa	ggccatcgtg	gacctgctgt	tcaagaccaa	2040
ccggaaaagt	accgtgaagc	agctgaaaga	ggactacttc	aagaaaatcg	agtgcttcca	2100
ctccgtggaa	atctccggcg	tggaagatcg	gttcaacgcc	tcctggggca	cataccacga	2160
tctgctgaaa	attatcaagg	acaaggactt	cctggacaat	gaggaaaacg	aggacattct	2220
ggaagatata	gtgctgaccc	tgacactggt	tgaggacaga	gagatgatcg	aggaaacggct	2280
gaaaacctat	gcccacctgt	tcgacgacaa	agtgatgaag	cagctgaagc	ggcggagata	2340
caccggctgg	ggcaggctga	gcccgaagct	gatcaacggc	atccgggaca	agcagtcagg	2400
caagacaatc	ctggatttcc	tgaagtcca	cggtctcgcc	aacagaaact	tcatgcagct	2460
gatccacgac	gacagcctga	cctttaaaga	ggacatccag	aaagcccagg	tgtccggcca	2520
gggcgatagc	ctgcacgagc	acattgccaa	tctggccggc	agcccccca	ttaagaaggg	2580
catcctcgag	acagtgaagg	tggtggacga	gctcgtgaaa	gtgatgggcc	ggcacaagcc	2640
cgagaacatc	gtgatcga	tggccagaga	gaaccagacc	accagaagg	gacagaagaa	2700
cagccgcgag	agaatgaagc	ggatcgaaga	gggcatcaaa	gagctgggca	gccagatcct	2760
gaaagaacac	cccgtggaaa	accccagct	gcagaacgag	aagctgtacc	tgtactacct	2820
gcagaatggg	cgggatatgt	acgtggacca	ggaactggac	atcaaccggc	tgtccgacta	2880
cgatgtggac	catatcgtgc	ctcagagctt	tctgaaggac	gactccatcg	acaacaaggt	2940
gctgaccaga	agcgacaaga	accggggcaa	gagcgacaac	gtgccctccg	aagaggtcgt	3000

-continued

```

gaagaagatg aagaactact ggcggcagct gctgaacgcc aagctgatta cccagagaaa 3060
gttcgacaat ctgaccaagg ccgagagagg cggcctgagc gaactggata aggccggctt 3120
catcaagaga cagctggtgg aaaccggca gatcacaag cactggcac agatcctgga 3180
ctcccggatg aactaagt acgacgagaa tgacaagctg atccgggaag tgaaagtgat 3240
caccctgaag tccaagctgg tgtccgattt ccggaaggat ttccagtttt acaaagtgcg 3300
cgagatcaac aactaccacc acgcccacga cgcctacctg aacgccgtcg tgggaaccgc 3360
cctgatcaaa aagtacccta agctggaaag cgagtctgtg tacggcgact acaaggtgta 3420
cgacgtgcgg aagatgatcg ccaagagcga gcaggaaatc ggcaaggcta ccgccaagta 3480
cttcttttac agcaacatca tgaacttttt caagaccgag attaccctgg ccaacggcga 3540
gatccggaag cggcctctga tcgagacaaa cggcgaacc ggggagatcg tgtgggataa 3600
gggcccggat tttgccaccg tgcggaaagt gctgagcatg cccaagtga atactgtgaa 3660
aaagaccgag gtgcagacag gcgcttcag caaagagtct atcctgcccc agaggaaacag 3720
cgataagctg atcgcacgaa agaaggactg ggaccctaag aagtacggcg gcttcgacag 3780
ccccaccgtg gcctattctg tgtctgtggt ggccaaagt gaaaagggca agtccaagaa 3840
actgaagagt gtgaagagc tctgtgggat caccatcatg gaaagaagca gcttcgagaa 3900
gaatcccacg gactttctgg aagccaaggg ctacaaagaa gtgaaaaagg acctgatcat 3960
caagctgect aagtactccc tgttcgagct ggaaaaacgc cggaagagaa tgctggcctc 4020
tgccggcgaa ctgcagaagg gaaacgaact ggccctgccc tccaaatatg tgaacttctt 4080
gtacctggcc agccactatg agaagctgaa gggctcccc gaggataatg agcagaaaca 4140
gctgtttgtg gaacagcaca agcactacct ggacgagatc atcgagcaga tcagcgagtt 4200
ctccaagaga gtgatcctgg ccgacgctaa tctggacaaa gtgctgtccg cctacaacaa 4260
gcaccgggat aagcccacga gagagcaggc cgagaatata atccacctgt ttaccctgac 4320
caatctggga gcccttccg ccttcaagta ctttgacacc acctcgacc ggaagaggta 4380
caccagcacc aaagaggctg tggacgccac cctgatccac cagagcatca ccggcctgta 4440
cgagacacgg atcgacctgt ctcagctggg aggcgacagc cccaagaaga agagaaaggt 4500
ggaggccagc taaggatccg gcaagactgg ccccgcttgg caacgcaaca gtgagcccct 4560
ccctagtgtg tttggggatg tgactatgta ttcgtgtgtt ggccaacggg tcaaccggaa 4620
cagattgata cccgccttgg catttctgt cagaatgtaa cgtcagttga tggctact 4677

```

<210> SEQ ID NO 276

<211> LENGTH: 3150

<212> TYPE: DNA

<213> ORGANISM: Artificial Sequence

<220> FEATURE:

<223> OTHER INFORMATION: Description of Artificial Sequence: Synthetic polynucleotide

<400> SEQUENCE: 276

```

tctttcttgc gctatgacac ttccagcaaa aggtagggcg ggctgcgaga cggcttcccg 60
gcgctgcatg caacaccgat gatgcttcca cccccgaag ctccctcggg gctgcatggg 120
cgctccgatg ccgctccagg gcgagcgtg tttaaatagc caggcccccg attgcaaaga 180
cattatagcg agctacaaaa gccatattca aacacctaga tcaactaccac ttctacacag 240
gccactcgag cttgtgatcg cactccgcta agggggcgcc tcttctctt cgtttcagtc 300

```

-continued

acaaccgca aacatgccta agaagaagag gaaggttaac acgattaaca tcgctaagaa	360
cgacttctct gacatcgaac tggtctgat cccgttcaac actctggctg accattacgg	420
tgagcgttta gctcgcgaac agtggocct tgagcatgag tcttacgaga tgggtgaagc	480
acgcttccgc aagatgtttg agcgtcaact taaagctggt gaggttgccg ataacgctgc	540
cgccaagcct ctcatcacta cctactccc taagatgatt gcacgcatca acgactggtt	600
tgaggaagtg aaagctaagc gcggcaagcg cccgacagcc ttccagtcc tgcaagaaat	660
caagccggaa gccgtagcgt acatcaccat taagaccact ctggcttgcc taaccagtgc	720
tgacaataca accgttcagg ctgtagcaag cgcaatcggc cgggccattg aggacgaggc	780
tcgcttcggt cgtatccgtg accttgaagc taagcacttc aagaaaaacg ttgaggaaca	840
actcaacaag cgcgtagggc acgtctacaa gaaagcattt atgcaagtgg tcgaggtgga	900
catgctctct aagggtctac tcggtggcga ggcgtggtct tcgtggcata aggaagactc	960
tattcatgta ggagtaacct gcatcgagat gctcattgag tcaaccggaa tggttagctt	1020
acaccgcaa aatgctggcg tagtaggtca agactctgag actatcgaac tcgcacctga	1080
atacgtgag gctatcgaac cccgtgcagg tgcgctggct ggcactctc cgatgtcca	1140
accttgcgta gttctccta agccgtggac tggcattact ggtgggtgct attgggctaa	1200
cggtcgtcgt cctctggcgc tgggtcgtac tcacagtaag aaagcactga tgcgctacga	1260
agacgtttac atgctgagg tgtacaaagc gattaacatt gcgcaaaaca ccgcatggaa	1320
aatcaacaag aaagtctag cgttcgcaa cgtaatcacc aagtggaagc attgtccggt	1380
cgaggacatc cctcggattg agcgtgaaga actcccgatg aaaccggaag acatcgacat	1440
gaatcctgag gctctcaccg cgtggaacg tgcgcccgt gctgtgtacc gcaaggacaa	1500
ggctcgaag tctcgcgta tcagccttga gttcatgctt gagcaagcca ataagtttgc	1560
taaccataag gccatctggt tcccttacia catggactgg cgcggctcgt tttacgctgt	1620
gtcaatgttc aaccgcaag gtaacgatat gaccaaagga ctgcttacgc tggcgaagg	1680
taaaccaatc ggtaaggaag gttactactg gctgaaaatc cacggtgcaa actgtgcggg	1740
tgctgacaag gttccgttcc ctgagcgcac caagttcatt gaggaaaacc acgagaacat	1800
catggcttgc gctaagtctc cactggagaa cacttgggtg gctgagcaag attctccgtt	1860
ctgcttcctt gcgttctgct ttgagtacgc tggggtacag caccacggcc tgagctataa	1920
ctgetccctt ccgctggcgt ttgacgggtc ttgctctggc atccagcact tctcccgat	1980
gctccgagat gaggtagggt gtcgcccggc taacttgctt cctagtgaac ccgttcagga	2040
catctacggg attgttgcta agaaagtcaa cgagattcta caagcagacg caatcaatgg	2100
gaccgataac gaagtagtta ccgtgaccga tgagaacact ggtgaaatct ctgagaaagt	2160
caagctgggc actaaggcac tggctggcca atggctggct tacgggtgta ctgcagtggt	2220
gactaagcgt tcagtcatga cgttgctta cgggtccaaa gagttcggct tccgtcaaca	2280
agtgtcggaa gataaccatc agccagctat tgattccggc aagggtctga tgttactca	2340
gccaatcag gctcctggat acatggctaa gctgatttgg gaatctgtga gcgtgacggg	2400
ggtagctcgc gttgaagcaa tgaactggct taagtctgct gctaagctgc tggctgctga	2460
ggtcaaatgag aagaagactg gagagattct tcgcaagcgt tgcgctgtgc attgggtaac	2520
tcctgatggt ttcctgtgtt ggcaggaata caagaagcct attcagacgc gcttgaacct	2580

-continued

```

gatgttctc ggtcagtcc gttacagcc taccattaac accaacaag atagcgagat 2640
tgatgcacac aacacaggagt ctggtatcgc tcctaacttt gtacacagcc aagacggtag 2700
ccaccttcgt aagactgtag tgtgggcaca cgagaagtac ggaatcgaat cttttgcact 2760
gattcacgac tccttcggta cgattccggc tgacgctgcg aacctgttca aagcagtgcg 2820
cgaaactatg gttgacacat atgagtcttg tgatgtactg gctgatttct acgaccagtt 2880
cgctgaccag ttgcacgagt ctcaattgga caaaatgcca gcacttccgg ctaaaggtaa 2940
cttgaacctc cgtgacatct tagagtggga cttecgcttc gcgtaaggat cgggcaagac 3000
tggccccgct tggcaacgca acagtgagcc cctccctagt gtgtttgggg atgtgactat 3060
gtattcgtgt gttggccaac gggtaacc ccaacagattg ataccgcct tggcatttcc 3120
tgtcagaatg taacgtcagt tgatggtagt 3150

```

```

<210> SEQ ID NO 277
<211> LENGTH: 125
<212> TYPE: DNA
<213> ORGANISM: Artificial Sequence
<220> FEATURE:
<223> OTHER INFORMATION: Description of Artificial Sequence: Synthetic
        polynucleotide
<220> FEATURE:
<221> NAME/KEY: modified_base
<222> LOCATION: (23)..(42)
<223> OTHER INFORMATION: a, c, t, g, unknown or other

```

<400> SEQUENCE: 277

```

gaaattaata cgactcacta tannnnnnnn nnnnnnnnnn nngttttaga gctagaata 60
gcaagttaaa ataaggtag tccggtatca acttgaaaaa gtggcaccga gtcggtgctt 120
ttttt 125

```

```

<210> SEQ ID NO 278
<211> LENGTH: 8452
<212> TYPE: DNA
<213> ORGANISM: Artificial Sequence
<220> FEATURE:
<223> OTHER INFORMATION: Description of Artificial Sequence: Synthetic
        polynucleotide

```

<400> SEQUENCE: 278

```

tgcggtatth cacaccgcat cagggtggcac ttttcgggga aatgtgctgc gaaccctat 60
ttgtttatth ttetaatac attcaaatat gtatccgctc atgagattat caaaaaggat 120
cttcacctag atccttttaa attaaaaatg aagttttaa tcaatctaaa gtatatatga 180
gtaaacttgg tctgacagtt accaatgctt aatcagtgag gcacctatct cagcgatctg 240
tctatttcgt tcattccatag ttgcctgact ccccgctcgt tagataacta cgatacggga 300
gggcttacca tctggcccca gtgctgcaat gataccgca gaccacgct caccgctcc 360
agatttatca gcaataaacc agccagccgg aaggccgag cgcagaagtg gtcctgcaac 420
tttatccgcc tccatccagt ctattaattg ttgccgggaa gctagagtaa gtagttcgcc 480
agttaatagt ttgcgcaacg ttgttgcctat tgctacaggc atcgtggtgt cagcgtcgtc 540
gtttggtagt gcttcattca gctccggctc ccaacgatca aggcgagtta catgatcccc 600
catgttgtgc aaaaaagcgg ttgactcctt cggctcctcg atcgttgtca gaagtaagtt 660
ggccgcagtg ttatcactca tggttatggc agcactgcat aattctctta ctgtcatgcc 720

```

-continued

atccgtaaga tgctttctg tgactggtga gtactcaacc aagtcattct gagaatagtg 780
tatgctggcga ccgagttgct cttgccggc gtcaatacgg gataataccg cgccacatag 840
cagaacttta aaagtgtca tcattgaaa acgttcttcg gggcgaaaac tctcaaggat 900
cttaccgctg ttgagatoca gttcgatgta acccactcgt gcaccaact gatcttcagc 960
atcttttact ttcaccagcg tttctgggtg agcaaaaaca ggaaggcaaa atgccgcaaa 1020
aaagggaata agggcgacac ggaatggtg aatactcata ctcttccttt ttcaatatta 1080
ttgaagcatt taccaggggt attgtctcat gacaaaaatc ccttaacgtg agttttcgtt 1140
ccactgagcg tcagaccccg tagaaaagat caaaggatct tcttgagatc cttttttct 1200
gcgctaatc tgctgcttgc aaacaaaaa accacgcta ccagcggtagg ttgttttgc 1260
ggatcaagag ctaccaactc tttttccgaa ggtaactggc ttcagcagag cgagatacc 1320
aaatactggt cttctagtgt agccgtagt aggccaccac ttcaagaact ctgtagcacc 1380
gcctacatac ctcgctctgc taactcgtt accagtggct gttgccagtg gcgataagt 1440
gtgtcttacc ggggttgact caagacgata gttaccggat aaggcgcagc ggtcgggctg 1500
aacggggggt tcgtgcacac agcccagctt ggagcgaacg acctacacc aactgagata 1560
cctacagcgt gagctatgag aaagcggcac gcttcccga gggagaaaag cgacaggt 1620
tccgtaagc ggcagggtc gaacaggaga gcgcacgag gagcttccag ggggaaacgc 1680
ctggtatctt tatagtcctg tcgggttctg ccacctctga cttgagcgtc gatttttctg 1740
atgctcgtca gggggggcga gcctatggaa aaacgccagc aacgcggcct ttttaccggt 1800
cctggccttt tgctggcctt ttgctccat gttctttct gcgttatccc ctgattctgt 1860
ggataaccgt attaccgct ttgagtgagc tgataccgct cgccgcagcc gaacgaccga 1920
gcgcagcagc tcagtgcagc aggaagcggc cgtgaggct tgacatgatt ggtgcgtatg 1980
tttgatgaa gctacaggac tgatttggcg ggctatgagg gggggggaag ctctggaag 2040
gccgcgatgg ggcgcggcgc gtccagaag cgccatacgg cccgctggcg gcacccatcc 2100
ggtataaaag cccgcgccc cgaacgggtga cctccacttt cagcgacaaa cgagcactta 2160
tacatacgcg actattctgc cgtatacat aaccactcag ctagcttaag atccatcaa 2220
gcttgcatgc cgggcgcgccc agaaggagcg cagccaaacc aggatgatgt ttgatgggt 2280
atgtgagcac ttgcaaccct taccgggaag cccctggccc cacaaaggct aggcgccaat 2340
gcaagcagtt cgcagcagc cctggagcg gtgcctcct gataaacggc ccaggggggc 2400
tatgttcttt acttttttac aagagaagtc actcaacatc ttaaatggc caggtgagtc 2460
gacgagcaag cccggcgat caggcagcgt gcttgagatc ttgacttgc acgcccgc 2520
tgtgtcgaag aaggcttttg gctcctctgt cgtgtctca agcagcatct aaccctcgt 2580
cgccgtttcc atttgagga gattcaggt accatgtacc catacagatg tccagattac 2640
gcttcgcccga agaaaaagcg caaggtcgaa gcgtccgaca agaagtacag catcgccctg 2700
gacatcggca ccaactctgt gggctgggccc gtgatcaccg acgagtacaa ggtgccagc 2760
aagaaattca aggtgctggg caacaccgac cggcacagca tcaagaagaa cctgatcgg 2820
gcccctgctg tcgacagcg cgaacagcc gaggccccc ggctgaagag aaccgcccga 2880
agaagataca ccagacggaa gaaccggatc tgctatctgc aagagatctt cagcaacgag 2940
atggccaagg tggacgacag cttctccac agactggaag agtcctcct ggtggaagag 3000

-continued

gataagaagc acgagcggca ccccatcttc ggcaacatcg tggacgaggt ggctaccac 3060
gagaagtaacc ccaccatcta ccacctgaga aagaaactgg tggacagcac cgacaaggcc 3120
gacctgcggc tgatctatct ggccttggcc cacatgatca agttccgggg ccaacttctg 3180
atcgaggcgc acctgaaccc cgacaacagc gacgtggaca agctgttcat ccagctggtg 3240
cagacctaca accagctggt cgaggaaaac cccatcaacg ccagcggcgt ggacgccaag 3300
gccatcctgt ctgccagact gagcaagagc agacggctgg aaaatctgat cgcccagctg 3360
cccggcgaga agaagaatgg cctgttcggc aacctgattg ccctgagcct gggcctgacc 3420
cccaacttca agagcaactt cgacctggcc gaggatgcca aactgcagct gagcaaggac 3480
acctacgacg acgacctgga caacctgctg gcccagatcg gcgaccagta cgccgacctg 3540
tttctggcgg ccaagaacct gtccgacgcc atcctgctga gcgacatcct gagagtgaac 3600
accgagatca ccaaggcccc cctgagcggc tctatgatca agagatacga cgagcaccac 3660
caggacctga ccctgctgaa agctctcgtg cggcagcagc tgccctgagaa gtacaaagag 3720
atcttctctg accagagcaa gaacggctac gccggctaca ttgacggcgg agccagccag 3780
gaagagttct acaagttcat caagccatc ctggaaaaga tggacggcac cgaggaactg 3840
ctcgtgaagc tgaacagaga ggacctgctg cggaaagcagc ggaccttcga caacggcagc 3900
atccccacc agatccaact gggagagctg cacgccatc tgcggcgcca ggaagatctt 3960
taccattcc tgaaggacaa ccgggaaaag atcgagaaga tcctgacctt ccgcatcccc 4020
tactacgtgg gccctctggc caggggaaac agcagattcg cctggatgac cagaaagagc 4080
gaggaaacca tccccctg gaacttcgag gaagtgggtg acaagggcgc ttccgcccag 4140
agcttcatcg agcggatgac caacttcgat aagaacctgc ccaacgagaa ggtgctgccc 4200
aagcacagcc tgcgttacga gtacttcacc gtgtataacg agctgaccaa agtgaatac 4260
gtgaccgagg gaatgagaaa gcccgcttc ctgagcggcg agcagaaaaa ggccatcgtg 4320
gacctgctgt tcaagaccaa ccgaaagtg accgtgaagc agctgaaaga ggactacttc 4380
aagaaaatcg agtgcctoga ctccgtggaa atctccggcg tggaaagatcg gttcaacgcc 4440
tccctgggca cataccacga tctgctgaaa attatcaagg acaaggactt cctggacaat 4500
gaggaaaacg aggacattct ggaagatata gtgctgaccc tgacactggt tgaggacaga 4560
gagatgatcg aggaacggct gaaaacctat gcccacctgt tcgacgacaa agtgatgaag 4620
cagctgaagc ggcggagata caccggctgg ggcaggtga gccggaagct gatcaacggc 4680
atccgggaca agcagtcggc caagacaatc ctggatttcc tgaagtccga cggtctgcc 4740
aacagaaact tcatgcagct gatccacgac gacagcctga cctttaaaga ggacatccag 4800
aaagcccagg tgtccggcca gggcgatagc ctgcacgagc acattgcca tctggccggc 4860
agcccccca ttaagaagg catcctgcag acagtgaagg tgggtgacga gctcgtgaaa 4920
gtgatgggcc ggcacaagcc cgagaacatc gtgatcgaaa tggccagaga gaaccagacc 4980
accagaagg gacagaagaa cagcccgagc agaatgaagc ggatcgaaga gggcatcaaa 5040
gagctgggca gccagatcct gaaagaacac cccgtggaaa acaccagct gcagaacgag 5100
aagctgtacc tgtactaact gcagaatggc cgggatatgt acgtggacca ggaactggac 5160
atcaaccggc tgtccgacta cgatgtggac catatcgtgc ctgagagctt tctgaaggac 5220
gactccatcg acaacaaggt gctgaccaga agcgacaaga accggggcaa gagcgacaac 5280

-continued

gtgccctccg aagaggtcgt gaagaagatg aagaactact ggccgagct gctgaacgcc 5340
aagctgatta cccagagaaa gttcgacaat ctgaccaagg ccgagagagg cggcctgagc 5400
gaactggata aggcggcgtt catcaagaga cagctggagg aaaccggca gatcacaagg 5460
cacgtggcac agatcctgga ctcccgatg aacactaagt acgacgagaa tgacaagctg 5520
atccgggaag tgaaagtgat caccctgaag tccaagctgg tgtccgattt ccggaaggat 5580
ttccagtttt acaaaagtgc cgagatcaac aactaccacc acgcccacga cgcctacctg 5640
aacgcctgcg tgggaaccgc cctgatcaaa aagtacccta agctggaaaag cgagttcgtg 5700
tacggcgact acaaggtgta cgacgtgcgg aagatgatcg ccaagagcga gcaggaaatc 5760
ggcaaggcta ccgccaagta cttctctctac agcaacatca tgaacttttt caagaccgag 5820
attaccctgg ccaacggcga gatccggaag cggcctctga tcgagacaaa cggcgaacc 5880
ggggagatcg tgtgggataa gggccgggat ttgcccaccg tgcggaaaag gctgagcatg 5940
ccccaaagtga atatcgtgaa aaagaccgag gtgcagacag gcggcttcag caaagagtct 6000
atcctgcccc agaggaacag cgataagctg atcgccagaa agaaggactg ggaccctaag 6060
aagtacggcg gcttcgacag ccccaccgtg gcctattctg tgcctgggtg ggccaaagtg 6120
gaaaagggca agtccaagaa actgaagagt gtgaaagagc tgctggggat caccatcatg 6180
gaaagaagca gcttcgagaa gaatcccacg gactttctgg aagccaaggg ctacaaagaa 6240
gtgaaaaagg acctgatcat caagctgcct aagtaactcc tggctcgagct ggaaaaaggc 6300
cggaaagagaa tgctggcctc tgccggcgaa ctgcagaagg gaaacgaact ggccctgccc 6360
tccaaatatg tgaacttctc gtacctggcc agccactatg agaagctgaa gggctcccc 6420
gaggataatg agcagaaaca gctgtttgtg gaacagcaca agcactacct ggacgagatc 6480
atcgagcaga tcagcgagtt ctccaagaga gtgatcctgg ccgacgctaa tctggacaaa 6540
gtgctgtccg cctacaacaa gcaccgggat aagcccacga gagagcaggc cgagaatatc 6600
atccacctgt ttaccctgac caactctgga gcccctgccc ccttcaagta ctttgacacc 6660
accatcgacc ggaagaggta caccagcacc aaagagggtc tggacgccac cctgatccac 6720
cagagcatca ccggcctgta cgagacacgg atcgacctgt ctacagctggg aggcgacagc 6780
cccaagaaga agagaaagggt ggaggccagc taacatatga ttcgaatgct tttcttgccg 6840
tatgacactt ccagcaaaag gttagggcggg ctgcgagacg gcttcccggc gctgcatgca 6900
acaccgatga tgettgcacc ccccgaagct ccttcggggc tgcattggggc ctccgatgcc 6960
gctccagggc gagcgctggt taaatagcca gcccctcgat tgcaaagaca ttatagcgag 7020
ctaccaaagc catattcaaa cacctagatc actaccactt ctacacaggc cactcgagct 7080
tgtgatcgca ctccgctaag gggggcctc ttcctctctg tttcagtcac aaccgcgaaa 7140
catgacacaa gaatccctgt tacttctcga ccgtattgat tcggatgatt cctacgcgag 7200
cctgcggaac gaccaggaat tctgggagggt gagtcgacga gcaagccggc cggatcaggc 7260
agcgtgcttg cagatttgac ttgcaacgcc cgcattgtgt cgacgaaggc ttttggtcc 7320
tctgtcgtg tctcaagcag catctaacc cgcgtcggc tttccatttg cagccgctgg 7380
cccgcggagc cctggaggag ctccggctgc cggtgccgcc ggtgctgagg gtgcccggcg 7440
agagacacaa ccccgtagctg gtcggcgagc ccggcccggg gatcaagctg ttcggcgagc 7500
actggtgcgg tccggagagc ctccgctcgg agtcggaggc gtacgcggtc ctggcggagc 7560

-continued

```

ccccggtgcc ggtgccccgc ctctcgggcc gggcgagct gggccccgc accggagcct 7620
ggccgtggcc ctacctggtg atgagccgga tgaccggcac cacctggcgg tccgcgatgg 7680
acggcacgac cgaccggaac gcgctgctcg ccttggcccc cgaactcggc cgggtgctcg 7740
gccggctgca cagggtgccc ctgaccggga acaccgtgct cccccccat tccgaggtct 7800
tccccggaact gctgcgggaa cgccgcgccc cgaccgtcga ggaccaccgc ggggtggggct 7860
acctctcgcc ccggtgctg gaccgcctgg aggactggct gccggacgtg gacacgtcgc 7920
tggccggccc cgaacccccg ttctgccacg ggcacctgca cgggaccaac atcttctgtg 7980
acctggcccc gaccgaggtc accgggatcg tcgacttcac cgacgtctat gcgggagact 8040
cccgctacag cctggtgcaa ctgcatctca acgccttcgg gggcgaccgc gagatcctgg 8100
ccgcgctgct cgaccggggc cagtggaaac ggaccgagga ctctgccccg gaactgctcg 8160
ccttcacctt cctgcacgac ttcgaggtgt tcgaggagac cccgctggat ctctccggct 8220
tcaccgatcc ggaggaactg gcgcagttcc tctgggggcc gccggacacc gccccggcgc 8280
cctgataaag atccggcaag actggccccg cttggcaacg caacagtgag cccctcccta 8340
gtgtgtttgg ggatgtgact atgtattcgt gtgttgcca acgggtcaac ccgaacagat 8400
tgataccccg cttggcattt cctgtcagaa tgtaacgtca gttgatggta ct 8452

```

```

<210> SEQ ID NO 279
<211> LENGTH: 102
<212> TYPE: DNA
<213> ORGANISM: Artificial Sequence
<220> FEATURE:
<223> OTHER INFORMATION: Description of Artificial Sequence: Synthetic
        polynucleotide

```

```

<400> SEQUENCE: 279
gttttagagc tatgctgttt tgaatggtcc caaaacggaa gggcctgagt ccgagcagaa 60
gaagaagttt tagagctatg ctgttttgaa tggteccaaa ac 102

```

```

<210> SEQ ID NO 280
<211> LENGTH: 100
<212> TYPE: DNA
<213> ORGANISM: Homo sapiens
<400> SEQUENCE: 280

```

```

cggaggacaa agtacaaaac gcagaagctg gaggaggaag ggcctgagtc cgagcagaag 60
aagaagggct cccatcacat caaccgggtg cgcattgcca 100

```

```

<210> SEQ ID NO 281
<211> LENGTH: 50
<212> TYPE: DNA
<213> ORGANISM: Homo sapiens
<400> SEQUENCE: 281

```

```

agctggagga ggaagggcct gagtccgagc agaagaagaa gggctcccac 50

```

```

<210> SEQ ID NO 282
<211> LENGTH: 30
<212> TYPE: RNA
<213> ORGANISM: Artificial Sequence
<220> FEATURE:
<223> OTHER INFORMATION: Description of Artificial Sequence: Synthetic
        oligonucleotide

```

-continued

<400> SEQUENCE: 282

gaguccgagc agaagaagaa guuuuagagc 30

<210> SEQ ID NO 283

<211> LENGTH: 49

<212> TYPE: DNA

<213> ORGANISM: Artificial Sequence

<220> FEATURE:

<223> OTHER INFORMATION: Description of Artificial Sequence: Synthetic oligonucleotide

<400> SEQUENCE: 283

agctggagga ggaagggcct gagtccgagc agaagagaag ggctcccat 49

<210> SEQ ID NO 284

<211> LENGTH: 53

<212> TYPE: DNA

<213> ORGANISM: Homo sapiens

<400> SEQUENCE: 284

ctggaggagg aagggcctga gtccgagcag aagaagaagg gctcccatca cat 53

<210> SEQ ID NO 285

<211> LENGTH: 52

<212> TYPE: DNA

<213> ORGANISM: Homo sapiens

<400> SEQUENCE: 285

ctggaggagg aagggcctga gtccgagcag aagagaaggg ctcccatcac at 52

<210> SEQ ID NO 286

<211> LENGTH: 54

<212> TYPE: DNA

<213> ORGANISM: Homo sapiens

<400> SEQUENCE: 286

ctggaggagg aagggcctga gtccgagcag aagaagaagg ggctcccatc acat 54

<210> SEQ ID NO 287

<211> LENGTH: 50

<212> TYPE: DNA

<213> ORGANISM: Homo sapiens

<400> SEQUENCE: 287

ctggaggagg aagggcctga gtccgagcag aagaagggct cccatcacat 50

<210> SEQ ID NO 288

<211> LENGTH: 47

<212> TYPE: DNA

<213> ORGANISM: Homo sapiens

<400> SEQUENCE: 288

ctggaggagg aagggcctga gcccgagcag aagggtccc atcacat 47

<210> SEQ ID NO 289

<211> LENGTH: 66

<212> TYPE: DNA

<213> ORGANISM: Artificial Sequence

<220> FEATURE:

<223> OTHER INFORMATION: Description of Artificial Sequence: Synthetic oligonucleotide

-continued

<220> FEATURE:
<223> OTHER INFORMATION: Description of Combined DNA/RNA Molecule:
Synthetic oligonucleotide
<220> FEATURE:
<221> NAME/KEY: modified_base
<222> LOCATION: (1)..(20)
<223> OTHER INFORMATION: a, c, t, g, unknown or other

<400> SEQUENCE: 289

nnnnnnnnnn nnnnnnnnnn guuuuagagc uagaaaauagc aaguuaaaau aaggctagtc 60

cguuuu 66

<210> SEQ ID NO 290
<211> LENGTH: 20
<212> TYPE: RNA
<213> ORGANISM: Artificial Sequence
<220> FEATURE:
<223> OTHER INFORMATION: Description of Artificial Sequence: Synthetic
oligonucleotide

<400> SEQUENCE: 290

gaguccgagc agaagaagaa 20

<210> SEQ ID NO 291
<211> LENGTH: 20
<212> TYPE: RNA
<213> ORGANISM: Artificial Sequence
<220> FEATURE:
<223> OTHER INFORMATION: Description of Artificial Sequence: Synthetic
oligonucleotide

<400> SEQUENCE: 291

gacaucgaug uccucccau 20

<210> SEQ ID NO 292
<211> LENGTH: 20
<212> TYPE: RNA
<213> ORGANISM: Artificial Sequence
<220> FEATURE:
<223> OTHER INFORMATION: Description of Artificial Sequence: Synthetic
oligonucleotide

<400> SEQUENCE: 292

gucaccucca augacuaggg 20

<210> SEQ ID NO 293
<211> LENGTH: 20
<212> TYPE: RNA
<213> ORGANISM: Artificial Sequence
<220> FEATURE:
<223> OTHER INFORMATION: Description of Artificial Sequence: Synthetic
oligonucleotide

<400> SEQUENCE: 293

auuggguguu cagggcagag 20

<210> SEQ ID NO 294
<211> LENGTH: 20
<212> TYPE: RNA
<213> ORGANISM: Artificial Sequence
<220> FEATURE:
<223> OTHER INFORMATION: Description of Artificial Sequence: Synthetic
oligonucleotide

<400> SEQUENCE: 294

-continued

guggcgagag gggccgagau 20

<210> SEQ ID NO 295
<211> LENGTH: 20
<212> TYPE: RNA
<213> ORGANISM: Artificial Sequence
<220> FEATURE:
<223> OTHER INFORMATION: Description of Artificial Sequence: Synthetic
oligonucleotide

<400> SEQUENCE: 295

ggggccgaga ugggguuuc 20

<210> SEQ ID NO 296
<211> LENGTH: 20
<212> TYPE: RNA
<213> ORGANISM: Artificial Sequence
<220> FEATURE:
<223> OTHER INFORMATION: Description of Artificial Sequence: Synthetic
oligonucleotide

<400> SEQUENCE: 296

gugccauuag cuaaaugcau 20

<210> SEQ ID NO 297
<211> LENGTH: 20
<212> TYPE: RNA
<213> ORGANISM: Artificial Sequence
<220> FEATURE:
<223> OTHER INFORMATION: Description of Artificial Sequence: Synthetic
oligonucleotide

<400> SEQUENCE: 297

guaccaccca caggugccag 20

<210> SEQ ID NO 298
<211> LENGTH: 20
<212> TYPE: RNA
<213> ORGANISM: Artificial Sequence
<220> FEATURE:
<223> OTHER INFORMATION: Description of Artificial Sequence: Synthetic
oligonucleotide

<400> SEQUENCE: 298

gaaagccucu gggccaggaa 20

<210> SEQ ID NO 299
<211> LENGTH: 48
<212> TYPE: DNA
<213> ORGANISM: Artificial Sequence
<220> FEATURE:
<223> OTHER INFORMATION: Description of Artificial Sequence: Synthetic
oligonucleotide

<400> SEQUENCE: 299

ctggaggagg aagggcctga gtccgagcag aagaagaagg gctcccat 48

<210> SEQ ID NO 300
<211> LENGTH: 20
<212> TYPE: RNA
<213> ORGANISM: Artificial Sequence
<220> FEATURE:
<223> OTHER INFORMATION: Description of Artificial Sequence: Synthetic
oligonucleotide

-continued

<400> SEQUENCE: 300

gaguccgagc agaagaagau 20

<210> SEQ ID NO 301

<211> LENGTH: 20

<212> TYPE: RNA

<213> ORGANISM: Artificial Sequence

<220> FEATURE:

<223> OTHER INFORMATION: Description of Artificial Sequence: Synthetic
oligonucleotide

<400> SEQUENCE: 301

gaguccgagc agaagaagua 20

<210> SEQ ID NO 302

<211> LENGTH: 20

<212> TYPE: RNA

<213> ORGANISM: Artificial Sequence

<220> FEATURE:

<223> OTHER INFORMATION: Description of Artificial Sequence: Synthetic
oligonucleotide

<400> SEQUENCE: 302

gaguccgagc agaagaacaa 20

<210> SEQ ID NO 303

<211> LENGTH: 20

<212> TYPE: RNA

<213> ORGANISM: Artificial Sequence

<220> FEATURE:

<223> OTHER INFORMATION: Description of Artificial Sequence: Synthetic
oligonucleotide

<400> SEQUENCE: 303

gaguccgagc agaagaugaa 20

<210> SEQ ID NO 304

<211> LENGTH: 20

<212> TYPE: RNA

<213> ORGANISM: Artificial Sequence

<220> FEATURE:

<223> OTHER INFORMATION: Description of Artificial Sequence: Synthetic
oligonucleotide

<400> SEQUENCE: 304

gaguccgagc agaaguagaa 20

<210> SEQ ID NO 305

<211> LENGTH: 20

<212> TYPE: RNA

<213> ORGANISM: Artificial Sequence

<220> FEATURE:

<223> OTHER INFORMATION: Description of Artificial Sequence: Synthetic
oligonucleotide

<400> SEQUENCE: 305

gaguccgagc agaugaagaa 20

<210> SEQ ID NO 306

<211> LENGTH: 20

<212> TYPE: RNA

<213> ORGANISM: Artificial Sequence

<220> FEATURE:

-continued

<223> OTHER INFORMATION: Description of Artificial Sequence: Synthetic
oligonucleotide

<400> SEQUENCE: 306

gaguccgagc acaagaagaa 20

<210> SEQ ID NO 307
<211> LENGTH: 20
<212> TYPE: RNA
<213> ORGANISM: Artificial Sequence
<220> FEATURE:
<223> OTHER INFORMATION: Description of Artificial Sequence: Synthetic
oligonucleotide

<400> SEQUENCE: 307

gaguccgagg agaagaagaa 20

<210> SEQ ID NO 308
<211> LENGTH: 20
<212> TYPE: RNA
<213> ORGANISM: Artificial Sequence
<220> FEATURE:
<223> OTHER INFORMATION: Description of Artificial Sequence: Synthetic
oligonucleotide

<400> SEQUENCE: 308

gaguccgugc agaagaagaa 20

<210> SEQ ID NO 309
<211> LENGTH: 20
<212> TYPE: RNA
<213> ORGANISM: Artificial Sequence
<220> FEATURE:
<223> OTHER INFORMATION: Description of Artificial Sequence: Synthetic
oligonucleotide

<400> SEQUENCE: 309

gagucggagc agaagaagaa 20

<210> SEQ ID NO 310
<211> LENGTH: 20
<212> TYPE: RNA
<213> ORGANISM: Artificial Sequence
<220> FEATURE:
<223> OTHER INFORMATION: Description of Artificial Sequence: Synthetic
oligonucleotide

<400> SEQUENCE: 310

gagaccgagc agaagaagaa 20

<210> SEQ ID NO 311
<211> LENGTH: 24
<212> TYPE: DNA
<213> ORGANISM: Artificial Sequence
<220> FEATURE:
<223> OTHER INFORMATION: Description of Artificial Sequence: Synthetic
oligonucleotide

<400> SEQUENCE: 311

aatgacaagc ttgctagcgg tggg 24

<210> SEQ ID NO 312
<211> LENGTH: 39
<212> TYPE: DNA

-continued

<213> ORGANISM: Artificial Sequence
<220> FEATURE:
<223> OTHER INFORMATION: Description of Artificial Sequence: Synthetic
oligonucleotide

<400> SEQUENCE: 312

aaaacggaag ggcctgagtc cgagcagaag aagaagttt 39

<210> SEQ ID NO 313
<211> LENGTH: 39
<212> TYPE: DNA
<213> ORGANISM: Artificial Sequence
<220> FEATURE:
<223> OTHER INFORMATION: Description of Artificial Sequence: Synthetic
oligonucleotide

<400> SEQUENCE: 313

aaacaggggc cgagattggg tgttcagggc agaggtttt 39

<210> SEQ ID NO 314
<211> LENGTH: 38
<212> TYPE: DNA
<213> ORGANISM: Artificial Sequence
<220> FEATURE:
<223> OTHER INFORMATION: Description of Artificial Sequence: Synthetic
oligonucleotide

<400> SEQUENCE: 314

aaaacggaag ggcctgagtc cgagcagaag aagaagtt 38

<210> SEQ ID NO 315
<211> LENGTH: 40
<212> TYPE: DNA
<213> ORGANISM: Artificial Sequence
<220> FEATURE:
<223> OTHER INFORMATION: Description of Artificial Sequence: Synthetic
oligonucleotide

<400> SEQUENCE: 315

aacggagggga ggggcacaga tgagaaactc agggtttttag 40

<210> SEQ ID NO 316
<211> LENGTH: 38
<212> TYPE: DNA
<213> ORGANISM: Homo sapiens

<400> SEQUENCE: 316

agcccttett cttctgctcg gactcaggcc cttcctcc 38

<210> SEQ ID NO 317
<211> LENGTH: 40
<212> TYPE: DNA
<213> ORGANISM: Artificial Sequence
<220> FEATURE:
<223> OTHER INFORMATION: Description of Artificial Sequence: Synthetic
oligonucleotide

<400> SEQUENCE: 317

cagggagggga ggggcacaga tgagaaactc aggaggcccc 40

<210> SEQ ID NO 318
<211> LENGTH: 80
<212> TYPE: DNA
<213> ORGANISM: Artificial Sequence

-continued

<211> LENGTH: 33
<212> TYPE: DNA
<213> ORGANISM: Homo sapiens

<400> SEQUENCE: 324

tcgtggcaat gcgccaccgg ttgatgtgat ggg 33

<210> SEQ ID NO 325
<211> LENGTH: 33
<212> TYPE: DNA
<213> ORGANISM: Homo sapiens

<400> SEQUENCE: 325

tccagcttct gccgtttgta ctttgtcttc egg 33

<210> SEQ ID NO 326
<211> LENGTH: 33
<212> TYPE: DNA
<213> ORGANISM: Homo sapiens

<400> SEQUENCE: 326

ggagggaggg gcacagatga gaaactcagg agg 33

<210> SEQ ID NO 327
<211> LENGTH: 33
<212> TYPE: DNA
<213> ORGANISM: Homo sapiens

<400> SEQUENCE: 327

aggggccgag attgggtggt cagggcagag agg 33

<210> SEQ ID NO 328
<211> LENGTH: 54
<212> TYPE: DNA
<213> ORGANISM: Artificial Sequence
<220> FEATURE:
<223> OTHER INFORMATION: Description of Artificial Sequence: Synthetic
oligonucleotide

<400> SEQUENCE: 328

aacaccgggt cttcgagaag acctgtttta gagctagaaa tagcaagtta aaat 54

<210> SEQ ID NO 329
<211> LENGTH: 54
<212> TYPE: DNA
<213> ORGANISM: Artificial Sequence
<220> FEATURE:
<223> OTHER INFORMATION: Description of Artificial Sequence: Synthetic
oligonucleotide

<400> SEQUENCE: 329

caaaacgggt cttcgagaag acgttttaga gctatgctgt tttgaatggg ccca 54

<210> SEQ ID NO 330
<211> LENGTH: 33
<212> TYPE: DNA
<213> ORGANISM: Mus musculus

<400> SEQUENCE: 330

caagcactga gtgccattag ctaaattgcat agg 33

<210> SEQ ID NO 331

-continued

```

<211> LENGTH: 33
<212> TYPE: DNA
<213> ORGANISM: Mus musculus

<400> SEQUENCE: 331
aatgcatagg gtaccacca caggtgccag ggg                33

<210> SEQ ID NO 332
<211> LENGTH: 33
<212> TYPE: DNA
<213> ORGANISM: Mus musculus

<400> SEQUENCE: 332
acacacatgg gaaagcctct gggccaggaa agg                33

<210> SEQ ID NO 333
<211> LENGTH: 37
<212> TYPE: DNA
<213> ORGANISM: Homo sapiens

<400> SEQUENCE: 333
ggaggaggta gtatacagaa acacagagaa gtagaat            37

<210> SEQ ID NO 334
<211> LENGTH: 37
<212> TYPE: DNA
<213> ORGANISM: Homo sapiens

<400> SEQUENCE: 334
agaatgtaga ggagtcacag aaactcagca ctagaaa            37

<210> SEQ ID NO 335
<211> LENGTH: 98
<212> TYPE: DNA
<213> ORGANISM: Artificial Sequence
<220> FEATURE:
<223> OTHER INFORMATION: Description of Artificial Sequence: Synthetic
        oligonucleotide

<400> SEQUENCE: 335
ggacgaaaca ccggaacctat tcaaaacagc atagcaagtt aaaataaggc tagtccgta    60
tcaacttgaa aaagtggcac cgagtcggtg cttttttt                98

<210> SEQ ID NO 336
<211> LENGTH: 186
<212> TYPE: DNA
<213> ORGANISM: Artificial Sequence
<220> FEATURE:
<223> OTHER INFORMATION: Description of Artificial Sequence: Synthetic
        polynucleotide

<400> SEQUENCE: 336
ggacgaaaca cggtagtat taagtattgt tttatggctg ataaatttct ttgaatttct    60
ccttgattat ttgtataaaa agttataaaa taatcttggc ggaaccattc aaaacagcat    120
agcaagttaa aataaggcta gtcggttatc aacttgaaaa agtggcaccg agtcggtgct    180
tttttt                186

<210> SEQ ID NO 337
<211> LENGTH: 95
<212> TYPE: DNA

```

-continued

<213> ORGANISM: Artificial Sequence
<220> FEATURE:
<223> OTHER INFORMATION: Description of Artificial Sequence: Synthetic
oligonucleotide

<400> SEQUENCE: 337

gggttttaga gctatgctgt tttgaatggt cccaaaacgg gtcttcgaga agacgtttta 60

gagctatgct gttttgaatg gtcccaaac ttttt 95

<210> SEQ ID NO 338
<211> LENGTH: 36
<212> TYPE: DNA
<213> ORGANISM: Artificial Sequence
<220> FEATURE:
<223> OTHER INFORMATION: Description of Artificial Sequence: Synthetic
oligonucleotide
<220> FEATURE:
<221> NAME/KEY: modified_base
<222> LOCATION: (5)..(34)
<223> OTHER INFORMATION: a, c, t, g, unknown or other

<400> SEQUENCE: 338

aaacnnnnnn nnnnnnnnnn nnnnnnnnnn nnnngt 36

<210> SEQ ID NO 339
<211> LENGTH: 36
<212> TYPE: DNA
<213> ORGANISM: Artificial Sequence
<220> FEATURE:
<223> OTHER INFORMATION: Description of Artificial Sequence: Synthetic
oligonucleotide
<220> FEATURE:
<221> NAME/KEY: modified_base
<222> LOCATION: (7)..(36)
<223> OTHER INFORMATION: a, c, t, g, unknown or other

<400> SEQUENCE: 339

taaaacnnnn nnnnnnnnnn nnnnnnnnnn nnnnnn 36

<210> SEQ ID NO 340
<211> LENGTH: 84
<212> TYPE: DNA
<213> ORGANISM: Artificial Sequence
<220> FEATURE:
<223> OTHER INFORMATION: Description of Artificial Sequence: Synthetic
oligonucleotide

<400> SEQUENCE: 340

gtggaaagga cgaaacaccg ggtcttcgag aagacctggt ttagagctag aaatagcaag 60

ttaaataag gctagtccgt tttt 84

<210> SEQ ID NO 341
<211> LENGTH: 24
<212> TYPE: DNA
<213> ORGANISM: Artificial Sequence
<220> FEATURE:
<223> OTHER INFORMATION: Description of Artificial Sequence: Synthetic
oligonucleotide
<220> FEATURE:
<221> NAME/KEY: modified_base
<222> LOCATION: (6)..(24)
<223> OTHER INFORMATION: a, c, t, g, unknown or other

<400> SEQUENCE: 341

caccgnnnnn nnnnnnnnnn nnnn 24

-continued

<210> SEQ ID NO 342
<211> LENGTH: 24
<212> TYPE: DNA
<213> ORGANISM: Artificial Sequence
<220> FEATURE:
<223> OTHER INFORMATION: Description of Artificial Sequence: Synthetic
oligonucleotide
<220> FEATURE:
<221> NAME/KEY: modified_base
<222> LOCATION: (5)..(23)
<223> OTHER INFORMATION: a, c, t, g, unknown or other

<400> SEQUENCE: 342

aaacnnnnnn nnnnnnnnnn nnnnc 24

<210> SEQ ID NO 343
<211> LENGTH: 88
<212> TYPE: DNA
<213> ORGANISM: Artificial Sequence
<220> FEATURE:
<223> OTHER INFORMATION: Description of Artificial Sequence: Synthetic
oligonucleotide

<400> SEQUENCE: 343

gttttagagc tatgctgttt tgaatgggcc caaaactgag accaaaggctc tcgttttaga 60
gctatgctgt tttgaatggt cccaaaaac 88

<210> SEQ ID NO 344
<211> LENGTH: 35
<212> TYPE: DNA
<213> ORGANISM: Artificial Sequence
<220> FEATURE:
<223> OTHER INFORMATION: Description of Artificial Sequence: Synthetic
oligonucleotide

<400> SEQUENCE: 344

aaacggaagg gcctgagtc gagcagaaga agaag 35

<210> SEQ ID NO 345
<211> LENGTH: 35
<212> TYPE: DNA
<213> ORGANISM: Artificial Sequence
<220> FEATURE:
<223> OTHER INFORMATION: Description of Artificial Sequence: Synthetic
oligonucleotide

<400> SEQUENCE: 345

aaaacttctt cttctgctcg gactcaggcc cttcc 35

<210> SEQ ID NO 346
<211> LENGTH: 46
<212> TYPE: RNA
<213> ORGANISM: Artificial Sequence
<220> FEATURE:
<223> OTHER INFORMATION: Description of Artificial Sequence: Synthetic
oligonucleotide
<220> FEATURE:
<221> NAME/KEY: modified_base
<222> LOCATION: (1)..(19)
<223> OTHER INFORMATION: a, c, u, g, unknown or other

<400> SEQUENCE: 346

nnnnnnnnnn nnnnnnnnng uuauuguacu cucaagauuu auuuuu 46

-continued

<210> SEQ ID NO 347
 <211> LENGTH: 91
 <212> TYPE: RNA
 <213> ORGANISM: Artificial Sequence
 <220> FEATURE:
 <223> OTHER INFORMATION: Description of Artificial Sequence: Synthetic
 oligonucleotide

<400> SEQUENCE: 347

guuacuuaaa ucuugcagaa gcuacaaaga uaaggcuuca ugccgaaauc aacaccugcu	60
cauuuuuagg caggguuuu ucguuuuuu a	91

<210> SEQ ID NO 348
 <211> LENGTH: 70
 <212> TYPE: DNA
 <213> ORGANISM: Homo sapiens

<400> SEQUENCE: 348

ttttctagtg ctgagtttct gtgactcctc tacattctac ttctctgtgt ttctgtatac	60
tacctcctcc	70

<210> SEQ ID NO 349
 <211> LENGTH: 122
 <212> TYPE: DNA
 <213> ORGANISM: Homo sapiens

<400> SEQUENCE: 349

ggaggaaggg cctgagtcgc agcagaagaa gaagggtccc catcacatca accggtggcg	60
cattgccacg aagcaggcca atggggagga catcgatgtc acctccaatg actaggggtgg	120
gc	122

<210> SEQ ID NO 350
 <211> LENGTH: 48
 <212> TYPE: RNA
 <213> ORGANISM: Artificial Sequence
 <220> FEATURE:
 <223> OTHER INFORMATION: Description of Artificial Sequence: Synthetic
 oligonucleotide
 <220> FEATURE:
 <221> NAME/KEY: modified_base
 <222> LOCATION: (3)..(32)
 <223> OTHER INFORMATION: a, c, u, g, unknown or other

<400> SEQUENCE: 350

acnnnnnnnn nnnnnnnnnn nnnnnnnnnn nnguuiuaga gcuaugcu	48
--	----

<210> SEQ ID NO 351
 <211> LENGTH: 67
 <212> TYPE: DNA
 <213> ORGANISM: Artificial Sequence
 <220> FEATURE:
 <223> OTHER INFORMATION: Description of Artificial Sequence: Synthetic
 oligonucleotide
 <220> FEATURE:
 <223> OTHER INFORMATION: Description of Combined DNA/RNA Molecule:
 Synthetic oligonucleotide

<400> SEQUENCE: 351

agcauagcaa guuuuuuuuu ggctaguccg uuaucaacu gaaaaagugg caccgagucg	60
gugcuuu	67

-continued

<210> SEQ ID NO 352
 <211> LENGTH: 62
 <212> TYPE: RNA
 <213> ORGANISM: Artificial Sequence
 <220> FEATURE:
 <223> OTHER INFORMATION: Description of Artificial Sequence: Synthetic
 oligonucleotide
 <220> FEATURE:
 <221> NAME/KEY: modified_base
 <222> LOCATION: (1)..(20)
 <223> OTHER INFORMATION: a, c, u, g, unknown or other

<400> SEQUENCE: 352
 nnnnnnnnnn nnnnnnnnnn guuuuagagc uagaaauagc aaguuaaaau aaggcuaguc 60
 cg 62

<210> SEQ ID NO 353
 <211> LENGTH: 73
 <212> TYPE: DNA
 <213> ORGANISM: Artificial Sequence
 <220> FEATURE:
 <223> OTHER INFORMATION: Description of Artificial Sequence: Synthetic
 oligonucleotide

<400> SEQUENCE: 353
 tgaatggtcc caaacggaa gggcctgagt ccgagcagaa gaagaagttt tagagctatg 60
 ctgttttgaa tgg 73

<210> SEQ ID NO 354
 <211> LENGTH: 69
 <212> TYPE: DNA
 <213> ORGANISM: Homo sapiens

<400> SEQUENCE: 354
 ctggtcttcc acctctctgc cctgaacacc caatctcggc ccctctcggc acctcctgc 60
 atttctggtt 69

<210> SEQ ID NO 355
 <211> LENGTH: 138
 <212> TYPE: DNA
 <213> ORGANISM: Mus musculus

<400> SEQUENCE: 355
 acccaagcac tgagtgccat tagctaaatg catagggtag caccacaggg tgccaggggc 60
 ctttcccaaa gttcccagcc ccttctccaa ccttctcggg cccagagget ttcccatgtg 120
 tgtggctgga ccctttga 138

<210> SEQ ID NO 356
 <211> LENGTH: 20
 <212> TYPE: DNA
 <213> ORGANISM: Artificial Sequence
 <220> FEATURE:
 <223> OTHER INFORMATION: Description of Artificial Sequence: Synthetic
 primer

<400> SEQUENCE: 356
 gtgctttgca gaggcctacc 20

<210> SEQ ID NO 357
 <211> LENGTH: 20

-continued

<212> TYPE: DNA
<213> ORGANISM: Artificial Sequence
<220> FEATURE:
<223> OTHER INFORMATION: Description of Artificial Sequence: Synthetic
primer

<400> SEQUENCE: 357

cctggagcgc atgcagtagt 20

<210> SEQ ID NO 358
<211> LENGTH: 22
<212> TYPE: DNA
<213> ORGANISM: Artificial Sequence
<220> FEATURE:
<223> OTHER INFORMATION: Description of Artificial Sequence: Synthetic
primer

<400> SEQUENCE: 358

accttctgtg tttccacat tc 22

<210> SEQ ID NO 359
<211> LENGTH: 20
<212> TYPE: DNA
<213> ORGANISM: Artificial Sequence
<220> FEATURE:
<223> OTHER INFORMATION: Description of Artificial Sequence: Synthetic
primer

<400> SEQUENCE: 359

ttggggagtg cacagacttc 20

<210> SEQ ID NO 360
<211> LENGTH: 20
<212> TYPE: DNA
<213> ORGANISM: Artificial Sequence
<220> FEATURE:
<223> OTHER INFORMATION: Description of Artificial Sequence: Synthetic
primer

<400> SEQUENCE: 360

ggctccctgg gttcaaagta 20

<210> SEQ ID NO 361
<211> LENGTH: 21
<212> TYPE: DNA
<213> ORGANISM: Artificial Sequence
<220> FEATURE:
<223> OTHER INFORMATION: Description of Artificial Sequence: Synthetic
primer

<400> SEQUENCE: 361

agaggggtct g gatgctgta a 21

<210> SEQ ID NO 362
<211> LENGTH: 30
<212> TYPE: DNA
<213> ORGANISM: Artificial Sequence
<220> FEATURE:
<223> OTHER INFORMATION: Description of Artificial Sequence: Synthetic
probe

<400> SEQUENCE: 362

tagctctaaa acttcttctt ctgctcggac 30

-continued

<210> SEQ ID NO 363
 <211> LENGTH: 30
 <212> TYPE: DNA
 <213> ORGANISM: Artificial Sequence
 <220> FEATURE:
 <223> OTHER INFORMATION: Description of Artificial Sequence: Synthetic
 probe

 <400> SEQUENCE: 363

 ctagccttat ttttaacttgc tatgctgttt 30

<210> SEQ ID NO 364
 <211> LENGTH: 99
 <212> TYPE: RNA
 <213> ORGANISM: Artificial Sequence
 <220> FEATURE:
 <223> OTHER INFORMATION: Description of Artificial Sequence: Synthetic
 oligonucleotide
 <220> FEATURE:
 <221> NAME/KEY: modified_base
 <222> LOCATION: (1)..(20)
 <223> OTHER INFORMATION: a, c, u, g, unknown or other

 <400> SEQUENCE: 364

 nnnnnnnnnn nnnnnnnnnn guuuuagagc uagaaaagc aaguuaaaau aaggcuaguc 60
 cguaaucaac uugaaaaagu ggcaccgagu cggugcuuu 99

<210> SEQ ID NO 365
 <211> LENGTH: 12
 <212> TYPE: DNA
 <213> ORGANISM: Homo sapiens

 <400> SEQUENCE: 365

 tagcgggtaa gc 12

<210> SEQ ID NO 366
 <211> LENGTH: 12
 <212> TYPE: DNA
 <213> ORGANISM: Homo sapiens

 <400> SEQUENCE: 366

 tcggtgacat gt 12

<210> SEQ ID NO 367
 <211> LENGTH: 12
 <212> TYPE: DNA
 <213> ORGANISM: Homo sapiens

 <400> SEQUENCE: 367

 actccccgta gg 12

<210> SEQ ID NO 368
 <211> LENGTH: 12
 <212> TYPE: DNA
 <213> ORGANISM: Homo sapiens

 <400> SEQUENCE: 368

 actgcgtgtt aa 12

<210> SEQ ID NO 369
 <211> LENGTH: 12
 <212> TYPE: DNA
 <213> ORGANISM: Homo sapiens

-continued

<400> SEQUENCE: 369
acgtcgcctg at 12

<210> SEQ ID NO 370
<211> LENGTH: 12
<212> TYPE: DNA
<213> ORGANISM: Homo sapiens
<400> SEQUENCE: 370
taggtcgacc ag 12

<210> SEQ ID NO 371
<211> LENGTH: 12
<212> TYPE: DNA
<213> ORGANISM: Homo sapiens
<400> SEQUENCE: 371
ggcgttaatg at 12

<210> SEQ ID NO 372
<211> LENGTH: 12
<212> TYPE: DNA
<213> ORGANISM: Homo sapiens
<400> SEQUENCE: 372
tgtcgcattg ta 12

<210> SEQ ID NO 373
<211> LENGTH: 12
<212> TYPE: DNA
<213> ORGANISM: Homo sapiens
<400> SEQUENCE: 373
atggaacgc at 12

<210> SEQ ID NO 374
<211> LENGTH: 12
<212> TYPE: DNA
<213> ORGANISM: Homo sapiens
<400> SEQUENCE: 374
gccgaattcc tc 12

<210> SEQ ID NO 375
<211> LENGTH: 12
<212> TYPE: DNA
<213> ORGANISM: Homo sapiens
<400> SEQUENCE: 375
gcatggtacg ga 12

<210> SEQ ID NO 376
<211> LENGTH: 12
<212> TYPE: DNA
<213> ORGANISM: Homo sapiens
<400> SEQUENCE: 376
cggctactctt ac 12

-continued

<210> SEQ ID NO 377
<211> LENGTH: 12
<212> TYPE: DNA
<213> ORGANISM: Homo sapiens

<400> SEQUENCE: 377

gectgtgccc ta 12

<210> SEQ ID NO 378
<211> LENGTH: 12
<212> TYPE: DNA
<213> ORGANISM: Homo sapiens

<400> SEQUENCE: 378

tacggtaagt cg 12

<210> SEQ ID NO 379
<211> LENGTH: 12
<212> TYPE: DNA
<213> ORGANISM: Homo sapiens

<400> SEQUENCE: 379

cacgaaatta cc 12

<210> SEQ ID NO 380
<211> LENGTH: 12
<212> TYPE: DNA
<213> ORGANISM: Homo sapiens

<400> SEQUENCE: 380

aaccaagata cg 12

<210> SEQ ID NO 381
<211> LENGTH: 12
<212> TYPE: DNA
<213> ORGANISM: Homo sapiens

<400> SEQUENCE: 381

gagtcgat ac gc 12

<210> SEQ ID NO 382
<211> LENGTH: 12
<212> TYPE: DNA
<213> ORGANISM: Homo sapiens

<400> SEQUENCE: 382

gtctcacgat cg 12

<210> SEQ ID NO 383
<211> LENGTH: 12
<212> TYPE: DNA
<213> ORGANISM: Homo sapiens

<400> SEQUENCE: 383

tcgctgggtg ca 12

<210> SEQ ID NO 384
<211> LENGTH: 12
<212> TYPE: DNA
<213> ORGANISM: Homo sapiens

<400> SEQUENCE: 384

-continued

actccgtagt ga 12

<210> SEQ ID NO 385
<211> LENGTH: 12
<212> TYPE: DNA
<213> ORGANISM: Homo sapiens

<400> SEQUENCE: 385

caggacgtcc gt 12

<210> SEQ ID NO 386
<211> LENGTH: 12
<212> TYPE: DNA
<213> ORGANISM: Homo sapiens

<400> SEQUENCE: 386

tcgtatccct ac 12

<210> SEQ ID NO 387
<211> LENGTH: 12
<212> TYPE: DNA
<213> ORGANISM: Homo sapiens

<400> SEQUENCE: 387

tttcaaggcc gg 12

<210> SEQ ID NO 388
<211> LENGTH: 12
<212> TYPE: DNA
<213> ORGANISM: Homo sapiens

<400> SEQUENCE: 388

cgccggtgga at 12

<210> SEQ ID NO 389
<211> LENGTH: 12
<212> TYPE: DNA
<213> ORGANISM: Homo sapiens

<400> SEQUENCE: 389

gaaccctcc ta 12

<210> SEQ ID NO 390
<211> LENGTH: 12
<212> TYPE: DNA
<213> ORGANISM: Homo sapiens

<400> SEQUENCE: 390

gattcatcag cg 12

<210> SEQ ID NO 391
<211> LENGTH: 12
<212> TYPE: DNA
<213> ORGANISM: Homo sapiens

<400> SEQUENCE: 391

acaccgtct tc 12

<210> SEQ ID NO 392
<211> LENGTH: 12

-continued

<212> TYPE: DNA
<213> ORGANISM: Homo sapiens

<400> SEQUENCE: 392

atcgtgccct aa 12

<210> SEQ ID NO 393
<211> LENGTH: 12
<212> TYPE: DNA
<213> ORGANISM: Homo sapiens

<400> SEQUENCE: 393

gcgtcaatgt tc 12

<210> SEQ ID NO 394
<211> LENGTH: 12
<212> TYPE: DNA
<213> ORGANISM: Homo sapiens

<400> SEQUENCE: 394

ctccgtatct cg 12

<210> SEQ ID NO 395
<211> LENGTH: 12
<212> TYPE: DNA
<213> ORGANISM: Homo sapiens

<400> SEQUENCE: 395

cggattcctt cg 12

<210> SEQ ID NO 396
<211> LENGTH: 12
<212> TYPE: DNA
<213> ORGANISM: Homo sapiens

<400> SEQUENCE: 396

tgcgcctcca gt 12

<210> SEQ ID NO 397
<211> LENGTH: 12
<212> TYPE: DNA
<213> ORGANISM: Homo sapiens

<400> SEQUENCE: 397

taacgtcgga gc 12

<210> SEQ ID NO 398
<211> LENGTH: 12
<212> TYPE: DNA
<213> ORGANISM: Homo sapiens

<400> SEQUENCE: 398

aaggtcgccc at 12

<210> SEQ ID NO 399
<211> LENGTH: 12
<212> TYPE: DNA
<213> ORGANISM: Homo sapiens

<400> SEQUENCE: 399

gtcggggact at 12

-continued

<210> SEQ ID NO 400
<211> LENGTH: 12
<212> TYPE: DNA
<213> ORGANISM: Homo sapiens

<400> SEQUENCE: 400

ttcgagcgat tt 12

<210> SEQ ID NO 401
<211> LENGTH: 12
<212> TYPE: DNA
<213> ORGANISM: Homo sapiens

<400> SEQUENCE: 401

tgagtcgtcg ag 12

<210> SEQ ID NO 402
<211> LENGTH: 12
<212> TYPE: DNA
<213> ORGANISM: Homo sapiens

<400> SEQUENCE: 402

tttacgcaga gg 12

<210> SEQ ID NO 403
<211> LENGTH: 12
<212> TYPE: DNA
<213> ORGANISM: Homo sapiens

<400> SEQUENCE: 403

aggaagtatc gc 12

<210> SEQ ID NO 404
<211> LENGTH: 12
<212> TYPE: DNA
<213> ORGANISM: Homo sapiens

<400> SEQUENCE: 404

actcgatacc at 12

<210> SEQ ID NO 405
<211> LENGTH: 12
<212> TYPE: DNA
<213> ORGANISM: Homo sapiens

<400> SEQUENCE: 405

cgctacatag ca 12

<210> SEQ ID NO 406
<211> LENGTH: 12
<212> TYPE: DNA
<213> ORGANISM: Homo sapiens

<400> SEQUENCE: 406

ttcataaccg gc 12

<210> SEQ ID NO 407
<211> LENGTH: 12
<212> TYPE: DNA
<213> ORGANISM: Homo sapiens

-continued

<400> SEQUENCE: 407
ccaaacggtt aa 12

<210> SEQ ID NO 408
<211> LENGTH: 12
<212> TYPE: DNA
<213> ORGANISM: Homo sapiens

<400> SEQUENCE: 408
cgattccttc gt 12

<210> SEQ ID NO 409
<211> LENGTH: 12
<212> TYPE: DNA
<213> ORGANISM: Homo sapiens

<400> SEQUENCE: 409
cgtcatgaat aa 12

<210> SEQ ID NO 410
<211> LENGTH: 12
<212> TYPE: DNA
<213> ORGANISM: Homo sapiens

<400> SEQUENCE: 410
agtggcgatg ac 12

<210> SEQ ID NO 411
<211> LENGTH: 12
<212> TYPE: DNA
<213> ORGANISM: Homo sapiens

<400> SEQUENCE: 411
cccctacggc ac 12

<210> SEQ ID NO 412
<211> LENGTH: 12
<212> TYPE: DNA
<213> ORGANISM: Homo sapiens

<400> SEQUENCE: 412
gccaacccgc ac 12

<210> SEQ ID NO 413
<211> LENGTH: 12
<212> TYPE: DNA
<213> ORGANISM: Homo sapiens

<400> SEQUENCE: 413
tgggacaccg gt 12

<210> SEQ ID NO 414
<211> LENGTH: 12
<212> TYPE: DNA
<213> ORGANISM: Homo sapiens

<400> SEQUENCE: 414
ttgactgcgg cg 12

-continued

<210> SEQ ID NO 415
<211> LENGTH: 12
<212> TYPE: DNA
<213> ORGANISM: Homo sapiens

<400> SEQUENCE: 415

actatgcgta gg 12

<210> SEQ ID NO 416
<211> LENGTH: 12
<212> TYPE: DNA
<213> ORGANISM: Homo sapiens

<400> SEQUENCE: 416

tcacccaaag cg 12

<210> SEQ ID NO 417
<211> LENGTH: 12
<212> TYPE: DNA
<213> ORGANISM: Homo sapiens

<400> SEQUENCE: 417

gcaggacgtc cg 12

<210> SEQ ID NO 418
<211> LENGTH: 12
<212> TYPE: DNA
<213> ORGANISM: Homo sapiens

<400> SEQUENCE: 418

acaccgaaaa cg 12

<210> SEQ ID NO 419
<211> LENGTH: 12
<212> TYPE: DNA
<213> ORGANISM: Homo sapiens

<400> SEQUENCE: 419

cgggtattg ag 12

<210> SEQ ID NO 420
<211> LENGTH: 12
<212> TYPE: DNA
<213> ORGANISM: Homo sapiens

<400> SEQUENCE: 420

cacgaggtat gc 12

<210> SEQ ID NO 421
<211> LENGTH: 12
<212> TYPE: DNA
<213> ORGANISM: Homo sapiens

<400> SEQUENCE: 421

taaagcgacc cg 12

<210> SEQ ID NO 422
<211> LENGTH: 12
<212> TYPE: DNA
<213> ORGANISM: Homo sapiens

<400> SEQUENCE: 422

-continued

cttagtcggc ca 12

<210> SEQ ID NO 423
<211> LENGTH: 12
<212> TYPE: DNA
<213> ORGANISM: Homo sapiens

<400> SEQUENCE: 423

cgaaaacgtg gc 12

<210> SEQ ID NO 424
<211> LENGTH: 12
<212> TYPE: DNA
<213> ORGANISM: Homo sapiens

<400> SEQUENCE: 424

cgtgccctga ac 12

<210> SEQ ID NO 425
<211> LENGTH: 12
<212> TYPE: DNA
<213> ORGANISM: Homo sapiens

<400> SEQUENCE: 425

tttaccatcg aa 12

<210> SEQ ID NO 426
<211> LENGTH: 12
<212> TYPE: DNA
<213> ORGANISM: Homo sapiens

<400> SEQUENCE: 426

egtagccatg tt 12

<210> SEQ ID NO 427
<211> LENGTH: 12
<212> TYPE: DNA
<213> ORGANISM: Homo sapiens

<400> SEQUENCE: 427

cccaaacggt ta 12

<210> SEQ ID NO 428
<211> LENGTH: 12
<212> TYPE: DNA
<213> ORGANISM: Homo sapiens

<400> SEQUENCE: 428

gcggttatcag aa 12

<210> SEQ ID NO 429
<211> LENGTH: 12
<212> TYPE: DNA
<213> ORGANISM: Homo sapiens

<400> SEQUENCE: 429

tcgatggtaa ac 12

<210> SEQ ID NO 430
<211> LENGTH: 12

-continued

<212> TYPE: DNA
<213> ORGANISM: Homo sapiens

<400> SEQUENCE: 430

cgactttttg ca 12

<210> SEQ ID NO 431
<211> LENGTH: 12
<212> TYPE: DNA
<213> ORGANISM: Homo sapiens

<400> SEQUENCE: 431

tcgacgactc ac 12

<210> SEQ ID NO 432
<211> LENGTH: 12
<212> TYPE: DNA
<213> ORGANISM: Homo sapiens

<400> SEQUENCE: 432

acgcgtcaga ta 12

<210> SEQ ID NO 433
<211> LENGTH: 12
<212> TYPE: DNA
<213> ORGANISM: Homo sapiens

<400> SEQUENCE: 433

cgtagcggcac ag 12

<210> SEQ ID NO 434
<211> LENGTH: 12
<212> TYPE: DNA
<213> ORGANISM: Homo sapiens

<400> SEQUENCE: 434

ctatgccgtg ca 12

<210> SEQ ID NO 435
<211> LENGTH: 12
<212> TYPE: DNA
<213> ORGANISM: Homo sapiens

<400> SEQUENCE: 435

cgcgtcagat at 12

<210> SEQ ID NO 436
<211> LENGTH: 12
<212> TYPE: DNA
<213> ORGANISM: Homo sapiens

<400> SEQUENCE: 436

aagatcggta gc 12

<210> SEQ ID NO 437
<211> LENGTH: 12
<212> TYPE: DNA
<213> ORGANISM: Homo sapiens

<400> SEQUENCE: 437

cttcgcaagg ag 12

-continued

<210> SEQ ID NO 438
<211> LENGTH: 12
<212> TYPE: DNA
<213> ORGANISM: Homo sapiens

<400> SEQUENCE: 438

gtcgtggact ac 12

<210> SEQ ID NO 439
<211> LENGTH: 12
<212> TYPE: DNA
<213> ORGANISM: Homo sapiens

<400> SEQUENCE: 439

ggtcgtcatc aa 12

<210> SEQ ID NO 440
<211> LENGTH: 12
<212> TYPE: DNA
<213> ORGANISM: Homo sapiens

<400> SEQUENCE: 440

gttaacagcg tg 12

<210> SEQ ID NO 441
<211> LENGTH: 12
<212> TYPE: DNA
<213> ORGANISM: Homo sapiens

<400> SEQUENCE: 441

tagctaaccg tt 12

<210> SEQ ID NO 442
<211> LENGTH: 12
<212> TYPE: DNA
<213> ORGANISM: Homo sapiens

<400> SEQUENCE: 442

agtaaaggcg ct 12

<210> SEQ ID NO 443
<211> LENGTH: 12
<212> TYPE: DNA
<213> ORGANISM: Homo sapiens

<400> SEQUENCE: 443

ggtaatttcg tg 12

<210> SEQ ID NO 444
<211> LENGTH: 69
<212> TYPE: RNA
<213> ORGANISM: Artificial Sequence
<220> FEATURE:
<223> OTHER INFORMATION: Description of Artificial Sequence: Synthetic
oligonucleotide

<400> SEQUENCE: 444

gucaccucca augacuaggg guuuuagagc uagaaauagc aaguuaaaau aaggcuaguc 60

cguuuuuuu 69

-continued

<210> SEQ ID NO 445
<211> LENGTH: 69
<212> TYPE: RNA
<213> ORGANISM: Artificial Sequence
<220> FEATURE:
<223> OTHER INFORMATION: Description of Artificial Sequence: Synthetic
oligonucleotide

<400> SEQUENCE: 445

gacaucgaug uccuccccau guuuuagagc uagaaaagc aaguuaaaau aaggcuaguc 60

cguuuuuuu 69

<210> SEQ ID NO 446
<211> LENGTH: 69
<212> TYPE: RNA
<213> ORGANISM: Artificial Sequence
<220> FEATURE:
<223> OTHER INFORMATION: Description of Artificial Sequence: Synthetic
oligonucleotide

<400> SEQUENCE: 446

gaguccgagc agaagaagaa guuuuagagc uagaaaagc aaguuaaaau aaggcuaguc 60

cguuuuuuu 69

<210> SEQ ID NO 447
<211> LENGTH: 69
<212> TYPE: RNA
<213> ORGANISM: Artificial Sequence
<220> FEATURE:
<223> OTHER INFORMATION: Description of Artificial Sequence: Synthetic
oligonucleotide

<400> SEQUENCE: 447

ggggccgaga uuggguguuc guuuuagagc uagaaaagc aaguuaaaau aaggcuaguc 60

cguuuuuuu 69

<210> SEQ ID NO 448
<211> LENGTH: 69
<212> TYPE: RNA
<213> ORGANISM: Artificial Sequence
<220> FEATURE:
<223> OTHER INFORMATION: Description of Artificial Sequence: Synthetic
oligonucleotide

<400> SEQUENCE: 448

guggcgagag gggccgagau guuuuagagc uagaaaagc aaguuaaaau aaggcuaguc 60

cguuuuuuu 69

<210> SEQ ID NO 449
<211> LENGTH: 76
<212> TYPE: RNA
<213> ORGANISM: Artificial Sequence
<220> FEATURE:
<223> OTHER INFORMATION: Description of Artificial Sequence: Synthetic
oligonucleotide

<400> SEQUENCE: 449

gucaccucca augacuaggg guuuuagagc uagaaaagc aaguuaaaau aaggcuaguc 60

cguuaucauu uuuuuu 76

-continued

<210> SEQ ID NO 450
<211> LENGTH: 76
<212> TYPE: RNA
<213> ORGANISM: Artificial Sequence
<220> FEATURE:
<223> OTHER INFORMATION: Description of Artificial Sequence: Synthetic
oligonucleotide

<400> SEQUENCE: 450

gacaucgaug uccuccccau guuuuagagc uagaaaauagc aaguuaaaa aagggcuaguc 60
cguaucacau uuuuuu 76

<210> SEQ ID NO 451
<211> LENGTH: 76
<212> TYPE: RNA
<213> ORGANISM: Artificial Sequence
<220> FEATURE:
<223> OTHER INFORMATION: Description of Artificial Sequence: Synthetic
oligonucleotide

<400> SEQUENCE: 451

gaguccgagc agaagaagaa guuuuagagc uagaaaauagc aaguuaaaa aagggcuaguc 60
cguaucacau uuuuuu 76

<210> SEQ ID NO 452
<211> LENGTH: 76
<212> TYPE: RNA
<213> ORGANISM: Artificial Sequence
<220> FEATURE:
<223> OTHER INFORMATION: Description of Artificial Sequence: Synthetic
oligonucleotide

<400> SEQUENCE: 452

ggggccgaga uggggguguc guuuuagagc uagaaaauagc aaguuaaaa aagggcuaguc 60
cguaucacau uuuuuu 76

<210> SEQ ID NO 453
<211> LENGTH: 76
<212> TYPE: RNA
<213> ORGANISM: Artificial Sequence
<220> FEATURE:
<223> OTHER INFORMATION: Description of Artificial Sequence: Synthetic
oligonucleotide

<400> SEQUENCE: 453

guggccgagag gggccgagau guuuuagagc uagaaaauagc aaguuaaaa aagggcuaguc 60
cguaucacau uuuuuu 76

<210> SEQ ID NO 454
<211> LENGTH: 88
<212> TYPE: RNA
<213> ORGANISM: Artificial Sequence
<220> FEATURE:
<223> OTHER INFORMATION: Description of Artificial Sequence: Synthetic
oligonucleotide

<400> SEQUENCE: 454

gucaccucca augacuaggg guuuuagagc uagaaaauagc aaguuaaaa aagggcuaguc 60
cguaucacac ugaaaaagu guuuuuuu 88

<210> SEQ ID NO 455

-continued

<211> LENGTH: 88
<212> TYPE: RNA
<213> ORGANISM: Artificial Sequence
<220> FEATURE:
<223> OTHER INFORMATION: Description of Artificial Sequence: Synthetic
oligonucleotide

<400> SEQUENCE: 455

gacaucgaug uccuccccau guuuuagagc uagaaaagc aaguuaaaau aaggcuaguc 60
cguaaucaac uugaaaaagu guuuuuuu 88

<210> SEQ ID NO 456
<211> LENGTH: 88
<212> TYPE: RNA
<213> ORGANISM: Artificial Sequence
<220> FEATURE:
<223> OTHER INFORMATION: Description of Artificial Sequence: Synthetic
oligonucleotide

<400> SEQUENCE: 456

gaguccgagc agaagaagaa guuuuagagc uagaaaagc aaguuaaaau aaggcuaguc 60
cguaaucaac uugaaaaagu guuuuuuu 88

<210> SEQ ID NO 457
<211> LENGTH: 88
<212> TYPE: RNA
<213> ORGANISM: Artificial Sequence
<220> FEATURE:
<223> OTHER INFORMATION: Description of Artificial Sequence: Synthetic
oligonucleotide

<400> SEQUENCE: 457

ggggccgaga uuggguguuc guuuuagagc uagaaaagc aaguuaaaau aaggcuaguc 60
cguaaucaac uugaaaaagu guuuuuuu 88

<210> SEQ ID NO 458
<211> LENGTH: 88
<212> TYPE: RNA
<213> ORGANISM: Artificial Sequence
<220> FEATURE:
<223> OTHER INFORMATION: Description of Artificial Sequence: Synthetic
oligonucleotide

<400> SEQUENCE: 458

guggcgagag gggccgagau guuuuagagc uagaaaagc aaguuaaaau aaggcuaguc 60
cguaaucaac uugaaaaagu guuuuuuu 88

<210> SEQ ID NO 459
<211> LENGTH: 103
<212> TYPE: RNA
<213> ORGANISM: Artificial Sequence
<220> FEATURE:
<223> OTHER INFORMATION: Description of Artificial Sequence: Synthetic
oligonucleotide

<400> SEQUENCE: 459

gucaccucca augacuaggg guuuuagagc uagaaaagc aaguuaaaau aaggcuaguc 60
cguaaucaac uugaaaaagu ggcaccgagu cggugcuuuu uuu 103

<210> SEQ ID NO 460
<211> LENGTH: 103

-continued

<212> TYPE: RNA
<213> ORGANISM: Artificial Sequence
<220> FEATURE:
<223> OTHER INFORMATION: Description of Artificial Sequence: Synthetic
oligonucleotide

<400> SEQUENCE: 460

gacaucgaug uccuccccau guuuuagagc uagaaaauagc aaguuaaaaau aaggcuaguc 60

cguuaucaac uugaaaaaagu ggcaccgagu cggugcuuuu uuu 103

<210> SEQ ID NO 461
<211> LENGTH: 103
<212> TYPE: RNA
<213> ORGANISM: Artificial Sequence
<220> FEATURE:
<223> OTHER INFORMATION: Description of Artificial Sequence: Synthetic
oligonucleotide

<400> SEQUENCE: 461

gaguccgagc agaagaagaa guuuuagagc uagaaaauagc aaguuaaaaau aaggcuaguc 60

cguuaucaac uugaaaaaagu ggcaccgagu cggugcuuuu uuu 103

<210> SEQ ID NO 462
<211> LENGTH: 103
<212> TYPE: RNA
<213> ORGANISM: Artificial Sequence
<220> FEATURE:
<223> OTHER INFORMATION: Description of Artificial Sequence: Synthetic
oligonucleotide

<400> SEQUENCE: 462

ggggccgaga uuggguguuc guuuuagagc uagaaaauagc aaguuaaaaau aaggcuaguc 60

cguuaucaac uugaaaaaagu ggcaccgagu cggugcuuuu uuu 103

<210> SEQ ID NO 463
<211> LENGTH: 103
<212> TYPE: RNA
<213> ORGANISM: Artificial Sequence
<220> FEATURE:
<223> OTHER INFORMATION: Description of Artificial Sequence: Synthetic
oligonucleotide

<400> SEQUENCE: 463

guggcgagag gggccgagau guuuuagagc uagaaaauagc aaguuaaaaau aaggcuaguc 60

cguuaucaac uugaaaaaagu ggcaccgagu cggugcuuuu uuu 103

<210> SEQ ID NO 464
<211> LENGTH: 120
<212> TYPE: DNA
<213> ORGANISM: Artificial Sequence
<220> FEATURE:
<223> OTHER INFORMATION: Description of Artificial Sequence: Synthetic
polynucleotide

<400> SEQUENCE: 464

gtggaaggga cgaaacaccg ggtcttcgag aagacctgtt ttagagctag aaatagcaag 60

ttaaataaag gctagtccgt tatcaacttg aaaaagtggc accgagtcgg tgctttttt 120

<210> SEQ ID NO 465
<211> LENGTH: 40
<212> TYPE: DNA

-continued

<213> ORGANISM: Artificial Sequence
<220> FEATURE:
<223> OTHER INFORMATION: Description of Artificial Sequence: Synthetic
oligonucleotide

<400> SEQUENCE: 465

tcggtgcgct ggttgatttc ttcttgcgct tttttggett 40

<210> SEQ ID NO 466
<211> LENGTH: 26
<212> TYPE: RNA
<213> ORGANISM: Artificial Sequence
<220> FEATURE:
<223> OTHER INFORMATION: Description of Artificial Sequence: Synthetic
oligonucleotide

<400> SEQUENCE: 466

gauuucuucu ugcgcuuuuu guuuua 26

<210> SEQ ID NO 467
<211> LENGTH: 26
<212> TYPE: DNA
<213> ORGANISM: Artificial Sequence
<220> FEATURE:
<223> OTHER INFORMATION: Description of Artificial Sequence: Synthetic
oligonucleotide
<220> FEATURE:
<221> NAME/KEY: modified_base
<222> LOCATION: (22)..(26)
<223> OTHER INFORMATION: a, c, t, g, unknown or other

<400> SEQUENCE: 467

tgatttcttc ttgcgctttt tnnnnn 26

<210> SEQ ID NO 468
<211> LENGTH: 26
<212> TYPE: DNA
<213> ORGANISM: Artificial Sequence
<220> FEATURE:
<223> OTHER INFORMATION: Description of Artificial Sequence: Synthetic
oligonucleotide
<220> FEATURE:
<221> NAME/KEY: modified_base
<222> LOCATION: (21)..(21)
<223> OTHER INFORMATION: a, c, t, g, unknown or other

<400> SEQUENCE: 468

tgatttcttc ttgcgctttt ntggct 26

<210> SEQ ID NO 469
<211> LENGTH: 26
<212> TYPE: DNA
<213> ORGANISM: Artificial Sequence
<220> FEATURE:
<223> OTHER INFORMATION: Description of Artificial Sequence: Synthetic
oligonucleotide
<220> FEATURE:
<221> NAME/KEY: modified_base
<222> LOCATION: (2)..(2)
<223> OTHER INFORMATION: a, c, t, g, unknown or other

<400> SEQUENCE: 469

tnatttcttc ttgcgctttt ttggct 26

<210> SEQ ID NO 470
<211> LENGTH: 23

-continued

<212> TYPE: DNA
<213> ORGANISM: Artificial Sequence
<220> FEATURE:
<223> OTHER INFORMATION: Description of Artificial Sequence: Synthetic
oligonucleotide

<400> SEQUENCE: 470

gatttottct tgcgcttttt tgg 23

<210> SEQ ID NO 471
<211> LENGTH: 34
<212> TYPE: DNA
<213> ORGANISM: Artificial Sequence
<220> FEATURE:
<223> OTHER INFORMATION: Description of Artificial Sequence: Synthetic
oligonucleotide
<220> FEATURE:
<221> NAME/KEY: CDS
<222> LOCATION: (1)..(33)

<400> SEQUENCE: 471

tcc atc cgt aca acc cac aac cct gct agt gag c 34
Ser Ile Arg Thr Thr His Asn Pro Ala Ser Glu
1 5 10

<210> SEQ ID NO 472
<211> LENGTH: 11
<212> TYPE: PRT
<213> ORGANISM: Artificial Sequence
<220> FEATURE:
<223> OTHER INFORMATION: Description of Artificial Sequence: Synthetic
peptide

<400> SEQUENCE: 472

Ser Ile Arg Thr Thr His Asn Pro Ala Ser Glu
1 5 10

<210> SEQ ID NO 473
<211> LENGTH: 34
<212> TYPE: DNA
<213> ORGANISM: Artificial Sequence
<220> FEATURE:
<223> OTHER INFORMATION: Description of Artificial Sequence: Synthetic
oligonucleotide
<220> FEATURE:
<221> NAME/KEY: CDS
<222> LOCATION: (1)..(33)

<400> SEQUENCE: 473

tcc atc gca aca acc cac aac cct gct agt gag c 34
Ser Ile Ala Thr Thr His Asn Pro Ala Ser Glu
1 5 10

<210> SEQ ID NO 474
<211> LENGTH: 11
<212> TYPE: PRT
<213> ORGANISM: Artificial Sequence
<220> FEATURE:
<223> OTHER INFORMATION: Description of Artificial Sequence: Synthetic
peptide

<400> SEQUENCE: 474

Ser Ile Ala Thr Thr His Asn Pro Ala Ser Glu
1 5 10

<210> SEQ ID NO 475

-continued

```

<211> LENGTH: 34
<212> TYPE: DNA
<213> ORGANISM: Artificial Sequence
<220> FEATURE:
<223> OTHER INFORMATION: Description of Artificial Sequence: Synthetic
      oligonucleotide
<220> FEATURE:
<221> NAME/KEY: CDS
<222> LOCATION: (1)..(33)

<400> SEQUENCE: 475

tca atc cgt aca acc cac aac cct gct agt gag c          34
Ser Ile Arg Thr Thr His Asn Pro Ala Ser Glu
1             5             10

<210> SEQ ID NO 476
<211> LENGTH: 42
<212> TYPE: DNA
<213> ORGANISM: Homo sapiens
<220> FEATURE:
<221> NAME/KEY: CDS
<222> LOCATION: (1)..(36)

<400> SEQUENCE: 476

caa ttg aat tta aaa gaa acc gat acc gtt ttg gtt taagga      42
Gln Leu Asn Leu Lys Glu Thr Asp Thr Val Leu Val
1             5             10

<210> SEQ ID NO 477
<211> LENGTH: 12
<212> TYPE: PRT
<213> ORGANISM: Homo sapiens

<400> SEQUENCE: 477

Gln Leu Asn Leu Lys Glu Thr Asp Thr Val Leu Val
1             5             10

<210> SEQ ID NO 478
<211> LENGTH: 42
<212> TYPE: DNA
<213> ORGANISM: Homo sapiens
<220> FEATURE:
<221> NAME/KEY: CDS
<222> LOCATION: (1)..(42)

<400> SEQUENCE: 478

caa ttg aat tta aaa gaa acc gat acc gtt tac gaa att gga      42
Gln Leu Asn Leu Lys Glu Thr Asp Thr Val Tyr Glu Ile Gly
1             5             10

<210> SEQ ID NO 479
<211> LENGTH: 14
<212> TYPE: PRT
<213> ORGANISM: Homo sapiens

<400> SEQUENCE: 479

Gln Leu Asn Leu Lys Glu Thr Asp Thr Val Tyr Glu Ile Gly
1             5             10

<210> SEQ ID NO 480
<211> LENGTH: 34
<212> TYPE: DNA
<213> ORGANISM: Homo sapiens
<220> FEATURE:
<221> NAME/KEY: CDS
<222> LOCATION: (2)..(34)

```

-continued

<400> SEQUENCE: 480

```
t cct aaa aaa ccg aac tcc gcg ctg cgt aaa gta      34
  Pro Lys Lys Pro Asn Ser Ala Leu Arg Lys Val
    1             5             10
```

<210> SEQ ID NO 481

<211> LENGTH: 11

<212> TYPE: PRT

<213> ORGANISM: Homo sapiens

<400> SEQUENCE: 481

```
Pro Lys Lys Pro Asn Ser Ala Leu Arg Lys Val
1             5             10
```

<210> SEQ ID NO 482

<211> LENGTH: 34

<212> TYPE: DNA

<213> ORGANISM: Homo sapiens

<220> FEATURE:

<221> NAME/KEY: CDS

<222> LOCATION: (2)..(34)

<400> SEQUENCE: 482

```
t cct aca aaa ccg aac tcc gcg ctg cgt aaa gta      34
  Pro Thr Lys Pro Asn Ser Ala Leu Arg Lys Val
    1             5             10
```

<210> SEQ ID NO 483

<211> LENGTH: 11

<212> TYPE: PRT

<213> ORGANISM: Homo sapiens

<400> SEQUENCE: 483

```
Pro Thr Lys Pro Asn Ser Ala Leu Arg Lys Val
1             5             10
```

<210> SEQ ID NO 484

<211> LENGTH: 33

<212> TYPE: DNA

<213> ORGANISM: Homo sapiens

<400> SEQUENCE: 484

```
tgcgctgggtt gatttcttct tgcgcttttt tgg          33
```

<210> SEQ ID NO 485

<211> LENGTH: 33

<212> TYPE: DNA

<213> ORGANISM: Homo sapiens

<400> SEQUENCE: 485

```
tacgctgggtt gatttcttct tgcgcttttt ttg          33
```

<210> SEQ ID NO 486

<211> LENGTH: 27

<212> TYPE: DNA

<213> ORGANISM: Homo sapiens

<400> SEQUENCE: 486

```
ggagggtttt atgggaaag gccattg          27
```

<210> SEQ ID NO 487

-continued

```

<211> LENGTH: 29
<212> TYPE: DNA
<213> ORGANISM: Homo sapiens

<400> SEQUENCE: 487

gtaaaaaaga agactagaaa ttttgatac                29

<210> SEQ ID NO 488
<211> LENGTH: 46
<212> TYPE: DNA
<213> ORGANISM: Homo sapiens

<400> SEQUENCE: 488

ggagggtttt atggggaaag gcaaagaaga ctagaaattt tgatac        46

<210> SEQ ID NO 489
<211> LENGTH: 27
<212> TYPE: DNA
<213> ORGANISM: Homo sapiens

<400> SEQUENCE: 489

agggtgaagca taatgtctca aaaaata                27

<210> SEQ ID NO 490
<211> LENGTH: 29
<212> TYPE: DNA
<213> ORGANISM: Homo sapiens

<400> SEQUENCE: 490

atthttattaa tacaatcag tgaatcat                29

<210> SEQ ID NO 491
<211> LENGTH: 46
<212> TYPE: DNA
<213> ORGANISM: Homo sapiens

<400> SEQUENCE: 491

agggtgaagca taatgtctca aaattaatac aaatcagtga aatcat        46

<210> SEQ ID NO 492
<211> LENGTH: 36
<212> TYPE: DNA
<213> ORGANISM: Homo sapiens
<220> FEATURE:
<221> NAME/KEY: CDS
<222> LOCATION: (1)..(36)

<400> SEQUENCE: 492

aat tta aaa gaa acc gat acc gtt tac gaa att gga        36
Asn Leu Lys Glu Thr Asp Thr Val Tyr Glu Ile Gly
1           5           10

<210> SEQ ID NO 493
<211> LENGTH: 12
<212> TYPE: PRT
<213> ORGANISM: Homo sapiens

<400> SEQUENCE: 493

Asn Leu Lys Glu Thr Asp Thr Val Tyr Glu Ile Gly
1           5           10

<210> SEQ ID NO 494

```

-continued

<211> LENGTH: 36
<212> TYPE: DNA
<213> ORGANISM: Homo sapiens
<220> FEATURE:
<221> NAME/KEY: CDS
<222> LOCATION: (1)..(30)

<400> SEQUENCE: 494

aat tta aaa gaa acc gat acc gtt ttg gtt taagga 36
Asn Leu Lys Glu Thr Asp Thr Val Leu Val
1 5 10

<210> SEQ ID NO 495
<211> LENGTH: 10
<212> TYPE: PRT
<213> ORGANISM: Homo sapiens

<400> SEQUENCE: 495

Asn Leu Lys Glu Thr Asp Thr Val Leu Val
1 5 10

<210> SEQ ID NO 496
<211> LENGTH: 36
<212> TYPE: DNA
<213> ORGANISM: Homo sapiens
<220> FEATURE:
<221> NAME/KEY: CDS
<222> LOCATION: (1)..(36)

<400> SEQUENCE: 496

tgg gat cca aaa aaa tat ggt ggt ttt gat agt cca 36
Trp Asp Pro Lys Lys Tyr Gly Gly Phe Asp Ser Pro
1 5 10

<210> SEQ ID NO 497
<211> LENGTH: 12
<212> TYPE: PRT
<213> ORGANISM: Homo sapiens

<400> SEQUENCE: 497

Trp Asp Pro Lys Lys Tyr Gly Gly Phe Asp Ser Pro
1 5 10

<210> SEQ ID NO 498
<211> LENGTH: 36
<212> TYPE: DNA
<213> ORGANISM: Artificial Sequence
<220> FEATURE:
<223> OTHER INFORMATION: Description of Artificial Sequence: Synthetic
oligonucleotide
<220> FEATURE:
<221> NAME/KEY: CDS
<222> LOCATION: (1)..(36)

<400> SEQUENCE: 498

tgg gat cca aaa aaa tat tgt ggt ttt gat agt cca 36
Trp Asp Pro Lys Lys Tyr Cys Gly Phe Asp Ser Pro
1 5 10

<210> SEQ ID NO 499
<211> LENGTH: 12
<212> TYPE: PRT
<213> ORGANISM: Artificial Sequence
<220> FEATURE:
<223> OTHER INFORMATION: Description of Artificial Sequence: Synthetic
peptide

-continued

<400> SEQUENCE: 499

Trp Asp Pro Lys Lys Tyr Cys Gly Phe Asp Ser Pro
 1 5 10

<210> SEQ ID NO 500

<211> LENGTH: 35

<212> TYPE: DNA

<213> ORGANISM: Artificial Sequence

<220> FEATURE:

<223> OTHER INFORMATION: Description of Artificial Sequence: Synthetic oligonucleotide

<400> SEQUENCE: 500

aaactacttt acgcagcgcg gagttcggtt ttttg 35

<210> SEQ ID NO 501

<211> LENGTH: 4104

<212> TYPE: DNA

<213> ORGANISM: Homo sapiens

<220> FEATURE:

<221> NAME/KEY: CDS

<222> LOCATION: (1)..(4104)

<400> SEQUENCE: 501

atg gac aag aag tac agc atc ggc ctg gac atc ggc acc aac tct gtg 48
 Met Asp Lys Lys Tyr Ser Ile Gly Leu Asp Ile Gly Thr Asn Ser Val
 1 5 10 15

ggc tgg gcc gtg atc acc gac gag tac aag gtg ccc agc aag aaa ttc 96
 Gly Trp Ala Val Ile Thr Asp Glu Tyr Lys Val Pro Ser Lys Lys Phe
 20 25 30

aag gtg ctg ggc aac acc gac cgg cac agc atc aag aag aac ctg atc 144
 Lys Val Leu Gly Asn Thr Asp Arg His Ser Ile Lys Lys Asn Leu Ile
 35 40 45

gga gcc ctg ctg ttc gac agc ggc gaa aca gcc gag gcc acc cgg ctg 192
 Gly Ala Leu Leu Phe Asp Ser Gly Glu Thr Ala Glu Ala Thr Arg Leu
 50 55 60

aag aga acc gcc aga aga aga tac acc aga cgg aag aac cgg atc tgc 240
 Lys Arg Thr Ala Arg Arg Arg Tyr Thr Arg Arg Lys Asn Arg Ile Cys
 65 70 75 80

tat ctg caa gag atc ttc agc aac gag atg gcc aag gtg gac gac agc 288
 Tyr Leu Gln Glu Ile Phe Ser Asn Glu Met Ala Lys Val Asp Asp Ser
 85 90 95

ttc ttc cac aga ctg gaa gag tcc ttc ctg gtg gaa gag gat aag aag 336
 Phe Phe His Arg Leu Glu Glu Ser Phe Leu Val Glu Glu Asp Lys Lys
 100 105 110

cac gag cgg cac ccc atc ttc ggc aac atc gtg gac gag gtg gcc tac 384
 His Glu Arg His Pro Ile Phe Gly Asn Ile Val Asp Glu Val Ala Tyr
 115 120 125

cac gag aag tac ccc acc atc tac cac ctg aga aag aaa ctg gtg gac 432
 His Glu Lys Tyr Pro Thr Ile Tyr His Leu Arg Lys Lys Leu Val Asp
 130 135 140

agc acc gac aag gcc gac ctg cgg ctg atc tat ctg gcc ctg gcc cac 480
 Ser Thr Asp Lys Ala Asp Leu Arg Leu Ile Tyr Leu Ala Leu Ala His
 145 150 155 160

atg atc aag ttc cgg ggc cac ttc ctg atc gag ggc gac ctg aac ccc 528
 Met Ile Lys Phe Arg Gly His Phe Leu Ile Glu Gly Asp Leu Asn Pro
 165 170 175

gac aac agc gac gtg gac aag ctg ttc atc cag ctg gtg cag acc tac 576
 Asp Asn Ser Asp Val Asp Lys Leu Phe Ile Gln Leu Val Gln Thr Tyr

-continued

180			185			190										
aac	cag	ctg	ttc	gag	gaa	aac	ccc	atc	aac	gcc	agc	ggc	gtg	gac	gcc	624
Asn	Gln	Leu	Phe	Glu	Glu	Asn	Pro	Ile	Asn	Ala	Ser	Gly	Val	Asp	Ala	
	195						200						205			
aag	gcc	atc	ctg	tct	gcc	aga	ctg	agc	aag	agc	aga	cgg	ctg	gaa	aat	672
Lys	Ala	Ile	Leu	Ser	Ala	Arg	Leu	Ser	Lys	Ser	Arg	Arg	Leu	Glu	Asn	
	210						215						220			
ctg	atc	gcc	cag	ctg	ccc	ggc	gag	aag	aag	aat	ggc	ctg	ttc	ggc	aac	720
Leu	Ile	Ala	Gln	Leu	Pro	Gly	Glu	Lys	Lys	Asn	Gly	Leu	Phe	Gly	Asn	
	225						230								240	
ctg	att	gcc	ctg	agc	ctg	ggc	ctg	acc	ccc	aac	ttc	aag	agc	aac	ttc	768
Leu	Ile	Ala	Leu	Ser	Leu	Gly	Leu	Thr	Pro	Asn	Phe	Lys	Ser	Asn	Phe	
				245						250					255	
gac	ctg	gcc	gag	gat	gcc	aaa	ctg	cag	ctg	agc	aag	gac	acc	tac	gac	816
Asp	Leu	Ala	Glu	Asp	Ala	Lys	Leu	Gln	Leu	Ser	Lys	Asp	Thr	Tyr	Asp	
				260						265					270	
gac	gac	ctg	gac	aac	ctg	ctg	gcc	cag	atc	ggc	gac	cag	tac	gcc	gac	864
Asp	Asp	Leu	Asp	Asn	Leu	Leu	Ala	Gln	Ile	Gly	Asp	Gln	Tyr	Ala	Asp	
				275						280					285	
ctg	ttt	ctg	gcc	gcc	aag	aac	ctg	tcc	gac	gcc	atc	ctg	ctg	agc	gac	912
Leu	Phe	Leu	Ala	Ala	Lys	Asn	Leu	Ser	Asp	Ala	Ile	Leu	Leu	Ser	Asp	
				290						295					300	
atc	ctg	aga	gtg	aac	acc	gag	atc	acc	aag	gcc	ccc	ctg	agc	gcc	tct	960
Ile	Leu	Arg	Val	Asn	Thr	Glu	Ile	Thr	Lys	Ala	Pro	Leu	Ser	Ala	Ser	
	305						310								320	
atg	atc	aag	aga	tac	gac	gag	cac	cac	cag	gac	ctg	acc	ctg	ctg	aaa	1008
Met	Ile	Lys	Arg	Tyr	Asp	Glu	His	His	Gln	Asp	Leu	Thr	Leu	Leu	Lys	
				325						330					335	
gct	ctc	gtg	cgg	cag	cag	ctg	cct	gag	aag	tac	aaa	gag	att	ttc	ttc	1056
Ala	Leu	Val	Arg	Gln	Gln	Leu	Pro	Glu	Lys	Tyr	Lys	Glu	Ile	Phe	Phe	
				340						345					350	
gac	cag	agc	aag	aac	ggc	tac	gcc	ggc	tac	att	gac	ggc	gga	gcc	agc	1104
Asp	Gln	Ser	Lys	Asn	Gly	Tyr	Ala	Gly	Tyr	Ile	Asp	Gly	Gly	Ala	Ser	
				355						360					365	
cag	gaa	gag	ttc	tac	aag	ttc	atc	aag	ccc	atc	ctg	gaa	aag	atg	gac	1152
Gln	Glu	Glu	Phe	Tyr	Lys	Phe	Ile	Lys	Pro	Ile	Leu	Glu	Lys	Met	Asp	
				370						375					380	
ggc	acc	gag	gaa	ctg	ctc	gtg	aag	ctg	aac	aga	gag	gac	ctg	ctg	cgg	1200
Gly	Thr	Glu	Glu	Leu	Leu	Val	Lys	Leu	Asn	Arg	Glu	Asp	Leu	Leu	Arg	
				385						390					400	
aag	cag	cgg	acc	ttc	gac	aac	ggc	agc	atc	ccc	cac	cag	atc	cac	ctg	1248
Lys	Gln	Arg	Thr	Phe	Asp	Asn	Gly	Ser	Ile	Pro	His	Gln	Ile	His	Leu	
				405						410					415	
gga	gag	ctg	cac	gcc	att	ctg	cgg	cgg	cag	gaa	gat	ttt	tac	cca	ttc	1296
Gly	Glu	Leu	His	Ala	Ile	Leu	Arg	Arg	Gln	Glu	Asp	Phe	Tyr	Pro	Phe	
				420						425					430	
ctg	aag	gac	aac	cgg	gaa	aag	atc	gag	aag	atc	ctg	acc	ttc	cgc	atc	1344
Leu	Lys	Asp	Asn	Arg	Glu	Lys	Ile	Glu	Lys	Ile	Leu	Thr	Phe	Arg	Ile	
				435						440					445	
ccc	tac	tac	gtg	ggc	cct	ctg	gcc	agg	gga	aac	agc	aga	ttc	gcc	tgg	1392
Pro	Tyr	Tyr	Val	Gly	Pro	Leu	Ala	Arg	Gly	Asn	Ser	Arg	Phe	Ala	Trp	
				450						455					460	
atg	acc	aga	aag	agc	gag	gaa	acc	atc	acc	ccc	tgg	aac	ttc	gag	gaa	1440
Met	Thr	Arg	Lys	Ser	Glu	Glu	Thr	Ile	Thr	Pro	Trp	Asn	Phe	Glu	Glu	
				465						470					480	
gtg	gtg	gac	aag	ggc	gct	tcc	gcc	cag	agc	ttc	atc	gag	cgg	atg	acc	1488
Val	Val	Asp	Lys	Gly	Ala	Ser	Ala	Gln	Ser	Phe	Ile	Glu	Arg	Met	Thr	

-continued

785	790	795	800	
gtg gaa aac acc cag ctg	cag aac gag aag ctg	tac ctg tac tac ctg		2448
Val Glu Asn Thr Gln Leu	Gln Asn Glu Lys Leu	Tyr Leu Tyr Tyr Leu		
	805	810	815	
cag aat ggg cgg gat atg	tac gtg gac cag gaa	ctg gac atc aac cgg		2496
Gln Asn Gly Arg Asp Met	Tyr Val Asp Gln Glu	Leu Asp Ile Asn Arg		
	820	825	830	
ctg tcc gac tac gat gtg	gac gcc atc gtg cct	cag agc ttt ctg aag		2544
Leu Ser Asp Tyr Asp Val	Asp Ala Ile Val Pro	Gln Ser Phe Leu Lys		
	835	840	845	
gac gac tcc atc gac gcc	aag gtg ctg acc aga	agc gac aag gcc cgg		2592
Asp Asp Ser Ile Asp Ala	Lys Val Leu Thr Arg	Ser Asp Lys Ala Arg		
	850	855	860	
ggc aag agc gac aac gtg	ccc tcc gaa gag gtc	gtg aag aag atg aag		2640
Gly Lys Ser Asp Asn Val	Pro Ser Glu Glu Val	Val Val Lys Lys Met	Lys	
	865	870	875	880
aac tac tgg cgg cag ctg	ctg aac gcc aag ctg	att acc cag aga aag		2688
Asn Tyr Trp Arg Gln Leu	Leu Asn Ala Lys Leu	Ile Thr Gln Arg Lys		
	885	890	895	
ttc gac aat ctg acc aag	gcc gag aga ggc ggc	ctg agc gaa ctg gat		2736
Phe Asp Asn Leu Thr Lys	Ala Glu Arg Gly Gly	Leu Ser Glu Leu Asp		
	900	905	910	
aag gcc ggc ttc atc aag	aga cag ctg gtg gaa	acc cgg cag atc aca		2784
Lys Ala Gly Phe Ile Lys	Arg Gln Leu Val Glu	Thr Arg Gln Ile Thr		
	915	920	925	
aag cac gtg gca cag atc	ctg gac tcc cgg atg	aac act aag tac gac		2832
Lys His Val Ala Gln Ile	Leu Asp Ser Arg Met	Asn Thr Lys Tyr Asp		
	930	935	940	
gag aat gac aag ctg atc	cgg gaa gtg aaa gtg	atc acc ctg aag tcc		2880
Glu Asn Asp Lys Leu Ile	Arg Glu Val Lys Val	Ile Thr Leu Lys Ser		
	945	950	955	960
aag ctg gtg tcc gat ttc	cgg aag gat ttc cag	ttt tac aaa gtg cgc		2928
Lys Leu Val Ser Asp Phe	Arg Lys Asp Phe Gln	Phe Tyr Lys Val Arg		
	965	970	975	
gag atc aac aac tac cac	cac gcc cac gcc gcc	tac ctg aac gcc gtc		2976
Glu Ile Asn Asn Tyr His	His Ala His Ala Ala	Tyr Leu Asn Ala Val		
	980	985	990	
gtg gga acc gcc ctg atc	aaa aag tac cct aag	ctg gaa agc gag ttc		3024
Val Gly Thr Ala Leu Ile	Lys Lys Tyr Pro Lys	Leu Glu Ser Glu Phe		
	995	1000	1005	
gtg tac ggc gac tac aag	gtg tac gac gtg cgg	aag atg atc gcc		3069
Val Tyr Gly Asp Tyr Lys	Val Tyr Asp Val Arg	Lys Met Ile Ala		
	1010	1015	1020	
aag agc gag cag gaa atc	ggc aag gct acc gcc	aag tac ttc ttc		3114
Lys Ser Glu Gln Glu Ile	Gly Lys Ala Thr Ala	Lys Tyr Phe Phe		
	1025	1030	1035	
tac agc aac atc atg aac	ttt ttc aag acc gag	att acc ctg gcc		3159
Tyr Ser Asn Ile Met Asn	Phe Lys Thr Glu Ile	Thr Leu Ala		
	1040	1045	1050	
aac ggc gag atc cgg aag	cgg cct ctg atc gag	aca aac ggc gaa		3204
Asn Gly Glu Ile Arg Lys	Arg Pro Leu Ile Glu	Thr Asn Gly Glu		
	1055	1060	1065	
acc ggg gag atc gtg tgg	gat aag ggc cgg gat	ttt gcc acc gtg		3249
Thr Gly Glu Ile Val Trp	Asp Lys Gly Arg Asp	Phe Ala Thr Val		
	1070	1075	1080	
cgg aaa gtg ctg agc atg	ccc caa gtg aat atc	gtg aaa aag acc		3294
Arg Lys Val Leu Ser Met	Pro Gln Val Asn Ile	Val Lys Lys Thr		

-continued

1085	1090	1095	
gag gtg cag aca ggc ggc ttc agc aaa gag tct atc ctg ccc aag Glu Val Gln Thr Gly Gly Phe Ser Lys Glu Ser Ile Leu Pro Lys 1100 1105 1110			3339
agg aac agc gat aag ctg atc gcc aga aag aag gac tgg gac cct Arg Asn Ser Asp Lys Leu Ile Ala Arg Lys Lys Asp Trp Asp Pro 1115 1120 1125			3384
aag aag tac ggc ggc ttc gac agc ccc acc gtg gcc tat tct gtg Lys Lys Tyr Gly Gly Phe Asp Ser Pro Thr Val Ala Tyr Ser Val 1130 1135 1140			3429
ctg gtg gtg gcc aaa gtg gaa aag ggc aag tcc aag aaa ctg aag Leu Val Val Ala Lys Val Glu Lys Gly Lys Ser Lys Lys Leu Lys 1145 1150 1155			3474
agt gtg aaa gag ctg ctg ggg atc acc atc atg gaa aga agc agc Ser Val Lys Glu Leu Leu Gly Ile Thr Ile Met Glu Arg Ser Ser 1160 1165 1170			3519
ttc gag aag aat ccc atc gac ttt ctg gaa gcc aag ggc tac aaa Phe Glu Lys Asn Pro Ile Asp Phe Leu Glu Ala Lys Gly Tyr Lys 1175 1180 1185			3564
gaa gtg aaa aag gac ctg atc atc aag ctg cct aag tac tcc ctg Glu Val Lys Lys Asp Leu Ile Ile Lys Leu Pro Lys Tyr Ser Leu 1190 1195 1200			3609
ttc gag ctg gaa aac ggc cgg aag aga atg ctg gcc tct gcc ggc Phe Glu Leu Glu Asn Gly Arg Lys Arg Met Leu Ala Ser Ala Gly 1205 1210 1215			3654
gaa ctg cag aag gga aac gaa ctg gcc ctg ccc tcc aaa tat gtg Glu Leu Gln Lys Gly Asn Glu Leu Ala Leu Pro Ser Lys Tyr Val 1220 1225 1230			3699
aac ttc ctg tac ctg gcc agc cac tat gag aag ctg aag ggc tcc Asn Phe Leu Tyr Leu Ala Ser His Tyr Glu Lys Leu Lys Gly Ser 1235 1240 1245			3744
ccc gag gat aat gag cag aaa cag ctg ttt gtg gaa cag cac aag Pro Glu Asp Asn Glu Gln Lys Gln Leu Phe Val Glu Gln His Lys 1250 1255 1260			3789
cac tac ctg gac gag atc atc gag cag atc agc gag ttc tcc aag His Tyr Leu Asp Glu Ile Ile Glu Gln Ile Ser Glu Phe Ser Lys 1265 1270 1275			3834
aga gtg atc ctg gcc gac gct aat ctg gac aaa gtg ctg tcc gcc Arg Val Ile Leu Ala Asp Ala Asn Leu Asp Lys Val Leu Ser Ala 1280 1285 1290			3879
tac aac aag cac cgg gat aag ccc atc aga gag cag gcc gag aat Tyr Asn Lys His Arg Asp Lys Pro Ile Arg Glu Gln Ala Glu Asn 1295 1300 1305			3924
atc atc cac ctg ttt acc ctg acc aat ctg gga gcc cct gcc gcc Ile Ile His Leu Phe Thr Leu Thr Asn Leu Gly Ala Pro Ala Ala 1310 1315 1320			3969
ttc aag tac ttt gac acc acc atc gac cgg aag agg tac acc agc Phe Lys Tyr Phe Asp Thr Thr Ile Asp Arg Lys Arg Tyr Thr Ser 1325 1330 1335			4014
acc aaa gag gtg ctg gac gcc acc ctg atc cac cag agc atc acc Thr Lys Glu Val Leu Asp Ala Thr Leu Ile His Gln Ser Ile Thr 1340 1345 1350			4059
ggc ctg tac gag aca cgg atc gac ctg tct cag ctg gga ggc gac Gly Leu Tyr Glu Thr Arg Ile Asp Leu Ser Gln Leu Gly Gly Asp 1355 1360 1365			4104

-continued

```

<211> LENGTH: 1368
<212> TYPE: PRT
<213> ORGANISM: Homo sapiens

<400> SEQUENCE: 502

Met Asp Lys Lys Tyr Ser Ile Gly Leu Asp Ile Gly Thr Asn Ser Val
1          5          10          15
Gly Trp Ala Val Ile Thr Asp Glu Tyr Lys Val Pro Ser Lys Lys Phe
20          25          30
Lys Val Leu Gly Asn Thr Asp Arg His Ser Ile Lys Lys Asn Leu Ile
35          40          45
Gly Ala Leu Leu Phe Asp Ser Gly Glu Thr Ala Glu Ala Thr Arg Leu
50          55          60
Lys Arg Thr Ala Arg Arg Arg Tyr Thr Arg Arg Lys Asn Arg Ile Cys
65          70          75          80
Tyr Leu Gln Glu Ile Phe Ser Asn Glu Met Ala Lys Val Asp Asp Ser
85          90          95
Phe Phe His Arg Leu Glu Glu Ser Phe Leu Val Glu Glu Asp Lys Lys
100         105         110
His Glu Arg His Pro Ile Phe Gly Asn Ile Val Asp Glu Val Ala Tyr
115         120         125
His Glu Lys Tyr Pro Thr Ile Tyr His Leu Arg Lys Lys Leu Val Asp
130         135         140
Ser Thr Asp Lys Ala Asp Leu Arg Leu Ile Tyr Leu Ala Leu Ala His
145         150         155         160
Met Ile Lys Phe Arg Gly His Phe Leu Ile Glu Gly Asp Leu Asn Pro
165         170         175
Asp Asn Ser Asp Val Asp Lys Leu Phe Ile Gln Leu Val Gln Thr Tyr
180         185         190
Asn Gln Leu Phe Glu Glu Asn Pro Ile Asn Ala Ser Gly Val Asp Ala
195         200         205
Lys Ala Ile Leu Ser Ala Arg Leu Ser Lys Ser Arg Arg Leu Glu Asn
210         215         220
Leu Ile Ala Gln Leu Pro Gly Glu Lys Lys Asn Gly Leu Phe Gly Asn
225         230         235         240
Leu Ile Ala Leu Ser Leu Gly Leu Thr Pro Asn Phe Lys Ser Asn Phe
245         250         255
Asp Leu Ala Glu Asp Ala Lys Leu Gln Leu Ser Lys Asp Thr Tyr Asp
260         265         270
Asp Asp Leu Asp Asn Leu Leu Ala Gln Ile Gly Asp Gln Tyr Ala Asp
275         280         285
Leu Phe Leu Ala Ala Lys Asn Leu Ser Asp Ala Ile Leu Leu Ser Asp
290         295         300
Ile Leu Arg Val Asn Thr Glu Ile Thr Lys Ala Pro Leu Ser Ala Ser
305         310         315         320
Met Ile Lys Arg Tyr Asp Glu His His Gln Asp Leu Thr Leu Leu Lys
325         330         335
Ala Leu Val Arg Gln Gln Leu Pro Glu Lys Tyr Lys Glu Ile Phe Phe
340         345         350
Asp Gln Ser Lys Asn Gly Tyr Ala Gly Tyr Ile Asp Gly Gly Ala Ser
355         360         365
Gln Glu Glu Phe Tyr Lys Phe Ile Lys Pro Ile Leu Glu Lys Met Asp

```

-continued

370			375			380									
Gly	Thr	Glu	Glu	Leu	Leu	Val	Lys	Leu	Asn	Arg	Glu	Asp	Leu	Leu	Arg
385					390					395					400
Lys	Gln	Arg	Thr	Phe	Asp	Asn	Gly	Ser	Ile	Pro	His	Gln	Ile	His	Leu
				405					410					415	
Gly	Glu	Leu	His	Ala	Ile	Leu	Arg	Arg	Gln	Glu	Asp	Phe	Tyr	Pro	Phe
			420					425					430		
Leu	Lys	Asp	Asn	Arg	Glu	Lys	Ile	Glu	Lys	Ile	Leu	Thr	Phe	Arg	Ile
		435					440					445			
Pro	Tyr	Tyr	Val	Gly	Pro	Leu	Ala	Arg	Gly	Asn	Ser	Arg	Phe	Ala	Trp
450						455					460				
Met	Thr	Arg	Lys	Ser	Glu	Glu	Thr	Ile	Thr	Pro	Trp	Asn	Phe	Glu	Glu
465					470					475					480
Val	Val	Asp	Lys	Gly	Ala	Ser	Ala	Gln	Ser	Phe	Ile	Glu	Arg	Met	Thr
				485					490						495
Asn	Phe	Asp	Lys	Asn	Leu	Pro	Asn	Glu	Lys	Val	Leu	Pro	Lys	His	Ser
			500					505						510	
Leu	Leu	Tyr	Glu	Tyr	Phe	Thr	Val	Tyr	Asn	Glu	Leu	Thr	Lys	Val	Lys
		515					520						525		
Tyr	Val	Thr	Glu	Gly	Met	Arg	Lys	Pro	Ala	Phe	Leu	Ser	Gly	Glu	Gln
530						535					540				
Lys	Lys	Ala	Ile	Val	Asp	Leu	Leu	Phe	Lys	Thr	Asn	Arg	Lys	Val	Thr
545					550					555					560
Val	Lys	Gln	Leu	Lys	Glu	Asp	Tyr	Phe	Lys	Lys	Ile	Glu	Cys	Phe	Asp
				565					570						575
Ser	Val	Glu	Ile	Ser	Gly	Val	Glu	Asp	Arg	Phe	Asn	Ala	Ser	Leu	Gly
			580					585						590	
Thr	Tyr	His	Asp	Leu	Leu	Lys	Ile	Ile	Lys	Asp	Lys	Asp	Phe	Leu	Asp
		595					600						605		
Asn	Glu	Glu	Asn	Glu	Asp	Ile	Leu	Glu	Asp	Ile	Val	Leu	Thr	Leu	Thr
610						615					620				
Leu	Phe	Glu	Asp	Arg	Glu	Met	Ile	Glu	Glu	Arg	Leu	Lys	Thr	Tyr	Ala
625					630					635					640
His	Leu	Phe	Asp	Asp	Lys	Val	Met	Lys	Gln	Leu	Lys	Arg	Arg	Arg	Tyr
				645					650						655
Thr	Gly	Trp	Gly	Arg	Leu	Ser	Arg	Lys	Leu	Ile	Asn	Gly	Ile	Arg	Asp
			660					665						670	
Lys	Gln	Ser	Gly	Lys	Thr	Ile	Leu	Asp	Phe	Leu	Lys	Ser	Asp	Gly	Phe
		675					680						685		
Ala	Asn	Arg	Asn	Phe	Met	Gln	Leu	Ile	His	Asp	Asp	Ser	Leu	Thr	Phe
690						695					700				
Lys	Glu	Asp	Ile	Gln	Lys	Ala	Gln	Val	Ser	Gly	Gln	Gly	Asp	Ser	Leu
705					710					715					720
His	Glu	His	Ile	Ala	Asn	Leu	Ala	Gly	Ser	Pro	Ala	Ile	Lys	Lys	Gly
				725					730						735
Ile	Leu	Gln	Thr	Val	Lys	Val	Val	Asp	Glu	Leu	Val	Lys	Val	Met	Gly
			740					745						750	
Arg	His	Lys	Pro	Glu	Asn	Ile	Val	Ile	Ala	Met	Ala	Arg	Glu	Asn	Gln
		755					760						765		
Thr	Thr	Gln	Lys	Gly	Gln	Lys	Asn	Ser	Arg	Glu	Arg	Met	Lys	Arg	Ile
770						775							780		

-continued

Glu Glu Gly Ile Lys Glu Leu Gly Ser Gln Ile Leu Lys Glu His Pro
 785 790 795 800
 Val Glu Asn Thr Gln Leu Gln Asn Glu Lys Leu Tyr Leu Tyr Tyr Leu
 805 810 815
 Gln Asn Gly Arg Asp Met Tyr Val Asp Gln Glu Leu Asp Ile Asn Arg
 820 825 830
 Leu Ser Asp Tyr Asp Val Asp Ala Ile Val Pro Gln Ser Phe Leu Lys
 835 840 845
 Asp Asp Ser Ile Asp Ala Lys Val Leu Thr Arg Ser Asp Lys Ala Arg
 850 855 860
 Gly Lys Ser Asp Asn Val Pro Ser Glu Glu Val Val Lys Lys Met Lys
 865 870 875 880
 Asn Tyr Trp Arg Gln Leu Leu Asn Ala Lys Leu Ile Thr Gln Arg Lys
 885 890 895
 Phe Asp Asn Leu Thr Lys Ala Glu Arg Gly Gly Leu Ser Glu Leu Asp
 900 905 910
 Lys Ala Gly Phe Ile Lys Arg Gln Leu Val Glu Thr Arg Gln Ile Thr
 915 920 925
 Lys His Val Ala Gln Ile Leu Asp Ser Arg Met Asn Thr Lys Tyr Asp
 930 935 940
 Glu Asn Asp Lys Leu Ile Arg Glu Val Lys Val Ile Thr Leu Lys Ser
 945 950 955 960
 Lys Leu Val Ser Asp Phe Arg Lys Asp Phe Gln Phe Tyr Lys Val Arg
 965 970 975
 Glu Ile Asn Asn Tyr His His Ala His Ala Ala Tyr Leu Asn Ala Val
 980 985 990
 Val Gly Thr Ala Leu Ile Lys Lys Tyr Pro Lys Leu Glu Ser Glu Phe
 995 1000 1005
 Val Tyr Gly Asp Tyr Lys Val Tyr Asp Val Arg Lys Met Ile Ala
 1010 1015 1020
 Lys Ser Glu Gln Glu Ile Gly Lys Ala Thr Ala Lys Tyr Phe Phe
 1025 1030 1035
 Tyr Ser Asn Ile Met Asn Phe Phe Lys Thr Glu Ile Thr Leu Ala
 1040 1045 1050
 Asn Gly Glu Ile Arg Lys Arg Pro Leu Ile Glu Thr Asn Gly Glu
 1055 1060 1065
 Thr Gly Glu Ile Val Trp Asp Lys Gly Arg Asp Phe Ala Thr Val
 1070 1075 1080
 Arg Lys Val Leu Ser Met Pro Gln Val Asn Ile Val Lys Lys Thr
 1085 1090 1095
 Glu Val Gln Thr Gly Gly Phe Ser Lys Glu Ser Ile Leu Pro Lys
 1100 1105 1110
 Arg Asn Ser Asp Lys Leu Ile Ala Arg Lys Lys Asp Trp Asp Pro
 1115 1120 1125
 Lys Lys Tyr Gly Gly Phe Asp Ser Pro Thr Val Ala Tyr Ser Val
 1130 1135 1140
 Leu Val Val Ala Lys Val Glu Lys Gly Lys Ser Lys Lys Leu Lys
 1145 1150 1155
 Ser Val Lys Glu Leu Leu Gly Ile Thr Ile Met Glu Arg Ser Ser
 1160 1165 1170

-continued

Phe Glu Lys Asn Pro Ile Asp Phe Leu Glu Ala Lys Gly Tyr Lys
 1175 1180 1185

Glu Val Lys Lys Asp Leu Ile Ile Lys Leu Pro Lys Tyr Ser Leu
 1190 1195 1200

Phe Glu Leu Glu Asn Gly Arg Lys Arg Met Leu Ala Ser Ala Gly
 1205 1210 1215

Glu Leu Gln Lys Gly Asn Glu Leu Ala Leu Pro Ser Lys Tyr Val
 1220 1225 1230

Asn Phe Leu Tyr Leu Ala Ser His Tyr Glu Lys Leu Lys Gly Ser
 1235 1240 1245

Pro Glu Asp Asn Glu Gln Lys Gln Leu Phe Val Glu Gln His Lys
 1250 1255 1260

His Tyr Leu Asp Glu Ile Ile Glu Gln Ile Ser Glu Phe Ser Lys
 1265 1270 1275

Arg Val Ile Leu Ala Asp Ala Asn Leu Asp Lys Val Leu Ser Ala
 1280 1285 1290

Tyr Asn Lys His Arg Asp Lys Pro Ile Arg Glu Gln Ala Glu Asn
 1295 1300 1305

Ile Ile His Leu Phe Thr Leu Thr Asn Leu Gly Ala Pro Ala Ala
 1310 1315 1320

Phe Lys Tyr Phe Asp Thr Thr Ile Asp Arg Lys Arg Tyr Thr Ser
 1325 1330 1335

Thr Lys Glu Val Leu Asp Ala Thr Leu Ile His Gln Ser Ile Thr
 1340 1345 1350

Gly Leu Tyr Glu Thr Arg Ile Asp Leu Ser Gln Leu Gly Gly Asp
 1355 1360 1365

<210> SEQ ID NO 503
 <211> LENGTH: 15
 <212> TYPE: DNA
 <213> ORGANISM: Homo sapiens

<400> SEQUENCE: 503

cagaagaaga agggc

15

<210> SEQ ID NO 504
 <211> LENGTH: 51
 <212> TYPE: DNA
 <213> ORGANISM: Homo sapiens

<400> SEQUENCE: 504

ccaatgggga ggacatcgat gtcacctcca atgactaggg tgggtgggcaa c

51

<210> SEQ ID NO 505
 <211> LENGTH: 15
 <212> TYPE: DNA
 <213> ORGANISM: Homo sapiens

<400> SEQUENCE: 505

ctctggccac tccct

15

<210> SEQ ID NO 506
 <211> LENGTH: 52
 <212> TYPE: DNA
 <213> ORGANISM: Homo sapiens

<400> SEQUENCE: 506

-continued

 acatcgatgt cacctccaat gacaagcttg ctagecgttg gcaaccacaa ac 52

<210> SEQ ID NO 507
 <211> LENGTH: 1733
 <212> TYPE: DNA
 <213> ORGANISM: Artificial Sequence
 <220> FEATURE:
 <223> OTHER INFORMATION: Description of Artificial Sequence: Synthetic polynucleotide

<400> SEQUENCE: 507

ccgtttaaac aattctgcag gaatctagtt attaatagta atcaattacg gggtcattag 60
 ttcataagccc atatatggag ttccgcgta cataacttac ggtaaatggc ccgcctggct 120
 gaccgcccac cgacccccgc ccattgacgt caataatgac gtatgttccc atagtaacgc 180
 caatagggac tttccattga cgtcaatggg tggagtattt acggtaaaact gcccaacttg 240
 cagtacatca agtgtatcat atgccaaagta cgccccctat tgacgtcaat gacggtaaat 300
 ggcccgcctg gcattatgcc cagtacatga ccttatggga ctttctact tggcagtaca 360
 tctacgtatt agtcatcgct attaccatgg tcgagggtgag cccacacgttc tgcttcaact 420
 tccccatctc cccccctcc cccccccaa ttttgtattt atttattttt taattatttt 480
 gtgcagcgat gggggcgggg gggggggggg ggcgcgcgcc aggcggggcg gggcggggcg 540
 aggggcgggg cggggcgagg cggagagggtg cggcggcagc caatcagagc ggcgcgctcc 600
 gaaagtttcc ttttatggcg aggcggcggc ggcggcggcc ctataaaaag cgaagcgcgc 660
 ggcgggcgga agtcgctgcg cgtgccttc gccccgtgcc ccgctccgcc gccgcctcgc 720
 gccgcccgcc ccggctctga ctgaccgct tactcccaca ggtgagcggg cgggacggcc 780
 cttctctcc cggctgtaat tagcgttggt tttaatgacg gcttgtttct tttctgtggc 840
 tgcgtaaaag ccttgagggg ctccgggagg gccctttgtg cggggggagc ggctcggggg 900
 gtgcgtgctg gtgtgtgtgc gtggggagcg ccgcgtgctg ctccgcgctg cccggcgct 960
 gtgagcgtg cgggcgcggc gcggggcttt gtgcgctccg cagtgtgcgc gaggggagcg 1020
 cggccggggg cgggtccccc cgtgccccgg ggggctgcga ggggaacaaa ggctcgtgctc 1080
 ggggtgtgtg cgtggggggg tgagcagggg gtgtgggggc gtcggtcggg ctgcaacccc 1140
 cctctcaccc cctccccga gttgctgagc acggccccgc ttccgggtgcg gggctccgta 1200
 cggggcgtgg cgcggggctc gccgtgccgg gcgggggggtg gcggcaggtg ggggtgccgg 1260
 gcggggcggg gccgcctcgg gccggggagg gctcggggga ggggcgcggc ggcccccgga 1320
 gcgcggcgcg ctgtcgaggg gcggcgagcc gcagccattg ccttttatgg taatcgtgcg 1380
 agagggcgca gggacttctt ttgtccaaa tctgtgcgga gccgaaatct gggaggcgcc 1440
 gccgcacccc ctctagcggg cgcggggcga agcgggtcgg cgcgggcagg aaggaaatgg 1500
 gcggggaggg ccttctgctg tcgcgcgcc gccgtccctc tctccctctc cagcctcggg 1560
 gctgtcccg gggggacggc tgccctcggg ggggacgggg caggggcggg ttcggcttct 1620
 ggcgtgtgac cggcgctctc agagcctctg ctaaccatgt tcatgccttc ttctttttcc 1680
 tacagctcct gggcaacgtg ctggttattg tgctgtctca tcattttggc aaa 1733

<210> SEQ ID NO 508
 <211> LENGTH: 4269
 <212> TYPE: DNA

-continued

<213> ORGANISM: Artificial Sequence

<220> FEATURE:

<223> OTHER INFORMATION: Description of Artificial Sequence: Synthetic polynucleotide

<400> SEQUENCE: 508

```

atggactata aggaccacga cggagactac aaggatcatg atattgatta caaagacgat    60
gacgataaga tggcccaaaa gaagaagcgg aaggtcggta tccacggagt cccagcagcc    120
gacaagaagt acagcatcgg cctggacatc ggcaccaact ctgtgggctg ggccgtgatc    180
accgacgagt acaaggtgcc cagcaagaaa ttcaaggtgc tgggcaaacac cgaccggcac    240
agcatcaaga agaacctgat cggagccctg ctgttcgaca gcggcgaaac agccgaggcc    300
acccggctga agagaaccgc cagaagaaga tacaccagac ggaagaaccg gatctgctat    360
ctgcaagaga tcttcagcaa cgagatggcc aagggtggacg acagcttctt ccacagactg    420
gaagagtctt tcctggtgga agaggataag aagcacgagc ggcaccccat ctteggaac    480
atcgtggacg aggtggccta ccacgagaag taccaccaca tctaccacct gagaaagaaa    540
ctggtggaca gcaccgacaa ggccgacctg cggtgatctt atctggccct ggcccacatg    600
atcaagtcc  ggggccactt cctgatcgag ggcgacctga accccgacaa cagcgacgtg    660
gacaagctgt tcattccagct ggtgcagacc tacaaccagc tggtcgagga aaaccccatc    720
aacgccagcg gcgtggacgc caaggccatc ctgtctgcc  gactgagcaa gagcagacgg    780
ctggaatac  tgatcgcca gctgccggc  gagaagaaga atggcctgtt cgaaaactg    840
attgccctga gcctgggctt gacccccaac ttcaagagca acttcgacct ggccgaggat    900
gccccactgc agctgagcaa ggacacctac gacgacgacc tggacaacct gctggcccag    960
atcgcgacc  agtacccga cctgtttctg gccgccaaga acctgtccga cgccatcctg   1020
ctgagcgaca tcctgagagt gaacaccgag atcaccaagg cccccctgag cgctctatg   1080
atcaagagat acgacgagca ccaccaggac ctgacctgc  tgaaagctct cgtgctggcag   1140
cagctgcctg agaagtaaaa agagattttc ttcgaccaga gcaagaacgg ctacgcccggc   1200
tacattgacg gcggagccag ccaggaagag ttctacaagt tcatcaagcc catcctggaa   1260
aagatggacg gcaccgagga actgctcgtg aagctgaaca gagaggacct gctgctggaag   1320
cagcggacct tcgacaacgg cagcatcccc caccagatcc acctgggaga gctgcaagcc   1380
attctgcggc ggcaggaaga tttttacca ttctgaagg  acaaccggga aaagatcgag   1440
aagatcctga ccttcgcat  ccctactac gtgggcccctc tggccagggg aaacagcaga   1500
ttcgctgga  tgaccagaaa gagcagggaa accatcccc  cctggaactt cgaggaagtg   1560
gtggacaagg gcgcttcgcg ccagagcttc atcgagcgg  tgaccaactt cgataagaac   1620
ctgcccacag agaaggtgct gcccagcac  agcctgctgt acgagtactt caccgtgat   1680
aacgagctga ccaaagtgaa atacgtgacc gagggaatga gaaagcccgc cttcctgagc   1740
ggcgagcaga aaaaggccat cgtggacctg ctgttcaaga ccaaccggaa agtgaccgtg   1800
aagcagctga aagaggacta cttcaagaaa atcgagtgtc tcgactcgtg ggaatctcc   1860
ggcgtggaag atcggttcaa cgctccctg  ggcacatacc acgatctgct gaaaattatc   1920
aaggacaagg acttcctgga caatgaggaa aacgaggaca ttctggaaga tatcgtgctg   1980
accctgacac tgtttgagga cagagagatg atcgaggaac ggctgaaaac ctatgccac   2040
ctgttcgacg acaagtgat  gaagcagctg aagcggcgga gataaccgg  ctggggcag   2100

```

-continued

ctgagccgga agctgatcaa cggcatcccg gacaagcagt cggcaagac aatcctggat	2160
ttcctgaagt cgcagcgtt cgccaacaga aacttcatgc agctgatcca cgacgacagc	2220
ctgaccttta aagaggacat ccagaaagcc caggtgtccg gccagggcga tagcctgcac	2280
gagcacattg ccaatctggc cggcagcccc gccattaaga agggcatcct gcagacagtg	2340
aagtggtgg acgagctcgt gaaagtgatg ggccggcaca agcccagaaa catcgtgatc	2400
gaaatggcca gagagaacca gaccacccag aagggacaga agaacagccg cgagagaatg	2460
aagcggatcg aagaggcat caaagagctg ggcagccaga tcctgaaaga acaccccggtg	2520
gaaaacacc agctgcagaa cgagaagctg tacctgtact acctgcagaa tgggcgggat	2580
atgtacgtgg accaggaact ggacatcaac cggctgtccg actacgatgt ggaccatc	2640
gtgcctcaga gctttctgaa ggacgactcc atcgacaaca aggtgctgac cagaagcgac	2700
aagaaccggg gcaagagcga caacgtgcc tccgaagagg tcgtgaagaa gatgaagaac	2760
tactggcggc agctgctgaa cgccaagctg attaccaga gaaagttcga caatctgacc	2820
aaggccgaga gagggcgct gagcgaactg gataaggccg gcttcatcaa gagacagctg	2880
gtgaaaccc ggcagatcac aaagcagctg gcacagatcc tggactcccg gatgaacact	2940
aagtacgacg agaatgacaa gctgatcccg gaagtgaag tgatcacctt gaagtccaag	3000
ctggtgtccg atttccgaa ggatttccag ttttacaag tgccgagat caacaactac	3060
caccacgccc acgacgccta cctgaacgcc gtcgtgggaa ccgcccgat caaaaagtac	3120
cctaagctgg aaagcgagtt cgtgtacggc gactacaagg tgtacgacgt gcggaagatg	3180
atcgccaaga gcgagcagga aatcggaag gctaccgcca agtacttctt ctacagcaac	3240
atcatgaact tttcaagac cgagattacc ctggccaacg gcgagatccg gaagcggcct	3300
ctgatcgaga caaacggcga aaccggggag atcgtgtggg ataagggccg ggattttgcc	3360
accgtgcgga aagtgtctgag catgccccaa gtgaatatcg tgaaaaagac cgaggtgcag	3420
acagcggct tcagcaaaga gtctatcctg cccaagagga acagcgataa gctgatcgcc	3480
agaaagaagg actgggccc taagaagtac ggcggcttcg acagccccac cgtggcctat	3540
tctgtctgg tgggtggcaa agtggaaaag ggcaagtcca agaaactgaa gagtgtgaaa	3600
gagctgctgg ggatcacat catggaaga agcagcttcg agaagaatcc catcgacttt	3660
ctggaagcca agggctacaa agaagtgaaa aaggacctga tcatcaagct gcctaagtac	3720
tcctgttctg agctggaaaa cggccggaag agaatgctgg cctctgccgg cgaactgcag	3780
aagggaaacg aactggcctt gccctccaaa tatgtgaact tcctgtacct ggccagccac	3840
tatgagaagc tgaagggctc ccccgaggat aatgagcaga aacagctggt tgtggaacag	3900
cacaagcact acctggacga gatcatcgag cagatcagcg agttctccaa gagagtgatc	3960
ctggccgacg ctaatctgga caaagtgtg tccgcctaca acaagcaccg ggataagccc	4020
atcagagagc aggcgagaa tatcatccac ctgtttaccc tgaccaatct gggagcccct	4080
gccgccttca agtactttga caccaccatc gaccggaaga ggtacaccag caccaaagag	4140
gtgctggacg ccaccctgat ccaccagac atcaccggcc tgtacgagac acggatcgac	4200
ctgtctcagc tgggagcgga caaaagggcg gcggccacga aaaagggcgg ccaggcaaaa	4260
aagaaaaag	4269

-continued

<210> SEQ ID NO 509
<211> LENGTH: 780
<212> TYPE: DNA
<213> ORGANISM: Artificial Sequence
<220> FEATURE:
<223> OTHER INFORMATION: Description of Artificial Sequence: Synthetic polynucleotide

<400> SEQUENCE: 509

ggaagcggag ccactaactt ctcctgttg aaacaagcag gggatgtcga agagaatccc	60
gggccagtga gcaagggcga ggagctgttc accggggtgg tgcccactct ggtcgagctg	120
gacggcgacg taaacggcca caagtgcagc gtgtccggcg agggcgaggg cgatgccacc	180
tacggcaagc tgaccctgaa gttcatctgc accaccggca agctgcccgt gccctggccc	240
accctcgtga ccaccctgac ctacggcgtg cagtgttca gccctaccc cgaccacatg	300
aagcagcacg acttcttcaa gtccgccatg cccgaaggct acgtccagga gcgcaccatc	360
ttcttcaagg acgacggcaa ctacaagacc cgcgccgagg tgaagttcga gggcgacacc	420
ctggtgaacc gcatcgagct gaagggcatc gacttcaagg aggacggcaa catcctgggg	480
cacaagctgg agtacaacta caacagccac aacgtctata tcatggccga caagcagaag	540
aacggcatca aggtgaaact caagatccgc cacaacatcg aggacggcag cgtgcagctc	600
gccgaccact accagcagaa caccctcacc ggcgacggcc ccgtgctgct gcccgacaac	660
cactacctga gcaccagtc cgccctgagc aaagacccca acgagaagcg cgatcacatg	720
gtcctgctgg agttcgtgac cgcgccgggg atcactctcg gcatggacga gctgtacaag	780

<210> SEQ ID NO 510
<211> LENGTH: 597
<212> TYPE: DNA
<213> ORGANISM: Artificial Sequence
<220> FEATURE:
<223> OTHER INFORMATION: Description of Artificial Sequence: Synthetic polynucleotide

<400> SEQUENCE: 510

cgataatcaa cctctggatt acaaaatttg tgaaagattg actggattc ttaactatgt	60
tgctcctttt acgctatgtg gatacctgac tttaatgcct ttgtatcatg ctattgcttc	120
ccgatatggt ttcattttct cctccttgta taaatcctgg ttgctgtctc tttatgagga	180
gttgtggccc gttgtcaggc aacgtggcgt ggtgtgcact gtgtttgctg acgcaacccc	240
cactgggttg ggcattgcca ccacctgtca gctcctttcc gggactttcg ctttccccct	300
ccctattgcc acggcggaac tcatcgccgc ctgccttgcc cgctgctgga caggggctcg	360
gctgttgggc actgacaatt ccgtggtgtt gtcggggaaa tcatcgtcct ttccttggtc	420
gctcgcctgt gttgccacct ggattctgcg cgggaagctc ttctgctacg tcccttcggc	480
cctcaatcca gcggaccttc cttcccggcg cctgctgccg gctctgcggc ctcttccggc	540
tcttcgcctt cgcctcaga cgagtcggat ctcctttgg gccgcctccc cgcacg	597

<210> SEQ ID NO 511
<211> LENGTH: 210
<212> TYPE: DNA
<213> ORGANISM: Artificial Sequence
<220> FEATURE:
<223> OTHER INFORMATION: Description of Artificial Sequence: Synthetic polynucleotide

-continued

<400> SEQUENCE: 511

```
cgacctcgac tgtgccttct agttgccagc catctgttgt ttgcccctcc cccgtgcctt    60
ccttgacctt ggaaggtgcc actcccactg tcctttccta ataaaatgag gaaattgcat    120
cgcattgtct gagtaggtgt cattctattc tgggggggtg ggtggggcag gacagcaagg    180
gggaggattg ggaagacaat ggcaggcatg                                     210
```

<210> SEQ ID NO 512

<211> LENGTH: 906

<212> TYPE: DNA

<213> ORGANISM: Artificial Sequence

<220> FEATURE:

<223> OTHER INFORMATION: Description of Artificial Sequence: Synthetic polynucleotide

<220> FEATURE:

<221> NAME/KEY: modified_base

<222> LOCATION: (109)..(109)

<223> OTHER INFORMATION: a, c, t, g, unknown or other

<220> FEATURE:

<221> NAME/KEY: modified_base

<222> LOCATION: (135)..(135)

<223> OTHER INFORMATION: a, c, t, g, unknown or other

<400> SEQUENCE: 512

```
ataacttcgt ataatgtatg ctatacgaag ttattcgcg tgaataaatg aaagcttgca    60
gatctgcgac tctagaggat ctgcgactct agaggatcat aatcagcctt accacatttt    120
gtagaggttt tactngcttt aaaaaacctc ccacacctcc cctgaaactt gaaacataaa    180
atgaatgcaa ttgttgttgt taacttgttt attgcagctt ataatggta caaataaagc    240
aatagcatca caaatttcac aaataaagca tttttttcac tgcattctag ttgtggtttg    300
tccaaactca tcaatgtatc ttatcatgtc tggatctgcy actctagagg atcataatca    360
gccataccac attttagag gttttacttg ctttaaaaaa cctcccacac ctcccctga    420
acctgaaaca taaaatgaat gcaattgttg ttgttaactt gtttattgca gcttataatg    480
gttcaaata aagcaatagc atcacaatt tcacaaataa agcatttttt tcaactgcatt    540
ctagttgtgg tttgtccaaa ctcatcaatg tatcttatca tgtctggatc tgcgactcta    600
gaggatcata atcagccata ccacatttgt agaggtttta cttgctttaa aaaacctccc    660
acacctcccc ctgaacctga aacataaaat gaatgcaatt gttgttgta acttgtttat    720
tgcagcttat aatggttaca aataaagcaa tagcatcaca aatttcacaa ataaagcatt    780
tttttcaact cattctagtt gtggtttgtc caaactcacc aatgtatctt atcatgtctg    840
gatccccatc aagctgatcc ggaaccctta atataacttc gtataatgta tgctatacga    900
agttat                                     906
```

<210> SEQ ID NO 513

<211> LENGTH: 1079

<212> TYPE: DNA

<213> ORGANISM: Artificial Sequence

<220> FEATURE:

<223> OTHER INFORMATION: Description of Artificial Sequence: Synthetic polynucleotide

<400> SEQUENCE: 513

```
caggccctcc gagegtggtg gagccgttct gtgagacagc cgggtacgag tcgtgacgct    60
ggaaggggca agcgggtggt gggcaggaat gcggtccgcc ctgcagcaac cggaggggga    120
```

-continued

gggagaaggg agcggaaaag tctccaccgg acgcggccat ggctcggggg ggggggggca	180
gcgaggagagc gcttccggcc gacgtctcgt cgctgattgg cttcttttcc tcccgcctg	240
tgtgaaaaca caaatggcgt gttttggtg gcgtaaggcg cctgtcagtt aacggcagcc	300
ggagtgcgca gccgccggca gcctcgtct gcccactggg tggggcggga ggtaggtggg	360
gtgaggcgag ctggacgtgc gggcgcggtc ggcctctggc ggggcggggg aggggagggg	420
gggtcagcga aagtagctcg cgcgcgagcg gccgccacc ctccccttcc tctgggggag	480
tcgttttaacc cgccgccggc cgggcctcgt cgtctgattg gctctcgggg ccagaaaaac	540
tggcccttgc cattggctcg tgttcctgca agttgagtcc atccgccggc cagcgggggc	600
ggcgaggagg cgctcccagg ttcggccct ccctcggcc ccgcgccga gagtctggcc	660
gcgcgccct cgcacaactg gcaggaagcg cgcgctgggg gcggggacgg gcagtagggc	720
tgagcggctg cggggcgggg gcaagcacgt ttccgacttg agttgcctca agagggcgct	780
gctgagccag acctccatcg cgcactccgg ggagtggagg gaaggagcga gggctcagtt	840
gggctgtttt ggaggcagga agcacttct cttccaaagt cgctctgagt tgttatcagt	900
aagggagctg cagtggagta ggcggggaga aggcgcacc cttctccgga ggggggaggg	960
gagtgttgca atacctttct gggagttctc tgctgctcc tggtctctga ggaccgccct	1020
gggctggga gaatcccttc ccctcttcc ctctgatct gcaactccag tctttctag	1079

<210> SEQ ID NO 514

<211> LENGTH: 4336

<212> TYPE: DNA

<213> ORGANISM: Artificial Sequence

<220> FEATURE:

<223> OTHER INFORMATION: Description of Artificial Sequence: Synthetic polynucleotide

<400> SEQUENCE: 514

agatgggagg gagtctctg ggcaggctta aaggctaacc tgggtgtgtg gcgttgtcct	60
gcaggggaat tgaacagggtg taaaattgga gggacaagac tcccacaga tttcggttt	120
tgtcgggaag ttttttaata ggggcaata aggaaaatgg gaggataggt agtcatctgg	180
ggttttatgc agcaaaaacta caggttatta ttgcttctga tccgctcgg agtatcttcc	240
atcgaggtag attaaagaca tgctcaccgg agttttatc tctcctgctt gagatcctta	300
ctacagtatg aaattacagt gtcgcgagtt agactatgta agcagaattt taatcatttt	360
taaagagccc agtacttcat atccatttct ccgctcctt ctgcagcctt atcaaaagg	420
attttagaac actcatttta gcccatttt catttattat actggcttat ccaaccocct	480
gacagagcat tggcattttc cctttcctga tcttagaagt ctgatgactc atgaaaccag	540
acagattagt tacatacacc acaaatcgag gctgtagctg gggcctcaac actgcagttc	600
ttttataact ccttagtaca cttttgttg atcctttgcc ttgatcctta attttcagt	660
tctatcacct ctcccgtcag gtgggtgtcc acatttgggc ctattctcag tccagggagt	720
tttacaacaa tagatgtatt gagaatocaa cctaaagctt aactttccac tcccagat	780
gcctctctcc tttttctcca tttataaact gagctattaa ccattaatgg tttccagggt	840
gatgtctcct ccccaatat tacctgatgt atcttacata ttgccaggct gatattttaa	900
gacattaaaa ggtatatttc attattgagc cacatggtat tgattactgc ttactaaaat	960
tttgtcattg tacacatctg taaaagggtg ttccttttgg aatgcaaatg tcaggtgttt	1020

-continued

gttgctcttc ctgacctaaag gtcttctgag cttgtatctt ttctatttaa gcagtgcctt 1080
ctcttggaact ggcttgactc atggcattct acacgttatt gctggctctaa atgtgatttt 1140
gccaagcttc ttcaggacct ataattttgc ttgacttgta gccaaacaca agtaaaatga 1200
ttaagcaaca aatgtatttg tgaagcttgg tttttagggt gttgtgtgtg gtgtgcttgt 1260
gctctataat aatactatcc aggggctgga gaggtggctc ggagtccaag agcacagact 1320
gctcttcag aagtcctgag ttcaattccc agcaaccaca tgggtggctca caaccatctg 1380
taatgggatc tgatgccctc ttctgggtg tctgaagacc acaagtgtat tcacattaaa 1440
taaataaatc ctcttcttc ttctttttt tttttttaa gagaatactg tctccagtag 1500
aatttactga agtaaatgaaa tactttgtgt ttgttccaat atggtagcca ataatacaat 1560
tactctttaa gcactggaaa tgttaccagg gaactaattt ttatttgaag tgtaactgtg 1620
gacagaggag ccataactgc agacttggg gatacagaag accaatgcag actttaatgt 1680
ctttctctt acactaagca ataaagaaat aaaaattgaa cttctagtat cctatttgtt 1740
taaatgcta gctttactta acttttgtgc ttcatctata caaagctgaa agctaagtct 1800
gcagccatta ctaaactga aagcaagtaa tgataattt ggatttcaaa aatgtagggc 1860
cagagttag ccagccagtg gtgggtcctg cctttatgcc tttaatccca gcactctgga 1920
ggcagagaca ggcagatctc tgagtttgag cccagcctgg tctacacatc aagttctatc 1980
taggatagcc aggaatacac acagaaacc tgttggggag gggggctctg agatttcata 2040
aaattataat tgaagcattc cctaattgag cactatggat gtggctaaat ccgtctacct 2100
ttctgatgag atttgggtat tattttttct gtctctgctg ttggttgggt cttttgacac 2160
tgtgggcttt ctttaaagcc tccttcctgc catgtggtct cttgtttgct actaacttcc 2220
catggcttaa atggcatggc tttttgcctt ctaagggcag ctgctgagat ttgcagcctg 2280
atttccaggg tggggttggg aaacttttca aacactaaaa ttgtcctta atttttttt 2340
taaaaaatgg gttatataat aaacctcata aaatagttat gaggagttag gtggactaat 2400
attaatgag tcctccctc ataaaagagc tattaaggct ttttgtctta tacttaactt 2460
tttttttaa tgtggatctc ttagaaccaa gggctctaga gttttagtat acagaaactg 2520
ttgcatcgtc taatcagatt ttctagtctc aaatccagag aatccaaatt ctccacagcc 2580
aaagtcaaat taagaatttc tgacttttaa tggtaatttg cttactgtga atataaaat 2640
gatagctttt cctgaggcag ggtctcacta tgtatctctg cctgatctgc aacaagatat 2700
gtagactaaa gttctgctg cttttgtctc ctgaatacta aggttaaaat gtagtaatac 2760
ttttggaact tgcaggctcag attcctttat aggggacaca ctaagggagc ttgggtgata 2820
gttgtaaat gtgtttaaagt gatgaaaact tgaattatta tcaccgcaac ctacttttta 2880
aaaaaaaaag ccaggcctgt tagagcatgc ttaagggatc ctaggactt gctgagcaca 2940
caagagttag tacttgccag gctcctggtg agagcatatt tcaaaaaaca aggcagacaa 3000
ccaagaaact acagttaaag ttacctgtct ttaaaccatc tgcatatata cagggatatt 3060
aaaatattcc aaataatatt tcattcaagt ttcccccat caaattggga catggatttc 3120
tccggtgaat aggcagagtt ggaactaaa caaatgttg tttgtgatt tgtgaaattg 3180
ttttcaagt atagttaaag cccatgagat acagaacaaa gctgctatct cgaggctctc 3240
tggtttatc tcagaagcac ttctttgggt ttccctgcac tatcctgatc atgtgctagg 3300

-continued

```

cctaccttag gctgattggt gttcaataa acttaagttt cctgtcaggt gatgtcatat 3360
gatttcatat atcaaggcaa aacatgttat atatgttaaa catttgact taatgtgaaa 3420
gttaggtcct tgtgggtttg atttttaatt ttcaaacct gagctaaata agtcattttt 3480
acatgtctta catttggtgg aattgtataa ttgtggtttg caggcaagac tctctgacct 3540
agtaacccta cctatagagc actttgctgg gtcacaagtc taggagtcaa gcatttcacc 3600
ttgaagtga gacgttttgt tagtgtatac tagtttatat gttggaggac atgtttatcc 3660
agaagatatt caggactatt tttgactggg ctaaggaatt gattctgatt agcactgtta 3720
gtgagcattg agtggccttt aggcttgaat tggagtcact tgtatatctc aaataatgct 3780
ggcctttttt aaaagccctt gttctttatc accctgtttt ctacataatt tttgttcaaa 3840
gaaatacttg tttggatctc cttttgacaa caatagcatg ttttcaagcc atattttttt 3900
tccttttttt tttttttttt ggttttttga gacagggttt ctctgtatag ccctggctgt 3960
cctggaactc actttgtaga ccaggctggc ctggaactca gaaatccgcc tgcctctgcc 4020
tcctgagtgc cgggattaaa ggcgtgcacc accacgctg gctaagttgg atattttggt 4080
atataactat aaccaatact aactccactg ggtggatttt taattcagtc agtagctta 4140
agtgtctttt attggccctt cattaatac tactgttcac tctaacagag gctgttggtta 4200
ctagtggcac ttaagcaact tctacggat atactagcag attaagggtc agggatagaa 4260
actagtctag cgttttgtat acctaccagc tttatactac cttgttctga tagaaatatt 4320
tcaggacatc tagctt 4336

```

<210> SEQ ID NO 515

<211> LENGTH: 1846

<212> TYPE: DNA

<213> ORGANISM: Artificial Sequence

<220> FEATURE:

<223> OTHER INFORMATION: Description of Artificial Sequence: Synthetic polynucleotide

<400> SEQUENCE: 515

```

aattctaccg ggtaggggag gcgcttttcc caaggcagtc tggagcatgc gcttttagcag 60
ccccgctggg cacttgccgc tacacaagtg gcctctggcc tcgcacacat tccacatcca 120
ccggtaggcg ccaaccggct ccgttctttg gtggccctt cgcgccacct tctactctc 180
ccctagtcag gaagtcccc cccgccccgc agctcgcgtc gtgcaggacg tgacaaatgg 240
aagtagcacg tctcactagt ctctgtcaga tggacagcac cgctgagcaa tggaaagcggg 300
taggcctttg gggcagcggc caatagcagc tttgtctctt cgctttcttg gctcagaggc 360
tgggaagggg tgggtccggg ggcgggctca ggggcgggct caggggcggg gcgggcgccc 420
gaaggctctc cggaggcccg gcattctgca cgcttcaaaa gcgcacgtct gccgcgctgt 480
tctctcttcc ctcatctccg ggccttttga cctgcaatcg ccgctagcga agttctctatt 540
ctctagaaag tataggaact tcgccaccat gggatcggcc attgaacaag atggattgca 600
cgcaggttct ccggccgctt gggtagagag gctattcggc tatgactggg cacaacagac 660
aatcggctgc tctgatgccg ccgtgttccg gctgtcagcg caggggcgcc cggttctttt 720
tgtcaagacc gacctgtccg gtgccctgaa tgaactgcag gacgagcag cgcggctatc 780
gtggctggcc acgacggggc ttccttgcgc agctgtgctc gacgttctga ctgaagcggg 840

```

-continued

```

aagggactgg ctgctattgg gcgaagtgcc ggggcaggat ctctgtcat ctcaccttgc 900
tcctgccgag aaagtatcca tcatggctga tgcaatgcgg cggctgcata cgcttgatcc 960
ggctacctgc ccattcgacc accaagcgaa acatcgcatc gagcggagcac gtactcggat 1020
ggaagccggc cttgtcgatc aggatgatct ggacgaagag catcaggggc tcgcccagc 1080
cgaactgttc gccaggctca aggcgcgcac gcccgacggc gatgatctcg tcgtgaccca 1140
tggcgatgcc tgcttgccga atatcatggc ggaaaatggc cgctttctg gattcatcga 1200
ctgtggccgg ctgggtgtgg cggaccgcta tcaggacata gcgttgcta cccgtgatat 1260
tgctgaagag cttggcggcg aatgggctga ccgcttcctc gtgctttacg gtatcggcgc 1320
tcccgatcgc cagcgcacgc ccttctatcg ccttcttgac gagttcttct gaggggatcc 1380
gctgtaagtc tgcagaaatt gatgatctat taaacaataa agatgtccac taaaatggaa 1440
gtttttcctg tcatactttg ttaagaaggc tgagaacaga gtacctacat tttgaatgga 1500
aggattggag ctacgggggt gggggtgggg tgggattaga taaatgcctg ctctttactg 1560
aaggctcttt actattgctt tatgataatg tttcatagtt ggatataata atttaacaa 1620
gcaaaaccaa attaagggcc agctcattcc tcccactcat gatctataga tctatagatc 1680
tctcgtggga tcattgtttt tctcttgatt cccactttgt ggttctaagt actgtggttt 1740
ccaaatgtgt cagtttcata gcctgaagaa cgagatcagc agcctctgtt ccacatacac 1800
tcattctca gtattgtttt gccaaagtct aattccatca gaaagc 1846

```

<210> SEQ ID NO 516

<211> LENGTH: 1519

<212> TYPE: DNA

<213> ORGANISM: Artificial Sequence

<220> FEATURE:

<223> OTHER INFORMATION: Description of Artificial Sequence: Synthetic polynucleotide

<400> SEQUENCE: 516

```

taccggtag gggaggcgc tttccaagg cagtctggag catgcgcttt agcagccccg 60
ctgggcactt ggcctacac aagtggcctc tggcctcgca cacattccac atccaccggt 120
aggcgccaac cggtccggt ctttggtggc cccttcgcgc caccttctac tctccccta 180
gtcaggaagt tccccccgc cccgcagctc gcgtcgtgca ggacgtgaca aatggaagta 240
gcacgtctca ctagtctcgt gcagatggac agcaccgctg agcaatggaa gcgggtaggc 300
ctttggggca gcggccaata gcagctttgc tccttcgctt tctgggctca gaggctggga 360
aggggtgggt ccggggcgg gctcaggggc gggctcaggg gcggggcggg cgcccgaagg 420
tcctccggag gcccggcatt ctgcacgctt caaaagcga cgtctgcgc gctgttctcc 480
tcttctcat ctccgggctc ttgcacctgc aggtcctcgc catggatcct gatgatgttg 540
ttgattctc taaatctttt gtgatggaaa actttcttc gtaccacggg actaaactg 600
gttatgtaga ttccattcaa aaaggtatac aaaagccaaa atctggtaca caaggaat 660
atgacgatga ttgaaaggg ttttatagta ccgacaataa atacgacgct gcgggatact 720
ctgtagataa tgaaaaccg ctctctggaa aagctggagg cgtgggtcaa gtgacgtatc 780
caggactgac gaaggttctc gcactaaaag tggataatgc cgaaactatt aagaaagagt 840
taggtttaag tctcactgaa ccgttgatgg agcaagtcgg aacggaagag tttatcaaaa 900
ggttcggtga tgggtctcgc cgtgtagtgc tcagcctcc cttcgtgag gggagtctca 960

```

-continued

```

gcggtgaata tattaataac tgggaacagg cgaaagcggt aagcgtagaa cttgagatta 1020
atthtgaaac ccgtggaaaa cgtggccaag atgcatgata tgagtatatg gctcaagcct 1080
gtgcaggaaa tcgtgtcagg cgatctcttt gtgaaggaac cttacttctg tgggtgtgaca 1140
taattggaca aactacctac agagatttaa agctetaagg taaatataaa atthttaaagt 1200
gtataatgtg ttaactact gattctaatt gtttgtgat tttagattcc aacctatgga 1260
actgatgaat gggagcagtg gtggaatgca gatcctagag ctcgctgac agcctcgact 1320
gtgcttctta gttgccagcc atctgtgtt tgccccccc ccgtgcttc cttgacctg 1380
gaagtgcca ctcccactgt ctttcctaa taaatgagg aaattgcatc gcattgtctg 1440
agtaggtgtc attctattct ggggggtggg gtggggcagg acagcaagg ggaggattgg 1500
gaagacaata gcaggcatg 1519

```

```

<210> SEQ ID NO 517
<211> LENGTH: 23
<212> TYPE: DNA
<213> ORGANISM: Artificial Sequence
<220> FEATURE:
<223> OTHER INFORMATION: Description of Artificial Sequence: Synthetic
primer

```

```

<400> SEQUENCE: 517

```

```

gagggcctat ttcccatgat tcc 23

```

```

<210> SEQ ID NO 518
<211> LENGTH: 22
<212> TYPE: DNA
<213> ORGANISM: Artificial Sequence
<220> FEATURE:
<223> OTHER INFORMATION: Description of Artificial Sequence: Synthetic
oligonucleotide

```

```

<400> SEQUENCE: 518

```

```

cttgtgaaa ggacgaaaca cc 22

```

```

<210> SEQ ID NO 519
<211> LENGTH: 45
<212> TYPE: DNA
<213> ORGANISM: Artificial Sequence
<220> FEATURE:
<223> OTHER INFORMATION: Description of Artificial Sequence: Synthetic
oligonucleotide
<220> FEATURE:
<221> NAME/KEY: modified_base
<222> LOCATION: (4)..(23)
<223> OTHER INFORMATION: a, c, t, g, unknown or other

```

```

<400> SEQUENCE: 519

```

```

aacnnnnnnn nnnnnnnnnn nnggtgttt cgtccttcc acaag 45

```

```

<210> SEQ ID NO 520
<211> LENGTH: 28
<212> TYPE: DNA
<213> ORGANISM: Artificial Sequence
<220> FEATURE:
<223> OTHER INFORMATION: Description of Artificial Sequence: Synthetic
oligonucleotide

```

```

<400> SEQUENCE: 520

```

```

cctgagtgtt gaggccccag tggctgct 28

```

-continued

<210> SEQ ID NO 521
<211> LENGTH: 37
<212> TYPE: DNA
<213> ORGANISM: Artificial Sequence
<220> FEATURE:
<223> OTHER INFORMATION: Description of Artificial Sequence: Synthetic
oligonucleotide

<400> SEQUENCE: 521

acgagggcag agtgctgctt gctgctggcc aggccccc 37

<210> SEQ ID NO 522
<211> LENGTH: 68
<212> TYPE: DNA
<213> ORGANISM: Artificial Sequence
<220> FEATURE:
<223> OTHER INFORMATION: Description of Artificial Sequence: Synthetic
oligonucleotide

<400> SEQUENCE: 522

catcaggctc tcagctcagc ctgagtgttg aggcctgct ggccaggccc ctgctgtggc 60

ccaagctg 68

<210> SEQ ID NO 523
<211> LENGTH: 27
<212> TYPE: DNA
<213> ORGANISM: Artificial Sequence
<220> FEATURE:
<223> OTHER INFORMATION: Description of Artificial Sequence: Synthetic
oligonucleotide

<400> SEQUENCE: 523

gagggcctat ttcccatgat tcttca 27

<210> SEQ ID NO 524
<211> LENGTH: 125
<212> TYPE: DNA
<213> ORGANISM: Artificial Sequence
<220> FEATURE:
<223> OTHER INFORMATION: Description of Artificial Sequence: Synthetic
polynucleotide

<220> FEATURE:
<221> NAME/KEY: modified_base
<222> LOCATION: (84)..(103)
<223> OTHER INFORMATION: a, c, t, g, unknown or other

<400> SEQUENCE: 524

aaaaaaagca ccgactcggg gccacttttt caagttgata acggactagc cttattttaa 60

cttgctatct ctgactctaa aacnnnnnnn nnnnnnnnnn nnnnggtgtt cgctccttcc 120

acaag 125

<210> SEQ ID NO 525
<211> LENGTH: 111
<212> TYPE: DNA
<213> ORGANISM: Artificial Sequence
<220> FEATURE:
<223> OTHER INFORMATION: Description of Artificial Sequence: Synthetic
polynucleotide

<220> FEATURE:
<221> NAME/KEY: modified_base
<222> LOCATION: (9)..(28)
<223> OTHER INFORMATION: a, c, t, g, unknown or other

-continued

<400> SEQUENCE: 525

gaaacaccnn nnnnnnnnnn nnnnnnnngt tttagagcta gaaatagcaa gttaaaataa 60

ggctagtccg ttatcaactt gaaaaagtgg caccgagtcg gtgctttttt t 111

<210> SEQ ID NO 526

<211> LENGTH: 20

<212> TYPE: DNA

<213> ORGANISM: Artificial Sequence

<220> FEATURE:

<223> OTHER INFORMATION: Description of Artificial Sequence: Synthetic oligonucleotide

<400> SEQUENCE: 526

agctgtttta ctggtcggct 20

<210> SEQ ID NO 527

<211> LENGTH: 20

<212> TYPE: DNA

<213> ORGANISM: Artificial Sequence

<220> FEATURE:

<223> OTHER INFORMATION: Description of Artificial Sequence: Synthetic oligonucleotide

<400> SEQUENCE: 527

aatggataca cctggtcgaa 20

<210> SEQ ID NO 528

<211> LENGTH: 20

<212> TYPE: DNA

<213> ORGANISM: Artificial Sequence

<220> FEATURE:

<223> OTHER INFORMATION: Description of Artificial Sequence: Synthetic oligonucleotide

<400> SEQUENCE: 528

caatggatac acctggtcga 20

<210> SEQ ID NO 529

<211> LENGTH: 68

<212> TYPE: DNA

<213> ORGANISM: Homo sapiens

<400> SEQUENCE: 529

accatgtata ccacttgggc tttggcagta gctaactgca ctaaataataa tataaggagg 60

gttttatg 68

<210> SEQ ID NO 530

<211> LENGTH: 23

<212> TYPE: DNA

<213> ORGANISM: Artificial Sequence

<220> FEATURE:

<223> OTHER INFORMATION: Description of Artificial Sequence: Synthetic oligonucleotide

<220> FEATURE:

<221> NAME/KEY: modified_base

<222> LOCATION: (1)..(20)

<223> OTHER INFORMATION: a, c, t or g

<220> FEATURE:

<221> NAME/KEY: modified_base

<222> LOCATION: (21)..(21)

<223> OTHER INFORMATION: a, c, t, g, unknown or other

<400> SEQUENCE: 530

-continued

nnnnnnnnnn nnnnnnnnnn ngg 23

<210> SEQ ID NO 531
<211> LENGTH: 15
<212> TYPE: DNA
<213> ORGANISM: Artificial Sequence
<220> FEATURE:
<223> OTHER INFORMATION: Description of Artificial Sequence: Synthetic
oligonucleotide
<220> FEATURE:
<221> NAME/KEY: modified_base
<222> LOCATION: (1)..(12)
<223> OTHER INFORMATION: a, c, t or g
<220> FEATURE:
<221> NAME/KEY: modified_base
<222> LOCATION: (13)..(13)
<223> OTHER INFORMATION: a, c, t, g, unknown or other

<400> SEQUENCE: 531

nnnnnnnnnn nnnngg 15

<210> SEQ ID NO 532
<211> LENGTH: 23
<212> TYPE: DNA
<213> ORGANISM: Artificial Sequence
<220> FEATURE:
<223> OTHER INFORMATION: Description of Artificial Sequence: Synthetic
oligonucleotide
<220> FEATURE:
<221> NAME/KEY: modified_base
<222> LOCATION: (1)..(20)
<223> OTHER INFORMATION: a, c, t or g
<220> FEATURE:
<221> NAME/KEY: modified_base
<222> LOCATION: (21)..(21)
<223> OTHER INFORMATION: a, c, t, g, unknown or other

<400> SEQUENCE: 532

nnnnnnnnnn nnnnnnnnnn ngg 23

<210> SEQ ID NO 533
<211> LENGTH: 14
<212> TYPE: DNA
<213> ORGANISM: Artificial Sequence
<220> FEATURE:
<223> OTHER INFORMATION: Description of Artificial Sequence: Synthetic
oligonucleotide
<220> FEATURE:
<221> NAME/KEY: modified_base
<222> LOCATION: (1)..(11)
<223> OTHER INFORMATION: a, c, t or g
<220> FEATURE:
<221> NAME/KEY: modified_base
<222> LOCATION: (12)..(12)
<223> OTHER INFORMATION: a, c, t, g, unknown or other

<400> SEQUENCE: 533

nnnnnnnnnn nngg 14

<210> SEQ ID NO 534
<211> LENGTH: 25
<212> TYPE: DNA
<213> ORGANISM: Artificial Sequence
<220> FEATURE:
<223> OTHER INFORMATION: Description of Artificial Sequence: Synthetic
oligonucleotide
<220> FEATURE:
<221> NAME/KEY: modified_base
<222> LOCATION: (1)..(20)

-continued

<223> OTHER INFORMATION: a, c, t or g
<220> FEATURE:
<221> NAME/KEY: modified_base
<222> LOCATION: (21)..(21)
<223> OTHER INFORMATION: a, c, t, g, unknown or other
<220> FEATURE:
<221> NAME/KEY: modified_base
<222> LOCATION: (24)..(24)
<223> OTHER INFORMATION: a, c, t, g, unknown or other

<400> SEQUENCE: 534

nnnnnnnnnn nnnnnnnnnn nggng 25

<210> SEQ ID NO 535
<211> LENGTH: 17
<212> TYPE: DNA
<213> ORGANISM: Artificial Sequence
<220> FEATURE:
<223> OTHER INFORMATION: Description of Artificial Sequence: Synthetic
oligonucleotide
<220> FEATURE:
<221> NAME/KEY: modified_base
<222> LOCATION: (1)..(12)
<223> OTHER INFORMATION: a, c, t or g
<220> FEATURE:
<221> NAME/KEY: modified_base
<222> LOCATION: (13)..(13)
<223> OTHER INFORMATION: a, c, t, g, unknown or other
<220> FEATURE:
<221> NAME/KEY: modified_base
<222> LOCATION: (16)..(16)
<223> OTHER INFORMATION: a, c, t, g, unknown or other

<400> SEQUENCE: 535

nnnnnnnnnn nnggng 17

<210> SEQ ID NO 536
<211> LENGTH: 25
<212> TYPE: DNA
<213> ORGANISM: Artificial Sequence
<220> FEATURE:
<223> OTHER INFORMATION: Description of Artificial Sequence: Synthetic
oligonucleotide
<220> FEATURE:
<221> NAME/KEY: modified_base
<222> LOCATION: (1)..(20)
<223> OTHER INFORMATION: a, c, t or g
<220> FEATURE:
<221> NAME/KEY: modified_base
<222> LOCATION: (21)..(21)
<223> OTHER INFORMATION: a, c, t, g, unknown or other
<220> FEATURE:
<221> NAME/KEY: modified_base
<222> LOCATION: (24)..(24)
<223> OTHER INFORMATION: a, c, t, g, unknown or other

<400> SEQUENCE: 536

nnnnnnnnnn nnnnnnnnnn nggng 25

<210> SEQ ID NO 537
<211> LENGTH: 16
<212> TYPE: DNA
<213> ORGANISM: Artificial Sequence
<220> FEATURE:
<223> OTHER INFORMATION: Description of Artificial Sequence: Synthetic
oligonucleotide
<220> FEATURE:
<221> NAME/KEY: modified_base
<222> LOCATION: (1)..(11)
<223> OTHER INFORMATION: a, c, t or g

-continued

```

<220> FEATURE:
<221> NAME/KEY: modified_base
<222> LOCATION: (12)..(12)
<223> OTHER INFORMATION: a, c, t, g, unknown or other
<220> FEATURE:
<221> NAME/KEY: modified_base
<222> LOCATION: (15)..(15)
<223> OTHER INFORMATION: a, c, t, g, unknown or other

```

```

<400> SEQUENCE: 537

```

```

nnnnnnnnn nnggng

```

16

What is claimed is:

1. An engineered composition comprising:
 - a Cas9 protein; and
 - a guide comprising:
 - (a) an engineered guide sequence capable of hybridizing to a target sequence adjacent to a protospacer adjacent motif,
 - (b) a tracr mate sequence capable of hybridizing to a tracr sequence, and
 - (c) the tracr sequence.
2. An engineered composition comprising one or more vectors comprising one or more nucleotide sequences encoding a Cas9 protein, and one or more nucleotide sequences encoding a guide, the guide comprising:
 - (a) an engineered guide sequence capable of hybridizing to a target sequence adjacent to a protospacer adjacent motif,
 - (b) a tracr mate sequence capable of hybridizing to a tracr sequence, and
 - (c) the tracr sequence.
3. The composition according to claim 1 or 2, wherein the Cas9 protein is translated from mRNA.
4. The composition according to claim 1 or 2, wherein the Cas9 protein is delivered in the form of a protein.
5. The composition according to claim 1 or 2, wherein (a), (b), and (c) are arranged in a 5' to 3' orientation.
6. The composition according to claim 1 or 2, wherein (b) and (c) are fused or covalently linked to one another with intervening nucleotides.
7. The composition according to claim 1 or 2, wherein the Cas9 protein is derived from *Streptococcus* or *Staphylococcus*.
8. The composition according to claim 7, wherein the Cas9 protein is *Streptococcus pyogenes* Cas9.
9. The composition according to claim 1 or 2, further comprising a template.
10. The composition according to claim 1 or 2, wherein the Cas9 protein is linked or fused to one or more NLSs.
11. The composition according to claim 2, wherein the nucleotide sequence encoding the Cas9 protein is codon optimized for expression in a eukaryotic cell.
12. The composition according to claim 6, wherein the tracr sequence comprises at least 40 nucleotides in length.
13. The composition according to claim 1 or 2, wherein the composition is configured as a delivery composition suitable for delivery by an electroporation method.
14. The composition according to claim 1 or 2, wherein two or more different guide sequences are provided for multiplexed targeting.
15. The composition according to claim 1 or 2, wherein the Cas9 protein is linked or fused to at least one functional domain.
16. The composition according to claim 15, wherein the functional domain is a transcriptional activation domain or a transcriptional repression domain.
17. The composition according to claim 1 or 2, wherein the engineered composition comprises or encodes two or more guides each capable of hybridizing to a different target sequence in the eukaryotic cell.
18. The composition according to claim 1 or 2, wherein the engineered composition further comprises a recombination template.
19. The composition of claim 18, wherein the recombination template is inserted by homology-directed repair (HDR).
20. A method of modifying one or more target sequences comprising contacting a cell or population of cells with the composition of claim 1 or 2, wherein the guide sequence directs sequence-specific binding to a target sequence in the cell or population of cells, whereby the target sequence is modified.
21. The method of claim 20, wherein the modification of the one or more target sequences results in:
 - a. a cell or population of cells comprising altered expression levels of one or more gene products;
 - b. a cell or population of cells that produces and/or secretes an endogenous or non-endogenous biological product or chemical compound
22. An engineered cell comprising one or more modified genes modified according to the method of claim 20.
23. The engineered cell of claim 22, wherein the cell produces and/or secretes an endogenous or non-endogenous biological product or chemical compound.
24. The engineered cell of claim 23, wherein the biological product is a protein or an RNA.
25. A cell line comprising the engineered cell of claim 22 and progeny thereof.
26. A plant or animal model comprising the engineered cell of claim 22 and progeny thereof.
27. A composition comprising the engineered cell of claim 22.
28. The composition of claim 27 formulated for use as a therapeutic.
29. A biological product or chemical compound produced by the engineered cell of claim 22.
30. An engineered cell or progeny thereof, the cell being engineered by use of an engineered CRISPR-Cas complex.
31. The cell or progeny thereof of claim 30 that is isolated.

32. The cell or progeny thereof of claim **30** that is further used as a therapeutic.

33. The cell or progeny thereof of claim **30** from which a product is isolated.

34. A product produced by the cell or progeny thereof of claim **30**.

35. The product of claim **34**, wherein the product is a protein or an RNA.

36. The product of claim **35**, wherein the protein comprises a mutation.

37. A pharmaceutical composition for treatment of a disease or disorder, comprising the cell or progeny thereof of claim **30**.

38. The pharmaceutical composition according to claim **37**, wherein the treatment results in genetic changes in one or more cells.

39. The pharmaceutical composition according to claim **37**, wherein the treatment results in correction of one or more defective genotypes.

40. The pharmaceutical composition according to claim **37**, wherein the treatment results in improved phenotype.

41. The cell or progeny thereof of claim **30**, wherein the cell comprises a mutation in a protein expressed from a gene comprising the target sequence.

42. The cell or progeny thereof of claim **41**, wherein the cell comprises deletion of a genomic region comprising the target sequence.

43. The cell or progeny thereof of claim **41**, wherein the cell comprises integration of an exogenous sequence by homology-directed repair.

44. The cell or progeny thereof of claim **41**, wherein the cell comprises decreased transcription of a gene associated with the target sequence.

45. The cell or progeny thereof of claim **41**, wherein the cell comprises increased transcription of a gene associated with the target sequence.

46. The product of claim **34**, wherein the product is a mutated protein or product provided by a template.

* * * * *