



INTERNATIONAL APPLICATION PUBLISHED UNDER THE PATENT COOPERATION TREATY (PCT)

<p>(51) International Patent Classification⁶ : B65D 85/30</p>	<p>A1</p>	<p>(11) International Publication Number: WO 97/03001</p> <p>(43) International Publication Date: 30 January 1997 (30.01.97)</p>
<p>(21) International Application Number: PCT/US96/11296</p> <p>(22) International Filing Date: 3 July 1996 (03.07.96)</p> <p>(30) Priority Data: 08/499,588 7 July 1995 (07.07.95) US</p> <p>(71) Applicant: ASYST TECHNOLOGIES, INC. [US/US]; 48761 Kato Road, Fremont, CA 94538 (US).</p> <p>(72) Inventors: BONORA, Anthony, C.; 300 Felton Drive, Menlo Park, CA 94025 (US). ROSENQUIST, Frederick, T.; 738 Canyon Road, Redwood City, CA 94062 (US). JAIN, Sudhir; 4200 Bay Street #109, Fremont, CA 94538 (US). DAVIS, Mark, R.; Apartment 158, 750 N. Shoreline Boulevard, Mountain View, CA 94043 (US).</p> <p>(74) Agents: MILLER, Mark, E. et al.; Fliesler, Dubb, Meyer & Lovejoy, Suite 400, Four Embarcadero Center, San Francisco, CA 94111-4156 (US).</p>		<p>(81) Designated States: DE, JP, KR, European patent (AT, BE, CH, DE, DK, ES, FI, FR, GB, GR, IE, IT, LU, MC, NL, PT, SE).</p> <p>Published <i>With international search report.</i></p>

(54) Title: SEALABLE, TRANSPORTABLE CONTAINER HAVING A BREATHER ASSEMBLY

(57) Abstract

A transportable, sealable container (18), for example a SMIF pod, including a box (20) and a box door (32). The box (20) has a first sealing surface (91) and the box door (32) has a second sealing surface (93). The two sealing surfaces (91, 93) form a seal when the box door (32) is moved in a sealing position with respect to the box (20). A latch mechanism (118) is provided in the box door (32) for holding the box door in the sealing position. The container further includes a breather assembly having an aperture (110), with a filter (74), that allows gas to flow between the interior of the container (18) and an environment external to the container. A valve (112), which is latched by the latch (118), opens and closes the aperture (110). When the latch (118) unlocks the box door (32), the valve (112) opens the aperture (110). When the door (32) is locked, the valve (112) closes the aperture (110).

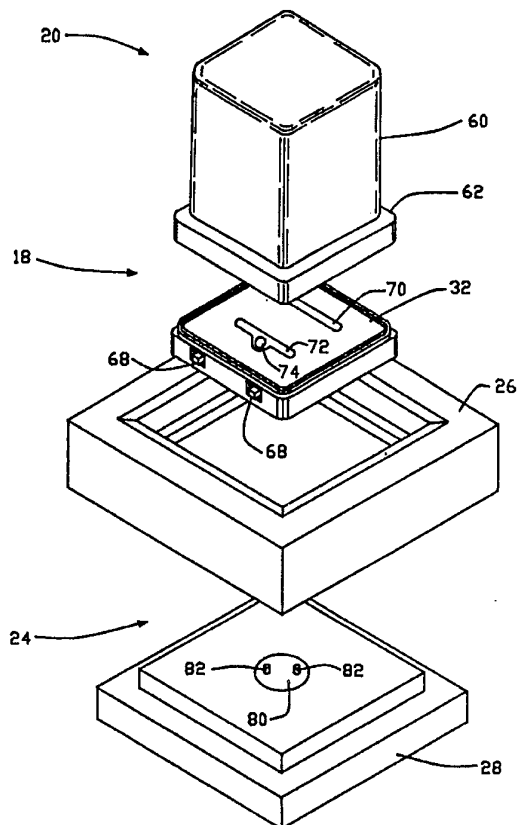

FOR THE PURPOSES OF INFORMATION ONLY

Codes used to identify States party to the PCT on the front pages of pamphlets publishing international applications under the PCT.

AM	Armenia	GB	United Kingdom	MW	Malawi
AT	Austria	GE	Georgia	MX	Mexico
AU	Australia	GN	Guinea	NE	Niger
BB	Barbados	GR	Greece	NL	Netherlands
BE	Belgium	HU	Hungary	NO	Norway
BF	Burkina Faso	IE	Ireland	NZ	New Zealand
BG	Bulgaria	IT	Italy	PL	Poland
BJ	Benin	JP	Japan	PT	Portugal
BR	Brazil	KE	Kenya	RO	Romania
BY	Belarus	KG	Kyrgystan	RU	Russian Federation
CA	Canada	KP	Democratic People's Republic of Korea	SD	Sudan
CF	Central African Republic	KR	Republic of Korea	SE	Sweden
CG	Congo	KZ	Kazakhstan	SG	Singapore
CH	Switzerland	LI	Liechtenstein	SI	Slovenia
CI	Côte d'Ivoire	LK	Sri Lanka	SK	Slovakia
CM	Cameroon	LR	Liberia	SN	Senegal
CN	China	LT	Lithuania	SZ	Swaziland
CS	Czechoslovakia	LU	Luxembourg	TD	Chad
CZ	Czech Republic	LV	Latvia	TG	Togo
DE	Germany	MC	Monaco	TJ	Tajikistan
DK	Denmark	MD	Republic of Moldova	TT	Trinidad and Tobago
EE	Estonia	MG	Madagascar	UA	Ukraine
ES	Spain	ML	Mali	UG	Uganda
FI	Finland	MN	Mongolia	US	United States of America
FR	France	MR	Mauritania	UZ	Uzbekistan
GA	Gabon			VN	Viet Nam

-1-

SEALABLE, TRANSPORTABLE CONTAINER
HAVING A BREATHING ASSEMBLY

CROSS-REFERENCE TO RELATED APPLICATIONS/PATENTS

This Application is related to the following Applications/Patents, all assigned to the assignee of the subject Application:

SEALED STANDARD INTERFACE APPARATUS, U.S. Patent No. 4,674,939;

SEALABLE TRANSPORTABLE CONTAINER HAVING A PARTICLE FILTERING SYSTEM, U.S. Patent No. 4,724,874;

CONTAINER HAVING DISPOSABLE LINERS, U.S. Patent No. 4,739,882;

BOX DOOR ACTUATED RETAINER, U.S. Patent No. 4,815,912;

SEALABLE TRANSPORTABLE CONTAINER HAVING IMPROVED LATCH MECHANISM, U.S. Patent No. 4,995,430;

METHOD AND APPARATUS FOR TRANSFERRING ARTICLES BETWEEN TWO CONTROLLED ENVIRONMENTS, U.S. Patent No. 5,169,272; and

SEALABLE TRANSPORTABLE CONTAINER HAVING IMPROVED LINER, Serial No. 07/865,297, filed April 8, 1992.

-2-

Each of these Applications/Patents is incorporated herein by reference.

5

BACKGROUND OF THE INVENTION

1. Field of the Invention

The present invention relates to transportable containers for standardized mechanical interface systems for reducing particle contamination.

10

2. Description of the Related Art

A standardized mechanical interface (SMIF) system may be used to reduce particle fluxes onto wafers and/or reticles in semiconductor fabrication. This purpose is accomplished, in part, by mechanically ensuring that during transportation and storage the gaseous media (such as air or nitrogen) surrounding the wafers is essentially stationary relative to the wafers and by ensuring that particles from the ambient environment do not enter the immediate wafer environment. The SMIF concept is based on the use of a small volume of controlled (with respect to motion, gas flow direction and external contaminants), particle-free gas to provide a clean environment for articles.

15

A SMIF system has three main components: (1) sealed pods, having a minimal volume, used for storing and transporting cassettes holding reticles or wafers; (2) enclosures placed over cassette ports and wafer processing areas of processing stations so that the environments inside the pods and enclosures (having clean air sources) become miniature clean spaces; and (3) a transfer mechanism to load/unload wafer cassettes from a sealed pod without contamination of the wafers in the wafer cassette from external environments. The sealed pods typically include a box, a box door and a latch for holding the box door in a closed (or sealing) position with respect to the box. The enclosures typically include a port plate, a port door and a latch for holding the port door in a closed (or sealing) position with respect to the port plate. Instead

20

25

30

-3-

5 of a latch, another mechanical apparatus can be used to hold the port door in the closed position.

Wafers are stored and transported in the pods, and are transferred from a pod to a processing station in the following manner. First, a pod is placed on the interface port on top of the enclosure. Then, latches release the box door and the enclosure's port door simultaneously. The box door and the port door are opened simultaneously so that particles which may have been on the external door surfaces are trapped ("sandwiched") between the box and interface port doors. A mechanical elevator lowers the two doors, with the cassette riding on top, into the enclosure covered space. A manipulator picks up the cassette and places it onto the cassette port/elevator or other receiving area of the processing station. After processing, the reverse operation takes place.

Processing stations with enclosures may have an interior region which is a controlled atmosphere; for example, controlled humidity (e.g., dehumidified), nitrogen, argon, or other appropriate gas. In situations where the processing station has a controlled atmosphere, it is desirable to prevent contamination of the controlled atmosphere in the processing station when loading articles from the SMIF pod to the processing station. One mechanism for preventing such contamination is to use a SMIF pod having a particle filtering system as disclosed in U.S. Patent No. 4,724,874, and to control the environment in the interior region of the SMIF pod by the removal or introduction of appropriate gases into the SMIF pod. Thus, a clean room facility using a SMIF pod may wish to inject a gas for example, nitrogen, into the SMIF pod to create an inert environment.

30 In order to maintain the inert environment inside the SMIF pod, the seal between the box and box door of a SMIF pod has been improved to reduce leakage of the gas from inside the SMIF pod. As seal technology improves, the insertion of gas into the pod will require strict monitoring of the pressure inside

-4-

5 the pod in order to ensure that the pressure inside the pod is the same as the
pressure of the interior region of the processing station. A small difference in
pressure between the interior region of the SMIF pod and the interior region of
the processing station can create a vacuum which holds the SMIF pod box door
closed after the latch has been released and the elevator assembly has lowered.
10 In such a case, the elevator would lower the port door, and the pod door would
remain closed preventing access to the interior of the pod.

Additionally, during shipping, a SMIF pod could be placed in the cargo
area of an airplane. When the airplane is at an altitude, there can be an
extreme pressure change. This pressure change could damage the liner of the
15 SMIF pod or force air to leave or enter the SMIF pod through a seal, possibly
damaging that seal.

One solution to these problems is to modify a SMIF pod to add an
aperture with a filter. However, a SMIF pod with only an aperture and filter
would not be able to maintain an inert environment isolated from the
20 environment external to the SMIF pod. Another solution which includes
actively injecting and removing gas through an outlet in the SMIF pod in order
to maintain a desired pressure and clean environment can be expensive and, a
small difference in pressure between the interior of the SMIF pod and the
exterior of the SMIF pod could cause the SMIF pod box door to stick to the
25 SMIF pod box.

SUMMARY OF THE INVENTION

The present invention is directed to overcome the disadvantages of the
prior art.

30 It is, therefore, an object of the present invention to provide a sealable,
transportable container which can equalize the pressure inside the container to
the pressure outside the container without opening the container.

5 Another object of the present invention is to provide a sealable, transportable container having a breather assembly which, upon mating with a SMIF port of a processing station, allows the pressure in the interior of the container to become equal to the pressure inside the port of the processing station.

10 Another object of the present invention is to provide a sealable, transportable container with a breather assembly that can be maintained in an open position during shipping of the container such that pressure changes outside the container will not damage the container.

15 Another object of the present invention is to provide a sealable transportable container capable of maintaining a controlled environment in the interior of the container such that when an attempt is made to open the door of the container, the door will not stick closed because of a vacuum effect within the container.

20 These and other objects of the present invention are provided by a sealable, transportable container (e.g. a SMIF pod) having a breather assembly. The container can be used as part of a SMIF system. The breather assembly has open and closed positions. Closing the breather assembly isolates the interior region of the container from ambient atmospheric conditions. Opening the breather assembly equalizes and/or regulates pressure inside the container,
25 allowing the pressure inside the container to approach the pressure outside the container.

30 In one embodiment, a sealable, transportable container comprises a box having a first sealing surface and an interior region. The container further includes a box door having a second sealing surface so that the first sealing surface and the second sealing surface form a first seal when the box door is moved to a sealing position with respect to the box. The box door has an aperture and a valve for opening and closing the aperture. Connected to the valve is an actuator for moving the valve so that moving the actuator to a first

-6-

5 position closes the aperture and moving the actuator to a second position opens the aperture.

The sealable, transportable container can further include a latch for holding the box door in the sealing position. The actuator can be connected to the latch or the actuator can be the latch. When the latch is in a locked position
10 the box door is held in the sealing position, the valve is closed and the interior region is isolated from the environment external to the container. When the latch is in an unlocked position, the valve is open and gas can flow between the interior region of the container and the environment external to the container. In one embodiment, the latch includes a latch plate and a cam for moving the
15 latch plate.

These and other objects and advantages of the invention will appear more clearly from the following description in which the preferred embodiments of the invention have been set forth in detail in conjunction with drawings.

20 BRIEF DESCRIPTION OF THE DRAWINGS

Figure 1A is an isometric view of a processing station having a canopy for receiving a SMIF pod.

Figure 1B is a cutaway side view of the processing station of Figure 1A.

25 Figure 2 is an exploded isometric view of a SMIF pod in accordance with the present invention.

Figure 3 is an exploded isometric view of a SMIF pod and portions of a port assembly for receiving the SMIF pod.

Figure 4 is a sectional view of a SMIF pod and a port assembly for
30 receiving the SMIF pod.

Figure 5 is a sectional view of the box door showing the breather assembly and the latch mechanism in a locked position.

-7-

5 Figure 6 is a sectional view of the box door showing the breather assembly and the latch mechanism in an unlocked position.

 Figure 7 is a blow-up sectional view of the breather assembly of Figure 6.

 Figures 8A and 9A are plan views of a box door of a SMIF pod showing a latch mechanism and the bottom of the breather assembly in unlocked and locked positions, respectively;

 Figures 8B and 9B are plan views of an alternative embodiment box door of a SMIF pod showing a latch mechanism and the bottom of the breather assembly in unlocked and locked positions, respectively.

15 Figures 10 and 11 are plan views of a two-stage rotary cam of the latch mechanism used to actuate the valve in unlocked and locked positions, respectively.

 Figure 12 is a plan view of the two-stage rotary cam.

 Figure 13 is a side view of the two-stage rotary cam.

20 Figure 14 is a plan view of an interface portion of a SMIF pod box which interacts with the latch mechanism shown in Figures 8-9.

 Figure 15 is a partial cutaway side view of the interface portion shown in Figure 14.

25 DESCRIPTION OF THE PREFERRED EMBODIMENT

 The present invention will be described in the context of a system for storing and transporting semiconductor wafers and/or reticles. However, it is to be understood that a sealable, transportable container in accordance with the present invention may be used to store and transport many other inanimate objects such as magnetic recording disks, as well as living objects such as laboratory animals.

30 One example of a SMIF system is shown in Figs. 1A and 1B, which illustrate a processing station 8 having a canopy 10 which is an easily

-8-

5 removable shield that covers the wafer handling mechanism of processing
equipment 12. Equipment 12 may be, for example, a photoresist applicator,
mask aligner, inspection station or any similar processing equipment. Canopy
10, which is constructed of glass or transparent plastic such as acrylic or lexan
to facilitate visual inspection and/or maintenance within canopy 10, encloses the
10 handling mechanism for processing equipment 12 and a holder 14, such as a
wafer cassette holding wafers 16. The environment within the processing
station is separately maintained and separately cleaned; therefore, equipment 12
need not be installed in a clean room.

 A sealable transportable pod (or container) 18 including a box 20
15 having interior region 21 and a box door 32 is mounted on horizontal surface
22 of a canopy 10 of a port assembly 24. Port assembly 24 includes a port
plate 26, port door 28, and an elevator assembly 30. Elevator assembly 30
transports a cassette 14, containing integrated circuit wafers 16 from interior
region 21 of a box 20 onto the region beneath canopy 10.

20 In Fig. 1B, port door 28 and box door 32 are shown in the closed
position by the dotted lines. The elevator assembly 30 includes a platform 36,
a shaft engagement device 38, and a drive motor 40. Platform 36 carries port
door 28, box door 32 and cassette 14 in a vertical direction. Platform 36 is
attached by engagement devices 38 to a vertical guide 42 of elevator assembly
25 30.

 Typically, guide 42 includes a lead screw (not shown) and drive motor
40 drives a gear (not shown) which engages the lead screw for driving platform
36 up or down. When platform 36 is driven to the closed position, port door
28 closes the port opening in canopy 10.

30 In a similar manner, a manipulator assembly shown generally by
numeral 44 includes a platform 46 which has an engagement means 48 for
engaging vertical guide 42. Manipulator assembly 44 includes a manipulator
arm 50 and engagement head 52 adapted to engage cassette 14. By vertical

5 operation of platforms 36 and 46, and by operation of manipulator assembly 44, cassette 14 is moved from its position on box door 32 to a position on equipment station 13 (as shown by the broken lines).

With reference to Fig. 2, box 20 includes a domed housing 60 and a ring-like engaging portion 62. Housing 60 and engaging portion 62 may be formed integrally, for example, by injection molding, or as separate components assembled to form box 20. A gasket 64, which provides the seal between box 20 and box door 32 resides in a gasket-retaining slot 66 in box door 32. In the preferred embodiment, a liner (not shown) is provided on door 32 and gasket 64 contacts the liner. The liner is a removable element which may be formed of, for example, plastic materials which do not outgas or introduce particles, as described in U.S. Patent No. 4,739,882, which is hereby incorporated by reference. The liner may also be formed of a material which provides the capability of dissipating or preventing the formation of static charges. A latch mechanism is housed in box door 32 and protrudes from box door 32 through windows 68 to engage latch engaging surfaces 150₁₋₈ (Figs. 2 and 14-15) of box 20. On the top surface of box door 32 are cassette guides 70 and 72, which are used to position cassette 14 (Fig. 1B) on box door 32. Shown on cassette guide 72 is filter 74 which, as described below, is part of the breather assembly. Filter 74 and the aperture it covers are not required to be located on a cassette guide.

Fig. 3 is an exploded view of container 18 and port assembly 24. Port door 28 has an actuating mechanism 80 with pins 82. Pins 82 fit inside holes in a cam mechanism 116 (described below). Actuating mechanism 80 rotates, thus, actuating cam 116 which translates the motion to a latch (described below) and a valve in the breather assembly (described below). Such motion translated to the latch releases the box door 32 from box 20, allowing the wafers to be removed.

-10-

5 Fig. 4 shows container 18 mated to port assembly 24 of processing
equipment 12. Container 18 is designed for sealably mating with the port
assembly 24. Box 20 has first and second box top sealing surfaces 91 and 92,
respectively. Box door 32 has a first box door sealing surface 93 for forming
a first seal (sealably mating) with first box top sealing surface 91 when gasket
10 64 is compressed. Port plate 26 has first and second port plate sealing surfaces
95 and 96, respectively. First port plate sealing surface 95 sealably mates with
second box top sealing surface 92, forming a second seal with gasket 102.

 Port door 28 has a first port door sealing surface 97 which sealably
mates with second port plate sealing surface 96 forming a third seal with gasket
15 104. Port door 28 has a second port door sealing surface 94 which sealably
mates with second box door sealing surface 98 to form a fourth seal.

 Figs. 5-7 show the preferred embodiment breather assembly housed
within box door 32. On top of cassette guide 72 is a filter 74 covering an
aperture 110. Beneath aperture 110 is a valve 112 which serves to open and
20 close aperture 110. Valve 112 is normally held in a closed position (Fig. 5) by
springs 114. Springs 114 allow valve 112 to be pivoted so that aperture 110
can be opened (Fig. 6); however, when the pivoting force is removed from
valve 112, springs 114 force valve 112 to close aperture 110. The force that
opens valve 112 is provided by latch plate 118 (or other actuator) which is
25 controlled by cam 116 (described below). When latch plate 118 is in the locked
position (Fig. 5), latch plate 118 does not exert a force on valve 112. When
latch plate 118 is in the unlocked position (Fig. 6), latch plate 118 pushes
against valve 112 causing valve 112 to pivot.

 During the normal operation of a SMIF system, a container is placed
30 on a port. The port unlocks the latch which causes valve 112 to open aperture
110 and allow gas to flow between the interior region of the container 21 and
the interior region of the port.

-11-

5 The pivoting of valve 112 opens aperture 110 such that when the
pressure inside container 20 is greater than the pressure external to container
20 air passes from interior region 21 of container 18 through filter 74, through
aperture 110, through box door upper aperture 126 (see Fig. 7), through latch
plate aperture 127 (see Fig. 7), and through box door lower aperture 128. If
10 the container is mated to a port, gas exiting lower aperture 128 would flow into
the interior region of the port. Should the pressure in container 20 be less than
the pressure outside box door 32, then air or other gases would travel in a path
reverse to that described above. Various alternatives are available that route the
air through other paths; for example, the air can circulate within box door 32
15 and exit out apertures in the side of box door 32, air can travel through a
conduit or air can be channeled to an outlet in a manner similar to that
described in U.S. Patent No. 5,169,272, incorporated herein by reference. The
discussion of the flow of gas also includes the flow of liquids.

Filter 74 can be used to prevent contaminants from entering container
20 20 or from leaving container 20. The preferred embodiment filter is a
continuous membrane of expanded polytetrafluoroethylene (PTFE) laminated to
a 100% polyester spun bonded non-woven backer. Alternative materials to
PTFE are polypropylene (PP), cellulose acetate, cellulose nitrate, UHMW
polyethylene, high density polyethylene (HDPE), low density polyethylene
25 (LDPE), very low density polyethylene (VLDPE), polyvinylidene fluoride
(PVDF), polysulfone (PSO), ethylene vinyl acetate (EVA), polystyrene (PS),
PFA, and nylon 66. Alternatives for the backer are polyester, polycarbonate,
polypropylene, acetate, acrylar, kimdura, polystyrene, primalyn UPHC, Tyvek,
vinyl and aluminum foil. Alternatives for an adhesive are pressure sensitive
30 acrylic adhesive no. 200, rubber or repositionable wet surface acrylic.
Additionally, any other filters known in the art could be used or filters known
in other arts can be used, for example, a high efficiency disk drive breather
filter, syringe filter, gas filter, submicron filters with electropolished and

-12-

5 welded 316SS housings, pleated media filters, cartridge filters, and in-line filters.

The preferred embodiment valve would be made of polycarbonate. The latch plate would preferably be made of aluminum. In the preferred embodiment, valve 112 would fit entirely within box door 32 (e.g., not stick
10 out the bottom of box door 32) so that an operator is not likely to accidentally open valve 112. Furthermore, the breather assembly-latch mechanism is designed so that upon unlocking box door 32, the pressure in interior region 21 of box 20 is equalized very quickly to the pressure in the processing station so that box door 32 does not remain closed because of a vacuum effect.

15 In one alternative, it would be possible to fit a plug into box door aperture 128 to force valve 112 to remain in the opened position. This plug could have a hole in it so that while valve 112 is in an open position, air could flow between interior region 21 and an external environment. This embodiment could be used for containers shipped by airplane. Other alternatives include
20 actuating the valve separately from the latch plate or separately from the latch, and even placing the breather assembly directly on box 20. Filter 74 could also be used as part of a liner. When the filter is used in conjunction with the liner, the filter could be part of the liner, the filter could be the liner, the filter could be below the liner or the filter could be above the liner. Alternatively, there
25 can be a breather assembly with no filter. In yet another embodiment, the breather assembly can be manually operated, or automatically operated in some other fashion.

As stated above, cam 116 and latch plate 118 control movement of valve 112. Figs. 8-15 further explain the cam and latch mechanisms. The two-
30 stage rotary cam latch mechanism of the present invention (preferred embodiment depicted in Figs. 8A and 9A) includes latch plates 118, a cam mechanism 116 pivotally mounted on box door 32, and latch plate supports 135₁₋₆. The operation of latch mechanism is a two-stage operation. In the first

-13-

5 stage of operation during locking, cam mechanism 116 rotates causing latch plates 118 to slide linearly. In the second stage, cam mechanism 116 rotates causing latch plates 118 to pivot on latch plate supports 135₁₋₆. The breather assembly of the present invention can be used with a one stage cam or other type of cam.

10 Each latch plate 118 has at least one box-engaging portion. In the preferred embodiment of the present invention, each of the two latch plates 118 has two latch arms 142, 144 and 146, 148, respectively. Each latch arm has two latch fingers 142₁₋₂, 144₁₋₂, 146₁₋₂, and 148₁₋₂ which engage respective ones of latch engaging surfaces 150₁₋₈ of box 20 (see Figure 14).

15 The first stage of the latching operation involves moving latch plates 118 from the retracted (or disengaged or unlocked) position (Fig. 8A) where latch plates 118 are entirely contained within box door 32 to the extended (or engaging or locked) position (Fig. 9A) where latch fingers 142₁₋₂, 144₁₋₂, 146₁₋₂ and 148₁₋₂ extend out of box door 32 and are adjacent to latch engaging surfaces 150₁₋₈ of box 20. In the first stage when latch plates 118 move from the retracted position to the extended position in a plane parallel to the plane of box door 32, latch fingers do not contact latch engaging surfaces 150₁₋₈. Accordingly, there are no particles created by scraping or rubbing of the latch fingers against latch engaging surfaces 150₁₋₈.

25 The second stage of the latching operation involves substantially vertical motion of latch fingers 142₁₋₂, 144₁₋₂, 146₁₋₂ and 148₁₋₂. "Substantially vertical motion" refers to motion in a direction perpendicular to the plane of box door 32, and to the plane of motion of latch plates 118 during the first stage of the latching operation. The motion of latch fingers 142₁₋₂, 144₁₋₂, 146₁₋₂ and 148₁₋₂ during the second stage engages latch fingers 142₁₋₂, 144₁₋₂, 146₁₋₂ and 148₁₋₂ with respective ones of latch engaging surfaces 150₁₋₈, and creates a latching and/or clamping force which sealably mates first sealing surface 91 of box 20 with second sealing surface 93 of box door 32.

-14-

5 Looking at Figs. 8A and 9A, the bottom of valve 112 and aperture 127 can be seen. When the latch mechanism is in the unlocked position (Fig. 8A) the latch plate 118, at the edge of aperture 127, is exerting a force on valve 112 causing valve 112 to pivot. Thus, the bottom of valve 112 appears on an angle. This situation is analogous to the drawing of Fig. 6.

10 When the latch mechanism is in the locked position (Fig. 9A), latch plates 118 are positioned such that the latch plates 118 are not providing any force on valve 112 and thus springs 114 hold valve 112 in a closed position. This situation is analogous to the drawing of Fig. 5.

15 An alternative embodiment is shown in Figs. 8B and 9B. Rather than have an aperture in latch plate 118B, the edge of latch plates 118B exerts a force on valve 112B. Thus, some of the gas may be deflected by the latch plate and thus circulate through cavity 154B. Fig. 8B shows the alternative embodiment in the unlocked position and, Fig. 9B shows the alternative embodiment in a locked position.

20 In operation, both embodiments work fairly similar. When the latch plates are in an unlocked position a force is exerted on valve 112, opening aperture 110. When the latch plates are in a locked position, the latch does not exert a force on valve 112, and aperture 110 is closed.

25 The details of the construction and operation of the preferred embodiment cam mechanism 116 will be described with reference to Figs. 5, 6, 10-13. Figure 10 can be correlated with Figure 8A. Figure 11 can be correlated with Figure 9A.

30 Cam mechanism 116 is a two-stage cam mounted on a pivot post 160 (Figs. 5, 6 and 13). Pivot post 160 is attached to box door 32. First and second holes 162 and 164 (Fig. 13) in cam mechanism 116 engage pins 82 and 83 of actuating mechanism 80 (Fig. 3).

 The two stages of operation of cam mechanism 116 and latch plates 118 occur as follows. In the first stage of the latching operation, cam lobes 170 and

-15-

5 172 engage surfaces 174 and 176 (Figs. 10-11), respectively of latch plates 118. As cam mechanism 116 rotates through an angle of approximately 40° from an unlatched to an intermediate position, cam lobes 170 and 172 cause latch plates 116 to move from the retracted to the extended position. In order to maintain latch plates 116 in a plane parallel to the plane of box door 32 during the sliding operation of the first stage of the latching operation, latch springs (not shown) can be attached to latch plates 116. When latch plates 118 are in the extended position, valve 112 is in the closed position such that aperture 110 is closed.

15 Risers 180 and 182 (Figs. 5, 6, 12 and 13) are provided on roller surface 184 of cam mechanism 116. As cam mechanism 116 rotates beyond the first 40° of motion from the intermediate position to a latched position, linear motion of latch plates 118 ceases and rollers 190 and 192 begin riding up respective ones of risers 180 and 182. As rollers 190 and 192 ride up risers 180 and 182, latch plates 118 pivot about an axis defined by the contact points of latch plates 118 and latch plate supports 135₁₋₆. The pivoting motion of latch plates 118 causes latch fingers 142₁₋₂, 144₁₋₂, 146₁₋₂, and 148₁₋₂ to move substantially vertically without scraping against fingers latch surfaces 150₁₋₈. Experimental results have shown that latch fingers 142₁₋₂, 144₁₋₂, 146₁₋₂ and 148₁₋₂ undergo horizontal motion of only approximately 0.001". This minimal amount of horizontal motion minimizes the generation of particles by scraping.

25 In the unlatching, operation rollers 190 and 192 ride back down risers 180 and 182 as cam mechanism 116 is rotated in the opposite direction. Springs (not shown) provide the biasing force to keep rollers 190 and 192 in contact with risers 180 and 182. After rollers 190 and 192 come in contact with roller surface 184, cam lobes 170 and 172 engage cam surfaces 174 and 176 of latch plates 118 and move latch plates 118 from the extended position to the retracted position (Fig. 10). Rollers can also be replaced with a slide mechanism, plastic bump or some other self lubricated material.

-16-

5 When latch plates 118 and cam mechanism 116 are in the latched position (Fig. 11), cam lobes 170 and 172 are aligned with the axis of rotation of cam mechanism 116. Accordingly, any force tending to move latch plates 118 from the extended to the retracted position is transmitted along cam lobes 170 and 172 through the rotational axis of cam mechanism 116 without creating
10 any torque which would rotate cam mechanism 116 from the latched position. Thus, cam lobes 170 and 172 physically maintain latch plates 118 in the extended position both during the second stage of the latching operation and when the latch mechanism is in the latched orientation, preventing the latch from releasing under the application of linear impacts.

15 The second stage of the latching operation provides a strong clamping force to retain box door 32 in a sealing position with respect to box 20. This seal allows interior region 21 to be evacuated and back-filled with an inert gas. The clamping force is approximately one (1) pound per linear inch. This clamping force is regulated by a slight bowing or spring action of latch plates
20 118. This bowing is designed into latch plates 118 which are formed of 0.125-inch thick aluminum alloy, for example, 7075-T6. Although the clamping force is useful to maintain a strong seal, the breather assembly will still function in an alternate embodiment where the latch plates move horizontally but not vertically.

25 In order to prevent localized bending or deflection of box door 32, due to the application of the clamping force, the clamping loads are distributed. One aspect to the distribution of the clamping force is the use of multiple latch arms for each latch plate. Latch arms 142, 144, 146 and 148 are positioned at points which are half the distance from the center to the end of the edge of the
30 box door. For a box door having a width W , latch arms are a distance approximately $W/2$ from each other and a distance approximately $W/4$ from the edge of the box door.

-17-

5 To strengthen the latch engaging areas of box 20, which can be formed
of plastic, posts 200 are provided between each pair of latch engaging surfaces
150₁₋₈ (Figs. 14-15). To accommodate posts 200, each latch arm 142, 144, 146
and 148 has latch fingers 142₁₋₂, 144₁₋₂, 146₁₋₂ and 148₁₋₈ separated by a notch.
Posts 200 serve to decrease the unsupported length of latch engaging surfaces
10 150₁₋₈ by a factor of approximately one third and to increase the shear area by
a factor of 2.

 The entire latch mechanism and breather assembly is contained in box
door 32 which facilitates cleaning of box 20. Tampering with latch mechanism
80 is virtually eliminated due to the fact that outside forces intended to move
15 latch plates 118 from the extended to the retracted position do not rotate cam
mechanism 116, and cam mechanism 116 is contained within cavity 154 of box
door 32. Unauthorized access would require rotating cam mechanism 116 by
inserting an implement into cam holes 162 and 164. Accordingly, access can
be limited by the use of an interlock system which must be activated, and/or
20 mechanical keys which must be inserted before rotation of cam mechanism 116
is possible.

 Further information about the cam and latch mechanisms can be found
in U.S. Patent No. 4,995,430, which is incorporated by reference. The use of
the breather assembly is not limited to use in conjunction with the disclosed
25 latch. One skilled in the art could use the breather assembly with various other
actuating devices. For example, the breather assembly could be used with
another type of latch or another type of locking device. The breather assembly
could be actuated directly by pins 82, a vacuum port on the port door or by a
magnetic actuator (e.g. using Hall effect) on the port.

30 The foregoing description of a preferred embodiment of the invention
has been presented for purposes of illustration and description. It is not
intended to be exhaustive or to limit the invention to the precise form disclosed,
and obviously many modifications and variations are possible in light of the

-18-

5 above teaching. The preferred embodiment was chosen and described in order
to best explain the principles of the invention and its practical application to
thereby enable others skilled in the art to best utilize the invention in various
embodiments and with various modifications as are suited to particular use
contemplated. It is intended that the scope of the invention be defined by the
10 claims appended hereto.

CLAIMS

What is claimed is:

- 1 1. A sealable, transportable container, comprising:
2 a box having a first sealing surface and an interior region;
3 a box door having a second sealing surface adapted to form a seal with
4 said first sealing surface when said box door is moved to a sealing position with
5 respect to said box;
6 a latch having a locked position and an unlocked position, said latch
7 adapted to hold said box door in said sealing position when said latch is in said
8 locked position;
9 a breather assembly, actuated by said latch mechanism so that said
10 breather assembly allows gas to flow between the interior region and an
11 environment external to said container when said latch is in the unlocked
12 position.

- 1 2. A sealable, transportable container according to claim 1, wherein
2 said breather assembly does not allow gas to flow between said interior region
3 and said external environment when said latch is in the locked position.

- 1 3. A sealable, transportable container according to claim 1, wherein
2 said breather assembly is integrated with said box door.

- 1 4. A sealable, transportable container according to claim 1, wherein
2 said breather assembly includes:
3 a filter for preventing contaminants from entering the interior region;
4 and
5 a valve which moves between open and closed positions.

-20-

1 5. A sealable, transportable container according to claim 4, wherein
2 said latch activates said valve so that unlocking said latch opens said valve.

1 6. A sealable, transportable container according to claim 1, wherein
2 said box door has an aperture allowing gas to flow between said interior
3 region and the environment exterior to said container;

4 said breather assembly includes a valve for opening and closing the
5 aperture; and

6 said latch actuates said valve so that said valve opens said aperture
7 when said latch is in the unlocked position and said valve closes said aperture
8 when said latch is in the locked position.

1 7. A sealable, transportable container according to claim 1, wherein:
2 said latch includes a plate movable between first and second positions
3 and adapted to engage said box when in the first position; and

4 said breather assembly includes a valve having open and close positions;
5 and

6 said valve is actuated by said movable plate so that moving said plate
7 to the second position applies a force to said valve so that said valve moves to
8 the open position.

1 8. A sealable, transportable container, comprising:

2 a box having a first sealing surface and an interior region;

3 a box door having a second sealing surface adapted to form a seal with
4 said first sealing surface when said box door is moved to a sealing position with
5 respect to said box;

6 a latch having a locked position and an unlocked position, said latch
7 holds said box door in the sealing position when said latch is in the locked
8 position;

-21-

9 breather means, responsive to said latch, for equalizing a pressure in
10 said interior region with a pressure in an environment external to said container.

1 9. A sealable, transportable container according to claim 8, wherein
2 said breather means includes a path for gas to travel between said
3 interior region and said external environment; and
4 said breather means opens said path when said latch is in said locked
5 position.

1 10. A sealable, transportable container according to claim 8, wherein
2 said latch includes a plate movable between locked and unlocked
3 positions and adapted to engage said box when in the locked position; and
4 said breather means includes a valve for opening and closing said
5 breather means, said valve actuated by said movable plate so that moving said
6 plate to the unlocked position applies a force to said valve so that said valve
7 moves to the open position.

1 11. A door for a sealable, transportable container, said door having an
2 aperture, comprising:
3 a latch for retaining said door in a closed position with respect to said
4 container; and
5 a valve, actuated by said latch, for opening and closing said aperture.

1 12. A door according to claim 11, further including a filter covering
2 said aperture.

1 13. A door according to claim 11, wherein said door is adapted to
2 mate with a port door of a Standard Mechanical Interface (SMIF) system.

-22-

1 14. A sealable, transportable container for use in a Standard
2 Mechanical Interface (SMIF) system, said container comprising:
3 a box having a first sealing surface and an interior region;
4 a box door having a second sealing surface adapted to form a seal with
5 said first sealing surface when said box door is moved to a sealing position with
6 respect to said box, said box door having an aperture;
7 a latch having a locked position and an unlocked position so that said
8 box door is retained in the sealing position when said latch is in the locked
9 position;
10 a valve, adapted to open and close said aperture, said valve activated
11 by said latch so that when said latch is in said unlocked position said valve
12 opens said aperture.

1 15. A sealable, transportable container according to claim 14, wherein
2 said latch includes a plate movable between locked and unlocked
3 positions so that said plate is in contact with said box when said plate is in said
4 locked position and said plate applies a force to said valve causing said valve
5 to open said aperture when said plate is in the unlocked position,.

1 16. A sealable, transportable container according to claim 15, further
2 including a spring adapted to hold said valve in the closed position when said
3 plate does not apply a force to said valve.

1 17. A system for maintaining the cleanliness of
2 an article to be processed, comprising:
3 a container comprising:
4 a box having a first sealing surface, a second sealing surface and
5 an interior region;

-23-

6 a box door having a third sealing surface so that said first
7 sealing surface and said third sealing surface form a first seal when said box
8 door is moved to a sealing position with respect to said box,

9 a latch having a locked position and an unlocked position so that
10 said box door is retained in the sealing position when said latch is in the locked
11 position and said box door can be removed from the sealing position when said
12 latch is in the unlocked position, and

13 a breather assembly, actuated by said latch, said breather
14 assembly having open and closed positions so that said breather assembly is
15 closed and said interior region is isolated from an environment external to said
16 container when said latch is in the locked position, and said breather is open
17 and gas can flow between the interior region and the environment external to
18 said container when said latch is in the unlocked position; and

19 a port comprising:

20 a port plate having a fourth sealing surface and a fifth sealing
21 surface, said fourth sealing surface and said second sealing surface forming a
22 second seal when said box is moved to a sealing position with respect to said
23 port plate, and

24 a port door having a sixth sealing surface so that said fifth
25 sealing surface and said sixth sealing surface form a third seal when said port
door is moved to a sealing position with respect to said port plate.

1 18. A system according to claim 17, wherein said port further includes
2 an actuating mechanism adapted to lock and unlock said latch.

1 19. A system according to claim 17, wherein
2 said box door has an aperture allowing gas to flow between the interior
3 region and the environment external to said container; and

-24-

4 said breather assembly includes a valve for opening and closing the
5 aperture, said valve actuated by said latch so that said valve closes the aperture
6 when said latch is in the locked position and said valve opens the aperture when
7 said latch is in the unlocked position.

1 20. A system according to claim 19, wherein said breather assembly
2 further includes a filter for filtering air passing through the aperture.

1 21. A system according to claim 17, wherein
2 said latch includes
3 a movable plate, having locked and unlocked positions, for
4 engaging said box, and
5 a cam for moving said movable plate;
6 said breather assembly includes a valve for opening and closing said
7 breather assembly, said valve actuated by said movable plate so that moving
8 said plate to the unlocked position applies a force to said valve so that said
9 valve opens said breather assembly; and
10 said port includes means for actuating said cam.

1 22. A transportable container, comprising:
2 a box having a first mating surface and an interior region;
3 a box door having a second mating surface adapted to mate with said
4 first mating surface when said box door moved to a storage position;
5 a breather assembly having an air passage between said interior region
6 and an environment external to said container, said breather assembly including
7 a valve, said valve having an open position that opens said air passage and a
8 closed position that closes said air passage;
9 an actuator adapted to actuate said valve between said open and closed
10 positions.

-25-

1 A transportable container according to claim 22, where said breather
2 assembly is located in said box door.

1 23. A transportable container according to claim 23, where said
2 actuator is located in said box door.

1 24. A transportable container according to claim 24, wherein said
2 actuator is a latch having locked and unlocked positions, said latch being
3 adapted to hold said box door in said storage position when said latch is in said
4 locked position.

2/12

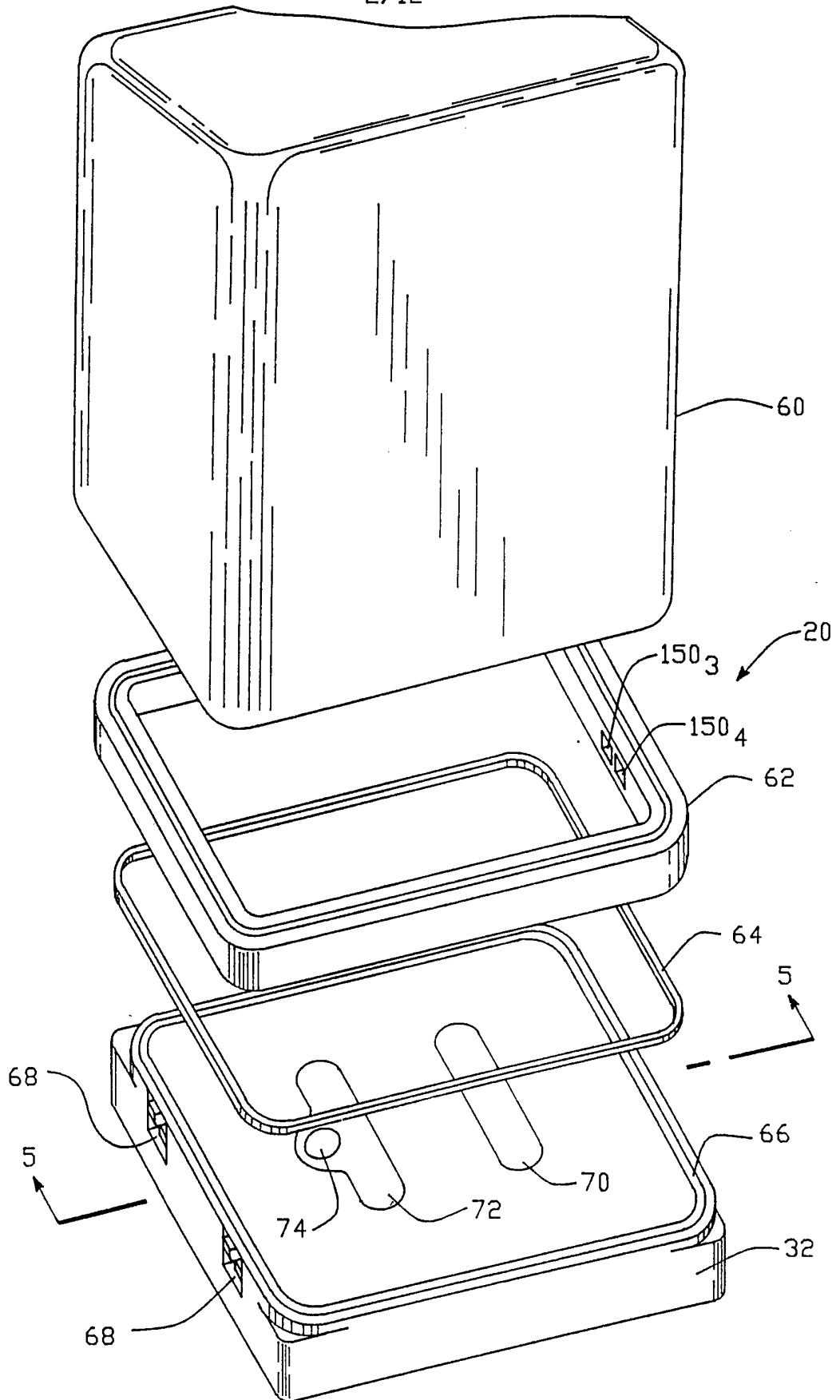

FIG. -2
SUBSTITUTE SHEET (RULE 26)

3/12

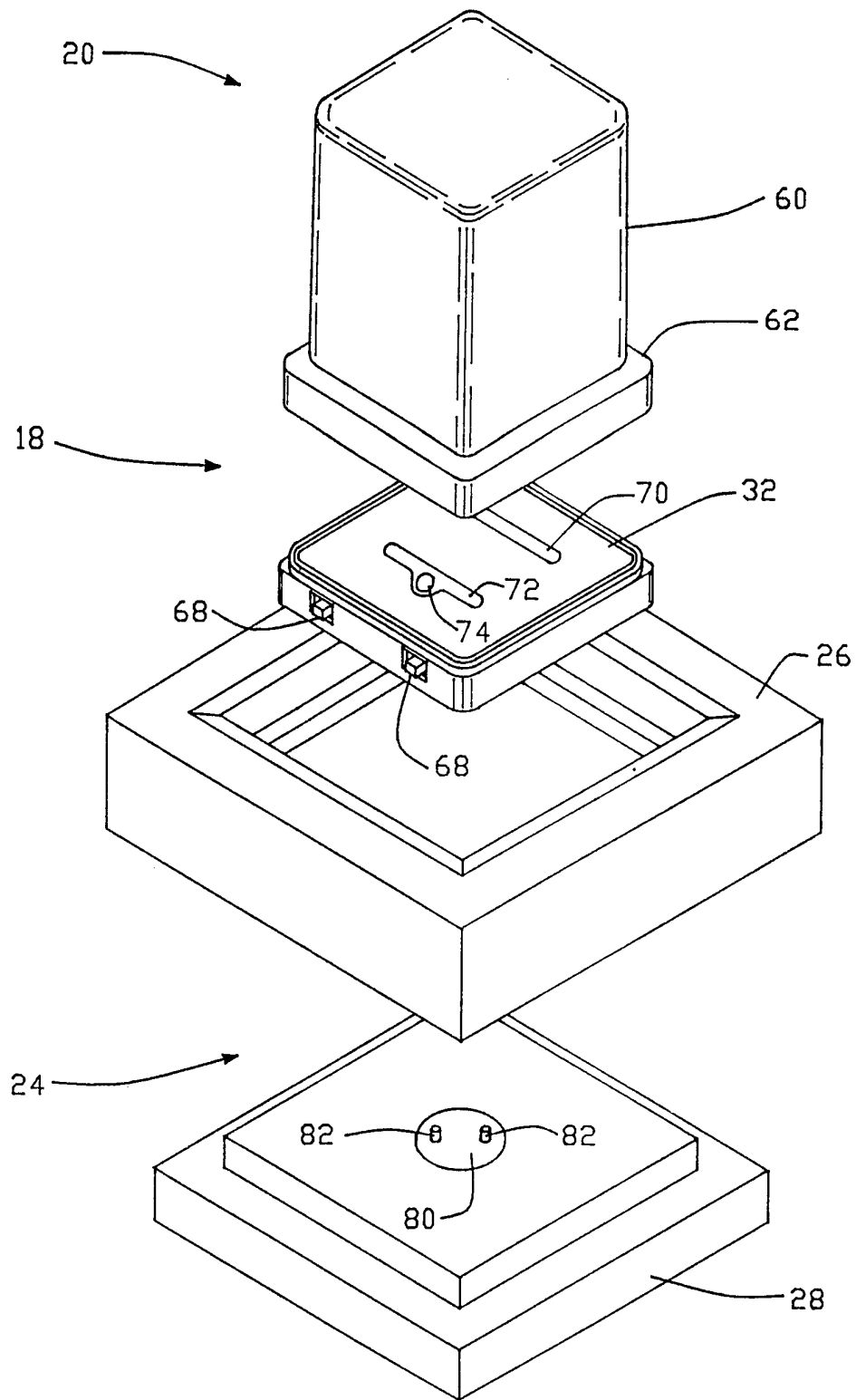

FIG. -3

SUBSTITUTE SHEET (RULE 26)

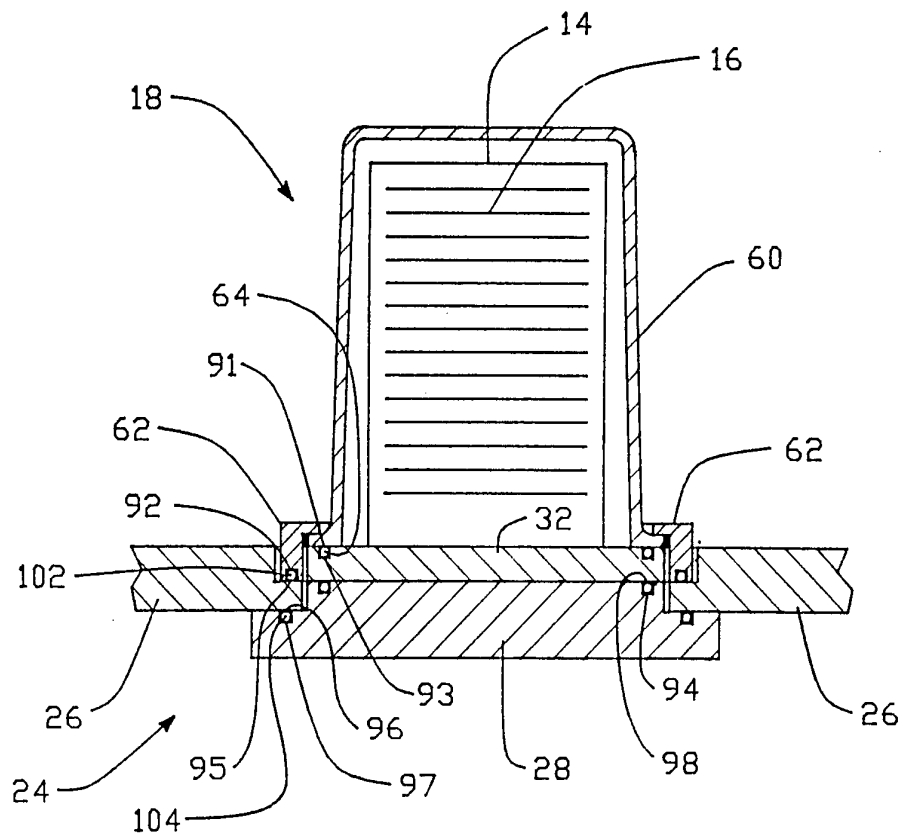

FIG. - 4

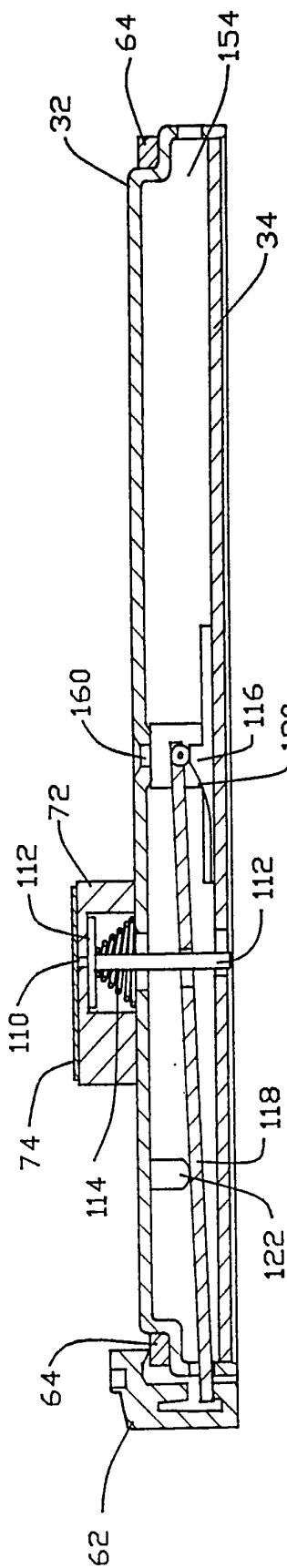

FIG. -5

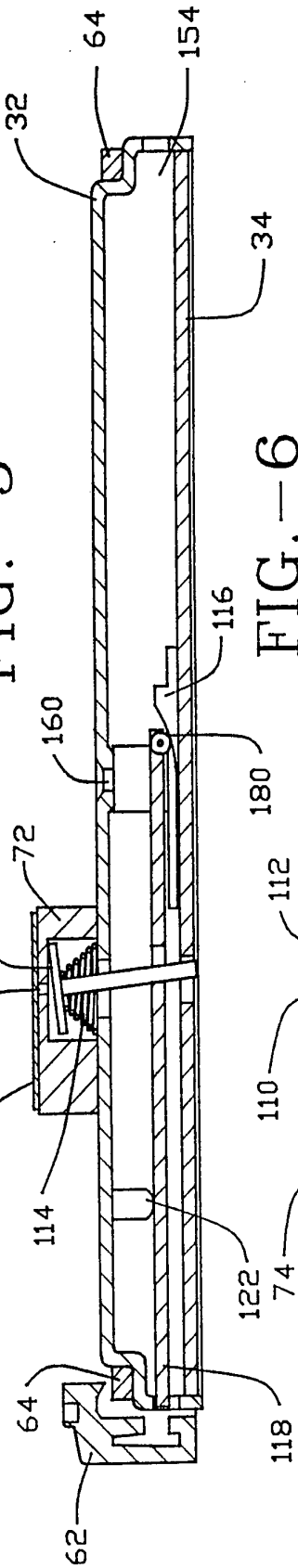

FIG. -6

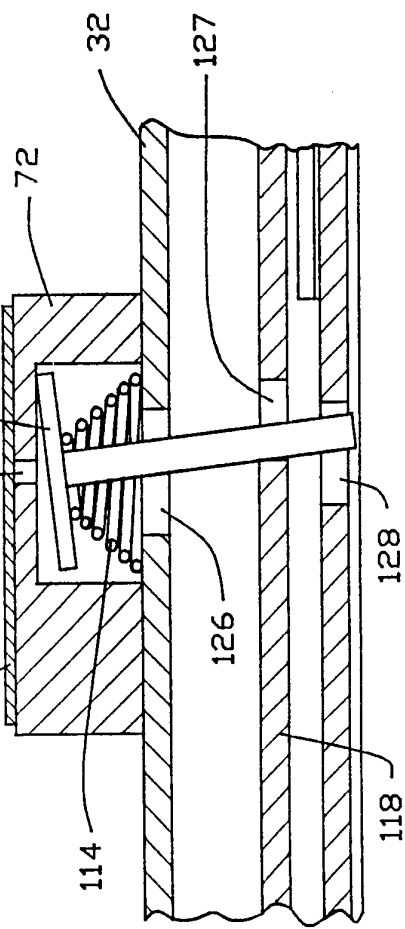

FIG. -7

FIG. -8A

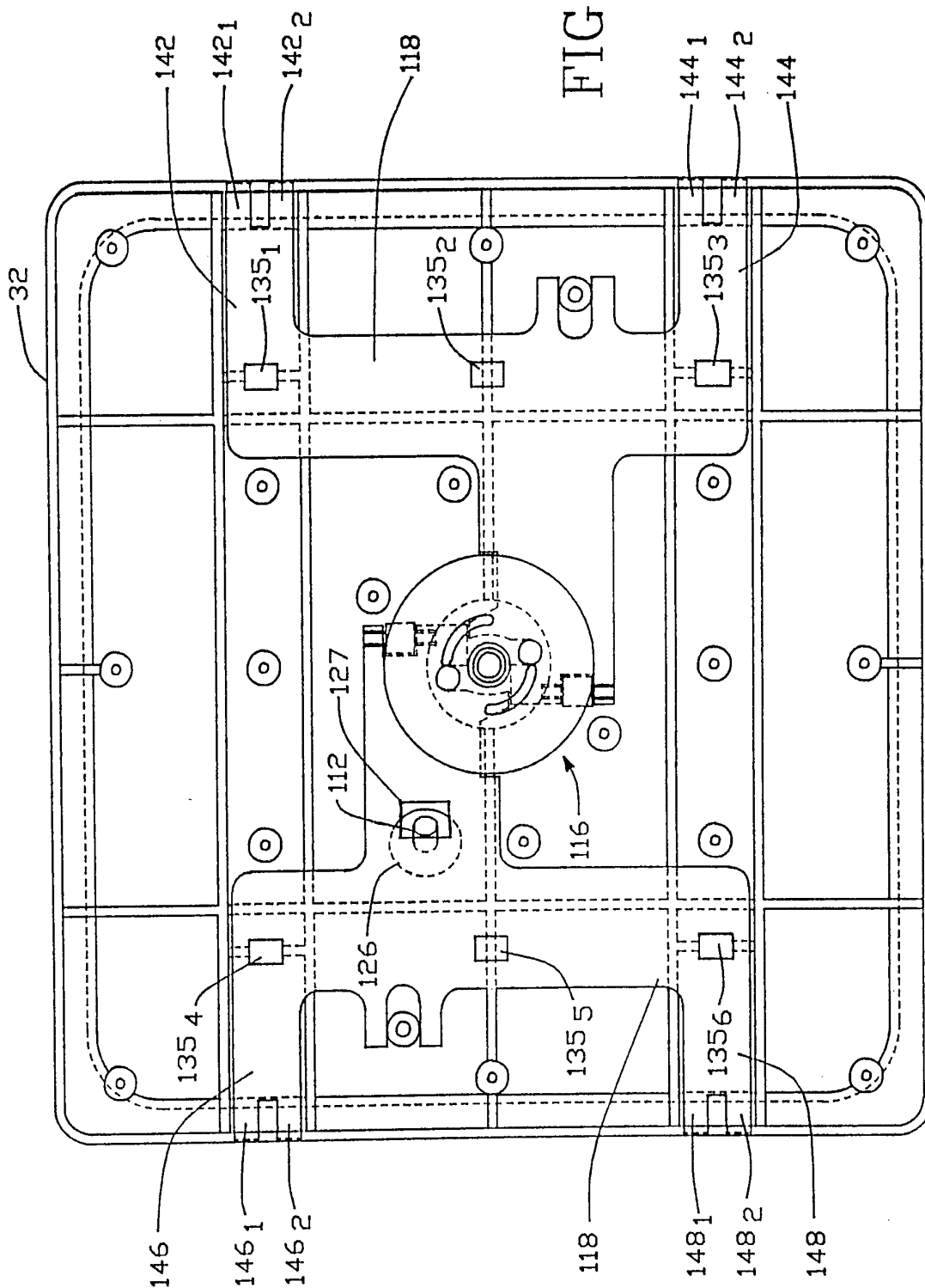

FIG. -8B

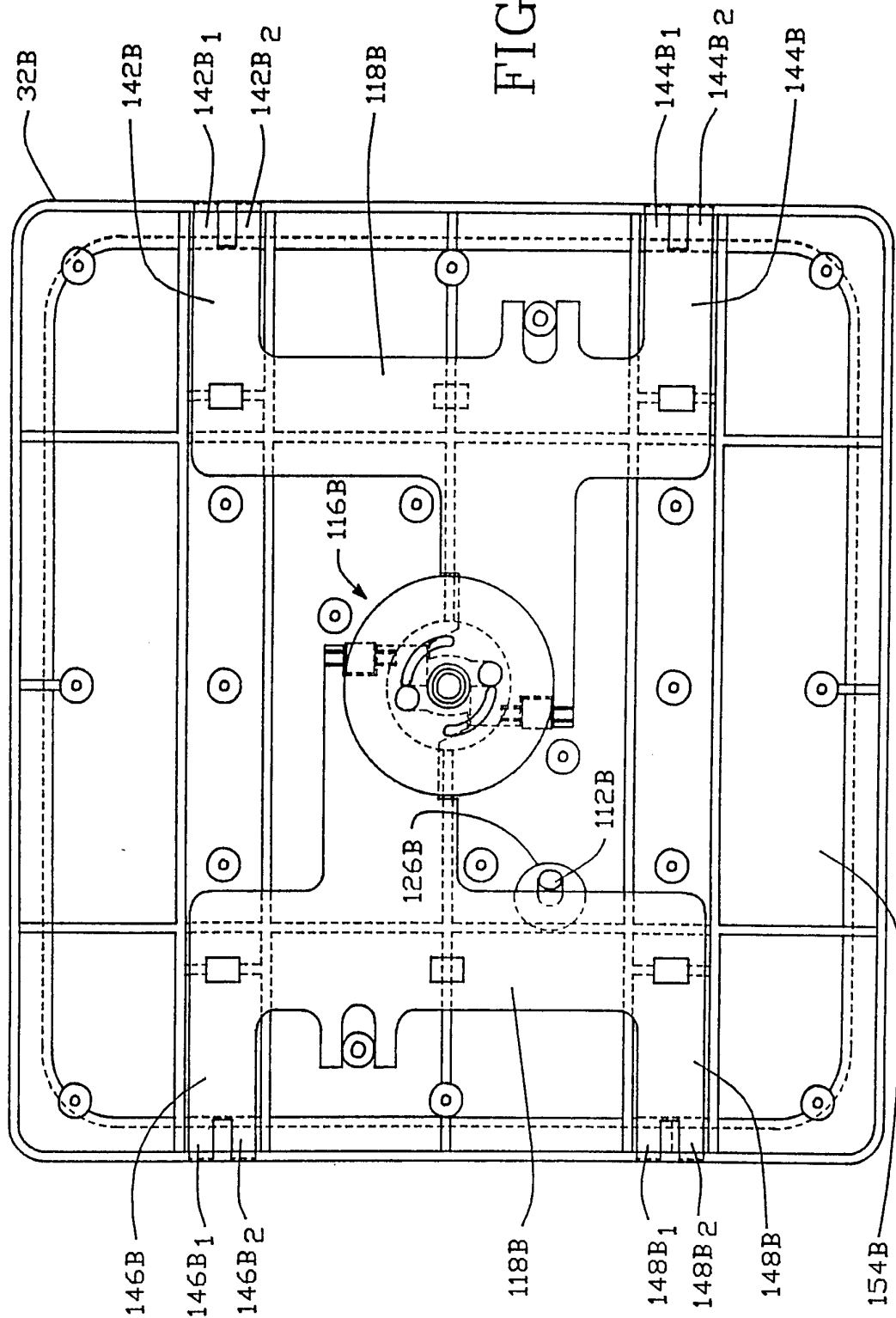

FIG. - 9A

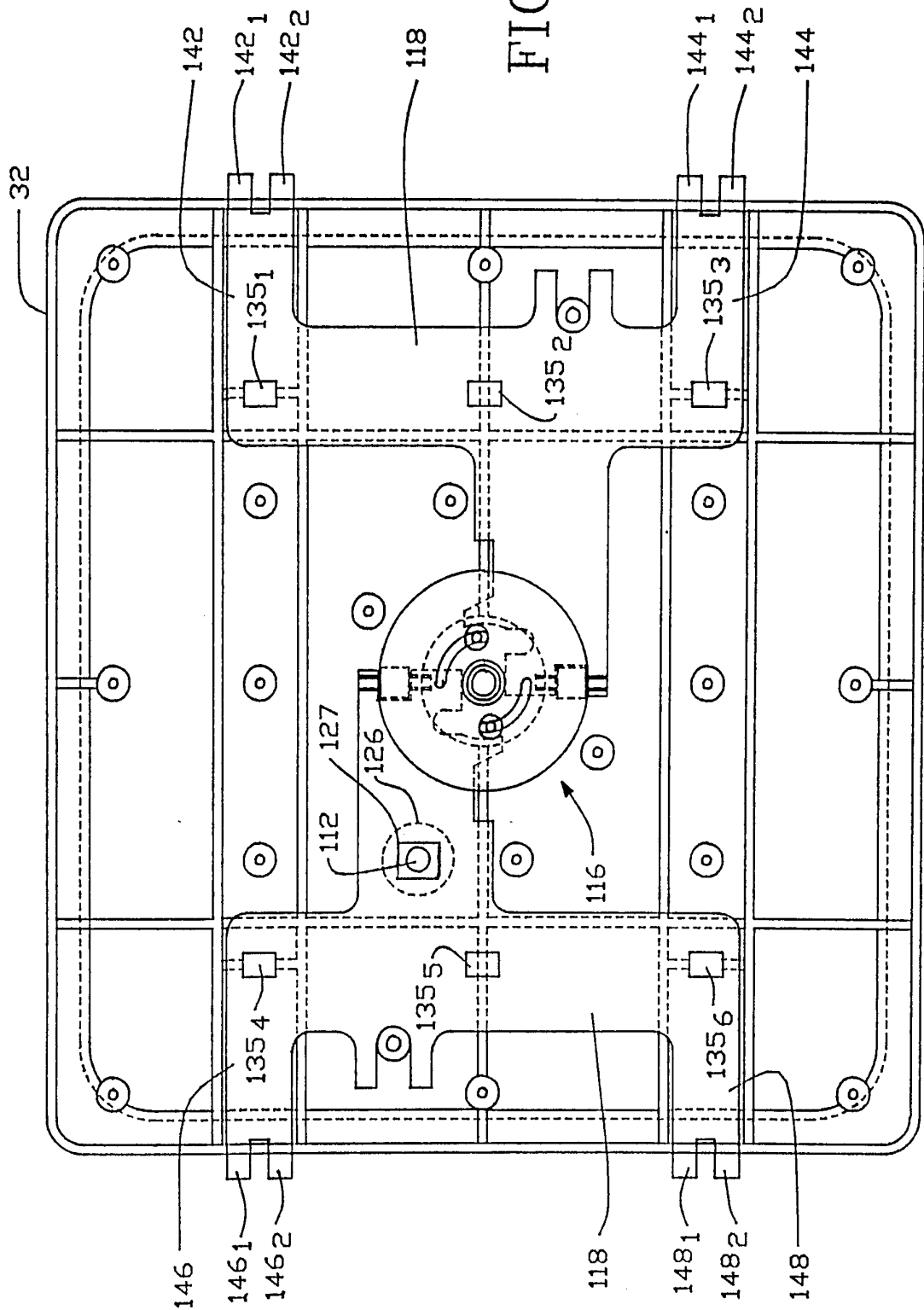
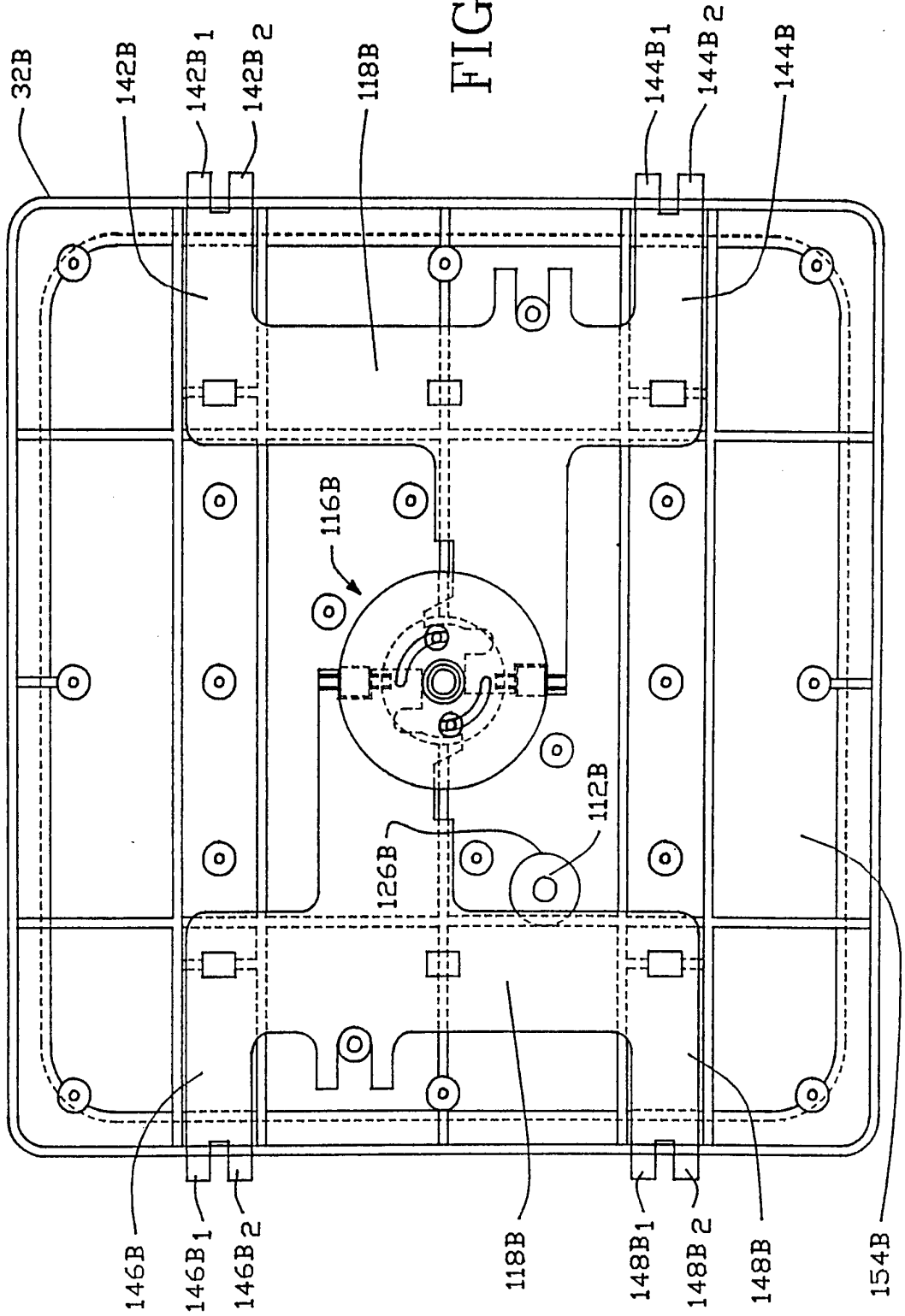

FIG. -9B



10/12

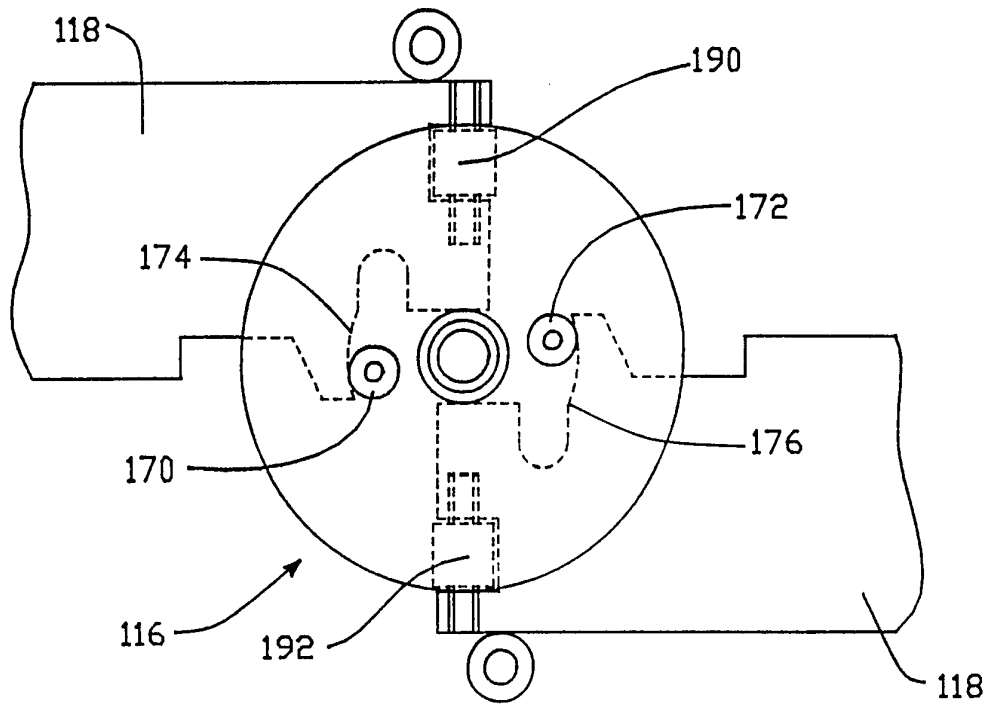

FIG. 11

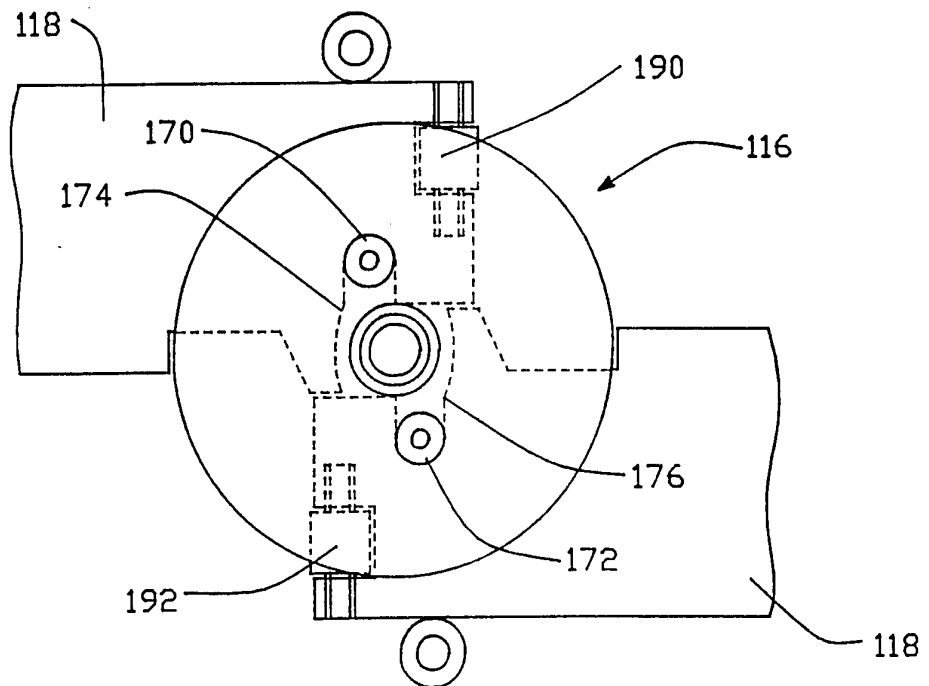

FIG. - 10

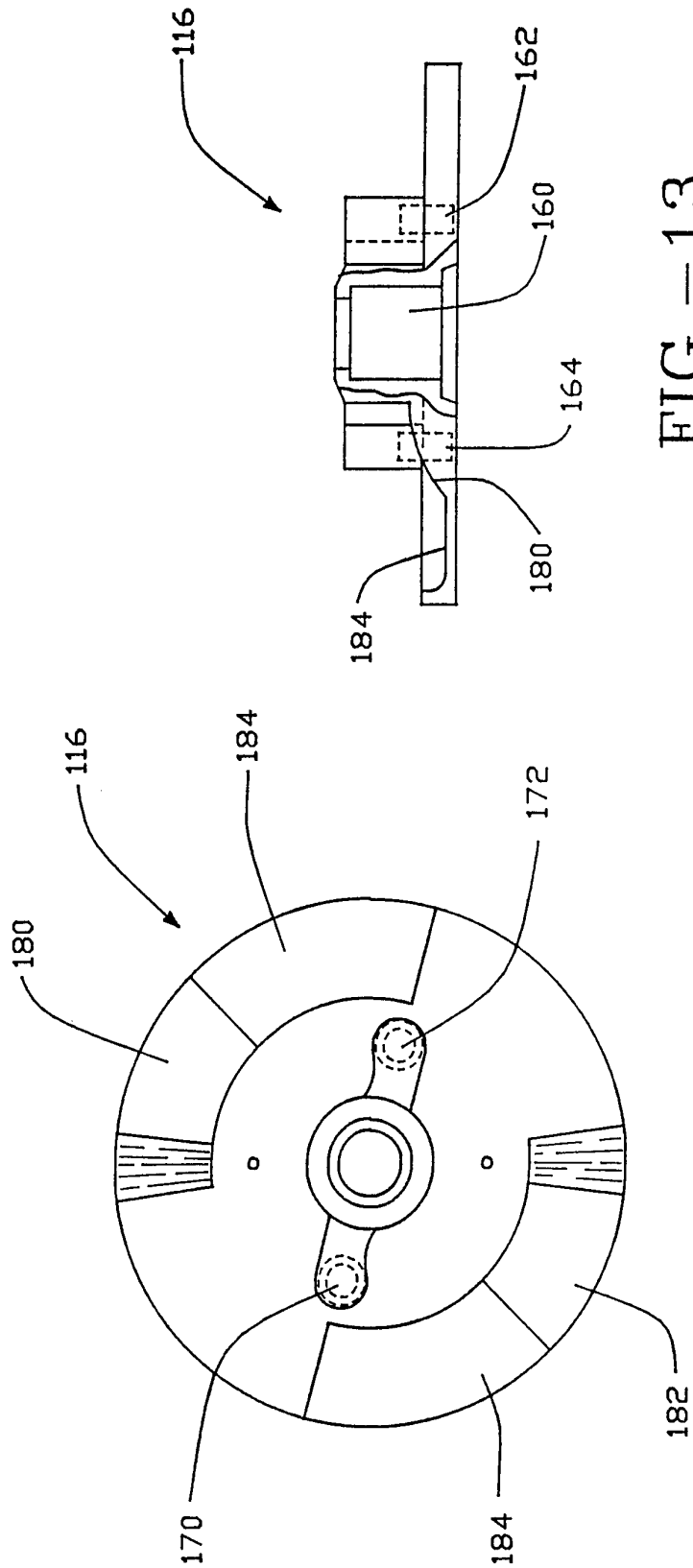

FIG.—13

FIG.—12

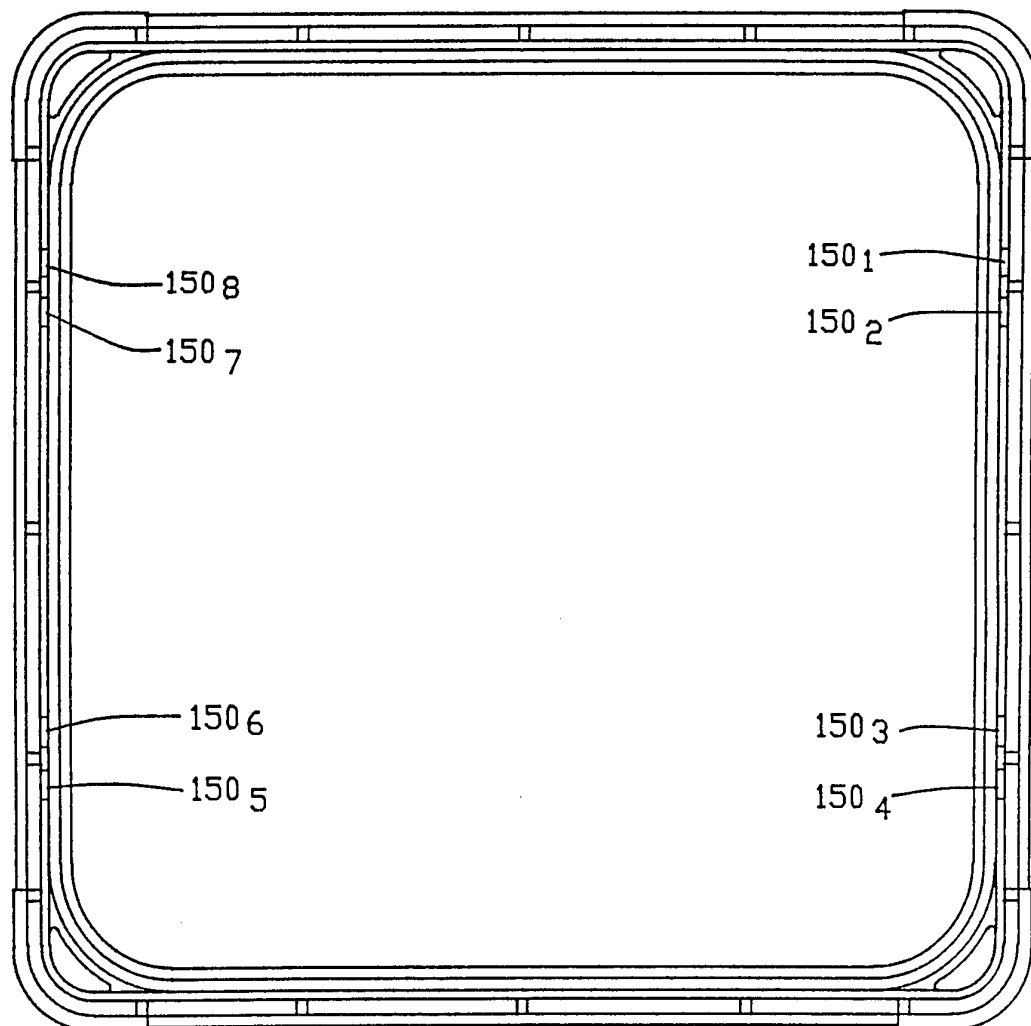

FIG. - 14

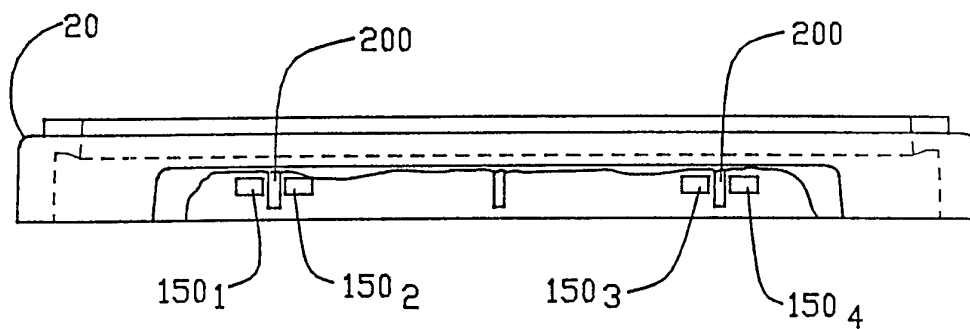

FIG. - 15

INTERNATIONAL SEARCH REPORT

International application No.
PCT/US96/11296

A. CLASSIFICATION OF SUBJECT MATTER IPC(6) :B65D 85/30 US CL :141/292 According to International Patent Classification (IPC) or to both national classification and IPC		
B. FIELDS SEARCHED Minimum documentation searched (classification system followed by classification symbols) U.S. : Please See Extra Sheet.		
Documentation searched other than minimum documentation to the extent that such documents are included in the fields searched NONE		
Electronic data base consulted during the international search (name of data base and, where practicable, search terms used) NONE		
C. DOCUMENTS CONSIDERED TO BE RELEVANT		
Category*	Citation of document, with indication, where appropriate, of the relevant passages	Relevant to claim No.
X	US, A, 2,944,699 (OETIKER) 12 JULY 1960, COL. 1, LINE 67, TO COL. 2, LINE 59.	1-3, 6-11, 13-15, 22-25
X	US, A, 4,396,130 (ROBINSON) 2 AUGUST 1983, COL. 4, LINE 51, TO COL. 5, LINE 57.	1-3, 6, 8-11, 13, 14, 22-24
X	US, A, 5,370,257 (CHAMEROY ET AL.) 6 DECEMBER 1994, COL. 3, LINE 33, TO COL. 4, LINE 43.	1-3, 6-11, 13-15, 22-25
X, P ----- Y, P	US, A, 5,482,161 (WILLIAMS ET AL.) 9 JANUARY 1996, COL. 7, LINES 34-42.	8-10 ----- 1-7, 11-15, 17-20
Y	US, A, 5,217,053 (FOSTER ET AL.) JUNE 8, 1993, COL. 3, LINE 53.	4, 5, 12
<input checked="" type="checkbox"/> Further documents are listed in the continuation of Box C. <input type="checkbox"/> See patent family annex.		
* Special categories of cited documents: *A* document defining the general state of the art which is not considered to be of particular relevance *E* earlier document published on or after the international filing date *L* document which may throw doubts on priority claim(s) or which is cited to establish the publication date of another citation or other special reason (as specified) *O* document referring to an oral disclosure, use, exhibition or other means *P* document published prior to the international filing date but later than the priority date claimed *T* later document published after the international filing date or priority date and not in conflict with the application but cited to understand the principle or theory underlying the invention *X* document of particular relevance; the claimed invention cannot be considered novel or cannot be considered to involve an inventive step when the document is taken alone *Y* document of particular relevance; the claimed invention cannot be considered to involve an inventive step when the document is combined with one or more other such documents, such combination being obvious to a person skilled in the art *&* document member of the same patent family		
Date of the actual completion of the international search 16 AUGUST 1996		Date of mailing of the international search report 05 SEP 1996
Name and mailing address of the ISA/US Commissioner of Patents and Trademarks Box PCT Washington, D.C. 20231 Facsimile No. (703) 305-3230		Authorized officer <i>H. Casimer Jacyna</i> J. CASIMER JACYNA Telephone No. (703) 308-1113

INTERNATIONAL SEARCH REPORT

International application No.
PCT/US96/11296

C (Continuation). DOCUMENTS CONSIDERED TO BE RELEVANT

Category*	Citation of document, with indication, where appropriate, of the relevant passages	Relevant to claim No.
Y	US, A, 5,169,272 (BONORA ET AL.) 8 DECEMBER 1992, COL. 6, LINES 11-44.	17-20

INTERNATIONAL SEARCH REPORT

International application No.
PCT/US96/11296

B. FIELDS SEARCHED

Minimum documentation searched
Classification System: U.S.

141/292, 291, 98; 414/217, 287, 292, 411, 422, 935, 940; 206/454, 710;
220/203.06, 203.07, 231, 316.