

April 7, 1959

H. J. DREW

2,881,003

DEVICE FOR RAISING AND LOWERING BASKETBALL BANKBOARDS

Filed Dec. 18, 1953

2 Sheets-Sheet 1

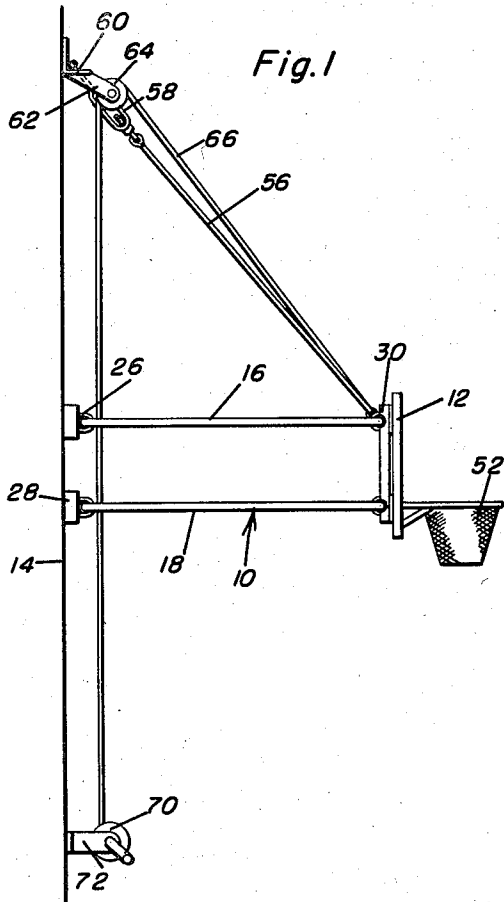

Fig. 1

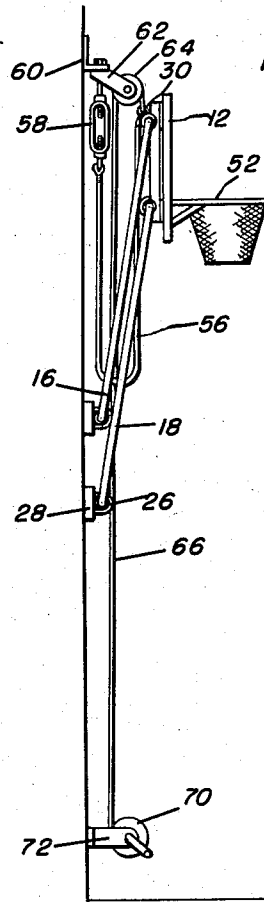

Fig. 2

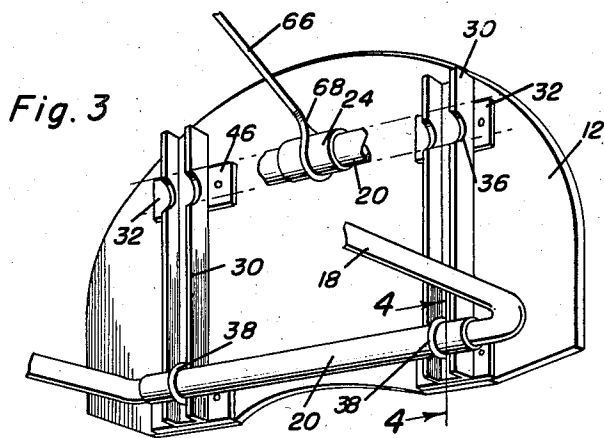

Fig. 3

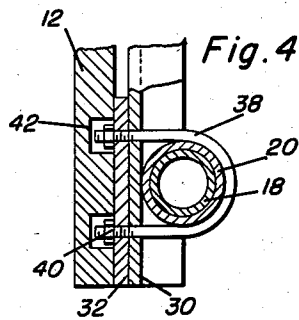

Fig. 4

Herbert J. Drew
INVENTOR.

BY *Alvanice A. O'Brien*
and *Harvey B. Jacobson*
Attorneys

April 7, 1959

H. J. DREW

2,881,003

DEVICE FOR RAISING AND LOWERING BASKETBALL BANKBOARDS

Filed Dec. 18, 1953

2 Sheets-Sheet 2

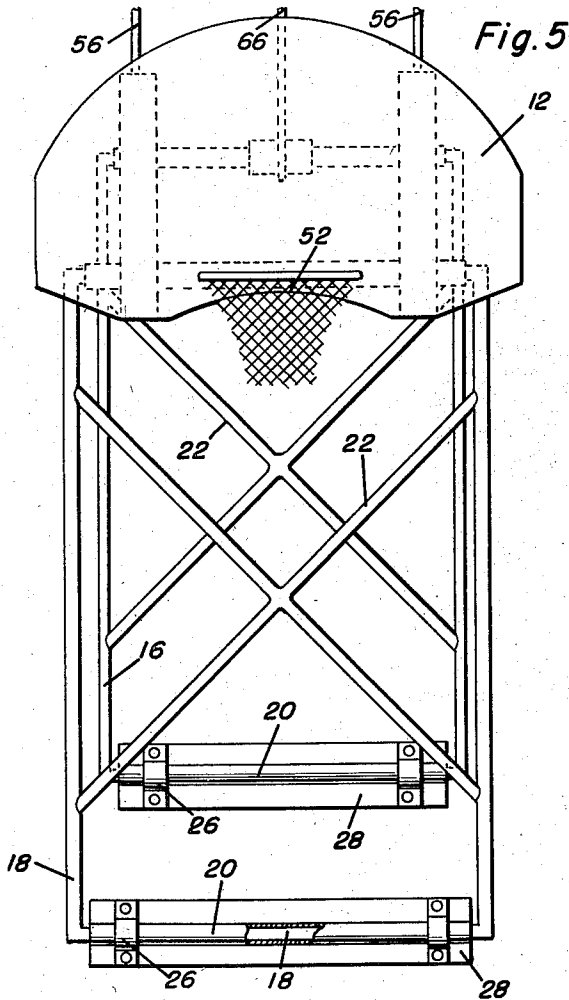

Fig. 5

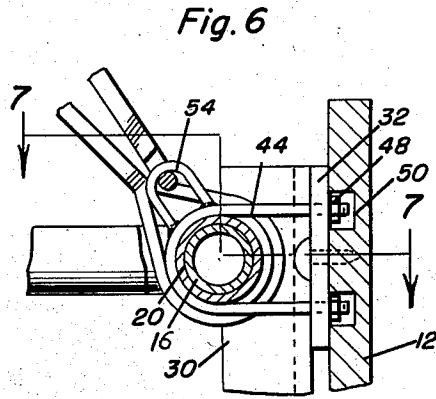

Fig. 6

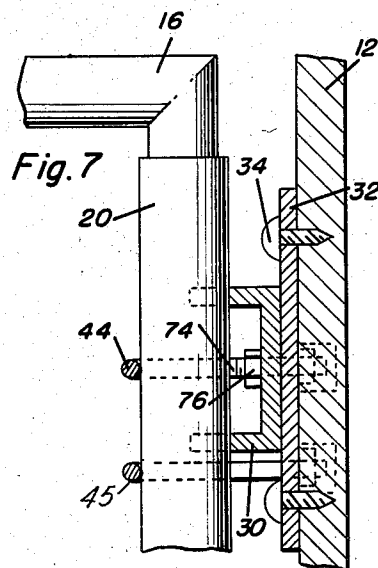

Fig. 7

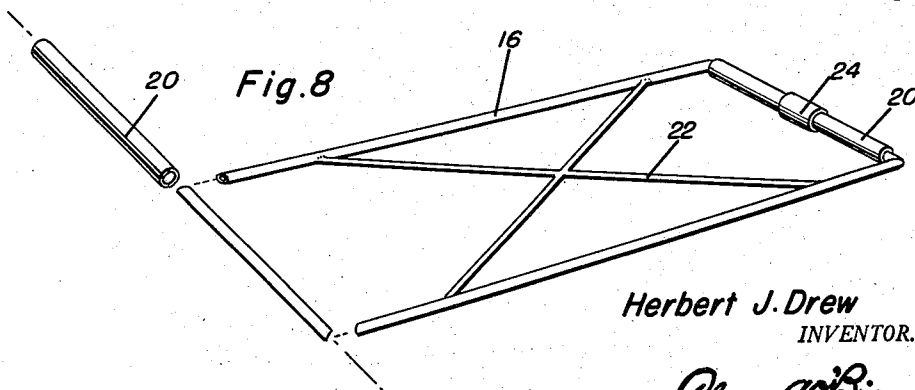

Fig. 8

Herbert J. Drew
INVENTOR.

BY *Alvanice W. Brown*
and Harvey B. Jacobson
Attorneys

1

2,881,003

DEVICE FOR RAISING AND LOWERING BASKETBALL BANKBOARDS

Herbert J. Drew, Cloquet, Minn.

Application December 18, 1953, Serial No. 398,995

2 Claims. (Cl. 273—1.5)

This invention relates to a device for raising and lowering basketball bankboards and more specifically provides an improved structure for lowering basketball bankboards to a position for playing or raising the bankboard to a retracted position adjacent a supporting surface.

An object of this invention is to provide novel structural improvements in devices for raising and lowering basketball bankboards which rigidly supports the bankboards in playing position, is economically constructed from readily available materials, simple in construction, easy in assembly and relatively easy to operate.

A further object of this invention is to provide a device for raising and lowering basketball bankboards including means for adjusting the normal playing position of the bankboard and a winch for easy manipulation of the bankboard.

These together with other objects and advantages which will become subsequently apparent reside in the details of construction and operation as more fully hereinafter described and claimed, reference being had to the accompanying drawings forming a part hereof, wherein like numerals refer to like parts throughout, and in which:

Figure 1 is a side elevational view showing the present invention with the basketball bankboard in its lowered or playing position;

Figure 2 is a view similar to Figure 1 showing the basketball bankboard raised to an inoperative position adjacent the vertical supporting surface;

Figure 3 is a detail perspective of the rear of the bankboard with portions thereof broken away showing the details of attachment of the bankboard to the supporting member;

Figure 4 is a detail section taken substantially along section line 4—4 of Figure 3 showing the attachment of the supporting member to the basketball bankboard;

Figure 5 is a front view of the construction of Figure 2 showing the bankboard in raised position;

Figure 6 is a detail section showing the upper supporting member attached to the basketball bankboard;

Figure 7 is a top plan detailed section taken substantially along section line 7—7 of Figure 6 showing the relationship between the basketball bankboard and the supporting member; and

Figure 8 is a group perspective showing the upper supporting member.

Referring now specifically to the drawings, it will be seen that the numeral 10 generally designates the raising and lowering device for a basketball bankboard 12 of the present invention. The device 10 for raising and lowering the bankboard 12 is secured to a vertical supporting surface 14 such as the side or end wall of a gymnasium or the like.

The device 10 includes an upper frame member 16 and a lower frame member 18 which act as supporting members and are in substantially horizontal parallel relation when in the lowered position as shown in Figure 1. As shown in Figure 8, the upper frame 16 includes side pieces and end pieces, with the end pieces surrounded by a

2

tubular pipe member 20 and the side pieces are rigidly braced by diagonal brace members 22. The outer end of the frame member 16 is provided with a short tubular member 24 which surrounds the tubular pipe 20. It will be understood that the frame 16 is made of tubular pipe and the surrounding tubular pipes 20 on the end pieces of the frame 16 are pivoted thereto, and suitable lubrication, such as graphite, may be employed between the tubular pipe 20 and the end pieces of the frame member 16.

The lower frame 18 is identical with the upper frame 16 with the exception of the sleeve 24, and as shown in Figure 5, the lower frame 18 is slightly wider than the upper frame 16. The frames 16 and 18 are identical in length and the inner end of the frames 16 and 18 are secured to the vertical supporting surface by the use of a pair of U-shaped straps 26 which are positioned over the tubular pipes 20 and secured to the elongated supporting blocks 28 which are secured to the vertical surface 14 in any suitable manner.

As shown in Figure 3, the bankboard 12 is provided with a pair of laterally spaced and vertically disposed channel members 30 which have brackets 32 on the web thereof and the flanges of the channel members 30 extend rearwardly towards the vertical supporting surface 14. The brackets 32 are secured to the bankboard 12 by suitable fastening means 34, as illustrated in Figure 7. The flanges of the channel-shaped member 30 are provided with vertically spaced semi-circular notches 36 for receiving the outer circumference of the tubular pipe 20 and the tubular pipe 20 on the lower frame 18 is secured to the channel member 30 by a U-shaped bolt 38 surrounding the pipe 20 and passing through apertures in the web of the channel-shaped member 30 and including nuts 40 which are secured to the threaded end portions of the U-shaped bolt 38 which projects through the bracket 32 and is received in a suitable recess 42 in the rear surface of the bankboard 12. The upper tubular member 20 on the upper frame 16 is secured to the channel member 30 by a U-shaped bolt 44 which surrounds the outer periphery of the tubular pipe 20 and is received in apertures 46 in the bracket 32 adjacent the inner flange of the channel-shaped member 30. Fastening nuts 48 are secured to the U-shaped bolt 44 and are received in sockets 50 substantially in the same manner as the U-shaped bolt 38 for retaining the lower frame 18 to the bankboard 12. The forward end of the bankboard 12 is provided with the conventional basket 52 employed in regulation basketball games, and the bankboard 12 is of a conventional shape, as set forth by basketball rules.

Each of the U-shaped bolts 44 is provided with a U-shaped extension 54 on the upper and inner end thereof for attaching a flexible cable 56 thereto. The other end of the flexible cable 56 is attached to a turnbuckle 58 which is secured to a suitable right angled bracket 60 which is vertically spaced above the supporting blocks 28. A bracket 62 is provided for supporting a pulley 64 substantially midway between the right angular bracket 60 and a flexible cable 66 is positioned thereover and terminates in a loop 68 for engaging the periphery of the tubular sleeve 24 on the tubular pipe 20 at the outer end of the upper frame 16. The other end of the flexible cable 66 is secured to a winch 70 which is positioned below the supporting blocks 28 and secured to the supporting surface 14 by a suitable bracket 72. As shown in Figure 7, U-shaped bolt means 45 similar to the bolt 44 is provided with an elongated threaded portion 74 and a suitable nut 76 for adjusting the relationship between the tubular member 20 and the channel member 30.

The operation of the device will be readily understood. By manipulating the winch 70, the bankboard 12 may be raised to the position shown in Figure 2 or lowered to a

3

position shown in Figure 1. The upper frame and the lower frame are pivotally attached to the vertical supporting surface 14, and the rear of the bankboard 12 and the frame members 16 and 18 act as portions of a pivotal parallelogram, and it will be understood that this device accurately and rigidly supports the bankboard 12 in correct playing position. The exact position may be determined by manipulation of the turnbuckle 58 and by suitable manipulation of the adjusting means 76 on the U-shaped bolt 44. Obviously, the device of this invention is constructed of readily obtainable materials and is extremely simple in construction and operation, thereby enhancing the economical feasibility and the operational feasibility of the device.

From the foregoing, the construction and operation of the device will be readily understood and further explanation is believed to be unnecessary. However, since numerous modifications and changes will readily occur to those skilled in the art, it is not desired to limit the invention to the exact construction shown and described, and accordingly, all suitable modifications and equivalents may be resorted to, falling within the scope of the appended claims.

What is claimed as new is as follows:

1. A device for raising and lowering basketball bankboards comprising a pair of rigid rectangular skeleton frame support members, elongated bearing sleeves on each end of each support member for journalling the same, means rigidly attaching the bearing sleeves at one end of the support members to a supporting surface at spaced points along the length thereof, a bankboard rigidly interconnecting the bearing sleeves at the other end of the support members and being secured thereto at spaced points along the length of the sleeves thereby providing lateral stability to the pivotal parallelogram formed by

4

the support members, supporting surface and bankboard, means for supporting said support members in generally horizontal position and the bankboard in substantially vertical position, and means for raising and lowering the support members and bankboard from a position below the support members, said bankboard including vertical channel-shaped members rigidly secured to the rear surface thereof, the legs of said channel-shaped members extending outwardly of the rear surface of the bankboard, each pair of legs having vertically spaced notches receiving the bearing sleeves, and bolt means rigidly securing the sleeves in the notches, said means attaching the bearing sleeves to a supporting surface including a pair of laterally spaced U-shaped straps.

2. The structure as defined in claim 1 wherein said supporting means includes a pair of adjustable length cables for limiting the downward movement of the bankboard, said cables being parallel and connected to the outer end of the upper bearing sleeve at points adjacent the points of attachment between the bankboard and upper bearing sleeve, said raising and lowering means including a cable connected to the center of the upper and outer bearing sleeve, a pulley on the supporting surface above the upper support member, said cable entrained over the pulley and downwardly.

References Cited in the file of this patent

UNITED STATES PATENTS

30	1,757,350	Wallace	May 6, 1930
	1,778,173	Steele	Oct. 14, 1930
	1,924,811	Schulz	Aug. 29, 1933
	2,313,188	Woodburn	Mar. 9, 1943
	2,712,445	Barclay et al.	July 5, 1955
35	2,786,678	Fink	Mar. 26, 1957