

(19) World Intellectual Property Organization
International Bureau



(43) International Publication Date
31 October 2002 (31.10.2002)

PCT

(10) International Publication Number
WO 02/087179 A2

- (51) International Patent Classification⁷: **H04L 25/00**
- (21) International Application Number: PCT/US01/23217
- (22) International Filing Date: 24 July 2001 (24.07.2001)
- (25) Filing Language: English
- (26) Publication Language: English
- (30) Priority Data:
09/836,281 18 April 2001 (18.04.2001) US
09/899,852 9 July 2001 (09.07.2001) US
- (71) Applicant (for all designated States except US): **VERTICALBAND LIMITED** [GB/GB]; Mimet House, 5a Praed Street, London W2 1NJ (GB).
- (72) Inventors; and
- (75) Inventors/Applicants (for US only): **RIESS, Eilon** [IL/GB]; 45a Froggnal, London NW3 6YA (GB). **TURNER, Lawrence** [GB/GB]; The Croft, 4 Barrells Down Road, Bishop's Stortford, Herts CM23 2SU (GB). **SABEL, Les** [AU/GB]; 21 Alvescot Road, Old Walcot, Swindon, Wiltshire SN3 1B1 (GB). **SCHWARTZ, Stuart** [US/US]; 4 Evelyn Place, Princeton, NJ 08540 (US).
- (74) Agents: **BRAINARD, Charles, R.** et al.; Kenyon & Kenyon, 1500 K Street, N.W., Suite 700, Washington, DC 20005 (US).
- (81) Designated States (national): AE, AG, AL, AM, AT, AU, AZ, BA, BB, BG, BR, BY, BZ, CA, CH, CN, CO, CR, CU, CZ, DE, DK, DM, DZ, EC, EE, ES, FI, GB, GD, GE, GH, GM, HR, HU, ID, IL, IN, IS, JP, KE, KG, KP, KR, KZ, LC, LK, LR, LS, LT, LU, LV, MA, MD, MG, MK, MN, MW, MX, MZ, NO, NZ, PL, PT, RO, RU, SD, SE, SG, SI, SK, SL, TJ, TM, TR, TT, TZ, UA, UG, US, UZ, VN, YU, ZA, ZW.
- (84) Designated States (regional): ARIPO patent (GH, GM, KE, LS, MW, MZ, SD, SL, SZ, TZ, UG, ZW), Eurasian patent (AM, AZ, BY, KG, KZ, MD, RU, TJ, TM), European patent (AT, BE, CH, CY, DE, DK, ES, FI, FR, GB, GR, IE, IT, LU, MC, NL, PT, SE, TR), OAPI patent (BF, BJ, CF, CG, CI, CM, GA, GN, GQ, GW, ML, MR, NE, SN, TD, TG).
- Published:**
— without international search report and to be republished upon receipt of that report
- For two-letter codes and other abbreviations, refer to the "Guidance Notes on Codes and Abbreviations" appearing at the beginning of each regular issue of the PCT Gazette.*



WO 02/087179 A2

(54) Title: RELIABLE SYMBOLS AS A MEANS OF IMPROVING THE PERFORMANCE OF INFORMATION TRANSMISSION SYSTEMS

(57) Abstract: All practical communication channels impose some type of corruption on received data through inter-symbol interference (ISI). ISI corruption is particularly acute in high-order constellation transmission. Although ISI effects of high-order constellation transmission are very large on average, some symbols may be received that suffer relatively low levels of ISI. These symbols are "reliable symbols" and can be used to provide blind estimation of the ISI coefficients. Once the ISI effects of a channel are known, all captured signals may be corrected.

**RELIABLE SYMBOLS AS A MEANS OF IMPROVING THE PERFORMANCE OF
INFORMATION TRANSMISSION SYSTEMS**

5 **CROSS-REFERENCE TO RELATED APPLICATIONS**

This application is a continuation-in-part of the following applications: U.S. Patent Application No. 09/836,281, filed April 18, 2001, WIPO 0/02634, filed July 10, 2000 (which benefits from the priority of UK application 16938.3, also filed July 10, 2000), and WIPO 00/02648, filed July 10, 2000 (which benefits from the priority
10 of UK application 9926167.4, filed November 4, 1999), the disclosures of which is incorporated herein by reference. Certain claims may benefit from the priority of these applications.

BACKGROUND

The present invention relates to a data processing technique that permits
15 identification of reliable symbols in the presence of Inter-Symbol Interference (“ISI”) and other data correlated noise (collectively, “ISI”). Data correlated noise refers to a variety of phenomena in data processing systems in which a data signal interferes with itself at a destination. The present invention also relates to the use of reliable symbols to determine values of source symbols that are corrupted by ISI. The
20 present invention finds application in systems where source symbols are members of high-order constellations. Previously, such systems have required the use of training symbols for operation in the presence of real-world ISI phenomenon.

FIG. 1 illustrates an exemplary data processing system 100 in which ISI may occur. A source 110 may generate a data signal **X** (herein, a “source data signal”).
25 When delivered to a destination 120 as a received signal **Y**, the source data signal **X** may be corrupted by ISI sources 130. For example, multiple copies of a single data signal **X** may be captured at the destination 120, each copy being received with an unknown time shift and gain with respect to the other copies. Further, the time shifts and gains may vary over time.

ISI phenomena may be modeled mathematically. In the case where the data signal \mathbf{X} is populated by a number of data symbols x_n , captured signals y_n at the destination 120 may be represented as:

$$y_n = a_0 \cdot x_n + f(x_{n-K_1}, \dots, x_{n-1}, x_{n+1}, \dots, x_{n+K_2}) + \omega_n \quad (1)$$

5 where a_0 represents a gain factor associated with the channel 130, $f(x_{n-K_1}, \dots, x_{n+K_2})$ is a functional representation that relates the ISI to the symbols, $x_{n-K_1}, \dots, x_{n+K_2}$, causing ISI corruption and ω_n represents corruption from other sources. In linear systems, equation 2 may reduce to:

$$y_n = x_n + \sum_{\substack{i=-K_1 \\ i \neq 0}}^{K_2} a_i \cdot x_{n-i} + \omega_n \quad (2)$$

10 where a_{-K_1}, \dots, a_{K_2} represent the sampled values of the impulse response of the channel. In accordance to common practice, the values a_i have been normalized by the value of a_0 in equation 2.

ISI may arise from a variety of real-world phenomena. Multipath is an example of ISI that occurs in wireless and other communication systems. In a wireless system 15 200, shown in FIG. 2, a base station 210 may transmit data addressed to a mobile station 220 over a region of space, typically a cell or a cell sector. The mobile station 220 may receive the signal via a direct line-of-sight path and also may receive copies of the data signal via other indirect paths. The indirect paths may be caused by reflections of the transmitted signal from structures in the transmission environment 20 such as buildings, trucks, mountains and the like. At the mobile station 200, the directly received and indirectly received signals interfere with each other. The indirect transmissions, however, because they travel a longer propagation path before they reach the mobile station, are delayed with respect to the direct path signal.

ISI is seen as a serious impediment to the use of high-order constellations for 25 data processing systems. A "constellation" represents a set of unique values that may be assigned to data symbols. Several examples are shown in FIG. 3. FIGS. 3 (a)-(c) illustrate constellations for amplitude shift keying ("ASK") applications where symbols can take one of four, eight or sixteen unique values. When compared to a binary symbol constellation, use of these constellations yields data throughput increases by 30 factors of 2 (four levels), 3 (eight levels) or 4 (sixteen levels). FIGS. 3 (d)-(f) illustrate

constellations for quadrature amplitude modulation ("QAM") applications where symbols can take one of four, sixteen or sixty-four unique values. When compared to a binary symbol constellation, use of these constellations yield data throughput increases of 2 (four levels), 4 (sixteen levels) and 6 (sixty-four levels). Thus, use of
5 high-order constellations in data processing systems can yield increased throughput over binary systems within the same bandwidth.

The problem is that, when using high-order constellations, blind equalization (equalization without either an initial training sequence, or 'refresher' training sequences) is very hard to achieve because the detrimental effects of ISI increase with
10 increasing constellation order.

There is a need in the art for a data transmission system that, in the presence of realistic levels of ISI, uses blind techniques to decode symbols from a high-order constellation.

BRIEF DESCRIPTION OF THE DRAWINGS

15 FIG. 1 illustrates an exemplary data processing system in which ISI may occur.

FIG. 2 illustrates an exemplary communication system in which ISI may occur due to multipath.

FIG. 3 illustrates various symbol constellations.

20 FIG. 4 illustrates a method of operation for detecting reliable symbols according to an embodiment of the present invention.

FIG. 5 illustrates a method of operation for detecting reliable symbols according to an embodiment of the present invention.

FIG. 6 illustrates another method of operation 3000 for detecting reliable symbols

25 FIG. 7 is a block diagram of a data decoder according to an embodiment of the present invention.

FIG. 8 illustrates a data decoding method of operation according to an embodiment of the present invention.

FIG. 9 is a block diagram of a data decoder according to another embodiment of the present invention.

FIG. 10 is a block diagram of a receiver structure according to an embodiment of the present invention.

5 **DETAILED DESCRIPTION**

Embodiments of the present invention identify reliable symbols from a sequence of captured signal samples at a destination. Although the ISI effects associated with high-order symbol constellation transmissions impose large signal corruption on average, some samples suffer relatively low levels of ISI. These samples are the reliable symbols. Having identified reliable symbols from a sequence of captured signal samples, it is possible to reliably estimate the actual source symbols for all captured signal samples.

Identification Of Reliable Symbols

A “reliable symbol” is a captured sample y_n that is very likely to be located within a decision region of a corresponding source symbol x_n transmitted from the source 110 at time n . At a destination 120, each constellation symbol is associated with a decision region that represents a set of all points that are closer to the respective symbol than to any other symbol in the constellation. FIG. 3(e) shows exemplary decision regions 140, 150 for symbols $-1,-1$ and $1,3$ in the 16-level QAM constellation. For a reliable symbol, the combined ISI and additive noise effects and other channel and system impairments are unlikely to have pushed the captured sample y_n from a decision region of the symbol x_n from which it originated.

According to an embodiment of the present invention, identification of a signal y_n as “reliable” may be carried out using a reliability factor R_n given by:

$$25 \quad R_n = \sum_{\substack{i=-K_1 \\ i \neq 0}}^{K_2} |y_{n-i}| \cdot c_i \quad (3)$$

where the c_i are constants representing any priori knowledge of the ISI effect that may be available. Generally, if nothing is known about the ISI, then the c_i 's may all be set equal to 1. In other situations, additional information as to the nature of the channel 130 may be known and the c_i 's may be given values reflecting this information. If the

reliability factor of a sample y_n is less than a predetermined limit value, designated “ d_{lim} ” herein, the sample may be designated as a “reliable symbol.”

Where samples on only one side of a candidate sample y_n contribute to the ISI, the reliability factor of the sample y_n may be determined using:

$$5 \quad R_n = \sum_{i=1}^K |y_{n-i}| \cdot c_i \quad (4)$$

where $K=K_2$ in equation 3. In respect to the forgoing reliability factors (equations (3) and (4)) the y_n 's may be real for one-dimensional signal structures or complex for two-dimensional signal structures.

10 For systems using two-dimensional constellations, such as the QAM constellations shown in FIG. 3(d)-(f), the reliability factor may be determined using:

$$R_n = \sum_{\substack{i=-K_1 \\ i \neq 0}}^{K_2} \sqrt{y_{1-n-i}^2 + y_{2-n-i}^2} \cdot c_i \quad (5)$$

where y_{1-n-i}^2 and y_{2-n-i}^2 respectively represent values of y_{n-i} in the first and second dimensions.

15 In another embodiment, the reliability factor R_n may be calculated based on the constellation symbols that are closest to the captured samples. Each captured sample y_n will be closest to one constellation point p_n from the constellation

$$p_n = \{CP_p : \min(CP - y_n)\} \quad (6)$$

where CP is the set of all possible received constellation points.

20 In this embodiment, reliability factors may be determined from the constellation points p_n according to one of:

$$R_n = \sum_{\substack{i=-K_1 \\ i \neq 0}}^{K_2} |p_{n-i}| \cdot c_i, \quad R_n = \sum_{i=1}^K |p_{n-i}| \cdot c_i \quad \text{or} \quad R_n = \sum_{\substack{i=-K_1 \\ i \neq 0}}^{K_2} \sqrt{p_{1-n-i}^2 + p_{2-n-i}^2} \cdot c_i \quad (7)$$

These formulae simply are an extension of equations 3-5 substituting p_{n-i} for y_{n-i} .

25 FIG. 4 is a flow diagram of a reliable symbol detection method 1000 according to an embodiment of the present invention. According to the method, reliable symbol detection may begin by calculating a reliability factor of a sample y_n based on values

of neighboring samples (box 1010). Thereafter, the method may determine whether the reliability factor is less than or equal to a predetermined threshold (box 1020). If so, the sample y_n may be designated as a reliable symbol (box 1030). Otherwise, the sample y_n is not reliable.

5 The predetermined threshold d_{lim} may be determined based on the applications for which the identification method is to be used. In one embodiment, the threshold may be set to the value $d_{lim} = (K_1 + K_2) \cdot d_{min}$ where d_{min} is half the distance between two constellation points that are closest together. This threshold is appropriate for the case where $\frac{1}{|a_0|} \sum_{i=0}^{K_2} |a_i| \leq 1$. Experiments have shown, however, that

10 operation can be maintained using the same threshold when $\frac{1}{|a_0|} \sum_{i=0}^{K_2} |a_i| \leq 1.4$.

The threshold d_{lim} also may vary over time. If the predetermined threshold is increased, then an increased number of samples will be accepted as reliable symbols though, of course, all of these symbols will not be of the same reliability. Similarly, by decreasing the threshold d_{lim} , the number of samples that are designated as reliable symbols will decrease. These symbols will be those symbols with lower reliability factors. During operations of a reliable symbol detection method, the threshold d_{lim} may be varied to maintain a rate of detected reliable symbols at a desired value. For example, if a rate of detected symbols falls below a first rate threshold, the d_{lim} value may be increased. Or, if the rate of detected symbols exceeds a second rate threshold, the d_{lim} value may be decreased.

In other embodiments, samples may be identified as reliable symbols based not only on reliability factors of the samples R_n but also may be based on the values of the sample itself (y_n, p_n). In a given application, reliability factors of a plurality of candidate samples (say, y_1, y_2, y_3) each may be at or near the threshold ($R_n(y_n) \approx d_{lim}, \forall n=1,2,3$). In this case, the candidate samples may be prioritized according to the magnitude of the samples themselves, sorting either in ascending order of sample value or descending value of sample value as may be appropriate in a given application. Similarly, after equalization has begun and estimated source symbols \hat{x}_n become available, prioritization among candidate samples may be made according to the magnitude of the estimated symbols. Additionally, identification of

reliable symbols may be based not only upon reliability factors R_n but also on the sample values y_n or estimated symbol values \hat{x}_n themselves. In this embodiment, a sample may be designated as a reliable symbol if the reliability factor is less than a first threshold d_{lim} and if the sample value y_n (or symbol value \hat{x}_n) is less than a second threshold value. In this embodiment, these two conditions are required to be met before a sample is designated as a reliable symbol.

FIG. 5 is a flow diagram of a method of operation 2000 to determine whether a candidate sample y_n is a reliable symbol. For operation of the method, an index variable i may be set to $-K_1$ and a reliability counter R_n may be set to zero ($R_n=0$) (box 2010). The method may begin by adding to reliability counter R_n the value of a sample y_{n-i} ($R_n=R_n+|y_{n-i}|$) (box 2020). Thereafter, if the reliability counter R_n exceeds a predetermined limit (box 2030), the candidate symbol may be disqualified as a reliable symbol (box 2040). In this case, operation of the method 2000 may cease for the candidate sample y_n .

If at box 2030 the reliability counter R_n does not exceed the predetermined limit, the method may continue. The index value i may be incremented (box 2050). If $i=0$, if $n-i$ points to the candidate symbol y_n itself (box 2060), the index value may be incremented again. Otherwise, the method 2000 may determine whether i is greater than K_2 (box 2070). If so, then the candidate sample y_n is a reliable symbol (box 2080). Otherwise, the method may return to the operation at box 2020 and add to the reliability counter based on the value of the next sample y_{n-i} .

The foregoing description of the method 2000 has presented operation when no a priori knowledge of the channel is available at the destination 120 (e.g., $c_i=1$ for all i). When knowledge of the channel is available and c_i values may be determined for one or more i , then at box 2020 the reliability counter R_n may increment according to $R_n=R_n+c_i \cdot |y_{n-i}|$ (shown as bracketed text in box 2020).

In this way, the method of operation 2000 examines the neighboring samples of y_n (K_1 postcursors and K_2 precursors) to see if y_n meets the criterion for being a reliable symbol.

When a destination captures a plurality of samples y_n , each sample may be considered according to the method of FIG. 5 to determine whether the sample is a reliable symbol. Operation of the method 2000 can be accelerated in certain

embodiments. If, for example, a sample, say y_j , by itself exceeds the reliability threshold then none of the neighboring symbols y_i , $i=j-K_1$ to $j+K_2$, can be reliable symbols. In this case, the method 2000 need not be operated upon these neighboring symbols. The procedure can advance by skipping ahead to examine the first sample y_n that does not include y_j in its group of surrounding samples. In this embodiment, although the value of y_j may disqualify neighboring samples from being reliable symbols, y_j itself may be a reliable symbol. The method 2000 may operate on y_j to determine whether it is a reliable symbol.

Additionally, the surrounding samples may be selected, as a sub-set of the full range $i = -K_1$ to K_2 and the associated surrounding samples be examined. If a sequence of, say, three samples y_j to y_{j+2} have values that would cause the reliability limit d_{lim} to be exceeded, then any sample y_i having the sequence of samples within the $-K_1$ to K_2 window need not be considered under the method 2000 of FIG. 5.

An alternate embodiment finds application where ISI corruption is expected to be linear and caused by symbols from only one side of a candidate symbol, according to:

$$y_n = x_n + \sum_{i=1}^{K_2} a_i \cdot x_{n-i} + \omega_n \quad (8)$$

In such an embodiment, the iterative scan illustrated in FIG. 5 may simplify since K_1 is equal to zero.

FIG. 6 illustrates another method of operation 3000 for detecting reliable symbols when ISI effects are expected to be linear and no knowledge of the coefficients c_i is available. The method 3000 may initialize an index value i to $-K_1$ (box 3010). The method may determine whether the absolute value of a symbol y_{n-i} occurs within a predetermined limit (box 3020). If not, the method terminate for candidate symbol y_n ; it will not be designated as a reliable symbol (box 3030). If the value of y_{n-i} does occur within the predetermined limit, however, the method may increment i (box 3040). Thereafter, the method may determine whether $i=0$ (box 3050). If so, the method may return to box 3040 and increment i again. Thereafter, the method may determine whether $i>K_2$ (box 3060). If so, the sample y_n may be designated as a reliable symbol (box 3070). If not, the method may return to box 3020 for testing of other samples.

In QAM systems, there are several alternatives to detect reliable symbols. As shown in FIGS. 3 (d)-(f), QAM constellation points may be mapped as a two-dimensional coordinate space of in-phase data ("I") and quadrature-phase data ("Q"). In the simplest embodiment, where ISI is known to corrupt I data and Q data independently of each other, reliability factors may be established independently for I and Q data. That is, any of the methods of FIG. 6 may be performed for independently I and Q data. A sample's reliability may be calculated for the Q domain without regard for the sample's I value and also calculated for the I domain without regard for the sample's Q value. It may occur that a symbol will be considered reliable for I but not for Q or vice versa. This is appropriate since this technique is to be used in circumstances where it is known that the ISI in each domain are independent.

The method of FIG. 6 finds application in other embodiments where ISI is not known to be real. In such a case, the predetermined limit may be based on rectangular "rings" of the constellation. With reference to FIG. 3(f), for example, a first constellation ring may include the set of (I,Q) constellation points: 1,1, 1,-1, -1,-1 and -1,1 (shown as 160 in FIG 3 (f)). A second constellation ring may include the set of constellation points: 3,3, 3,1, 3,-1, 3,-3, 1,-3, -1,-3, -3,-3, -3,-1, -3,1, -3,3, -1,3 and 1,3 (shown as 170 in FIG 3 (f)). Higher order constellations may have additional rings. In this embodiment, the method determines whether values of the samples $y_{n,i}$ occur within a predetermined rectangular ring or any lower-order ring.

In an embodiment, the methods of FIGS. 5 and 6 may be used with constellation points $p_{n,i}$ substituting for the $y_{n,i}$ as discussed above.

Alternatively, reliable symbols may be identified according to one or more of the techniques described in the Applicant's co-pending PCT patent application PCT/GB00/02634, entitled "Adaptive Blind Equaliser," filed 10th July 2000, the subject matter of which is incorporated herein by reference.

The foregoing discussion has described various embodiments for identification of reliable symbols in a captured signal stream. Reliable symbols may be decoded immediately without further processing. Thus, for the set Y_{RS} of reliable symbols, $y_n \in Y_{RS}$, a data decoder in a destination 120 may generate decoded symbols \hat{x}_n to be the constellation point closest to y_n . The decoded symbol \hat{x}_n may be the destination's estimate of the source data symbol x_n .

The foregoing embodiments find application in applications in which captured samples y_n do not exhibit phase offset with respect to the source symbols x_n . Of course, in some applications, it may be expected that the captured samples y_n will exhibit a phase offset with respect to their source symbols x_n . Where captured samples y_n exhibit a phase rotation with respect to the source symbols x_n , a “reliable symbol” may be defined alternately as a sample y_n that is likely to be observed in the annular constellation ring of its source symbol x_n . Restated, ISI corruption is unlikely to push the source symbol x_n from its constellation ring when observed as the captured sample y_n at the destination 120. The reliability factor of equation 3 may be applied in this embodiment, using observed power levels of the captured samples:

$$R_n = \sum_{\substack{i=-K_1 \\ i \neq 0}}^{K_2} \sqrt{\text{Power}(y_{n-i}) \cdot c_i}, \quad (9)$$

and, equation 5 may be used.

Exemplary annular constellation rings are shown in FIG. 3(g). For any given symbol point (such as point (1,5)) there will be a plurality of symbols having the same distance from the constellation center. These symbols define a circle 180. Other constellation symbols define other circles, such as 190-1 and 190-2 in FIG. 3(g). Each circle may be associated with an annular ring (not shown) that includes all points in the constellation space that are closer to the circle than to any other circle in the constellation.

The methods of FIGS. 4 and 5 may find application when captured samples y_n exhibit phase offset with respect to their source symbols x_n . In this case, the threshold d_{lim} may be set according to half the width of the annular ring in which the captured sample y_n is observed.

In one embodiment a subset of the total range of power levels of y_n may be used.

Use Of Reliable Symbols

In further embodiments of the present invention, reliable symbols may be used as a basis for decoding transmitted symbols x_n from received non-reliable captured samples that are not reliable symbols ($y_n \notin Y_{RS}$). A description of these embodiments follows.

FIG. 7 is a block diagram of a data decoder 300 according to an embodiment of the present invention. The data decoder 300 may include a reliable symbol detector 310, an adaptation unit 320 and a symbol decoder 330. The reliable symbol detector 310 may identify a plurality of reliable symbols $y_{RS} \in Y_{RS}$ from a sequence of captured samples y_n . The reliable symbol detector 310 may output the reliable symbols y_{RS} and their surrounding samples (labeled y_i in FIG. 7) to the adaptation unit 320. Based upon y_{RS} and y_i , the adaptation unit 320 may generate ISI metrics that characterize the ISI signal corruption 130 (FIG 1). The adaptation unit 320 may output to the symbol decoder 330 data M_{ISI} representing the ISI metrics. Based upon the ISI metrics, M_{ISI} , the symbol decoder 330 may generate decoded symbols \hat{x}_n from the captured samples y_n , for all n , regardless of whether the sample y_n is a reliable symbol or not.

FIG. 8 illustrates a data decoding method 3000 according to an embodiment of the present invention. According to the method, a data decoder may identify a set of reliable symbols Y_{RS} from a sequence \mathbf{Y} of captured samples (Step 3010). Using this set of reliable symbols Y_{RS} and their neighbors, the data decoder may estimate an ISI metric (Step 3020). Thereafter, using the ISI metric, the data decoder may decode symbols \hat{x}_n from the sequence \mathbf{Y} of captured samples (Step 3030).

Adaptation and symbol correction techniques per se are known. In communication applications, such techniques often are provided within channel equalizers. A variety of channel equalization techniques are known, including both time-domain equalizers and frequency-domain equalizers. At a high level, adaptation refers to the process by which the equalizer learns of the ISI corruption effects and symbol correction refers to a process by which the equalizer reverses the ISI effects to determine from the sequence of captured samples \mathbf{Y} what the source symbol sequence \mathbf{X} is most likely. However, for these existing techniques to work, in the presence of realistic level of ISI when operating with high-order constellations, it would be necessary to use an initializing training sequence and thereafter to use training sequences that are transmitted periodically. The use of the reliable symbols method overcomes this need. Any of a variety of known equalizers may be used with the reliable symbols technique and the adaptation process -- the process by which the equalizer learns -- can be rendered blind. Having learned what the ISI effects are

based on the reliable symbols y_{RS} , the equalizer may decode symbols \hat{x}_n from all of the captured samples y_n .

Perhaps the simplest embodiment of equalizer is the subtractive equalizer. In the subtractive equalizer, the adaptation unit 320 estimates the channel ISI coefficients \hat{a}_i . Using the estimated coefficients \hat{a}_i the symbol decoder 330 may estimate source symbols, \hat{x}_n , by decoding y'_n where:

$$y'_n = y_n - \sum_{i=1}^{K_2} \hat{a}_i \cdot \hat{x}_{n-i} \quad (10)$$

in which \hat{x}_{n-i} represent prior decoded symbols. The equalizer may generate a decoded symbol \hat{x}_n as the constellation symbol that is closest to y'_n .

As noted, different types of equalizers can be used. A decision feedback equalizer (also "DFE") may be incorporated within the symbol decoder 410 of the system 400 shown in FIG. 9. Conventionally a DFE is fed with information obtained from training sequences. In an embodiment employing reliable symbols, information may be fed to the adaptation unit 420. The adaptation unit 420 may update the tap settings of the DFE.

In this embodiment shown in FIG. 9, the reliable symbol detector 430 may identify reliable symbols from the captured samples y_n . An output of the reliable symbol detector 430 may be an enabling input to the adaptation unit 420. When a reliable symbol is identified, the adaptation unit 420 may be enabled, causing it to revise its estimate of the ISI metrics M_{ISI} .

The foregoing embodiments have described use of reliable symbols to extend application of known adaptation processes to ISI estimation for high-order constellations in the presence of realistic levels of ISI without the use of training sequences. By extension, this use of reliable symbols permits data decoders to estimate high-constellation source symbols \mathbf{X} from a sequence \mathbf{Y} of captured samples. Advantageously, this use of reliable symbols may be made non-invasive in that it can be employed without changing known adaptation and symbol decoding processes in prior art equalization systems.

Estimation of Channel Coefficients Based on Reliable Symbols and Reliability

By way of illustration, a way in which reliable symbols can be used in ISI coefficient estimation will now be described briefly. Consider the estimation of one-dimensional ISI coefficients. After a sufficient number of reliable and their related surrounding samples have been identified, the estimation of the ISI coefficients may be obtained as the solution of a standard matrix equation:

$$\hat{\underline{a}} = (\underline{H}^T \underline{H})^{-1} \underline{H}^T \underline{\delta} \tag{11}$$

where: $\hat{\underline{a}}$ is a vector of the ISI coefficient estimates; H is an NxM matrix, with $N \geq M$, in which each row contains the M surrounding symbol estimates or alternatively, the corresponding M surrounding sample values for each reliable symbol, and N is the number of related detected reliable symbols (a larger N is required for lower signal to noise ratios); and $\underline{\delta}$ is an N x 1 vector that contains the distances of the N reliable symbols from their estimated origin points.

By way of example, consider the following situation: The ISI length is assumed to have two coefficients ($K_1 = 0, K_2 = 2$) and the estimation is based on four reliable symbols. Let it be assumed that they correspond to time indexes: 100, 250, 300 and 320. Then,

$$\underline{\delta} = \{y_{100} - \hat{x}_{100}, y_{250} - \hat{x}_{250}, y_{300} - \hat{x}_{300}, y_{320} - \hat{x}_{320}\}^T \tag{12}$$

$$\underline{H} = \begin{Bmatrix} \hat{x}_{98}, \hat{x}_{99} \\ \hat{x}_{248}, \hat{x}_{249} \\ \hat{x}_{298}, \hat{x}_{299} \\ \hat{x}_{318}, \hat{x}_{319} \end{Bmatrix} \tag{13}$$

Optionally, however, the performance of the ISI adaptation can be improved by integrating a reliability weight factor into the calculation of ISI metrics. Consider the case of a subtractive equalizer. In such an equalizer, an adaptation unit 320 may estimate channel coefficients a_i and generate an estimate of source symbols according to equation 11 above.

In an embodiment, an estimate $\hat{\underline{a}}$ of \underline{a} may include a weighting based on reliabilities associated with received signal values. In this embodiment an estimate $\hat{\underline{a}}$ of \underline{a} may proceed according to:

$$\hat{\underline{a}} = (\underline{H}^T \underline{WH})^{-1} \underline{H}^T \underline{W\delta} \tag{14}$$

where \underline{W} is a diagonal $N \times N$ matrix of reliability weights $w_{i,i}$ ($w_{i,i} = 0$ for all $i \neq j$). In one such embodiment, the reliability weights $w_{i,i}$ may be obtained as:

$$w_{i,i} = f(R_i) \quad (15)$$

- 5 where R_i is the reliability factor associated with an i^{th} sample value, i being a member of the set of N sample values being used in the estimation process, and $f(\cdot)$ is a function that increases inversely with the associated reliability factor (e.g. as defined in equation 3).

10 Thus, symbols of varying degrees of reliability can be used with an appropriate reliability weighting.

In an embodiment, a destination may store captured samples in a buffer memory while reliable symbols are detected and while ISI estimation occurs. Thereafter, when the ISI metrics are available, the stored samples may be read from the memory and decoded. In this regard, provided the buffer memory is
15 appropriately sized, all captured samples may be decoded.

Estimation of Constellation Symbols In View of Channel Gain

Successful signal detection in communication systems requires a-priori knowledge of the location of the received constellation points. Hard-decision and soft-decision detection processes use a distance between a received signal point and its
20 associated received constellation point to decode symbols. Communication in the presence of an ISI channel results with the received extreme points being affected to such degree that they cannot be used simply to detect the position of the received constellation points. In fact, the received extreme points can reach as far as $1 + \sum_i |a_i|$
times their nominal distance from the origin. In addition, with gaussian noise from
25 other sources taken in account, this maximum distance from the origin can be increased further. The location of the received constellation points is the product of the location of transmitted constellation points and the channel gain.

In many communication applications, upon initial start up, a destination may have no a-priori knowledge of ISI coefficients ($a_i, i = -K_1$ to $K_2, i \neq 0$) and also no a priori
30 knowledge of the channel gain (a_0). Under this condition, the estimation of received constellation points may be carried out in two stages. In a first stage, an initial

estimation of the received constellation points may be made based on a small set of reliable symbols. In a second stage, a final estimation of received constellation points may be made using a larger set (possibly all) of the reliable symbols. These two stages are described below.

5 Initial Estimation of the Received Constellation Points

As described above, reliable symbols have the property that, when observed at the destination, they are closer to the source constellation point than to any other point in the constellation. This implies that the maximum distance from the reliable symbol to the source constellation point is at most half the distance between adjacent points in the received constellation.

The channel gain estimation may be made from reliable symbols. From a plurality of reliable symbols, those reliable symbols having the maximum magnitude along the constellation axes (e.g. the I and Q axes of a QAM constellation) may be chosen to be the initial maximum received constellation point in each axis. An initial constellation size may be determined from the magnitude of these maximally sized reliable symbols.

Let \hat{P}_1^{\max} be the initial estimation of the value of the maximum of the received constellation point along an axis. For a regular constellation, one having the same number of symbols in each axis, an initial estimation \hat{P}_1^1 of the received constellation is:

$$\hat{P}_1^q = \text{sign}(q) \cdot \frac{\hat{P}_1^{\max}}{\sqrt{M}-1} \cdot (2|q|-1) : q \in \left[\frac{-\sqrt{M}}{2}, \frac{\sqrt{M}}{2} \right] \quad (16)$$

where M is the number of points in the constellation and q is an integer index along an axis of the constellation. Equation 16 is appropriate for use when the constellation is square and the constellation points are regularly spaced. In general, when different symmetrical constellation shapes are used, the denominator in Equation 16 may be the number of constellation points for each axis, minus one, and q may be an appropriately valued index.

In an embodiment using an general constellation, the denominator in Equation 16 may be adjusted according to the number of constellation points for each axis:

$$\hat{P}_1^q = \text{sign}(q_J) \cdot \frac{\hat{P}_1^{\max}}{M_J - 1} \cdot (2|q_J| - 1) : q_J \in [-M_J, M_J] \quad (17)$$

where M_J is the number of points along the J^{th} axis of the constellation and q_J is the index along a J^{th} axis of the constellation.

Revising the Estimated Constellation Points

5 Returning to the regular case, an improved estimate, \hat{P}_2^q , can be obtained from:

$$\hat{P}_2^q = \hat{P}_1^q + (2|q| - 1) \cdot \hat{e}_1 : q \in \left[-\frac{\sqrt{M}}{2}, \frac{\sqrt{M}}{2}\right] \quad (18)$$

where,

$$\hat{e}_1 = \frac{1}{s} \sum_q \frac{1}{2|q| - 1} \cdot \sum_{n \in s_q} (\hat{P}_1^q - y_n^q) \quad (19)$$

10 and where s is the number of detected reliable symbols, s_q is a set of reliable symbols that are associated with the constellation point q as defined by Equation 18 and $\{y_n^q\}$ are the set of sample values which are reliable symbols and are associated with the q^{th} estimated constellation point. Equation 18 defines a set of constellation point estimates for use in channel gain estimation. The channel gain a_0 may be
 15 estimated as a ratio of the first constellation point estimate \hat{P}_2^1 to the magnitude of a smallest transmitted constellation point, e.g. +1. The estimation method described above can be generalized the situation in which the constellation may be non
 20 symmetrical and the separation between points may be non-uniform.

FIG. 10 is a block diagram of a receiver structure 500 according to an
 20 embodiment of the present invention. The receiver 500 may include a demodulator 510, a memory 520 and a processor 530. FIG. 10 illustrates communication flow among the demodulator 510, the memory 520 and the processor 530, not actual electrical interconnections among these units.

The demodulator 510 captures a signal \mathbf{Y} from the channel and generates
 25 captured samples y_n therefrom. The channel may be an electric, magnetic, acoustic, or optical propagation medium. Demodulators 510 for capturing such signals are

well-known. On account of the ISI, samples from the captured signal stream generally will have no detectable correspondence to the transmitted constellation. It may take any number of values between the constellation points (e.g. 6.3, 6.5, -3.1). Captured sample data may be stored in a buffer 522 in the memory 520.

5 The memory system 520 may be logically organized to perform storage functions that may be necessary for operation of the structure 500 as an equalizer. A first area 522 of the memory may store captured samples y'_n for further processing. This area may double as the frame memory 250 and buffer 270 illustrated in FIG. 2. A second area 524 of the memory may store the decoded symbols d_n . And, of course,
10 a third area of memory 526 may store program instructions. The memory system 520 may be populated by electric, magnetic or optical memories or other storage elements which may be configured as a read-only memory (ROM) or random access memory (RAM).

 As dictated by the instructions, operation of the processor 530 may be divided
15 into logical units such as a reliable symbol detector 532, an adaptation unit 534 and a symbol decoder 536. The processor 530 may be a general purpose processor, a digital signal processor, an application-specific integrated circuit or a collection of processing elements. The processor 530 may generate data representing estimated source symbols \hat{x}_n . These estimated source symbols may be output from the receiver
20 structure 500 or, in an alternate embodiment, be returned to the memory 520 in a decoded symbol buffer 524 to await further processing, or both.

 The foregoing discussion has presented techniques for identifying, from a sequence of captured samples, reliable symbols - samples that are likely to remain within the decision region of source symbols notwithstanding the presence of ISI
25 corruption. Further, various data decoding techniques have been presented that permit ISI estimation to be carried out based on the identified reliable symbols and, therefore, permits decoding of all captured samples to occur. Additionally, the reliable symbol techniques permit equalization to occur as a "blind" process, without requiring use of training symbols to estimate the channel effect. The inventors have
30 simulated transmission using 64-level QAM, 256-level QAM and 4096-level QAM. Use of these transmission constellations provides a 3 to 6-fold increase respectively in data transmission rates over 4-level QAM. Thus, the present invention contributes to

data transmission systems having increased throughput without incurring expense in communication bandwidth.

Although the foregoing discussion refers to intersymbol interference as a source of data corruption affecting a source signal X , application of the present invention is not so limited. The present invention finds application in any situation in which data correlated noise occurs. References herein to "ISI" should be so construed.

Several embodiments of the present invention are specifically illustrated and described herein. However, it will be appreciated that modifications and variations of the present invention are covered by the above teachings and within the purview of the appended claims without departing from the spirit and intended scope of the invention.

WE CLAIM:

1. A reliable symbol identification method comprising:
calculating a reliability factor of a candidate sample from values of a plurality of samples in proximity to the candidate sample,

5 if the reliability factor is less than a predetermined limit, designating the candidate sample as a reliable symbol.

2. The method of claim 1, wherein the reliability factor R_n of the candidate sample is given by:

$$R_n = \sum_{\substack{i=-K_1 \\ i \neq 0}}^{K_2} |y_{n-i}| \cdot c_i, \text{ where}$$

10 y_n is the candidate sample,
 y_{n-i} is a sample in proximity to the candidate sample,
 K_1, K_2 are numbers of samples adjacent to the candidate sample, and
 c_i is a coefficient.

3. The method of claim 2, where $c_i = 1$ for all i .

15 4. The method of claim 2, wherein $K_1 = 0$.

5. The method of claim 2, wherein $K_2 = 0$.

6. The method of claim 1, wherein the predetermined threshold varies over time.

7. The method of claim 1, further comprising determining a rate at which reliable symbols are identified, and

20 if the rate is less than a predetermined value, increasing the predetermined threshold.

8. The method of claim 1, further comprising determining a rate at which reliable symbols are identified, and

25 if the rate exceeds a second predetermined value, decreasing the predetermined threshold.

9. The method of claim 1, wherein the reliability of a two-dimensional candidate sample y_n is given by:

$$R_n = \sum_{\substack{i=-K_1 \\ i \neq 0}}^{K_2} \sqrt{y_{1n-i}^2 + y_{2n-i}^2} \cdot c_i, \text{ where}$$

y_{1n-i}^2 and y_{2n-i}^2 respectively represent values of a neighboring sample y_{n-i} in first and second dimensions,

K_1 , K_2 are numbers of samples adjacent to the candidate sample, and

c_i is a coefficient.

5

10. A method of identifying reliable symbols, comprising, for a candidate sample y_n :

iteratively, for $i = -K_1$ to K_2 , $i \neq 0$:

adding to a reliability factor based on a value of the sample y_{n-i} ,

10

if the reliability factor exceeds a predetermined limit, disqualifying the candidate sample as a reliable symbol, and

otherwise, incrementing i and, if $i=0$, re-incrementing i for a subsequent iteration;

thereafter, unless the candidate symbol has been disqualified, designating the candidate sample as a reliable symbol.

15

11. The method of claim 10, wherein the adding adds an absolute value of the sample y_{n-i} to the reliability factor.

12. The method of claim 10, wherein the adding adds a scaled value of the sample y_{n-i} to the reliability factor, the value scaled in accordance with a predetermined coefficient c_i .

20

13. The method of claim 10, wherein the adding adds the power of the sample y_{n-i} to the reliability factor.

14. The method of claim 10, wherein the predetermined limit is half a width of an annular constellation ring in which the candidate sample is observed.

25

15. The method of claim 10, wherein the predetermined limit is $(K_1 + K_2)d_{\min}$ where d_{\min} is half a distance between two constellation points that are closest together in a governing constellation.

16. The method of claim 10, wherein the predetermined limit varies over time.

17. The method of claim 10, further comprising determining a rate at which reliable symbols are identified, and
if the rate is less than a predetermined value, increasing the predetermined limit.
- 5 18. The method of claim 10, further comprising determining a rate at which reliable symbols are identified, and
if the rate exceeds a second predetermined value, decreasing the predetermined limit.
- 10 19. A method of identifying reliable symbols, comprising, for a candidate sample, determining whether any of a plurality of neighboring sample values is within a predetermined limit,
if none of the values exceed the threshold, designating the candidate sample as a reliable symbol.
20. The method of claim 19, wherein the predetermined limit varies over time.
- 15 21. The method of claim 19, further comprising determining a rate at which reliable symbols are identified,
if the rate is less than a predetermined threshold, increasing the predetermined limit.
- 20 22. The method of claim 21, further comprising, if the rate exceeds a second predetermined threshold, decreasing the predetermined limit.
23. The method of claim 19, wherein the neighboring samples occur in a first window adjacent to the candidate sample on one side of the candidate sample.
24. The method of claim 19, wherein the neighboring symbols occur in a pair of windows that are adjacent to, and on either side of the candidate sample.
- 25 25. A reliable symbol detection method, comprising:
identifying a sequence of signal values having values within a predetermined limit, and
designating a sample adjacent to the sequence as a reliable symbol.
26. The method of claim 25, wherein the predetermined limit varies over time.

27. The method of claim 25, further comprising determining a rate at which reliable symbols are identified,

if the rate is less than a predetermined threshold, increasing the predetermined limit.

5 28. The method of claim 27, further comprising, if the rate exceeds a second predetermined threshold, decreasing the predetermined limit.

29. A data decoder comprising:

a reliable symbol detector to detect reliable symbols from a sequence of captured samples, the captured samples having been corrupted by at least intersymbol interference ("ISI"),

10 an adaptation unit coupled to the reliable symbol detector to generate ISI metrics based on the reliable symbols, and

a data decoder to receive the captured samples and estimate source symbols based on the ISI metrics.

15 30. An equalization method, comprising

identifying reliable symbols from a string of captured samples,

calculating channel effects based on the reliable symbols and samples adjacent thereto,

correcting the captured samples based on the channel effects.

20 31. The method of claim 30, wherein the identifying comprises:

calculating a reliability factor of a candidate sample from values of a plurality of samples in the neighborhood of the candidate sample,

if the reliability factor is below a predetermined limit, designating the candidate sample as a reliable symbol.

25 32. The method of claim 31, wherein the reliability factor of the candidate sample y_n is given by:

$$R_n = \sum_{\substack{i=-K_1 \\ i \neq 0}}^{K_2} |y_{n-i}| \cdot c_i, \text{ where}$$

$y_{n,i}$ is a sample in the neighborhood of the candidate sample,

K_1 , K_2 are numbers of samples adjacent to the candidate sample, and

30 c_i is a coefficient.

33. The method of claim 31, wherein the reliability factor of the candidate sample y_n is given by:

$$R_n = \sum_{i=1}^K |y_{n-i}| \cdot c_i, \text{ where}$$

y_{n-i} is a sample in the neighborhood of the candidate sample,

5 K is a length of samples, and

c_i is a coefficient.

34. The method of claim 31, wherein the reliability of a two-dimensional candidate sample y_n is given by:

$$R_n = \sum_{\substack{i=-K_1 \\ i \neq 0}}^{K_2} \sqrt{y_{1-n-i}^2 + y_{2-n-i}^2} \cdot c_i, \text{ where}$$

10 y_{1-n-i}^2 and y_{2-n-i}^2 respectively represent values of a neighboring sample y_{n-i} in first and second dimensions,

K_1, K_2 are numbers of samples adjacent to the candidate sample, and

c_i is a coefficient.

35. The method of claim 30, wherein the identifying comprises:

15 identifying a sequence of samples having received signal magnitude levels below a predetermined limit, and

designating a sample adjacent to the sequence as a reliable symbol.

36. The method of claim 30, wherein, for QAM transmission, the identifying comprises:

20 identifying a sequence of samples for which a received signal magnitude in a quadrature-phase component is below a predetermined limit, and

designating an adjacent sample as a reliable symbol for quadrature-phase.

37. The method of claim 30, wherein, for QAM transmission, the identifying comprises:

25 identifying a sequence of samples for which a received signal magnitude in an in-phase component is below a predetermined limit, and

designating an adjacent sample as a reliable symbol for in-phase.

38. The method of claim 30, wherein the calculating estimates K channel coefficients a_i according to a least squared error analysis of $y_{RS} - \hat{x}_n - \sum_{i=1}^K \hat{a}_i \hat{x}_{n-i}$,

solving for \hat{a}_i , for a plurality of reliable symbols y_{RS} , where \hat{x}_n and \hat{x}_{n-i} are estimated transmitted symbols.

39. The method of claim 30, further comprising assigning weights among the reliable symbols based upon respective reliability factors.

5 40. An equalizer, comprising:
 a buffer memory,
 a reliable symbol detector in communication with the buffer memory,
 an adaptation unit in communication with the reliable symbol detector, and
 a symbol decoder in communication with the adaptation unit and the buffer
 10 memory.

41. The equalizer of claim 40, wherein the reliable symbol operates according to a method, comprising:

calculating a reliability factor of a candidate sample from values of a plurality of samples proximate to the candidate sample, and

15 if the reliability factor is less than a predetermined limit, designating the candidate sample as a reliable symbol.

42. The equalizer of claim 41, wherein the reliability factor R_n of the candidate sample is given by:

$$R_n = \sum_{\substack{i=-K_1 \\ i \neq 0}}^{K_2} |y_{n-i}| \cdot c_i, \text{ where}$$

20 y_n is the candidate sample,
 y_{n-i} is a sample in proximity to the candidate sample,
 K_1, K_2 are numbers of samples adjacent to the candidate sample, and
 c_i is a coefficient.

43. The equalizer of claim 41, wherein the reliability of a two-dimensional
 25 candidate sample y_n is given by:

$$R_n = \sum_{\substack{i=-K_1 \\ i \neq 0}}^{K_2} \sqrt{y_{1n-i}^2 + y_{2n-i}^2} \cdot c_i, \text{ where}$$

y_{1n-i}^2 and y_{2n-i}^2 respectively represent values of a neighboring sample y_{n-i} in first and second dimensions,

K_1, K_2 are numbers of samples adjacent to the candidate sample, and c_i is a coefficient.

44. A receiver, comprising:

a demodulator,

5 a buffer memory in communication with the demodulator,

a processor in communication with the demodulator, executing instructions that establish the following logical structures therein:

a reliable symbol detector in communication with the buffer memory,

an adaptation unit in communication with the reliable symbol detector,

10 and

a symbol decoder unit in communication with the adaptation unit and the buffer memory, and

a source decoder in communication with the equalizer.

45. The receiver of claim 44, wherein the reliable symbol operates according to a method, comprising:

15

calculating a reliability factor of a candidate sample from values of a plurality of samples proximate to the candidate sample, and

if the reliability factor is less than a predetermined limit, designating the candidate sample as a reliable symbol.

20 46. The receiver of claim 45, wherein the reliability factor R_n of the candidate sample is given by:

$$R_n = \sum_{\substack{i=-K_1 \\ i \neq 0}}^{K_2} |y_{n-i}| \cdot c_i, \text{ where}$$

y_n is the candidate sample,

y_{n-i} is a sample in proximity to the candidate sample,

25

K_1, K_2 are numbers of samples adjacent to the candidate sample, and c_i is a coefficient.

47. The receiver of claim 45, wherein the reliability of a two-dimensional candidate sample y_n is given by:

$$R_n = \sum_{\substack{i=-K_1 \\ i \neq 0}}^{K_2} \sqrt{y_{1-n-i}^2 + y_{2-n-i}^2} \cdot c_i, \text{ where}$$

y_{1n-i}^2 and y_{2n-i}^2 respectively represent values of a neighboring sample y_{n-i} in first and second dimensions,

K_1 , K_2 are numbers of samples adjacent to the candidate sample, and c_i is a coefficient.

5 48. The receiver of claim 44, further comprising a second buffer memory in communication with the symbol decoder.

49. A transmission system comprising:

a source that transmits data encoded as symbols, the symbols being selected from a high-order constellation,

10 a destination that captures a signal representing the transmitted symbols having been corrupted by at least intersymbol interference, the destination:

identifying reliable symbols from the captured samples,

calculating channel effects based on the reliable symbols and samples proximate thereto,

15 correcting other captured samples based on the channel effects.

50. The method of claim 49, wherein reliable symbols are identified according to a method comprising:

calculating a reliability factor of a candidate sample from values of a plurality of samples proximate to the candidate sample, and

20 if the reliability factor is less than a predetermined limit, designating the candidate sample as a reliable symbol.

51. The method of claim 50, wherein the reliability factor R_n of the candidate sample is given by:

$$R_n = \sum_{\substack{i=-K_1 \\ i \neq 0}}^{K_2} |y_{n-i}| \cdot c_i, \text{ where}$$

25 y_n is the candidate sample,

y_{n-i} is a sample in proximity to the candidate sample,

K_1 , K_2 are numbers of samples adjacent to the candidate sample, and

c_i is a coefficient.

52. The method of claim 50, wherein the reliability of a two-dimensional candidate sample y_n is given by:

$$R_n = \sum_{\substack{i=-K_1 \\ i \neq 0}}^{K_2} \sqrt{y_{1-n-i}^2 + y_{2-n-i}^2} \cdot c_i, \text{ where}$$

y_{1-n-i}^2 and y_{2-n-i}^2 respectively represent values of a neighboring sample y_{n-i} in first

5 and second dimensions,

K_1 , K_2 are numbers of samples adjacent to the candidate sample, and c_i is a coefficient.

53. A computer readable medium having stored thereon instructions that, when executed, cause a processor to:

10 calculate a reliability factor of a candidate sample from values of a plurality of samples proximate to the candidate sample, and

if the reliability factor is less than a predetermined limit, designate the candidate sample as a reliable symbol.

54. The method of claim 53, wherein the reliability factor R_n of the candidate
15 sample is given by:

$$R_n = \sum_{\substack{i=-K_1 \\ i \neq 0}}^{K_2} |y_{n-i}| \cdot c_i, \text{ where}$$

y_n is the candidate sample,

y_{n-i} is a sample in proximity to the candidate sample,

K_1 , K_2 are numbers of samples adjacent to the candidate sample, and

20 c_i is a coefficient.

55. The method of claim 53, wherein the reliability of a two-dimensional candidate sample y_n is given by:

$$R_n = \sum_{\substack{i=-K_1 \\ i \neq 0}}^{K_2} \sqrt{y_{1-n-i}^2 + y_{2-n-i}^2} \cdot c_i, \text{ where}$$

y_{1-n-i}^2 and y_{2-n-i}^2 respectively represent values of a neighboring sample y_{n-i} in first

25 and second dimensions,

K_1 , K_2 are numbers of samples adjacent to the candidate sample, and c_i is a coefficient.

56. A computer readable medium having stored thereon instructions that, when executed, cause a processor to:

identify reliable symbols from a string of captured samples,
calculate channel effects based on the reliable symbols and samples proximate

5 thereto,

correct the captured samples based on the channel effects.

57. A data signal, generated according to the process of:

identifying reliable symbols from a string of captured samples,
calculating channel effects based on the reliable symbols and samples

10 proximate thereto,

estimating transmitted symbols from remaining captured samples based on
the channel effects, and

outputting the estimated symbols as the data signal.

58. A channel gain estimation method, comprising:

15 identifying reliable symbols from a sequence of captured data samples,
estimating a constellation size from a set of maximally-sized reliable symbols.

59. The channel gain estimation method of claim 58, further comprising
estimating constellation points \hat{p}^q within a square constellation with uniformly
separated points according to:

20
$$\hat{p}_1^q = \text{sign}(q) \cdot \frac{\hat{p}_1^{\max}}{\sqrt{M} - 1} \cdot (2|q| - 1), \text{ where}$$

\hat{p}_1^{\max} represents the estimated constellation size,

M represents an order of the constellation, and

q is an index provided along an axis of the constellation.

60. The channel gain estimation method of claim 58, further comprising

25 estimating constellation points $\hat{p}_{1_j}^q$ within a general constellation according to:

$$\hat{p}_{1_j}^q = \text{sign}(q_j) \cdot \frac{\hat{p}_{1_j}^{\max}}{M_j - 1} \cdot (2|q_j| - 1), \text{ where}$$

$\hat{p}_{1_j}^{\max}$ represents the estimated constellation size along a J^{th} axis,

M_j represents an order of the constellation along the J^{th} axis, and

q_j is an index provided along along the J^{th} axis of the constellation.

61. The channel gain estimation method of claim 58, further comprising revising the estimate of the constellation size based on additional reliable symbols.

62. The channel gain estimation method of claim 61, wherein the revising comprises estimating a second set of constellation points \hat{P}_2^q according to:

5
$$\hat{P}_2^q = \hat{P}_1^q + (2|q| - 1) \cdot \hat{e}_1, \text{ where}$$

$$\hat{e}_1 = \frac{1}{s} \sum_q \frac{1}{2|q| - 1} \cdot \sum_{n \in S_q} (\hat{P}_1^q - y_n^q),$$

$$\hat{P}_1^q = \text{sign}(q) \cdot \frac{\hat{P}_1^{\max}}{\sqrt{M} - 1} \cdot (2|q| - 1),$$

10 \hat{P}_1^{\max} represents the estimated value of the magnitude of the maximum constellation point,

M represents an order of the constellation,

s is a number of detected reliable symbols,

S_q is a set of reliable symbols that are associated with the constellation point q,

15 $\{y_n^q\}$ are the set of sample values which are reliable symbols that are associated with the q^{th} estimated constellation point.. and
 q is an index provided along an axis of the constellation.

63. A reliable symbol identification method comprising:

calculating a reliability factor of a candidate sample from constellation points nearest to each of a plurality of samples in proximity to the candidate sample,

20 if the reliability factor is less than a predetermined limit, designating the candidate sample as a reliable symbol.

64. The method of claim 63, wherein the reliability factor R_n of the candidate sample is given by:

$$R_n = \sum_{\substack{i=-K_2 \\ i \neq 0}}^{K_2} |p_{n-i}| \cdot c_i, \text{ where}$$

25 p_{n-i} is the value of a constellation point nearest to the sample y_{n-i} which is in proximity to the candidate sample y_n ,

K_1, K_2 are numbers of samples adjacent to the candidate sample, and

c_i is a coefficient.

65. The method of claim 63, wherein the reliability of a two-dimensional candidate sample y_n is given by:

$$R_n = \sum_{\substack{i=-K_1 \\ i \neq 0}}^{K_2} \sqrt{p_{1_{n-i}}^2 + p_{2_{n-i}}^2} \cdot c_i, \text{ where}$$

$p_{1_{n-i}}$ and $p_{2_{n-i}}$ respectively represent first and second dimensional values of a

5 constellation point nearest to $y_{n,i}$ which is in proximity to the candidate sample y_n ,
 K_1 , K_2 are numbers of samples adjacent to the candidate sample, and
 c_i is a coefficient.

66. The method of claim 63, further comprising, for any samples having similar reliability factors, prioritizing the samples based on the samples' values.

10 67. The method of claim 63, further comprising, for any sample having a reliability factor that is less than the predetermined limit, comparing the sample's value against a second threshold and, if the value exceeds the threshold, disqualifying the sample as a reliable symbol.

15 68. The method of claim 63, further comprising, for any samples having similar reliability factors, prioritizing the samples based on values of constellation points nearest to the samples.

20 69. The method of claim 63, further comprising, for any sample having a reliability factor that is less than the predetermined limit, comparing a value of a constellation point nearest to the sample to a second threshold and, if the value exceeds the threshold, disqualifying the sample as a reliable symbol.

70. A method of identifying reliable symbols, comprising, for a candidate sample y_n :

iteratively, for $i = -K_1$ to K_2 , $i \neq 0$:

25 adding to a reliability factor a value derived from a constellation point nearest to a sample $y_{n,i}$,

if the reliability factor exceeds a predetermined limit, disqualifying the candidate sample as a reliable symbol, and

otherwise, incrementing i and, if $i=0$, re-incrementing i for a subsequent iteration;

thereafter, unless the candidate symbol has been disqualified, designating the candidate sample as a reliable symbol.

71. The method of claim 70, wherein the adding adds a scaled value of the constellation point to the reliability factor, the value scaled in accordance with a
5 predetermined coefficient c_j .

72. The method of claim 70, the predetermined limit is $(K_1 + K_2)d_{\min}$ where d_{\min} is half a distance between two constellation points that are closest together in a governing constellation.

73. The method of claim 70, wherein the predetermined limit is the product of
10 $K_1 + K_2$ and half the width of an annular constellation ring associated with the candidate symbol.

74. A method of identifying reliable symbols, comprising, for a candidate sample, determining whether any of a plurality of constellation points each associated with sample neighboring the candidate sample is within a predetermined threshold,
15 if none of the constellation points exceed the threshold, designating the candidate sample as a reliable symbol.

75. The method of claim 74, wherein the neighboring samples occur in a first window adjacent to the candidate sample on one side of the candidate sample.

76. The method of claim 74, wherein the neighboring samples occur in a pair of
20 windows that are adjacent to, and on either side of the candidate sample.

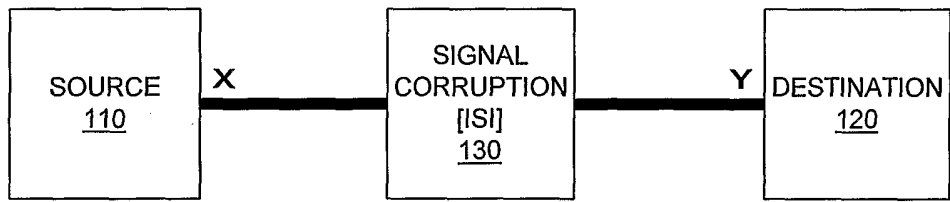

FIG. 1
100

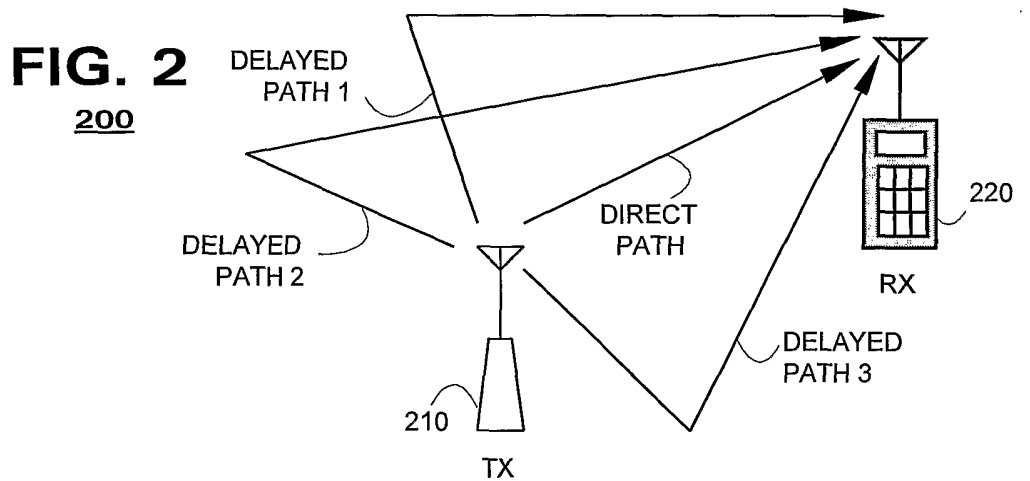

FIG. 2
200

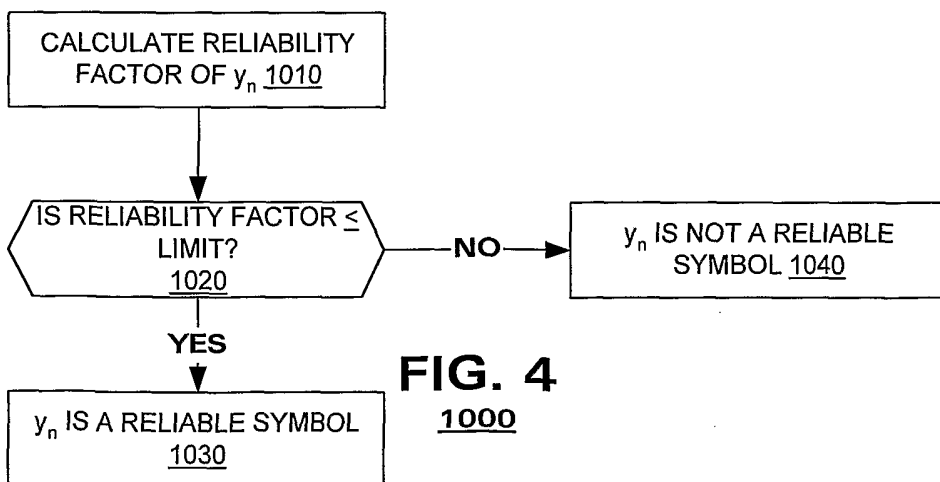
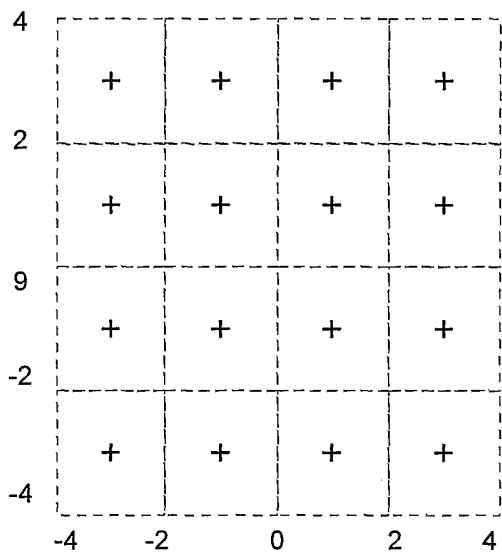
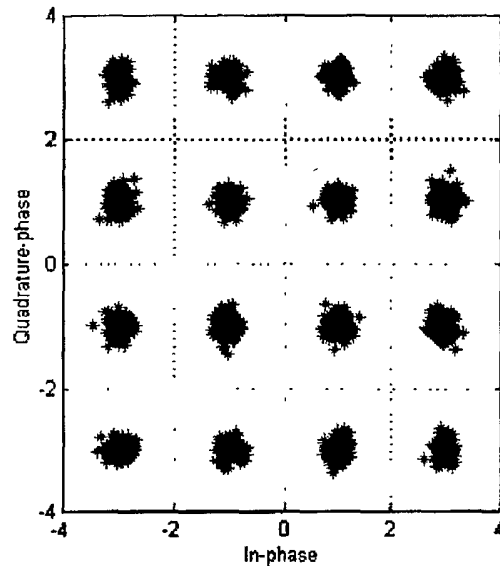

FIG. 4
1000



(a)



(b)

FIG. 3

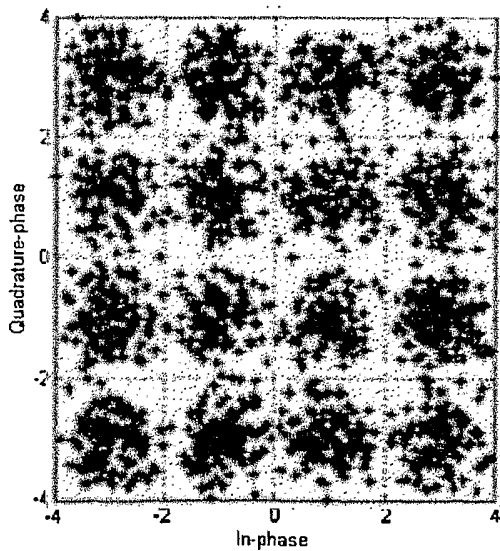

(c)

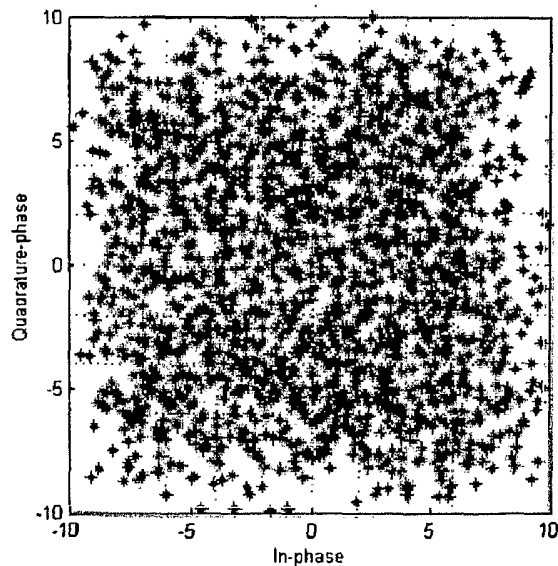

(d)

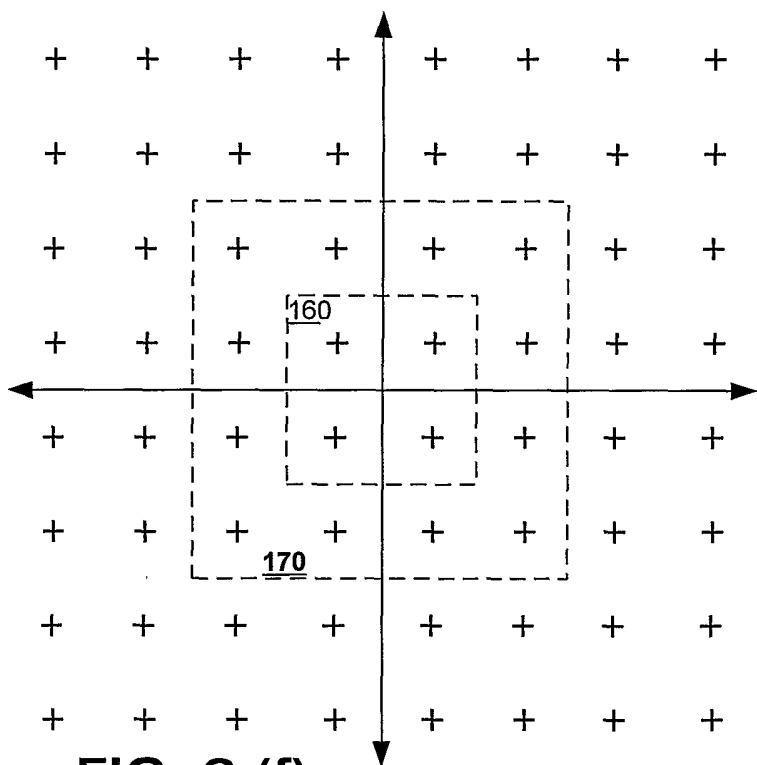

FIG. 3 (f)

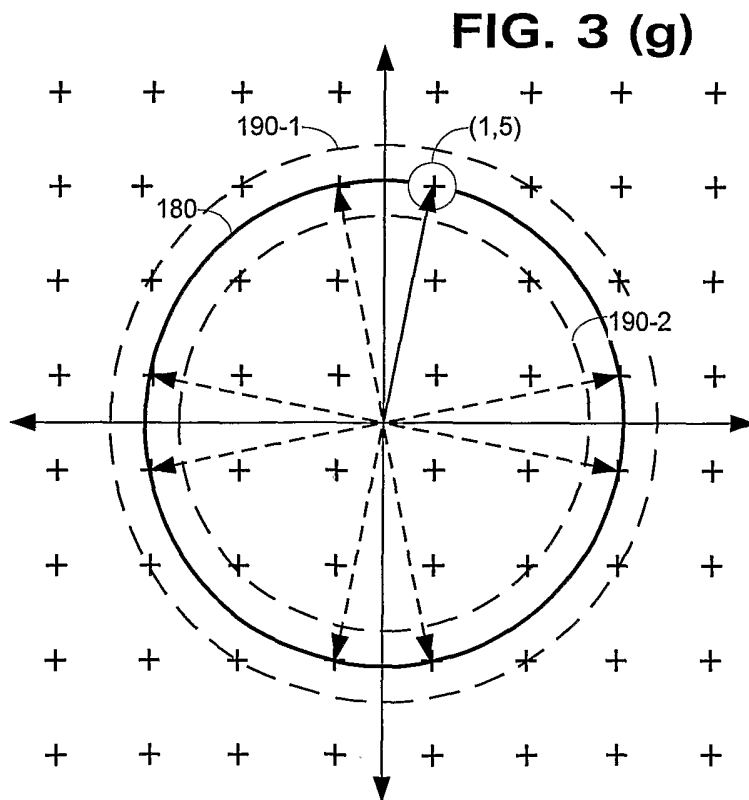
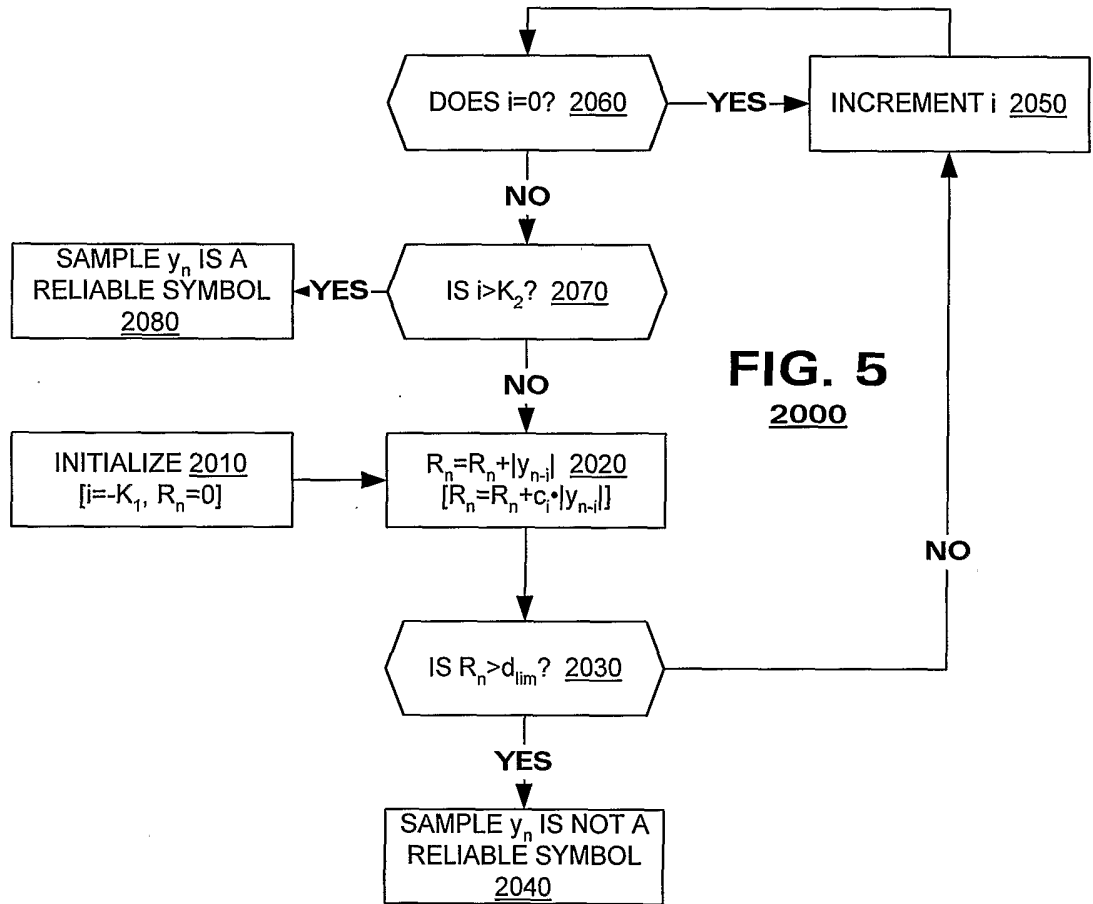
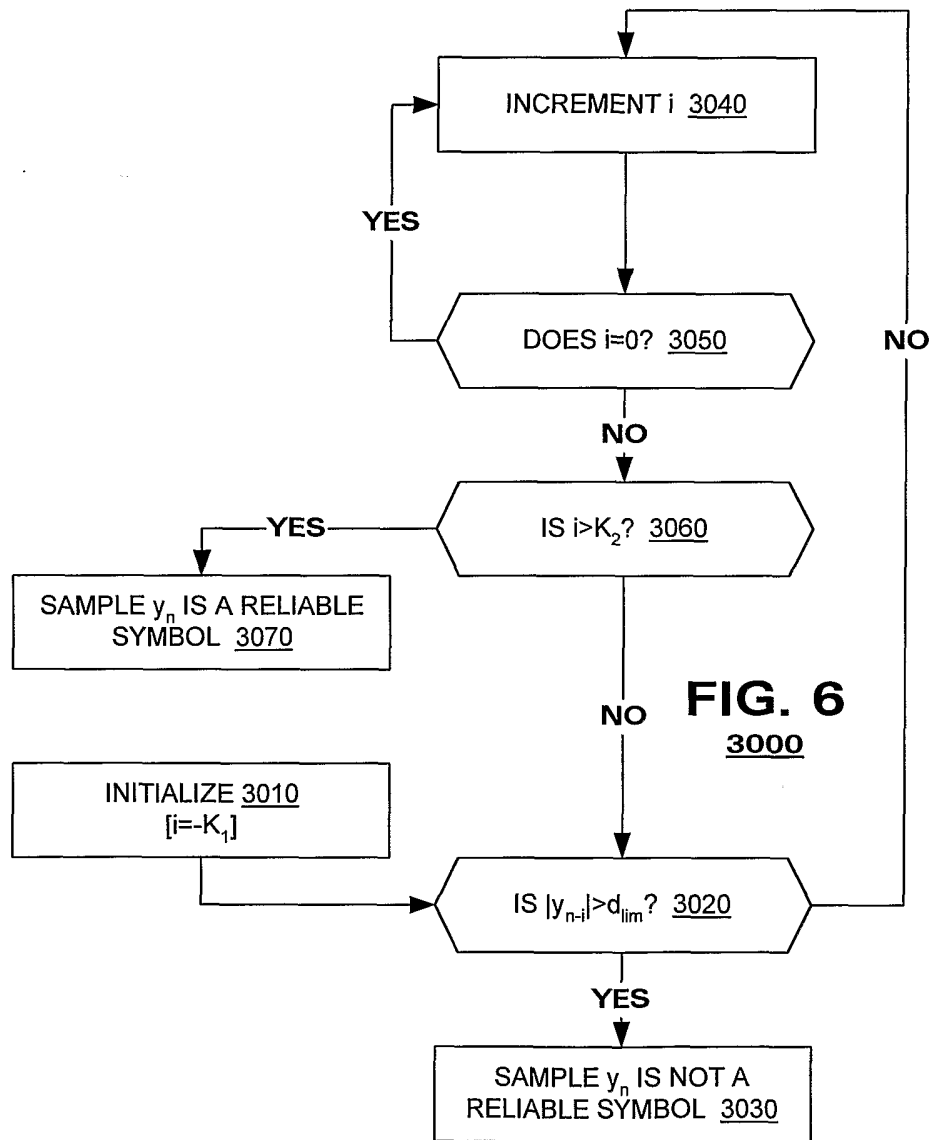

FIG. 3 (g)





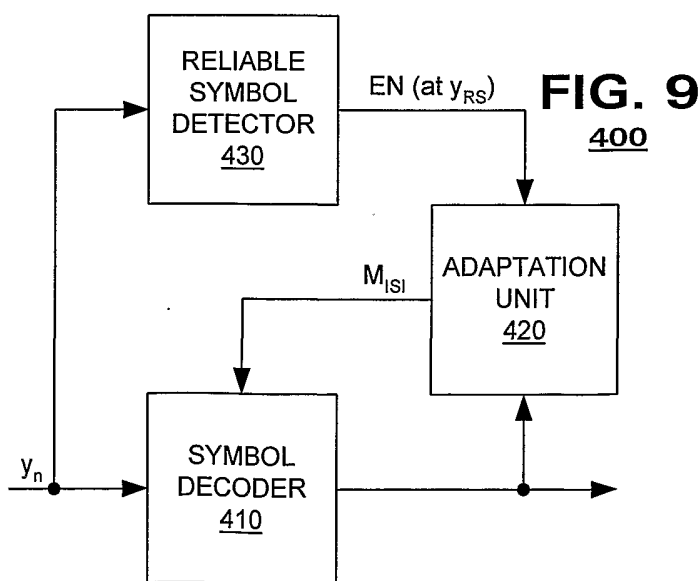
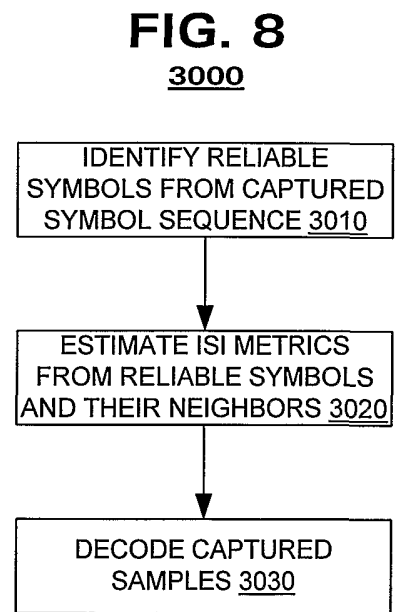
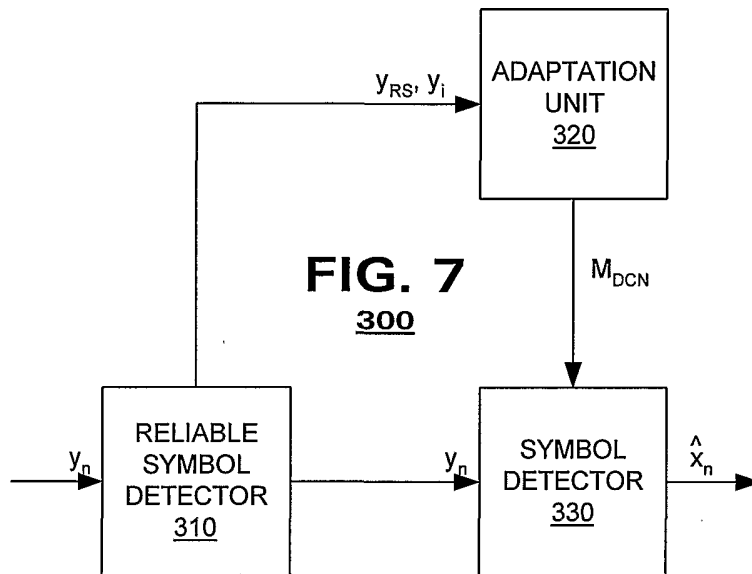

FIG. 10
500

