

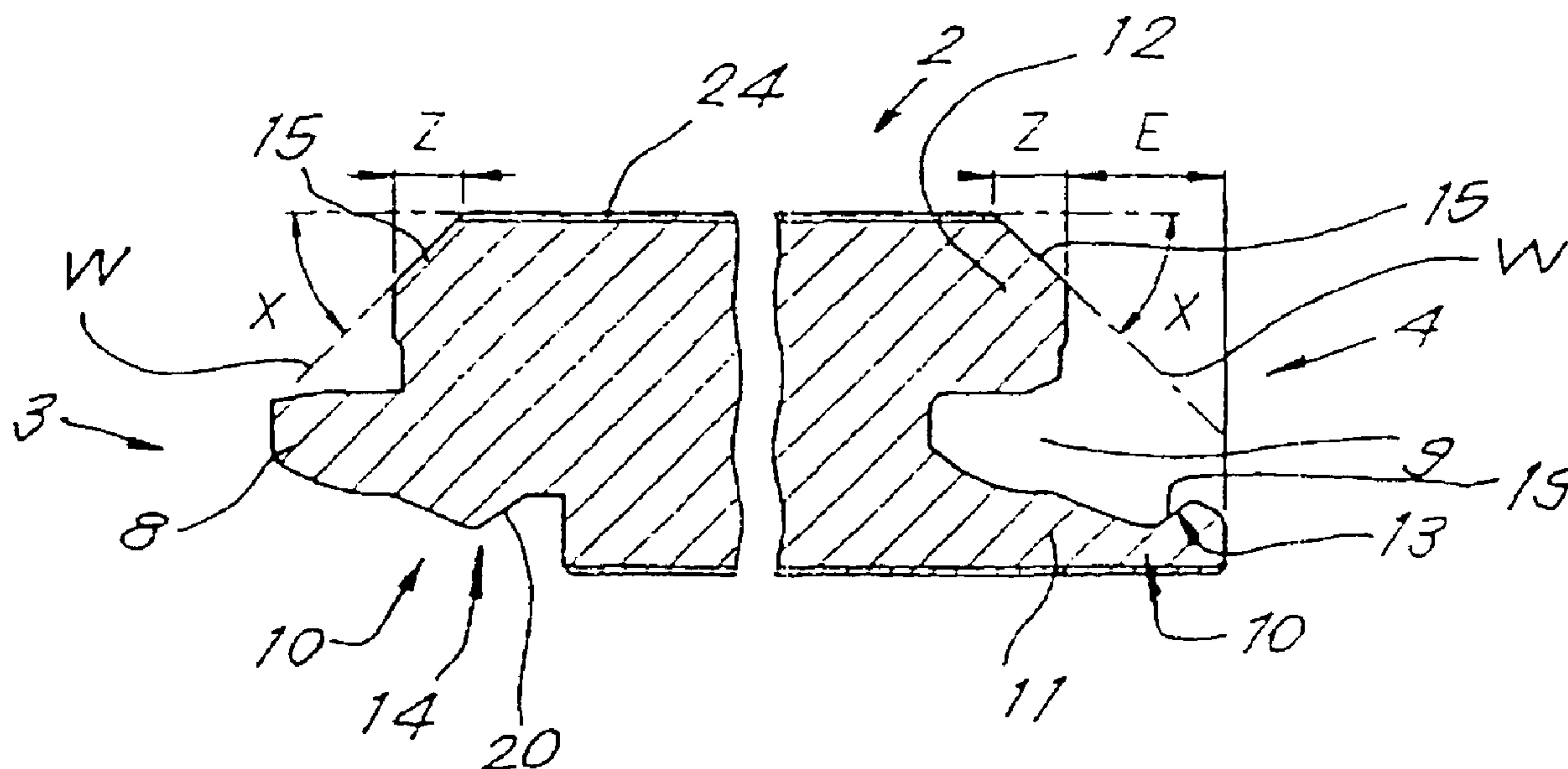

(22) Date de dépôt/Filing Date: 2001/01/12  
 (41) Mise à la disp. pub./Open to Public Insp.: 2001/12/20  
 (62) Demande originale/Original Application: 2 410 206  
 (30) Priorité/Priority: 2000/06/13 (BE20000381)

(51) Cl.Int./Int.Cl. *E04F 15/00* (2006.01),  
*E04C 2/40* (2006.01), *E04F 15/022* (2006.01)  
 (71) Demandeur/Applicant:  
FLOORING INDUSTRIES LTD., IE  
 (72) Inventeur/Inventor:  
THIERS, BERNARD PAUL JOSEPH, BE  
 (74) Agent: ROBIC

(54) Titre : REVETEMENT DE SOL  
 (54) Title: FLOOR COVERING



(57) **Abrégé/Abstract:**

Floor covering consisting of hard panels (2), whereby these panels (2) are provided, at least on two opposite edges (3-4; 5-6), with coupling means (7) made in one piece with the panels (2), so that several of such panels (2) can be mutually coupled, whereby these coupling means (7) provide for an interlocking in a direction (R1) perpendicular to the plane of the floor covering (1), as well as in a direction (R2) perpendicular to the edges (3-4; 5-6) concerned and parallel to the plane of the floor covering (1), and whereby these coupling means (7) are made such that the panels (2) can be rotated into and/or out of one another at least along the above-mentioned edges (3-4; 5-6), characterised in that the panels (2) are provided, at least on the above-mentioned edges (3-4; 5-6), near the top side, with a part from which has been removed an amount of material.

**ABSTRACT**

Floor covering consisting of hard panels (2), whereby these panels (2) are provided, at least on two opposite edges (3-4; 5-6), with coupling means (7) made in one piece with the panels (2), so that several of such panels (2) can be mutually coupled, whereby these coupling means (7) provide for an interlocking in a direction (R1) perpendicular to the plane of the floor covering (1), as well as in a direction (R2) perpendicular to the edges (3-4; 5-6) concerned and parallel to the plane of the floor covering (1), and whereby these coupling means (7) are made such that the panels (2) can be rotated into and/or out of one another at least along the above-mentioned edges (3-4; 5-6), characterised in that the panels (2) are provided, at least on the above-mentioned edges (3-4; 5-6), near the top side, with a part from which has been removed an amount of material.

Floor covering.

5 The present invention concerns a floor covering, in particular of the type consisting of hard panels.

In a particular, yet not restrictive manner, it concerns a floor covering formed of laminate panels, also called  
10 laminate parquet.

It is known that such laminate panels can be made of different layers. Usually, the panels are formed of boards on the basis of wood, such as chipboard or fibreboard, in particular MDF or HDF, upon which one or several layers,  
15 including a decorative layer, are provided at least on the top side. The decorative layer may be a printed paper layer, but in certain embodiments it may just as well be a layer of wood, in particular veneer. Such panels can also  
20 be made of other materials, for example merely synthetic material, or of a base plate on the basis of wood, such as chipboard, MDF or HDF and the like, upon which is provided, instead of a printed paper layer or veneer, another material such as cork, thin strips of wood and the like.

25

It is also known to couple these panels on their edges as they are laid, either by means of a conventional tongue and groove joint, whereby they are possibly glued together, either by means of a glueless coupling which provides for a  
30 mutual interlocking of the panels both in the horizontal

and vertical direction, for example as described in international patent No. WO 97/47934.

The present invention aims a floor covering of hard panels, in particular laminate panels, which provides for new embodiments according to different aspects offering respective-advantages.

According to the present invention, there is also provided a floor covering panel comprising a top side, at least two opposite edges including coupling elements made in one piece with the panel and arranged so that several ones of such panels can be mutually coupled to form a floor covering;

10       said coupling means arranged to enable an interlocking of two of said panels in a direction perpendicular to a plane including the panels, as well as in a direction perpendicular to the respective edges and parallel to the plane including the panels;

      said panel comprising at least a core upon which is provided a decorative imprinted layers;

      said coupling means being formed in one piece with the core layer and being of the type which consist of a tongue, a groove and locking means;

      said locking means, in a coupled condition of two of said panels, ensuring at least said interlocking in a direction perpendicular to the edges of said panels  
20       and parallel to the plane including said panels;

      wherein said panel at least on said two opposite edges, near said top side, is provided with parts from which has been removed an amount of material;

      wherein each of said parts extends from said top side, through said decorative imprinted layer and through the material of the core;

      said coupling elements being formed such that two of said panels can be coupled to one another by means of a rotation movement, wherein during said rotation movement a contact zone is present between the concerned edges, and

2a

such that said panels, in a coupled condition, fit into one another free from play or practically free from play.

As material parts have been removed from the top edge, this offers several advantages. A first advantage consists in that the panels, as they are rotated, both when rotating into one another and when rotating out of one another, can be moved more easily in relation to one another, as there are no angular parts anymore which hinder the mutual rotation of the panels. A second advantage

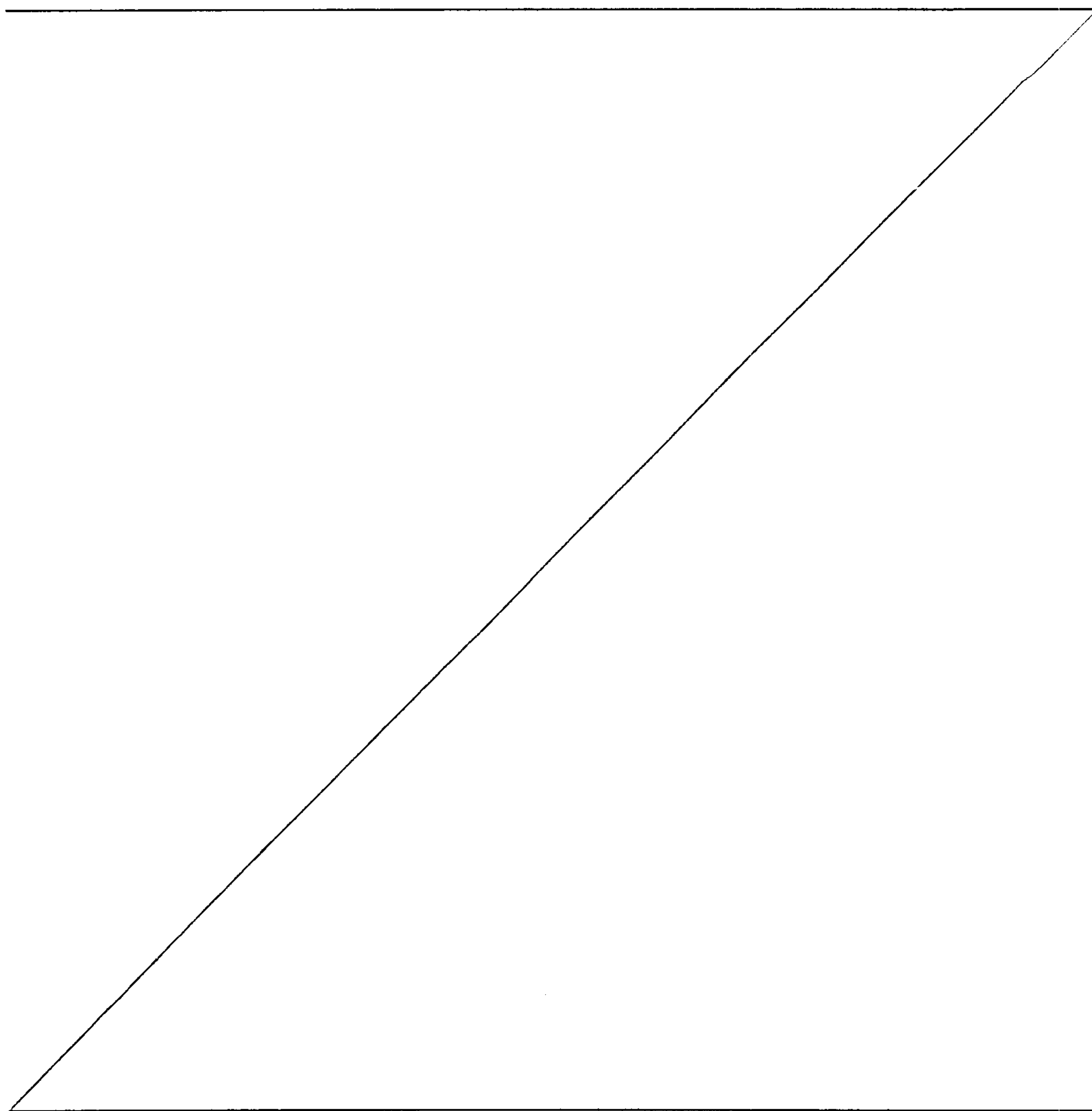

consists in that the panels can be made heavier, in particular thicker than as usual, as the thickness of the panels, thanks to the bevel, has little or no influence anymore on the good working order of the above-mentioned coupling means, during the rotating in and/or the rotating out.

Preferably, the above-mentioned parts consist of bevels, in particular with a gradient of  $45^\circ$ . Practically, the bevels preferably extend, in a horizontal direction, over a distance of at least 1 millimeter. Preferably, however, this distance is in the order of magnitude of 2 millimeter.

10 Preferably, according to a different variant of the first aspect of the invention, the coupling means are made such that the panels, instead of being disconnectable at least by a rotation, can be disconnected from one another at least in one other manner. Even then, the above-mentioned bevel still offers certain advantages, as will become clear from the further description.

According to the most preferred embodiment, the panels are rectangular and are provided with the above-mentioned parts, that is, the above-mentioned bevels, respectively, on all four-sides.

20 Preferably, according to a second aspect which can either or not be combined with the first aspect, the invention provides for a floor covering consisting of hard panel with a core upon which is provided a panel decorative layer, whereby these panels are rectangular and elongated and are provided with coupling means at least on the two opposite longitudinal

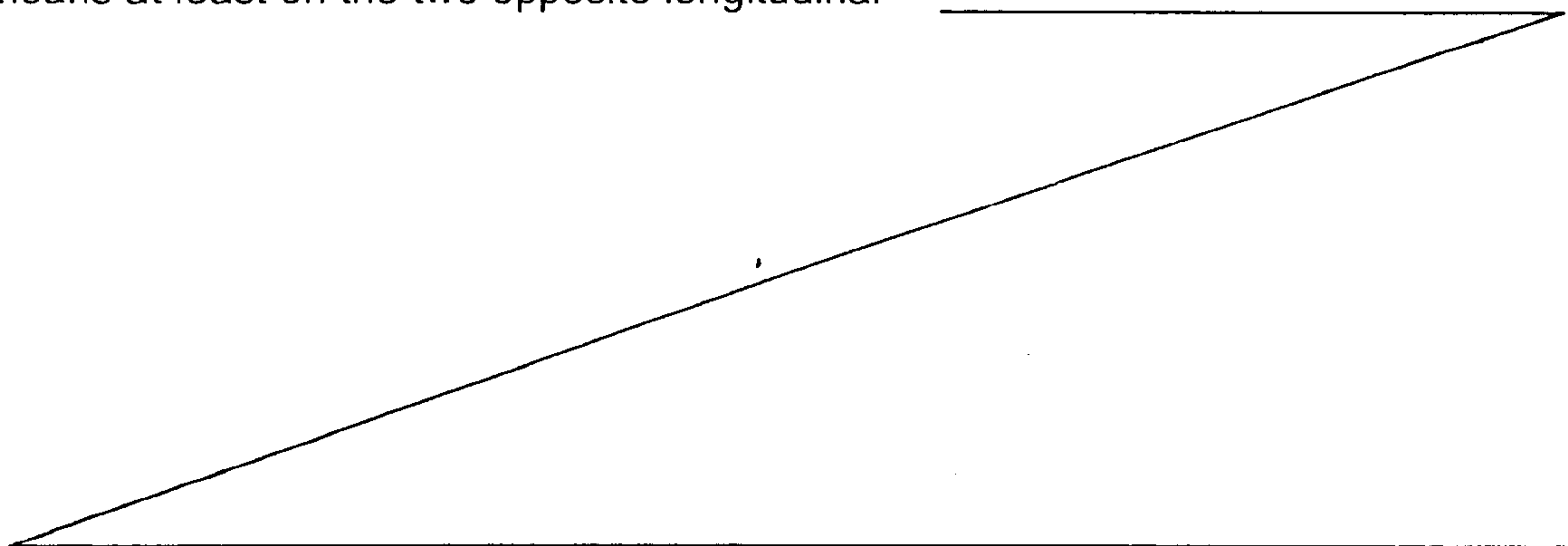

edges, so that several of such panels can be mutually coupled to one another, whereby these coupling means provide for an interlocking in a direction perpendicular to the plane of the floor covering, as well as in a direction perpendicular to the edges concerned and parallel to the plane of the floor covering, and whereby these coupling means are made such that the panels can be coupled and/or uncoupled by means of a rotation along their longitudinal edge, characterised in that the width of the panels is smaller than 17 cm, and preferably even smaller than 16 cm.

Further, these panels, apart from the above-mentioned maximum width, preferably have a length which amounts to at least eight times the width.

It is known that hard panels, which are equipped with coupling means which provide for a horizontal and a vertical interlocking on at least two of their edges, are made as relatively small plates with a width of 19 to 20 cm and a length of 1.20 to 1.40 m. It is also known that the plates, when being laid, have to be occasionally rotated into one another and out of one another so as to make them fit against a wall, skirting board or the like. A disadvantage of the known embodiments of the above-mentioned plates consists in that it is often difficult to carry out said rotation, for example when the plates have to be installed with their far ends under the edge of an overhanging cupboard or such. According to the above-mentioned second aspect of the invention, this disadvantage, as well as others, are excluded, if not minimised. Thanks to the small width, the panels are less

high when being rotated, so that there are no disadvantages during the installation in a large number of practical applications.

Moreover, the above-mentioned relation between length and width offers a technical solution, as a result of which the visual "plate-like" effect is excluded.

Preferably, according to a third aspect of the invention, it provides for a floor covering consisting of hard panels, with a laminated structure, having a decorative layer on the top surface, characterised in that bevels or such are formed on one or several edges of the panels, near the top side, and in that the surface of these bevels or such is also provided with a decorative layer, preferably a layer provided as separate. In particular, such a layer preferably consists of a separately provided print. Thanks to the use of such a separate print, the bevels can be easily provided with a decorative surface. The base panels can then be realised in a conventional manner by sawing them out of a large plate which has already been provided with a decorative layer, whereas the bevels are printed later.

Preferably, according to a major embodiment of the third aspect, the above-mentioned print consists of a print which is obtained by means of transfer printing. Such transfer printing offers the advantage, in combination with its use on floor panels, that high production rates can be obtained and that any pattern whatsoever can be realized. Further, this technique excludes the risk of the decorative top surface

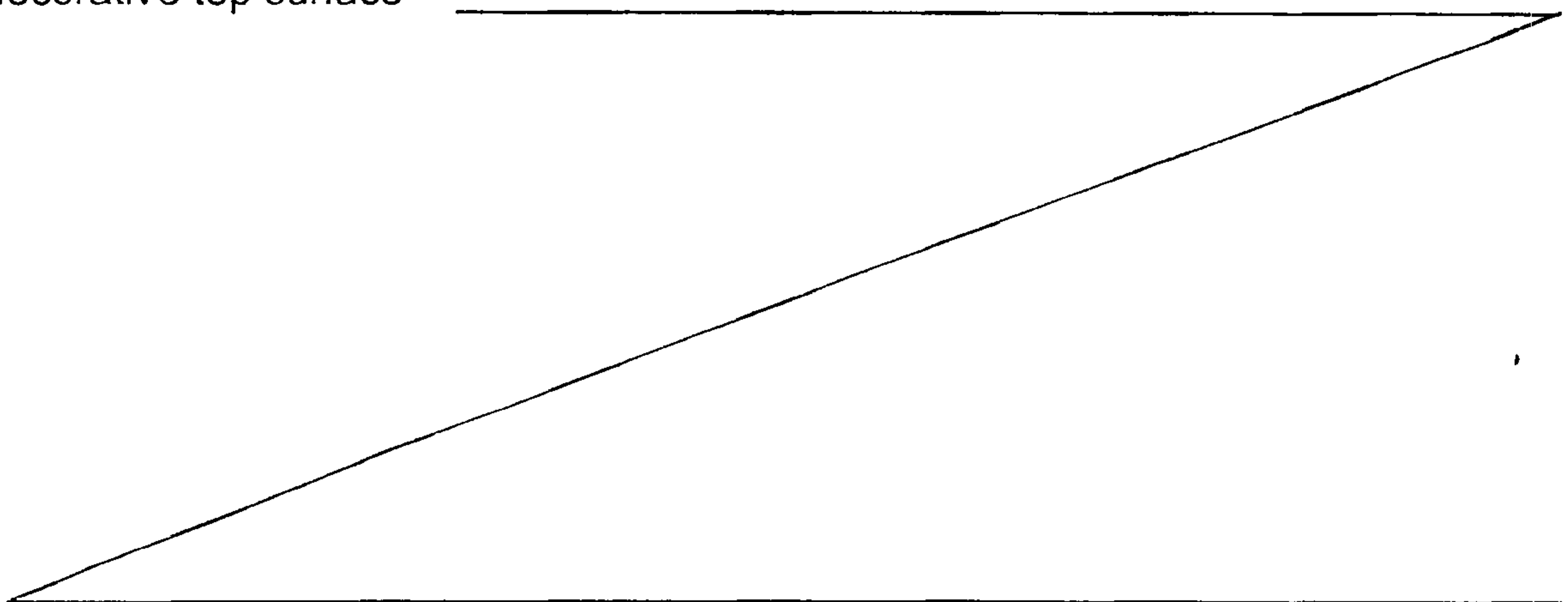



of the panels being soiled. Another major advantage hereby consists in that the print is immediately or almost immediately dry, so that the panels can be stacked and packed almost immediately.

5

Preferably, the floor panels, which are made according to the third aspect of the invention, have a core made of a material on the basis of wood, in particular wood which has been ground into particles or fibres, mixed with a binding agent, upon which the decorative layer is provided, and whereby the above-mentioned bevels extend through the material of the core. Thus is obtained a porous surface on the bevels, guaranteeing a good bond of the print.

15 As usual, the decorative layer preferably contains a layer printed with a pattern, such as a wood pattern, and the decorative layer according to the invention, in particular the print on the bevels or such, is preferably realised with a similar pattern.

20

Moreover, use is preferably made of a moisture-proof, impermeable decorative layer or print respectively, which is particularly advantageous in case the panels have a base plate which consists of porous material, such as MDF, HDF or the like. Thus is obtained an entirely moisture-proof structure on the top surface, on the flat surface by means of the usual layer of synthetic material on the one hand, and on the bevels by means of the additional decorative layer situated on the bevel on the other hand.

30

Although the decorative layer on the bevels is preferably realised by means of transfer printing, other possibilities are not excluded. Thus, for example, use can be made of a self-adhesive strip.

Preferably, according to a fourth aspect, the invention provides for a floor covering, consisting of hard panels with a core on the basis of MDF or HDF, or a similar material, characterised in that the panels are each separately provided with an underlayer provided on the bottom side and fixed onto it, preferably made of polyethylene or on the basis of polyethylene. The combination of MDF or HDF with the use of an underlayer fixed onto it, especially when it is formed of polyethylene or is made on the basis of polyethylene, offers the advantage that particularly good sound-insulating qualities are obtained.

Preferably, the present invention concerns embodiments applying only one of the above-mentioned aspects as well as embodiments in which two or several of the above-mentioned aspects are combined. In this respect it should be noted that two or several of the above-mentioned embodiments can be mutually combined at random, in any possible combination, provided these embodiments have no contradictory qualities.

Although, according to some of the above-mentioned aspects, the panels may consist of different sorts of material, the invention is particularly suitable for panels made of MDF or HDF, or a similar material.

According to a preferable embodiment, the panels have a thickness of 9 mm at the least, and better still of 10 mm at the least, as opposed to the usual thickness of 7 or 8 mm.

Thus are obtained relatively heavy panels, which consequently have a better sound-insulating effect, as a result of which less sound is produced when they are walked on.

In so far as coupling means as mentioned above are used which allow for a glueless interlocking, they can be of different nature. Thus, these coupling means can show one of the following characteristics or a combination of two or several of them:

- that they are provided on two opposite edges of the panels;
- that they are provided on panels which are rectangular, whereby they are provided on both pairs of opposite edges;
- that at least for a number of the edges they allow for an assembly according to one of the following possibilities:
  - at least by shifting the panels towards one another;
  - exclusively by shifting the panels towards one another;
  - at least by rotating the panels along the edges concerned;
  - exclusively by rotating the panels along the edges concerned;

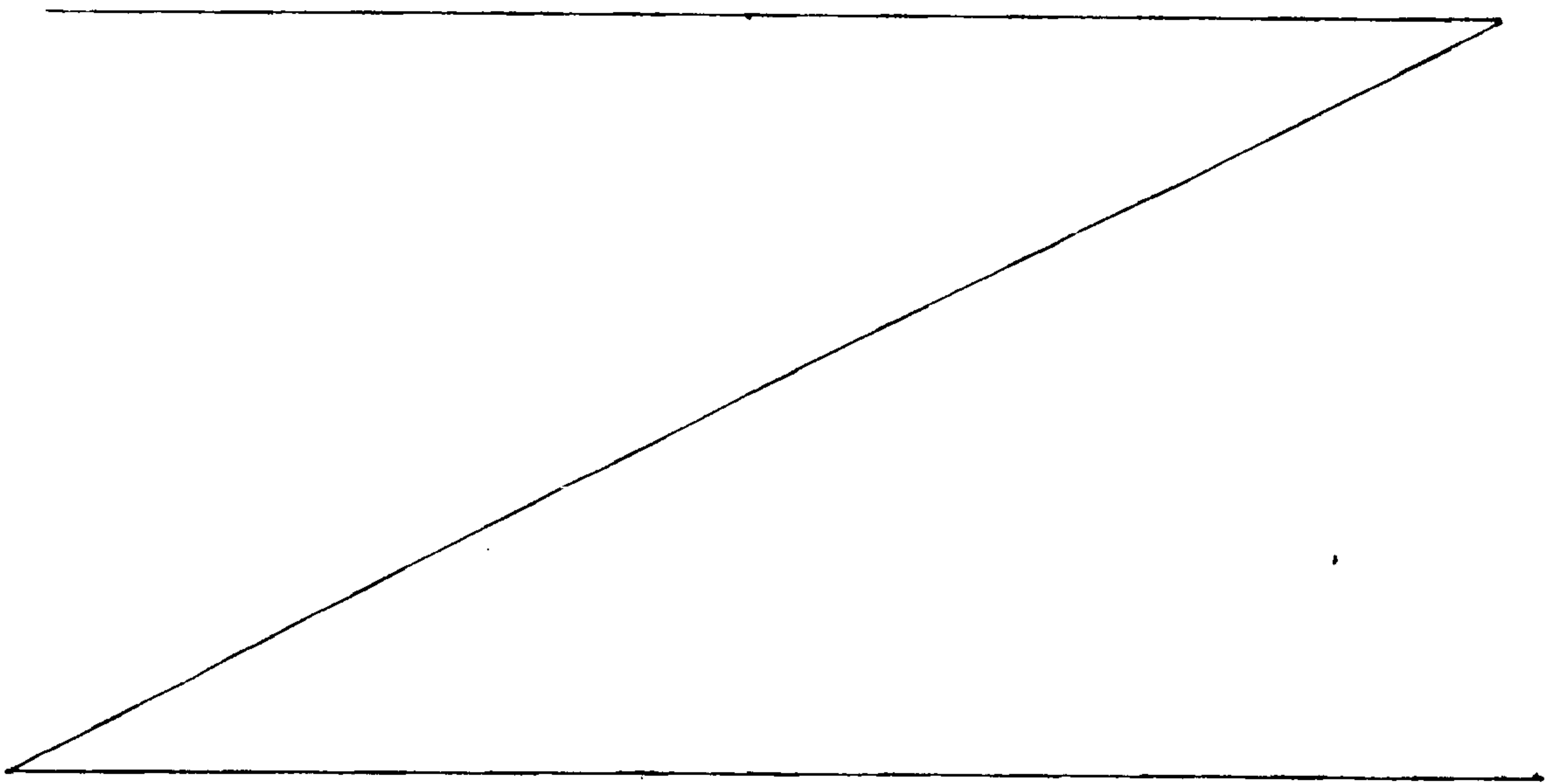

- 9 -

- by shifting the panels towards one another or by rotating them, as desired;
- that, at least for a number of the edges, they allow for an uncoupling according to any of the following possibilities:
  - at least by shifting the panels out of one another in a direction perpendicular to the edges;
  - exclusively by shifting the panels out of one another in a direction perpendicular to the edges;
  - 10 - at least by rotating the panels along the edges concerned;
  - exclusively by rotating the panels along the edges concerned;
  - by shifting the panels out of one another as well as  
15 by rotating them;
- that they are of the type which consists of a tongue and a groove on the one hand, and of locking means which ensure at least a specific interlocking in a direction perpendicular to the edges of the coupled panels and  
20 parallel to the plane of the panels on the other hand;
- that they are realised as in the preceding paragraph, whereby the lip which limits the bottom side of the groove, seen from a cross section, extends past the upper lip, and whereby the locking means consist of one  
25 or several parts on the lip limiting the bottom side of the groove on the one hand, and of one or several parts on the bottom side of the tongue working in conjunction with the latter on the other hand;
- that the above-mentioned tongue and groove are made such  
30 that when two of such panels are freely shifted towards

- 10 -

one another, over a base or such, the tongue automatically ends up in the groove;

- that they are formed such that the panels, when coupled, fit into one another without any play or almost without any play.

Naturally, the invention also concerns panels with which the above-described floor coverings can be realised.

In order to better explain the characteristics of the invention, the following preferred embodiments are described as an example only without being limitative in any way, with reference to the accompanying drawings, in which:

15

figure 1 schematically represents a part of a floor covering which is built up of panels according to the invention;

figure 2 represents a top view of a panel from the floor covering of figure 1;

figures 3 and 4 represent sections, according to lines III-III and IV-IV respectively in figure 2;

figure 5 represents a section according to line V-V in figure 1 to a larger scale;

figure 6 represents a section according to line VI-VI in figure 1 to a larger scale;

figure 7 represents the part indicated by F7 in figure 6 to a larger scale;

figure 8 shows a view analogous to that in figure 7, but whereby the panels are mainly shifted towards one another in one and the same plane;

- 11 -

figure 9 shows a section of another panel according to the invention, with bevels which are provided with a print;

5 figure 10 schematically represents how the print can be provided in the embodiment of figure 9;

figure 11 schematically represents a section according to line XI-XI in figure 10;

figure 12 represents a section of another panel according to the invention.

10

As represented in figures 1 and 2, the invention concerns a floor covering 1 as well as hard panels 2 from which such a floor covering 1 is built up.

15 According to a first aspect of the invention, a floor covering 1 is concerned, consisting of hard panels 2, whereby these panels 2 are provided at least on two opposite edges 3-4, and preferably, as represented in the figures 2 to 8, on both pairs of edges 3-4, 5-6  
20 respectively, with coupling means 7 made in one piece out of the material of the panels 2, so that several of such panels 2 can be mutually coupled to one another, whereby these coupling means 7 provide for an interlocking in a direction R1 perpendicular to the plane of the floor  
25 covering 1, as well as in a direction R2 perpendicular to the edges 3-4 or 5-6 concerned and parallel to the plane of the floor covering 1, and whereby these coupling means 7 are made such that the panels 2 can be assembled and/or disassembled at least along the above-mentioned edges 3-4,  
30 5-6 respectively, by means of a rotation.

- 12 -

Such coupling means 7, which make it possible to couple the panels 2 without any glue being required, at least on two sides and preferably on all sides, and whereby the panels 2 are uncoupled by rotating them out of one another, are  
5 known as such from international patent No. 97/47834.

From WO 97/47834 it is also known that the above-mentioned coupling means 7, as represented in figures 3 to 8 of the present application, may consist of a tongue 8 and a groove  
10 9 on the one hand, and of locking means 10 on the other hand which at least ensure a specific interlocking in a direction perpendicular to the edges 3-4, 5-6 respectively, of the coupled panels 2 and parallel to the plane of these panels 2. As is further represented, these coupling means  
15 7 are moreover preferably made such that the lip 11 which limits the bottom side of the groove 9, seen from a cross section, extends past the upper lip 12, while the locking means 10 are formed of interlocking parts 13-14 working in conjunction, on the above-mentioned lip 11 which limits the  
20 bottom side of the groove 9 and on the bottom side of the coupled panel 2 respectively, in particular the bottom side of the tongue 8 or the extension of this bottom side.

As explained in WO 97/47834, such coupling means 7,  
25 depending on their embodiment, allow for different couplings. According to the most preferred embodiment, they are, as will be described hereafter by means of figure 1, made such that they allow for a coupling by rotating into one another as well as by shifting towards one  
30 another. The latter allows such panels to be coupled by first rotating them into one another on their edges 3-4, as

- 13 -

represented by the panel 2A in figure 1, with a rotation  
W1, and by subsequently snapping them together on their  
edges 5-6 by means of a translation T1. According to a  
variant, the connection on the edges 3-4 of the panels  
5 concerned can also be realised by starting from a position  
as is schematically indicated with reference 2B, and by  
coupling the panel concerned by means of a translation T2.

The above-mentioned rotation is further illustrated in  
10 figures 6 and 7, whereas the sliding motion is represented  
in figure 8. Hereby should be noted that the tongue 8 and  
groove 9 are preferably made such that, as is also  
represented in figure 8, when two such panels 2 are freely  
shifted towards one another over a bottom or such, the  
15 tongue 8 automatically ends up in the groove 9.

It is also possible, while holding a panel 2A in a rotated  
position, to couple a following panel 2C onto it on the  
edges 5 and 6 concerned, either by means of a translation  
20 T3, or by a mutual rotation between the panels 2A and 2C,  
after which both panels 2A and 2C are then rotated down to  
be interlocked with the preceding row of panels.

Another advantage consists in that a glueless coupling  
25 without any play or practically without any play remains  
possible, also with thicker panels which can be rotated  
into and/or out of one another, without any extreme  
compression forces being created on the edge parts during  
the rotation. The bevels makes sure that such forces are  
30 excluded and/or remain limited, so that the risk of



- 14 -

damages, among others to the top layer or to the surface of the bevels, are excluded, if not restricted.

What makes the first aspect of the invention special is  
5 that the above-mentioned panels 2 are provided, at least on two of their edges 3-4 or 5-6, and preferably on all four edges 3 to 6, near the top side, with a part from which an amount of material has been removed, which part preferably each time consists of a bevel 15.

10

As represented in figures 6 and 7, these bevels 15 among others offer the advantage that the panels 2 can be easily rotated in relation to one another, as the material parts 16 and 17 which are otherwise present no longer press onto  
15 one another, and a contact zone 18 is obtained which is situated relatively low.

Another advantage consists in that when it is required for the above-mentioned interlocking parts 13 and 14, in  
20 particular the accompanying contact surfaces 19 and 20, to extend tangentially or almost tangentially around a circle having the contact zone 18 as its centre, the average gradient A of the contact surfaces can be kept relatively large for a same distance E of the protruding part of the  
25 lower lip 11, as indicated in figure 5, as a result of which a solid interlocking can be ensured, even with thicker panels 2.

Another advantage consists in that, irrespective of the  
30 thickness D of the panels 2, the contact zone 18 can always be situated at a certain height H above the bottom side of

the panels 2, provided the bevels 15 are realised over an appropriate height H1. Thus it is possible, if required, to always work with similar cutting tools to form the tongue 8 and groove 9, for thinner as well as for thicker panels 2.

Although the above-mentioned advantages are particularly felt with embodiments of the type whereby the uncoupling of the panels 2 can be realised by means of a rotation around the above-mentioned contact zone 18, it should be noted that the above-mentioned bevels 15 also offer advantages which do not necessarily coincide with the fact whether it is either or not possible for the panels 2 to be disassembled by means of rotation. Such bevels 15 offer the advantage that the panels 2 never press directly onto one another on their top surface, so that damage of the top layer resulting from mutual contact between the panels 2 is excluded, which is particularly important in the case of laminate parquet, as well as for floor coverings which are connected without any glue and whereby the panels are driven into one another by means of a hammer and a stop block.

Also, according to a different embodiment, the first aspect of the invention no longer merely applies to panels 2 which can be disassembled by means of a rotation, but it also applies to all sorts of panels 2 which are provided with coupling means 7 which make it possible for the panels 2 to be interlocked both vertically and horizontally on their edges 3-4, 5-6 respectively, irrespective of whether the

- 16 -

assembly and/or disassembly has to be or can be realised by means of a rotation or sliding motion.

The above-mentioned bevels 15 preferably extend at an angle X of 45° in relation to the plane which is determined by the panels 2. However, other gradients are not excluded.

Practically, the bevels 15 will extend in a horizontal direction over a distance Z in the order of magnitude of 2 millimetre, although other dimensions are not excluded here either.

As is further represented in figure 5, lateral surfaces, in particular contact surfaces 21-22 are present under the above-mentioned bevels 15, which fit up to one another at least at the top when the panels 2 are coupled, and thus form a mutual stop.

It is clear that the first aspect of the invention can be applied with panels 2 having an elongated design, as represented in figure 2, as well as with panels 2 having a square design.

According to the above-mentioned second aspect of the invention, which in the given example of figures 1 and 2 is combined with the above-mentioned first aspect, but which can also be realised as separate from the first aspect, the invention concerns a floor covering 1, consisting of hard panels 2 having a core 23 and a decorative upper surface 24, whereby these panels 2 are rectangular and elongated and are provided with coupling means 7 on at least two

opposite longitudinal edges 3-4 and/or 5-6; as a result of which several of such panels 2 can be mutually coupled to one another, whereby these coupling means 7 are provided with an interlocking in a direction perpendicular to the plane of the floor covering 1, as well as in a direction perpendicular to the edges 3-4-5-6 concerned and parallel to the plane of the floor covering, and whereby these coupling means 7 are made such that the panels 2 can be coupled and/or uncoupled by means of a rotation along their longitudinal edges 3-4 and/or 5-6, characterised in that the useful width B of the panels 2 is smaller than 17 cm, and preferably amounts to 15.5 cm.

Such a narrow width B, combined with coupling means 7 of the type whereby the uncoupling has to be carried out by rotating the panels 2 in relation to one another, as represented in figure 6, offers the advantage that the height H2 over which the panel 2 to be uncoupled has to be rotated before it is detached, also remains relatively small, as a result of which the disadvantage mentioned in the introduction is minimised.

Moreover, the panels 2, according to the second aspect of the invention, preferably also have a length L which amounts to at least eight times the width B.

Preferably, the panels 2 made according to the second aspect of the invention, also have a single pattern which is repeated over the entire top surface, in particular a wood pattern.

- 18 -

Figure 9 illustrates the third aspect of the invention. According to this third aspect, the invention concerns a floor covering 1 consisting of hard panels 2 with a laminated structure, having a decorative layer 25 on the top surface, characterised in that bevels 15 or such are formed on one or several edges 3 to 6 of the panels 2, near the top side, and in that the surface of these bevels 15 or such is also provided with a decorative layer, in this case a print 26, which is preferably obtained as a print layer has been provided on this surface by means of transfer printing.

The decorative layer 25 may as such consist of several layers, but it preferably contains at least one layer imprinted with a pattern, for example a wood pattern printed on a paper layer. In this case, the print 26 can be realised on the bevels 15 or such with a similar pattern. As a printing technique is applied for the decorative layer as well as for the print 26, it is very easy to match both patterns as far as colour and/or design are concerned.

As mentioned in the introduction, the print 26 is preferably moisture-proof, impermeable respectively. Thus is obtained a sealing on the bevels 15, which is particularly useful when the panels have a porous core, for example made of MDF or HDF.

Figures 10 and 11 schematically represent how the print 26 can be provided on the surface 27 by means of transfer printing. A support 28 which is provided with a printing

layer 29 is put into contact with the surface 27 and is applied with a preferably heated press-on roller 30, as a result of which the printing layer 29 adheres to the material of the panel 2 and comes off the support 28, so that the above-mentioned print 26 is created. The support 28 with the printing layer 29 is hereby supplied as of a roller 31, whereas said support 28, after the printing layer 29 has been transferred to the surface 27, is rolled up on a roller 32.

10

Other transfer printing techniques which are known as such are not excluded, however.

It should be noted that, both as far as the above-mentioned first aspect and the third aspect are concerned, according to a preferred embodiment, one or several, and preferably all bevels 15 extend at such an angle that the extension, determined by said bevel 15, is situated outside the contour of the panel 2 or just touches it, as indicated by the lines W in figures 3, 4 and 10. This is advantageous in that, both when the bevels 15 are applied and when the print 26 is applied, these bevels 15 are easily accessible to the machine parts used thereby.

25

According to a fourth aspect of the invention, it concerns a floor covering consisting of hard panels 2 with a core 23 on the basis of MDF or HDF, or a similar material, characterised in that the panels 2 are each separately provided with an underlayer 36 made of synthetic material or another dampening or insulating material provided on the

30

bottom side and fixed onto it, preferably made of polyethylene or on the basis of polyethylene, as represented in figure 12. The combination of these materials offers the advantage that little sound is produced when these panels 2 are walked on.

The above-mentioned underlayer 36 can be fixed to the bottom side of the panel 2 in any way whatsoever, for example by means of gluing or by melting it onto it. In the case of a conventional laminate construction, the structure thus consists of the decorative layer 25, the core 23, usually on the basis of MDF or HDF, a counterlayer 37, and the above-mentioned underlayer 36.

It is clear that the fourth aspect of the invention can be used in combination with floor panels which are provided with a conventional tongue and groove on their edges, as well as in combination with floor panels with coupling means which provide for a horizontal and a vertical interlocking, for example coupling means 7 as described above.

The invention is by no means limited to the above-described embodiments represented in the accompanying drawings; on the contrary, such a floor covering, and in particular the above-mentioned panels, can be made in all shapes and dimensions while still remaining within the scope of the invention.

**WHAT IS CLAIMED IS:**

1. A floor covering panel comprising a top side, at least two opposite edges including coupling elements made in one piece with the panel and arranged so that several ones of such panels can be mutually coupled to form a floor covering;

said coupling means arranged to enable an interlocking of two of said panels in a direction perpendicular to a plane including the panels, as well as in a direction perpendicular to the respective edges and parallel to the plane including the panels;

said panel comprising at least a core upon which is provided a decorative imprinted layers;

said coupling means being formed in one piece with the core layer and being of the type which consist of a tongue, a groove and locking means;

said locking means, in a coupled condition of two of said panels, ensuring at least said interlocking in a direction perpendicular to the edges of said panels and parallel to the plane including said panels;

wherein said panel at least on said two opposite edges, near said top side, is provided with parts from which has been removed an amount of material;

wherein each of said parts extends from said top side, through said decorative imprinted layer and through the material of the core;

said coupling elements being formed such that two of said panels can be coupled to one another by means of a rotation movement, wherein during said rotation movement a contact zone is present between the concerned edges, and such that said panels, in a coupled condition, fit into one another free from play or practically free from play.

2. The floor covering panel of claim 1, wherein said parts are cut-away portions.



3. The floor covering panel according to claim 1 or 2; wherein said parts are formed as bevels.
4. The floor covering panel according to claim 3, wherein said bevels extend at an angle of 45° in relation to the plane which is determined by the panels.
5. The floor covering panel according to claim 3 or 4, wherein said bevels, in the horizontal direction, extend over a distance in the order of magnitude of 2 millimetres.
6. A floor covering panel according to any one of claims 1 to 4, wherein in a coupled condition of two of said panels, lateral contact surfaces are situated  
10 under said parts which, fit up to one another at least near their top sides.
7. The floor panel covering panel according to any one of claims 1 to 5, wherein said contact zone is located at least 1 millimeter below said panel layer.
8. The floor covering panel according to any one of claims 1 to 6, wherein said panels are rectangular and wherein said parts are provided on all four sides.
9. The floor covering panel according to any one of claims 1 to 7, wherein said floor covering panel is a laminate floor covering panel and wherein said decorative imprinted layer contains a paper layer and the top surface of said panel is formed of synthetic material.
- 20 10. The floor covering panel according to any one of claims 2 to 8, wherein one or several, and preferably all bevels extend at such an angle that the extension which is determined by these bevels is situated outside the contour of the section of the panel or just touches it.

11. The floor covering panel according to any one of claims 2 to 9, wherein said bevels extend in a horizontal direction over a distance of at least 1 millimetre.

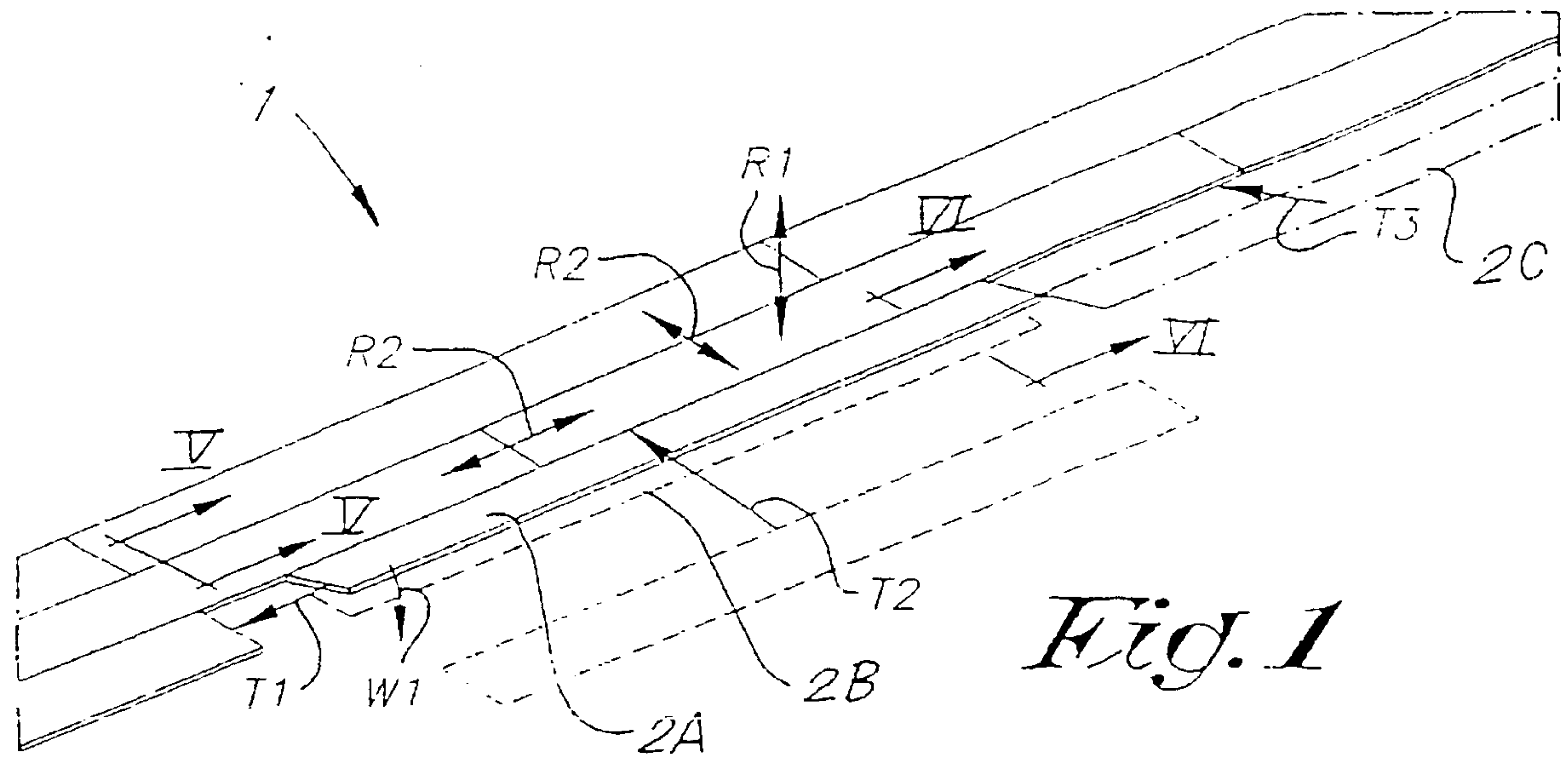

*Fig. 1*

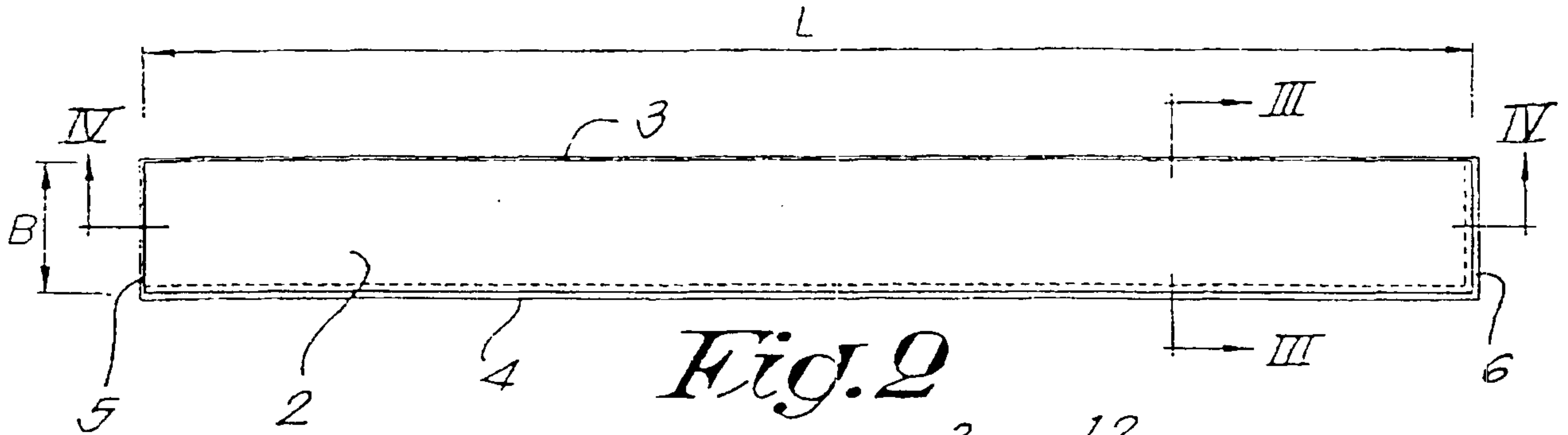

*Fig. 2*

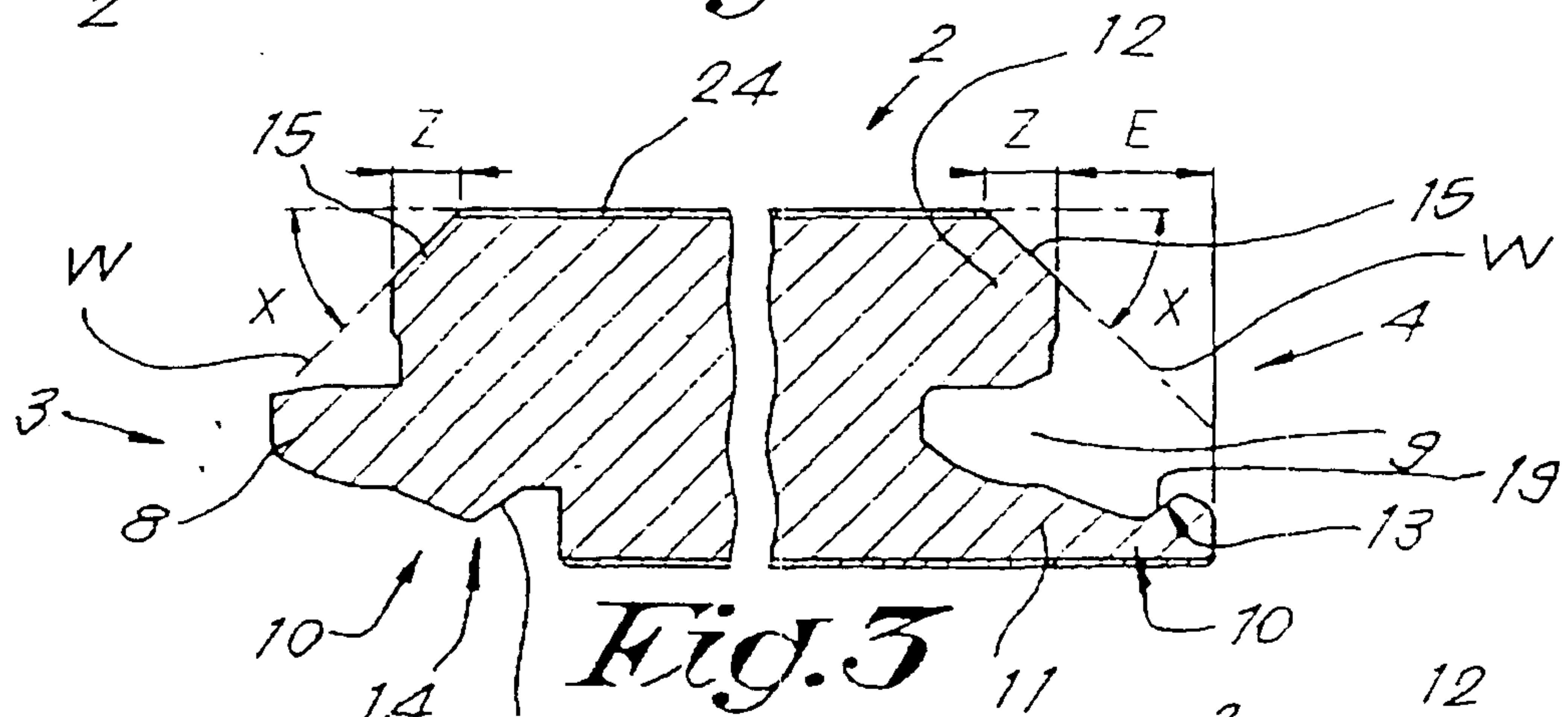

*Fig. 3*

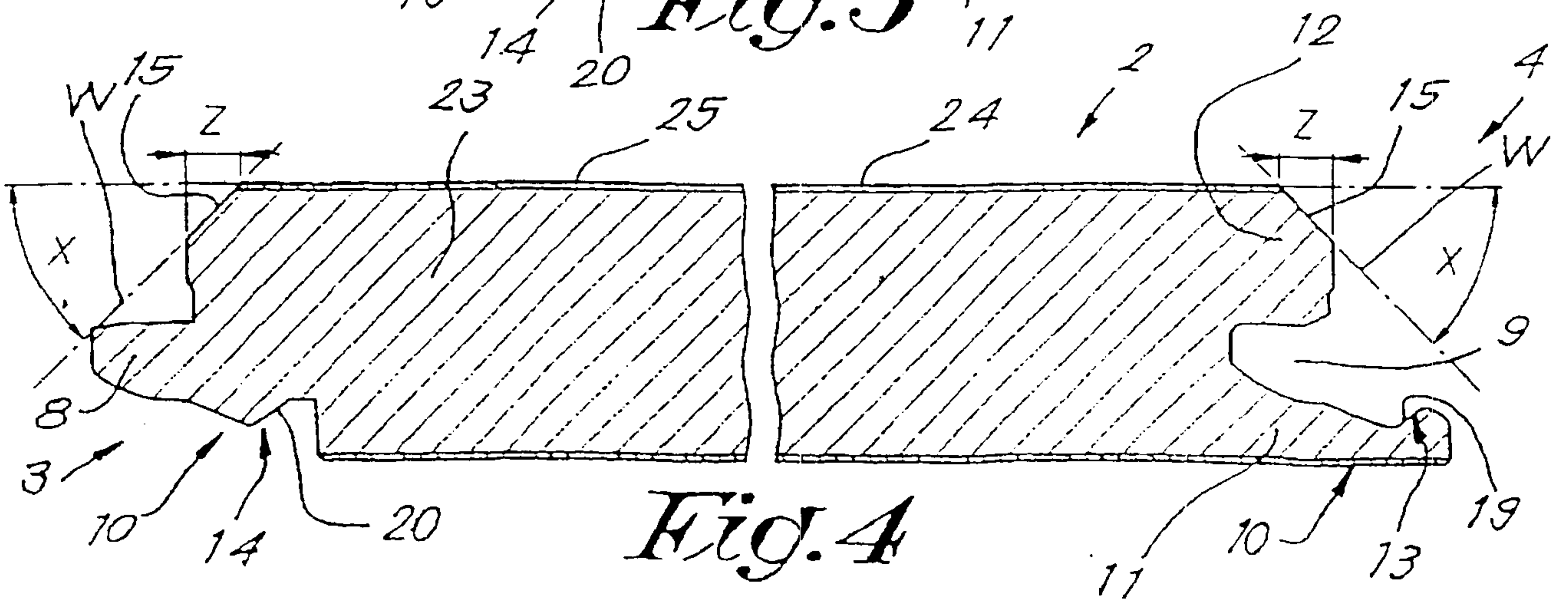

*Fig. 4*

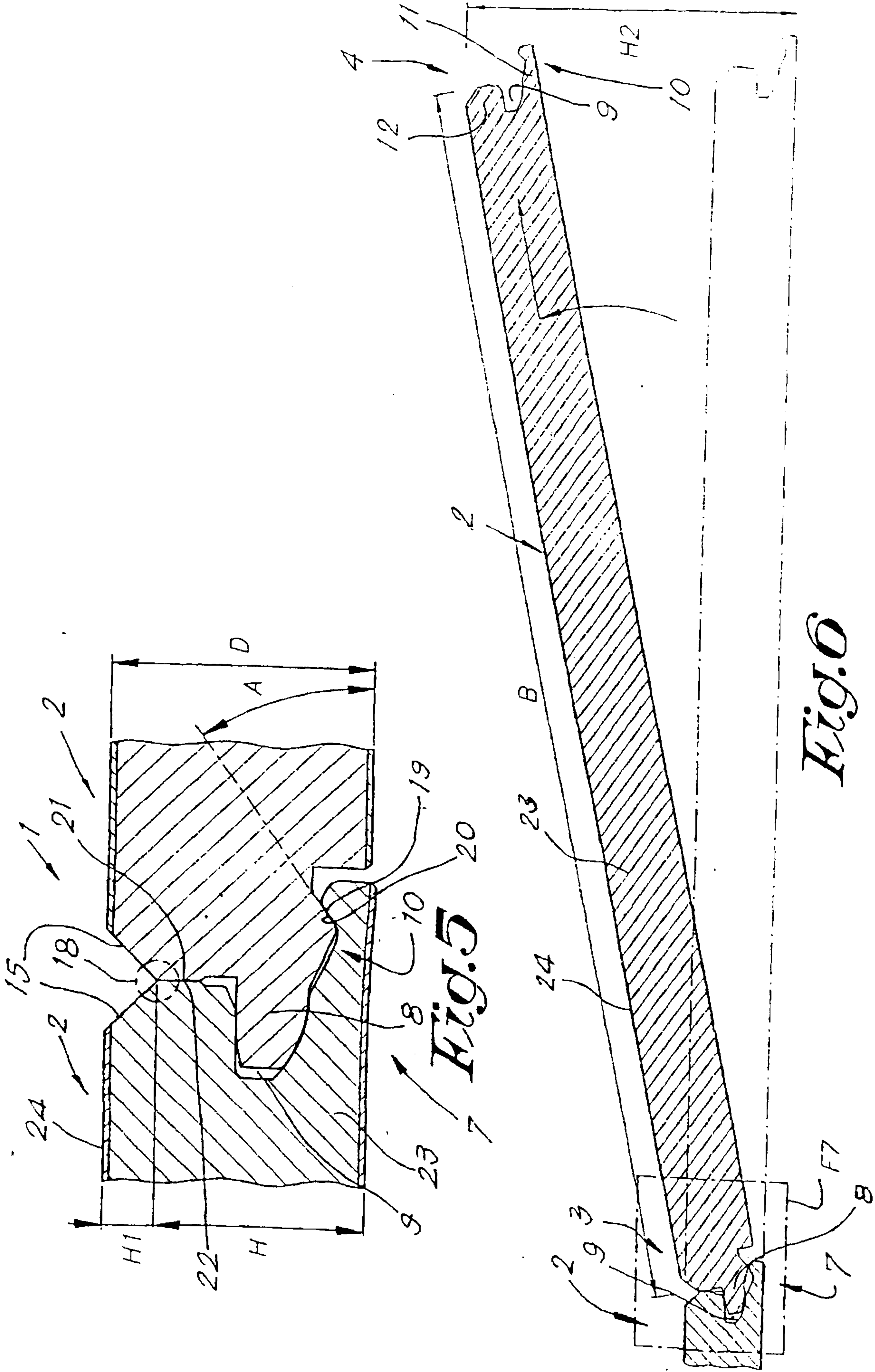
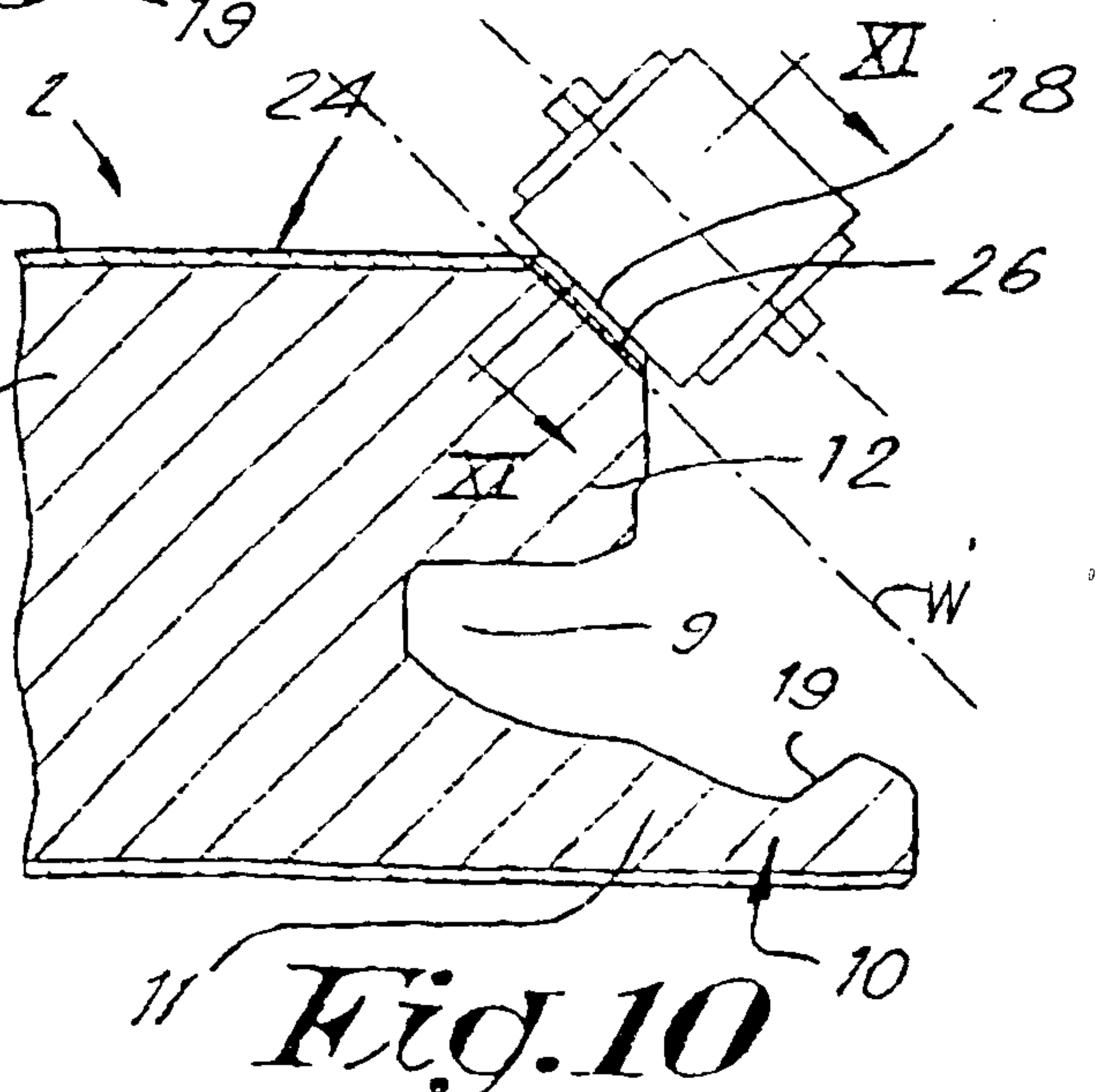
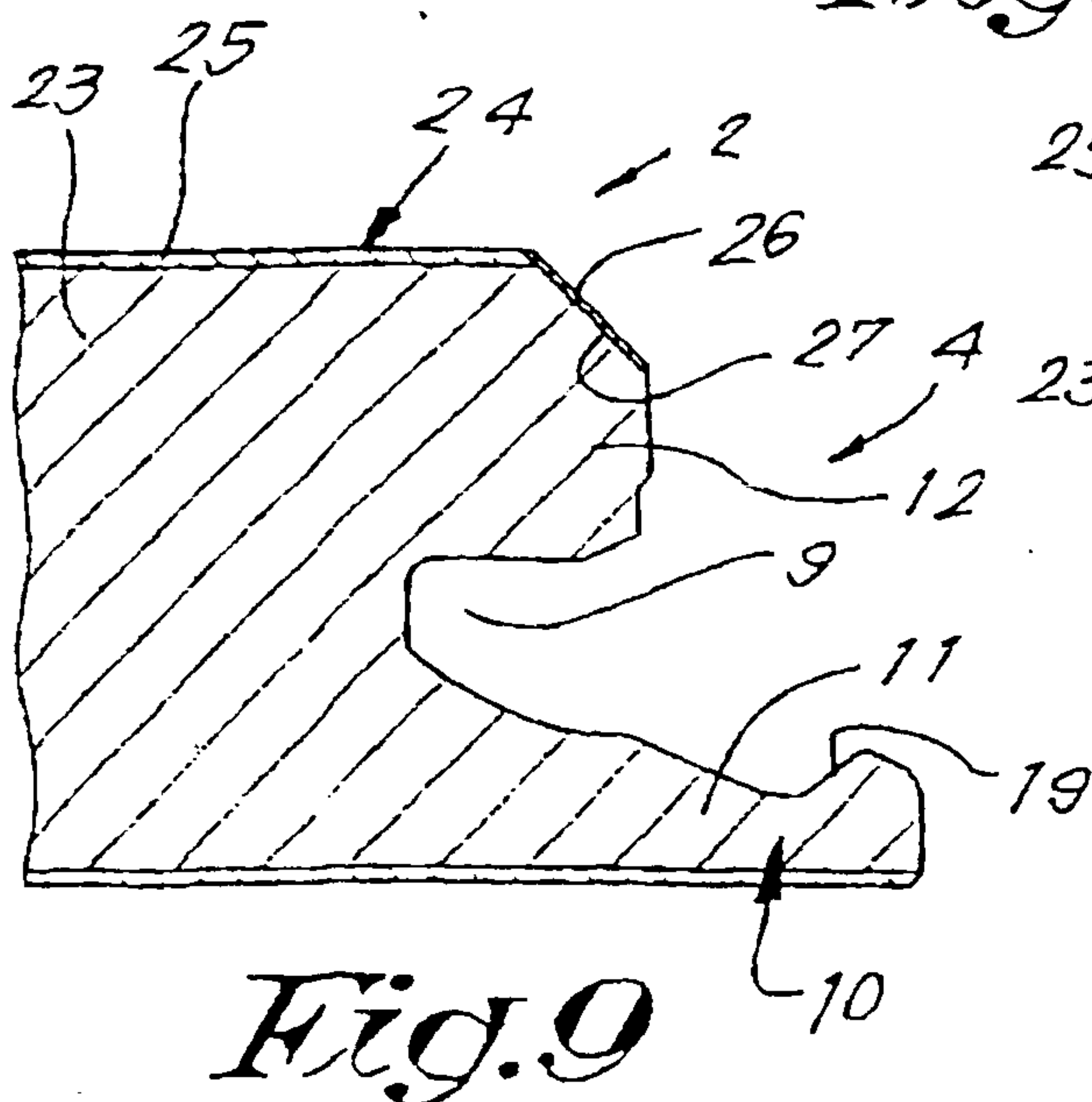
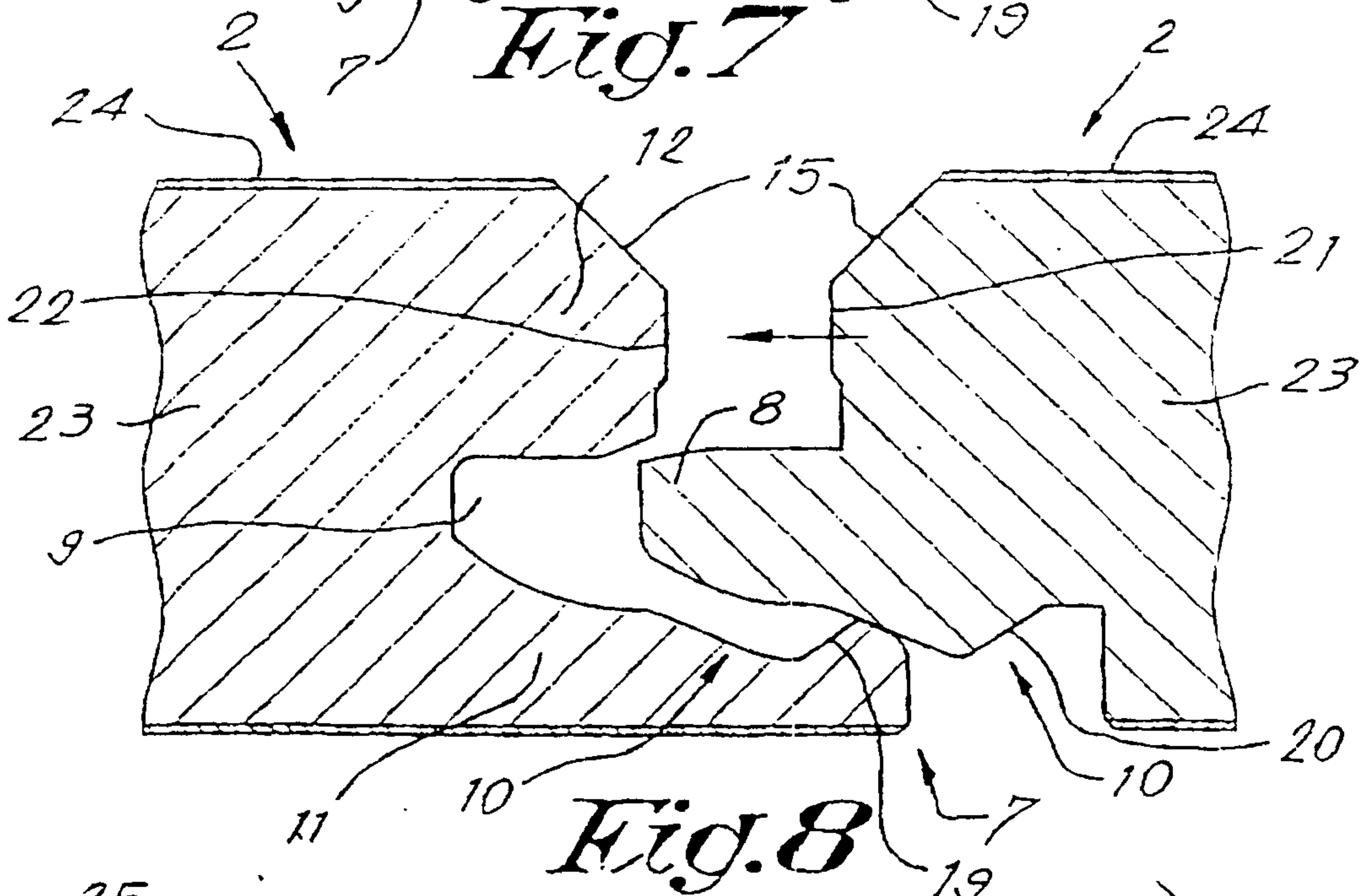
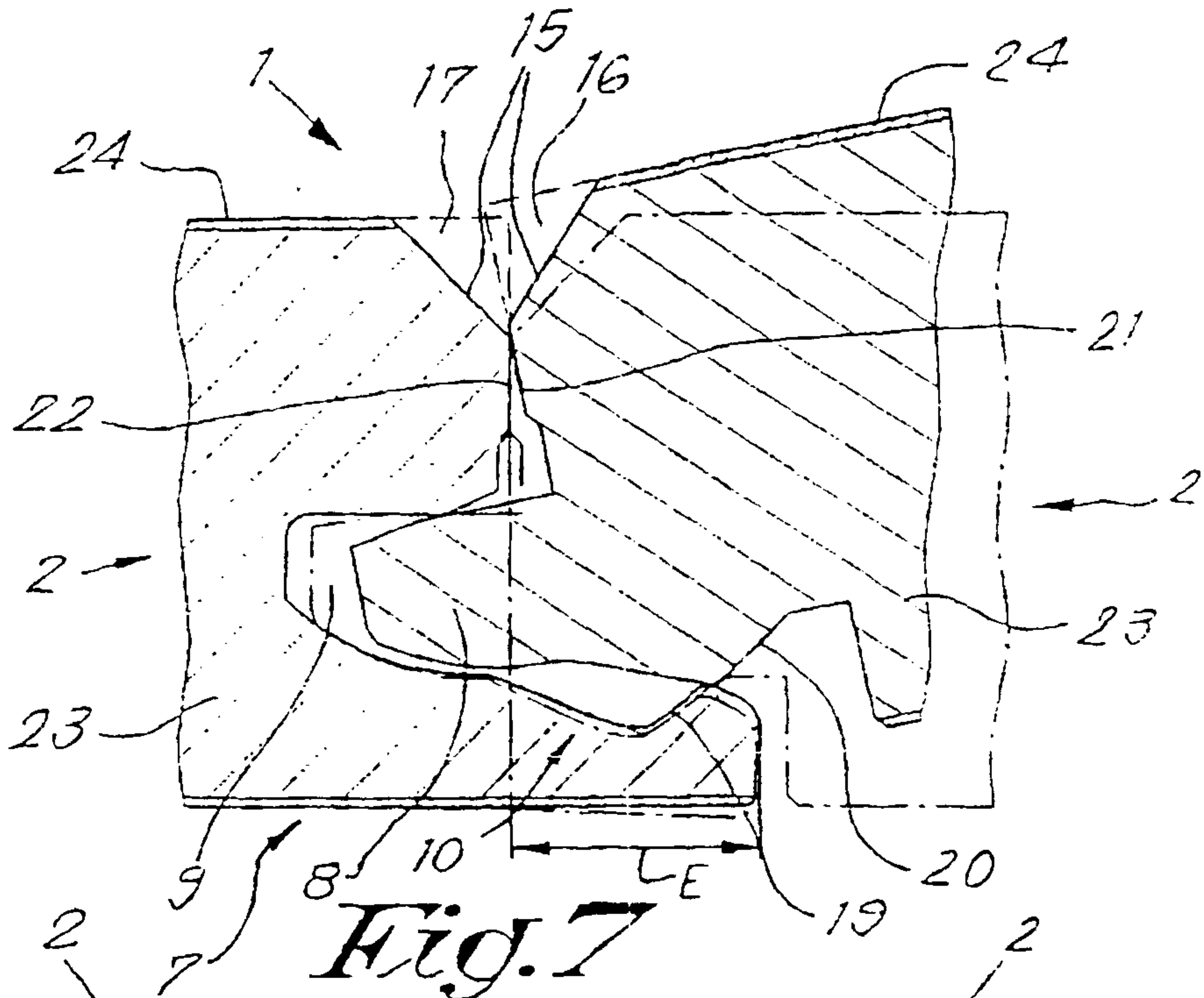
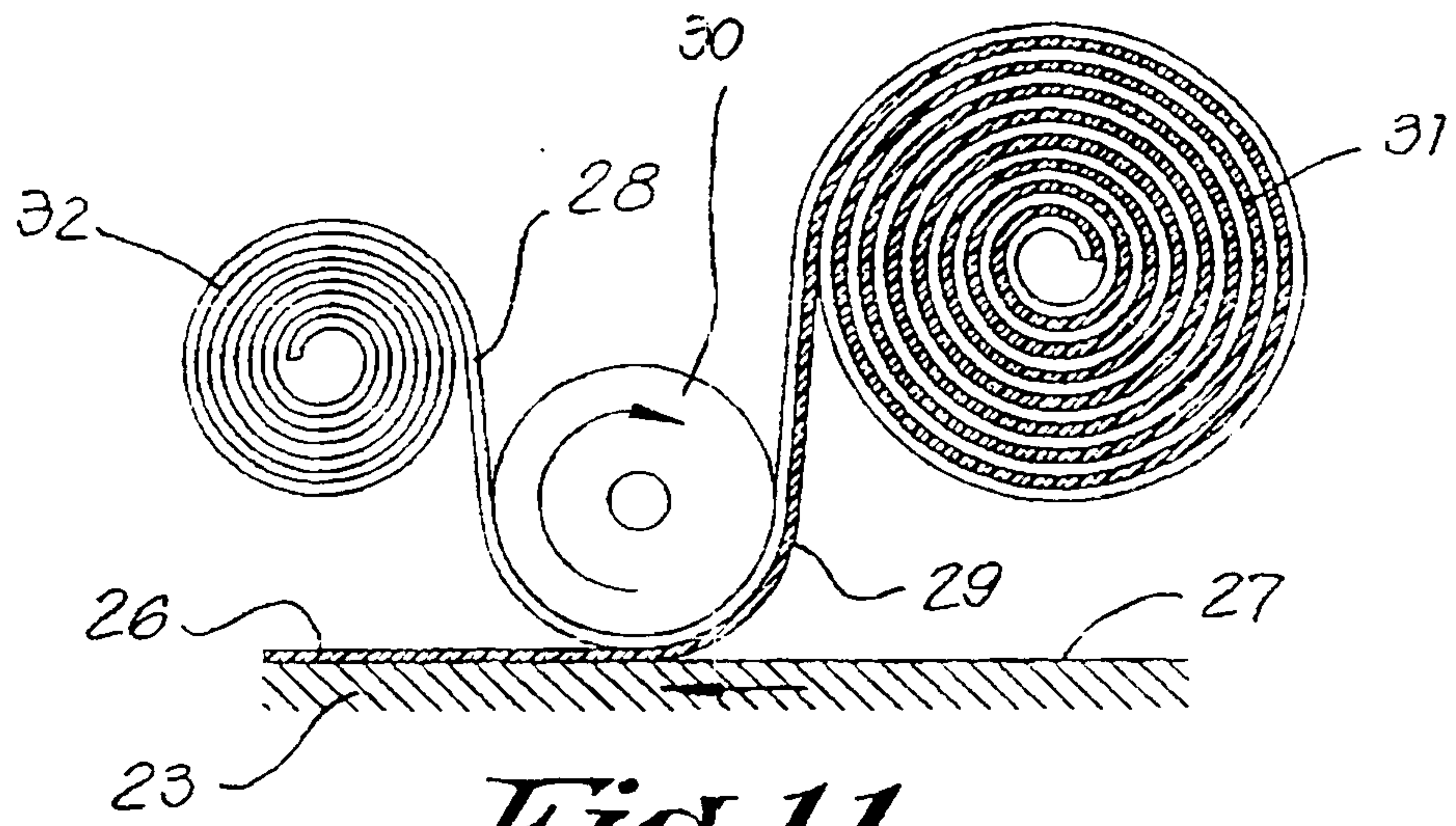

Fig. 6

Fig. 5





*Fig. 11*

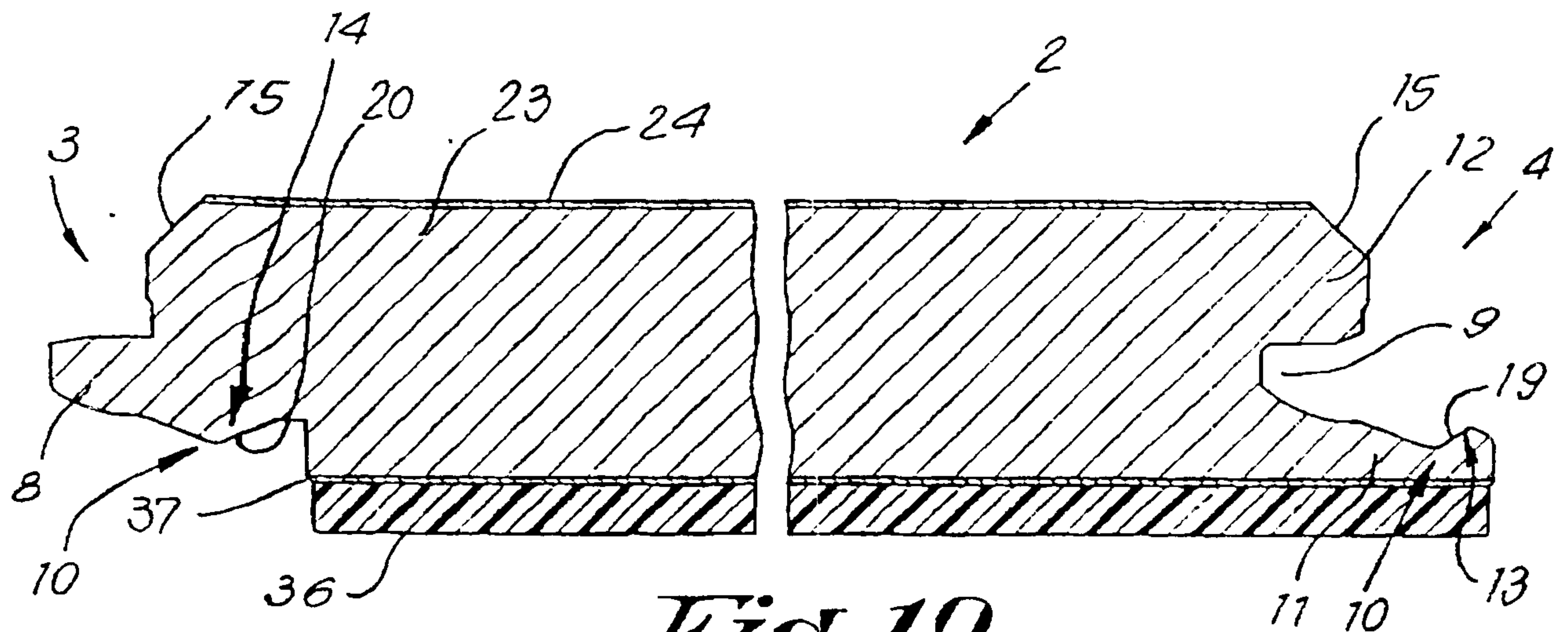

*Fig. 12*

