



(11) **EP 2 067 981 B1**

(12) **EUROPEAN PATENT SPECIFICATION**

(45) Date of publication and mention of the grant of the patent:  
**16.02.2011 Bulletin 2011/07**

(51) Int Cl.:  
**F02M 51/06<sup>(2006.01)</sup>**

(21) Application number: **07023778.9**

(22) Date of filing: **07.12.2007**

(54) **Valve assembly for an injection valve and injection valve**

Ventilanordnung für ein Einspritzventil und Einspritzventil

Ensemble de vanne pour soupape d'injection, et soupape d'injection

(84) Designated Contracting States:  
**DE FR IT**

(72) Inventor: **Grandi, Mauro**  
**57100 Livorno (IT)**

(43) Date of publication of application:  
**10.06.2009 Bulletin 2009/24**

(56) References cited:  
**GB-A- 1 391 330 US-A- 4 151 958**  
**US-A- 5 673 853**

(73) Proprietor: **Continental Automotive GmbH**  
**30165 Hannover (DE)**

**EP 2 067 981 B1**

Note: Within nine months of the publication of the mention of the grant of the European patent in the European Patent Bulletin, any person may give notice to the European Patent Office of opposition to that patent, in accordance with the Implementing Regulations. Notice of opposition shall not be deemed to have been filed until the opposition fee has been paid. (Art. 99(1) European Patent Convention).

## Description

**[0001]** The invention relates to a valve assembly for an injection valve and an injection valve.

**[0002]** Injection valves are in widespread use, in particular for an internal combustion engine where they may be arranged in order to dose the fluid into an intake manifold of the internal combustion engine or directly into the combustion chamber of a cylinder of the internal combustion engine.

**[0003]** Injection valves are manufactured in various forms in order to satisfy the various needs for the various combustion engines. Therefore, for example, their length, their diameter, and all the various elements of the injection valve being responsible for the way the fluid is dosed may vary in a wide range. In addition to that, injection valves can accommodate an actuator for actuating a needle of the injection valve, which may, for example, be an electromagnetic actuator or a piezoelectric actuator.

**[0004]** In order to enhance the combustion process in view of degradation of unwanted emissions, the respective injection valve may be suited to dose fluids under very high pressures. The pressures may be in case of a gasoline engine, for example, in the range of up to 200 bar.

**[0005]** US 4,151,958 discloses a fuel injection nozzle including in assembly the following essential components: a nozzle body; a needle valve and a control member. Two stages of injection are produced both of which are controlled by the needle valve. The control member serves during the second stage of injection and cooperates with the needle valve to effect this stage of injection. For this purpose the control member fits, in a radially sealed manner, within a blind bore formed in the needle valve and defines a channel through which fuel flows under the control of the needle valve. The channel in turn is connected with injection openings for the injection of fuel during the second stage of injection.

**[0006]** The object of the invention is to create a valve assembly for an injection valve and an injection valve which is simple to be manufactured and which facilitates a reliable and precise function.

**[0007]** This object is achieved by the features of the independent claim. Advantageous embodiments of the invention are given in the sub-claims.

**[0008]** The invention is distinguished by a valve assembly of an injection valve, the valve assembly comprising a fluid tube including a central longitudinal axis, the fluid tube having a capped end, a fluid aperture and a fluid tube cavity with a fluid inlet portion and a fluid outlet portion, and a shut-off element axially movable relative to the fluid tube, the shut-off element comprising a sealing portion preventing a fluid flow through the fluid outlet portion and the fluid aperture in a closing position and releasing the fluid flow through the fluid outlet portion and the fluid aperture in further positions, wherein the shut-off element comprises a cavity and the fluid tube is ar-

ranged at least partially inside the cavity. A coupling element is arranged between the sealing portion and an outer surface of the fluid tube and is sealingly coupling the sealing portion with the fluid tube. This has the advantage, that the shut-off element can be operated in a fluid free environment. Therefore, the influence on the opening and closing behavior of the shut-off element due to fluid properties can be kept small. In particular, the influence of the fluid pressure can be kept small. Furthermore, hydraulic sticking effects between the shut-off element and further parts of the valve assembly can be avoided. Consequently, a good dynamic behavior of the valve assembly can be obtained. Furthermore, the dynamic behavior of the valve assembly due to hydraulic sticking effects can be kept constant during lifetime and a dynamic drift of it can be prevented. Additionally, leakage between the sealing element and the outside of the fluid tube can be avoided. Furthermore, an actuating unit of the injection valve can be protected against the fluid.

**[0009]** In an advantageous embodiment of the invention, the valve assembly comprises a seat body being arranged outside the fluid tube, the sealing portion resting on the seat body in the closing position of the shut-off element. This has the advantage, that the sealing area for the seat body can be arranged outside the fluid tube and the hydraulic sticking effects between the shut-off element and further parts of the valve assembly can be avoided.

**[0010]** In a further advantageous embodiment of the invention, the fluid tube and the seat body form a one-piece element. By this, no further assembling and/or welding operation of the fluid tube and the seat body are necessary. Consequently, an exact alignment of the seat body relative to the fluid tube is possible. Furthermore, a low fluid leakage and a high life-time of the valve assembly is possible.

**[0011]** In a further advantageous embodiment of the invention, the seat body and the sealing portion are formed as corresponding ring elements. This has the advantage that a large circumferential sealing area is possible. Consequently, good sealing properties are possible.

**[0012]** In a further advantageous embodiment of the invention, the coupling element has a bellow consisting of a material comprising a rubber and/or a metal. By this, a simple coupling element with good sealing properties can be obtained which allows a flexible movement of the sealing portion relative to the fuel tube.

**[0013]** Exemplary embodiments of the invention are explained in the following with the aid of schematic drawings. These are as follows:

Figure 1, a first embodiment of an injection valve in a longitudinal section view, and

Figure 2, a second embodiment of the injection valve in a longitudinal section view.

**[0014]** Elements of the same design and function that appear in different illustrations are identified by the same reference characters.

**[0015]** An injection valve 10 may be used as a fuel injection valve for a combustion chamber of an internal combustion engine and comprises a valve assembly 14, an actuator unit 16 and a fluid connector 18. The actuator unit 16 has a housing 12.

**[0016]** The fluid connector 18 is designed to be connected to a high pressure fuel chamber of the internal combustion engine, the fuel is stored for example under the pressure of about 200 bar in the case of a gasoline engine and of about 2000 bar in the case of a diesel engine.

**[0017]** The valve assembly 14 comprises a valve body 20 with a central longitudinal axis L. The fluid connector 18 is mechanically and hydraulically coupled to a fluid tube 22. The fluid tube 22 is fixed to the housing 12 on one of its free end.

**[0018]** The fluid tube 22 has a tube cavity 24 with a fluid inlet portion 26 and a fluid outlet portion 28. The fluid tube 22 has a capped end 25 facing away from the fluid connector 18. Adjacent to the fluid outlet portion 28 of the tube cavity 24 of the fluid tube 22 an aperture 30 is arranged which can act as an injection nozzle. The aperture 30 may be, for example, an injection hole, but it may also be of some other type suitable for dosing fluid.

**[0019]** The fluid inlet portion 26, the fluid outlet portion 28 and the aperture 30 of the fluid tube 22 are parts of a main fluid line which allows a fluid flow from the fluid inlet portion 26 to the aperture 30.

**[0020]** The valve assembly 14 further comprises a shut-off element 32. The shut-off element 32 comprises a sealing portion 34, an armature 36 and a coupling tube 38. Furthermore, the shut-off element 32 has a cavity 33 which is arranged in direction of the central longitudinal axis L. The fluid tube 22 is at least partially arranged inside the cavity 33 of the shut-off element 32. The coupling tube 38 is mechanically coupling the sealing portion 34 with the armature 36. The sealing portion 34, the armature 36 and the coupling tube 38 may be made in one part or may be separate parts. The shut-off element 32 may comprise further parts. The armature 36 is fixedly coupled to the coupling tube 38 at a first end section 38a of the coupling tube 38. The sealing portion 34 is fixedly coupled to the coupling tube 38 at a second end section 38b of the coupling tube 38.

**[0021]** The shut-off element 32 further comprises a coupling element 40 which is arranged between the sealing portion 34 and an outer surface 31 of the fluid tube 22. The coupling element 40 is mechanically coupling the sealing portion 34 with the fluid tube 22. By this, a sealing coupling between the two parts is possible and a fluid leakage between the sealing portion 34 and the outer surface 31 of the fluid tube 22 can be avoided. The coupling element 40 preferably comprises a bellow 42 which preferably consists of a material which comprises a rubber and/or a metal.

**[0022]** The bellow 42 of the coupling element 40 which is fixedly coupled to the outer surface 31 of the fluid tube 22 and to the sealing portion 34 of the shut-off element 32 enables a sealingly coupling of the sealing portion 34 to the fluid tube 22. By this a fluid flow from the aperture 30 to the actuator unit 16 can be avoided.

**[0023]** A spring 44 is arranged in a recess of the housing 12 preferably to rest on a first spring rest 45a of the housing 12 and a second spring rest 45b of the armature 36 of the shut-off element 32. By this, the spring 44 is mechanically coupled to the shut-off element 32.

**[0024]** The actuator unit 16 of the injection valve 10 is preferably an electromagnetic drive comprising a coil 46 which is preferably over-molded. The valve body 20, the armature 36 and the coil 46 are forming an electromagnetic circuit. The armature 36 preferably has a large diameter which enables a proper electromagnetic flow through the armature 36 which contributes to a proper controllability of the position of the sealing portion 34 of the shut-off element 32.

**[0025]** If the coil 46 is energized this results in an electromagnetic force acting on the shut-off element 32. The electromagnetic force acts against the mechanical force obtained from the spring 44. By appropriately energizing the coil 46, the shut-off element 32, in particular the sealing portion 34 may in that way be moved away from its closing position which results in a fluid flow through the aperture 30. After a predetermined time the coil 34 may be de-energized again.

**[0026]** The valve assembly 14 has a seat body 48 which is arranged outside the fluid tube 22. The fluid tube 22 and the seat body 48 can form a one piece element (Figure 2) or can be separate parts (Figure 1). If the fluid tube 22 and the seat body 48 are separate parts the seat body 48 is fixedly coupled to the fluid tube 22, for example by welding. The seat body 48 and the sealing portion 34 are formed as corresponding ring elements. By this a large circumferential sealing area is possible and therefore, a good sealing behavior of the valve assembly 14 is possible.

**[0027]** In the following the function of the injection valve 10 is described in detail:

The fluid may flow from the fluid connector 18 to the fluid inlet portion 26 of the fluid tube 22 to the fluid outlet portion 28. If the shut-off element 22 allows a fluid flow through the fluid outlet portion 28 in an opening position fluid may flow through the aperture 30.

**[0028]** The spring 44 forces the sealing portion 34 of the shut-off element 32 towards the seat body 48. In the case when the coil 46 of the actuator unit 16 is de-energized the spring 44 can force the shut-off element 32 to move in an axial direction in its closing position. It is depending on the force balance between the force on the shut-off element 32 caused by the coil 46 and the force on the shut-off element 32 caused by the spring 44 wheth-

er the shut-off element 32 is in its closing position or not.

**[0029]** In the closing position of the shut-off element 32 the sealing portion 34 of the shut-off element 32 sealingly rests on the seat body 48 and consequently a fluid flow through the fluid outlet portion 28 and the aperture 30 is prevented.

**[0030]** In the case that the coil 46 gets energized a force is effected on the shut-off element 32. The shut-off element 32 is able to move in an axial direction out of the closing position. Outside of the closing position of the shut-off element 32 there is a gap between the sealing portion 34 and the seat body 48 at an axial end of the shut-off element 32 facing away from the fluid connector 18. This enables a fluid flow through the aperture 30.

**[0031]** As the fluid tube 22 is at least partially arranged inside the cavity 33 of the shut-off element 32 the shut-off element 32 can be operated in a fluid-free environment. As the magnetic circuit is formed by the valve body 20, the armature 36 and the coil 46 and as these magnetic components are working under a dry condition without fluid, these components are not influenced by fuel properties. Consequently, sticking forces between the armature 36 and the coil 46 can be eliminated and therefore a drift of the opening and closing behavior of the shut-off element 32 due to fluid properties can be avoided. In particular, the fuel pressure cannot influence the opening and closing time of the shut-off element 32.

## Claims

1. Valve assembly (14) of an injection valve (10), the valve assembly (14) comprising

- a fluid tube (22) including a central longitudinal axis (L), the fluid tube (22) having a capped end (25), a fluid aperture (30) and a fluid tube cavity (24) with a fluid inlet portion (26) and a fluid outlet portion (28), and

- a shut-off element (32) axially movable relative to the fluid tube (22), the shut-off element (32) comprising a sealing portion (34) preventing a fluid flow through the fluid outlet portion (28) and the fluid aperture (30) in a closing position and releasing the fluid flow through the fluid outlet portion (28) and the fluid aperture (30) in further positions, wherein the shut-off element (32) comprises a cavity (33) and the fluid tube (22) is arranged at least partially inside the cavity (33), **characterized in that**

a coupling element (40) is arranged between the sealing portion (34) and an outer surface (31) of the fluid tube (22) and is sealingly coupling the sealing portion (34) with the fluid tube (22).

2. Valve assembly (14) in accordance with claim 1, with the valve assembly (14) comprising a seat body (48) being arranged outside the fluid tube (22), the seal-

ing portion (34) resting on the seat body (48) in the closing position of the shut-off element (32).

3. Valve assembly (14) in accordance with claim 2, with the fluid tube (22) and the seat body (48) forming a one-piece element.

4. Valve assembly (14) in accordance with one of the claims 2 and 3, with the seat body (48) and the sealing portion (34) being formed as corresponding ring elements.

5. Valve assembly (14) in accordance with one of the preceding claims, with the coupling element (40) having a bellow (42) consisting of a material comprising a rubber and/or a metal.

6. Injection valve (10) with a housing (12), a valve assembly (14) and an actuator unit (16) according to one of the preceding claims.

## Patentansprüche

1. Ventileinheit (14) eines Einspritzventils (10) mit

- einem Fluidrohr (22), das eine zentrale Längsachse (L), ein verkapptes Ende (25), eine Fluidöffnung (30) und einen Fluidrohrhohlraum (24) mit einem Fluideinlassabschnitt (26) und einem Fluidauslassabschnitt (28) aufweist, und

- einem Absperrerelement (32), das relativ zum Fluidrohr (22) axial beweglich ist und einen Dichtungsabschnitt (34) aufweist, der einen Fluidstrom durch den Fluidauslassabschnitt (28) und die Fluidöffnung (30) in einer Schließposition verhindert und den Fluidstrom durch den Fluidauslassabschnitt (28) und die Fluidöffnung (30) in weiteren Positionen freigibt, wobei das Absperrerelement (32) einen Hohlraum (33) umfasst und das Fluidrohr (22) mindestens teilweise innerhalb des Hohlraumes (33) angeordnet ist,

**dadurch gekennzeichnet, dass** ein Verbindungselement (40) zwischen dem Dichtungsabschnitt und einer Außenfläche (31) des Fluidrohres (22) angeordnet ist und den Dichtungsabschnitt (34) mit dem Fluidrohr (22) in abgedichteter Weise verbindet.

2. Ventileinheit (14) nach Anspruch 1, die einen Sitzkörper (48) aufweist, der außerhalb des Fluidrohres (22) angeordnet ist, wobei der Dichtungsabschnitt (34) in der Schließposition des Absperrerelementes (32) auf dem Sitzkörper (48) ruht.

3. Ventileinheit (14) nach Anspruch 2, bei der das Fluidrohr (22) und der Sitzkörper (48) ein einstückiges Element bilden.

4. Ventileinheit (14) nach einem der Ansprüche 2 und 3, bei der der Sitzkörper (48) und der Dichtungsabschnitt (34) als entsprechende Ringelemente geformt sind.
5. Ventileinheit (14) nach einem der vorangehenden Ansprüche, bei der das Verbindungselement (40) einen Balg (42) besitzt, der aus einem Material besteht, das einen Gummi und/oder ein Metall aufweist.
6. Einspritzventil (10) mit einem Gehäuse (12), einer Ventileinheit (14) und einer Betätigungseinheit (16) nach einem der vorangehenden Ansprüche.

5

10

15

4. Ensemble de soupape (14) selon l'une quelconque des revendications 2 et 3, avec le corps de siège (48) et la partie d'étanchéité (34) qui sont formés comme des éléments annulaires correspondants.
5. Ensemble de soupape (14) selon l'une quelconque des revendications précédentes, avec l'élément de couplage (40) qui a un soufflet (42) constitué d'un matériau comprenant un caoutchouc et/ou un métal.
6. Soupape d'injection (10) avec un boîtier (12), un ensemble de soupape (14) et une unité d'actionneur (16) selon l'une quelconque des revendications précédentes.

## Revendications

1. Ensemble de soupape (14) d'une soupape d'injection (10), l'ensemble de soupape (14) comprenant :
- un tube de fluide (22) comprenant un axe longitudinal central (L), le tube de fluide (22) ayant une extrémité encapsulée (25), une ouverture de fluide (30) et une cavité de tube de fluide (24) avec une partie d'entrée de fluide (26) et une partie de sortie de fluide (28), et un élément de coupage (32) se déplaçant axialement par rapport au tube de fluide (22), l'élément de coupage (32) comprenant une partie d'étanchéité (34) empêchant un écoulement de fluide à travers la partie de sortie de fluide (28) et l'ouverture de fluide (30) dans une position de fermeture et libérant l'écoulement de fluide à travers la partie de sortie de fluide (28) et l'ouverture de fluide (30) dans des positions supplémentaires, dans lequel l'élément de coupage (32) comprend une cavité (33) et le tube de fluide (22) est agencé au moins partiellement à l'intérieur de la cavité (33), **caractérisé en ce** qui :
- un élément de couplage (40) est agencé entre la partie d'étanchéité (34) et une surface externe (31) du tube de fluide (22) et couple de manière étanche la partie d'étanchéité (34) avec le tube de fluide (22).
2. Ensemble de soupape (14) selon la revendication 1, avec l'ensemble de soupape (14) qui comprend un corps de siège (48) qui est agencé à l'extérieur du tube de fluide (22), la partie d'étanchéité (34) reposant sur le corps de siège (48) dans la position de fermeture de l'élément de coupage (32).
3. Ensemble de soupape (14) selon la revendication 2, avec le tube de fluide (22) et le corps de siège (48) qui forment un élément d'une seule pièce.

20

25

30

35

40

45

50

55

FIG 1

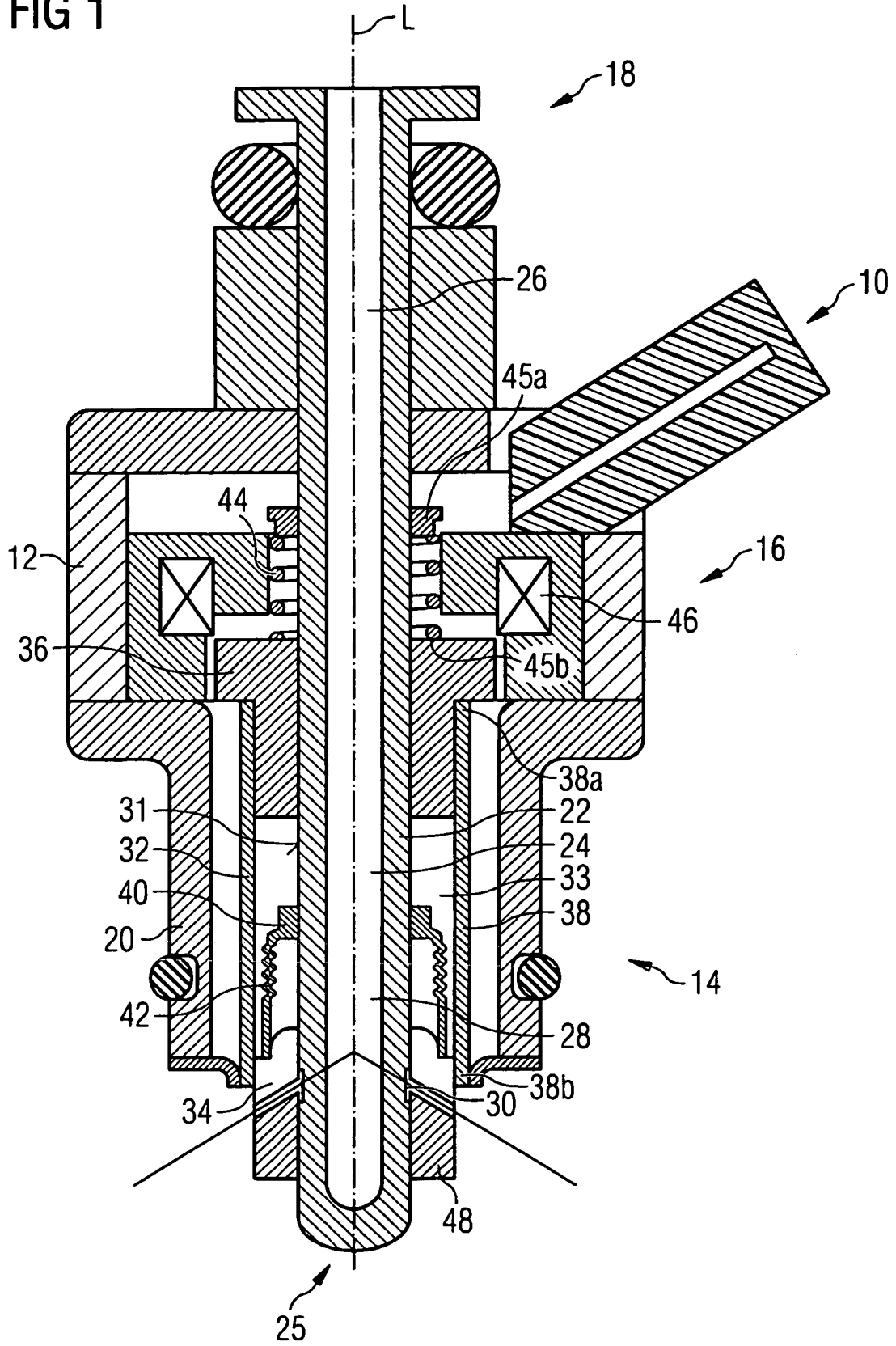



**REFERENCES CITED IN THE DESCRIPTION**

*This list of references cited by the applicant is for the reader's convenience only. It does not form part of the European patent document. Even though great care has been taken in compiling the references, errors or omissions cannot be excluded and the EPO disclaims all liability in this regard.*

**Patent documents cited in the description**

- US 4151958 A [0005]