

Oct. 4, 1949.

P. VAN RIEL

2,483,601

DISCHARGER FOR CENTRIFUGAL MACHINES

Filed Nov. 21, 1945

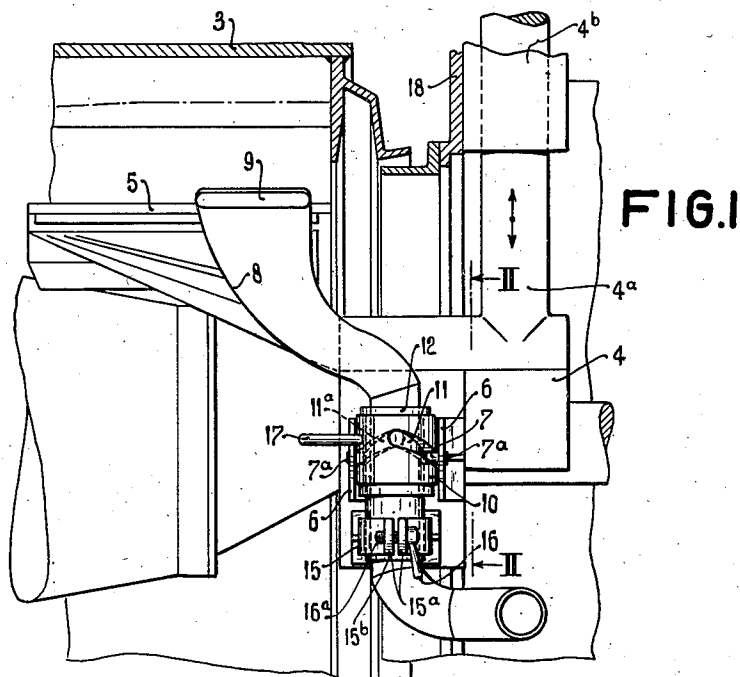

FIG. 1

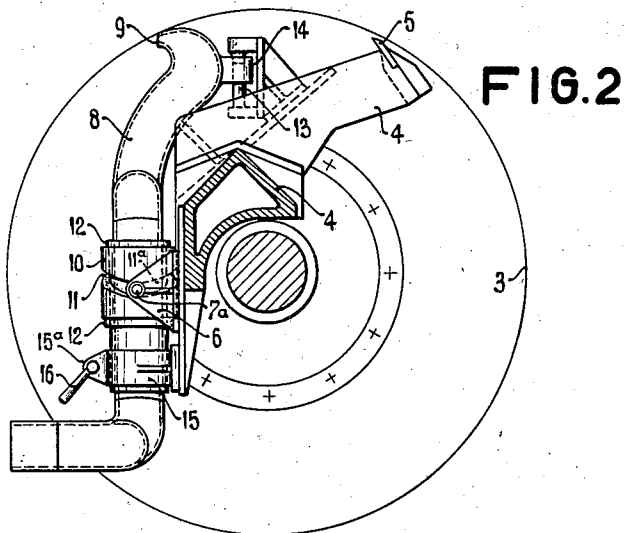

FIG. 2

Inventor
PIETER VAN RIEL
By
Hasetline, Laker & Co.
Attorneys

UNITED STATES PATENT OFFICE

2,483,601

DISCHARGER FOR CENTRIFUGAL
MACHINES

Pieter van Riel, Delft, Netherlands, assignor to
Machinefabriek Reineveld N. V., Delft, Nether-
lands, a company of the Netherlands

Application November 21, 1945, Serial No. 630,079
In the Netherlands November 10, 1942

Section 1, Public Law 690, August 8, 1946
Patent expires November 10, 1962

1 Claim. (Cl. 210—70)

1

This invention relates to a centrifugal machine of the known type comprising a cutting blade or plough for removing the accumulation of solid material from the wall of the basket, and a skimming device for discharging liquid therefrom, said device being adapted to be moved, towards and away from said wall.

The object of the invention is the provision of means whereby, in a centrifugal machine of the above known type, a layer of liquid can be discharged from the basket in a short time. With this object in view, the invention consists herein that the skimming device is adjustably secured to the blade supporting member in such a manner that its mouth can be set selectively at a smaller or at a greater distance from the wall of the basket than the cutting edge of the blade.

The annexed drawing illustrates, by way of example only, part of a horizontal centrifugal basket and of a discharger provided therein according to the invention, Fig. 1 being a longitudinal sectional view, and Fig. 2 a cross sectional view thereof, along the line II—II in Fig. 1.

In the drawing, 3 designates the basket or drum and 4 the blade supporting member, which is adapted to be rectilinearly moved towards and away from the wall of the basket by a vertical rod 4a secured to said member, guided by a sleeve 4b integral with a stationary frame part 18 and adapted for reciprocating movement. Secured to said supporting member are the holder of the blade 5 and two axially spaced brackets 6 providing bearings for rollers 7 rotatably mounted on aligned horizontal trunnions 7a.

The skimming pipe, indicated by 8, has an axially elongated mouth 9. A straight, vertical portion of said pipe is freely encircled by a sleeve 10 provided with two sections of left-handed diametrically opposed helical grooves 11, 11a. By means of two rings 12 clamped on the pipe 8 said sleeve is locked intermediate the two rollers 7 in such a manner that the latter engage the grooves 11. Pipe 8 is prevented from rotation about the axis of sleeve 10 by a vertical pin 13 secured to the blade supporting member 4 and engaging an eye 14 secured to the pipe. Also secured to the blade supporting member 4 is a clamping ring 15 which consists of a split, circular spring ring secured to member 4, the free ends of said ring being bent outward to form substantially parallel lugs 15a, 15b, adapted to be moved towards and away from one an-

2

other by means of a screw 16a provided with a handle 16. This screw is in threaded engagement with lug 15b, its head engaging the other lug 15a, in which the screw 16a is freely rotatable. Thus, obviously, the operator can, by means of handle 16, release or lock pipe 8.

From the above description it follows that sleeve 10, when the same is turned by the operator by means of a handle 17 secured thereto and clamping ring 15 disengages pipe 8, is raised or lowered by the cooperation of rollers 7 with grooves 11, and that pipe 8 is constrained to follow this movement. When said pipe has reached the desired level, it can be locked by means of ring 15.

The arrangement is designed so as to allow the mouth 9 of pipe 8 to be locked in a position at a distance from the wall of the basket selectively appreciably greater or smaller than that of blade 5. If the mouth 9 of the pipe 8 is locked in a position ahead of blade 5, i. e. at a distance from the basket wall smaller than that of the blade, it will be appreciated that manual or mechanical movement of member 4 in upward direction will have the effect that the mouth 9 will skim off the layer of liquid "floating" on the layer of solid material accumulated on the inner wall of the basket, the blade 5 remaining idle. As soon as the liquid layer has thus been removed, the mouth 9 is manually retracted and locked, so that on further outward movement of member 4 the blade 5 will engage the solid layer, while mouth 9 remains out of contact with said layer.

My novel machine may be operated as follows.

During the treatment of a charge, and while the machine is running at full speed, the skimming pipe 8 is set into a position ahead of the blade 5. When the solid material in the charge has accumulated on the wall of the basket, the mechanism for feeding the blade supporting member 4 is cut in, whereby the mouth 9 of pipe 8 will engage the surface of the liquid layer earlier than the blade. Thus, the feeding movement of said supporting member will result in the discharge of the liquid layer. The moment wherein the mouth of pipe 8 has nearly reached the solid layer, the blade 5 is set ahead of the pipe, so that during further outward movement of member 4 the solid layer is scraped from the straining wall and discharged from the gyrating basket.

If the material to be treated is fed into the basket in such a manner as to be first spread

3

over the bottom and thereafter over the wall thereof, then, irrespective of whether the axis of the machine is horizontal or vertical, the thickness of the solid layer accumulated on said wall will decrease, and that of the liquid layer will increase from the bottom towards the edge of the drum. I therefore prefer to mount the skimming pipe remote from the bottom so that it skims off the layer of liquid where the thickness thereof has its maximum value, for under these conditions the greater part of the charge will already be perfectly dry the moment wherein the skimming pipe has nearly reached the solid layer.

What I claim is:

In a centrifugal machine including a basket having a circumferential wall, a cutting blade mounted inside the basket for rotation relatively to the wall, a movable member supporting the blade for adjustable positioning thereof toward and away from the wall, a skimming device mounted for rotation with the blade and in advance thereof comprising a pipe arranged substantially transversely of the basket and having an elongated mouth adjacent the wall, the longitudinal axis of the mouth being substantially parallel to the wall, a slidable connection between the skimming device and the movable

4

member, and locking means, including a clamp integral with the device and surrounding the member, whereby the device may be locked in adjusted position.

PIETER VAN RIEL.

REFERENCES CITED

The following references are of record in the file of this patent:

UNITED STATES PATENTS

Number	Name	Date
893,258	Mills -----	July 14, 1908
1,351,753	Hover -----	Sept. 7, 1920
1,542,747	Verney -----	June 16, 1925
2,083,887	Wieneke -----	June 15, 1937
2,111,508	Jones -----	Mar. 15, 1938
2,119,644	Miller -----	June 7, 1938
2,138,476	Jones -----	Nov. 29, 1938
2,153,581	Miller -----	Apr. 11, 1939
2,243,366	Van Riel -----	May 27, 1941

FOREIGN PATENTS

Number	Country	Date
3,526	Great Britain -----	1913
468,169	Germany -----	Nov. 7, 1928
663,036	France -----	Mar. 29, 1929