

(19) World Intellectual Property
Organization
International Bureau



(43) International Publication Date
25 March 2004 (25.03.2004)

PCT

(10) International Publication Number
WO 2004/025816 A2

- (51) International Patent Classification⁷: **H02M**
- (21) International Application Number:
PCT/US2003/026583
- (22) International Filing Date: 26 August 2003 (26.08.2003)
- (25) Filing Language: English
- (26) Publication Language: English
- (30) Priority Data:
10/241,200 11 September 2002 (11.09.2002) US
- (71) Applicants: **ABB INC.** [US/US]; 501 Merritt 7, Norwalk, CT 06856 (US). **ABB OY** [FI/FI]; Strombergintie 1, FIN-00380 Helsinki (FI).
- (72) Inventors: **GOKHALE, Kalyan, P.**; 4595 South Delphine Drive, New Berlin, WI 53151 (US). **VALLINMAKI, Alpo, K.**; S 52 W 30969 Old Village Road, Mukwonago, WI 53149 (US). **SODO, Nicklas, Jan, Anders**; Palotie 14 A 2, FIN-02760 Espoo (FI).
- (74) Agent: **RICKIN, Michael, M.**; ABB Inc., 29801 Euclid Avenue, Wickliffe, OH 44092-2530 (US).
- (81) Designated States (*national*): AE, AG, AL, AM, AT, AU, AZ, BA, BB, BG, BR, BY, BZ, CA, CH, CN, CO, CR, CU, CZ, DE, DK, DM, DZ, EC, EE, ES, FI, GB, GD, GE, GH, GM, HR, HU, ID, IL, IN, IS, JP, KE, KG, KP, KR, KZ, LC, LK, LR, LS, LT, LU, LV, MA, MD, MG, MK, MN, MW, MX, MZ, NI, NO, NZ, OM, PG, PH, PL, PT, RO, RU, SC, SD, SE, SG, SK, SL, SY, TJ, TM, TN, TR, TT, TZ, UA, UG, UZ, VC, VN, YU, ZA, ZM, ZW.
- (84) Designated States (*regional*): ARIPO patent (GH, GM, KE, LS, MW, MZ, SD, SL, SZ, TZ, UG, ZM, ZW), Eurasian patent (AM, AZ, BY, KG, KZ, MD, RU, TJ, TM), European patent (AT, BE, BG, CH, CY, CZ, DE, DK, EE, ES, FI, FR, GB, GR, HU, IE, IT, LU, MC, NL, PT, RO, SE, SI, SK, TR), OAPI patent (BF, BJ, CF, CG, CI, CM, GA, GN, GQ, GW, ML, MR, NE, SN, TD, TG).
- Published:**
— without international search report and to be republished upon receipt of that report
- For two-letter codes and other abbreviations, refer to the "Guidance Notes on Codes and Abbreviations" appearing at the beginning of each regular issue of the PCT Gazette.*

(54) Title: LOW HARMONIC RECTIFIER CIRCUIT

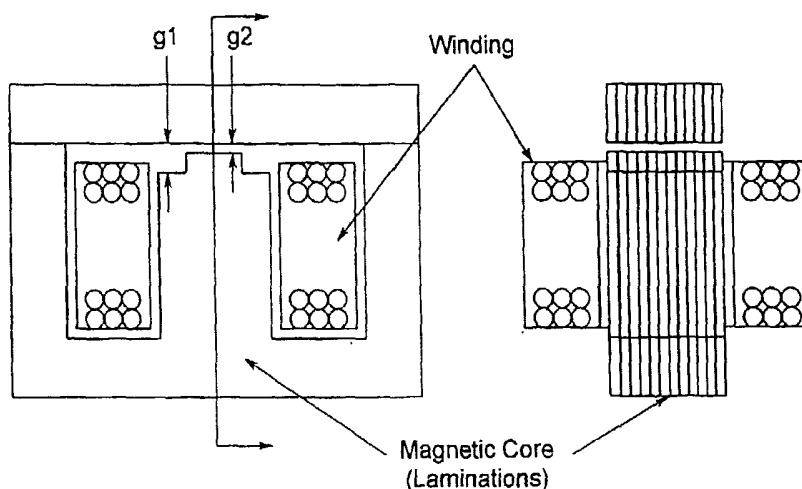

(57) Abstract: Non-linear inductor(s) are used to reduce the percent total harmonic distortion of the harmonics in the line currents in the input side rectifier system of an ac drive system. Several constructions for the non-linear inductor(s) are described. The non-linear inductor(s) may be constructed from E and I laminations. The gap depends on the construction of the middle leg of the E laminations and may have a step with a constant spacing or a variable spacing which depends on the stacking of the laminations. Alternatively the non-linear inductor(s) may be constructed from a toroidal core that either has a step gap or a variable type gap.

WO 2004/025816 A2

Low Harmonic Rectifier Circuit

1. Field of the Invention

This invention relates to the input side rectifier in an ac drive system and more particularly to the inductors used therein.

2. Description of the Prior Art

The two main subsystems of a modern ac drive system are the input side rectifier system and output inverter system. The purpose of the rectifier system is to
10 convert input ac voltage, from the utility source, into an intermediate dc voltage and the purpose of the inverter system is to convert the intermediate dc voltage into a variable frequency and a variable magnitude ac output voltage. The rectifier systems are also used in equipment such as welding, electroplating and uninterruptible power supplies.

The input rectifier system consists of a three-phase diode bridge, either ac or dc side inductor(s) and dc bus capacitors. The three-phase diode bridge converts input
20 ac voltage into dc voltage. The inductor(s) and capacitor(s) serve as a smoothing filter for the intermediate dc voltage. Such a rectifier system, when connected to a sinusoidal voltage utility source, draws non-sinusoidal currents. These harmonic currents are not desirable because of their adverse effects (such as energy losses and malfunction of the sensitive equipment) on the utility network. Therefore, it is of commercial importance to reduce the harmonic currents produced by the rectifier systems.

30 The magnitudes of the harmonic currents are mainly dependent on the value of the ac or dc side inductors and on the average value of the load current on the dc side. Generally speaking, the level of the harmonic line currents commonly measured in percent total harmonic distortion (%THD) is lower if the value of the inductor is large. But the larger the value of the inductor, the

E20020180

2

bigger it is in size and the more expensive it is. Also the %THD increases as the load on the rectifier circuit is reduced from full load to partial load. Since ac drives operate at partial load for most of their operating time, it is important to minimize the %THD of a rectifier circuit at partial load.

The present invention reduces the %THD of the line current of a rectifier circuit by incorporating one or more non-linear inductor(s) in the ac or dc side of the rectifier circuits. Specifically, the invention reduces the %THD of the line current at partial loads when compared with rectifier circuits using conventional (linear) inductors. As an additional benefit, the invention also reduces current ripple stress on the filter capacitor at partial loads.

Summary of the Invention

A system that has a rectifier having an input for connection to an ac source and an output; and an inductance-capacitance filter connected to the output of the rectifier where the inductance comprises one or more non-linear inductors.

A system that has a rectifier having an input for connection to an ac source and an output; one or more non-linear inductors connected between the input of the rectifier and the ac source; and a capacitor connected across the output of the rectifier.

A method for making a non-linear inductor from magnetic material. The method is providing an air gap in the magnetic material that has two or more widths; and adjusting either each of the two or more air gap widths or the width of the magnetic material adjacent to the air gap to produce a desired non-linear inductance characteristic for the inductor.

A method for making a non-linear inductor from laminations of magnetic material having different widths. The method is stacking the laminations to produce an air

E20020180

3

gap with two or more widths; and adjusting the width of the air gap and the number of the laminations to produce a desired non-linear inductance characteristic for the inductor.

A method for making a non-linear inductor from laminations of magnetic material having different widths.

The method is stacking at least a predetermined number of the laminations having one of the different widths and a predetermined number of the laminations having another
10 of the different widths to produce an air gap with two or more widths; and adjusting the arrangement of the predetermined number of the laminations having one of the different widths and the predetermined number of the laminations having the another of the different widths in the stack to produce a desired non-linear inductance characteristic for the inductor.

A non-linear inductor having a first stack of laminations each having the same predetermined shape and at least one leg and at least one step at the end of the
20 at least one leg. The non-linear inductor also has a second stack of laminations each having the same predetermined shape adjacent the first stack of laminations to form a flow path for magnetic flux, the at least one step at the at least one leg end and the second stack of laminations creating an air gap that has two widths between the at least one leg and the second stack of laminations to produce a desired non-linear inductance characteristic for the non-linear inductor.

A non-linear inductor having a first stack of
30 laminations each having the same predetermined shape and at least one leg, a first predetermined number of the laminations in the first stack having a first predetermined length for the one leg and a second predetermined number of the laminations in the first stack having a second predetermined length for the one leg. The non-linear inductor also has a second stack of

E20020180

4

laminations each having the same predetermined shape adjacent the first stack of laminations to form a flow path for magnetic flux, the one leg and second stack of laminations creating an air gap that has at least two widths between the at least one leg and the second stack of laminations to produce a desired non-linear inductance characteristic for the non-linear inductor.

A non-linear inductor that has a magnetic material tape wound toroidal core; and an air gap in the core
10 having at least two widths.

Description of the Drawing

Fig. 1 shows a schematic for a three phase rectifier system that has a dc side filter inductor.

Fig. 2 shows a schematic for a three phase rectifier system that has an ac side filter inductor.

Fig. 3 shows the current through the inductor of the rectifier system of Fig. 1 and Fig. 4 shows the line current through phase A of that system with a linear inductor.

20 Fig. 5 shows the current through the inductor of the rectifier system of Fig. 1 and Fig. 6 shows the line current through phase A of that system with a linear inductor and the load on the system at only a predetermined percentage of the rated load.

Fig. 7 shows inductance versus operating current curves for the linear and non-linear inductors.

Fig. 8 shows the current through the inductor of the rectifier system of Fig. 1 and Fig. 9 shows the line current through phase A of that system with a non-linear
30 inductor.

Fig. 10 shows the current through the inductor of the rectifier system of Fig. 1 and Fig. 11 shows the line current through phase A of that system with a non-linear inductor and the load on the system at only a predetermined percentage of the rated load.

Fig. 12 shows one of the most commonly used

E20020180

5

construction techniques used to make a linear dc side inductor.

Fig. 13 shows a construction technique for making a non-linear inductor using E and I laminations.

Fig. 14 shows another construction technique for making a non-linear inductor using E and I laminations.

Fig. 15 shows a construction technique for making a dc side non-linear inductor in the form of a toroidal core.

10 Fig. 16 shows another construction technique for making a dc side non-linear inductor in the form of a toroidal core.

Description of the Preferred Embodiment(s)

Referring now to Fig. 1, there is shown a three phase rectifier system 10 that has a dc side filter inductor 12 labeled as L. As is shown in Fig. 1, the system has bridge 14 connected directly to the three phases 16a, 16b and 16c of the ac input 16. Bridge 14 has six diodes D1 to D6. Input phase 16a is connected to diodes D1 and D2 at junction 14a, input phase 16b is connected to diodes D3 and D4 at junction 14b, and input phase 16c is connected to diodes D5 and D6 at junction 14c. Filter inductor 12 is connected between the cathode of each of diodes D1, D3 and D5 and one terminal of a capacitor 18, labeled as C, which is in parallel with load 20 represented in Fig. 1 by a resistor labeled Rload. The other terminal of capacitor 18 is connected to the anode of each of diodes D2, D4 and D6.

30 Fig. 2 shows a three phase rectifier system 22 in which bridge 14 is connected to the three phases of ac input 16 through three filter inductors 24a, 24b and 24c. Except for the difference in the location of the filter inductors, systems 10 and 22 are otherwise identical and therefore elements in Fig. 2 which have the same function as a corresponding element in Fig. 1 have the same reference numeral that is used in Fig. 1 for that element.

E20020180

6

While the present invention is described below in connection with the rectifier system of Fig. 1, the description is equally applicable to the rectifier system of Fig. 2.

Referring now to Figs. 3 and 4 there is shown in Fig. 3 the current, I_L , through inductor 12 and in Fig. 4 the line current I_a of input phase 16a for a rectifier circuit that has a linear inductor. The inductance of a linear inductor is substantially constant as a function of the current flowing through it. As an example, the circuit component values are as follows:

$V_{in} = 400V$ rms at 50Hz, line-to-line utility voltage

$L = 1100 \mu H$

$C = 1150 \mu F$

$R_{load} = 14 \Omega$.

Table 1 below shows the harmonic content of the line current I_a in absolute values and as a percentage of the total rms current. The circuit is operating at the rated power level.

20

Table 1

Harmonic Order	Harmonic Current (A)	% of RMS Current
Fundamental	42.66	91.75
5 th	13.86	29.80
7 th	10.49	22.56
11 th	3.84	8.27
13 th	3.68	7.92
17 th	2.49	5.36
19 th	2.34	5.03
RMS Current (A)	46.50 A	
% THD	39.78%	

Referring now to Figs. 5 and 6 there is shown in Fig.

E20020180

7

5 the current I_L through the inductor 12 and in Fig. 6 the line current I_a of phase 16a for a rectifier circuit with a linear inductor but the load on the rectifier circuit is at 33% of the rated load, that is, $R_{load} = 42 \Omega$. Table 2 below shows the harmonic content of the line current I_a in absolute values and as a percentage of the total rms current. The rectifier circuit is operating at a 33% power level.

Table 2

Harmonic Order	Harmonic Current (A)	% of RMS Current
Fundamental	14.69	76.12
5 th	10.01	51.84
7 th	7.10	36.81
11 th	1.73	8.97
13 th	1.35	6.98
17 th	0.86	4.45
19 th	0.74	3.85
RMS Current (A)	19.30 A	
% THD	64.85 %	

10

A comparison of the harmonic data from Table 1 and Table 2 shows that when a linear inductor is used for inductor 12, there is a substantial increase in the percentage of harmonic currents at partial load when compared with the data at rated load.

Replacing the linear inductor by a nonlinear inductor can substantially reduce the harmonic current content of the line current of the rectifier circuit. The nonlinear (also called swinging choke) inductor has a higher value of inductance at lower currents but a lower value of inductance at higher current levels. Fig. 7 shows inductance versus operating current curves for the linear inductor and for the nonlinear inductor where the amount of core material (laminations) and the number of turns of the winding are identical in both inductors. The construction method for the nonlinear inductor is described below.

20

E20020180

8

Figs. 8 and 9 show the inductor current I_L and line current I_a of input phase 16a at rated load, respectively, with a dc side non-linear inductor. Figs. 10 and 11 show the inductor current I_L and line current I_a of input phase 16a at 33% load, respectively, with a dc side non-linear inductor. Tables 3 and 4, below, show the harmonic current data at rated load and at 33% load respectively.

Table 3

Harmonic Order	Harmonic Current (A)	% of RMS Current
Fundamental	42.51	94.16
5 th	11.11	24.60
7 th	8.27	18.31
11 th	4.47	9.90
13 th	2.99	6.62
17 th	2.48	5.48
19 th	2.09	4.64
RMS Current (A)	45.15 A	
% THD	33.67 %	

10

Table 4

Harmonic Order	Harmonic Current (A)	% of RMS Current
Fundamental	14.88	88.86
5 th	5.83	34.81
7 th	4.51	26.94
11 th	1.23	7.36
13 th	1.36	8.14
17 th	0.81	4.81
19 th	0.80	4.78
RMS Current (A)	16.74 A	
% THD	45.87 %	

A comparison of the harmonic data from Table 1 and Table 3 shows that when a non-linear inductor is used, the line harmonics at rated current are lower than the harmonic currents produced by the linear inductor. A comparison of harmonic current data from Table 2 and Table 4 shows that at partial load the non-linear

E20020180

9

inductor produces a substantially lower percentage harmonic currents than the linear inductor.

Referring now to Fig. 12, there is shown the most commonly used construction method to manufacture a linear dc side inductor. This method uses a stack of E and I type magnetic material laminations 30 and 32, respectively, and a winding 34 around the middle leg 30c of the E laminations. A constant width air gap g_1 is introduced at the middle leg 30c of the E laminations. It is also possible to introduce an air gap in the two outer legs 30a, 30b of the E laminations. An approximate equation for the inductance value L of this type of the inductor is:

$$L \propto \mu_0 \frac{N^2}{\left(\frac{g_1}{1} + \frac{g_m}{\mu_r} \right)}$$

where :

g_1 = air gap

g_m = magnetic path length in the laminations

μ_0 = permeability of air

μ_r = relative permeability of lamination material

N = number of turns in the winding.

Eq. 1

Since the relative permeability of the lamination material, μ_r , is quite high (greater than 1000) as compared with the relative permeability of the air (equal to 1) in the gap g_1 , the inductance value is inversely proportional to the width of air gap g_1 . In this type of design for a linear dc inductor, the value of the inductance is, as is shown in Fig. 7, fairly constant over the intended operating current range. The flux density in the laminations 30, 32 is below the saturation flux density level and the relative permeability of the lamination material μ_r is fairly high. At higher current levels, the laminations 30, 32 start saturating which means μ_r of the lamination material starts to rapidly decrease. Therefore, as seen from Eq. 1, inductance value

E20020180

10

also starts to decrease as shown in Fig. 7.

Fig. 13 shows one of the two construction methods for the non-linear inductor of the present invention. As with the linear inductor of Fig. 12, the non-linear inductor of Fig. 13 uses a stack of E and I laminations 40 and 42, respectively and a winding 44 around the middle leg 40c of the E lamination 40.

The linear dc side inductor of Fig. 12 has a constant air gap width g_1 . Instead of that constant air gap width the air gap of the non-linear inductor of Fig. 13 has a step width g_2 (where $g_2 < g_1$) for a portion of the middle leg 40c of the E lamination 40. All of the E laminations 40 used in the construction of the non-linear dc side inductor have an identically cut step air gap. The proportion of the width of the middle leg 40c of the E lamination 40 that produces the smaller air gap g_2 with lamination 42 can be varied to achieve the desired non-linearity effect. For example, the inductance versus current curve for the non-linear inductor shown in Fig. 7 was achieved by choosing the width of gap g_2 to be equal to 25% of the width of gap g_1 and the width of the small air gap g_2 was 40% of the width of the middle leg 40c of the E lamination 40.

The non-linear behavior of the dc side inductor shown in Fig. 13 can be explained as follows. At low operating currents, the μ_r of the laminations 40, 42 is high and the inductance is dominated by the small air gap g_2 and therefore the inductance value is high. As the operating current increases, the lamination material below the small air gap starts to saturate and μ_r decreases rapidly with the consequent rapid decrease in inductance that is shown in Fig. 7 for the non-linear inductor.

When such a non-linear inductor is used as the dc side filter inductor 12 in the rectifier circuit 10 of Fig. 1, the higher value of the inductance at low

E20020180

11

operating currents (partial load) produces a lower magnitude of the current ripple through the inductor, as shown in Fig. 10, when compared with the ripple produced by the linear inductor at partial load as shown in Fig. 5. This reduction in the ripple current is responsible for the lower harmonic currents due to the non-linear inductor at partial loads, as shown in Table 4, when compared with the harmonic currents produced by the linear inductor at partial loads shown in Table 2.

10 Fig. 14 shows the second method to construct the non-linear inductor of the present invention. In this construction the middle leg 50c of some of the E laminations 50 have a constant width air gap g_1 with lamination 52 and the middle leg 50c of the remainder of the E laminations 50 have a different value of constant width air gap g_2 (where $g_2 < g_1$) with lamination 52. The ratio of the number of laminations 50 with a middle leg 50c that has a small air gap with lamination 52 to those that have a big air gap with lamination 52 can be chosen
20 to achieve the desired non-linear effect. The inductance versus current curve for the non-linear inductor shown in Fig. 7 was achieved by choosing that ratio to be equal to 2:3.

The small and big air gap laminations can be placed in different positions relative to each other. In the non-linear inductor of Fig. 14 they are shown with those laminations of the middle leg 50c that produces the smaller air gap with laminations 52 in the center of the entire stack. Another option is to reverse the
30 arrangement where the big air gap laminations are in the center of the stack. Some other arrangements are: side-by-side positioning of small and big air gap laminations or dispersing small and big air gap laminations uniformly throughout the stack of E laminations 50.

While the constructions shown in Figs. 13 and 14 for the non-linear inductor of the present invention uses a

E20020180

12

stack of E and I laminations with the air gap in the middle leg of the E lamination it should be appreciated that:

- a) an air gap having the characteristics described above for the embodiments of Figs. 13 and 14 may also be at either of both of end legs 40a and 40b for the embodiment of Fig. 13 and at either or both of end legs 50a and 50b for the embodiment of Fig. 14; and
- 10 b) the non-linear inductor in both figures may also be embodied using for example only E laminations or using U shaped laminations and I laminations or using only U shaped laminations or any other shape or combination of shapes of laminations that allow for one or more gaps that have the characteristics described above for the embodiments of Figs. 13 and 14.

Fig. 15 shows a construction method for a dc side non-linear inductor in the form of a toroidal core 60. In this construction a tape of a magnetic material is wound 20 in a toroidal shape. An air gap 62 is introduced by cutting core 60 in an axial direction. As shown in the Fig. 15, the larger air gap g1 is placed on the outer edge of the toroidal core 60 and smaller air gap g2 is placed in the middle of the toroidal core 60. In this sense, the construction of Fig. 15 is the toroidal equivalent of the stepped gap E-I construction of Fig. 13.

Fig. 16 shows a construction method for a dc side non-linear inductor in the form of a toroidal core 70 30 which as is described below has an air gap that is different in construction than the air gap of toroidal core 60 of Fig. 15. In core 70 a tape of a magnetic material is wound in a toroidal shape. An air gap 72 is introduced by cutting core 70 in a radial direction. But instead of a constant air gap, the tape or "laminations"

E20020180

13

on the outside (diameter) of the toroidal core 70 have a bigger air gap (g1) than the air gap (g2) in the tape or "laminations" which are inside (diameter) the toroidal core 70. In this sense, the construction of Fig. 16 is the toroidal equivalent of the variable gap E-I construction of Fig. 14.

10 It is to be understood that the description of the preferred embodiment(s) is (are) intended to be only illustrative, rather than exhaustive, of the present invention. Those of ordinary skill will be able to make certain additions, deletions, and/or modifications to the embodiment(s) of the disclosed subject matter without departing from the spirit of the invention or its scope, as defined by the appended claims.

E20020180

14

What is claimed is:

1. A system comprising:

a rectifier having an input for connection to an ac source and an output; and

an inductance-capacitance filter connected to said output of said rectifier where said inductance comprises one or more non-linear inductors.

2. The system of claim 1 wherein each of said one or more non-linear inductors has an inductance value at lower operating current that is higher than the inductor inductance value at a higher operating current.

3. A system comprising:

a rectifier having an input for connection to an ac source and an output;

one or more non-linear inductors connected between said input of said rectifier and said ac source; and

a capacitor connected across said output of said rectifier.

4. The system of claim 3 wherein each of said one or more non-linear inductors has an inductance value at lower operating current that is higher than the inductor inductance value at a higher operating current.

5. A method for making a non-linear inductor from magnetic material comprising:

providing an air gap in said magnetic material that has two or more widths; and

adjusting either each of said two or more air gap widths or the width of said magnetic material adjacent to said air gap to produce a desired non-linear inductance characteristic for said inductor.

6. The method of claim 5 wherein said two or more widths in said air gap are provided by one or more steps in said magnetic material.

7. The method of claim 5 wherein said desired non-linear inductance characteristic for said inductor is produced by adjusting only each of said two or more air

E20020180

15

gap widths.

8. The method of claim 5 wherein said desired non-linear inductance characteristic for said inductor is produced by adjusting only the width of said magnetic material adjacent to said air gap.

9. A method for making a non-linear inductor from laminations of magnetic material having different widths comprising:

stacking said laminations to produce an air gap with two or more widths; and

adjusting the width of said air gap and the number of said laminations to produce a desired non-linear inductance characteristic for said inductor.

10. A method for making a non-linear inductor from laminations of magnetic material having different widths comprising:

stacking at least a predetermined number of said laminations having one of said different widths and a predetermined number of said laminations having another of said different widths to produce an air gap with two or more widths; and

adjusting the arrangement of said predetermined number of said laminations having one of said different widths and said predetermined number of said laminations having said another of said different widths in said stack to produce a desired non-linear inductance characteristic for said inductor.

11. A non-linear inductor comprising:

a first stack of laminations each having the same predetermined shape and at least one leg and at least one step at the end of said at least one leg; and

a second stack of laminations each having the same predetermined shape adjacent said first stack of laminations to form a flow path for magnetic flux, said at least one step at said at least one leg end and said second stack of laminations creating an air gap that has

E20020180

16

two widths between said at least one leg and said second stack of laminations to produce a desired non-linear inductance characteristic for said non-linear inductor.

12. The non-linear inductor of claim 11 wherein said first stack of laminations each have an E shape each having a center leg and end legs and said at least one leg having a step is selected from said center leg or at least one of said end legs.

13. A non-linear inductor comprising:

a first stack of laminations each having the same predetermined shape and at least one leg, a first predetermined number of said laminations in said first stack having a first predetermined length for said one leg and a second predetermined number of said laminations in said first stack having a second predetermined length for said one leg; and

a second stack of laminations each having the same predetermined shape adjacent said first stack of laminations to form a flow path for magnetic flux, said one leg and second stack of laminations creating an air gap that has at least two widths between said at least one leg and said second stack of laminations to produce a desired non-linear inductance characteristic for said non-linear inductor.

14. The non-linear inductor of claim 13 wherein said first predetermined number and said second predetermined number of said laminations in said first stack are selected in a ratio to each other to produce a desired inductance characteristic for said non-linear inductor.

15. The non-linear inductor of claim 13 wherein said first predetermined number and said second predetermined number of said laminations in said first are arranged in an order with respect to each other to produce a desired inductance characteristic for said non-linear inductor.

E20020180

17

16. The non-linear inductor of claim 13 wherein said first stack of laminations each have an E shape each having a center leg and end legs and said at least one leg in said first predetermined number of said laminations having a first predetermined length is selected from said center leg or at least one of said end legs and said at least one leg in said second predetermined number of said laminations having a second predetermined length is selected from said center leg or at least one of said end legs.

17. A non-linear inductor comprising:

a magnetic material tape wound toroidal core; and
an air gap in said core having at least two widths.

18. The non-linear inductor of claim 17 wherein said core is cut in an axial direction to produce said air gap, said air gap having a first width adjacent the edges of said toroidal core and a second width between said first widths.

19. The non-linear inductor of claim 18 wherein said first width is greater than said second width.

20. The non-linear inductor of claim 17 wherein said core is cut in a radial direction to produce said air gap, said air gap having a first width adjacent the outer edge of said toroidal core and a second width adjacent the inner edge of said toroidal core.

21. The non-linear inductor of claim 17 wherein said first width is greater than said second width.

E20020180

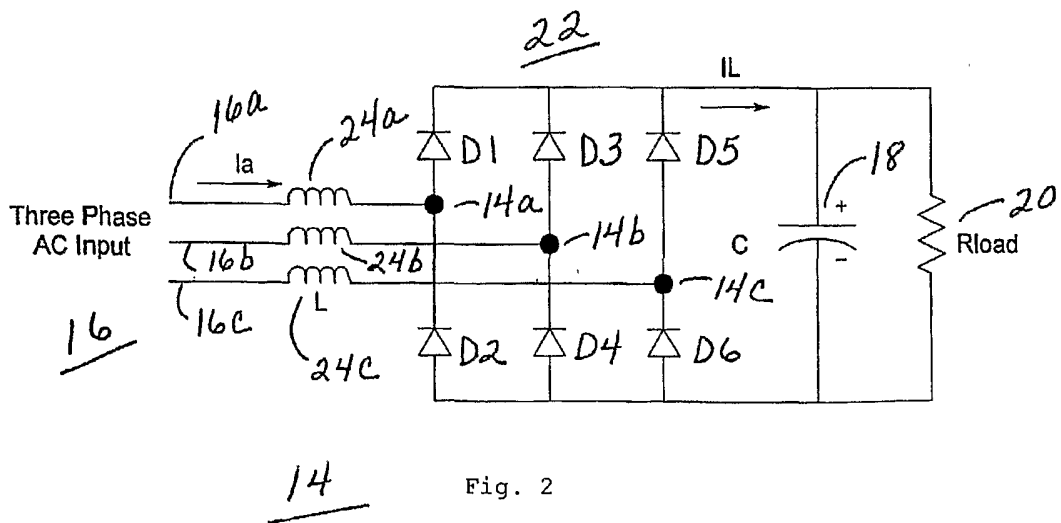
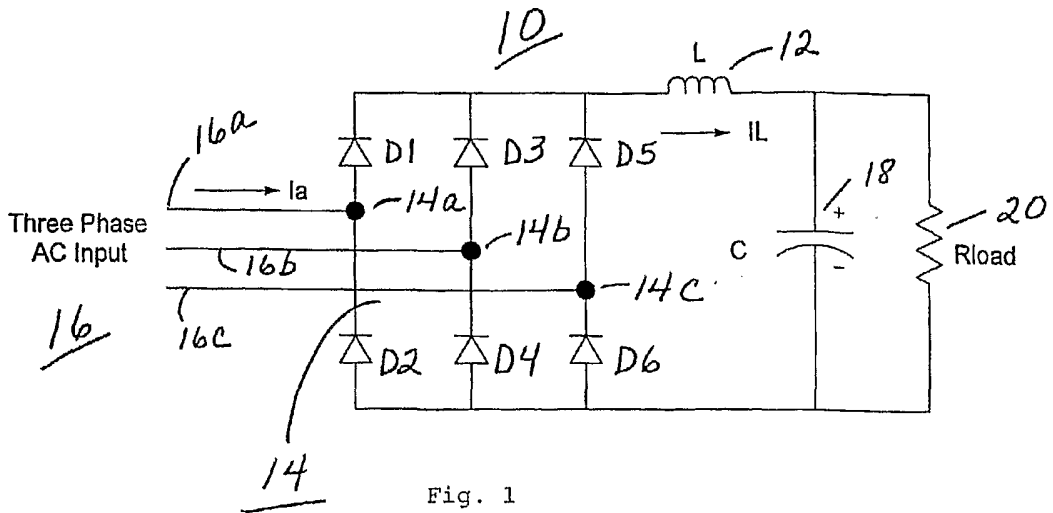

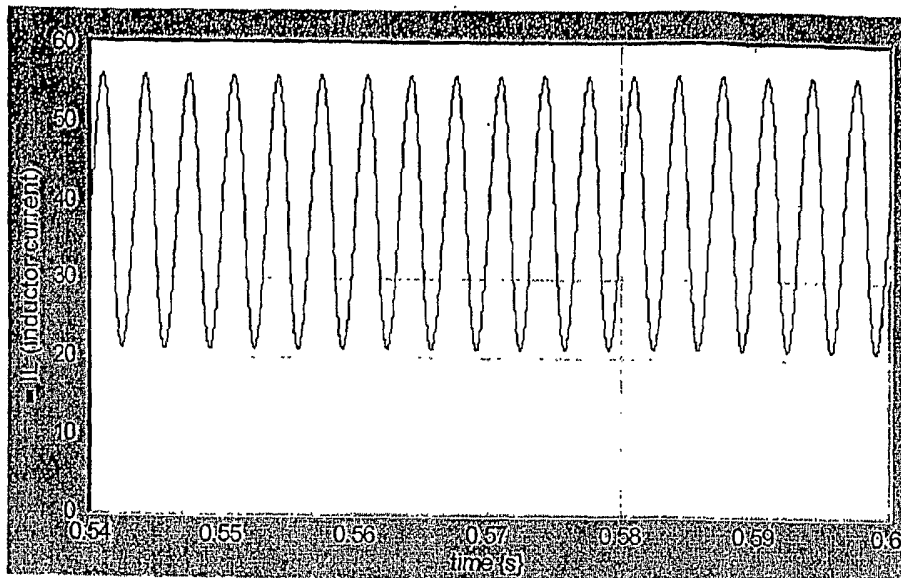

Fig. 3

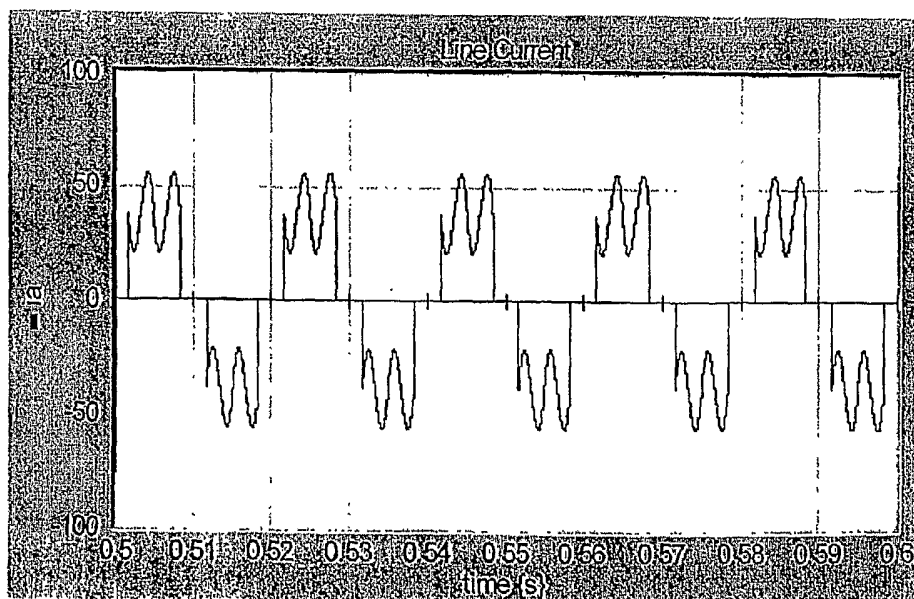

Fig. 4

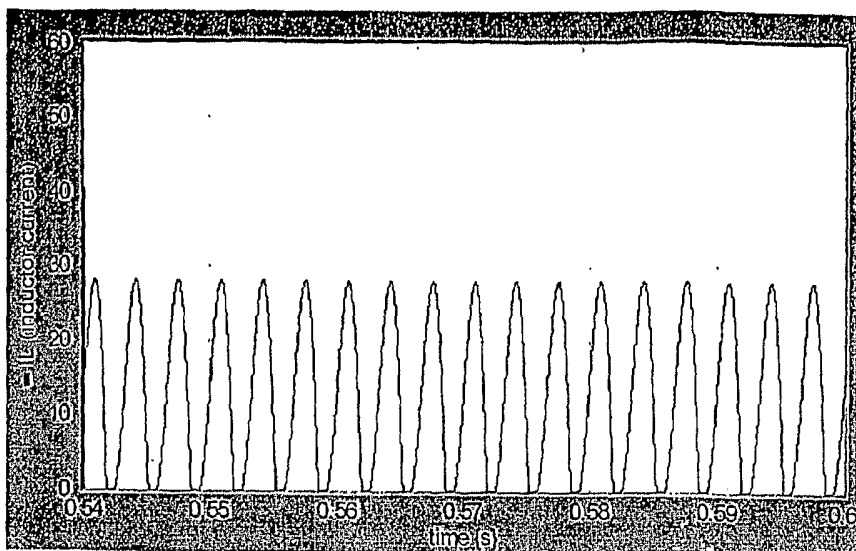

Fig. 5

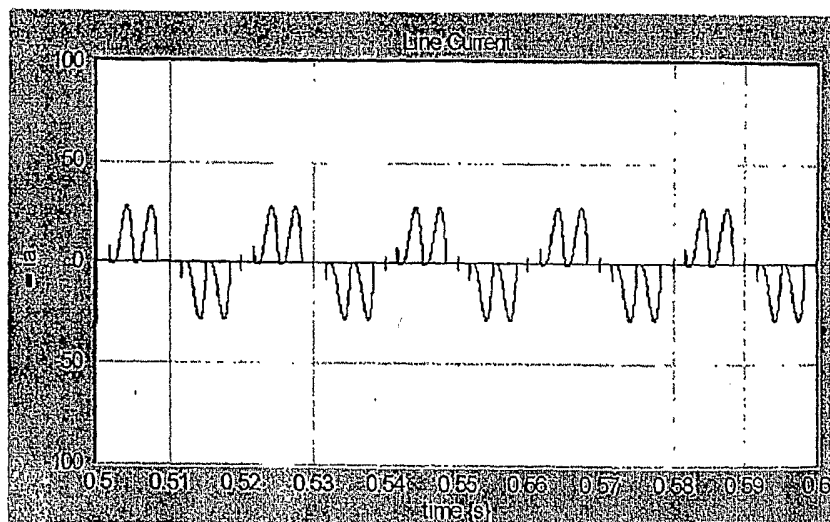

Fig. 6

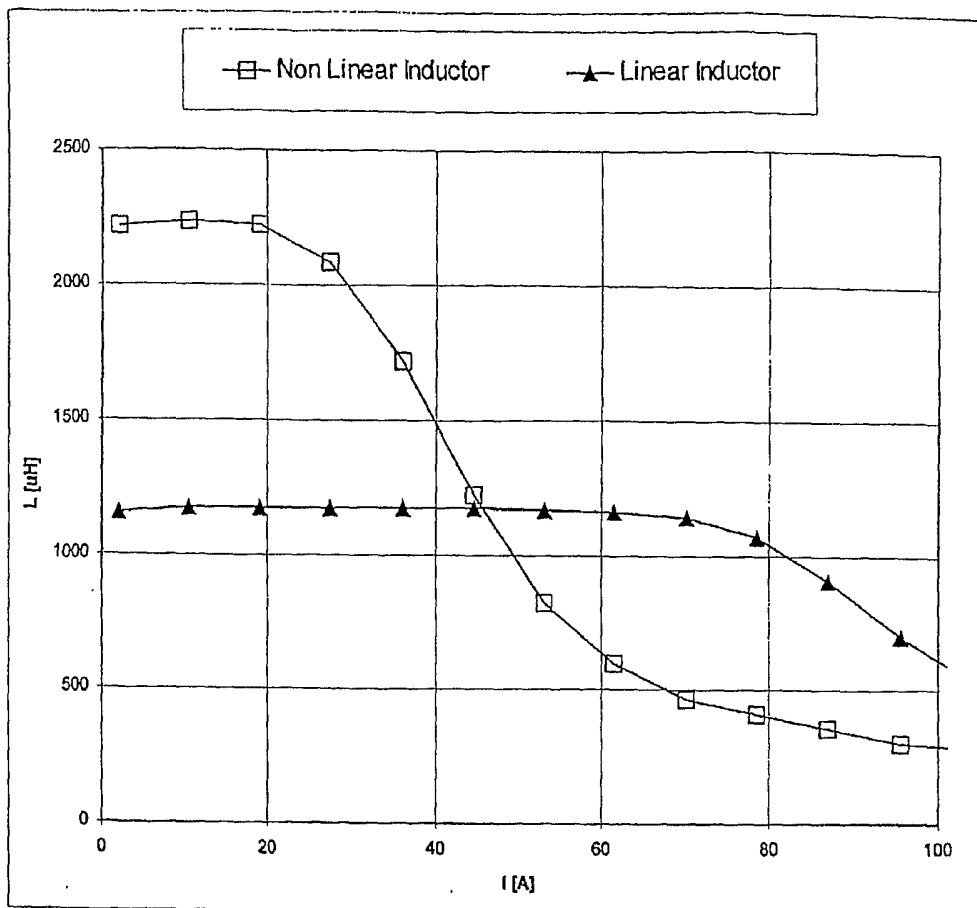

Fig. 7

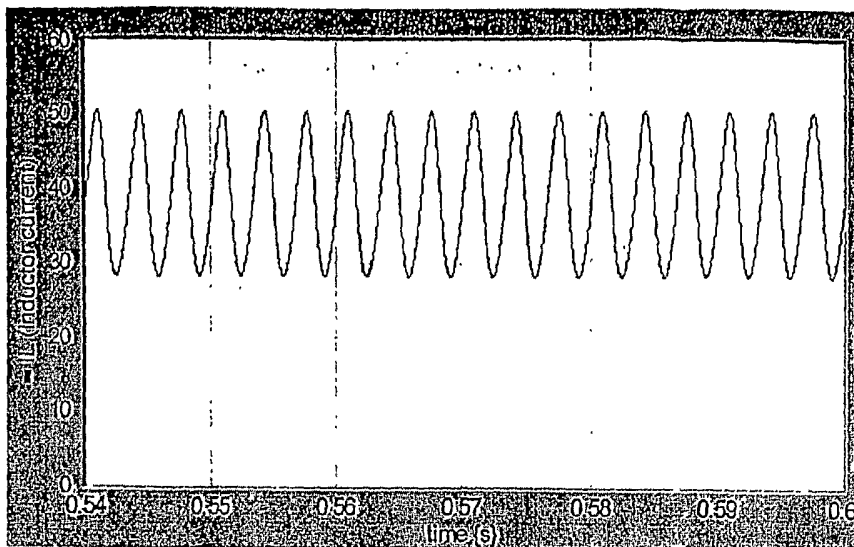

Fig. 8

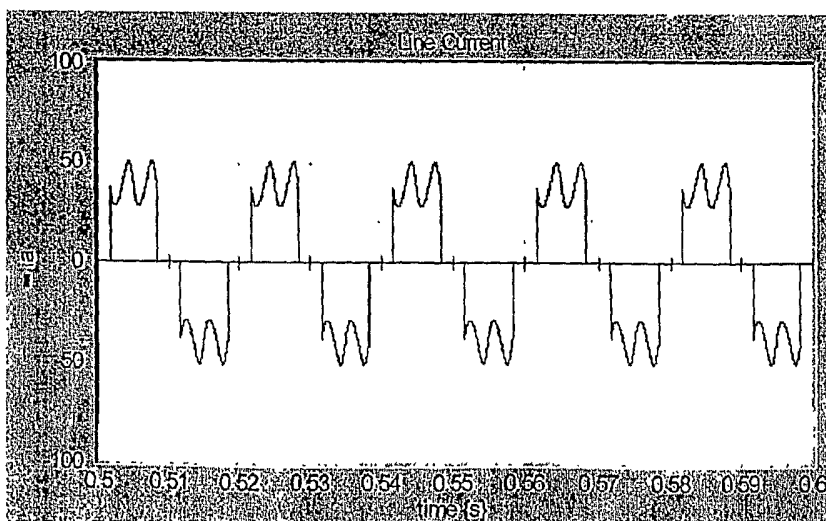

Fig. 9

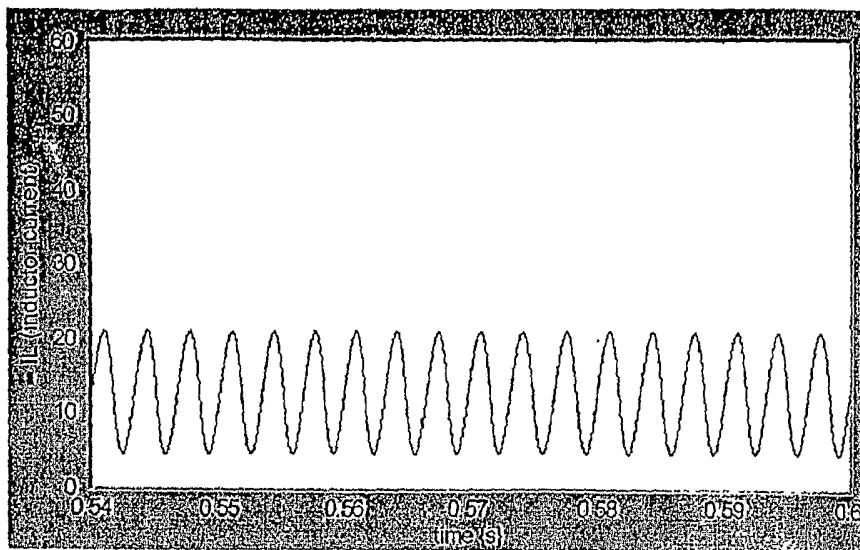

Fig. 10

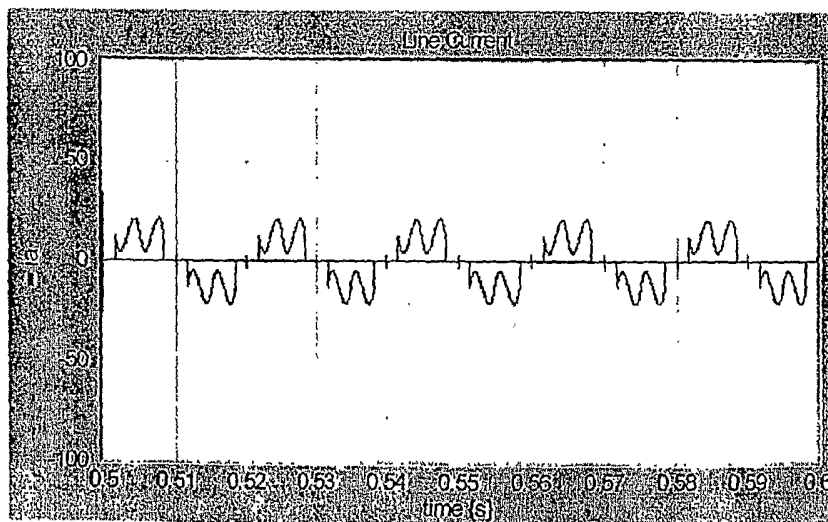

Fig. 11

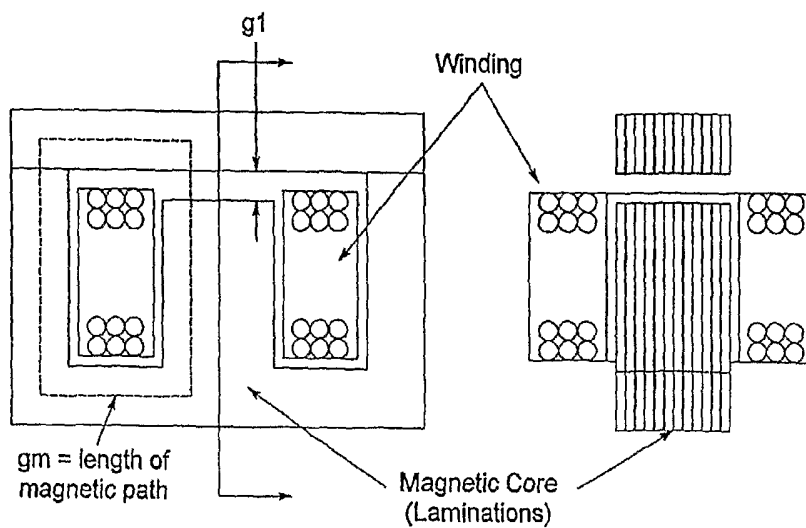

Fig. 12 (Prior Art)

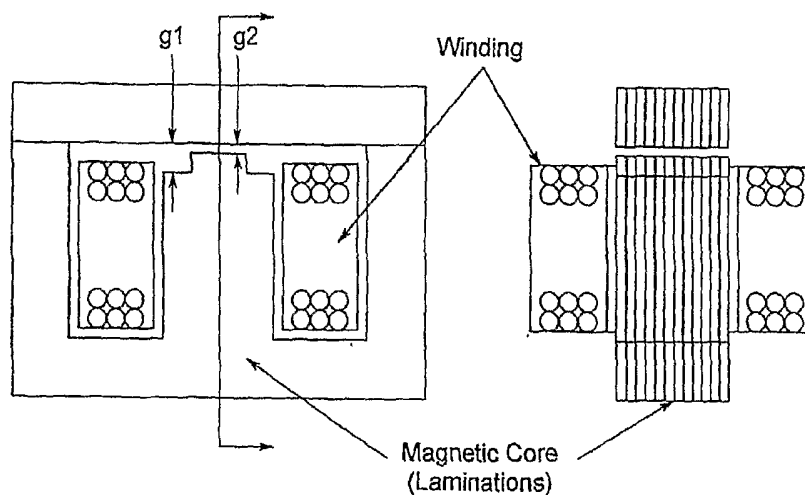

Fig. 13

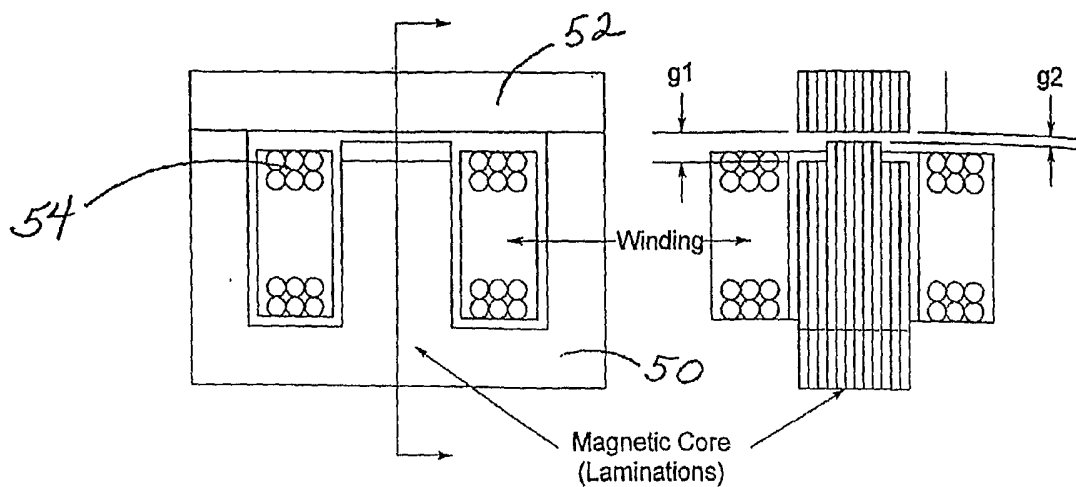

Fig. 14

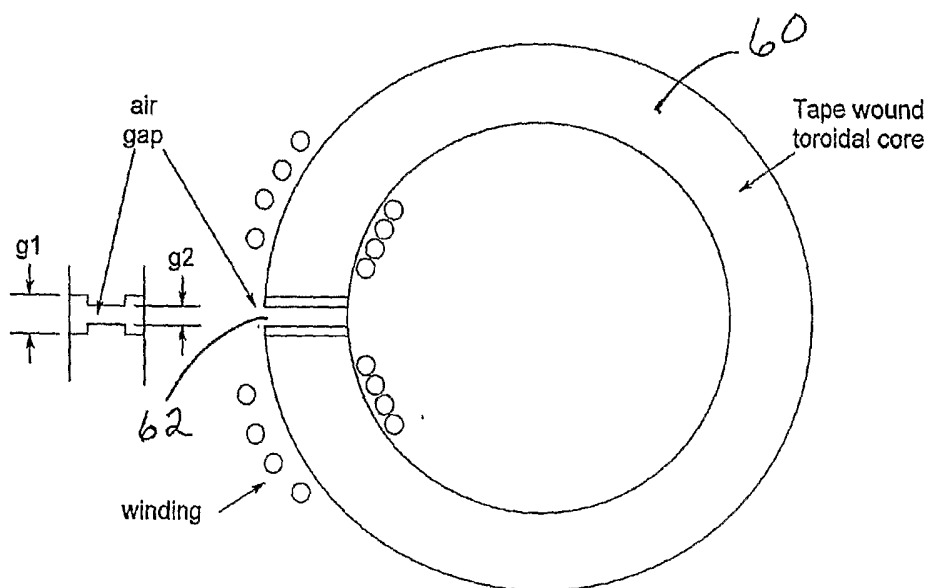

Fig. 15

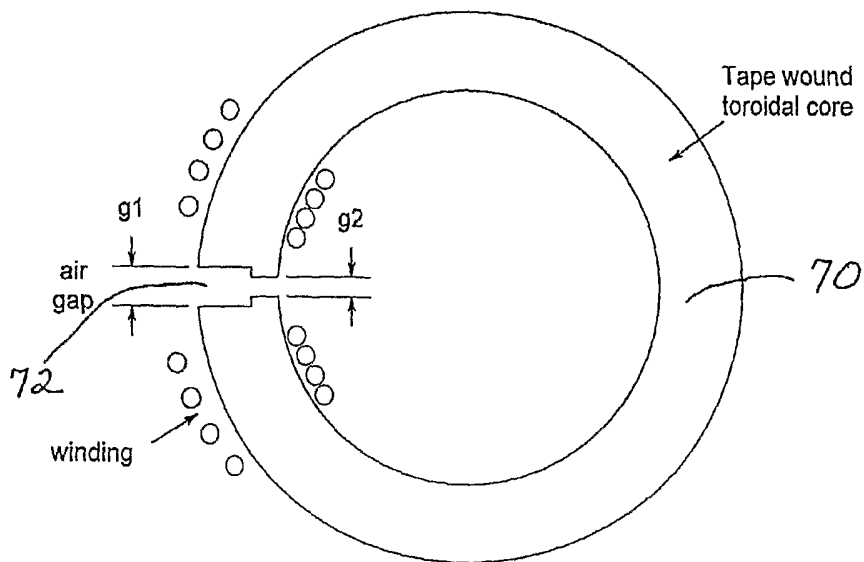

Fig. 16