

No. 641,082.

Patented Jan. 9, 1900.

A. CONKLING.
RECEIVING SHELF FOR MACHINES.

(Application filed Aug. 29, 1899.)

(No Model.)

2 Sheets—Sheet 1.

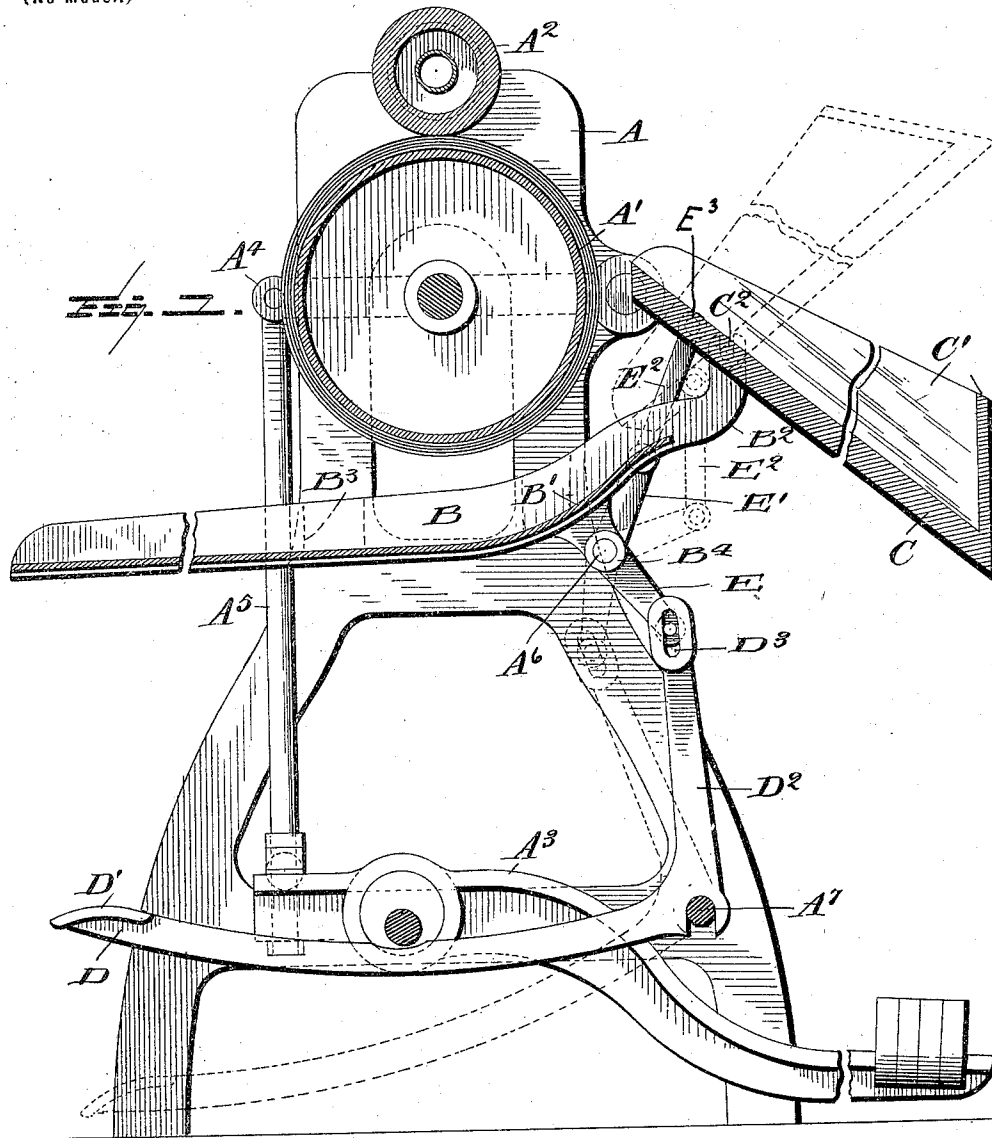

Witnesses:
L. C. Mills.
Alfred T. Luge.

Inventor:
Allen Conkling,
By *E. B. Stocking*
Att'y.

No. 641,082.

Patented Jan. 9, 1900.

A. CONKLING.
RECEIVING SHELF FOR MACHINES.

(Application filed Aug. 29, 1899.)

(No Model.)

2 Sheets—Sheet 2.

Fig. 2.

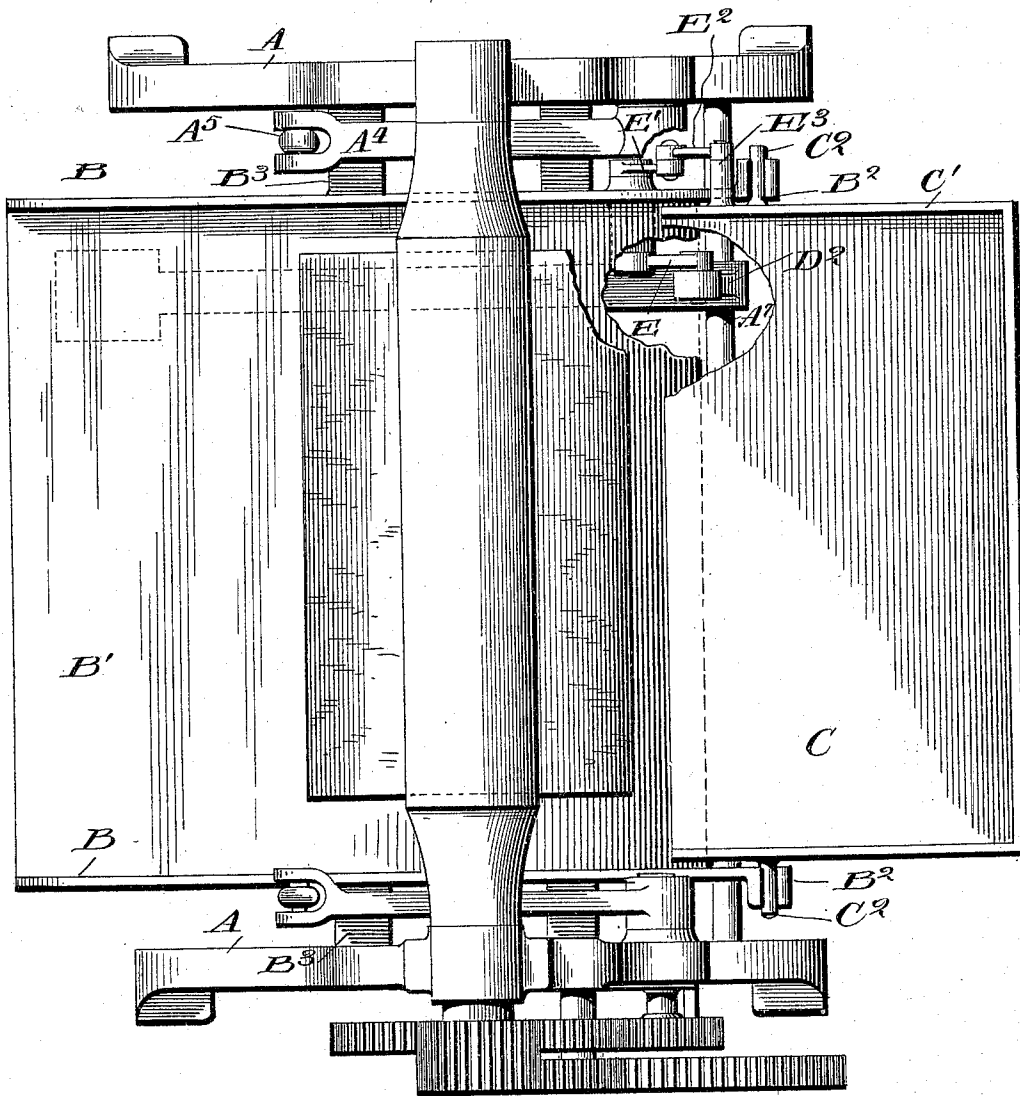

Witnesses:
R. C. Mills,
Alfred T. Sage.

Inventor:
Allen Conkling,
By E. B. Stocking
Atty.

UNITED STATES PATENT OFFICE.

ALLEN CONKLING, OF CHICAGO, ILLINOIS.

RECEIVING-SHELF FOR MACHINES.

SPECIFICATION forming part of Letters Patent No. 641,082, dated January 9, 1900.

Application filed August 29, 1899. Serial No. 728,912. (No model.)

To all whom it may concern:

Be it known that I, ALLEN CONKLING, a citizen of the United States, residing at Chicago, in the county of Cook, State of Illinois, have invented certain new and useful Improvements in Receiving-Shelves for Machines, of which the following is a specification, reference being had therein to the accompanying drawings.

10 This invention relates to a feeding device adapted to operate in connection with the delivery elements of any suitable class of machinery, and particularly with the rolls present in ironing or pressing machines, for the
15 purpose of receiving and retaining the goods upon said device and discharging them therefrom or permitting the goods to be delivered to a receptacle upon a lower plane than said device.
20 The invention has for its object to provide a receiving-shelf having means to retain thereon the goods or articles passing through the operating elements of a machine, said shelf being normally maintained in an inclined position relative to a horizontal plane through
25 the axis of the roll. The object of this particular structure is to prevent the contact of the ends of articles one with another, which is liable to occur when the shelf is maintained
30 in a horizontal position and in a plane substantially that of the delivery-point of the rolls. In such a case the ends of articles such as collars and cuffs upon being delivered from the rolls will strike the end of the preceding
35 article held upon the shelf and rumple or disfigure the same. In this class of machinery it is not practicable to discharge from the table each article as it is received thereon, as there is a continuous delivery of articles from
40 the roll, the same being fed one after another across the longitudinal length of the roll, whereby the article at one end is delivered while an article at the opposite end is being introduced. This permits the operator to iron
45 a large number of articles and maintain a continuous operation of the machine, and as the articles pass from the delivery side of the roll they fall upon the retaining-shelf and lie one upon another, as this shelf is located below the delivery-line of the rolls.

The invention has for an additional object to provide operating means whereby said re-

taining-shelf may be tilted to deliver the goods therefrom to any suitable receptacle communicating with the front of the machine
55 or to permit the goods to fall from the rolls into such a receptacle.

Other objects and advantages of the invention will hereinafter appear in the following description, and the novel features thereof
60 will be particularly pointed out in the appended claims.

In the drawings, Figure 1 represents a vertical cross-section through an ironing-machine with the invention applied thereto, and
65 Fig. 2 is a plan of the same with parts broken away.

Like letters of reference indicate like parts throughout both figures of the drawings.

While it is understood that this feeding device or retaining-shelf may be applied to any
70 desired class of machine, still for the purpose of illustration I have shown in the present instance a form of ironing-machine comprising a framework A, supporting a clothed roll A'
75 and a heated roll A², the former being mounted in movable bearings and held in yielding contact with the heated roll by means of weighted levers A³, pivoted to the frame at each side thereof, bars A⁴, in which the roll A' is pivoted,
80 and connecting-links A⁵ between said levers and bars.

Beneath the roll A' any suitable form of receptacle may be supported, such as a shelf
85 B, having a bottom portion B' inclined toward the front of the machine and provided at the rear with bearing-brackets B², adapted to pivotally support the retaining-shelf C. This receptacle may be supported by any
90 suitable device—for instance, the supporting lugs or brackets B³, extending from the opposite sides of the frame A.

The receiving and retaining shelf C is constructed in any desired manner in order to
95 retain thereon the goods delivered from the rolls, and in the present instance the same is shown as provided with side and end walls C', so arranged as to hold the goods when the shelf stands in its normally-inclined position. (Shown in full lines in Fig. 1.) The shelf is
100 further provided with pintles or pivots C², adapted to rest in the bearing-brackets B², and these pivots C² are located at a point forward of the center of the shelf, so that the

weight of the shelf normally holds the same in the position shown in full lines in Fig. 1 and also automatically returns the shelf to this position after it is released from the tipping mechanism. As showing a desirable form of such tipping mechanism, I have provided a foot-lever D, provided with a step D', which lever is pivotally mounted upon a cross-bar A⁷, carried by the frame A and provided with a rock-arm D², having at its upper end a slot D³. The lower face of the receptacle B is provided with a bearing-lug B⁴, carrying a rock-shaft A⁶. One end of this rock-shaft is provided with a crank-arm E, pivotally connected at the slot D³, while the opposite end of the shaft carries an arm E', pivotally connected to a link E², which link, at its upper end, is pivoted to the retaining-shelf C forward of the bearing-pivot thereof, as shown at E³. It will be seen that a depression of the lever D will tilt or oscillate the retaining-table into the position shown by dotted lines in Fig. 1, and the slotted connection between the oscillating arm D² and the arm E permits a proper movement thereof to exert a greater leverage from the arm D² upon the crank-shaft and connections with the retaining-shelf.

In the operation of the device when the parts are in the position shown by full lines in Fig. 1 the collars or other articles being ironed will fall upon the table in layers one upon another and can be retained thereon until it is desired to return the same to the operator for further ironing or other purposes. When it is desired to thus return the articles, the table is tilted into the position shown by dotted lines, which discharges the articles into the receptacle B, retaining at the same time the polished or finished side of the goods in the same position as when delivered to the shelf. This is important in cases where the opposite side of an article is to be polished by a second ironing operation. When the table or shelf is in the position shown by dotted lines, it will also be obvious that the collars will be delivered directly to the receptacle and not received upon the shelf. For the reasons previously stated it is not desirable to tilt this shelf during the continuous delivery of the goods; but it is usual to wait until a number of articles have been ironed and deposited upon the shelf, when all of the same may be transferred to the receptacle, and thereby to the front of the machine.

If the shelf be tilted during the ironing operation, some of the collars or articles may be damaged, as there is a successive delivery from one end of the roll to the other.

While the mechanism for tilting the shelf has only been illustrated as applied at one side of the machine, it is obvious that the same may be duplicated at the opposite side and may also be supported in any suitable manner to effect the objects of the invention.

It will be further apparent that the device may be applied to any class of machines where found desirable, and changes may be made in the details of construction and configuration of the several parts without departing from the spirit of the invention as defined by the appended claims.

Having described my invention, what I claim as new, and desire to secure by Letters Patent, is—

1. The combination with the operative elements of a machine, of a return-feed device comprising a shelf provided with goods-retaining means and disposed at an angle to a horizontal plane through the operative elements of the machine, and means for tilting said shelf; substantially as specified.
2. The combination with the operative elements of a machine, of a return-feed device comprising a shelf provided with goods-retaining means and mounted below the line of contact of the operative elements of a machine and at an angle to a horizontal plane therethrough, and means for tilting said shelf toward said elements; substantially as specified.
3. The combination with the operative elements of a machine, of a return-feed device comprising a shelf provided with goods-retaining means and mounted below the line of contact of the operative elements of a machine and at an angle to a horizontal plane therethrough, means for tilting said shelf toward said elements, and a receptacle adapted to receive goods from said shelf; substantially as specified.
4. The combination with the operative elements of a machine, of a return-feed device comprising a receptacle supported beneath the operative elements of a machine and provided with bearing-brackets, a tiltable shelf having goods-retaining means and pivoted in said brackets, a rock-shaft and crank-arms, a link pivoted to one of said crank-arms and said shelf, and means for actuating said rock-shaft; substantially as specified.
5. The combination with the operative elements of a machine, of a return-feed device comprising a shelf mounted for oscillatory movement at the delivery side of the operative elements of a machine and provided with means for retaining goods upon said shelf when in an inclined position, pivots and bearings for said shelf located forward of the center thereof, and means for tilting said shelf; substantially as specified.
6. The combination with the operative elements of a machine, of a return-feed device comprising a shelf mounted for oscillatory movement at the delivery side of the operative elements of a machine and provided with means for retaining goods upon said shelf when in an inclined position, pivots and bearings for said shelf located forward of the center thereof, crank-arms pivoted below said shelf, a link connecting one of said arms with

said shelf, and a foot-lever provided with a slotted angle-arm engaging the other crank-arm; substantially as specified.

7. The combination with the operative elements of a machine, of a return-feed device comprising a pivoted shelf provided with goods-retaining means and normally disposed at an angle to and below a horizontal plane through the line of contact of the operative elements of a machine, a receiving-receptacle below the inner end of said shelf, pivots for said shelf at one side of the horizontal center thereof, and means for tilting said shelf located between said pivots and the operative elements of the machine; substantially as specified.

8. The combination with the operative elements of a machine, of a return-feed device comprising a pivoted shelf provided with goods-retaining means and normally disposed at an angle to and below a horizontal plane through the line of contact of the operative elements of a machine, a receiving-receptacle below the inner end of said shelf, pivots for said shelf at one side of the horizontal center thereof, a link pivoted to said shelf between the pivot thereof and said operative elements,

a crank-arm connected to said link, and means for operating said crank-arm; substantially as specified.

9. The combination with a pair of rolls, of a receiving-shelf disposed at an angle to the vertical axis of said rolls below the horizontal line of contact thereof, an end wall for retaining goods upon said shelf when in an inclined position, and means for tilting said shelf toward said rolls; substantially as specified.

10. The combination with a pair of rolls, of a receiving-shelf disposed at an angle to the vertical axis of said rolls below the horizontal line of contact thereof, means for retaining goods upon said shelf, a receptacle beneath said rolls and extending to the opposite side thereof, a pivoted foot-lever mounted upon the frame of said rolls, and connections between said foot-lever and shelf for tilting the latter; substantially as specified.

In testimony whereof I affix my signature in presence of two witnesses.

ALLEN CONKLING.

Witnesses:

R. W. YATES,
J. W. GRIFFEN.