

No. 635,392.

Patented Oct. 24, 1899.

C. H. W. RUHE.
MACHINE FOR BLOWING GLASS.

(Application filed Mar. 9, 1899.)

(No Model.)

3 Sheets—Sheet 1.

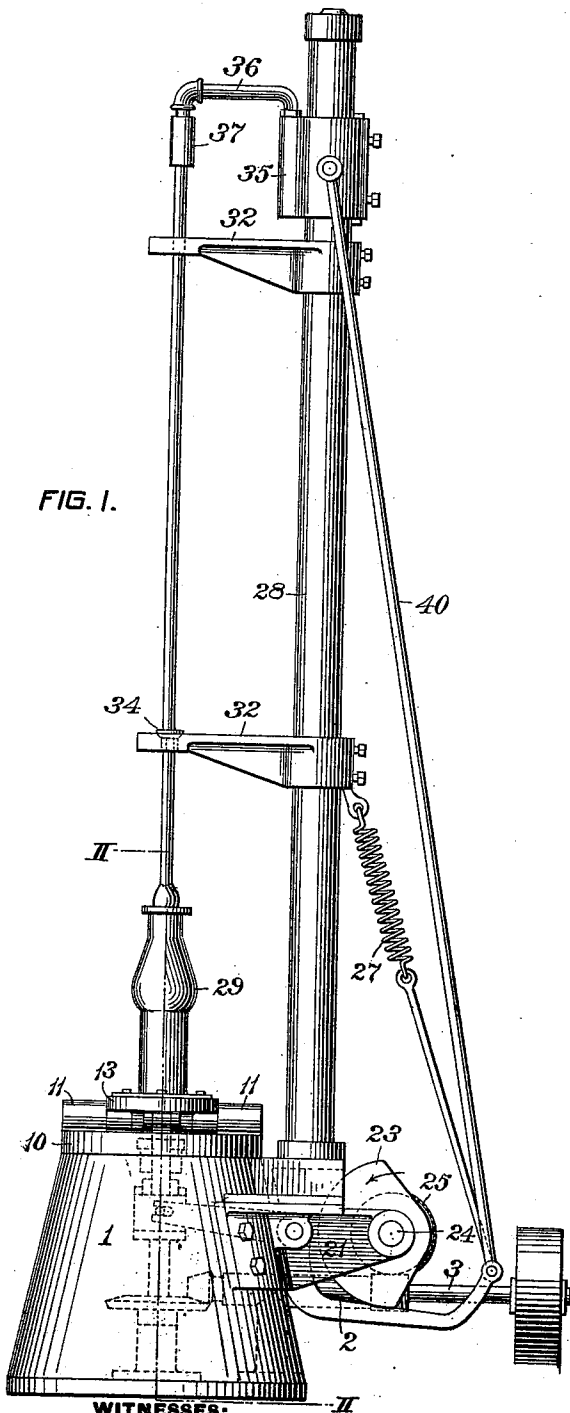

FIG. 1.

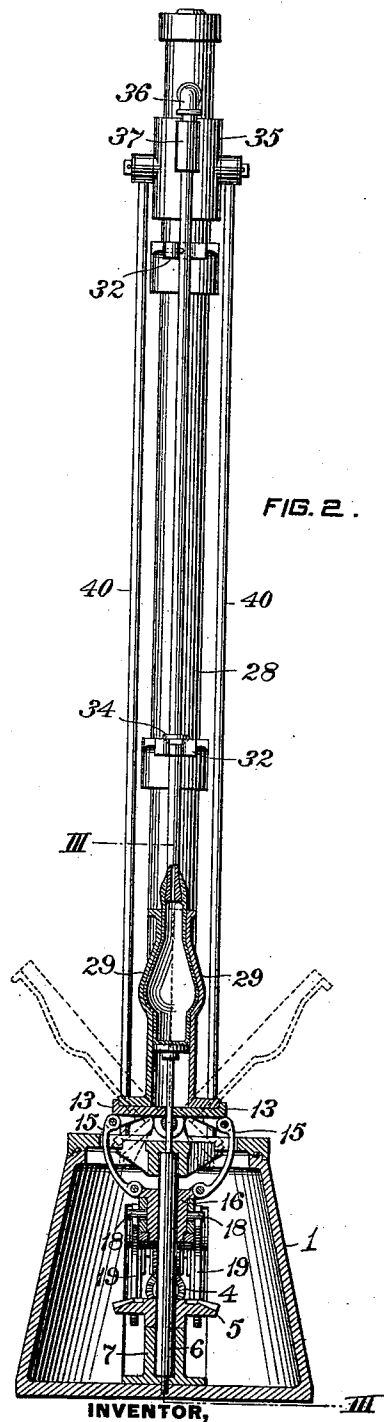

FIG. 2.

WITNESSES:

Chas. F. Miller
J. E. Gaither

INVENTOR,

Charles H. W. Ruhe
by Damon S. Wolcott

Att'y.

No. 635,392.

Patented Oct. 24, 1899.

C. H. W. RUHE.
MACHINE FOR BLOWING GLASS.

(Application filed Mar. 9, 1899.)

(No Model.)

3 Sheets—Sheet 2.

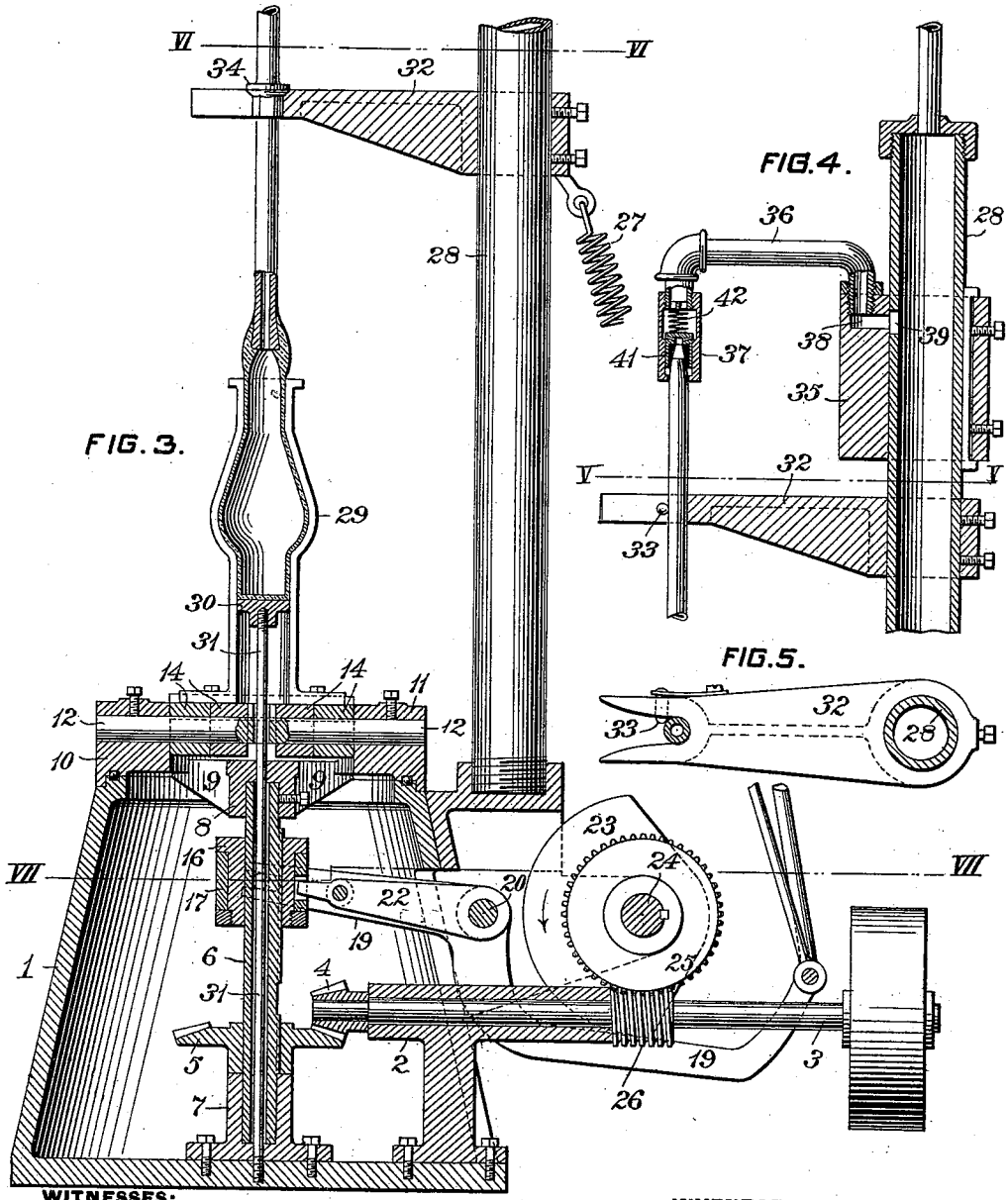
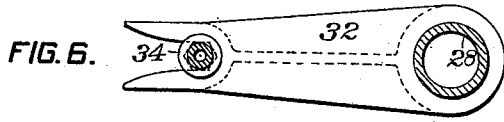

FIG. 4.

FIG. 5.

WITNESSES:

Chas. F. Miller.
J. E. Gaither

INVENTOR,
Charles H. W. Ruhe
by *Danni S. Wolcott*
Att'y.

No. 635,392.

Patented Oct. 24, 1899.

C. H. W. RUHE.
MACHINE FOR BLOWING GLASS.

(Application filed Mar. 9, 1899.)

(No Model.)

3 Sheets—Sheet 3.

FIG. 7.

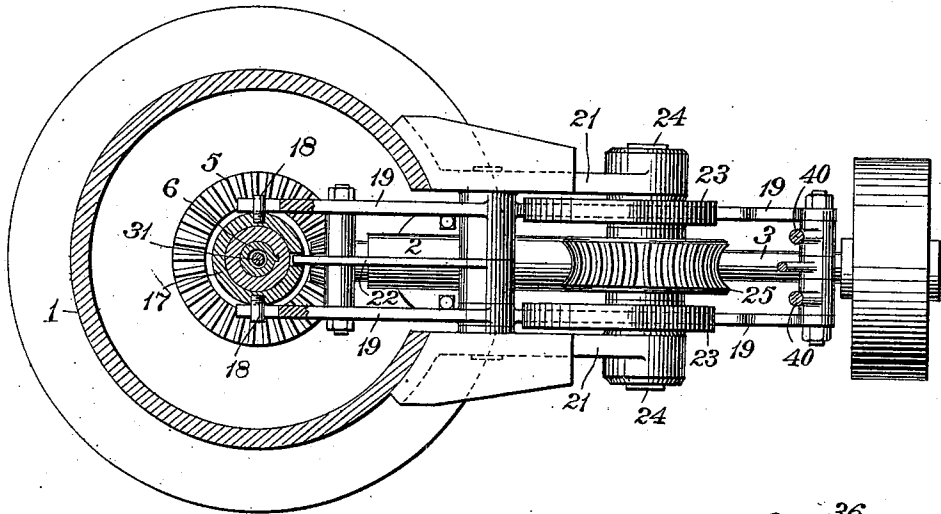

FIG. 8.

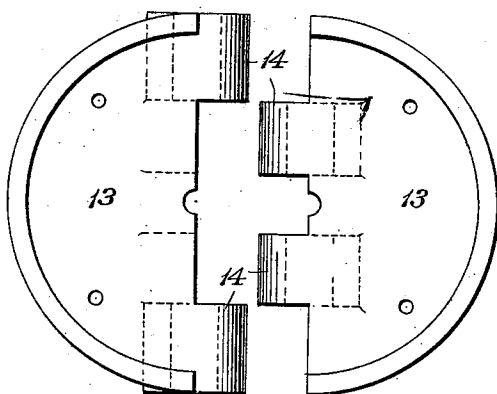
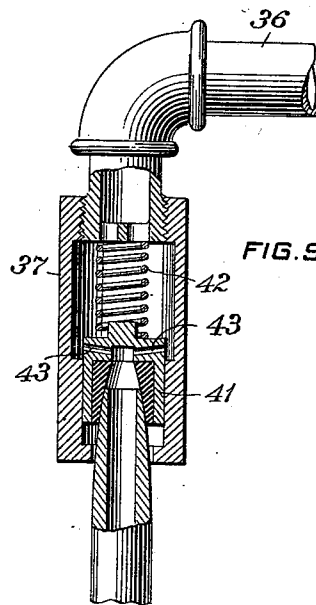

FIG. 9.



WITNESSES:

Chas. F. Miller.
J. C. Gaicher.

INVENTOR,

Charles H. W. Ruhe
by Sammi S. Walcott

Att'y.

UNITED STATES PATENT OFFICE.

CHARLES H. W. RUHE, OF PITTSBURG, PENNSYLVANIA.

MACHINE FOR BLOWING GLASS.

SPECIFICATION forming part of Letters Patent No. 635,392, dated October 24, 1899.

Application filed March 9, 1899. Serial No. 708,359. (No model.)

To all whom it may concern:

Be it known that I, CHARLES H. W. RUHE, a citizen of the United States, residing at Pittsburg, in the county of Allegheny and State of Pennsylvania, have invented or discovered certain new and useful Improvements in Machines for Blowing Glass, of which improvements the following is a specification.

The invention described herein relates to certain improvements in machines for the manufacture of glassware, and has for its object a construction of mechanism whereby continuously-rotating mold-sections may be closed around a body of glass supported by a stationary blowpipe and the latter simultaneously connected to a source of fluid under pressure.

In general terms the invention consists in the construction and combination substantially as hereinafter more fully described and claimed.

In the accompanying drawings, forming a part of this specification, Figure 1 is a side elevation of my improved machine. Fig. 2 is a sectional elevation of the same, the plane of section being indicated by the line II II, Fig. 1. Fig. 3 is a sectional elevation of the lower portion of the machine on an enlarged scale, the plane of section being indicated by the line III III, Fig. 2. Fig. 4 is a sectional view of the upper portion of the machine. Figs. 5 and 6 are plan views of the supporting-arms. Fig. 7 is a sectional plan view, the plane of section being indicated by the line VII VII, Fig. 3. Fig. 8 is a plan view of the mold-supporting plates, and Fig. 9 is a sectional detail view of the coupling mechanism for connecting the blowpipe to the fluid-pressure supply.

In the practice of my invention the supporting base or shell is preferably made conical in shape and has a bearing 2 for the driving-shaft 3 formed integral therewith, said bearing extending through the side of the shell. A beveled pinion 4 is keyed on the inner end of the shaft 3 and intermeshes with a correspondingly-shaped pinion 5 on the tubular shaft 6, which has its lower end supported in the step-bearing 7, formed on or secured to the base 1. The hub 8 of the turn-table is secured on the upper end of the tubular shaft and is connected by radial arms 9 to the rim

10 of said table, which is mounted on the upper end of the base or shell. In order to insure the easy movement of the table, anti-friction-rollers are interposed between it and the base. The turn-table is provided with sockets 11 for the reception of the pintle 12, which is held from movement in the sockets by set-screws or other suitable means. Plates or leaves 13, provided with sleeves 14, are loosely mounted on the pintle between the sockets and over the open portion of the turn-table, so that the plates or leaves may turn down into the spaces between the radial arms 9. The leaves or plates are connected by arms 15, which are preferably bowed to permit of some resilience, to a block 16, so mounted on the tubular shaft 6 as to rotate therewith and to be free to move vertically along it. This block is grooved for the reception of collar 17, provided with trunnions 18, adapted to engage slots in the ends of levers 19, which are loosely mounted on a shaft 20, secured in flanges 21, extending from the base or shell. An arm 22 is loosely mounted at one end on the shaft 20, while its other end engages a slot in the collar 17, so as to prevent any rotation of the latter with the block 16. The arm 22 and the inner arms of the levers 19 are preferably secured together and properly spaced by a bolt and interposed sleeve-sections arranged around the bolt. The outer portions of the levers are depressed to raise the block 16 and the plates or leaves 13 by means of cams 23, secured on a shaft 24, on which is keyed the worm-wheel 25, intermeshing with the worm 26 on the driving-shaft 3. The levers are held in contact with the cams by a spring 27, having one end connected to the post or standard 28 and the opposite end to the bolt passing through the outer ends of the levers.

The mold-sections 29 are detachably secured to the leaves or plates and are moved by them to and from closed position. In order to avoid the use of different lengths of blowpipe or an adjustment of the blowing-head with different sizes of molds, the latter when short articles are to be formed are provided with cylindrical extensions at their lower ends, the extensions being so proportioned that the upper or matrix portion of the mold will always have the same relation

to the blowpipe regardless of the size of the article to be formed. In other words, the mold-sections are made of the same length. The bottom of the shaping-matrix is formed
 5 by a disk 30, supported independently of the mold-sections 29 by a rod 31, which extends down through a transverse hole in the pintle 12 and through the tubular shaft 6 and bears at its lower end on the base or shell. This
 10 construction permits, by the use of rods of varying lengths, the supporting of the disk 30 at different heights, in accordance with the lengths of the matrix in the mold-sections. The disk 30 is detachably secured to the upper
 15 end of the rod 31, so that varying sizes of disks may be employed with varying sizes of molds.

A hollow post or standard 28 is secured to the base or shell 1, and arms 32, having their
 20 outer ends forked, are secured on the post at suitable distances apart. One or all of these arms are provided with spring-actuated pins 33, which project across the slot in the ends of the arms, so as to hold the blowpipe in
 25 position, as shown in Fig. 5. It is preferred to so shape the inner ends of the pins that they may be forced out by the blowpipe when the latter is pushed or pulled laterally. In order to hold the blowpipe from rotation, the
 30 external wall of the latter at those points which enter the forks in the arms 32 is made angular in cross-section and the inner ends of the forks are similarly shaped, as shown in Fig. 6. The blowpipe is held in proper
 35 position vertically by a collar 34 on the pipe resting on one of the arms 32, as shown in Fig. 3.

A sleeve or hollow block 35 is movably mounted in the post or standard 28 and is connected by a hollow arm 36 with the valve-shell 37. This hollow arm is connected by a
 40 passage 38 with a port 39 in the hollow post or standard, into which air under pressure is forced by any suitable means. The sleeve or block 35 is shifted to move the valve-head
 45 onto the upper end of the blowpipe and to bring the passage 38 into line with the port 39 by the levers 19, which have their outer ends connected to said sleeve by rods 40, as shown in Figs. 1 and 2.

The valve-head consists of a shell 37, secured to the outer end of the arm 36, and an inverted-cup-shaped valve 41, fitting in the contracted lower portion of the shell. The valve is normally held in the contracted
 55 position by a spring 42, bearing at its ends against the valve and a suitable stationary abutment. When the blowpipe is in operative position, the lowering of the block 35 will force the valve over the tapering end of
 60 the blowpipe, and the continued movement of the block will move the shell down over the valve sufficiently far to uncover the lateral ports 43, thereby permitting fluid-pressure to flow into the blowpipe, the passage
 65 38 of the block having been brought into register with the port 39 by the movement of the block. In order to form a tight joint between

the blowpipe and valve, the latter has a lining of rubber or other suitable material.

As the several operations of the machine—
i. e., closing the mold, lowering the valve-shell onto the blowpipe, revolving the mold,
 raising the valve shell or head, and opening the mold—are performed continuously and
 in due sequence, the attendant has only to
 place the blowpipe with its gather of glass
 in forks on the supporting-arms when the
 mold is open and then when the cycle of operations is completed and the mold opened to
 remove the blowpipe and completed article.

If the attendant fails to insert a blowpipe at the commencement of a cycle, no injury is done nor is any air lost, as the valve 41 is not shifted except by the end of a blowpipe held in proper position by the arms 32.

I claim herein as my invention—

1. In a glass-blowing machine, the combination of movable mold-sections, means for continuously rotating said sections, means for opening and closing the sections during their
 rotation, and means for holding a blowpipe stationary in proper relation to the mold-sections, substantially as set forth.

2. In a glass-blowing machine, the combination of movable mold-sections, means for
 continuously rotating said sections, means for opening and closing the mold-sections, means for holding the blowpipe stationary, and means for connecting the blowpipe to a source of fluid under pressure operative simultaneously with the closing of the mold, substantially as set forth.

3. In a glass-blowing machine, the combination of pivotally-mounted plates or leaves, mold-sections detachably secured to said
 leaves or plates, a disk adapted to form the bottom of the mold and a removable support therefor, substantially as set forth.

4. In a glass-blowing machine, the combination of a turn-table, mold-sections pivotally
 mounted on the turn-table, a movable block, arms connecting the block to the mold-sections, and a common means for simultaneously rotating the turn-table and raising and lowering the block during the rotation of the
 table, substantially as set forth.

5. In a glass-blowing machine, the combination of movable mold-sections, a hollow post or standard provided with a port, a block movable on the post, a valve-head carried by
 the block, a valve adapted to be unseated by the blowpipe when the block is lowered, the block having a passage adapted to be connected to the port in the standard, supports for the blowpipe, and means for simultaneously rotating and opening, and closing the mold-sections and shifting the block, substantially as set forth.

In testimony whereof I have hereunto set my hand.

CHARLES H. W. RUHE.

Witnesses:

DARWIN S. WOLCOTT,
 F. E. GAITHER.