



(86) Date de dépôt PCT/PCT Filing Date: 2009/12/21  
 (87) Date publication PCT/PCT Publication Date: 2010/07/01  
 (85) Entrée phase nationale/National Entry: 2011/06/21  
 (86) N° demande PCT/PCT Application No.: US 2009/068965  
 (87) N° publication PCT/PCT Publication No.: 2010/075267  
 (30) Priorités/Priorities: 2008/12/22 (US12/341,985);  
 2009/03/13 (US12/403,955)

(51) Cl.Int./Int.Cl. *C03C 3/087* (2006.01),  
*C03B 5/04* (2006.01), *C03B 5/235* (2006.01),  
*C03B 7/06* (2006.01), *C03C 13/00* (2006.01),  
*C03C 3/085* (2006.01), *C03C 3/091* (2006.01),  
*F23C 5/02* (2006.01), *F23D 14/22* (2006.01)

(71) Demandeur/Applicant:  
 OCV INTELLECTUAL CAPITAL, LLC, US

(72) Inventeurs/Inventors:  
 MCGINNIS, PETER BERNARD, US;  
 HOFMANN, DOUGLAS, US;  
 BAKER, DAVID, US;  
 WINGERT, JOHN, US;  
 BEMIS, BYRON, US

(74) Agent: SMART & BIGGAR

(54) Titre : PROCEDE DE FABRICATION DE FIBRES DE VERRE DE HAUTE RESISTANCE PAR FUSION DIRECTE, ET PRODUITS FORMES AVEC CES FIBRES  
 (54) Title: METHOD OF MANUFACTURING HIGH STRENGTH GLASS FIBERS IN A DIRECT MELT OPERATION AND PRODUCTS FORMED THERE FROM

FIG. 1

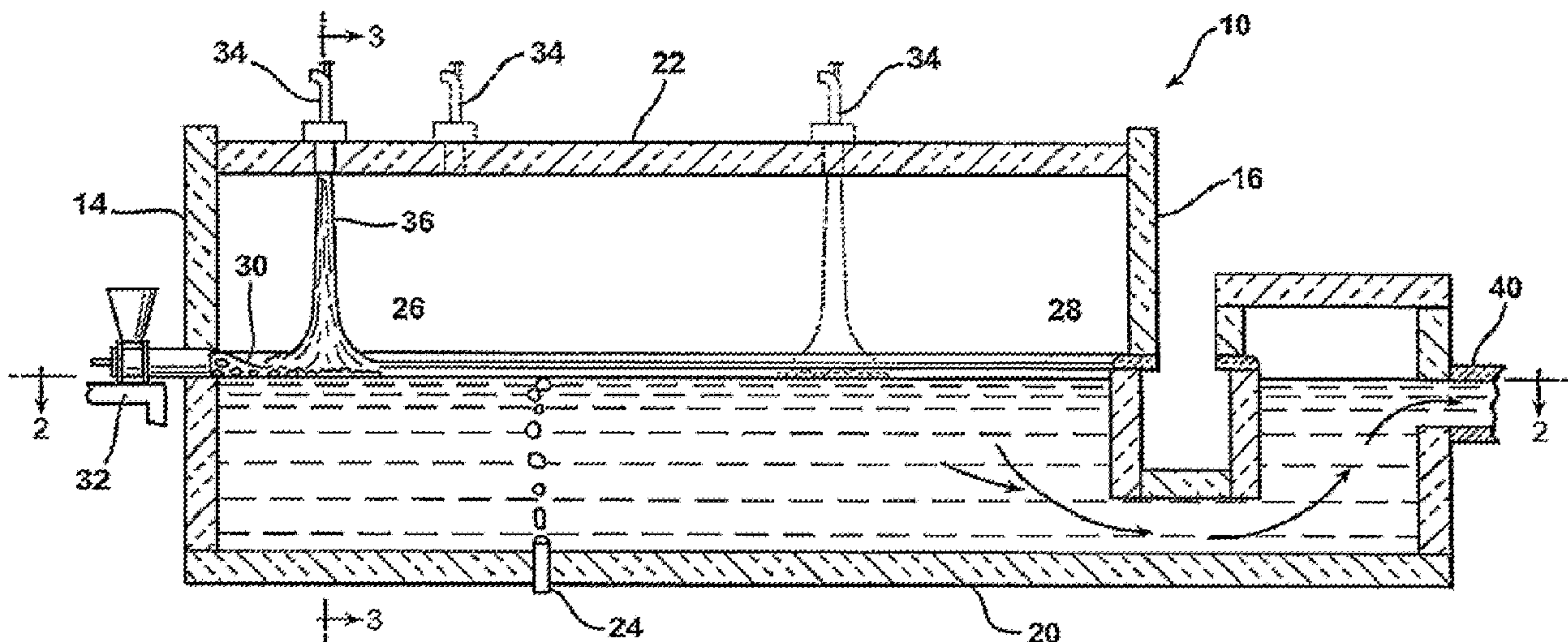

(57) Abrégé/Abstract:

A method of forming high strength glass fibers in a glass melter substantially free of platinum or other noble metal materials, products made there from and batch compositions suited for use in the method are disclosed. One glass composition for use in the present invention includes 50-75 weight % SiO<sub>2</sub>, 13-30 weight % Al<sub>2</sub>O<sub>3</sub>, 5-20 weight % MgO, 0- 10 weight % CaO, 0 to 5 weight % R<sub>2</sub>O where R<sub>2</sub>O is the sum of Li<sub>2</sub>O, Na<sub>2</sub>O and K<sub>2</sub>O, has a higher fiberizing temperature, e.g. 2400 - 2900° F (1316 - 1593 ° C) and/or a liquidus temperature that is below the fiberizing temperature by as little as 45 ° F (25° C). Another glass composition for use in the method of the present invention is up to about 64-75 weight percent SiO<sub>2</sub>, 16-24 weight percent Al<sub>2</sub>O<sub>3</sub>, 8-12 weight percent MgO and 0.25-3 weight percent R<sub>2</sub>O, where R<sub>2</sub>O equals the sum of Li<sub>2</sub>O, Na<sub>2</sub>O and K<sub>2</sub>O, has a fiberizing temperature less than about 2650° F (1454 ° C), and a ΔT of at least 80° F (45 ° C). A forehearth (12) for transporting molten glass from the

(57) **Abrégé(suite)/Abstract(continued):**

glass melter (10) to a forming position is disclosed. By using furnaces and/or forehearths substantially free of platinum or other noble metal materials, the cost of production of glass fibers is significantly reduced in comparison with the cost of fibers produced using a melting furnace lined with noble metal materials. High strength composite articles including the high strength glass fibers are also disclosed.

(12) INTERNATIONAL APPLICATION PUBLISHED UNDER THE PATENT COOPERATION TREATY (PCT)

(19) World Intellectual Property Organization  
International Bureau(43) International Publication Date  
1 July 2010 (01.07.2010)(10) International Publication Number  
**WO 2010/075267 A1**

## (51) International Patent Classification:

C03C 3/087 (2006.01) C03B 5/04 (2006.01)  
 C03C 3/085 (2006.01) C03B 5/235 (2006.01)  
 C03C 3/091 (2006.01) F23C 5/02 (2006.01)  
 C03C 13/00 (2006.01) F23D 14/22 (2006.01)  
 C03B 7/06 (2006.01)

43055 (US). **WINGERT, John** [US/US]; 179 Victoria Drive, 53-2, Granville, Ohio 43023 (US). **BEMIS, Byron** [US/US]; 10538 Blue Jay Road, 53-1, Newark, Ohio 43055 (US).

## (21) International Application Number:

PCT/US2009/068965

## (22) International Filing Date:

21 December 2009 (21.12.2009)

## (25) Filing Language:

English

## (26) Publication Language:

English

## (30) Priority Data:

12/341,985 22 December 2008 (22.12.2008) US  
 12/403,955 13 March 2009 (13.03.2009) US

(71) Applicant (for all designated States except US): **OCV INTELLECTUAL CAPITAL, LLC** [US/US]; One Owens Corning Parkway, Toledo, Ohio 43569 (US).

## (72) Inventors; and

(75) Inventors/Applicants (for US only): **MCGINNIS, Peter Bernard** [US/US]; 920 Ludwig Drive, Gahanna, Ohio 43230 (US). **HOFMANN, Douglas** [US/US]; 4260 Beaver Run Road, Hebron, Ohio 43025 (US). **BAKER, David** [US/US]; 770 Golden Dr., 53-2, Newark, Ohio

(74) Agents: **GRANT, Kathryn W.** et al.; Owens Corning S&T, Bldg. 21-0, 2790 Columbus Rd., Granville, Ohio 43023-1200 (US).

(81) Designated States (unless otherwise indicated, for every kind of national protection available): AE, AG, AL, AM, AO, AT, AU, AZ, BA, BB, BG, BH, BR, BW, BY, BZ, CA, CH, CL, CN, CO, CR, CU, CZ, DE, DK, DM, DO, DZ, EC, EE, EG, ES, FI, GB, GD, GE, GH, GM, GT, HN, HR, HU, ID, IL, IN, IS, JP, KE, KG, KM, KN, KP, KR, KZ, LA, LC, LK, LR, LS, LT, LU, LY, MA, MD, ME, MG, MK, MN, MW, MX, MY, MZ, NA, NG, NI, NO, NZ, OM, PE, PG, PH, PL, PT, RO, RS, RU, SC, SD, SE, SG, SK, SL, SM, ST, SV, SY, TJ, TM, TN, TR, TT, TZ, UA, UG, US, UZ, VC, VN, ZA, ZM, ZW.

(84) Designated States (unless otherwise indicated, for every kind of regional protection available): ARIPO (BW, GH, GM, KE, LS, MW, MZ, NA, SD, SL, SZ, TZ, UG, ZM, ZW), Eurasian (AM, AZ, BY, KG, KZ, MD, RU, TJ, TM), European (AT, BE, BG, CH, CY, CZ, DE, DK, EE, ES, FI, FR, GB, GR, HR, HU, IE, IS, IT, LT, LU, LV, MC, MK, MT, NL, NO, PL, PT, RO, SE, SI, SK, SM, TR), OAPI (BF, BJ, CF, CG, CI, CM, GA, GN, GQ, GW, ML, MR, NE, SN, TD, TG).

[Continued on next page]

(54) Title: METHOD OF MANUFACTURING HIGH STRENGTH GLASS FIBERS IN A DIRECT MELT OPERATION AND PRODUCTS FORMED THERE FROM

FIG. 1

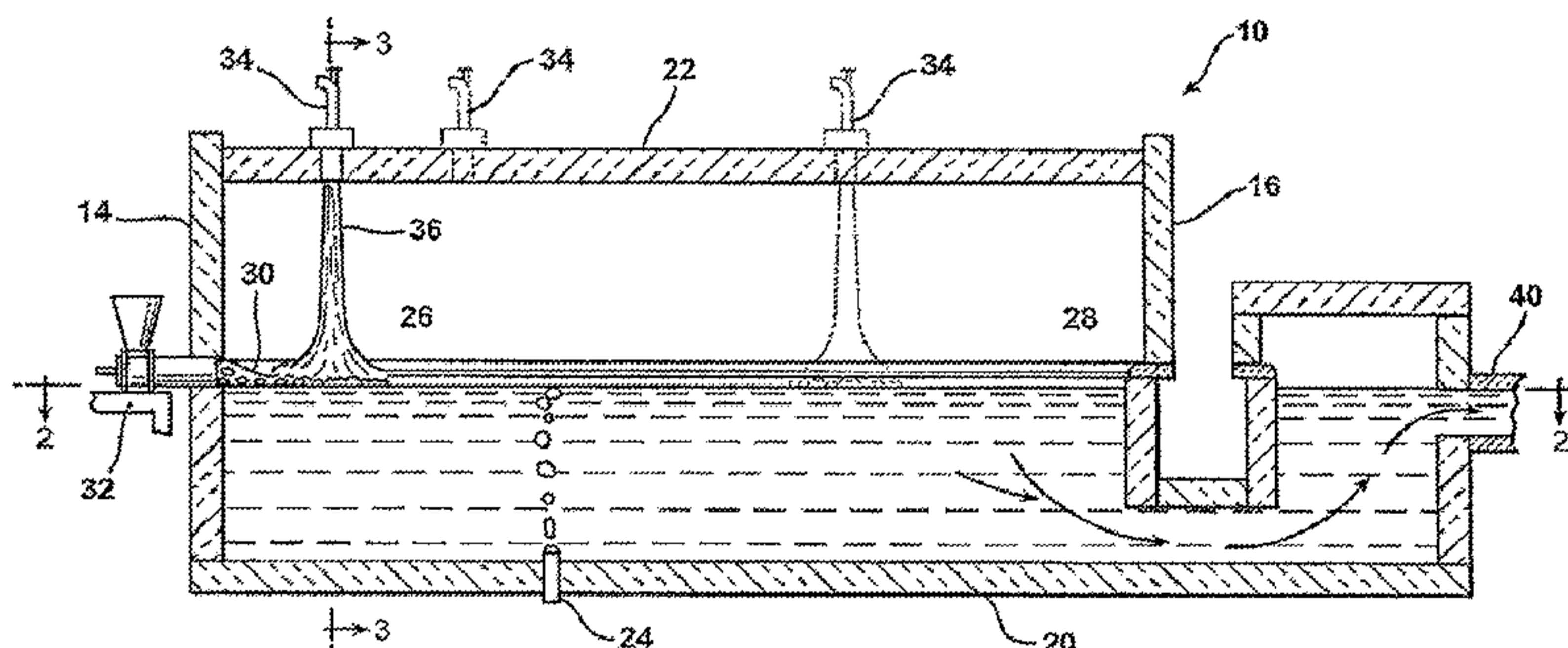

(57) Abstract: A method of forming high strength glass fibers in a glass melter substantially free of platinum or other noble metal materials, products made there from and batch compositions suited for use in the method are disclosed. One glass composition for use in the present invention includes 50-75 weight % SiO<sub>2</sub>, 13-30 weight % Al<sub>2</sub>O<sub>3</sub>, 5-20 weight % MgO, 0-10 weight % CaO, 0 to 5 weight % R<sub>2</sub>O where R<sub>2</sub>O is the sum of Li<sub>2</sub>O, Na<sub>2</sub>O and K<sub>2</sub>O, has a higher fiberizing temperature, e.g. 2400 - 2900° F (1316 - 1593 ° C) and/or a liquidus temperature that is below the fiberizing temperature by as little as 45 ° F (25° C). Another glass composition for use in the method of the present invention is up to about 64-75 weight percent SiO<sub>2</sub>, 16-24 weight percent Al<sub>2</sub>O<sub>3</sub>, 8-12 weight percent MgO and 0.25-3 weight percent R<sub>2</sub>O, where R<sub>2</sub>O equals the sum of Li<sub>2</sub>O, Na<sub>2</sub>O and K<sub>2</sub>O, has a fiberizing temperature less than about 2650° F (1454 ° C), and a ΔT of at least 80° F (45 ° C). A forehearth (12) for transporting molten glass from the glass melter (10) to a forming position is disclosed. By using furnaces and/or forehearths substantially free of platinum or other noble metal materials, the cost of production of glass fibers is significantly reduced in comparison with the cost of fibers produced using a melting furnace lined with noble metal materials. High strength composite articles including the high strength glass fibers are also disclosed.

WO 2010/075267 A1

**WO 2010/075267 A1** 

---

**Published:**

— with international search report (Art. 21(3))

— before the expiration of the time limit for amending the claims and to be republished in the event of receipt of amendments (Rule 48.2(h))

**METHOD OF MANUFACTURING HIGH STRENGTH GLASS FIBERS IN A  
DIRECT MELT OPERATION AND PRODUCTS FORMED THERE FROM**

**TECHNICAL FIELD AND INDUSTRIAL APPLICABILITY OF THE INVENTION**

5

The present invention is generally directed to a method of manufacturing continuous glass fibers for use in high-strength applications and products made there from, such as ballistic armor, pressure vessels, structural aerospace materials, structural marine materials, and structural materials for wind energy such as windmill masts and blades.

10

**BACKGROUND OF THE INVENTION**

Fiberglass reinforced composite materials have been available for use in marine and aerospace materials for some time. Other fiber materials such as carbon and aramid fibers are available for use, although at substantially higher cost. The articles of the present invention may use any known manufacturing method, including compression molding, laminating, spray up, hand laying, prefabricated lay-up (prepreg), compression molding, vacuum bag molding, pressure bag molding, press molding, transfer molding, vacuum assisted resin transfer molding, pultrusion molding, filament winding, casting, autoclave molding, centrifugal casting resin transfer and continuous casting. The properties of the composite are controlled by the fibers and the resin, and synergy between the two, that produces material properties unavailable from the individual materials.

A number of resins are useful in the manufacture of composite articles including polyester resin, vinylester resin and epoxy resin. Polyester resin is suitable for a number of situations. Vinylester resin has lower viscosity precure and more flexible postcure than polyester resin and is typically more resistant to degradation. Epoxy resin is typically transparent when cured. Epoxy resin is a polyether resin formed by the polymerization bisphenol A, bisphenol F, bisphenol C, and compounds of similar structure with epichlorohydrin resulting in the formation of the reactive oxirane linkage. Epoxy resins may react with a variety of curing agents, including amines, anhydrides, mercaptans, polyesters to form an infusible solid. The reaction is a condensation reaction typically does not create by-products. Cured epoxy resins have high strength, and low shrinkage

30

during curing. They are used as coatings, adhesives, castings, composites, or foam. Epoxy resins are also desirable for use in high strength applications as a structural matrix material or as a structural glue. Phenolics are thermosetting resins formed by the condensation of phenol, or of a phenol derivative, with an aldehyde, typically a formaldehyde. Phenolics are used chiefly in the manufacture of paints and plastics. Other specific high strength modulus resins include bismaleimide, poly- amide, vinyl ester phenolic, ethylene-acrylate or methacrylate copolymers, high strength medium modulus thermoplastics such as an ionomer (i.e. crosslinked ethylene-methyl acrylate or methyl methacrylate copolymer), polycarbonate, polyurethane, nylon, aramid, modified epoxies.

10           The most common high strength glass composition for making continuous glass fiber strands is "S-Glass." S-Glass is a family of glasses composed primarily of the oxides of magnesium, aluminum, and silicon with a chemical composition that produces glass fibers having a higher mechanical strength than E-Glass fibers. A commonly used member of the S-Glass family is known as S2-Glass. S2-Glass includes approximately 65 weight % SiO<sub>2</sub>, 25 weight % Al<sub>2</sub>O<sub>3</sub>, and 10 weight % MgO. S-glass has a composition that was originally designed to be used in high-strength applications such as ballistic armor.

20           R-Glass is a family of glasses that are composed primarily of the oxides of silicon, aluminum, magnesium, and calcium with a chemical composition that produces glass fibers with a higher mechanical strength than E-Glass fibers. R-Glass has a composition that contains approximately 58 - 60 weight % SiO<sub>2</sub>, 23.5 - 25.5 weight % Al<sub>2</sub>O<sub>3</sub>, 14 - 17 weight % CaO plus MgO, 0 % B<sub>2</sub>O<sub>3</sub>, 0 % F<sub>2</sub> and less than 2 weight % miscellaneous components. R-Glass contains more alumina and silica than E-Glass and requires higher melting and processing temperatures during fiber forming. Typically, the melting and processing temperatures for R-Glass are at least 160° C higher than those for E-Glass. This increase in processing temperature typically requires the use of a high-cost platinum-lined melter. In addition, the close proximity of the liquidus temperature to the forming temperature in R-Glass requires that the glass be fiberized at a higher temperature than E-Glass.

30           Other known high-strength glass compositions can be found in U.S. patent application Ser. No. 11/267,739 entitled "Composition for High Performance Glass, High

Performance Glass Fibers and Articles Therefrom”, published as U.S. Patent Application Pub. No. 2008/0009403.

Both R-Glass and S-Glass are produced by melting the constituents of the compositions in a platinum-lined melting container. The costs of forming R-Glass and S-Glass fibers are dramatically higher than E-Glass fibers due to the cost of producing the fibers in such melters. Thus, there is a need in the art for methods of forming glass compositions useful in the formation of high performance glass fibers from a direct-melt process in a furnace substantially free of platinum or other noble metal materials and products formed there from.

10

#### SUMMARY OF THE INVENTION

The present invention includes a process for producing refined glass from a raw glass batch with a glass melter substantially free of platinum or other noble metal materials. The process includes charging a raw glass batch to a melting zone of a glass melter, melting the raw glass batch within the melting zone and forming continuous fibers from the melt. The present invention also includes fibers formed by such a method, and products made from such fibers.

In one embodiment the invention comprises a method of forming high strength glass fibers in a continuous system having a furnace, a forehearth, and a bushing. The method includes providing a glass melting furnace for receiving glass batch and discharging molten glass, and lining at least a portion of the furnace with a material substantially free of noble metal materials to form a furnace glass contact surface. Glass batch is supplied to the furnace, the glass batch being capable of forming a fiberizable molten glass having a fiberizing  $\Delta T$  greater than 45 °F (25 °C) and for producing glass fibers having a composition comprising about 50 - about 75 weight percent  $\text{SiO}_2$ ; about 15 - about 30 weight percent  $\text{Al}_2\text{O}_3$ ; about 5 - about 20 weight percent  $\text{MgO}$ ; about 0 - about 10 weight percent  $\text{CaO}$ ; and about 0 - about 5 weight percent  $\text{R}_2\text{O}$ , where  $\text{R}_2\text{O}$  equals the sum of  $\text{Li}_2\text{O}$ ,  $\text{Na}_2\text{O}$  and  $\text{K}_2\text{O}$ . The glass batch is melted in the furnace by providing heat from a furnace heat source, such as oxy-fuel burners, forming a pool of molten glass in contact with the furnace glass contact surface. A forehearth is provided for transporting molten glass from the furnace to the bushing, and at least a portion of the

30

forehearth is lined with a material substantially free of noble metal materials to form a forehearth glass contact surface. The molten glass is transported in the forehearth while heat is provided from a forehearth heat source and flows through the forehearth along a substantially horizontal flow path formed by the forehearth glass contact surface. The molten glass is discharged from the forehearth into the bushing at a temperature of about 2400 °F (1316 °C) to about 2900 °F (1593 °C) and a predetermined viscosity (e.g. about 1000 poise), and is formed into continuous fibers.

The invention includes a method of manufacturing a glass composition for the formation of continuous glass fibers and products made there from that are suitable for use in high-strength applications. Compositions useful in the present invention may be inexpensively formed into glass fibers using low-cost, direct melting in a furnace substantially free of platinum or other noble metal materials, including alloys thereof.

One composition useful in the present invention includes 64-75 weight % SiO<sub>2</sub>, 16-26 weight % Al<sub>2</sub>O<sub>3</sub>, 8-12 weight % MgO and 0 to 3.0 weight % R<sub>2</sub>O where R<sub>2</sub>O is the sum of Li<sub>2</sub>O, Na<sub>2</sub>O and K<sub>2</sub>O.

Another composition useful in the present invention includes 64-75 weight % SiO<sub>2</sub>, 16-24 weight % Al<sub>2</sub>O<sub>3</sub>, 8-12 weight % MgO and 0.25 to 3.0 weight % R<sub>2</sub>O where R<sub>2</sub>O is the sum of Li<sub>2</sub>O, Na<sub>2</sub>O and K<sub>2</sub>O. In certain embodiments, the glass composition is composed of 64-70 weight % SiO<sub>2</sub>, 17-22 weight % Al<sub>2</sub>O<sub>3</sub>, 9-12 weight % MgO and 1.75-3.0 weight % R<sub>2</sub>O where R<sub>2</sub>O is the sum of Li<sub>2</sub>O, Na<sub>2</sub>O and K<sub>2</sub>O. In another embodiment, a glass composition useful in the present invention is composed of 64-70 weight % SiO<sub>2</sub>, 17-22 weight % Al<sub>2</sub>O<sub>3</sub>, 9-12 weight % MgO and 1.75-3.0 weight % Li<sub>2</sub>O.

Still another composition useful in the present invention includes 50-75 weight % SiO<sub>2</sub>, 13-30 weight % Al<sub>2</sub>O<sub>3</sub>, 5-20 weight % MgO, 0-10 weight % CaO, 0 to 5 weight % R<sub>2</sub>O where R<sub>2</sub>O is the sum of Li<sub>2</sub>O, Na<sub>2</sub>O and K<sub>2</sub>O.

In certain exemplary embodiments, the composition does not contain more than about 5.0 weight % of compounds such as CaO, P<sub>2</sub>O<sub>5</sub>, ZnO, ZrO<sub>2</sub>, SrO, BaO, SO<sub>3</sub>, F, B<sub>2</sub>O<sub>3</sub>, TiO<sub>2</sub>, Fe<sub>2</sub>O<sub>3</sub>, CeO<sub>2</sub> and BeO<sub>2</sub>. In other exemplary embodiments the composition is devoid of intentionally added CeO<sub>2</sub> and BeO<sub>2</sub>. In still other exemplary embodiments, the composition preferably does not contain more than about 4 weight % of compounds or halogens such as ZnO, SO<sub>3</sub>, Fluorine, B<sub>2</sub>O<sub>3</sub>, TiO<sub>2</sub>, ZrO<sub>2</sub> and Fe<sub>2</sub>O<sub>3</sub>.



In some exemplary embodiments, the desired properties of the high performance fibers manufactured by the present invention include a fiberizing temperature of less than 2650 ° F (1454 ° C) and a liquidus temperature that is preferably below the fiberizing temperature by at least 80° F (44 ° C), more preferably by at least about 120° F (67 ° C), and most preferably by at least about 150° F (83 ° C).

In other exemplary embodiments, the desired properties of the high performance fibers manufactured by the present invention include a fiberizing temperature of 2400 – 2900 ° F (1316 - 1593 ° C) and a liquidus temperature that is below the fiberizing temperature by at least 45 ° F (25 ° C).

The present invention also provides a structural part having improved structural properties with decreased costs and improved manufacturability. The direct melt formation of the continuous glass fibers uses low-cost melting in a glass melter substantially free of platinum or other noble metal materials. The relatively low fiberizing temperature of the glass fibers used in the high-strength applications of the present invention allows improved fiber processing at decreased cost. The articles of the present invention are typically formed by compression molding, laminating, spray up, hand laying, prefabricated lay-up (prepreg), compression molding, vacuum bag molding, pressure bag molding, press molding, transfer molding, vacuum assisted resin transfer molding, pultrusion molding, filament winding, casting, autoclave molding, centrifugal casting resin transfer or continuous casting.

The fibers produced and used in the present invention are substantially less expensive to make and also have good strength and density properties. The density of the fibers used in the present invention range between 2.434 – 2.520 g/cc, and more preferably 2.434 – 2.486 g/cc and have a measured modulus greater than 12.7 MPsi and a measured pristine fiber strength greater than 680 KPsi.

#### BRIEF DESCRIPTION OF THE DRAWINGS

FIG. 1 is a cross-sectional longitudinal view of a glass melting furnace useful with the method of the present invention;

FIG. 2 is a cross-sectional plan view of the glass melting furnace of FIG. 1 taken along line 2--2;

FIG. 3 is a cross-sectional view of the glass melting furnace of FIG. 1 taken along line 3--3 illustrating two burners adjacent the upstream end wall of the furnace;

5 FIG. 4 is an alternate cross-sectional plan view of the glass melting furnace of FIG. 1 taken along line 3--3 illustrating one burner adjacent the upstream end wall of the furnace; and

FIG. 5 is a side view, partially in cross section, of a bushing assembly/support structure arrangement for producing continuous glass filaments useful in  
10 the method of the present invention.

FIG. 6 is a top plan view in cross-section of an exemplary forehearth useful in the method of the present invention for transporting molten glass from the glass melting furnace to the bushing assembly/support.

FIG. 7 is a side elevation view in cross-section of another exemplary  
15 forehearth useful in the method of the present invention.

#### DETAILED DESCRIPTION AND PREFERRED EMBODIMENTS OF THE INVENTION

The present invention will now be described with occasional reference to the  
20 specific embodiments of the invention. This invention may, however, be embodied in different forms and should not be construed as limited to the embodiments set forth herein. Rather, these embodiments are provided so that this disclosure will be thorough and complete, and will fully convey the scope of the invention to those skilled in the art.

Unless otherwise defined, all technical and scientific terms used herein have the  
25 same meaning as commonly understood by one of ordinary skill in the art to which this invention belongs. The terminology used in the description of the invention herein is for describing particular embodiments only and is not intended to be limiting of the invention. As used in the description of the invention and the appended claims, the singular forms "a," "an," and "the" are intended to include the plural forms as well, unless the context  
30 clearly indicates otherwise.

Unless otherwise indicated, all numbers expressing quantities of ingredients, properties such as molecular weight, reaction conditions, and so forth as used in the specification and claims are to be understood as being modified in all instances by the term "about." Accordingly, unless otherwise indicated, the numerical properties set forth  
5 in the specification and claims are approximations that may vary depending on the desired properties sought to be obtained in embodiments of the present invention. Notwithstanding that the numerical ranges and parameters setting forth the broad scope of the invention are approximations, the numerical values set forth in the specific examples are reported as precisely as possible. Any numerical values, however, inherently contain  
10 certain errors necessarily resulting from error found in their respective measurements.

Fiberizing properties of the glass composition used to form the glass fibers of the present invention include the fiberizing temperature, the liquidus, and delta-T. Unless otherwise defined herein, the fiberizing temperature is defined as the temperature that corresponds to a viscosity of 1000 poise (log 3 temperature). One skilled in the art will  
15 recognize that other fiberizing temperatures may be defined, e.g. a fiberizing temperature may be defined as the temperature that corresponds to a viscosity of 316 poise (log 2.5 temperature).

As discussed in more detail below, in certain embodiments a lowered fiberizing temperature reduces the production cost of the fibers, allows for a longer bushing life,  
20 increases throughput, permits the glass to be melted in a melter substantially free of platinum or other noble metal materials, and reduces energy usage. For example, at a lower fiberizing temperature, a bushing operates at a cooler temperature and does not "sag" as quickly. Sag is a phenomenon that occurs in bushings that are held at an elevated temperature for extended periods of time. By lowering the fiberizing temperature, the sag  
25 rate of the bushing may be reduced and the bushing life can be increased. In addition, a lower fiberizing temperature allows for a higher throughput since more glass can be melted in a given period at a given energy input. As a result, production cost is reduced. In addition, a lower fiberizing temperature will also permit glass formed with the inventive method and composition to be melted in a refractory-lined melter, or a melter with  
30 externally cooled walls, since both its melting and fiberizing temperatures are below the upper use temperatures of many commercially available refractories or other materials when external cooling is supplied.

The liquidus is defined as the highest temperature at which equilibrium exists between liquid glass and its primary crystalline phase. At all temperatures above the liquidus, the glass is free from crystals in its primary phase. At temperatures below the liquidus, crystals may form.

5 Another fiberizing property is delta-T ( $\Delta T$ ), which is defined as the difference between the fiberizing temperature and the liquidus. A larger  $\Delta T$  offers a greater degree of flexibility during the formation of the glass fibers and helps to inhibit devitrification of the glass (that is, the formation of crystals within the melt) during melting and fiberizing. Increasing the  $\Delta T$  also reduces the production cost of the glass fibers by allowing for a  
10 greater bushing life and by providing a wider process window for forming fibers.

Conversely a higher fiberizing temperature and/or a smaller  $\Delta T$  means the fiber formation process is less forgiving, being more sensitive to temperature variations, cold spots and slow moving glass.

The glass compositions employed in the present invention are advantageously  
15 suitable for melting in a furnace or glass melter substantially free of platinum or other noble metal materials and alloys thereof, including traditional, commercially available refractory-lined glass melters, and commercially available glass melters lined with externally cooled walls, e.g. water-cooled walls.

Starting batch components typically include  $\text{SiO}_2$  (ground silica sand), and  $\text{Al}_2\text{O}_3$   
20 (calcined alumina),  $\text{Li}_2\text{CO}_3$  (lithium carbonate),  $\text{H}_3\text{BO}_3$  (boric acid),  $\text{NaCaB}_5\text{O}_9 \cdot 8\text{H}_2\text{O}$  (ulexite),  $2\text{CaO} \cdot 3\text{B}_2\text{O}_3 \cdot 5\text{H}_2\text{O}$  (colemanite) as well as chain modifiers from source materials such as  $\text{MgCO}_3$  (magnesite),  $\text{CaCO}_3$  (limestone),  $\text{SrCO}_3$  (strontianite),  $\text{BaCO}_3$  (witherite),  $\text{ZrSiO}_4$  (zircon), and  $\text{Na}_2\text{CO}_3$  (natrite). One skilled in the art will appreciate that other starting materials may be used. Additional nonlimiting examples of suitable  
25 starting batch components include kaolinite ( $\text{Al}_2\text{Si}_2\text{O}_5(\text{OH})_4$ ), pyrophyllite ( $\text{Al}_2\text{Si}_4\text{O}_{10}(\text{OH})_2$ ), bauxite ( $\text{AlO}(\text{OH})$ ), wollastonite ( $\text{CaSiO}_3$ ), spodumene ( $\text{LiAlSi}_2\text{O}_6$ ), feldspar ( $\text{CaAl}_2\text{Si}_2\text{O}_8$ ), dolomite ( $\text{CaMg}(\text{CO}_2)_2$ ), lime ( $\text{CaO}$ ), dolomitic quicklime ( $\text{CaMgO}_2$ ), and hydrated lime ( $\text{Ca}(\text{OH})_2$ ).

#### Glass Melting Furnace

30 FIGS 1-4 depict a glass melting furnace (10) useful in the method of forming the glass fibers described herein and set forth in the examples and claims below. It may also

be desirable to use oxygen-fired heating within the melting furnace, as disclosed in US Patent No. 7,509,819 entitled "OXYGEN-FIRED FRONT END FOR GLASS FORMING OPERATION", inventors David J Baker et al., herein incorporated in its entirety by reference. The glass melting furnace (10) provides molten glass to a glass forehearth (12).

5 In one exemplary embodiment, the molten glass is composed of 50-75 weight % SiO<sub>2</sub>, 13-30 weight % Al<sub>2</sub>O<sub>3</sub>, 5-20 weight % MgO, 0-10 weight % CaO, 0 to 5 weight % R<sub>2</sub>O where R<sub>2</sub>O is the sum of Li<sub>2</sub>O, Na<sub>2</sub>O and K<sub>2</sub>O. This exemplary embodiment includes glass compositions having a higher fiberizing temperature, e.g. 2400 - 2900° F (1316 – 1593 ° C) and/or a liquidus temperature that is below the fiberizing temperature by as little  
10 as 45 ° F (25° C).

In another exemplary embodiment, the molten glass is composed of about 64-75 weight % SiO<sub>2</sub>, 16-26 weight % Al<sub>2</sub>O<sub>3</sub>, 8-12 weight % MgO and 0 to 3.0 weight % R<sub>2</sub>O where R<sub>2</sub>O is the sum of Li<sub>2</sub>O, Na<sub>2</sub>O and K<sub>2</sub>O.

In yet another exemplary embodiment, the molten glass is composed of about 64-  
15 75 weight % SiO<sub>2</sub>, 16-24 weight % Al<sub>2</sub>O<sub>3</sub>, 8-12 weight % MgO and 0.25 to 3.0 weight % R<sub>2</sub>O where R<sub>2</sub>O is the sum of Li<sub>2</sub>O, Na<sub>2</sub>O and K<sub>2</sub>O. A fiber formed in accordance with the method of this exemplary embodiment will have a fiberizing temperature of less than 2650 ° F (1454 ° C), and in certain embodiments less than about 2625° F (1458 ° C), in other embodiments less than about 2600° F (1427 ° C) and in certain embodiments less  
20 than about 2575° F (1413 ° C) and a liquidus temperature that is below the fiberizing temperature in certain embodiments by at least 80° F (44 ° C), and in other embodiments by at least about 120° F (67 ° C), and in yet other embodiments by at least about 150° F (83 ° C).

In still another exemplary embodiment, the molten glass is composed of 50-75  
25 weight % SiO<sub>2</sub>, 13-30 weight % Al<sub>2</sub>O<sub>3</sub>, 5-20 weight % MgO, 0-10 weight % CaO, 0 to 5 weight % R<sub>2</sub>O where R<sub>2</sub>O is the sum of Li<sub>2</sub>O, Na<sub>2</sub>O and K<sub>2</sub>O. This exemplary embodiment includes glass compositions having a liquidus temperature that is above the log 3 fiberizing temperature, i.e. a negative ΔT such as – 122 ° F (- 68° C). Such a composition may be fiberized at higher temperature, e.g. a log 2.5 fiberizing temperature  
30 corresponding to a viscosity of 316 poise.

In certain exemplary embodiments, the composition does not contain more than about 5.0 weight % of oxides or compounds such as CaO, P<sub>2</sub>O<sub>5</sub>, ZnO, ZrO<sub>2</sub>, SrO, BaO, SO<sub>3</sub>, Fluorine, B<sub>2</sub>O<sub>3</sub>, TiO<sub>2</sub>, Fe<sub>2</sub>O<sub>3</sub>, K<sub>2</sub>O, CeO<sub>2</sub> and BeO<sub>2</sub>. In other exemplary embodiments the composition is devoid of intentionally added CeO<sub>2</sub> and BeO<sub>2</sub>.

5 The fibers produced and used in the present invention are substantially less expensive to make and also have good strength and density properties. The density of the fibers used in the present invention range between 2.434 – 2.520 g/cc, and more preferably 2.434 – 2.486 g/cc. Further, the glass fibers of the present invention, in certain  
10 other embodiments, will have a pristine fiber strength in excess of 680 KPSI, and in certain other embodiments a strength in excess of about 700 KPSI, and in yet other embodiments a strength in excess of about 730 KPSI. Further, the glass fibers will advantageously have a modulus greater than 12.0 MPSI, and in certain embodiments greater than about 12.18  
15 MPSI, and in some embodiments greater than about 12.7 MPSI.

The method of the present invention is preferably performed using the glass  
15 melting furnace (10), which includes an elongated channel having an upstream end wall (14), a downstream end wall (16), side walls (18), a floor (20), and a roof (22). Each of the components of the glass melting furnace (10) are made from appropriate refractory materials such as alumina, chromic oxide, silica, alumina-silica, zircon, zirconia-alumina-silica, or similar oxide-based refractory materials, in particular the surfaces that are in  
20 contact with the molten glass. The roof (22) is shown generally as having an arcuate shape transverse to the longitudinal axis of the composition the channel; however, the roof may have any suitable design. The roof (22) is typically positioned between about 3-10 feet above the surface of the glass batch (30). The glass batch (30) is a mixture of raw materials used in the manufacture of glass in accordance with the present invention.

25 The glass melting furnace (10) may optionally include one or more bubblers (24) and/or electrical boost electrodes (not shown). The bubblers (24) and/or electrical boost electrodes increase the temperature of the bulk glass and increase the molten glass circulation under the batch cover.

Bubblers (24) and/or electrical boost electrodes may be particularly useful in the  
30 second and third exemplary embodiments, which include glass compositions having a higher fiberizing temperature, e.g. 2400 - 2900° F (1316 – 1593 ° C) and/or a low ΔT, e.g.

as low as 45 ° C (25 ° F), or even a negative  $\Delta T$  such as - 122 ° F (- 68° C), where the potential for devitrification is greater.

In addition, the glass melting furnace (10) may include two successive zones, an upstream melting zone (26) and a downstream refining zone (28). In the melting zone  
5 (26), the glass batch composition (30) may be charged into the furnace using a charging device (32) of a type well-known in the art.

In one suitable melter configuration, the glass batch material (30) forms a batch layer of solid particles on the surface of the molten glass in the melting zone (26) of the glass melting furnace (10). The floating solid batch particles of the glass batch  
10 composition (30) are at least partially melted by at least one burner (34) having a controlled flame shape and length mounted within the roof (22) of the glass melting furnace (10).

In one preferred embodiment, as shown in FIG. 1, the glass melting furnace (10) includes three burners (34). A single burner (34) is positioned upstream of two adjacently  
15 positioned downstream burners (34). However, it will be appreciated that any number of burners (34) may be positioned at any suitable location in the roof (22) of the furnace (10) over the batch to melt the glass batch (30). For example, two burners (34) may be positioned in a side-by-side relationship (FIG. 3) or a single burner may be used (FIG. 4).

It is to be noted that the burners (34) of glass melting furnace (10) may be arranged  
20 in the crown (roof) of the furnace, in the side walls, the end walls, submerged within the batch or molten glass, or in combinations thereof.

Other melters may be used without departing from the present invention. Suitable melters include Air-Gas melters, Oxygen-Gas melters, electrically heated melters, or any fossil fuel fired melter. It is possible to add electric boost or bubblers to any of the melting  
25 processes. It is also possible to include a separate refining zone (as shown in FIG. 1) or incorporate the refining zone into the main tank of the melter.

#### Forehearth Arrangement

The forehearth receives molten glass discharged from the glass melting furnace and transports the molten glass, discharging the molten glass in suitable condition to a  
30 forming position. The components of the forehearth may be lined with appropriate

refractory materials such as alumina, chromic oxide, silica, alumina-silica, zircon, zirconia-alumina-silica, or similar oxide-based refractory materials, in particular the surfaces that are in contact with the molten glass. Preferably such forehearth glass contact surfaces are lined with chromic oxide materials, zircon or combinations thereof.

5 For compositions having a fiberizing temperature of less than 2650 ° F (1454 ° C) and a liquidus temperature that is below the fiberizing temperature by at least 80° F (44 °C), a conventional forehearth may be used.

For other compositions where the fiberizing temperature is high and/or the  $\Delta T$  is low, other forehearth arrangements may be helpful in promoting an isothermal condition  
10 in the molten glass, thereby preventing devitrification. For example, transporting the molten glass through the forehearth at a shallow depth (D), e.g. less than about 8 inches, or preferably less than about 3.5 inches, will improve transmission of heat by radiation throughout the molten glass. Installed oxygen-fuel fired burners are particularly useful as a forehearth heat source in this regard. A typical oxygen-fuel firing system is supplied by  
15 BH-F (Engineering) Ltd. of England. As defined here, oxygen-fuel fired burners are burners that use oxygen (e.g., typically 90 to 99 percent purity with an impurity being a combination of nitrogen and argon) in a high purity as an oxidant, instead of ambient air used in air-fuel burners, and fossil fuel for a combustible hydrocarbon supply, but may include burners using oxygen-enriched air (e.g. 30 to 90 percent purity). The flame  
20 temperature of an oxygen-gas burner is about 4200 to about 5200 ° F (about 2315 to about 2871 ° C). At this temperature, the flame and products of combustion radiate energy at wavelengths that the molten glass can absorb. This promotes uniform glass temperature horizontally on the surface of the molten glass and vertically through the molten glass.

Air-fuel burners may also be used a forehearth heat source, particularly when  
25 installed with a very tight spacing, e.g. 4 inches apart.

Exemplary forehearth arrangements useful in the present invention are shown in FIGs. 6 and 7. Forehearth (322A) is adapted to deliver a molten substance (e.g., molten glass G) from a glass melting furnace to a point of production (i.e., a forming position, discussed below). Molten glass (G) does not contact an upper portion of the forehearth  
30 (322A). Consequently, this portion can be constructed from relatively inexpensive



refractory material (i.e., a super structure refractory material, such as silica, mullite, or other materials that are not required to withstand corrosive effects of molten glass (G)).

A lower portion of forehearth (322A) is below the glass level (L) and thus forms a glass contact surface that comes into contact with the molten glass (G). Consequently, this  
5 portion of forehearth (322A) is constructed of a more costly glass contact material. A ceramic refractory material (i.e., zircon, chromic oxide, or other suitable material) is a suitable glass contact refractory material because it can sustain the corrosive effects of molten glass (G).

Forehearth (322A) may comprise a top or crown (not shown), a bottom (also not  
10 shown), and sidewalls (328A). Forehearth (322A) has an upstream end, generally indicated at (330A), and a downstream end, generally indicated at (332A). An open end (334) may be provided at the downstream end (332A) of forehearth (322A). An end wall (336A) may be provided at the upstream end (330A) of forehearth (322A). One or more glass orifices (338) may be provided in the bottom of forehearth (322A) proximate,  
15 adjacent or close to the end wall (336A). The forehearth of the front end, as introduced above, is that portion of the forehearth (322A) having end wall (336A) and glass orifices (338) in the bottom.

Forehearth burners (344), such as oxygen-fuel burners, are positioned above the glass level (L), shown in FIG. 7. The forehearth burners (344) are oriented in a plane  
20 (e.g., a substantially horizontal plane) perpendicular to the surfaces (340) and at an acute angle relative to the surfaces (340). The forehearth burners (344) are pointed toward the downstream end 332A of forehearth (322A) at an angle between about 5 degrees to about 85 degrees relative to the surfaces (340), as shown in FIG. 6. Forehearth burners (344) may be staggered or alternatively spaced so that opposing forehearth burners (344) in the  
25 opposing sidewalls (328A) are laterally offset or do not laterally align (do not vertically align when viewing FIG. 6) with one another.

The flame temperature of an oxygen-fuel burner is about 4200-5200 ° F. However, the flame is preferably very small. Consequently, the flame does not directly contact the sidewalls (328A). However, heat radiating from the flame is quite substantial. Although  
30 the flame does not directly contact the sidewalls (328A), the sidewalls (328A) are heated sufficiently by convection or heat otherwise radiating from the flame. This radiant heat is

sufficient to properly condition the molten glass (G) and maintain the molten glass G at a desired temperature without compromising the integrity of forehearth (322A) by exposing forehearth (322A) to excessively high temperatures. This holds true even if the burners (344) are spaced about 1 foot to about 5 feet apart from one another.

5           It is to be appreciated that other forehearth burner arrangements are possible and fall within the scope of the invention. For example, another exemplary burner arrangement is illustrated in FIG. 7. The forehearth burners (344) are oriented in a plane (e.g., a substantially vertical plane) perpendicular to the surface (346) and at an acute angle relative to the surface (346). The forehearth burners (344) may be pointed toward  
10 the upstream end 330C of the channel (322C) at an angle between about 5 degrees to about 85 degrees relative to the surface 346, as shown in FIG. 7. Alternatively, the forehearth burners (344) can be pointed toward the downstream end (332C) of the channel (322C) at an angle between about 95 degrees to about 175 degrees relative to the surface (346).

15           It is to be noted that the burners may arranged in the crown (roof) of the forehearth, in the side walls, the end walls, submerged within the batch or molten glass, or in combinations thereof.

#### Bushing assembly

As shown in FIG. 5, a bushing assembly 100 includes a bushing (110) and a  
20 bushing frame 210. The bushing (110) includes a bushing main body (120) with sidewalls (122) and a tip plate (124) extending between the sidewalls (122). The main body (120) is positioned below a bushing block (300) that, in turn, is positioned beneath a forehearth (310). In practicing the method of the present invention, a stream of molten glass is received by the main body (120) from the forehearth (310). The forehearth (310) receives  
25 the molten glass from a melter (10) (shown in FIG. 1). A delivery channel (40) is positioned between the melter (10) and the forehearth (310) to deliver the molten glass batch composition (30) from the melter (10) to the forehearth (310). The forehearth (310) and bushing block (300) may be conventional in construction and may be formed from refractory materials.

30           The tip plate (124) contains a plurality of nozzles (124a) (also referred to as orifices) through which a plurality of streams of molten glass may be discharged. The

streams of molten material may be mechanically drawn from the tip plate (124) to form continuous filaments (125) via a conventional winder device (400) such as a winder or chopper or other means of attenuation. The filaments (125) may be gathered into a single or multiple continuous strands (125a) after having received a protective coating of a sizing composition from a sizing applicator (410). The continuous filaments (125a) may be wound onto a rotating collet (402) of the winder device (400) to form a package (125b). The continuous filaments (125) may also be processed into other desired composite glass materials including, without limitation, wet use chopped strand fibers, dry use chopped strand fibers, continuous filament mats, chopped strand mats, wet formed mats or air laid mats.

High strength articles of the present invention use the formed fibers described above as glass fiber reinforcement within a polymer matrix material. Typical matrix materials include epoxies, phenolic resins, vinylesters, and polyesters. The articles may be formed by any suitable manufacturing technique including compression molding, laminating, spray up, hand laying, prefabricated lay-up (prepreg), compression molding, vacuum bag molding, pressure bag molding, press molding, transfer molding, vacuum assisted resin transfer molding, pultrusion molding, filament winding, casting, autoclave molding, centrifugal casting resin transfer and continuous casting.

Having generally described this invention, a further understanding can be obtained by reference to certain specific examples illustrated below which are provided for purposes of illustration only and are not intended to be all inclusive or limiting unless otherwise specified.

#### EXAMPLES

The glasses in the examples listed in Tables IIA - IIC were melted in platinum crucibles or in a continuous platinum-lined melter for determining the mechanical and physical properties of the glass and fibers produced there from. The units of measurement for the physical properties are: Viscosity ( $^{\circ}$  F), Liquidus temperature ( $^{\circ}$  F) and  $\Delta T$  ( $^{\circ}$  F). In some examples the glasses were fiberized and Strength (KPsi), Density (g/cc), and Modulus (MPsi) were measured.

The fiberizing temperature was measured using a rotating spindle viscometer. The fiberizing viscosity is defined as 1000 Poise. The liquidus was measured by placing a platinum container filled with glass in a thermal gradient furnace for 16 hours. The greatest temperature at which crystals were present was considered the liquidus temperature. The modulus was measured using the sonic technique on a single fiber of glass. The tensile strength was measured on a pristine single fiber.

Table II-A

Glass	Ex. 1	Ex. 2	Ex. 3	Ex. 4	Ex. 5	Ex. 6
SiO <sub>2</sub>	67.2	69	67	70	70	65
Al <sub>2</sub> O <sub>3</sub>	20	22	22	17	17	21
MgO	9.8	9	11	11	10	11
Li <sub>2</sub> O	3	0	0	2	3	3
Measured Viscosity(° F)	2531 1388	2761 1516	2648 1453	2557 1403	2558 1403	2461 1349
1 <sup>st</sup> Measured Liquidus (° F)	2313 1267	2619 1437	2597 1425	2332 1278	2302 1261	2296 1258
2 <sup>nd</sup> Measured Liquidus (° F)	2302 1261	2620 1438	2614 1434	2346 1286	2308 1264	2318 1270
ΔT (° F)	218 121.1	142 78.89	51 28.33	225 125	256 142.2	165 91.67
Measured Density (g/cc)	2.459	2.452	2.481	2.450	2.441	2.482

Table II-B

Glass	Ex. 7	Ex. 8	Ex. 9	Ex. 10	Ex. 11	Ex. 12
SiO <sub>2</sub>	70	69	70	65	66	65
Al <sub>2</sub> O <sub>3</sub>	18	17	21	22	22	22
MgO	9	11	9	11	9	10
Li <sub>2</sub> O	3	3	0	2	3	3
Measured Viscosity ° F (°C)	2544 (1396)	2496 (1369)	2752 (1511)	2525 (1385)	2523 (1384)	2486 (1363)
1 <sup>st</sup> Measured Liquidus ° F (°C)	2311 (1266)	2234 (1223)	2597 (1425)	2468 (1353)	2391 (1311)	2361 (1294)
2 <sup>nd</sup> Measured Liquidus ° F (°C)	2324 (1273)	2343 (1284)	2603 (1428)	2462 (1350)	2394 (1312)	2382 (1306)
ΔT ° F (°C)	233 (129.44)	262 (145.56)	155 (86.11)	57 (31.67)	132 (73.33)	125 (69.44)
Measured Density (g/cc)	2.434	2.455	2.443	2.486	2.460	2.474

Table II-C

Glass	Ex. 13	Ex. 14	Ex. 15	Ex. 16	Ex. 17	Ex. 18
SiO <sub>2</sub>	70	67.32	67.57	68.27	68.02	67.76
Al <sub>2</sub> O <sub>3</sub>	19	20.49	20.49	20.10	20.10	20.10
MgO	11	10.00	10.00	9.69	9.69	9.69
Li <sub>2</sub> O	0	2.00	1.75	1.75	2.00	2.25
Measured Viscosity ° F (°C)	2679 (1471)	2563 (1406)	2584 (1418)	2598 (1426)	2578 (1414)	2547 (1397)
1 <sup>st</sup> Measured Liquidus ° F (°C)	2596 (1424)	2456 (1347)	2486 (1363)	2446 (1341)	2431 (1333)	2399 (1315)
2 <sup>nd</sup> Measured Liquidus ° F (°C)	2582 (1417)	2447 (1342)	2469 (1354)	2469 (1354)	2437 (1354)	2406 (1319)
ΔT ° F (°C)	83 (46.11)	111.5 (61.94)	106.5 (59.17)	140.5 (78.06)	144 (80)	144.5 (80.28)
Measured Density (g/cc)	2.453		2.461		2.452	

The compositions useful in the present invention may also include chain modifiers such as Na<sub>2</sub>O, CaO and B<sub>2</sub>O<sub>3</sub>. Such compositions are shown in Table II-D (below).

Table II-D

Glass	Ex. 19	Ex. 21	Ex. 22	Ex. 22	Ex. 23	Ex. 24
SiO <sub>2</sub>	75	66	65	65	66	74
Al <sub>2</sub> O <sub>3</sub>	15	20	20	24	19	15
MgO	8	9	8	8	9	8
Li <sub>2</sub> O	1	1	2	0	0	0
Na <sub>2</sub> O	1	2	1	1	2	3
CaO		2	4			
B <sub>2</sub> O <sub>3</sub>				2	4	
Measured Viscosity ° F (°C)	2765 (1518)	2607 (1431)	2469 (1354)	2669 (1465)		2809 (1543)
1 <sup>st</sup> Measured Liquidus ° F (°C)	2422 (1328)	2729 (1498)		2614 (1434)	2630 (1443)	2680 (1471)
ΔT ° F (°C)	343 (190.56)	-122 (-67.78)		55 (30.56)		129 (71.67)

5

The fibers produced by the present invention have superior modulus and strength characteristics. The fibers of Example 1 have a Measured Modulus of 12.71 MPsi and a Measured Strength of 688 KPsi. The fibers of Example 3 have a Measured Modulus of 12.96 MPsi and a Measured Strength of 737 KPsi. The fibers of Example 17 have a Measured Modulus of 12.75 MPsi and a Measured Strength of 734 KPsi.

As is understood in the art, the above exemplary inventive compositions do not always total 100% of the listed components due to statistical conventions (such as, rounding and averaging) and the fact that some compositions may include impurities that are not listed. Of course, the actual amounts of all components, including any impurities, in a composition always total 100%. Furthermore, it should be understood that where small quantities of components are specified in the compositions, for example, quantities on the order of about 0.05 weight percent or less, those components may be present in the form of trace impurities present in the raw materials, rather than intentionally added.

15

Additionally, components may be added to the batch composition, for example, to facilitate processing, that are later eliminated, thereby forming a glass composition that is essentially free of such components. Thus, for instance, minute quantities of components such as fluorine and sulfate may be present as trace impurities in the raw materials  
5 providing the silica, lithia, alumina, and magnesia components in commercial practice of the invention or they may be processing aids that are essentially lost during manufacture.

As is apparent from the above examples, certain glass fiber compositions useful in the invention have advantageous properties, such as low fiberizing temperatures and wide differences between the liquidus temperatures and the fiberizing temperatures (high  $\Delta T$   
10 values). Other advantages and obvious modifications of the invention will be apparent to the artisan from the above description and further through practice of the invention.

In certain embodiments the high-performance glass produced by the present invention melts and refines at relatively low temperatures, has a workable viscosity over a wide range of relatively low temperatures, and a low liquidus temperature range.

15 In other embodiments the high-performance glass produced by the present invention melts and refines at relatively high temperatures, and has a workable viscosity over a relatively small temperature range.

The invention of this application has been described above both generically and with regard to specific embodiments. Although the invention has been set forth in what is  
20 believed to be the preferred embodiments, a wide variety of alternatives known to those of skill in the art can be selected within the generic disclosure. Other advantages and obvious modifications of the invention will be apparent to the artisan from the above description and further through practice of the invention. The invention is not otherwise limited, except for the recitation of the claims set forth below.

CLAIMS

We Claim:

1. A method of forming high strength glass fibers in a continuous system having a furnace (10), a forehearth (12), and a bushing (110), the method comprising:
  - 5 providing a glass melting furnace for receiving glass batch (30) and discharging molten glass, and lining at least a portion of the furnace with a material substantially free of noble metal materials to form a furnace glass contact surface;
    - supplying glass batch to the furnace, the glass batch being capable of forming a fiberizable molten glass having a fiberizing  $\Delta T$  greater than 45 °F (25 °C) and for
    - 10 producing glass fibers having a composition comprising:
      - about 50 - about 75 weight percent SiO<sub>2</sub>;
      - about 15 - about 30 weight percent Al<sub>2</sub>O<sub>3</sub>;
      - about 5 - about 20 weight percent MgO;
      - about 0 - about 10 weight percent CaO;
      - 15 about 0 - about 5 weight percent R<sub>2</sub>O, where R<sub>2</sub>O equals the sum of Li<sub>2</sub>O, Na<sub>2</sub>O and K<sub>2</sub>O; and trace impurities, wherein each impurity is present at about 0.05 weight percent or less;
    - melting the glass batch in the furnace by providing heat from a furnace heat source and forming a pool of molten glass in contact with the furnace glass contact surface;
    - 20 providing a forehearth for transporting molten glass from the furnace to the bushing, and lining at least a portion of the forehearth with a material substantially free of noble metal materials to form a forehearth glass contact surface;
      - transporting the molten glass in the forehearth while providing heat from a forehearth heat source and flowing the molten glass through the forehearth along a
      - 25 substantially horizontal flow path formed by the forehearth glass contact surface;
    - discharging the molten glass from the forehearth into the bushing at a temperature of about 2400 °F (1316 °C) to about 2900 °F (1593 °C) and a predetermined viscosity; and
    - forming the molten glass into continuous fibers.



2. The method of claim 1, wherein the transporting step includes flowing the molten glass through the forehearth (12) at a depth of less than about 8 inches.
3. The method of claim 2, wherein the transporting step includes flowing the molten glass through the forehearth (12) at a depth of less than about 3.5 inches.
- 5 4. The method claim 1, wherein the step of lining the furnace (10) includes lining at least a portion of the furnace with an oxide-based furnace refractory material.
5. The method of claim 4, wherein the step of lining the furnace (10) to form a furnace glass contact surface includes lining at least a portion of the furnace with a material selected from the group consisting of chromic oxide materials and zircon.
- 10 6. The method of claim 1, wherein the step of lining the furnace (10) includes lining at least a portion of the furnace with externally cooled walls.
7. The method of claim 1, wherein the step of lining the forehearth (12) to form a forehearth glass contact surface includes lining at least a portion of the forehearth with an oxide-based forehearth refractory material.
- 15 8. The method of claim 7, wherein the step of lining the forehearth (12) includes lining the forehearth with a material selected from the group consisting of chromic oxide materials and zircon.
9. The method of claim 1, wherein the step of providing heat from a furnace (10) heat source further comprises installing one or more oxy-fuel burners(34) in a roof (22), a  
20 sidewall (328A), an endwall or a bottom of the furnace, or combinations thereof.
10. The method of claim 1, wherein the step of providing heat from a forehearth (12) heat source further comprises installing one or more oxy-fuel burners (34) in a roof (22), a sidewall (328A), or an endwall of the forehearth, or combinations thereof.
11. The method of claim 1, wherein the step of providing heat from a forehearth (12)  
25 heat source further comprises installing one or more air-fuel burners (34) in a roof (22), a sidewall (328A), or an endwall of the furnace (10), or combinations thereof, at a spacing sufficient to prevent devitrification of the molten glass in the forehearth.

12. The method of claim 11, further comprising the step of installing air-fuel burners (34) at a spacing of about 4 inches.
13. The method of claim 1, further comprising the step of installing one or more bubblers (24), electric boost electrodes, and combinations thereof in the glass melting  
5 furnace (10).
14. The method of claim 1, further comprising the step of installing one or more bubblers (24), electric boost electrodes, and combinations thereof in the forehearth (12).
15. The method of claim 1, wherein the predetermined viscosity is about 1000 poise.
16. The method of claim 1, wherein the predetermined viscosity is about 316 poise.
- 10 17. The method of claim 1, wherein the glass fibers produced have a density of 2.434 – 2.520 g/cc.
18. The method of claim 1, wherein the glass fibers produced have a measured modulus greater than 12.7 MPsi.
19. The method of claim 1, wherein the glass fibers produced have a measured  
15 strength greater than 680 KPsi.
20. The method of claim 1, wherein the glass fibers produced have a density of 2.434 – 2.520 g/cc and a measured modulus greater than 12.7 MPsi.
21. The method of claim 1, wherein the glass fibers produced have a density of 2.434 – 2.486 g/cc and a measured strength of 688 – 737 KPsi.
- 20 22. A process for producing glass fibers from raw glass batch in a refractory-lined glass melter, the process comprising the steps of:  
charging raw glass batch to the melting zone of a refractory-lined glass melter, the glass batch comprising:  
64-75 weight percent SiO<sub>2</sub>;  
25 16-26 weight percent Al<sub>2</sub>O<sub>3</sub>;  
8-12 weight percent MgO; and

- 0-3 weight percent  $R_2O$ , where  $R_2O$  equals the sum of  $Li_2O$ ,  $Na_2O$  and  $K_2O$ ;  
 heating the glass batch to a forming temperature in excess of the liquidus  
 temperature of a resulting glass to form a fiberizable molten glass; and  
 fiberizing said molten glass.
- 5 23. A process for producing glass fibers from raw glass batch in a refractory-lined  
 glass melter, the process comprising the steps of:  
 charging raw glass batch to the melting zone of a refractory-lined glass melter, the  
 glass batch comprising:
- 64-75 weight percent  $SiO_2$ ;  
 10 16-24 weight percent  $Al_2O_3$ ;  
 8-12 weight percent  $MgO$ ; and  
 0.25-3 weight percent  $R_2O$ , where  $R_2O$  equals the sum of  $Li_2O$ ,  $Na_2O$  and  $K_2O$ ;  
 heating the glass batch to a forming temperature in excess of the liquidus  
 temperature of a resulting glass to form a fiberizable molten glass; and  
 15 fiberizing said molten glass.
24. The process of claim 23, wherein the glass batch comprises:  
 about 68 weight percent  $SiO_2$ ;  
 about 20 weight percent  $Al_2O_3$ ;  
 about 10 weight percent  $MgO$ ; and  
 20 about 2 weight  $Li_2O$ .
25. The process of claim 23, wherein the glass batch comprises:  
 about 68 weight percent  $SiO_2$ ;  
 about 20 weight percent  $Al_2O_3$ ;  
 about 9.7 weight percent  $MgO$ ; and  
 25 about 2 weight  $Li_2O$ .

26. The process of claim 23, wherein the glass batch comprises:  
less than 5 weight percent total of compounds selected from the group consisting of CaO, P<sub>2</sub>O<sub>5</sub>, ZnO, ZrO<sub>2</sub>, SrO, BaO, SO<sub>3</sub>, Fluorine, B<sub>2</sub>O<sub>3</sub>, TiO<sub>2</sub>, Fe<sub>2</sub>O<sub>3</sub>, CeO<sub>2</sub> and BeO<sub>2</sub>.
27. The process of claim 23, wherein glass produced from said batch has a fiberizing  
5 temperature of less than 2650° F (1454 °C), and a ΔT of at least 80° F (44.44 °C).
28. The process of claim 23 wherein glass produced from said batch has a ΔT of at  
least 120° F (66.67 °C).
29. The process of claim 23, wherein the glass melter is lined with an oxide-based  
refractory material.
- 10 30. The process of claim 23, wherein the glass melter is lined with a refractory  
material selected from the group consisting of alumina, silica, chromic oxide, alumina-  
silica, zircon, zirconia-alumina-silica and combinations thereof.
31. The process of claim 23, wherein glass produced from the batch is fiberized at a  
forming temperature of less than 2600° F (1427 °C).
- 15 32. The process of claim 23, wherein glass produced from the batch has a ΔT of at  
least 140° F (77.78 °C).
33. A process for producing glass from raw glass-forming material in a refractory-  
lined glass melter, the glass melter having a roof (22), a bottom and side walls (328A),  
defining an elongated channel (322C) having a melting zone and a downstream refining  
20 zone (28), the process comprising the steps of:  
charging raw glass batch (30) to the melting zone of the refractory-lined glass  
melter, the glass batch comprising:  
64-75 weight percent SiO<sub>2</sub>;  
16-24 weight percent Al<sub>2</sub>O<sub>3</sub>;  
25 8-12 weight percent MgO; and  
0.25-3 weight percent R<sub>2</sub>O, where R<sub>2</sub>O equals the sum of Li<sub>2</sub>O, Na<sub>2</sub>O and K<sub>2</sub>O;  
providing at least one burner (34) within the roof (22) of the glass melter; and

melting the glass batch to form a fiberizable molten glass.

34. The process of claim 32, wherein the glass produced from the batch (30) is fiberized at a forming temperature of less than 2650° F (1454 °C).

35. A process for producing glass from raw glass-forming material in a refractory-lined glass melter, the glass melter having a roof (22), a bottom and side walls (328A), defining an elongated channel (322C) having a melting zone and a downstream refining zone (16), the process comprising the steps of:

charging raw glass batch (30) to the melting zone of the refractory-lined glass melter, the glass batch comprising:

10 68-69 weight percent SiO<sub>2</sub>;

20-22 weight percent Al<sub>2</sub>O<sub>3</sub>;

9-10 weight percent MgO; and

1-3 weight percent Li<sub>2</sub>O.

providing at least one burner (34) within the roof (22) of the glass melter (10); and

15 melting the glass batch to form a fiberizable molten glass.

36. A glass fiber produced from raw glass batch in a refractory-lined glass melter (10) in a process comprising the steps of:

charging raw glass batch (30) to the melting zone of a refractory-lined glass melter, the glass batch comprising:

20 64-75 weight percent SiO<sub>2</sub>;

16-24 weight percent Al<sub>2</sub>O<sub>3</sub>;

8-12 weight percent MgO; and

0.25-3 weight percent R<sub>2</sub>O, where R<sub>2</sub>O equals the sum of Li<sub>2</sub>O, Na<sub>2</sub>O and K<sub>2</sub>O;

25 heating the glass batch to a forming temperature in excess of the liquidus temperature of a resulting glass to form a fiberizable molten glass; and

fiberizing said molten glass.

37. A high strength article, comprising:

a matrix material; and

a plurality of glass fibers formed from a glass batch composition comprising:

64-75 weight percent  $\text{SiO}_2$ ;

16-24 weight percent  $\text{Al}_2\text{O}_3$ ;

5 8-12 weight percent  $\text{MgO}$ ; and

0.25-3 weight percent  $\text{R}_2\text{O}$ , where  $\text{R}_2\text{O}$  equals the sum of  $\text{Li}_2\text{O}$ ,  $\text{Na}_2\text{O}$  and  $\text{K}_2\text{O}$ .

38. The high strength article of claim 37 wherein the glass batch composition comprises:

10 about 68 weight percent  $\text{SiO}_2$ ;

about 20 weight percent  $\text{Al}_2\text{O}_3$ ;

about 10 weight percent  $\text{MgO}$ ; and

about 2 weight  $\text{Li}_2\text{O}$ .

39. The high strength article of claim 38, wherein the glass batch composition  
15 comprises:

about 68 weight percent  $\text{SiO}_2$ ;

about 20 weight percent  $\text{Al}_2\text{O}_3$ ;

about 9.7 weight percent  $\text{MgO}$ ; and

about 2 weight  $\text{Li}_2\text{O}$ .

20 40. The high strength article of claim 37, wherein the glass fibers have a density of 2.434 – 2.486 g/cc.

41. The high strength article of claim 37, wherein the glass fibers have a measured modulus of 12.71 – 12.96 MPsi.

25 42. The high strength article of claim 37, wherein the glass fibers have a measured strength of 688 – 737 KPsi.

43. The high strength article of claim 37, wherein the glass fibers have a density of 2.434 – 2.486 g/cc and a measured modulus of 12.71 – 12.96 MPsi.
44. The high strength article of claim 37, wherein the glass fibers have a density of 2.434 – 2.486 g/cc and a measured strength of 688 – 737 KPsi.
- 5 45. The high strength article of claim 37, wherein the matrix is selected from the group consisting of polyester resin, vinylester-phenolic resin, vinylester resin and epoxy resin, bismaleimide, poly- amide, vinyl ester phenolic, ethylene-acrylate or methacrylate copolymers, crosslinked ethylene-methyl acrylate, methyl methacrylate copolymer and ionomer, polycarbonate, polyurethane, nylon or aramid, modified epoxies.
- 10 46. The high strength article of claim 37, wherein the matrix material is a phenolic matrix material.
47. A process for manufacturing a high strength composite article comprising the steps of:
- forming fibers from a glass batch composition comprising.
- 15 64-75 weight percent SiO<sub>2</sub>;  
16-24 weight percent Al<sub>2</sub>O<sub>3</sub>;  
8-12 weight percent MgO; and  
0.25-3 weight percent R<sub>2</sub>O, where R<sub>2</sub>O equals the sum of Li<sub>2</sub>O, Na<sub>2</sub>O and K<sub>2</sub>O;
- 20 combining the fibers with a matrix material;  
shaping an article; and  
curing the matrix material.
48. The process of claim 47, including the step of:
- forming an intermediate glass structure selected from the group consisting of wet  
25 used chopped strand, dry use chopped strand, continuous filament mat, chopped strand mat, wet formed mat and air laid mat.

49. The process of claim 47, wherein the shaping step is selected from the group consisting of compression molding, laminating, spray up, hand laying, prefabricated lay-up, vacuum bag molding, pressure bag molding, press molding, transfer molding, vacuum assisted resin transfer molding, pultrusion molding, filament winding, casting, autoclave  
5 molding, centrifugal casting resin transfer and continuous casting.
50. The process of claim 47, wherein the glass batch composition comprises:  
about 68 weight percent SiO<sub>2</sub>;  
about 20 weight percent Al<sub>2</sub>O<sub>3</sub>;  
about 10 weight percent MgO; and  
10 about 2 weight Li<sub>2</sub>O.
51. The process of claim 47, wherein the matrix is selected from the group consisting of polyester resin, vinylester –phenolic resin, vinylester resin and epoxy resin, bismaleimide, poly- amide, vinyl ester phenolic, ethylene-acrylate or methacrylate copolymers, crosslinked ethylene-methyl acrylate, methyl methacrylate copolymer and  
15 ionomer, polycarbonate, polyurethane, nylon or aramid, modified epoxies.



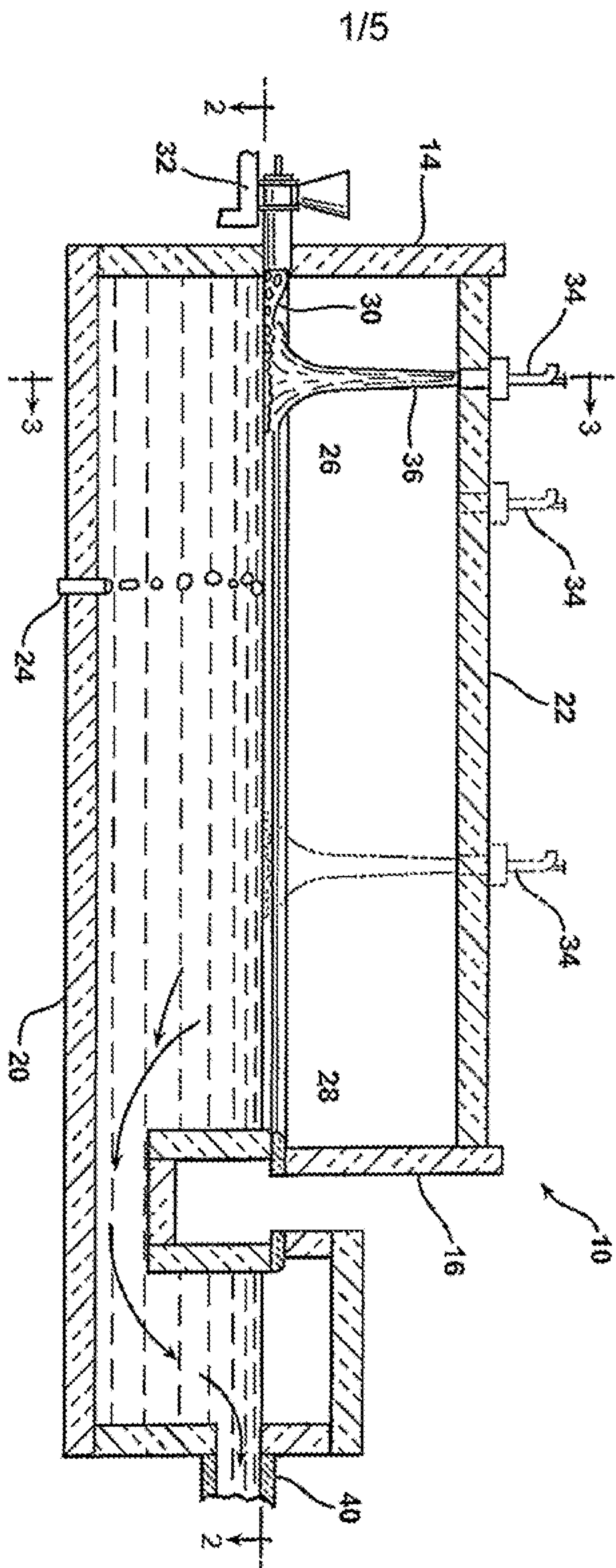

2/5

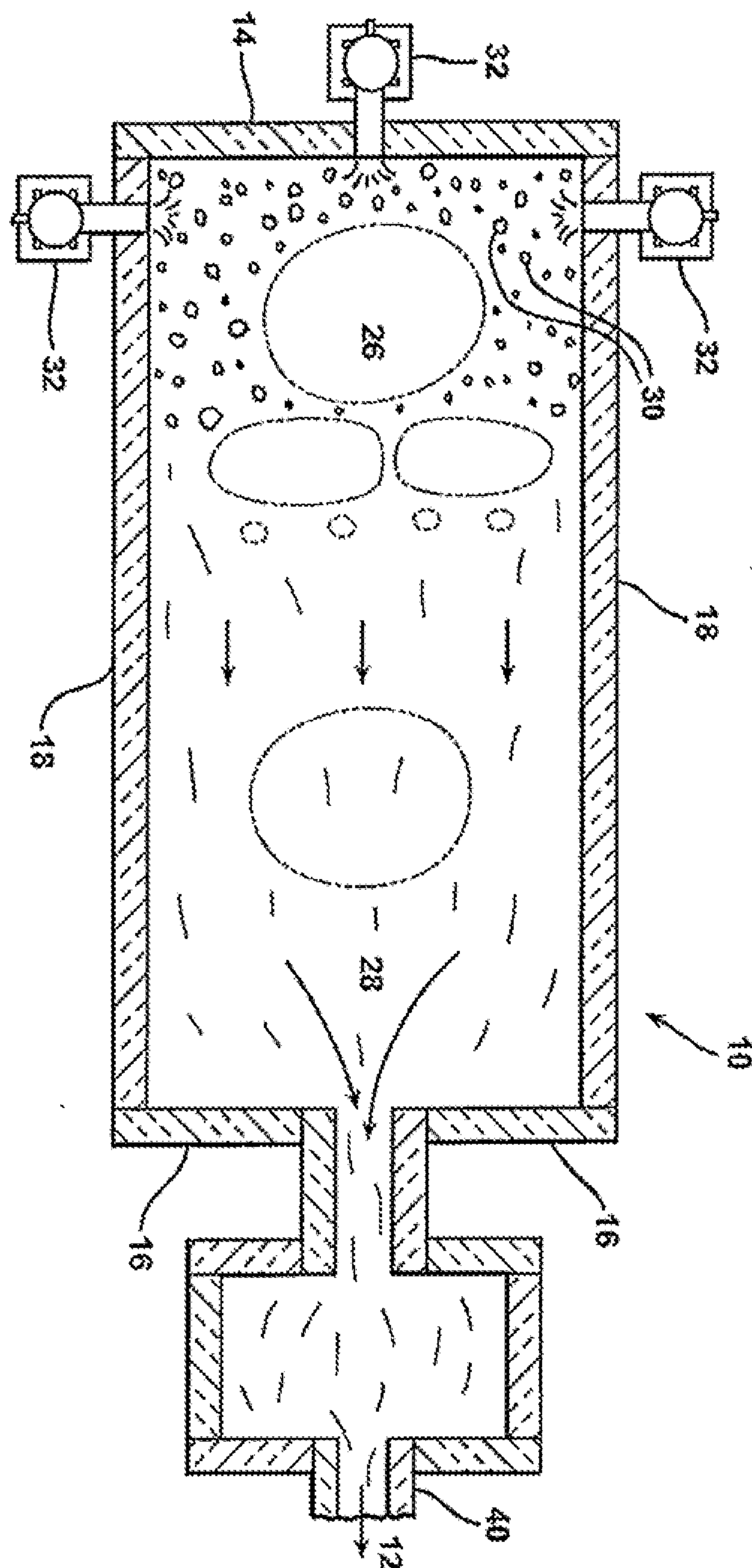

FIG. 2

3/5

FIG. 3

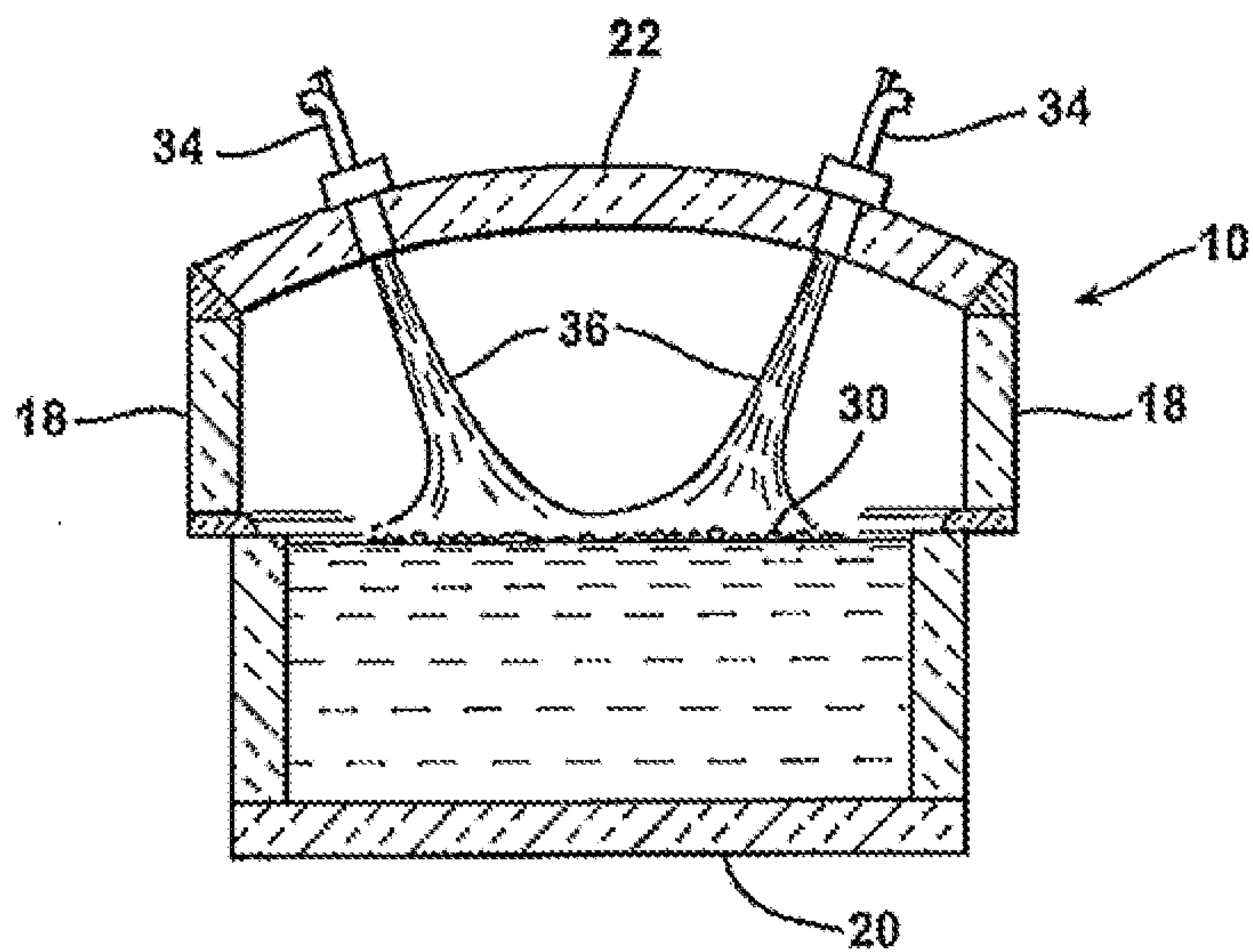
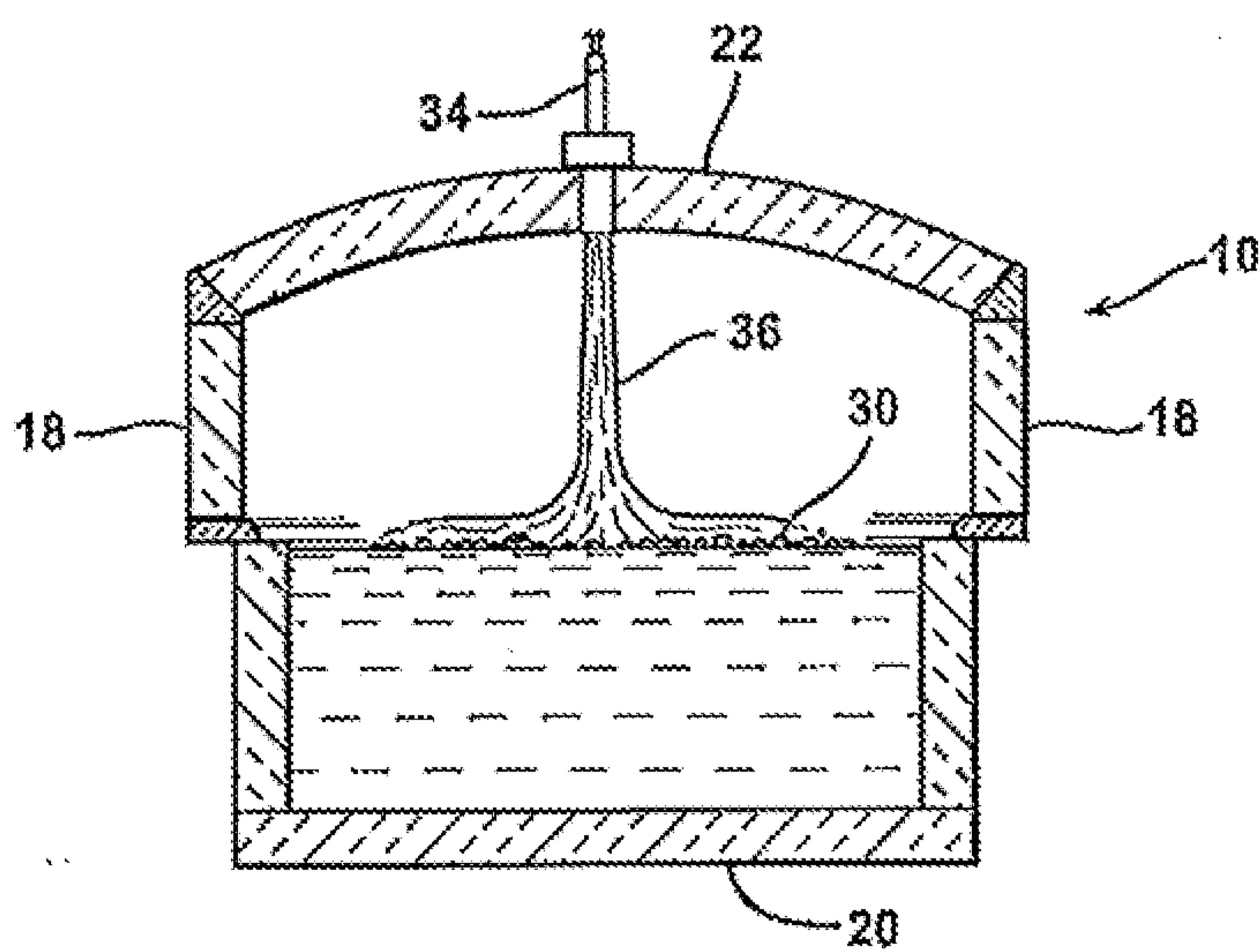
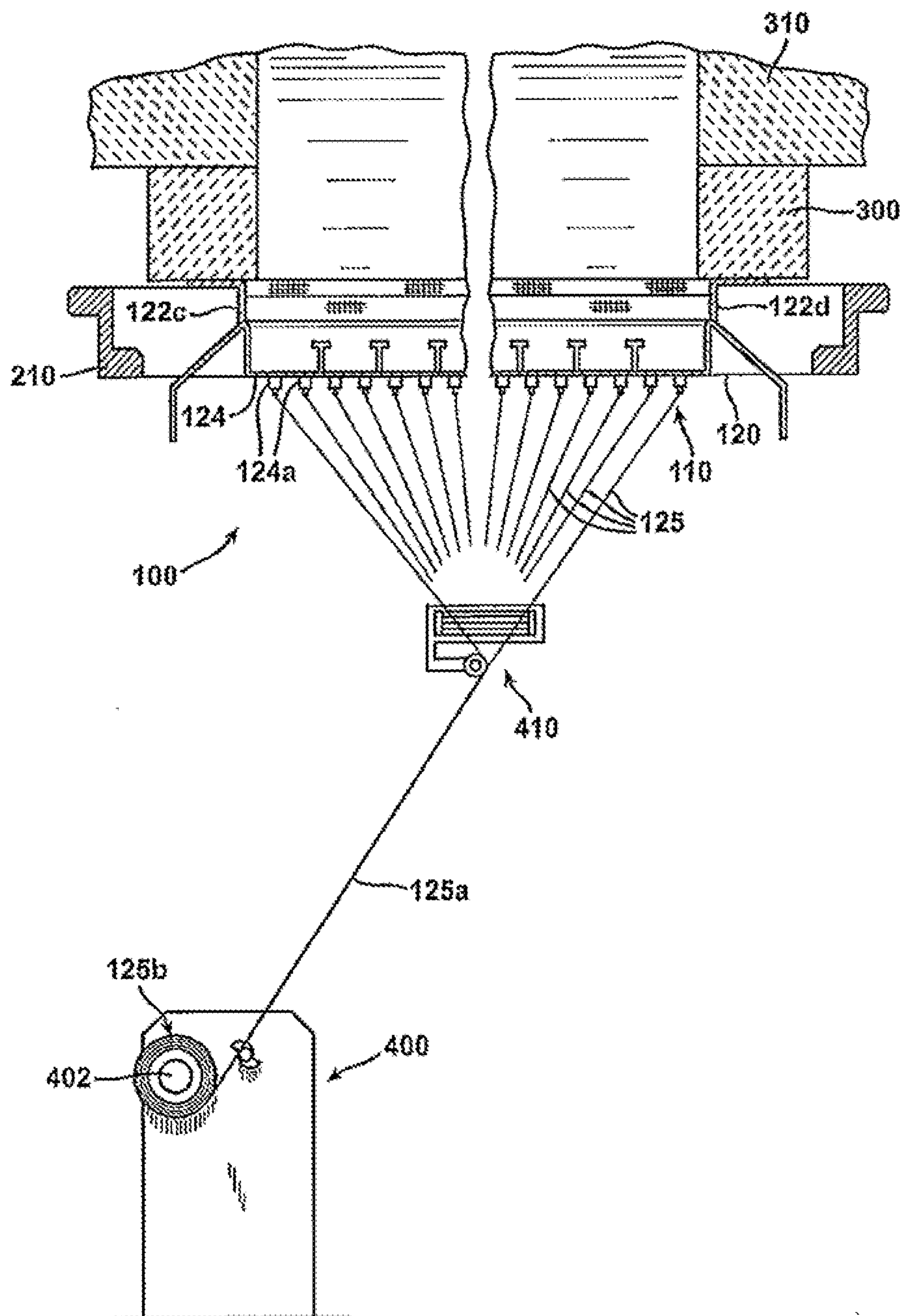

FIG. 4



4/5

FIG. 5



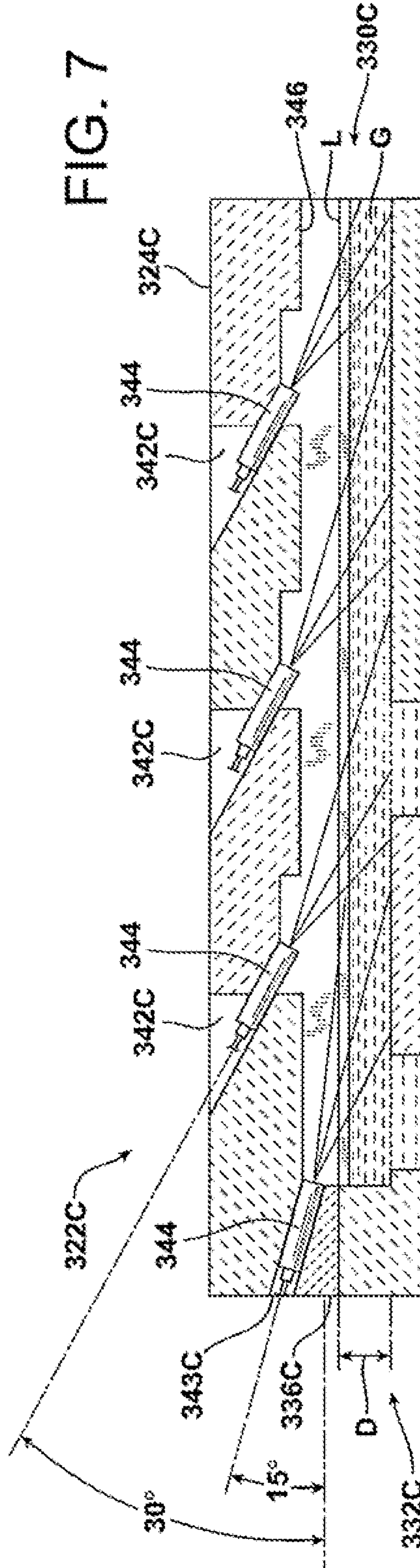
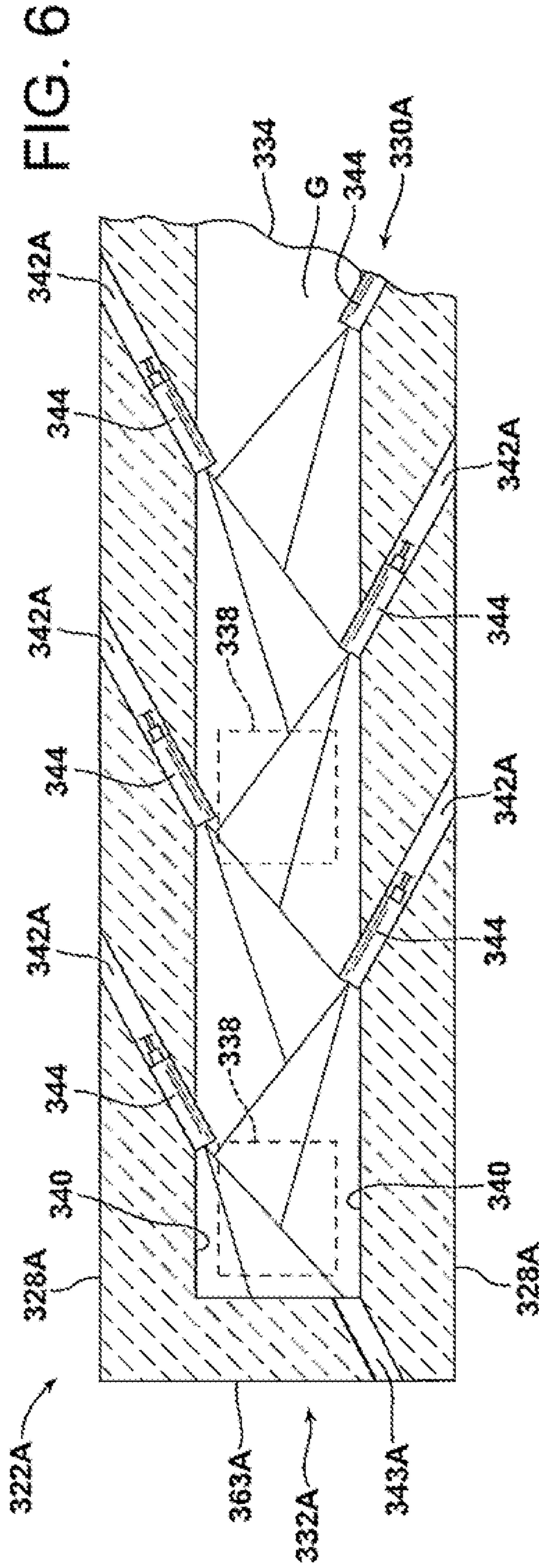

FIG. 1

