



(22) Date de dépôt/Filing Date: 2000/04/20

(41) Mise à la disp. pub./Open to Public Insp.: 2001/10/20

(45) Date de délivrance/Issue Date: 2006/06/27

(51) Cl.Int./Int.Cl. *B08B 9/023* (2006.01),
B08B 9/02 (2006.01), *C02F 1/32* (2006.01),
B21C 43/00 (2006.01), *B08B 1/00* (2006.01)

(72) Inventeurs/Inventors:
WANG, DEMAO, CA;
SOTIRAKOS, BILL, CA

(73) Propriétaire/Owner:
PHOTOSCIENCE JAPAN CORPORATION, JP

(74) Agent: SIM & MCBURNEY

(54) Titre : GRATTOIR DE TUBES

(54) Title: TUBE SCRAPER

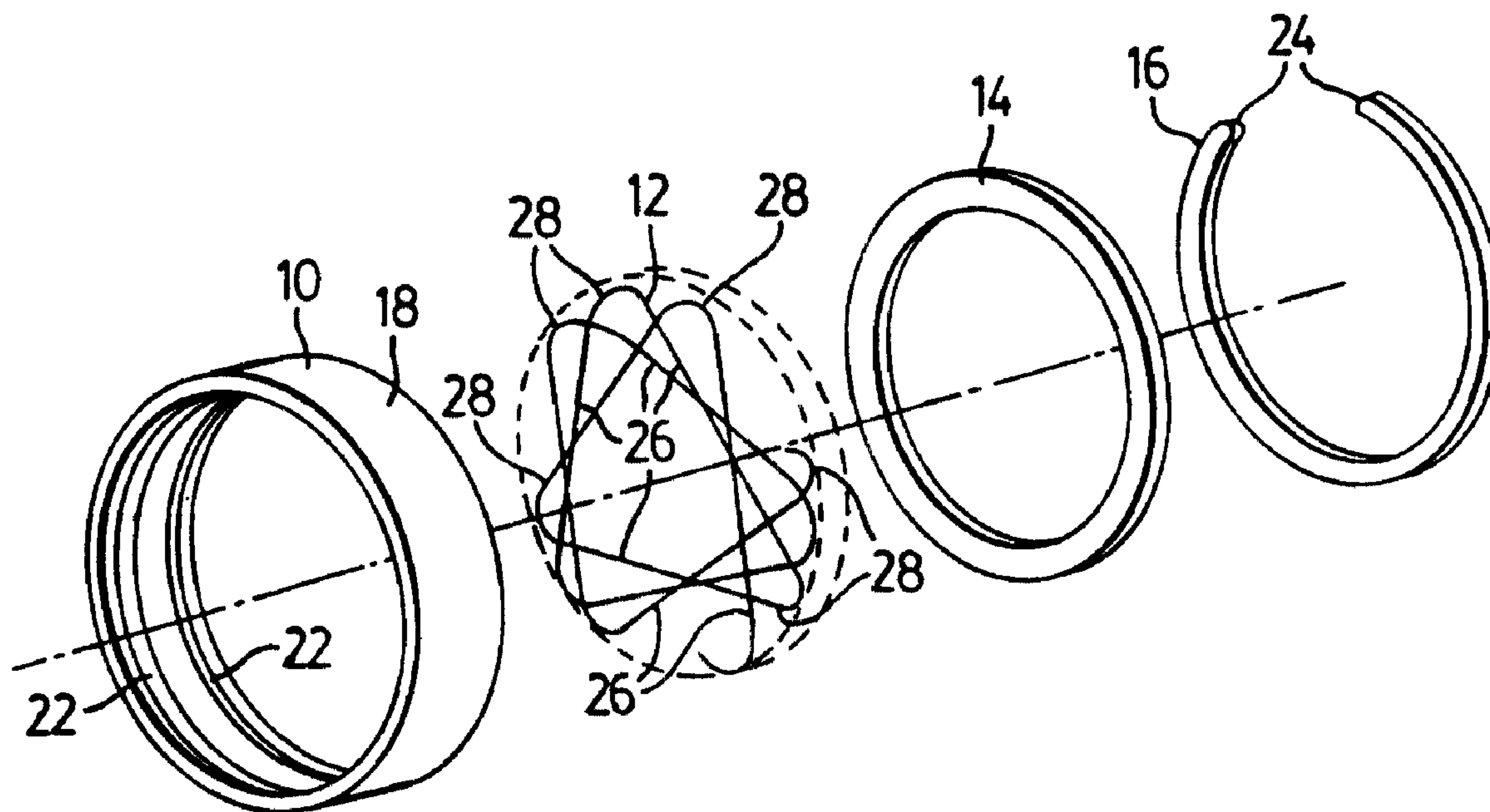

(57) Abrégé/Abstract:

A scraper for removing deposits from the exterior of a tubular member includes elements defining an outer jacket which has an inwardly open circumferential recess and two aligned axial openings, and a scraper element in the form of an elongate resilient wire bent to define a series of integral, concatenated, resilient segments, each pair of adjacent segments being connected through a bend or geniculation. All geniculations are received within the recess, and each segment of wire extends generally along a chord of the aligned axial openings. The positions of the chords are distributed around the circumference of the axial openings such that, in order for the tubular member to be accommodated through the aligned openings, the various segments must be deformed outwardly, whereby the resilience of the thus deformed segment urges it inwardly against the tubular member, and causes it to clean the tubular member as the scraper moves axially.

ABSTRACT OF THE DISCLOSURE

A scraper for removing deposits from the exterior of a tubular member includes elements defining an outer jacket which has an inwardly open
5 circumferential recess and two aligned axial openings, and a scraper element in the form of an elongate resilient wire bent to define a series of integral, concatenated, resilient segments, each pair of adjacent segments being connected through a bend or geniculation. All geniculations are received within the recess, and each segment of wire extends generally along a chord of the aligned axial openings. The positions
10 of the chords are distributed around the circumference of the axial openings such that, in order for the tubular member to be accommodated through the aligned openings, the various segments must be deformed outwardly, whereby the resilience of the thus deformed segment urges it inwardly against the tubular member, and causes it to clean the tubular member as the scraper moves axially.

TUBE SCRAPER

This invention relates generally to a method and apparatus for maintaining the external surface of a tubular member free of scale, deposits, and the like. This invention is particularly suited to the scraping and cleaning of protective quartz tubes used in the ultra-violet sterilisation and/or disinfection of water and other liquids, but is not limited thereto.

Prior Art

10

Exemplary of the prior developments in this area is U.S. patent 5,266,280, issued November 30, 1993 to Hallett. In Hallett's system a cylindrical UV-transparent sheath is utilized to isolate a UV lamp from the interior space of a reactor vessel, in which the sheath is sealed in such a way as to isolate the UV lamp from the fluid. Hallett provides a brush device for brushing the exterior surface of the sheath to remove materials deposited from the fluid. The brush has at least two brushes with bristles extending radially inwardly towards the sheath as the brushes encompass the sheath. The brushes are coupled together in spaced-apart manner on the sheath with a device for reciprocating the brushes along the exterior of the sheath, preferably on a periodic basis.

20

Another prior patent of interest is U.S. patent 3,462,597, issued on August 19, 1969 to Albert Young. This patent discloses a UV lamp system for water purification. The development includes a wiper system for the protective sheath surrounding the UV lamp, the wiper system comprising wiper rings made from Teflon™ or like material not affected by UV radiation. The rings are spaced apart from one another and are preferably split so that they can be elastically or resiliently held on the outside of the protective tube by a spring. The wiping ring is connected to a ring holder which is engaged by a rod that extends through an end of the reactor. The ring holder is then reciprocated to provide a wiping action along the

30

protective tube to remove physical or biological materials that have deposited on the outside of the tube.

Another patent of interest is U.S. 3,562,520, issued on February, 1971 to
5 Hippen. This patent involves the use of a wiper system to routinely clean a protective quartz tube surrounding a UV lamp. The wiper system includes a number of ring-like wiper elements surrounding and in wiping contact with the external surface of the protective tube. The wiper assembly is urged along the tube by a coil spring. When water to be treated flows through the reactor, the wiper
10 returns to the other end of the tube to effect a wiping of the area of the tube between the inlet and outlet. This is said to ensure that the protective tube is free of deposits during each start-up of the water purifying device.

In U.S. patent 3,904,363, issued on September 9, 1975 to David Free, the
15 wiper system is activated by water flow (as also happens in U.S. '520). However, for extended continuous water flow, the protective tube would not be cleaned. Water flow moves the wiper system to one end of the tube and keeps it there. When the water shuts off, the wipers descend to the base of the reactor under the influence of gravity. The wiper system includes a flexible semi-rigid plastic or flexible metal
20 membrane. The membrane may be a brush-like textured membrane of composite or plastic material. However, the membrane is very thin and is likely to be inadequate to remove stubborn deposits on the protective sheath. Also, the plastic version of the wiper would be subject to deterioration under a high intensity UV radiation from high powered lamps.

25

The inability of the device of US '363 to operate properly with a continuous flow of water is also a shortcoming of US '520. Thus, an extended water flow through the device would allow the gradual build-up of deposits on the protective tube, thus reducing the degree of UV transmittance and thereby the effectiveness of
30 the radiation in treating bacteria.

The second-mentioned prior patent, US 3,462,597 provides a system that is inadequate due to dimensional variations in the protective tube which is normally made of quartz. Further the wiper system, utilizing wiper rings made of Teflon™ or similar material, would not clean the quartz surface due to a) the lack of a sharp, hard surface (such as a razor) and b) the slipperiness of Teflon.

Additional prior patents of some relevance are the following:

- U.S. 4,482,809, issued on November 13, 1984 to Maarschalkerweerd;
- U.S. 4,872,980, issued on October 10, 1989 to Maarschalkerweerd ;
- U.S. 5,006,244, issued on April 9, 1991 to Maarschalkerweerd ;
- U.S. 5,418,370, issued on May 23, 1995 to Maarschalkerweerd .

In the devices described in U.S. '809, '980 and '244, the sleeve surrounding the UV lamps becomes periodically fouled with foreign materials, and then require manual cleaning to remove such materials.

U.S. patent '370 overcomes the basic disadvantage just mentioned by providing a cleaning apparatus which incorporates a cleaning sleeve engaging a portion of the exterior of the radiation source assembly and moveable between a retracted position and an extended position. The cleaning sleeve includes the chamber in contact with part of the radiation source, which chamber is supplied with a cleaning solution suitable to remove undesired materials. While the U.S. patent '370 represents an advance in the art, it tends to be relatively complicated and expensive.

GENERAL DESCRIPTION OF THIS INVENTION

In view of the disadvantages of the prior art enumerated above, it is an object of one aspect of this invention to provide a scraper for removing deposits from the exterior of a tubular member such as a protective quartz sheath, the scraper providing a scraper element for contacting the tubular member, the scraper element taking the form of an elongate resilient wire held within an outer jacket in such a way as to present segments of the wire extending along chords of aligned axial openings in such a way that the tubular member can be accommodated through the openings only by deforming the wire segments outwardly, whereby the resilience of the segments urges them against the tubular member and longitudinal movement of the scraper results in cleaning of the surface of the tubular member.

More particularly, in accordance with an aspect of the present invention is a scraper for the removal of deposits from the exterior of a tubular member, a scraper comprising:

an outer jacket defining an inwardly open circumferential recess and two aligned axial openings,

a scraper element in the form of an elongate resilient wire bent to define a series of integral, concatenated, resilient segments, each pair of adjacent segments being connected through a geniculation,

the geniculations being received within said recess with at least one segment extending substantially along a chord of the aligned axial openings,

whereby, in order to accommodate the tubular member through said aligned axial openings, the tubular member must deform said at least one segment outwardly, so that the resilience of the deformed segment urges it inwardly against the tubular member and causes it to clean the tubular member as the scraper moves axially relative to the tubular member.

According to another aspect of the present invention is a method of removing deposits from the exterior of a tubular member, the method comprising:

providing a scraper which includes:

an outer jacket defining an inwardly open circumferential recess and two aligned axial openings,
and a scraper element in the form of an elongate resilient wire bent to define a series of integral, concatenated, resilient segments, each pair of adjacent
5 segments being connected through a geniculation,
the geniculations being received within said recess with at least one segment extending substantially along a chord of the aligned axial openings,
and inserting the tubular member through said aligned openings so as to deform said at least one segment outwardly, whereby the resilience of the
10 deformed segment urges it inwardly against the tubular member and causes it to clean the tubular member as the scraper moves axially relative to the tubular member.

GENERAL DESCRIPTION OF THE DRAWINGS

15

Two embodiments of this invention are illustrated in the accompanying drawings, in which like numerals denote like parts throughout the several views, and in which:

20

Figure 1 is an exploded, perspective view of the main components of one embodiment of this invention;

Figure 2 is an axial sectional view of the primary components seen in Figure 1, also in exploded relation;

25

Figure 3 is an end elevation of the assembled scraper of which the parts are shown in Figures 1 and 2, illustrating the theoretical positioning of one segment of a scraper element (made of bent wire), to illustrate the principle of the invention;

Figure 4 is a view similar to Figure 3, showing a tubular member in transverse section passing through aligned openings of a jacket member, with the tubular member bending the scraper segment out of position, thus creating inward pressure, allowing the wire segment to clean a portion of the surface of the tubular member;

Figure 5 is an axial view of the scraper, showing a number of wire segments;

Figure 6 is an axial sectional view of a portion of the main holding element of the second embodiment, which is similar to the same element in Figure 2; and

Figure 7 is a schematic side elevation showing a tubular member, a scraper member, and means for moving the scraper member along the tubular member.

DETAILED DESCRIPTION OF THE DRAWINGS

Attention is first directed to Figure 1, which illustrates the four basic elements of the scraper 9 described herein. The four elements are seen in axially aligned but exploded relation, for clarity.

Shown at the extreme left in Figure 1 is an outer jacket 10, to the right of which is a scraper element 12, followed by a washer 14 and a circlip 16.

While Figure 1 shows only one washer 14 and one circlip 16, the complete assembly requires two washers and two circlips.

As best seen in Figure 2, the outer jacket 10 has the shape of a hollow circular cylinder with an outer cylindrical wall 18 and an inner cylindrical wall 20. In the inner cylindrical wall 20 are provided two spaced-apart grooves 22, each

adapted to receive a circlip 16. Each circlip 16 is sized so as to resiliently “snap” into position within the corresponding groove 22. As best seen in Figure 1, each circlip 16 is a penannular member, shaped such that the free ends 24 can resiliently approach each other to make the effective diameter smaller and allow it to be snapped into position.

The circlips 16 are spaced axially away from each other to allow the inclusion of the two washers 14, each lying immediately adjacent one of the circlips 16 (shown in broken lines within the jacket 10), and also containing the scraper element 12, this lying between the washers 14.

To avoid confusion, it should be explained that Figure 2 shows each circlip 16 in two positions: both outside and inside the jacket 10, and similarly, each washer 14 is shown both outside and inside the jacket 10. The inside positions for all such elements are in broken lines.

Returning to Figure 1, the scraper element 12 takes the form of an elongate resilient wire bent to define a series of integral, concatenated, resilient segments 26, with each pair of adjacent segments 26 being connected through a geniculation 28. The geniculations 28 are rounded. When so bent, the scraper element consists of a series of relatively straight portions connected in sequence by rounded portions. More accurately, the scraper element 12 of a preferred embodiment is formed by bending a resilient wire to form a series of approximate triangles with blunt apices, in such a way that each geniculation is at a location closely adjacent to, but not coincident with, the locations of the geniculations which are three segments away from the given geniculation in either direction.

The scraper element 12 is received within a recess defined by the jacket 10 and the two washers 14, this being identified by the numeral 30 in Figure 2.

As can be seen in Figure 5, the result of bending the elongate resilient wire into the shape seen in Figure 1 is that substantially all of the wire segments extend substantially along chords of the aligned axial openings 32 which are defined by the washers 14.

5

To illustrate theoretically what is happening, attention is directed to Figure 3, which shows only a single wire segment 26a extending along a chord of the opening 32. Comparing Figures 3 and 4, it will be seen that when a tubular member (shown in transverse section at 34 in Figure 4) takes up a central position within the opening 32, it can only do so by forcing the wire segment 26a outwardly. However, because the wire is resilient, it will seek to remain in the position of Figure 3, and its outwardly deflection will cause it to push inwardly against the outer surface of the tubular member 34, thus allowing it to carry out a scraping and cleaning action on the surface when the scraper 9 moves along the tubular member 34. By arranging for substantially all of the wire segments to press inwardly against the tubular member in the same way, there will occur a multiple scraping action which is highly effective and efficient.

As previously pointed out, Figure 5 is a more accurate depiction of the scraper configuration.

It should be further pointed out that the number of wire segments seen in Figure 1 is far less than the actual practical number (closer to about 100).

In the embodiment shown in Figure 6, the left side of the jacket 10a is changed to a simple inward projecting flange 36, which performs the same function as the leftward washer 14 (in Figure 2).

Thus, it can be seen that the jacket 10, 10a, with two or with one washer (held in place by a circlip 16) defines an inwardly open circumferential recess 30 and two aligned axial openings 32.

5 To enhance the scraping function of the scraper element 12, the resilient wire may be non-round in transverse section. Preferably the resilient wire has a polygonal cross-section, which, even more preferably, is a square cross-section.

10 It is to be understood that the scraper 9 would be mounted in association with means adapted to support it in a position from which it can surround the tubular member, and can be moved axially relative to the tubular member. This is schematically shown in Figure 7, depicting a tube 34, a scraper 9 connected to a carriage member 42 adapted to move longitudinally along a threaded screw 44. As the screw 44 is rotated, the carriage 42 will be moved to the left or to the right
15 (depending upon the sense of the rotation), and will carry the scraper 9 longitudinally of the tubular member 34.

20 While two embodiments of this invention have been illustrated in the accompanying drawings and described hereinabove, it will be evident to those skilled in the art that changes and modifications may be made therein without departing from the essence of this invention, as set forth in the accompanying claims.

**THE EMBODIMENTS OF THE INVENTION IN WHICH AN EXCLUSIVE
PROPERTY OR PRIVILEGE IS CLAIMED ARE DEFINED AS FOLLOWS:**

1. For the removal of deposits from the exterior of a tubular member, a scraper
5 comprising:

an outer jacket defining an inwardly open circumferential recess and two
aligned axial openings,

a scraper element in the form of an elongate resilient wire bent to define a
series of integral, concatenated, resilient segments, each pair of adjacent segments
10 being connected through a geniculation,

the geniculations being received within said recess with at least one segment
extending substantially along a chord of the aligned axial openings,

whereby, in order to accommodate the tubular member through said aligned
axial openings, the tubular member must deform said at least one segment
15 outwardly, so that the resilience of the deformed segment urges it inwardly against
the tubular member and causes it to clean the tubular member as the scraper moves
axially relative to the tubular member.

2. The scraper claimed in claim 1, in which the resilient wire is non-round in
20 transverse section.

3. The scraper claimed in claim 1, in which the resilient wire has a polygonal
cross-section.

25 4. The scraper claimed in claim 1, in which the resilient wire has a square
cross-section.

5. The scraper claimed in claim 1, in which the bending of the resilient wire is
such that a given geniculation lies within the recess at a location closely adjacent to,

but not coincident with, the locations of the geniculations which are three segments away from the given geniculation in either direction.

6. The scraper claimed in claim 1, in which the aligned openings are
5 substantially circular, and in which substantially all wire segments extend
substantially along chords of the aligned openings.

7. The scraper claimed in claim 1, in combination with means for supporting
the scraper in a position in which it can surround the tubular member, and can move
10 axially relative to the tubular member.

8. The combination claimed in claim 7, in which the bending of the resilient
wire is such that a given geniculation lies within the recess at a location closely
adjacent to, but not coincident with, the locations of the geniculations which are
15 three segments away from the given geniculation in either direction, all
geniculations being rounded.

9. The scraper claimed in claim 5, in which the resilient wire is non-round in
transverse section.
20

10. The scraper claimed in claim 5, in which the resilient wire has a polygonal
cross-section.

11. The scraper claimed in claim 5, in which the resilient wire has a square
25 cross-section.

12. The scraper claimed in claim 1, in which said outer jacket includes a
cylindrical outer member, a pair of annular washers adapted to fit within said outer
member in spaced-apart relation, and a pair of circlips for holding the washers in

place, the outer member having internal circumferential grooves for receiving the circlips.

13. A method of removing deposits from the exterior of a tubular member, the
5 method comprising:

providing a scraper which includes:

an outer jacket defining an inwardly open circumferential recess and two
aligned axial openings,

10 and a scraper element in the form of an elongate resilient wire bent to define
a series of integral, concatenated, resilient segments, each pair of adjacent
segments being connected through a geniculation,

the geniculations being received within said recess with at least one segment
extending substantially along a chord of the aligned axial openings,

15 and inserting the tubular member through said aligned openings so as to
deform said at least one segment outwardly, whereby the resilience of the
deformed segment urges it inwardly against the tubular member and causes it
to clean the tubular member as the scraper moves axially relative to the
tubular member.

