

(12) **UK Patent Application** (19) **GB** (11) **2 151 272 A**

(43) Application published 17 Jul 1985

(21) Application No **8431824**

(22) Date of filing **24 Nov 1982**

Date lodged **17 Dec 1984**

(30) Priority data

(31) **8135331** (32) **24 Nov 1981** (33) **GB**

(60) Derived from Application No **8233488** under Section 15(4) of the Patents Act 1977

(71) Applicant  
**Kimberley-Clark Limited (United Kingdom),  
Larkfield, Maidstone, Kent ME20 7PS**

(72) Inventors  
**Dr. Mansoor Ahmad Minto,  
Dennis Graham Storey,  
Dr. Geoffrey Robert Owen**

(74) Agent and/or Address for Service  
**Lloyd Wise Tregear & Co.,  
Norman House, 105-109 Strand, London WC2R 0AE**

(51) INT CL<sup>4</sup>  
**D04H 1/00**

(52) Domestic classification  
**D1R 105 151 200 203 308 309 310 318 354 461 502 512  
519 544 549 550 551 554 562 602 603 647 AA  
U1S 1122 D1R**

(56) Documents cited  
**GB A 2060018** **GB 1088293**  
**GB 1581486** **GB 0953709**  
**GB 1493183**

(58) Field of search  
**D1R**

(54) **Absorbent microfibre web**

(57) A method of making a non-woven web of melt blown polymeric fibres wherein the melt blown fibres have particles introduced into the stream of microfibrils after the microfibrils have been extruded. If the particles are of super absorbent material they are distributed substantially individually and spaced throughout the web and provide effective results when used for example in a sanitary napkin, diaper or incontinence pad. If the particles are for example, clay, calcium carbonate, kaolin chalk or the like, then a wiper product made from the web has improved wiping properties.

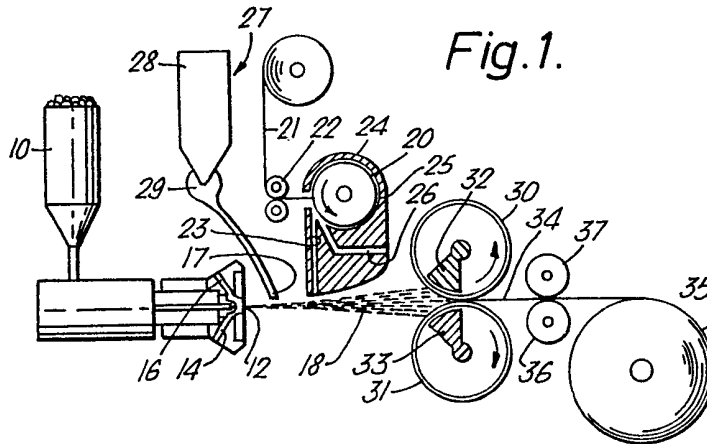

**GB 2 151 272 A**

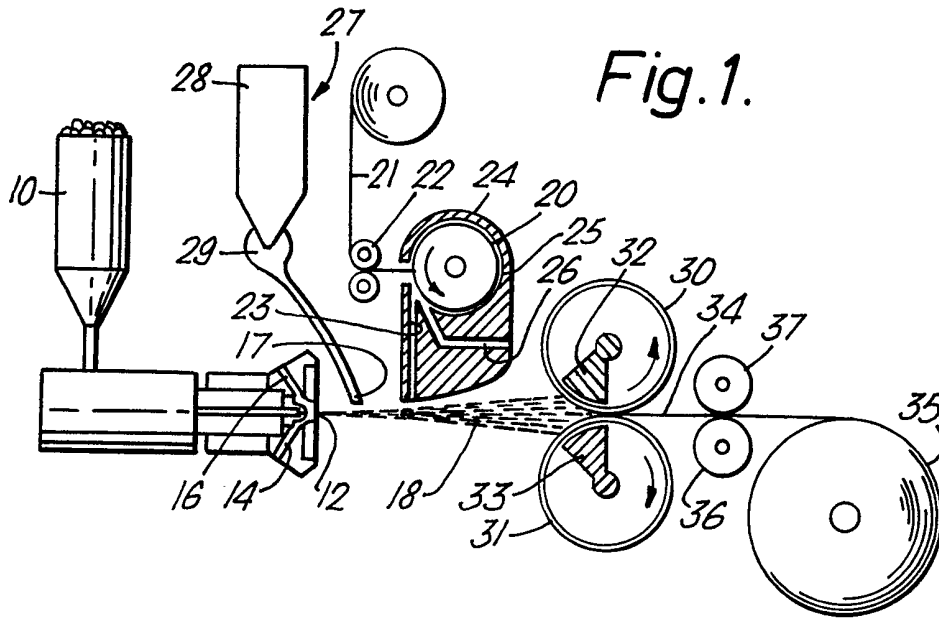

Fig. 2.

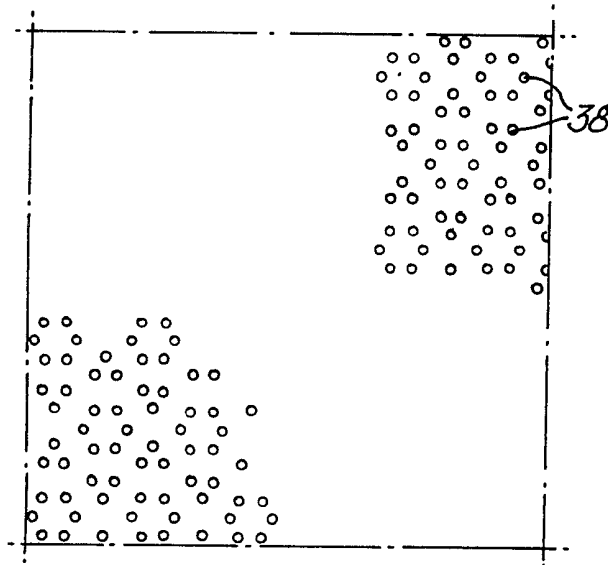
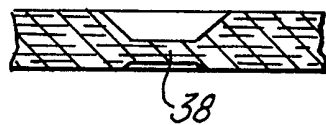

Fig. 3.



2/10

2151272

Fig. 4.



ICCL/12-80/C

5,500X  
(1cm = 1.82 $\mu$ m)

3/10

Fig. 5.

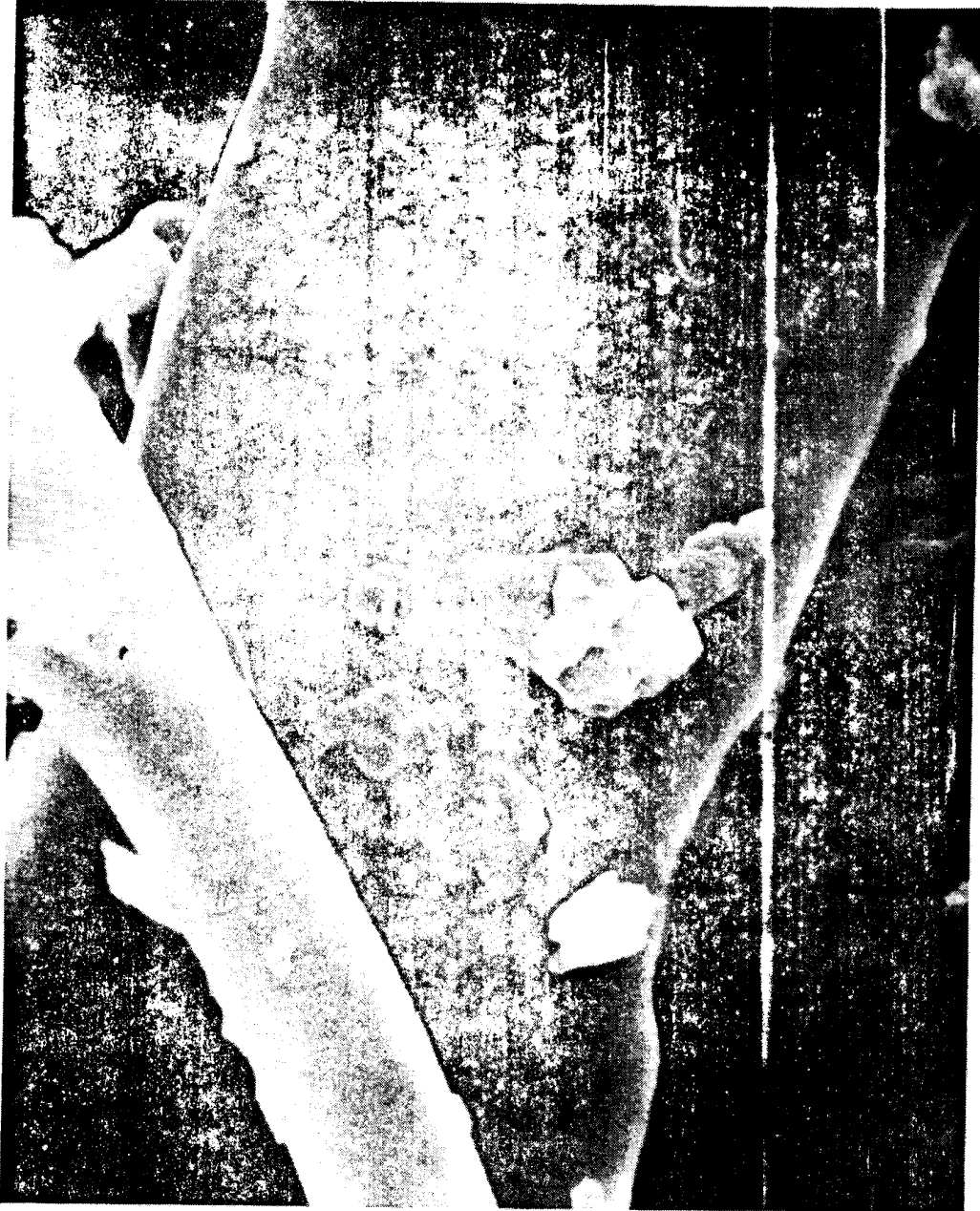

1CCL/12-80/C

18,000X  
(1cm = 0.56μm)

4/10

Fig. 6.



1CCL/12-80/D

550X  
(1cm = 18 $\mu$ m)

Fig. 7.

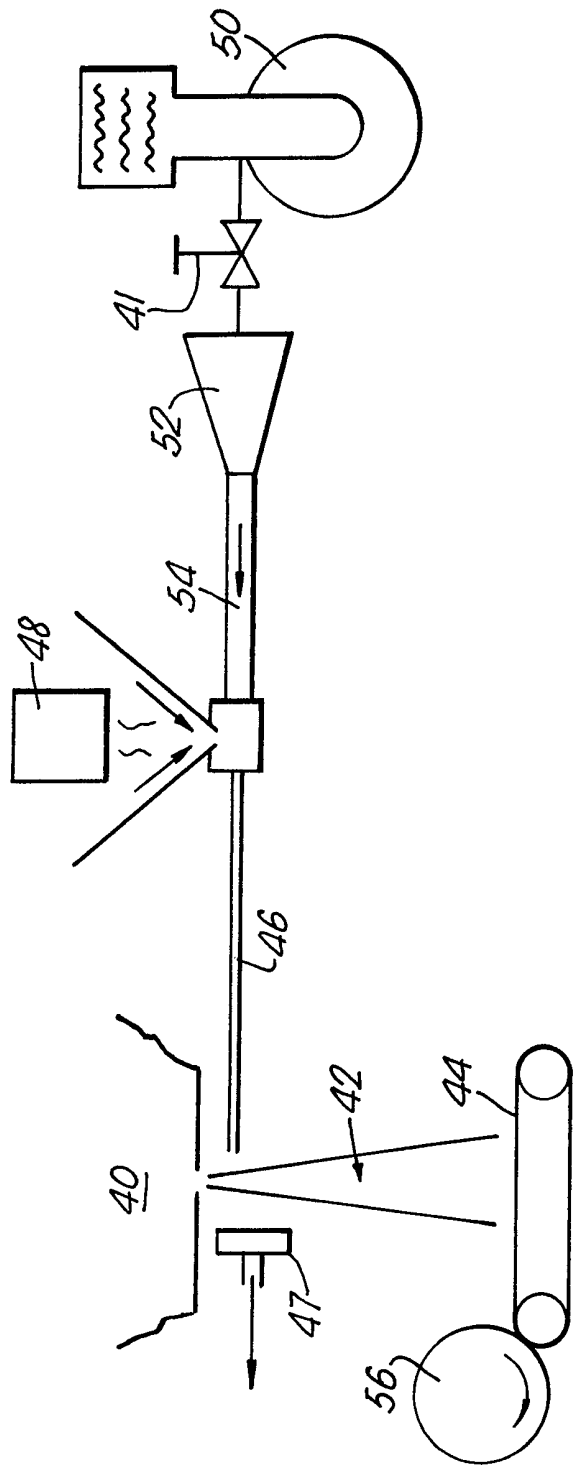
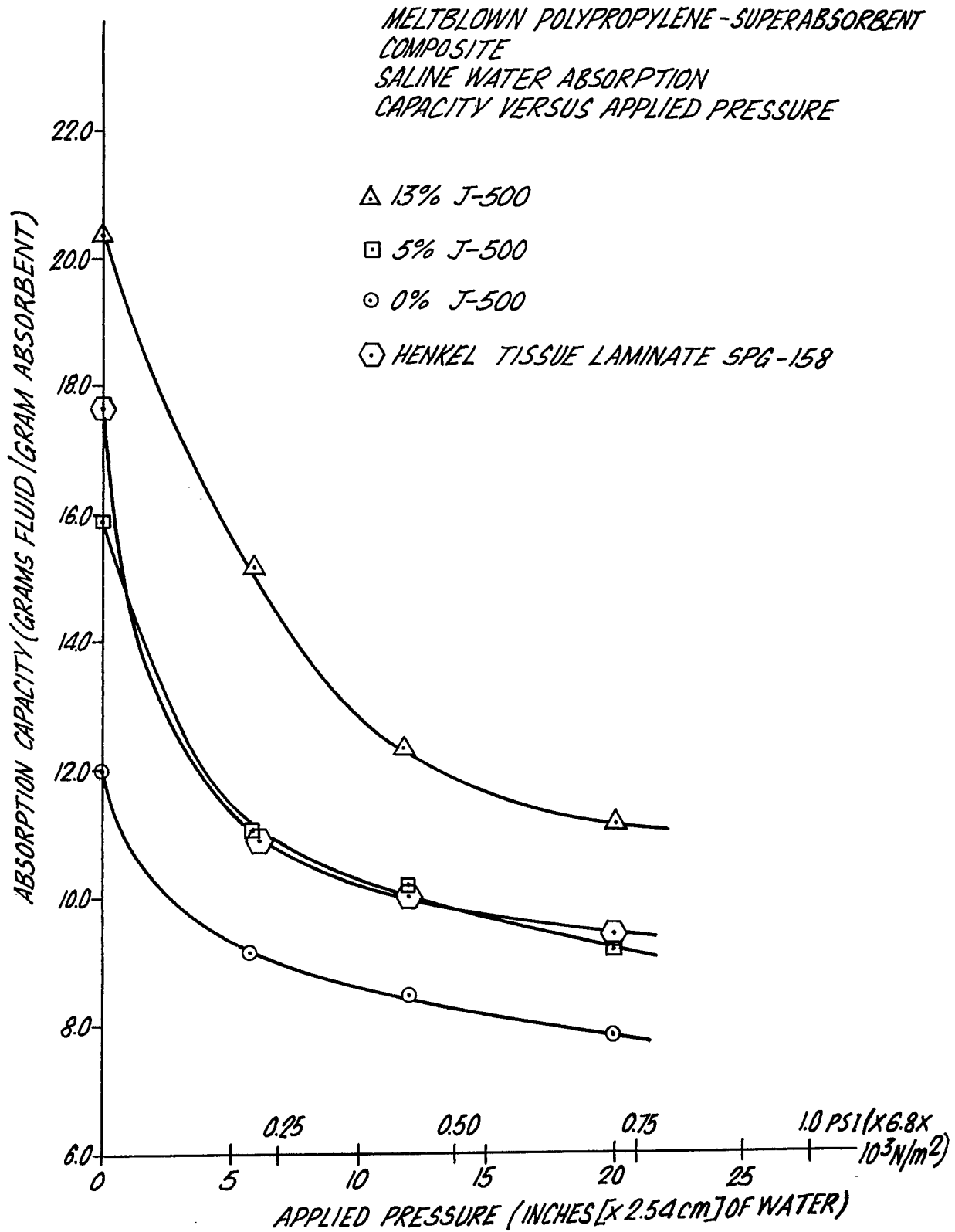

Fig. 8.



7/10

Fig. 9.

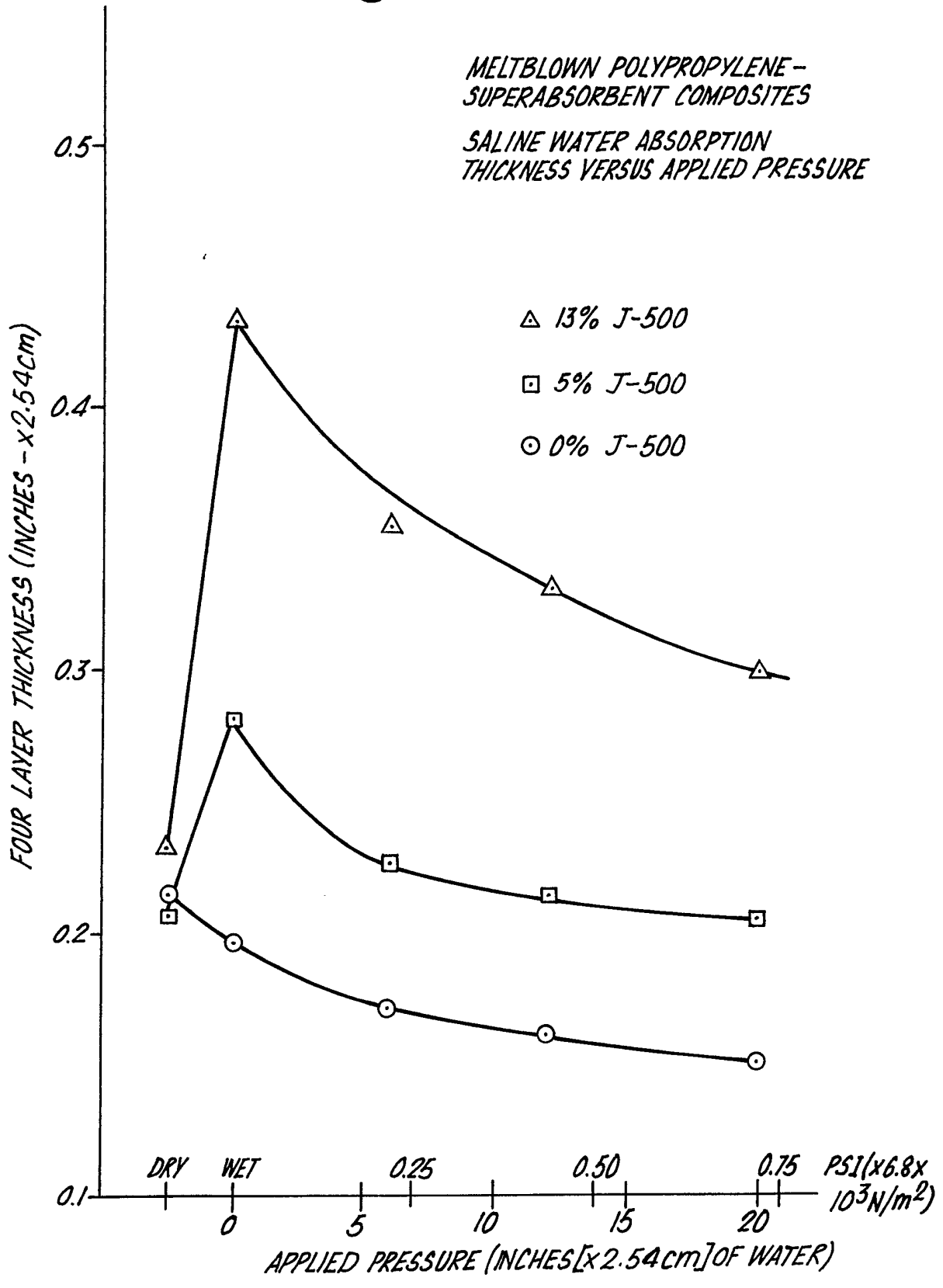
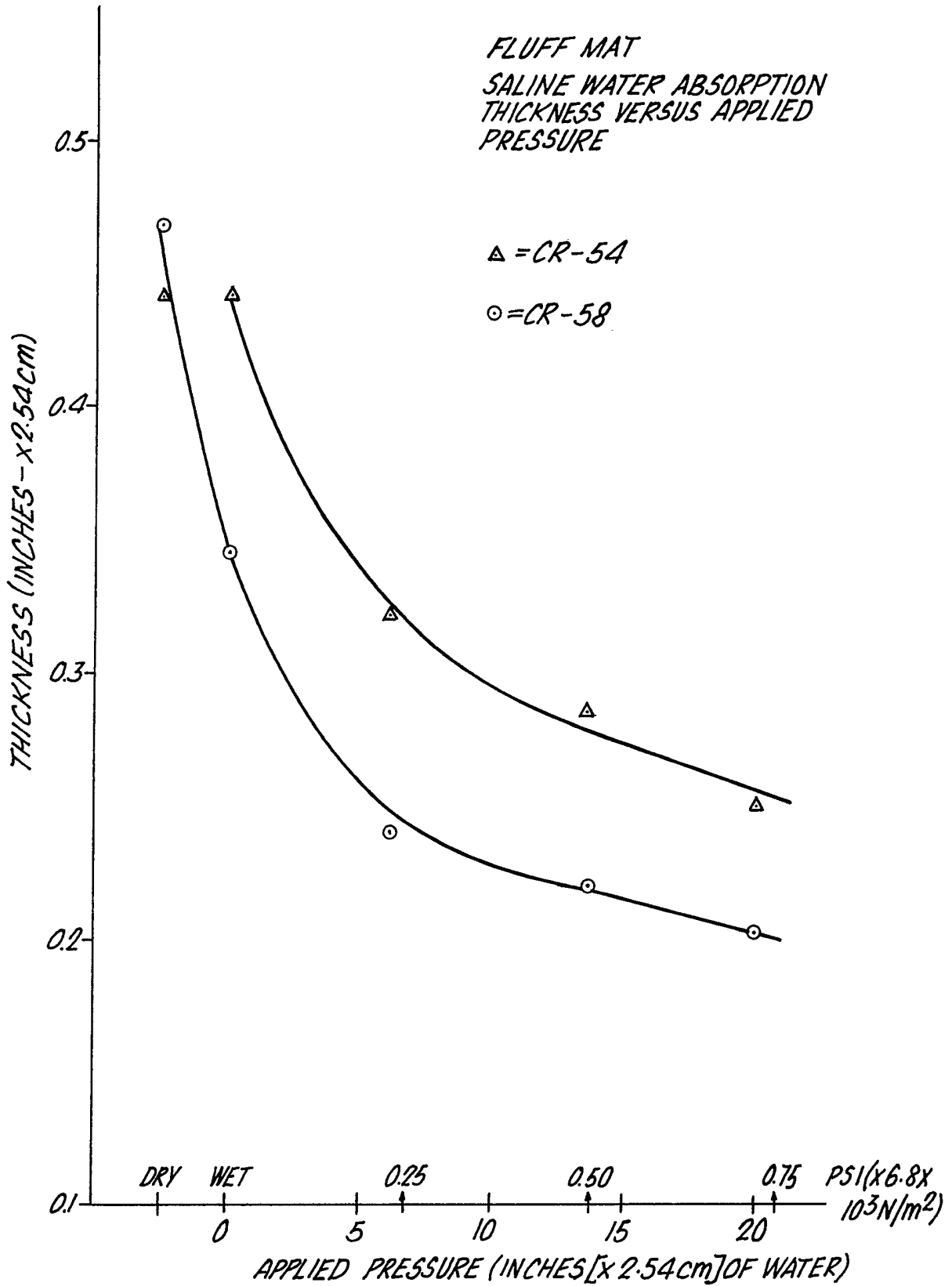

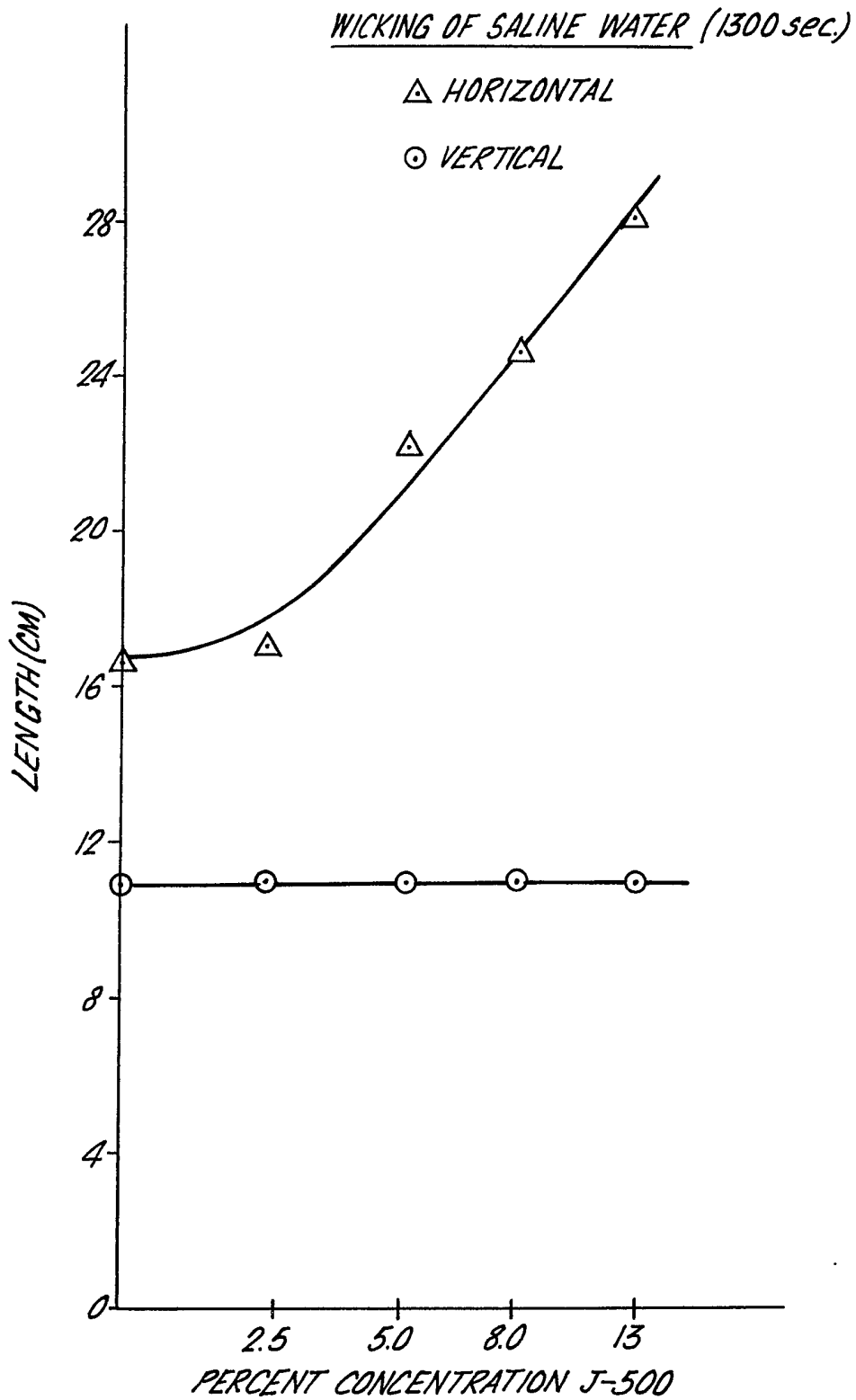

Fig.10.



9/10

Fig.11.



10/10



17% J-500 SAM  
face

Fig.12.

180X  
(1cm=56μm)

## SPECIFICATION

**Microfibre web product**

- 5 This invention relates to non-woven fabrics and in particular to those comprising a matrix of melt blown polymer fibres and a method of producing these. 5
- Fabric made from melt blown polymer fibre is well known and is described for example in British Patent No. 2,006,614, British Patent No. 1,295,267 and U.S. Patent No. 3,676,242. Such a fabric will be referred to hereafter as M.B.P.F.
- 10 Fabric of melt blown polyolefin fibres is useful as wiping cloths for oil and when this is additionally treated with a wetting agent, as proposed in British Patent No. 2,006,614 is has excellent oil and water wiping properties. When the fabric is also treated by a pattern bonding process it is strong and durable. However, such fabric is relatively expensive when compared with disposable wipers derived from creped tissue or paper. 10
- 15 It is also known to treat M.B.P.F. to make it suitable for use as a filter. This is done by incorporating particles such as activated carbon or alumina without the use of binders, by intermixing with the fibres. The particles are retained by mechanical entanglement with the fibres and do not adhere to the microfibrils. Such material is unsuitable for use as a wiper since the particles are not sufficiently well retained and would tend to "dust out" or drop out of the material if used as a wiper. 15
- 20 A non-woven fabric in accordance with this invention comprises melt blown thermoplastic (preferably polymeric) microfibrils and absorbent particles or granules, the particles or granules being firmly adhered to the fibres by being brought into contact with the fibres whilst the fibres are still in a tacky condition. 20
- A method of making a non-woven fabric in accordance with the invention comprises extruding a molten polymeric material to produce a stream of melt blown microfibrils and directing absorbent particles into the stream whilst the fibres are tacky so that the particles adhere to the fibres subsequently quenching the fibres or otherwise allowing the fibres to cool, and then forming or consolidating the fibres into a mat. 25
- 25 The particles in the resulting fabric web are held firmly even if the fabric is abraded or torn when used as a wiper.
- The particles are preferably blown onto the stream of particles shortly after the fibres leave an extrusion nozzle and the particles may be given an electrostatic charge prior to contacting the fibres which helps to separate the particles in the web. 30
- 30 Other fibres such as wood pulp fibres or staple textile fibres (e.g. cotton) may also be introduced preferably simultaneously with the absorbent particles.
- 35 Preferably the fibres of the M.B.P.F. have a diameter between 1 and 50 microns, with most fibres preferably less than 10 microns. The fibres may, for example, be of polyester, polypropylene or nylon. 35
- A wetting agent may be added to improve the water absorbency properties.
- 40 The particles, when the fabric is to be used, for example, as an industrial or catering wiper may be of a wide range of low cost absorbent granular materials such as clay, kaolin, talc, calcium carbonate, sodium sulphate, sodium carbonate or aluminium oxide. It is also possible to use granular organic materials such as sponge particles. Calcined clay, particularly calcined china clay, is very useful. This has a crystalline structure and produces granules normally hollow, which are more absorbent than other clay material. 40
- 40 The particles may be relatively small, e.g. 1 micron or less up to 100 microns or larger and may be incorporated as individual particles or as clusters.
- 45 Particles of super absorbent material are very preferably employed to produce a web characterized by the presence of the super absorbent particles which are distributed substantially individually and spaced throughout the web. 45
- 50 Particulate super absorbent material (e.g. modified starch or cellulose or alginate) when added to the molten melt blown microfibrils produces a web with significant unexpected benefits. The resultant web utilises the excellent wicking properties of melt blown micro fibres, i.e. the high capillary attraction present between microfibrils, to rapidly convey fluid to the finely dispersed individual super absorbent particles. This isolation of the individual particles can imbibe fluid without substantial interference from gel blocking. Isolation may, for example, be produced by giving the particles an electrostatic charge before feeding them into the stream of fibres. 50
- 55 Gel blocking occurs when a mass of super absorbent swells upon imbibation. This swelling acts to substantially diminish the size of the capillaries in the super absorbent mass and may, in fact, close them. While other attempts at providing maximum surface per weight have been utilised, none have utilised individual isolated super absorbent particles in combination with melt blown microfibrils to provide this superior wicking in combination with absorbent efficiency. 55
- 60 During imbibation the entire microfibre super absorbent composite swells but there is still isolation of individual particles of super absorbent. Therefore, while swelling occurs, gel blocking does not. This is true even at high levels of super absorbent addition to the composite and in fact a proportional increase in capacity and horizontal wicking is observed. 60
- 65 The particles of super absorbent material have relatively large diameter compared to the diameter of the individual microfibrils and thus tend to be trapped within a network of the fibres and therefore little surface tack of the fibres is needed to maintain the super absorbent particles in place. 65

Webs with super absorbent particles may, for example, be used in sanitary napkins, diapers, incontinence pads or the like.

The particle size in one embodiment of the invention, using calcined china clay is 25% less than 2 microns, 28% greater than 10 microns and 3% greater than 20 microns. In this embodiment the clay was incorporated in a melt blown matrix of polypropylene at levels of approximately 6% and 14% and at a basis weight of approximately 90 g/m<sup>2</sup>. It is considered that the particle size range should be between 1 and 100 microns with amounts of calcined clay of 5 to 40%. An increase of clay over 40% may tend to weaken the resultant product whilst not appreciably increasing the absorption capacity for water and/or oil.

It has been found that the clay particle additive significantly decreases the product cost by reducing the polymer content required per weight of the product.

The oil (SAE 10) absorptive capacity of the product with clay particles was found to be 1 to 2 grams of oil per gram of calcined clay.

In order to increase its strength, M.B.P.F. in accordance with the invention may be hot calendered or embossed with heated patterned bonding rolls. The fabric may also be perforated as described and claimed in our co-pending British Application No. 8135330 filed simultaneously herewith. This further improves the absorbency and wiping properties of the fabric.

The invention will now be further described by way of example with reference to the accompanying drawings in which:-

*Figure 1* is a partly schematic side elevation of an apparatus for producing fabrics according to the present invention;

*Figure 2* is a plan view of a fragment of fabric according to the present invention which has been embossed;

*Figure 3* is a cross-section of one form of embossment in the fabric of *Figure 1*;

*Figures 4 and 5* are electron microscope photographs of clay filled fabric of the present invention taken with a magnification of 5500 and 18,000 times;

*Figure 6* is an electron microscope photograph of a fabric having cellulose sponge particles;

*Figure 7* is a diagrammatic illustration of an alternative apparatus for producing webs in accordance with the invention;

*Figure 8* is a graph comparing saturated capacity of super absorbent composites against a tissue laminated super absorbent versus applied pressure;

*Figure 9* is a graph showing the volume (thickness) of microfibre super absorbent composites versus applied pressure;

*Figure 10* is a graph showing the volume (thickness) of wood fluff absorbent versus applied pressure;

*Figure 11* is a graph showing the wickening of super absorbent composites versus percent concentration, and

*Figure 12* is an electron microscope photograph of fabric with super absorbent particles.

Referring to *Figure 1*, discontinuous thermoplastic polymeric material from a hopper 10 is heated and then caused to flow through nozzle 12 whilst being subjected to air jets through nozzles 14, 16 which produces a final stream 18 containing discontinuous microfibrils of the polymeric material. This is known as melt-blowing and the technique is further described in an article entitled "Superfine Thermoplastic Fibres" appearing in *Industrial and Engineering Chemistry*, Vol. 48, No. 8, pp 1342 - 1346 which describes work done at the Naval Research Laboratories in Washington D.C. Also see Naval Research Laboratory Report No. 11437 dated 15th April 1954, U.S. Patent No. 3,676,242 and U.S. Patent No. 4,100,324 issued to Anderson et al.

The apparatus shown in *Figure 1* is generally the same as described in U.S. Patent No. 4,100,324 with the exception of two particular features which will be described hereinafter and the subject matter of that patent is to be considered as being included in the present specification and will not be further described. The subject matter of U.S. Patent No. 3,793,678 entitled "Pulp Picking Apparatus with Improved Fibre Forming Duct" is also to be considered as being included in the present specification insofar as the picker roll 20 and feed 21 to 26 are concerned, as also described in U.S. Patent No. 4,100,324.

The picker roll 20 and associated feed 21 to 26 are an optional feature of the apparatus of *Figure 1* and are provided to enable the introduction of fibrous material into the web of the invention if this is required.

The picker device comprises a conventional picker roll 20 having picking teeth for divellicating pulp sheets 21 into individual fibres. The pulp sheets 21 are fed radially, i.e., along a picker roll radius, to the picker roll 20 by means of rolls 22. As the teeth on the picker roll 20 divellicate the pulp sheets 21 into individual fibres, the resulting separated fibres are conveyed downwardly toward the primary air stream through a forming nozzle or duct 23. A housing 24 encloses the picker roll 20 and provides a passage 25 between the housing 24 and the picker roll surface. Process air is supplied to the picker roll in the passage 25 via duct 26 in sufficient quantity to serve as a medium for conveying the fibres through the forming duct 23 at a velocity approaching that of the picker teeth. The air may be supplied by any conventional means as, for example, a blower.

It has been found that, in order to avoid fibre floccing, the individual fibres should be conveyed through the duct 23 at substantially the same velocity at which they leave the picker teeth after separation from the pulp sheets 21, i.e., the fibres should maintain their velocity in both magnitude and direction from the point where they leave the picker teeth. More particularly, the velocity of the fibres separated from the pulp sheets 21 preferably does not change by more than about 20% in the duct 23. This is in contrast with other forming

apparatus in which, due to flow separation, fibres do not travel in an ordered manner from the picker and, consequently, fibre velocities change as much as 100% or more during conveyance.

Further details of the picker device may be found in U.S. Specification No. 4,100,324. The particular differences between the apparatus shown in Figure 1 of the present specification and that of Figure 1 of U.S. Patent No. 4,100,324 is the means 27 for introducing particulate absorbent material into the melt blown fibre stream 18. The particle introduction means comprises a hopper 28 and air impeller 29 so arranged that the particles are ejected as a stream through a nozzle 17 into the fibre mat shortly after the nozzle 12 and whilst the melt blown fibres remain unset and tacky. The particles stick to the tacky fibres and are distributed throughout the fibre mat.

The fibres then cool as they continue in their path and/or they may be quenched with an air or water jet to aid cooling so that the fibres are set, with the particles adhered to them, before the fibres are formed into a web as described hereafter.

It is also possible to introduce the absorbent particles through the picker roll 20 and nozzle 23 either as an independent stream of particles or together with a stream of wood pulp fibres or a stream of staple textile fibres.

The hot air forming the melt blown fibres is at similar pressures and temperatures to that disclosed in U.S. Patent No. 4,100,324.

The set fibres and particles are condensed into a web by passing the mat of fibres between rolls 30 and 31 having foraminous surfaces that rotate continuously over a pair of fixed vacuum nozzles 32 and 33. As the integrated stream 18 enters the nip of the rolls 30 and 31, the carrying gas is sucked into the two vacuum nozzles 32 and 33 while the fibre blend is supported and slightly compressed by the opposed surfaces of the two rolls 30 and 31. This forms an integrated, self-supporting fibrous web 34 that has sufficient integrity to permit it to be withdrawn from the vacuum roll nip and conveyed to a wind-up roll 35.

Alternatively, the web may be formed on a moving wire screen. The web is then further processed and bonded by hot calendering, embossing or perforating, or by ultrasonic embossing.

Heated embossing rolls 36 and 37 are provided as more fully described in our co-pending British Application No. 8135330. These rolls are driven at different speeds and the consolidated fibre web is passed between the rolls to emboss the web and bond it. The differential speed of the rolls causes the relatively outer fibres to be in effect lifted or "brushed up" giving an enhanced thickness to the web.

The embossments on the roll may extend further from the roll surface than the thickness of the web which also aids in achieving an enhanced web product.

Fabrics made with the apparatus shown in Figure 1 and with the apparatus shown but with the embossing head 40 and anvil roll 41 of U.S. Patent No. 4,100,324 replacing rolls 36 and 37 are shown in Figure 2, with the embossment indicated at 38 (see also Figure 3).

The primary feature of the invention is the inclusion of particulate material into the M.B.P.F. This is achieved by directing the particles through a nozzle into the stream of microfibrils as they leave the die head, whilst the microfibrils are still tacky and the particles adhere to the microfibrils or even become partially embedded in them. Figures 4 to 6 clearly show that the particles are adhering to the microfibrils or have become partially embedded in the fibres.

One preferred particulate material is calcined English China Clay, samples of which are listed below in Table 1.

TABLE 1

	<i>Clay Samples No.</i>	<i>Source</i>	<i>Clay Code</i>	
45	1	Laporte Industries Ltd., Luton, Beds.	SKY22/44 (S)	45
50	2	BDH Chemicals Ltd. Poole, Dorset.	33058	50
55	3	English China Clay International, St. Austell, Cornwall.	ar-501	55
	4	" "	M-100	
	5	" "	Superfill	
60	6	" "	SPS	60
	7	" "	ECR	
65	8	" "	Al.BP	65

Other European clays, particularly Spanish and Italian clays, may be used.

Other particulate material such as talc, calcium carbonate, sodium sulphate, kaolin, calcium sulphate, sodium carbonate, aluminium oxide or silica may be used.

5 Screening studies of the clays listed in Table 1 for fluid holding capacity, rate of wickability and bulk density are given in Tables 2, 3 and 4 respectively. The Tables are set out at the end of this specification. 5

10 A comparative study of results in Table 2 shows that for water fluid holding capacity (gram/gram) Clay No. 1 is the best followed by Clay No. 5. The remaining clays performed reasonably well except Clay Nos. 3 and 4. The poor performance of these could be attributed to the fact that the particle size is well below the optimal required for water, very fine particles were lost during use, and the void volume is low. The particles size in Clay Nos. 3 and 4 were generally 20% less than 1 micron, 50% less than 2 microns and 10% greater than 10 microns. 10

15 On the other hand the oil (SAE-10) holding capacity for Clay 2, 3, 4, 6 and 7 is good and the performance of the remaining three is not bad. Results in Table 2 seem to indicate that the lower range of particles in the particle size distribution appear to have a positive contribution, due mainly to increased surface area, towards the oil holding capacity of the clay. 15

20 Improvements in the performance of the fabric in accordance with the invention is achievable by the use of surfactants such as described in British Patent No. 2,006,614. It is also possible to include fibrous material as disclosed in U.S. Patent No. 4,100,324 by the means disclosed therein. Granular organic materials may also be incorporated and particles of cellulose sponge have been used as illustrated in Figure 6. The water absorbent properties of the sponge contribute to the performance of the fabric as a water wipe. The sponge particle in Figure 6 has a dimension of about 0.16 mm in one direction. 20

TABLE 2

Clay no.	For water		For oil (SAE-10)		Particle size distribution (microns)
	Atmospheric pressure ( $3.8 \times 10^3 \text{ N/m}^2$ )	Approx. 3 p.s.i. ( $2 \times 10^4 \text{ N/m}^2$ )	Atmospheric pressure ( $6.8 \times 10^3 \text{ N/m}^2$ )	Approx. 3 p.s.i. ( $2 \times 10^4 \text{ N/m}^2$ )	
1	2.00	1.69	0.95	0.77	+100
2	0.81	0.31	1.74	1.06	≈2-20
3	0.31*	0.22*	1.98		<1 (20%) <2 (50%) >10 (10%)
4	0.32*		2.01	1.41	
5	1.16	1.03	0.95	0.84	<2 (15%) >10 (35%)
6	0.76	0.37	1.54	1.58	<2 (80%) >10 (0.2%)
7	0.72		2.21	1.39	<2 (25%) >10 (28%)
8	0.66		1.18	0.95	<2 (78%) >5 (0.5%)

## Notes

50 1. The results of this table should only be considered for a relative comparison between the 8 different clays. 50

2. \*Some of the fine particles were washed down with water through and along the sides of the Whatman Filter Paper No. 1.

TABLE 3

*Rate of Wetting: Wickability**Basis: 10 gram of material (Clay)*

	<i>Sample No.</i>	<i>Rate (Seconds)</i>	<i>Colour</i>	<i>Moisture Content %</i>	
5					5
10	1.	13	Brown	2.1	10
	2.	240	Off White	0.8	
	3.	350	Pale	2.2	
15	4.	152	White	0.4	15
	5. (Lumps)	724	Pale	14.4	
20	6.	345	White	1.1	20
	7.	240	White	0.3	
	8.	585	Off White	0.4	
25					25

An alternative apparatus for use in producing a web in accordance with the invention and which is particularly suitable for the production of a web having particles of super absorbent material therein, is illustrated in Figure 7.

30 The melt blown fibres are produced by a device similar to that illustrated in Figure 1 and which is diagrammatically shown at 40 in Figure 7. The stream 42 of fibres passes downwardly towards a screen collector 44 on which the fibres are consolidated into a web.

35 Particles of super absorbent material are blown onto the mat of melt blown fibres through a nozzle 46 shortly after the fibres leave the outlet nozzle of the melt blown extruder apparatus 40. The air stream has a velocity of about 6,000 feet per minute. This speed is adjusted by valve 41 so that the majority of the particles are just trapped by the melt blown fibres and do not pass through to the dust catcher 47. The speed may be adjusted according to the weight and size of the particles and may vary from say about 4,000 to say 7,000 feet per minute and dust is caught by a dust catcher 47.

40 The particulate super absorbent material is held in a particle dispenser 48 which may be that known as Model 500 made by the Oxi-Dry Corporation of Roselle, New Jersey, U.S.A., and is metered into an air stream formed by an air blower 50 passing through an air diffuser 52 and an air straightener 54. The powder in the dispenser is fed using an engraved metal roll in contact with two flexible blades. The cavity volume of the roll, roll speed and particle size control feed rate. An electrostatic charge is desirably applied to the particles to promote individual particle separation in the composite, as gravity drops the particles into the air stream.

45 High turbulence at the conversion of the separate air streams, one containing fibre and the other particulate super absorbent, results in thorough mixing and a high capture percentage of the particulates by the microfibre. The particles are thus distributed substantially individually and spaced throughout the web formed from the fibre/particle mix by collecting it on the moving screen 44. It is then wound, as a non-woven fabric, onto a roll 56.

50 As an example, polypropylene microfibre made from EXXON 3145 polypropylene resin from Exxon Chemical Company, Houston, Texas was prepared in accordance with the procedure generally known as melt blowing. It is described in article "Super Fine Thermoplastic Fibres", appearing in INDUSTRIAL AND ENGINEERING CHEMISTRY, Volume 48, No. 8, Pages 1342 to 1346 and in U.S. Patents Nos. 3,676,242 and 4,100,324.

55 A surfactant is applied to the microfibrinous polypropylene at levels of 0.1 to 1.5 percent by weight to make the fibres wettable to aqueous solutions. In this Example, AEROSOL OT made by American Cyanamid Company, Wayne, New Jersey, was sprayed onto the fibres from dilute solution to an add on level of 0.27 percent by weight of fibre.

60 The powdered super absorbent used in this example was WATER-LOCK J-500 made by Grain Processing Corporation, Muscatine, Iowa.

Four separate sample composites were made having 2.4, 5.1, 8.1 and 13 percent by composite weight respectively of super absorbent.

Several tests of the samples were prepared as indicated below.

65 The first test performed was a saturated-capacity test. This test measures fluid holding capacity. Samples



are cut, weighed, placed on a screen and submerged in a saline (0.85% NaCl) water bath for five minutes.

Saturated samples are removed from the bath and allowed to drain for two minutes. The sample is weighed and fluid weight absorbed is recorded as grams fluid per gram absorbent.

Fluid is then removed from the saturated sample using pressure applied with a vacuum box, a flexible rubber sheet and a screen support. Fluid retained after applying pressure for one minute is again measured by sample weights. 5

The second or horizontal wicking test measures distance of fluid migration as a function of time.

Sample strips 4 cm. wide by 50 cm. long were prepared and placed in a horizontal geometry on a plexiglass plate. A test fluid is put in a reservoir on one edge of the plate. One end of the samples are extended several centimetres off, the end of the plate and simultaneously pressed into the fluid. Distance wicked as a fraction of time is marked on the plate with ink and then recorded at the completion of each experiment. 10

A vertical wicking test on the samples was then performed. This test measures vertical distance wicked as a function of time.

Strips prepared as above are suspended vertically and the lower ends dipped into a fluid reservoir to a depth of 3.5 cm. Distance wicked above the fluid reservoir is recorded at specific time intervals. 15

#### *Test results*

Saturated capacity of the microfibre super absorbent composites versus the microfibre control is shown in Figure 8. At zero pressure the control microfibre absorbs 12 grams fluid/gram absorbent. With 13 percent super absorbent in the microfibre the absorption capacity is 20.4 grams fluid per gram of absorbent (showing a 70 percent increase in capacity). The fluid used in this example is dilute saline solution (0.85 percent by weight). 20

**Results** 25

For comparison, a tissue laminated super absorbent (SPG 157 from Henkel Chemical Co., Minneapolis, Minnesota, U.S.A.), are also shown in Figure 8. Results show the tissue laminate capacity to be 17.5 grams fluid per gram absorbent at zero pressure. The 13 percent J-500 composite demonstrates a 16.6 percent saturated capacity increase over the tissue laminate.

As pressure is applied all the materials release some fluid. The capacity advantage of the composite is maintained to pressures of at least 0.75 pounds per square inch. 30

The volume (thickness) of the microfibre super absorbent composites is maintained better than microfibre and better than wood fluff absorbent (Figures 9 and 10). The super absorbent composites actually increase in volume as fluid is absorbed.

Horizontal wicking of the super absorbent composites versus an untreated microfibre control member (Figure 11) show that the composites have better fluid transfer rates. Comparing horizontal wicking of the 13 percent J-500 composite to the Henkel laminated tissue SPG 157 shows the composite to wick 18.8 cm. after 600 seconds and the laminated tissue wicks 11.2 cm. This demonstrates a 67.9 percent increase in horizontal wicking for the composites over a commercially available product. 35

Vertical wicking shows that the superabsorbent composites have the same wicking properties as the microfibre control. No evidence of gel blocking is seen. 40

Comparing vertical wicking of 13 percent J-500 composite to the Henkel Laminated Tissue SPG-157 shows the composite to wick 11.1 cm., after 1300 seconds and the laminated tissue wicks 7.4 cm. This demonstrates a 50.0% increase in vertical wicking for the J-500 composite over a commercially available product. 45

**Summary of results** 45

The microfibre composites containing Water-Lock J-500 absorbent shows improved absorbency characteristics of capacity and wicking over commercially available Henkel Laminated Tissue SPG-157 and also improvements over the currently produced microfibre without particle injected absorbents.

The particles of super absorbent material may have a relatively large diameter compared to the diameter of the individual microfibrils and thus tend to be trapped within a network of the fibres and therefore little surface tack of the fibres is needed to maintain the super absorbent particles in place. 50

Figure 12 is an electron microscope photograph of one example of web in accordance with the invention including particles 60 of super absorbent material. The photographs are of a sample having 17% by weight of super absorbent to fibre material and are to a magnification of one hundred and eighty times. The maximum particles dimensions of the particles illustrated are between  $122 \times 139$  microns and  $168 \times 213$  microns and it can be seen that the particles are distributed substantially individually and spaced in the web sample. 55

#### CLAIMS

60

1. A method of making a non-woven web comprising extruding a molten polymeric material in such a way as to produce a stream of melt blown polymeric microfibrils, directing absorbent particles into the stream of microfibrils whilst the fibres are in a tacky state so that the particles adhere to the fibres subsequently quenching the fibres or otherwise allowing them to cool so that the fibres are set and then

65 forming or consolidating the set fibres into a web. 65

2. A method of making a non-woven web comprising extruding molten polymeric material in such a way as to produce a stream of melt blown polymeric microfibrils, directing particles of super absorbent material into the stream of microfibrils and then forming or consolidationg the fibres into a web with the particles distributed substantially individually and spaced throughout the web.
- 5 3. A method as claimed in Claim 1 or 2 in which the particles are blown onto the stream of fibres shortly after the fibres leave an extrusion nozzle. 5
4. A method as claimed in any one of Claims 1 to 3 in which the particles are given an electrostatic charge prior to contacting the fibres.
5. A method as claimed in any one of the preceding claims in which the particles are injected into an air stream prior to the air stream impinging on the fibres. 10
6. A method as claimed in Claim 5 in which the velocity of the said air stream is adjusted so that the majority of the particles are trapped by the melt blown fibres and do not pass through the fibre stream.
7. A method as claimed in Claim 6 in which the said air stream has a velocity of about 6000 feet per minute.
- 15 8. A method as claimed in Claim 1 or 2 in which the web is hot calendered or embossed by passing it between heated patterned bonding rolls. 15
9. A method as claimed in Claim 8 in which the depth of the embossing member on the patterned roll is greater than the thickness of the web.
10. A method as claimed in either Claims 8 or 9 in which the embossing rolls are driven at different speeds. 20
11. A method as claimed in any of Claims 1 to 10 in which other fibres are introduced into the stream of microfibrils prior to formation of the fibres into a web.
12. A meltblown microfibre web characterised by the presence of superabsorbent particles distributed substantially individually and spaced throughout said web.
- 25 13. A web as claimed in Claim 12 wherein the particles bear an electrostatically derived charge prior to contact with the web. 25
14. A web of melt blown thermoplastic microfibre and absorbent particles or granules, the particles or granules being firmly adhered to the fibres by being brought into contact with the fibres whilst the fibres are still in a tacky condition.
- 30 15. A web as claimed in any of Claims 12 to 14 having wood pulp or staple textile fibres intermingled with the melt blown thermoplastic fibres. 30
16. A web as claimed in any of Claims 12 to 15 in which the fibres of the melt blown thermoplastic material have a diameter of between 1 and 50 microns.
17. A web as claimed in any of Claims 12 to 16 in which the particles have a maximum dimension of between 1 and 100 microns. 35
18. A web as claimed in any of Claims 14 to 17 in which the particles are clay, kaolin chalk, calcium carbonate, sodium sulphate, sodium carbonate, aluminium oxide or calcined china clay.
19. A web as claimed in any of Claims 14 to 18 including particles of organic material, e.g. sponge.
- 40 20. A sanitary napkin, diaper, incontinence pad or the like including a web containing substantially individual spaced particles of super absorbent material as claimed in any of claims 12 to 17. 40
- Amendments to the claims have been filed, and have the following effect:-
- (a) Claims 1-20 above have been deleted.
- (b) New claims have been filed as follows:- 45
- 45 1. A fluid retentive web comprising entangled meltblown microfibrils and absorbent particles held within the web, the particles being distributed substantially individually and spaced throughout the web.
2. A web as claimed in Claim 1 wherein the particles bear an electrostatically derived charge prior to contact with the web.
- 50 3. A web as claimed in either Claim 1 or 2 wherein other fibres are mixed with the blown fibres. 50
4. A web as claimed in any preceding Claim having wood pulp or staple textile fibres intermingled with the meltblown thermoplastic fibres.
5. A web as claimed in any one of Claim 1 to 4 in which the fibres of the meltblown thermoplastic material have a diameter of between 1 and 50 microns.
- 55 6. A web as claimed in any preceding Claim in which the blown fibres comprise microfibrils averaging less than about 10 micrometers in diameter. 55
7. A web as claimed in any preceding Claim in which the particles have a maximum dimension of between 1 and 100 microns.
8. A web as claimed in any preceding Claim having a wetting agent therein.
- 60 9. A web as claimed in any preceding Claim in which surfactant which assists in wetting of the web by a liquid to be absorbed is added to the web. 60
10. A web as claimed in any preceding Claim in which the particles are clay, kaolin, talc, calcium carbonate, sodium sulphate, sodium carbonate, aluminium oxide or calcined china clay.
11. A web as claimed in any one of Claims 1 to 9 wherein the particles are particles of organic material, e.g. sponge. 65

12. A web as claimed in any one of claims 1 to 9 wherein the particles are superabsorbent.
13. A sanitary napkin, diaper, incontinence pad or the like including a web containing substantially individual spaced particles or absorbent material as claimed in any preceding Claim.
14. A method of making a fluid retentive non-woven web comprising extruding molten polymeric material in such a way as to produce a stream of meltblown polymeric microfibres, applying an electrostatic charge to particles of absorbent material, directing the particles onto the stream of microfibres, and then forming or consolidating the fibres into a web with the particles distributed substantially individually and spaced throughout the web. 5
15. A method as claimed in Claim 14 in which the particles are blown onto the stream of fibres shortly after the fibres leave an extrusion nozzle. 10
16. A method as claimed in either claim 14 or 15 in which the particles are injected into an air stream prior to the air stream impinging on the fibres 10
17. A method as claimed in Claim 16 in which the velocity of the air stream is adjusted so that the majority of the particles are trapped by the meltblown fibres and do not pass through the fibre stream,
18. A method as claimed in Claim 17 in which the air stream has a velocity of about 6000 feet per minute (30 m/s). 15
19. A method as claimed in any one of claims 14 to 18 in which the web is hot calendered or embossed by passing it between heated patterned bonding rolls.
20. A method as claimed in Claim 19 in which the depth of the embossing member on the patterned roll is greater than the thickness of the web. 20
21. A method as claimed in either Claim 19 or 20 in which the embossing rolls are driven at different speeds.
22. A method as claimed in any of Claims 14 to 21 in which other fibres are introduced into the stream of microfibres prior to formation of the fibres into a web.
23. A method as claimed in any one of claims 14 to 22 in which a wetting agent is added to the fibres. 25
24. A method as claimed in any one of claims 14 to 23 wherein particles of superabsorbent material are directed into the stream of microfibres.
25. A fluid retentive web substantially as described herein with reference to Figures 2 and 3, 4 and 5, 6, 8 to 11 or 12 of the accompanying drawings.
26. A method of making a fluid retentive web substantially as described herein with reference to Figures 1 or 7 of the accompanying drawings. 30