



US010994918B1

(12) **United States Patent**
Seiders et al.

(10) **Patent No.:** **US 10,994,918 B1**

(45) **Date of Patent:** **May 4, 2021**

(54) **INSULATING DEVICE AND METHOD FOR FORMING INSULATING DEVICE**

(71) Applicant: **YETI Coolers, LLC**, Austin, TX (US)

(72) Inventors: **Roy Joseph Seiders**, Austin, TX (US); **Chris Keller**, Austin, TX (US); **Derek G. Sullivan**, Austin, TX (US); **Erik Steven Larson**, Austin, TX (US); **Alex Baires**, Austin, TX (US); **Andrew M. Bosway**, Austin, TX (US); **Karl Fritzsche**, Seattle, WA (US); **Laura Flores**, Austin, TX (US)

(73) Assignee: **YETI Coolers, LLC**, Austin, TX (US)

(*) Notice: Subject to any disclaimer, the term of this patent is extended or adjusted under 35 U.S.C. 154(b) by 0 days.

(21) Appl. No.: **17/118,113**

(22) Filed: **Dec. 10, 2020**

Related U.S. Application Data

(60) Continuation of application No. 16/545,008, filed on Aug. 20, 2019, which is a continuation of application (Continued)

(51) **Int. Cl.**
B65D 81/38 (2006.01)
A45C 3/00 (2006.01)
(Continued)

(52) **U.S. Cl.**
CPC **B65D 81/3897** (2013.01); **A45C 3/00** (2013.01); **A45C 3/001** (2013.01); **A45C 11/20** (2013.01);
(Continued)

(58) **Field of Classification Search**
CPC **A45C 11/20**; **A45C 13/008**; **A45C 13/02**; **A45C 13/10**; **A45C 13/30**;
(Continued)

(56) **References Cited**

U.S. PATENT DOCUMENTS

210,994 A 12/1878 Carnagy
1,512,549 A 10/1924 Labadie et al.
(Continued)

FOREIGN PATENT DOCUMENTS

AU 201614228 S 8/2016
AU 201614229 S 8/2016
(Continued)

OTHER PUBLICATIONS

United States District Court Southern District of Texas Houston Division, "Plaintiff YETI's Complaint for Patent Infringement", *YETI Coolers, LLC v. Igloo Products Corporation*, Case 4:21-cv-00505, filed Feb. 12, 2021, 98 pages.

(Continued)

Primary Examiner — Philip C Tucker
Assistant Examiner — Brian R Slawski

(74) *Attorney, Agent, or Firm* — Banner & Witcoff, Ltd.

(57) **ABSTRACT**

An insulating device can include an aperture having a waterproof closure which allows access to the chamber within the insulating device. The closure can help prevent any fluid leakage into and out of the insulating device if the insulating device is overturned or in any configuration other than upright. The closure may also prevent any fluid from permeating into the chamber if the insulating device is exposed to precipitation, other fluid, or submersed under water. This construction results in an insulating chamber that is substantially impervious to water and other liquids when the closure is sealed.

30 Claims, 51 Drawing Sheets

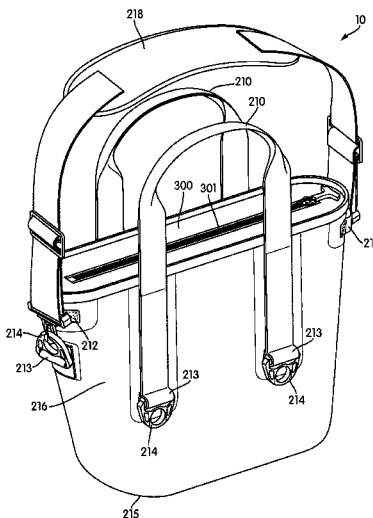

Related U.S. Application Data

(56)

References Cited

No. 15/261,407, filed on Sep. 9, 2016, now Pat. No. 10,384,855, which is a continuation-in-part of application No. 15/154,626, filed on May 13, 2016, now Pat. No. 10,029,842, which is a continuation-in-part of application No. 14/831,641, filed on Aug. 20, 2015, now Pat. No. 9,796,517, which is a division of application No. 14/479,607, filed on Sep. 8, 2014, now Pat. No. 9,139,352.

U.S. PATENT DOCUMENTS

- (60) Provisional application No. 61/937,310, filed on Feb. 7, 2014, provisional application No. 62/299,402, filed on Feb. 24, 2016, provisional application No. 62/299,421, filed on Feb. 24, 2016, provisional application No. 62/292,024, filed on Feb. 5, 2016.

(51) **Int. Cl.**

- A45C 11/20* (2006.01)
- A45C 13/00* (2006.01)
- A45C 13/10* (2006.01)
- F25D 3/08* (2006.01)
- B29C 65/00* (2006.01)
- B32B 37/14* (2006.01)
- B32B 37/18* (2006.01)
- B29C 65/02* (2006.01)
- B29C 65/62* (2006.01)
- B29C 65/56* (2006.01)
- B29C 65/72* (2006.01)
- B29C 59/02* (2006.01)

(52) **U.S. Cl.**

- CPC *A45C 13/008* (2013.01); *A45C 13/103* (2013.01); *B29C 59/02* (2013.01); *B29C 65/02* (2013.01); *B29C 65/562* (2013.01); *B29C 65/62* (2013.01); *B29C 65/72* (2013.01); *B29C 66/43* (2013.01); *B29C 66/4322* (2013.01); *B29C 66/4326* (2013.01); *B32B 37/142* (2013.01); *B32B 37/185* (2013.01); *F25D 3/08* (2013.01); *F25D 2331/801* (2013.01); *Y10T 29/49826* (2015.01); *Y10T 29/49828* (2015.01)

(58) **Field of Classification Search**

- CPC *A45C 2013/026*; *A45C 2013/303*; *A45C 3/00*; *A45C 3/001*; *A45C 7/0077*; *A45C 13/103*; *F25D 3/08*; *F25D 2331/801*; *F25D 2331/804*; *B65D 81/3848*; *B65D 81/3851*; *B65D 81/3858*; *B65D 81/3888*; *B65D 81/3897*; *B65D 25/28*; *B65D 25/2867*; *B65D 25/2873*; *B65D 39/00*; *B65D 45/00*; *B65D 45/16*; *B29C 65/02*; *B29C 65/18*; *B29C 65/56*; *B29C 65/562*; *B29C 65/62*; *B29C 65/72*; *B29C 66/1122*; *B29C 66/43*; *B29C 66/432*; *B29C 66/4322*; *B29C 66/4326*; *B29C 59/00*; *B29C 59/02*; *B32B 37/142*; *B32B 37/16*; *B32B 37/18*; *B32B 37/182*; *B32B 37/185*; *Y10T 29/49826*
- USPC 156/60, 66, 69, 70, 80, 90, 91, 92, 93, 156/196, 212, 213, 215, 217, 218, 242, 156/245, 292, 293, 294, 303.1, 308.2, 156/308.4, 309.6; 383/17, 20, 42, 92, 97, 383/110, 119; 206/545, 549; 62/457.7, 62/530

See application file for complete search history.

1,587,655	A	6/1926	Kidwell
1,949,677	A	3/1934	Crawford
2,119,621	A	6/1938	Ferrone
2,253,598	A	8/1941	Africa
2,289,254	A	7/1942	Eagles
2,429,538	A	10/1947	Wood
2,522,381	A	9/1950	Kramer
2,570,300	A	10/1951	Acton
2,575,191	A	11/1951	Seipp
2,575,893	A	11/1951	Seaman
2,633,223	A	3/1953	Zeamer
2,651,485	A	9/1953	Schutz
2,661,785	A	12/1953	Daust
2,685,385	A	8/1954	Kuss
2,808,093	A	10/1957	Gilman
2,883,041	A	4/1959	Pfeifer et al.
2,954,891	A	10/1960	Imber
2,960,136	A	11/1960	Ziff
3,031,121	A	4/1962	Chase
3,035,733	A	5/1962	Knapp
3,066,846	A	12/1962	Domigan
3,157,303	A	11/1964	Siegel
3,454,197	A	7/1969	Thompson
3,743,522	A	7/1973	Nagasawa et al.
3,801,425	A	4/1974	Cook
3,814,288	A	6/1974	Westrich
3,834,044	A	9/1974	McAusland et al.
3,905,511	A	9/1975	Groendal
4,024,731	A	5/1977	Branscum
4,125,212	A	11/1978	Courchesne
4,127,155	A	11/1978	Hydorn
4,143,695	A	3/1979	Hoehn
4,194,627	A	3/1980	Christensen
4,196,817	A	4/1980	Moser
4,197,890	A	4/1980	Simko
4,210,186	A	7/1980	Belenson
4,211,091	A	7/1980	Campbell
4,211,267	A	7/1980	Skovgaard
4,248,366	A	2/1981	Christiansen
D265,948	S	8/1982	Stark
4,344,303	A	8/1982	Kelly, Jr.
4,372,453	A	2/1983	Branscum
4,375,828	A	3/1983	Biddison
D268,879	S	5/1983	Outcalt
4,399,668	A	8/1983	Williamson
4,468,933	A	9/1984	Christopher
4,513,895	A	4/1985	Leslie
4,515,421	A	5/1985	Steffes
4,521,910	A	6/1985	Keppel et al.
4,537,313	A	8/1985	Workman
4,541,540	A	9/1985	Gretz et al.
D281,122	S	10/1985	Bomes et al.
D281,546	S	12/1985	Bradshaw
D281,646	S	12/1985	Bomes et al.
D282,602	S	2/1986	Allen
4,571,338	A	2/1986	Okonogi et al.
4,595,101	A	6/1986	Rivera
4,596,370	A	6/1986	Adkins
D284,620	S	7/1986	Calton
4,598,746	A	7/1986	Rabinowitz
4,637,063	A	1/1987	Sullivan et al.
D289,128	S	4/1987	Bradshaw
4,673,117	A	6/1987	Calton
4,679,242	A	7/1987	Brockhaus
4,708,254	A	11/1987	Byrns
4,746,028	A	5/1988	Bagg
4,759,077	A	7/1988	Leslie
4,765,476	A	8/1988	Lee
4,796,785	A	1/1989	Merritt
4,796,937	A	1/1989	Andrea
4,802,344	A	2/1989	Livingston et al.
4,802,602	A	2/1989	Evans et al.
4,805,776	A	2/1989	Namgyal et al.
4,812,054	A	3/1989	Kirkendall
4,817,769	A	4/1989	Saliba

(56)

References Cited

U.S. PATENT DOCUMENTS

4,826,060	A	5/1989	Hollingsworth	5,915,580	A	6/1999	Melk
4,841,603	A	6/1989	Ragni	5,931,583	A	8/1999	Collie
4,858,444	A	8/1989	Scott	D414,379	S	9/1999	Haberkorn
4,867,214	A	9/1989	Fuller	5,954,253	A	9/1999	Swetish
4,871,069	A	10/1989	Guimont	5,988,468	A	11/1999	Murdoch et al.
4,886,183	A	12/1989	Fleming	5,988,879	A	11/1999	Bredderman et al.
4,941,603	A	7/1990	Creamer et al.	6,019,245	A	2/2000	Foster et al.
4,984,906	A	1/1991	Little	6,027,249	A	2/2000	Bielinski
4,986,089	A	1/1991	Raab	6,029,847	A	2/2000	Mahoney, Jr. et al.
4,989,418	A	2/1991	Hewlett	6,048,099	A	4/2000	Muffett et al.
5,004,091	A	4/1991	Natho et al.	D424,417	S	5/2000	Axelsson
5,005,679	A	4/1991	Hjelle	6,059,140	A	5/2000	Hicks
5,042,664	A	8/1991	Shyr et al.	6,065,873	A	5/2000	Fowler
5,048,734	A	9/1991	Long	6,068,402	A	5/2000	Freese et al.
5,062,557	A	11/1991	Mahvi et al.	6,070,718	A	6/2000	Drabwell
5,190,376	A	3/1993	Book	6,073,796	A	6/2000	Mogil
5,216,900	A	6/1993	Jones	6,082,589	A	7/2000	Ash et al.
5,221,016	A	6/1993	Karpal	6,082,896	A	7/2000	Pulli
5,237,838	A	8/1993	Merritt-Munson	6,089,038	A	7/2000	Tattam
5,244,136	A	9/1993	Collaso	6,092,266	A	7/2000	Lee
D339,979	S	10/1993	Wehrley	6,092,661	A	7/2000	Mogil
D340,387	S	10/1993	Melk	6,105,214	A	8/2000	Press
D340,621	S	10/1993	Melk	6,113,268	A	9/2000	Thompson
D340,840	S	11/1993	Melk	6,116,045	A	9/2000	Hodosh et al.
5,269,368	A	12/1993	Schneider et al.	6,128,915	A	10/2000	Wagner
D343,992	S	2/1994	Melk	6,129,254	A	10/2000	Yu
5,297,870	A	3/1994	Weldon	6,139,188	A	10/2000	Marzano
5,313,807	A	5/1994	Owen	6,145,715	A	11/2000	Slonim
D347,971	S	6/1994	Krugman	6,149,305	A	11/2000	Fier
5,325,991	A	7/1994	Williams	D437,110	S	2/2001	Ivarson et al.
D349,428	S	8/1994	Krugman	6,193,034	B1	2/2001	Fournier
5,354,131	A	10/1994	Mogil	6,209,343	B1	4/2001	Owen
5,355,684	A	10/1994	Guice	6,220,473	B1	4/2001	Lehman et al.
5,398,848	A	3/1995	Padamsee	6,234,677	B1	5/2001	Mogil
5,400,610	A	3/1995	Macedo	6,237,776	B1	5/2001	Mogil
5,403,095	A	4/1995	Melk	6,244,458	B1	6/2001	Frysinger et al.
5,421,172	A	6/1995	Jones	6,247,328	B1	6/2001	Mogil
5,447,764	A	9/1995	Langford	6,253,570	B1	7/2001	Lustig
5,472,279	A	12/1995	Lin	6,276,579	B1	8/2001	DeLoach
5,490,396	A	2/1996	Morris	D447,632	S	9/2001	Gisser
5,509,279	A	4/1996	Brown et al.	D447,667	S	9/2001	Schneider et al.
D370,599	S	6/1996	Christopher et al.	6,286,709	B1	9/2001	Hudson
D371,051	S	6/1996	Melk	6,296,134	B1	10/2001	Cardinale
D371,052	S	6/1996	Melk	6,296,165	B1	10/2001	Mears
5,529,217	A	6/1996	Siegel	6,298,993	B1	10/2001	Kalozdi
D373,515	S	9/1996	Melk	6,336,342	B1	1/2002	Zeddies
5,553,759	A	9/1996	McMaster et al.	6,336,577	B1	1/2002	Harris et al.
5,562,228	A	10/1996	Ericson	6,347,706	B1	2/2002	D'Ambrosio
5,564,568	A	10/1996	Rankin, Sr.	6,353,215	B1	3/2002	Revels et al.
5,569,401	A	10/1996	Gilliland et al.	D455,934	S	4/2002	Culp et al.
5,595,320	A	1/1997	Aghassipour	6,363,739	B1	4/2002	Hodosh et al.
D382,771	S	8/1997	Mogil	D457,307	S	5/2002	Pukall et al.
D382,772	S	8/1997	Mogil	6,409,066	B1	6/2002	Schneider et al.
D383,360	S	9/1997	Melk	6,422,032	B1	7/2002	Greene
5,680,944	A	10/1997	Rueter	6,439,389	B1	8/2002	Mogil
5,680,958	A	10/1997	Mann et al.	D464,235	S	10/2002	Jeong
D386,310	S	11/1997	Smith	D465,134	S	11/2002	Joss
5,687,874	A	11/1997	Omori et al.	6,481,239	B2	11/2002	Hodosh et al.
D387,249	S	12/1997	Mogil	D466,291	S	12/2002	Ng
5,706,969	A	1/1998	Yamada et al.	6,495,194	B2	12/2002	Sato et al.
5,732,867	A	3/1998	Perkins et al.	6,505,479	B2	1/2003	Defelice et al.
D394,553	S	5/1998	Lin	6,511,695	B1	1/2003	Paquin et al.
D395,555	S	6/1998	Ursitti	6,513,661	B1	2/2003	Mogil
5,758,513	A	6/1998	Smith	D472,431	S	4/2003	Spence, Jr.
5,779,089	A	7/1998	West	6,554,155	B1	4/2003	Beggins
D397,273	S	8/1998	Collie	D474,649	S	5/2003	Spence, Jr.
5,816,709	A	10/1998	Demus	6,582,124	B2	6/2003	Mogil
D401,063	S	11/1998	Yamamoto et al.	D476,481	S	7/2003	Gilbert
5,842,571	A	12/1998	Rausch	6,595,687	B2	7/2003	Godshaw et al.
5,845,514	A	12/1998	Clarke et al.	D478,782	S	8/2003	Li
5,848,734	A	12/1998	Melk	6,604,649	B1	8/2003	Campi
5,857,778	A	1/1999	Elis	6,605,311	B2	8/2003	Villagran et al.
D409,376	S	5/1999	Golenz et al.	6,619,447	B1	9/2003	Garcia, III et al.
5,909,821	A	6/1999	Guridi	6,626,342	B1	9/2003	Gleason
5,913,448	A	6/1999	Mann et al.	6,629,430	B2	10/2003	Mills et al.
				D482,241	S	11/2003	Tyler
				6,652,933	B2	11/2003	Hall
				6,655,543	B2	12/2003	Beuke
				D485,131	S	1/2004	Lanman et al.

(56)

References Cited

U.S. PATENT DOCUMENTS

D485,732	S	1/2004	Lanman et al.	D619,854	S	7/2010	Koehler et al.
D486,038	S	2/2004	Lanman et al.	D619,855	S	7/2010	Koehler et al.
6,688,470	B2	2/2004	Dege et al.	7,757,878	B2	7/2010	Mogil et al.
6,729,758	B1	5/2004	Carter	D620,707	S	8/2010	Mogil
D492,160	S	6/2004	Lanman et al.	D620,708	S	8/2010	Sanz
D497,518	S	10/2004	Bellofatto, Jr. et al.	7,775,388	B2	8/2010	Murrer, III
6,799,693	B2	10/2004	Meza	7,784,759	B2	8/2010	Farrell
D498,924	S	11/2004	Karl	7,791,003	B2	9/2010	Lockhart et al.
D501,600	S	2/2005	Guyon	7,811,620	B2	10/2010	Merrill et al.
D502,599	S	3/2005	Cabana et al.	7,815,069	B1	10/2010	Bellofatto et al.
D503,279	S	3/2005	Smith	D626,329	S	11/2010	Chapelier
6,874,356	B2	4/2005	Komfeldt et al.	D627,199	S	11/2010	Pruchnicki
D506,645	S	6/2005	Bellofatto, Jr. et al.	7,841,207	B2	11/2010	Mogil et al.
6,925,834	B2	8/2005	Fuchs	D629,612	S	12/2010	Weldon
D512,274	S	12/2005	Cabey	7,874,177	B2	1/2011	Azamy
D515,362	S	2/2006	Chan	7,886,936	B2	2/2011	Helline
D516,099	S	2/2006	Maruyama	7,900,816	B2	3/2011	Kastanek et al.
D516,870	S	3/2006	Martinez et al.	D638,220	S	5/2011	Chu et al.
D517,801	S	3/2006	Woo	D642,870	S	8/2011	Whitlock et al.
D520,306	S	5/2006	Peterson	7,988,006	B2	8/2011	Mogil et al.
D522,811	S	6/2006	Martinez et al.	D645,662	S	9/2011	Perez
D523,243	S	6/2006	Nashmy	8,016,090	B2	9/2011	McCoy et al.
D527,226	S	8/2006	Maldonado	8,043,004	B2	10/2011	Mogil
D530,089	S	10/2006	Silverman	D648,532	S	11/2011	Sosnovsky
7,153,025	B1	12/2006	Jackson et al.	8,061,159	B2	11/2011	Mogil et al.
D534,352	S	1/2007	Delafontaine	D650,169	S	12/2011	Klifa
D534,771	S	1/2007	Zorn	8,079,451	B2	12/2011	Rothschild et al.
D535,099	S	1/2007	Johansson et al.	8,096,442	B2	1/2012	Ramundi
D535,820	S	1/2007	Kamiya	D662,316	S	6/2012	Nitkin
7,160,028	B1	1/2007	Linday	8,191,747	B2	6/2012	Pruchnicki
7,162,890	B2	1/2007	Mogil et al.	D664,261	S	7/2012	Kravitz et al.
D539,033	S	3/2007	Cassegrain	8,209,995	B2	7/2012	Kieling et al.
D540,037	S	4/2007	Newson	D666,896	S	9/2012	Pinholster, Jr. et al.
7,201,285	B2	4/2007	Beggins	D667,043	S	9/2012	Couch, III
7,207,716	B2	4/2007	Buchanan et al.	8,281,950	B2	10/2012	Potts et al.
7,219,814	B2	5/2007	Lown et al.	8,292,119	B2	10/2012	Kenneally
7,240,513	B1	7/2007	Conforti	8,302,749	B2	11/2012	Melmon et al.
D547,941	S	8/2007	Lucena	8,327,659	B2	12/2012	Winkler et al.
D548,459	S	8/2007	Harvey	D673,363	S	1/2013	Crandall
D550,448	S	9/2007	Boje et al.	D674,246	S	1/2013	Scott et al.
7,264,134	B2	9/2007	Tulp	D674,664	S	1/2013	Collie
D557,667	S	12/2007	Kawamura et al.	8,424,319	B2	4/2013	Whewell, Jr.
7,302,810	B2	12/2007	McCrorry	8,424,713	B2	4/2013	Bolland
D560,102	S	1/2008	Sumter	D682,635	S	5/2013	Boroski
7,313,927	B2	1/2008	Barker	8,453,899	B1	6/2013	Calkin
7,344,028	B2	3/2008	Hanson	D686,412	S	7/2013	Guichot
D566,484	S	4/2008	George	8,474,640	B2	7/2013	Armstrong
7,353,952	B2	4/2008	Swartz et al.	8,516,848	B2	8/2013	White et al.
D570,603	S	6/2008	Wu et al.	8,544,678	B1	10/2013	Hughes
D573,422	S	7/2008	Tagliati et al.	8,573,002	B2	11/2013	Ledoux et al.
D574,667	S	8/2008	Grabijas, III et al.	D695,568	S	12/2013	Hayes
D578,401	S	10/2008	Perry et al.	8,622,235	B2	1/2014	Suchecki
D582,151	S	12/2008	Gonzalez	D699,940	S	2/2014	Robert
D583,152	S	12/2008	Keeney	D699,941	S	2/2014	Robert
7,481,065	B2	1/2009	Krieger	D703,946	S	5/2014	Tweedie
7,527,430	B2	5/2009	Suskind	8,720,739	B2	5/2014	Bollis
D598,194	S	8/2009	Turvey et al.	8,777,045	B2	7/2014	Mitchell et al.
D599,550	S	9/2009	Turvey et al.	D710,085	S	8/2014	Szewczyk
7,597,478	B2	10/2009	Pruchnicki et al.	D711,096	S	8/2014	Hanna
D603,606	S	11/2009	Wang	D712,555	S	9/2014	Berg
7,634,919	B2	12/2009	Bernhard, Jr. et al.	8,827,109	B1	9/2014	Sheehan
D607,697	S	1/2010	Whitlock et al.	8,844,756	B2	9/2014	Beyburg
D608,095	S	1/2010	Turvey et al.	D715,544	S	10/2014	Levine
D608,096	S	1/2010	Noble	8,857,654	B2	10/2014	Mogil et al.
D608,159	S	1/2010	Whitlock et al.	D717,041	S	11/2014	Pulliam
D610,795	S	3/2010	Dejadon	8,875,964	B1	11/2014	Vanderberg
D611,706	S	3/2010	Angles et al.	8,893,940	B2	11/2014	Green et al.
D612,605	S	3/2010	Turvey et al.	D718,931	S	12/2014	Brundl
7,669,436	B2	3/2010	Mogil et al.	D719,303	S	12/2014	Anderson
7,677,406	B2	3/2010	Maxson	8,899,071	B2	12/2014	Mogil et al.
7,682,080	B2	3/2010	Mogil	D725,908	S	4/2015	Zwetzig
D617,560	S	6/2010	Wu	D728,942	S	5/2015	Byham
7,730,739	B2	6/2010	Fuchs	D732,295	S	6/2015	Aafjes
D618,966	S	7/2010	Koehler et al.	D732,348	S	6/2015	Seiders et al.
D619,423	S	7/2010	Koehler et al.	D732,349	S	6/2015	Seiders et al.
				D732,350	S	6/2015	Seiders et al.
				D732,899	S	6/2015	Seiders et al.
				D734,643	S	7/2015	Boroski
				D734,992	S	7/2015	Boroski

(56)

References Cited

U.S. PATENT DOCUMENTS

9,084,463	B2	7/2015	Merrill	9,901,153	B2	2/2018	Nash
D738,108	S	9/2015	Adler et al.	D811,746	S	3/2018	Seiders et al.
D739,654	S	9/2015	Brouard	D813,539	S	3/2018	Van Assche
9,139,352	B2	9/2015	Seiders et al.	D814,879	S	4/2018	Larson et al.
9,146,051	B2	9/2015	Kamin et al.	D815,496	S	4/2018	Larson et al.
D744,786	S	12/2015	Bagwell	9,943,150	B2	4/2018	Morrow
D747,104	S	1/2016	Ford	D817,106	S	5/2018	Larson et al.
9,226,558	B2	1/2016	Armstrong	D817,107	S	5/2018	Larson et al.
D749,653	S	2/2016	Carnes	D819,966	S	6/2018	Yu
D750,140	S	2/2016	Cross	D819,967	S	6/2018	Carter et al.
9,254,022	B2	2/2016	Meldeau et al.	D821,825	S	7/2018	Sullivan et al.
9,254,023	B2	2/2016	Su et al.	D822,987	S	7/2018	Seiders et al.
9,265,318	B1	2/2016	Williams et al.	D822,997	S	7/2018	Seiders et al.
D752,347	S	3/2016	Seiders et al.	D823,601	S	7/2018	Seiders et al.
9,271,553	B2	3/2016	Ponx	D823,602	S	7/2018	Seiders et al.
9,272,475	B2	3/2016	Ranade et al.	10,010,162	B1	7/2018	Woods et al.
9,290,313	B2	3/2016	De Lesseux et al.	10,029,842	B2	7/2018	Seiders et al.
D752,860	S	4/2016	Barilaro et al.	D824,660	S	8/2018	Ross
D756,109	S	5/2016	Hayashi	D824,666	S	8/2018	Carter et al.
D756,638	S	5/2016	Frisoni	D824,671	S	8/2018	Pennington
9,366,467	B2	6/2016	Kiedaisch et al.	D824,731	S	8/2018	Sullivan et al.
9,375,061	B2	6/2016	Mosee	D827,299	S	9/2018	Vickery
D760,494	S	7/2016	Harvey-Pankey	D828,112	S	9/2018	Furieux et al.
D761,561	S	7/2016	Cheng	D828,728	S	9/2018	Jacobsen
D763,570	S	8/2016	Potts	D829,244	S	9/2018	Sullivan et al.
D764,791	S	8/2016	Patel	D830,048	S	10/2018	McQueeney
D764,873	S	8/2016	Collie	D830,132	S	10/2018	Sullivan et al.
9,408,445	B2	8/2016	Mogil et al.	D830,133	S	10/2018	Sullivan et al.
D765,395	S	9/2016	Sanz	D830,134	S	10/2018	Sullivan et al.
D765,967	S	9/2016	Boroski	D832,653	S	11/2018	Waskow et al.
D766,571	S	9/2016	Boroski	10,138,048	B2	11/2018	Mitchell et al.
D768,981	S	10/2016	Kliot	D834,817	S	12/2018	Hoppe et al.
D768,987	S	10/2016	Blumenfeld	D834,895	S	12/2018	Triska et al.
D770,761	S	11/2016	Deioma et al.	D835,473	S	12/2018	Jacobsen
D770,763	S	11/2016	Joo et al.	D835,949	S	12/2018	Triska et al.
D771,372	S	11/2016	Kelly et al.	D835,950	S	12/2018	Jacobsen
D772,562	S	11/2016	Petre	10,143,282	B2	12/2018	Seiders et al.
9,545,134	B1	1/2017	Tan	D836,996	S	1/2019	Jacobsen
D778,045	S	2/2017	Ruddis	D836,997	S	1/2019	Jacobsen
D782,820	S	4/2017	Thompson	D836,998	S	1/2019	Jacobsen
D784,010	S	4/2017	Dumas	D836,999	S	1/2019	Jacobsen
D785,325	S	5/2017	Samrelius et al.	D837,000	S	1/2019	Jacobsen
D786,559	S	5/2017	Seiders et al.	D837,001	S	1/2019	Jacobsen
D786,560	S	5/2017	Seiders et al.	D838,978	S	1/2019	Lee
D786,561	S	5/2017	Seiders et al.	D839,682	S	2/2019	Jacobsen
D786,562	S	5/2017	Seiders et al.	D840,194	S	2/2019	Furieux et al.
D787,187	S	5/2017	Seiders et al.	D840,689	S	2/2019	Seiders et al.
D789,080	S	6/2017	Caffagni	D840,761	S	2/2019	Seiders et al.
D792,167	S	7/2017	Bradley	D840,762	S	2/2019	Seiders et al.
D792,486	S	7/2017	Li et al.	D840,763	S	2/2019	Seiders et al.
D793,089	S	8/2017	Jackson	D840,764	S	2/2019	Seiders et al.
D796,185	S	9/2017	Masten	D841,325	S	2/2019	Buynar
D797,454	S	9/2017	Seiders et al.	D844,975	S	4/2019	Munie et al.
D797,455	S	9/2017	Seiders et al.	D844,976	S	4/2019	Munie et al.
D798,670	S	10/2017	Seiders et al.	D844,977	S	4/2019	Munie et al.
D799,276	S	10/2017	Seiders et al.	D844,978	S	4/2019	Munie et al.
D799,277	S	10/2017	Seiders et al.	D844,979	S	4/2019	Munie et al.
D799,823	S	10/2017	Schartle	D844,992	S	4/2019	Seiders et al.
D799,905	S	10/2017	Seiders et al.	D845,625	S	4/2019	Barlier
D800,443	S	10/2017	Burton et al.	D846,275	S	4/2019	Barlier
D800,444	S	10/2017	Burton et al.	D847,500	S	5/2019	Lagerfeld
D801,123	S	10/2017	Seiders et al.	D848,219	S	5/2019	Munie et al.
9,796,517	B2	10/2017	Seiders et al.	D848,220	S	5/2019	Munie et al.
D802,028	S	11/2017	Li	D848,221	S	5/2019	Munie et al.
D802,029	S	11/2017	Li	D848,222	S	5/2019	Munie et al.
D802,373	S	11/2017	Seiders et al.	D848,223	S	5/2019	Munie et al.
D802,630	S	11/2017	Li et al.	D848,798	S	5/2019	Munie et al.
9,809,376	B2	11/2017	Mitchell et al.	D849,486	S	5/2019	Munie et al.
D805,851	S	12/2017	Sullivan et al.	10,279,980	B2	5/2019	James, Jr.
D808,173	S	1/2018	Seiders et al.	10,322,867	B2	6/2019	Furieux et al.
D808,175	S	1/2018	Seiders et al.	10,384,855	B2	8/2019	Seiders et al.
D808,655	S	1/2018	Seiders et al.	D859,934	S	9/2019	Seiders et al.
D808,730	S	1/2018	Sullivan et al.	D862,177	S	10/2019	Seiders et al.
D809,869	S	2/2018	Seiders et al.	D862,528	S	10/2019	Sullivan et al.
D811,082	S	2/2018	Lehan	D867,823	S	11/2019	Jacobsen
				D868,544	S	12/2019	Lin et al.
				D880,254	S	4/2020	Jacobsen
				D886,537	S	6/2020	Jacobsen
				D886,538	S	6/2020	Jacobsen

(56)

References Cited

U.S. PATENT DOCUMENTS

D886,539	S	6/2020	Jacobsen	2009/0317514	A1	12/2009	Sizer
D894,692	S	9/2020	Herold	2010/0047423	A1	2/2010	Kruesemann et al.
D896,039	S	9/2020	Seiders et al.	2010/0059199	A1	3/2010	Court
D896,591	S	9/2020	Seiders et al.	2010/0075006	A1	3/2010	Semenza
D897,780	S	10/2020	Seiders et al.	2010/0108694	A1	5/2010	Sedlbauer et al.
D899,197	S	10/2020	Seiders et al.	2010/0136203	A1	6/2010	Sakata et al.
D899,865	S	10/2020	Shi	2010/0143567	A1	6/2010	Ye et al.
D904,830	S	12/2020	Meda et al.	2010/0224660	A1	9/2010	Gleason
2002/0012480	A1	1/2002	Konno	2010/0269311	A1	10/2010	Jacobsen
2002/0197369	A1	12/2002	Modler	2010/0284631	A1	11/2010	Lee
2003/0070447	A1	4/2003	Tanaka	2010/0284634	A1	11/2010	Hadley
2003/0080133	A1	5/2003	Butler	2011/0003975	A1	1/2011	Arase et al.
2003/0106895	A1	6/2003	Kalal	2011/0005042	A1	1/2011	Thomas et al.
2003/0136702	A1	7/2003	Redzisz et al.	2011/0005739	A1	1/2011	Finney et al.
2003/0149461	A1	8/2003	Johnson	2011/0030415	A1	2/2011	Breyburg et al.
2003/0175394	A1	9/2003	Modler	2011/0097442	A1	4/2011	Harju et al.
2004/0004111	A1	1/2004	Cardinale	2011/0108562	A1	5/2011	Lyons
2004/0028296	A1	2/2004	Meli	2011/0167863	A1	7/2011	Herrbold
2004/0035143	A1	2/2004	Mogil	2011/0182532	A1	7/2011	Baltus
2004/0074936	A1	4/2004	McDonald	2011/0191933	A1	8/2011	Gregory et al.
2004/0094589	A1	5/2004	Fricano	2011/0284601	A1	11/2011	Pullin
2004/0136621	A1	7/2004	Mogil	2011/0311166	A1	12/2011	Pascua
2004/0144783	A1	7/2004	Anderson et al.	2012/0106130	A1	5/2012	Beaudette
2004/0149600	A1	8/2004	Wolter et al.	2012/0137637	A1	6/2012	Gillis
2004/0164084	A1	8/2004	Cooper	2012/0180184	A1	7/2012	Crye
2004/0237266	A1	12/2004	Wang	2012/0181211	A1	7/2012	Charlebois
2005/0016895	A1	1/2005	Glenn	2012/0187138	A1	7/2012	Vasquez et al.
2005/0034947	A1	2/2005	Nykoluk	2012/0261445	A1	10/2012	Demskey
2005/0045520	A1	3/2005	Johnson	2012/0294550	A1	11/2012	Hassman et al.
2005/0045521	A1	3/2005	Johnson et al.	2012/0311828	A1	12/2012	Nir
2005/0056669	A1	3/2005	Lavelle	2013/0014355	A1	1/2013	Lee
2005/0072181	A1	4/2005	Mogil et al.	2013/0043285	A1	2/2013	Cordray
2005/0133399	A1	6/2005	Fidrych	2013/0174600	A1	7/2013	Sarcinella
2005/0183446	A1	8/2005	Fuchs	2013/0200083	A1	8/2013	Cunningham
2005/0196510	A1	9/2005	Walters	2013/0216158	A1	8/2013	Meldeau et al.
2005/0262871	A1	12/2005	Bailey-Weston	2013/0264350	A1	10/2013	Handlon et al.
2005/0263528	A1	12/2005	Maldonado et al.	2013/0294712	A1	11/2013	Seuk
2005/0279124	A1	12/2005	Maldonado	2013/0341338	A1	12/2013	Mitchell et al.
2006/0007266	A1	1/2006	Silverbrook	2014/0023295	A1	1/2014	Wagner
2006/0010660	A1	1/2006	Stenhall	2014/0034543	A1	2/2014	Grubstein
2006/0021376	A1	2/2006	Scroggs	2014/0151172	A1	6/2014	Diaz
2006/0102497	A1	5/2006	Wulf	2014/0226920	A1	8/2014	Passavia
2006/0151533	A1	7/2006	Simunovic et al.	2014/0248003	A1	9/2014	Mogil et al.
2006/0201979	A1	9/2006	Achilles	2014/0254956	A1	9/2014	Buell, III
2006/0239593	A1	10/2006	Fidrych	2014/0270590	A1	9/2014	Ostroy
2006/0240159	A1	10/2006	Cash et al.	2014/0304954	A1	10/2014	La Rocca et al.
2006/0248902	A1	11/2006	Hunnell	2014/0359978	A1	12/2014	Wang
2007/0012593	A1	1/2007	Kitchens et al.	2014/0366336	A1	12/2014	Chung
2007/0148305	A1	6/2007	Sherwood et al.	2015/0008242	A1	1/2015	Kpabar, Jr.
2007/0148307	A1	6/2007	Sherwood et al.	2015/0114024	A1	4/2015	Grepper
2007/0164063	A1	7/2007	Concepcion	2015/0136796	A1	5/2015	Muehlhauser
2007/0217187	A1	9/2007	Blakely et al.	2015/0143672	A1	5/2015	Konaka et al.
2007/0221693	A1	9/2007	Moore	2015/0164153	A1	6/2015	Tsai
2007/0237432	A1	10/2007	Mogil	2015/0175338	A1	6/2015	Culp et al.
2007/0261977	A1	11/2007	Sakai	2015/0225164	A1	8/2015	Seiders et al.
2007/0274613	A1	11/2007	Pruchnicki et al.	2015/0335202	A1	11/2015	Wisner et al.
2007/0290816	A1	12/2007	Bedard	2015/0353263	A1	12/2015	Seiders et al.
2008/0038424	A1	2/2008	Krusemann	2016/0066817	A1	3/2016	Hannes
2008/0073364	A1	3/2008	Simmons	2016/0095405	A1	4/2016	Wang
2008/0105282	A1	5/2008	Fernholz et al.	2016/0100661	A1	4/2016	Redzisz et al.
2008/0128421	A1	6/2008	Ulbrand et al.	2016/0101924	A1	4/2016	Mitchell et al.
2008/0160149	A1	7/2008	Nasrallah et al.	2016/0107816	A1	4/2016	Larpenteur et al.
2008/0164265	A1	7/2008	Conforti	2016/0198812	A1	7/2016	Tan
2008/0178865	A1	7/2008	Retterer	2016/0198901	A1	7/2016	De Lesseux et al.
2008/0189918	A1	8/2008	Kusayama	2016/0236849	A1	8/2016	Seiders et al.
2008/0245096	A1	10/2008	Hanson et al.	2016/0255943	A1	9/2016	Houston et al.
2008/0260303	A1	10/2008	De Lesseux et al.	2016/0257479	A1	9/2016	Seiders et al.
2008/0264925	A1	10/2008	Lockhart et al.	2016/0338462	A1	11/2016	Hayashi
2008/0305235	A1	12/2008	Gao et al.	2016/0338908	A1	11/2016	Rice et al.
2009/0052809	A1	2/2009	Sampson	2016/0355319	A1	12/2016	Stephens
2009/0080808	A1	3/2009	Hagen	2017/0036844	A1	2/2017	Seiders et al.
2009/0095757	A1	4/2009	Ramundi	2017/0071304	A1	3/2017	Wang
2009/0242619	A1	10/2009	Blomberg	2017/0071305	A1	3/2017	Wang
2009/0280229	A1	11/2009	Constantine et al.	2017/0099920	A1	4/2017	Bailey
2009/0311378	A1	12/2009	Wilaschin et al.	2017/0137205	A1	5/2017	Graf et al.
				2017/0208907	A1	7/2017	Chung
				2017/0210542	A1	7/2017	Seiders et al.
				2017/0225872	A1	8/2017	Collie
				2017/0265604	A1	9/2017	Martinson et al.

(56)

References Cited

U.S. PATENT DOCUMENTS

2018/0016084 A1 1/2018 Xia et al.
 2018/0078008 A1 3/2018 Sturm
 2018/0098607 A1 4/2018 Seiders et al.
 2018/0162626 A1 6/2018 Munie et al.
 2018/0235324 A1 8/2018 Gordon
 2018/0242701 A1 8/2018 Seiders et al.
 2018/0263346 A1 9/2018 Stephens
 2018/0279733 A1 10/2018 Young et al.
 2018/0317620 A1 11/2018 Larson et al.
 2018/0360172 A1 12/2018 Chou
 2019/0037976 A1 2/2019 Cheng
 2019/0133281 A1 5/2019 Munie et al.
 2019/0142117 A1 5/2019 Myerscough et al.
 2019/0170422 A1 6/2019 Dexter
 2020/0029658 A1 1/2020 Zhang
 2020/0037711 A1 2/2020 Kayahara et al.

FOREIGN PATENT DOCUMENTS

AU 201614230 S 8/2016
 BE 1015808 A6 9/2005
 CA 2243820 A1 1/2000
 CA 89737 A 6/2000
 CA 2300014 A1 8/2001
 CA 2327764 A1 6/2002
 CA 2433251 A1 12/2004
 CA 2483802 A1 4/2006
 CA 2498796 A1 9/2006
 CA 2499291 A1 9/2006
 CA 2503473 A1 10/2006
 CA 2548064 A1 11/2007
 CA 2549327 A1 11/2007
 CA 2633223 A1 12/2009
 CA 2782668 A1 12/2013
 CA 163677 A 6/2016
 CN 2125339 U 12/1992
 CN 2188899 Y 2/1995
 CN 201062136 Y 5/2008
 CN 101500900 A 8/2009
 CN 201351017 Y 11/2009
 CN 201948200 U 8/2011
 CN 101500900 B 9/2011
 CN 301956022 6/2012
 CN 102717977 A 10/2012
 CN 202619972 U 12/2012
 CN 202635944 U 1/2013
 CN 202807322 U 3/2013
 CN 202959175 U 6/2013
 CN 103385657 A 11/2013
 CN 302623771 11/2013
 CN 302623775 11/2013
 CN 302746176 2/2014
 CN 302769710 3/2014
 CN 103763994 A 4/2014
 CN 104085612 A 10/2014
 CN 302956550 10/2014
 CN 204120419 U 1/2015
 CN 303100086 2/2015
 CN 303342902 8/2015
 CN 204763894 U 11/2015
 CN 303459386 11/2015
 CN 105520325 A 4/2016
 CN 304259949 8/2017
 CN 304373532 11/2017
 CN 304906858 11/2018
 CN 208259266 U 12/2018
 DE 3539626 A1 5/1987
 DE 20002689 U1 8/2000
 DE 202011050174 U1 7/2011
 DE 202013101115 U1 3/2013
 EP 0037545 A2 10/1981
 EP 0082131 A2 6/1983
 EP 85534 A1 8/1983
 EP 0158634 A1 10/1985
 EP 0174159 A2 3/1986

EP 0238932 A1 9/1987
 EP 002182642-0001 2/2013
 EP 002322552-0001 10/2013
 EP 002745190-0001 9/2015
 EP 004100048-0001 9/2017
 EP 004100048-0002 9/2017
 EP 003328608-0009 2/2019
 FR 1269009 A 8/1961
 FR 2440886 A1 6/1980
 GB 191415563 A 6/1915
 GB 1600133 A 10/1981
 GB 2249717 A 5/1992
 GB 2023549 A 9/1992
 GB 2335972 A 10/1999
 GB 3004135 9/2002
 GB 3006367 10/2002
 GB 6028395 2/2018
 JP 11051532 2/1999
 JP 3275477 B2 4/2002
 JP D1160335 12/2002
 JP 2003026258 A 1/2003
 JP D1213384 8/2004
 JP D1242111 6/2005
 JP 2010023926 A 2/2010
 JP D1445624 7/2012
 JP D1469606 5/2013
 JP D1531414 8/2015
 JP D1543325 8/2015
 KR 20020027739 A 4/2002
 KR 20040092730 A 11/2004
 KR 101282512 B1 7/2013
 KR 300778570.0000 1/2015
 KR 300808669.0000 8/2015
 KR 300835242.0000 1/2016
 KR 300853718.0000 5/2016
 KR 300968949.0000 8/2018
 KR 300978269.0000 10/2018
 WO 9524146 A2 9/1995
 WO 9812954 A1 4/1998
 WO 02058500 A1 8/2002
 WO 2006007266 A2 1/2006
 WO 2006058538 A1 6/2006
 WO 2007016092 A2 2/2007
 WO 2010106296 A2 9/2010
 WO 2010120199 A1 10/2010
 WO 2012003543 A1 1/2012
 WO 2014033450 A1 3/2014
 WO 2014066026 A1 5/2014
 WO 2016066817 A1 5/2016
 WO 17136754 A1 8/2017
 WO 17197230 A1 11/2017
 WO 2018165426 A1 9/2018
 WO 19135922 A1 7/2019

OTHER PUBLICATIONS

Jan. 20, 2021—(CN) Third Office Action—App. No. 201780020473. X.

United States District Court Western District of Texas, Austin Division, “Complaint for Damages and Injunctive Relief,” *YETI Coolers, LLC v. Olympia Tools International, Inc. d/b/a Coho Outdoors*, Case 1:19-cv-00912, Document 1, Filed Sep. 16, 2019, 235 pages.

United States District Court Western District of Texas, Austin Division, “Defendant Olympia Tools International, Inc. d/b/a Coho Outdoors’ Answer and Counterclaims to Plaintiff’s Original Complaint,” *YETI Coolers, LLC v. Olympia Tools International, Inc. d/b/a Coho Outdoors*, Case 1:19-cv-00912, filed Dec. 18, 2019, 48 pages.

Translation of FR 1269009A, Jackson, Jr., Jun. 26, 1961, p. 1, Fig. 2 (Year: 1961).

Mar. 20, 2020—(CN) Office Action—App. No. 201680076714.8.

Jul. 14, 2020—(CA) Office Action—App. No. 3024101.

First Look: YETI Hopper Flip Soft Cooler Review | GearJunkie which was published on the website; <https://gearjunkie.com/review-yeti-hopper-flip-12-soft-cooler> on Jul. 12, 2016.

(56) **References Cited**

OTHER PUBLICATIONS

- YETI Flip Review—YouTube vich was published on the website <https://www.youtube.com/watch?v=97Vdb3lazdw> on Sep. 8, 2016.
- Jul. 2, 2020—(AU) First Office Action—App. No. 201712263.
- Jul. 2, 2020—(AU) First Office Action—App. No. 201712262.
- Jul. 2, 2020—(AU) First Office Action—App. No. 201712264.
- Jul. 2, 2020—(AU) First Office Action—App. No. 201712265.
- Jul. 31, 2020—(CN) Second Office Action (with English Translation)—App. No. 201780020473.X.
- Aug. 17, 2020—(CN) Third Office Action (with English Translation)—App. No. 201680076714.8.
- Stopper Dry Bag, <http://www.seatosummit.com/products/display/181>, published date unknown, but prior to the filing date of the present application, Sea to Summit, United States.
- Icemule Classic Cooler—Large (20L), <http://www.icemulecooler.com/icemule-classic-cooler-large-20l/>, published date unknown, but prior to the filed of the present application, ICEMULE, United States.
- Devonbuy.com: Thule Gauntlet 13" MacBook Pro Attaché. Published on Jul. 28, 2014. Retrieved from the internet at <http://www.devonbuy.com/thule-gauntlet-13-macbook-pro-attache/>, Feb. 24, 2016. 9 pages.
- United States District Court for the Western District of Texas, Austin Division, “Defendants’ Answer and Counterclaims to YETI’s Complaint,” *YETI Coolers, LLC*, vs. *RTIC Soft Sided Coolers, LLC, RTIC Coolers, LLC, RTIC Web Services, LLC, and Corporate Support and Fulfillment, LLC*, Case 1:16-cv-00909-RP, Document 11, Filed Aug. 18, 2016, 44 pages.
- United States District Court Western District of Texas, Austin Division, “Complaint,” *YETI Coolers, LLC*, v. *RTIC Soft Side Coolers, RTIC Coolers, LLC, RTIC Web Services, LLC, and Corporate Support and Fulfillment, LLC*, Case 1:16-cv-00909, Document 1, Filed Jul. 27, 2016, 66 pages.
- United States District Court Western District of Texas, Austin Division, “Complaint for Damages and Injunctive Relief,” *YETI Coolers, LLC* v. *Jennifer Leverage Bootz Evans d/b/a Bling and Burlap Buy In’s and Blanks*, Case 1:15-cv-00995, Document 1, Filed Nov. 2, 2015, 128 pages.
- United States District Court Western District of Texas, Austin Division, “Order,” *YETI Coolers, LLC* v. *Jennifer Leverage Bootz Evans d/b/a Bling and Burlap Buy In’s and Blanks*, Case 1:15-cv-00995-RP, Document 18, Filed Apr. 18, 2016, 1 page.
- United States District Court Western District of Texas, Austin Division, “Defendant’s Reply in Support of Their Rule 12 (B)(6) Motion to Dismiss for Failure to State a Claim” *YETI Coolers, LLC* v. *RTIC Soft Sided Coolers, LLC, RTIC Coolers, LLC, RTIC Web Services, LLC, and Corporate Support and Fulfillment, LLC*, Case 1:16-cv-00909-RP, Document 15, Filed Sep. 8, 2016, 13 pages.
- United States District Court Western District of Texas, Austin Division, “YETI’s Answer to RTIC’s Counterclaims,” *YETI Coolers, LLC* v. *RTIC Soft Sided Coolers, LLC, RTIC Coolers, LLC, RTIC Web Services, LLC, and Corporate Support and Fulfillment, LLC*, Case 1:16-cv-00909-RP, Document 14, Filed Sep. 2, 2016, 16 pages.
- United States District Court Western District of Texas, Austin Division, “YETI’s Opposition to RTIC’s Motion to Dismiss,” *YETI Coolers, LLC* v. *RTIC Soft Sided Coolers, LLC, RTIC Coolers, LLC, RTIC Web Services, LLC, and Corporate Support and Fulfillment, LLC*, Case 1:16-cv-00909-RP, Document 13, Filed Sep. 1, 2016, 17 pages.
- United States District Court for the Western District of Texas, Austin Division, “Defendants’ Rule 12(B)(6) Motion to Dismiss for Failure to State a Claim,” *YETI Coolers, LLC*, vs. *RTIC Soft Sided Coolers, LLC, RTIC Coolers, LLC, RTIC Web Services, LLC, and Corporate Support and Fulfillment, LLC*, Case 1:16-cv-00909-RP, Document 10, Filed Aug. 18, 2016, 12 pages.
- United States District Court for the Western District of Texas, Austin Division, “Joint Rule 26(f) Report and Discovery Plan,” *YETI Coolers, LLC*, vs. *RTIC Soft Sided Coolers, LLC, RTIC Coolers, LLC, RTIC Web Services, LLC, and Corporate Support and Fulfillment, LLC*, Case 1:16-cv-00909-RP, Document 19, Filed Oct. 11, 2016, 9 pages.
- Petition for Inter Partes Review of U.S. Pat. No. 9,139,352, filed on Dec. 13, 2016, 1616 pages.
- TheGadgeteer.com: Tom Bihn Camera I-O Bag Review. Published Jul. 9, 2012. Retrieved from the internet at <http://the-gadgeteer.com/2012/07/09/tom-bihn-camera-i-o-bag-review/>, Jan. 11, 2016. 7 pages.
- YouTube.com: Patagonia Black Hole Duffel 60L. Published Aug. 26, 2013. Retrieved from the internet at <https://www.youtube.com/watch?v=W-PWEmZmVv8>, Dec. 19, 2016. 1 page.
- Youtube, “YETI Hopper Cooler at ICAST 2014”, Uploaded by user TackleDirect on Jul. 17, 2014, Accessed Jan. 31, 2017. (<https://www.youtube.com/watch?v=A2rKRdyZcZ4>).
- Ebags, Picnic Pack Picnic Pack Large Insulated Cooler Tote, First reviewed on Jul. 20, 2016. Accessed Feb. 7, 2017. (<http://www.ebags.com/product/picnic-pack/picnic-pack-large-insulated-cooler-tote/313704?productid=10428840>).
- United States Patent and Trademark Office Before the Patent Trial and Appeal Board, Decisions Joint Motions to Terminate Inter Partes Review, Entered Mar. 22, 2017—(4 pgs).
- Jan. 31, 2017—(WO) International Search Report and Written Opinion—App. PCT/US2016/060135.
- Mar. 27, 2017—(WO) International Search Report and Written Opinion—App PCT/US2017/016552.
- May 8, 2017—U.S. Non-Final Office Action—U.S. Appl. No. 15/154,626.
- May 22, 2015—U.S. Non-Final Office Action—U.S. Appl. No. 14/479,607.
- United States District Court Western District of Texas Austin Division, “Complaint,” *YETI Coolers, LLC* v. *Glacier Coolers, LLC, and Tecomate Holdings, LLC*, Case 1:17-cv-00586, Document 1, filed Jun. 15, 2017, 161 pages.
- May 30, 2017—(WO) ISR—App. No. PCT/US17/32351.
- May 30, 2017—(WO) Written Opinion—App. No. PCT/US17/32351.
- Vimeo, “Cleaning Your YETI Hopper” uploaded by user YETI Coolers on Nov. 4, 2014, Accessed Sep. 27, 2017. (<https://vimeo.com/110890075>).
- Sep. 13, 2017—U.S. Final Office Action—U.S. Appl. No. 15/137,838.
- Nov. 24, 2017—U.S. Final Office Action—U.S. Appl. No. 15/154,626.
- Good Housekeeping, “Lands’ End Zip Top Cooler Tote #433786”, Reviewed on Apr. 2014, Accessed Nov. 18, 2017. (<http://www.goodhousekeeping.com/travel-products/food-cooler-reviews/a33270/lands-end-zip-top-cooler-tote-433786/>).
- Home Shopping Network, “Built New York Large Welded Cooler Bag”, Accessed Nov. 18, 2017. (<https://www.hsn.com/products/built-new-york-large-welded-cooler-bag/8561033>).
- Feb. 9, 2018—U.S. Non-Final Office Action—U.S. Appl. No. 15/451,064.
- May 24, 2018—U.S. Non-final Office Action—U.S. Appl. No. 15/790,926.
- Aug. 29, 2018 (WO)—International Search Report and Written Opinion—App. No. PCT/US18/36608.
- Mar. 21, 2019—(WO) International Search Report and Written Opinion—App. No. PCT/US2018/066040.
- Feb. 4, 2019—(AU) Examination Report—App. No. 2017263566.
- Jul. 3, 2019—(CN) First Office Action—App. No. 201780042659.5.
- Jun. 5, 2019—(AU) Notice of Acceptance for Patent Application—App 2017263566.
- United States District Court Western District of Texas, Austin Division, “Complaint for Damages and Injunctive Relief for: (1)-(12) Patent Infringement in Violation of 35 U.S.C. § 271; and (13) Breach of Contract”, *YETI Coolers, LLC* v. *RTIC Outdoors, LLC; and Corporate Support & Fulfillment, LLC*, Case 1:21-cv-00214, filed Mar. 5, 2021, 338 pages.
- Oct. 2, 2019—(CN) Examiner’s Report—App. No. 2017032351.
- Jun. 3, 2019—(CN) First Office Action—App. No. 201680076714.8.
- amazon.com, “E-MANIS Insulated Lunch Bag Adult Lunch Box Collapsible Multi-Layers Thermal Insulated Oxford Lunch Tote

(56)

References Cited

OTHER PUBLICATIONS

Cooler Bag for Men, women (grey),” visited May 7, 2019 at <https://www.amazon.com/MANIS-Insulated-Portable-Cooler-School/dp/B07BMT6948/ref=sr_1_23?keywords=soft+sided+cooler+lunch+box&qid=1557170800&s=home-garden&sr=1-23>.

amazon.com, “Meal Prep Lunch Bag / Box for Men, Women + 3 Large Food-Containers (45 Oz.) + 2 Big Reusable Ice Packs + Shoulder Strap + Shaker With Storage. Insulated Lunchbox Cooler Tote. Adult Portion Control Set,” visited May 7, 2019 at <[https://www.amazon.com/Meal-Containers-Reusable-Shoulder-Insulated/dp/B01MU2YS18/ref=pd_day0_hl_79_1/140-0306592-8455572?_encoding=UTF8&pd_rd_i=B01MU2YS18&pd_rd_r=d48c8802-70e2-11e9-88f1-c5c4d7a27c00&pd_rd_w=r75Rf&pd_rd_wg=9VNz5&pf_rd_p=ad07871c-e646-4161-82c7-5ed0d4c85b07&pf_rd_r=1ADFSK8XZQ9P7920M0B7&psc=1&refRID=1ADFSK8XZQ9P7920M0B7](https://www.amazon.com/Meal-Containers-Reusable-Shoulder-Insulated/dp/B01MU2YS18/ref=pd_day0_hl_79_1/140-0306592-8455572?_encoding=UTF8&pd_rd_i=B01MU2YS18&pd_rd_r=d48c8802-70e2-11e9-88f1- at <https://www.amazon.com/Meal-Containers-Reusable-Shoulder-Insulated/dp/B01MU2YS18/ref=pd_day0_hl_79_1/140-0306592-8455572?_encoding=UTF8&pd_rd_i=B01MU2YS18&pd_rd_r=d48c8802-70e2-11e9-88f1-c5c4d7a27c00&pd_rd_w=r75Rf&pd_rd_wg=9VNz5&pf_rd_p=ad07871c-e646-4161-82c7-5ed0d4c85b07&pf_rd_r=1ADFSK8XZQ9P7920M0B7&psc=1&refRID=1ADFSK8XZQ9P7920M0B7)>.

amazon.com, “ZUZURO Lunch Bag Insulated Cooler Lunch Box w/ 3 Compartment—Heavy-Duty Fabric, Strong SBS Zippers—Includes 3 Meal Prep Lunch box Containers + 2 Ice Packs. For Men Women Adults (Black),” visited May 7, 2019 at <https://www.amazon.com/Zuzuro-Lunch-Insulated-Cooler-Compartment/dp/B079DZ2L1F/ref=sr_1_14?keywords=lunch+box+lid+ice+pack&qid=1557245496&s=gateway&sr=8-14>.

amazon.com, “MIER Portable Thermal Insulated Cooler Bag Mini Lunch Bag for Kids, Black,” visited May 7, 2019, at <[https://www.amazon.com/MIER-Portable-Thermal-Insulated-Cooler/dp/B01145L2JM/ref=pd_bxgy_img_3/140-0306592-8455572?_encoding=UTF8&pd_rd_i=B01145L2JM&pd_rd_r=e6f0c649-7034-11e9-93e4-9f5b0bbd650f&pd_rd_w=86WKd&pd_rd_wg=yvYrJ&pf_rd_p=a2006322-0bc0-4db9-a08e-d168c18ce6f0&pf_rd_r=KZ69E53Y49BFE9YFEJAM&psc=1&refRID=KZ69E53Y49BFE9YFEJAM](https://www.amazon.com/MIER-Portable-Thermal-Insulated-Cooler/dp/B01145L2JM/ref=pd_bxgy_img_3/140-0306592-8455572?_encoding=UTF8&pd_rd_i=B01145L2JM&pd_rd_r=e6f0c649-7034-11e9-93e4-9f5b0bbd650f&pd_rd_w=86WKd&pd_rd_wg=yvYrJ&pf_rd_p=a2006322-0bc0-4db9-a08e- at <https://www.amazon.com/MIER-Portable-Thermal-Insulated-Cooler/dp/B01145L2JM/ref=pd_bxgy_img_3/140-0306592-8455572?_encoding=UTF8&pd_rd_i=B01145L2JM&pd_rd_r=e6f0c649-7034-11e9-93e4-9f5b0bbd650f&pd_rd_w=86WKd&pd_rd_wg=yvYrJ&pf_rd_p=a2006322-0bc0-4db9-a08e-d168c18ce6f0&pf_rd_r=KZ69E53Y49BFE9YFEJAM&psc=1&refRID=KZ69E53Y49BFE9YFEJAM)>.

amazon.com, “Strotek Lunch Bag Insulated Lunch Box Tote Bag Cooler Bag Water-resistant Cute Lunch Bag Wide-open Thermal Tote Kit for Women/Girls/Work/Picnic, Grey Flamingo,” visited May 7, 2019 at <https://www.amazon.com/dp/B07N57JSJS/ref=sspa_dk_detail_9?psc=1&pd_rd_i=B07N57JSJS>.

amazon.com, “MIER Insulated Double Casserole Carner Thermal-Lunch Tote for Potluck Parties, Picnic, Beach—Fits 9”x13” Casserole Dish, Expandable, Orange,” visited May 7, 2019 at <https://www.amazon.com/MIER-Insulated-Casserole-Carrier-Thermal/dp/B01N0PW1I9/ref=pd_day0_hl_79_8?_encoding=UTF8&pd_rd_i=B01N0PW1I9&pd_rd_r=f49708f1-7034-11e9-8500-7b430b359b4b&pd_rd_w=i3agO&pd_rd_wg=M30rG&pf_rd_p=ad07871c-at <https://www.amazon.com/MIER-Insulated-Casserole-Carrier-Thermal/dp/B01N0PW1I9/ref=pd_day0_hl_79_8?_encoding=UTF8&pd_rd_i=B01N0PW1I9&pd_rd_r=f49708f1-7034-11e9-8500-7b430b359b4b&pd_rd_w=i3agO&pd_rd_wg=M30rG&pf_rd_p=ad07871c-e646-4161-82c7-5ed0d4c85b07&pf_rd_r=VX2FPTX9EEFYRBWP5Y2Q&psc=1&refRID=VX2FPTX9EEFYRBWP5Y2Q>.

amazon.com, “Lifewit Insulated Casserole Dish Carrier Thermal Lasagna Luggger for Potluck Parties/Picnic/Beach, Lunch Bag to Keep Food Hot/Cold, 16.3 x 12.6 x 4.7”, Grey,” visited May 7, 2019 at <https://www.amazon.com/dp/B07BFWJPV5/ref=sspa_dk_detail_6?psc=1&pd_rd_i=B07BFWJPV5&pd_rd_w=tr7Ke&pf_rd_p=46cdcf7-b302-4268-b799-8f7d8cb5008b&pd_rd_wg=jq3TO&pf_rd_r=W7MFCBJR9DR0HV3AKZZB&pd_rd_r=604844a0-70d3-11e9-ad99-d763d3fc76f8>.

amazon.com, “Arctic Zone 2008IL515B42 Thermal Insulated Hot/Cold Food Carrier, Green,” visited May 7, 2019 at <https://www.amazon.com/dp/B077T7FZBX/ref=sspa_dk_detail_0?psc=1&pd_rd_i=B077T7FZBX>.

amazon.com, “Lille Home 2nd Gen 22oz Stainless Steel Leakproof Lunch Box, Insulated Bento Box/Food Container with Insulated Lunch Bag | Durable Handles and Lid | Adults, Kids | Men, Women (Green),” visited May 8, 2019 at <https://www.amazon.com/dp/B07MBDD29C/ref=sspa_dk_detail_3?psc=1&pd_rd_i=B07MBDD29C&pd_rd_w=kCuXU&pf_rd_p=46cdcf7-b302-4268-b799-8f7d8cb5008b&pd_rd_wg=3ZMcX&pf_rd_r=HKB02Z8TMK0Y3QND9VV8&pd_rd_r=be6892d-70d5-11e9- at <https://www.amazon.com/dp/B07MBDD29C/ref=sspa_dk_detail_3?psc=1&pd_rd_i=B07MBDD29C&pd_rd_w=kCuXU&pf_rd_p=46cdcf7-b302-4268-b799-8f7d8cb5008b&pd_rd_wg=3ZMcX&pf_rd_r=HKB02Z8TMK0Y3QND9VV8&pd_rd_r=be6892d-70d5-11e9-a563-4fe76fa75f96>.

amazon.com, “Lille-22oz Stainless Steel Leakproof Lunch Box, Insulated Bento Boxes | Thermal Food Container with Insulated Lunch Bag for Work | 2nd Gen with Durable Handle and Lid | BPA free | Adult, Women, Kid,” visited May 7, 2019 at <https://www.amazon.com/Lille-Stainless-Leakproof-Insulated-Container/dp/B07HDTMJ7M/ref=pd_sbs_79_2/140-0306592-8455572?_encoding=UTF8&pd_rd_i=B07HDTMJ7M&pd_rd_r=2d538b12-70d7-11e9-8561-7333deb843e8&pd_rd_w=7Nrr0&pd_at <https://www.amazon.com/Lille-Stainless-Leakproof-Insulated-Container/dp/B07HDTMJ7M/ref=pd_sbs_79_2/140-0306592-8455572?_encoding=UTF8&pd_rd_i=B07HDTMJ7M&pd_rd_r=2d538b12-70d7-11e9-8561-7333deb843e8&pd_rd_w=7Nrr0&pd_rd_wg=2Z0BJ&pf_rd_p=588939de-d3f8-42f1-a3d8-d556ae5797d&pf_rd_r=5XJVRVFVEAZ3BBEY9MQXF&psc=1&refRID=5XJVRVFVEAZ3BBEY9MQXF>.

Dec. 13, 2019—(CN) First Office Action—App. No. 201780020473.

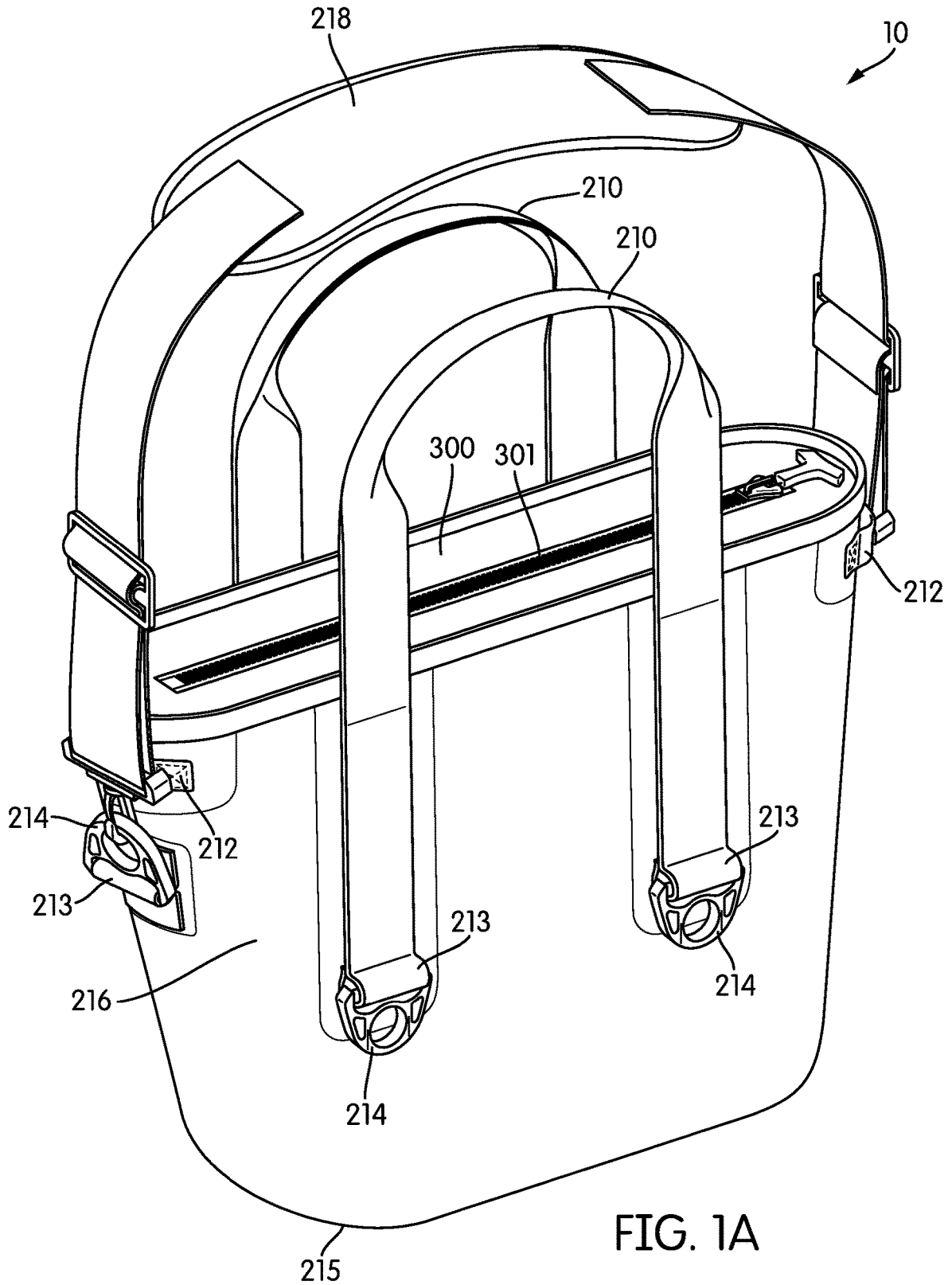

FIG. 1A

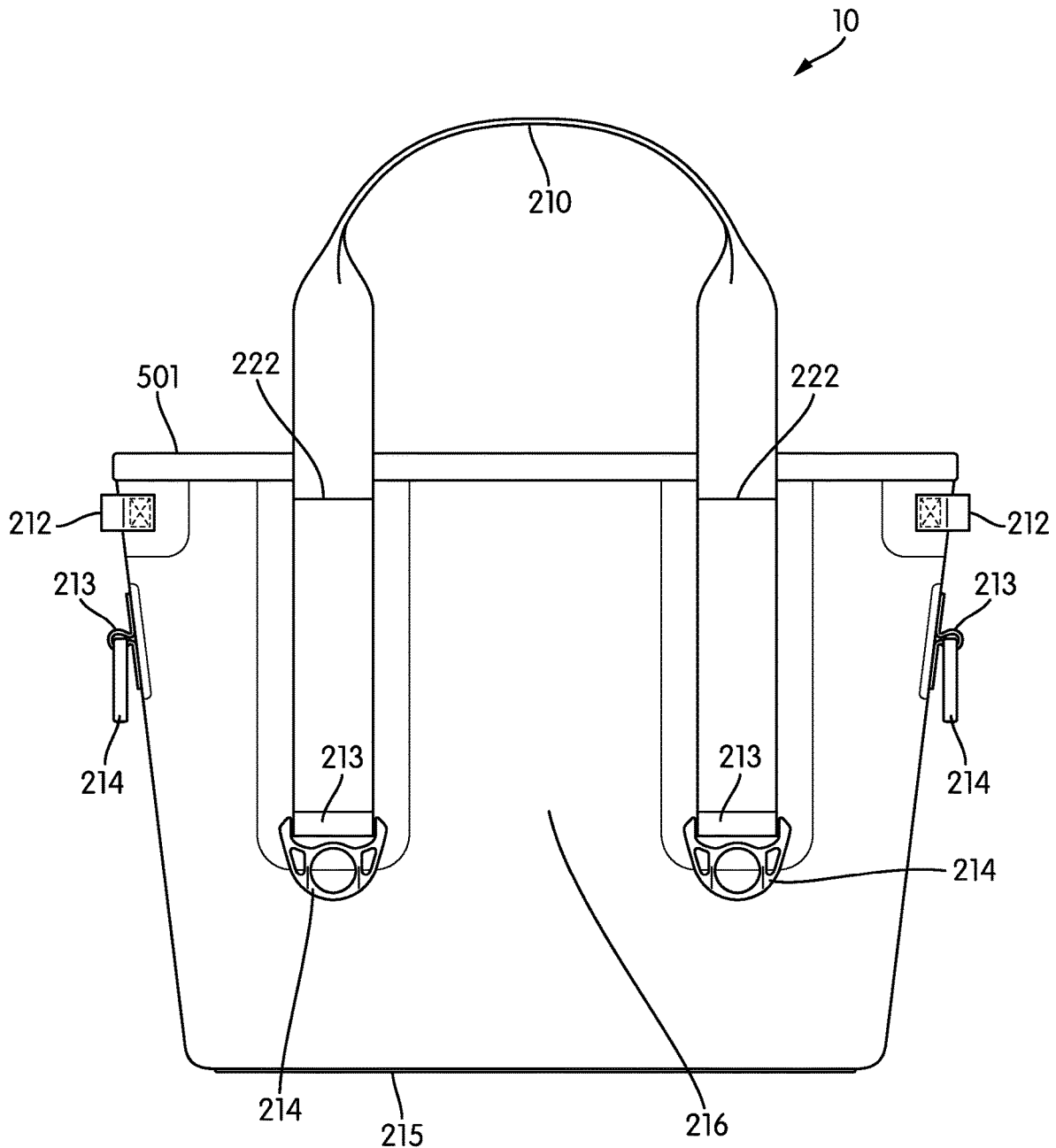

FIG. 1B

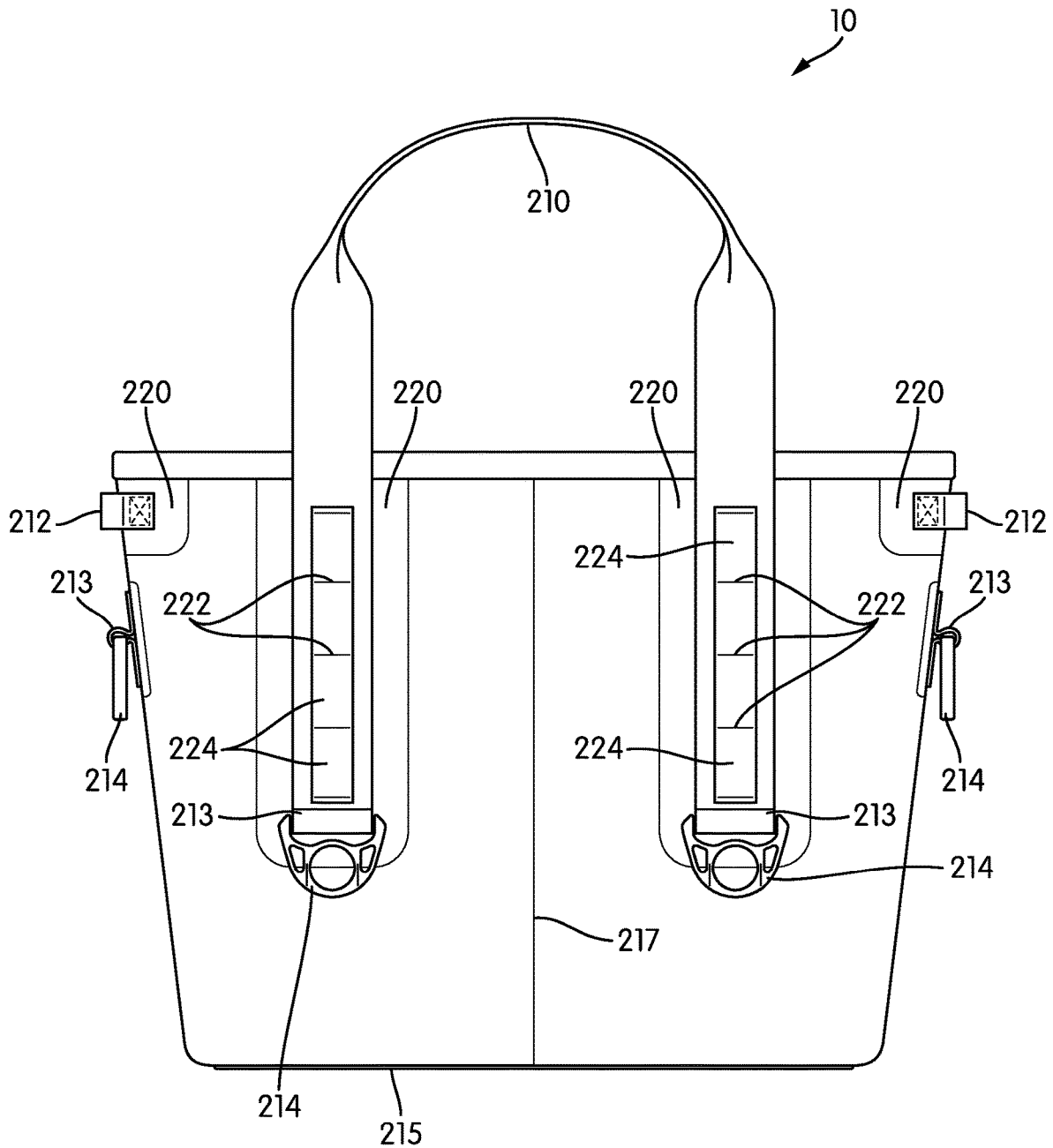

FIG. 2

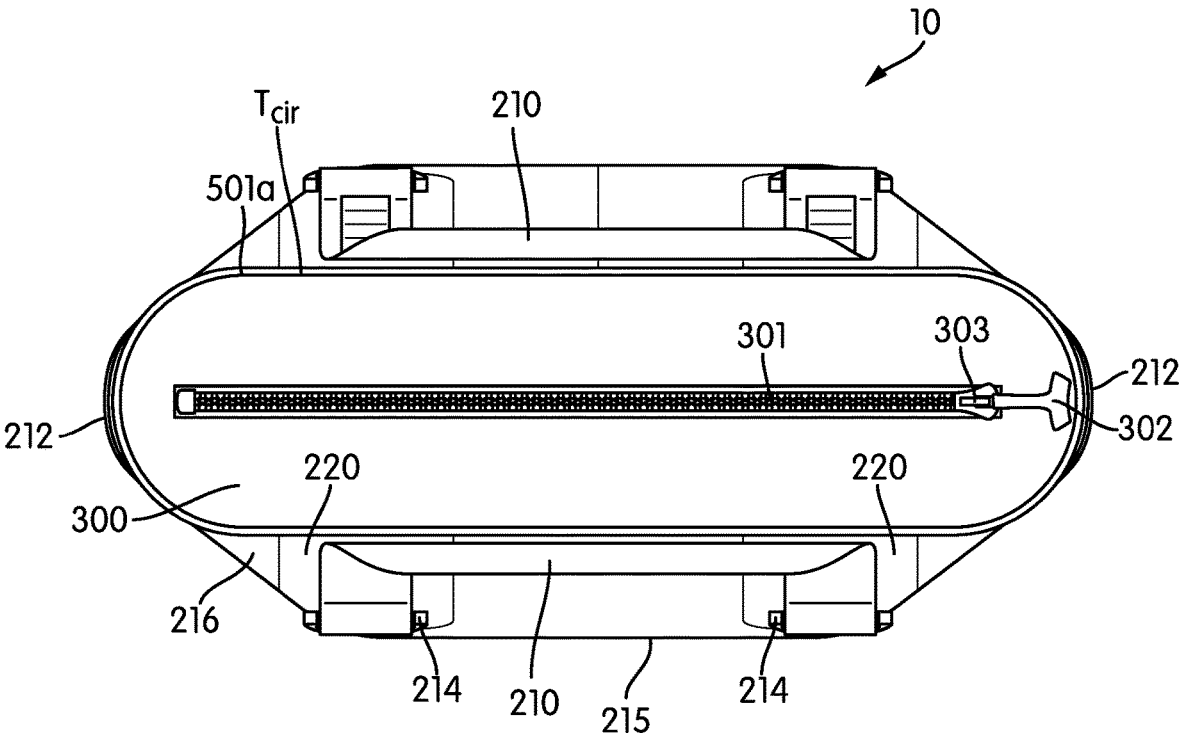

FIG. 3A

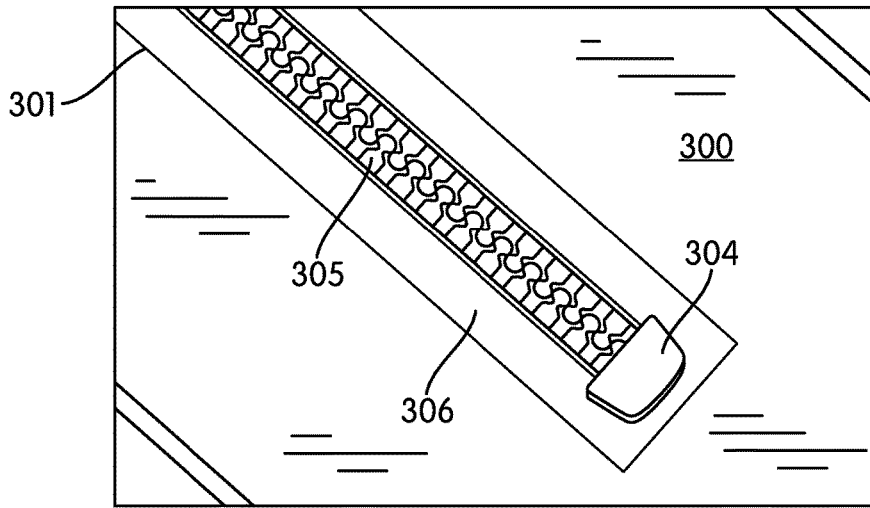

FIG. 3B

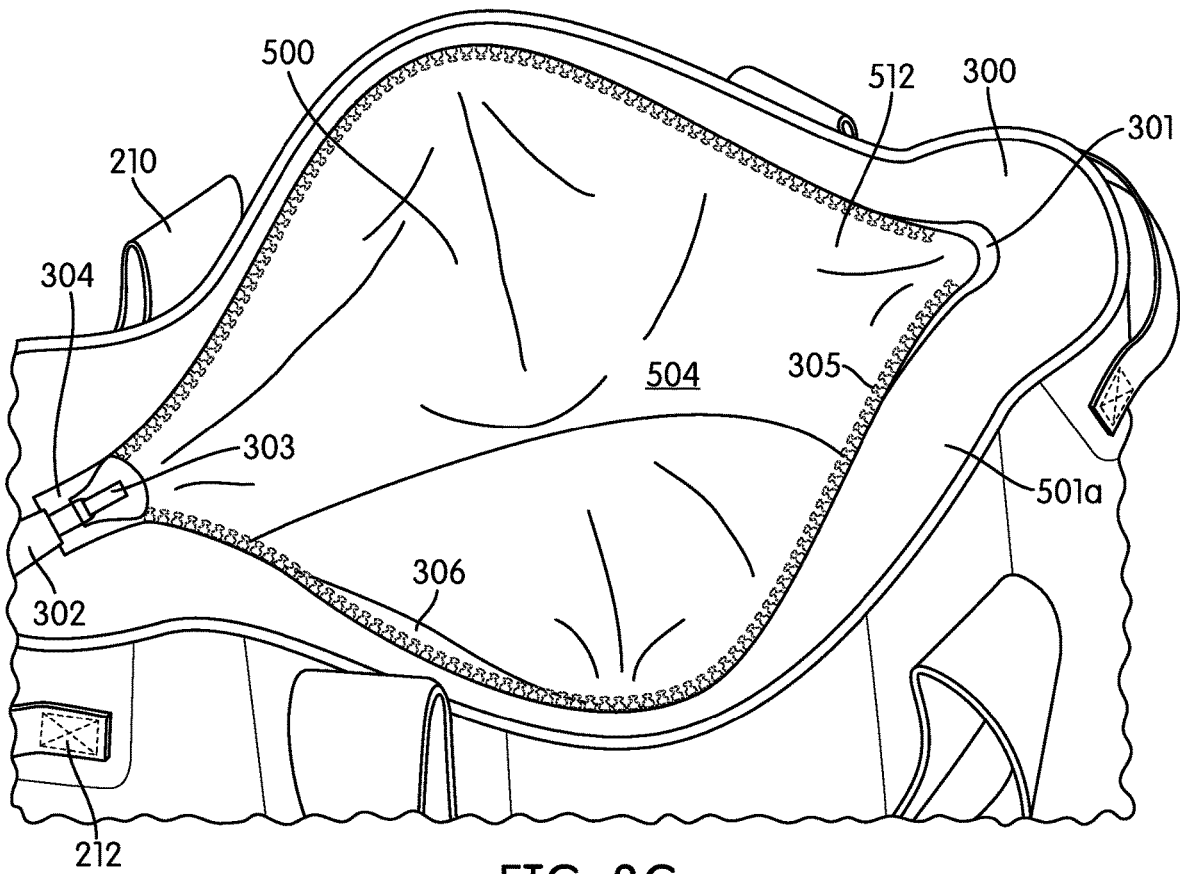

FIG. 3C

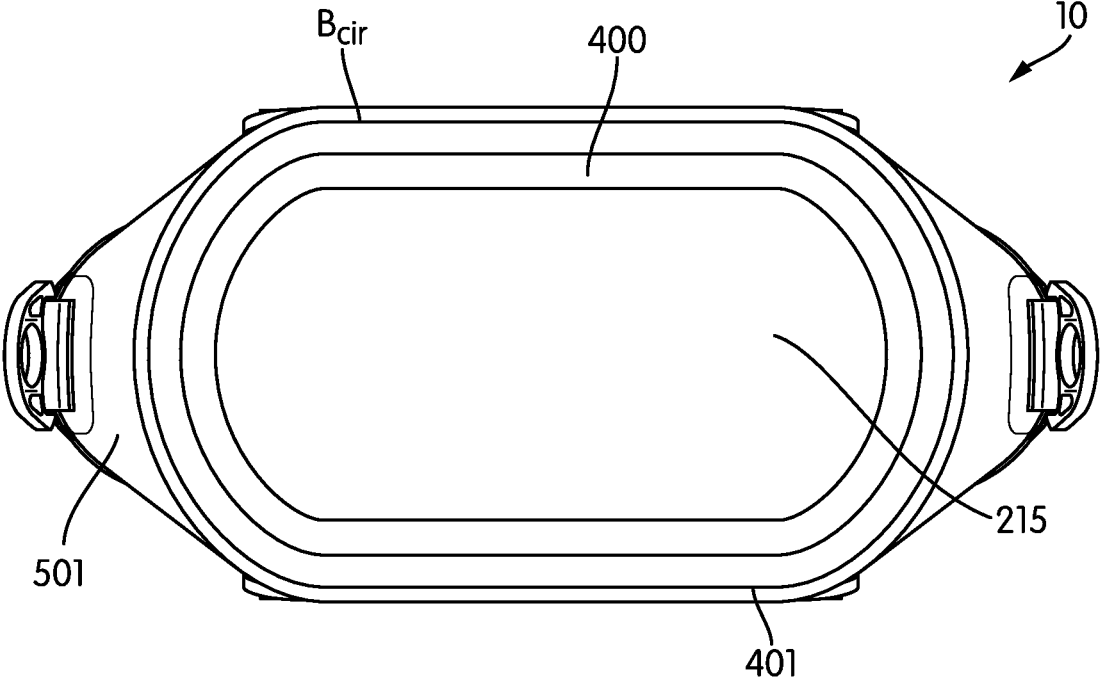

FIG. 4

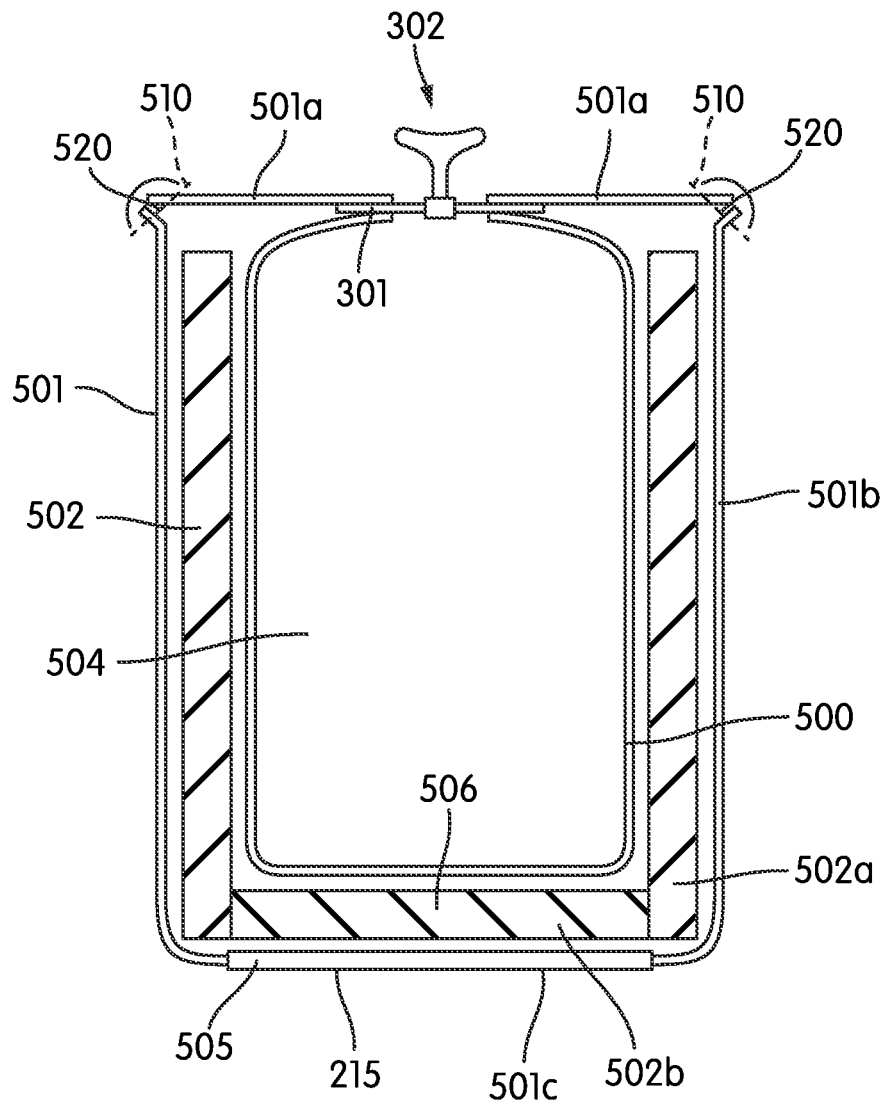

FIG. 5A

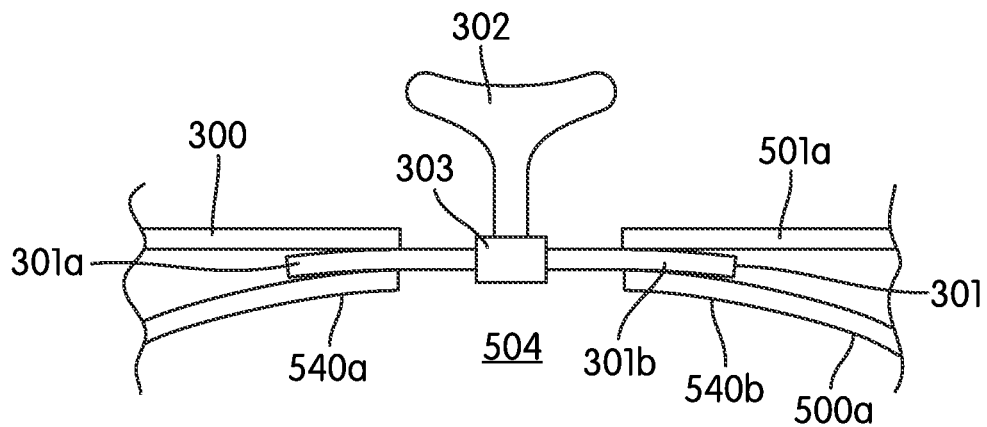

FIG. 5B

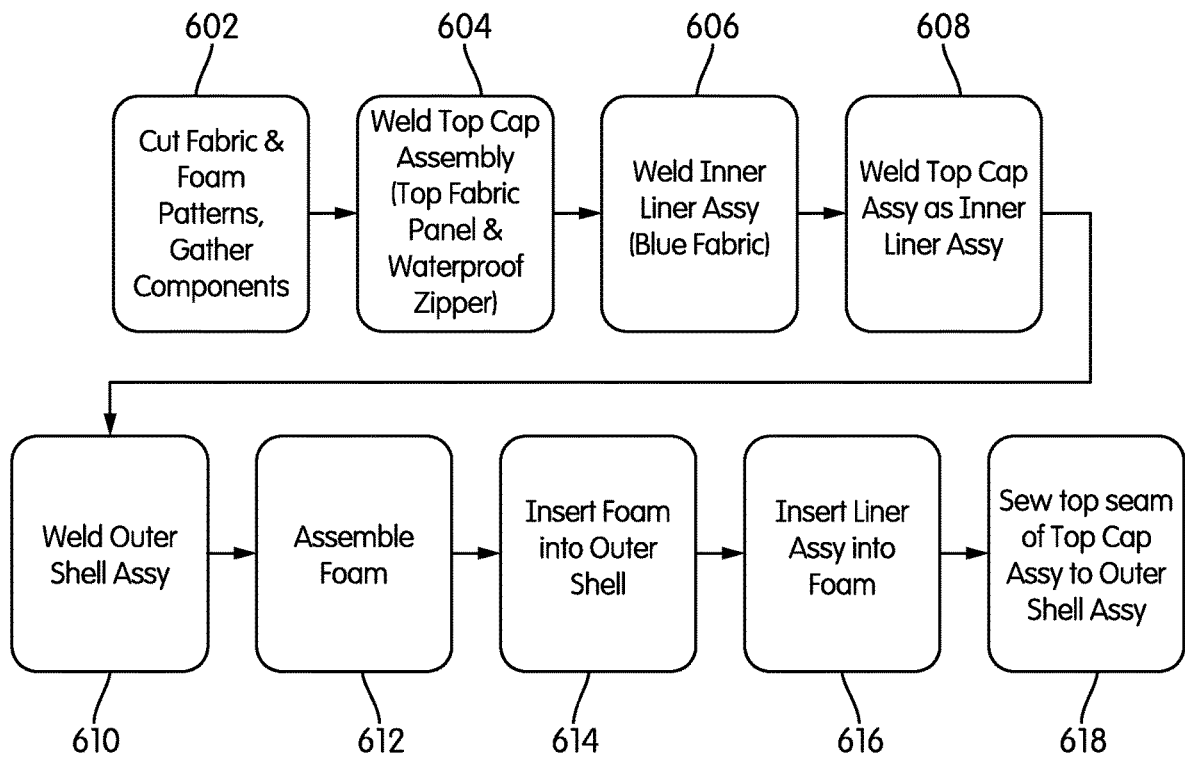

FIG. 6

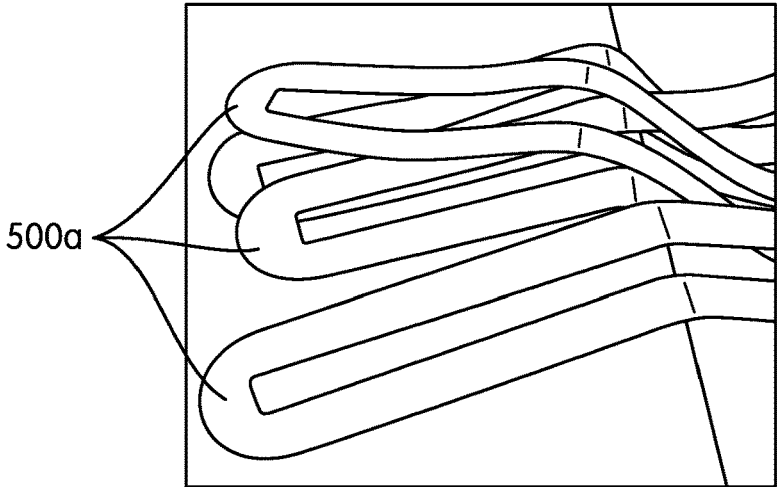

FIG. 7A

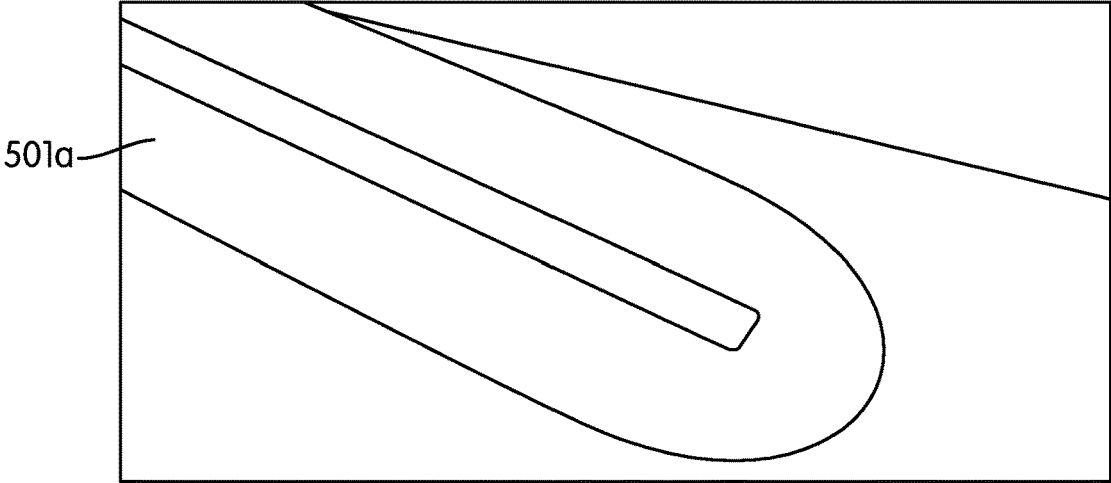

FIG. 7B

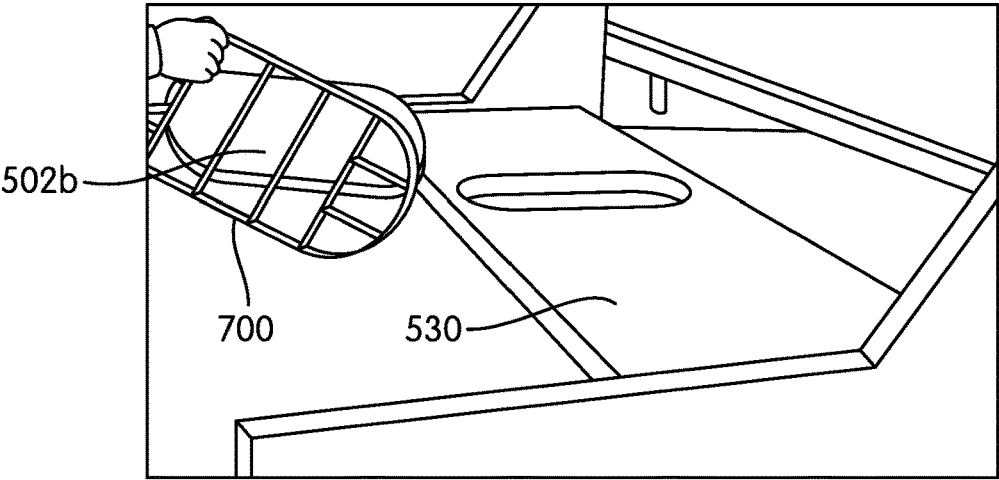

FIG. 7C

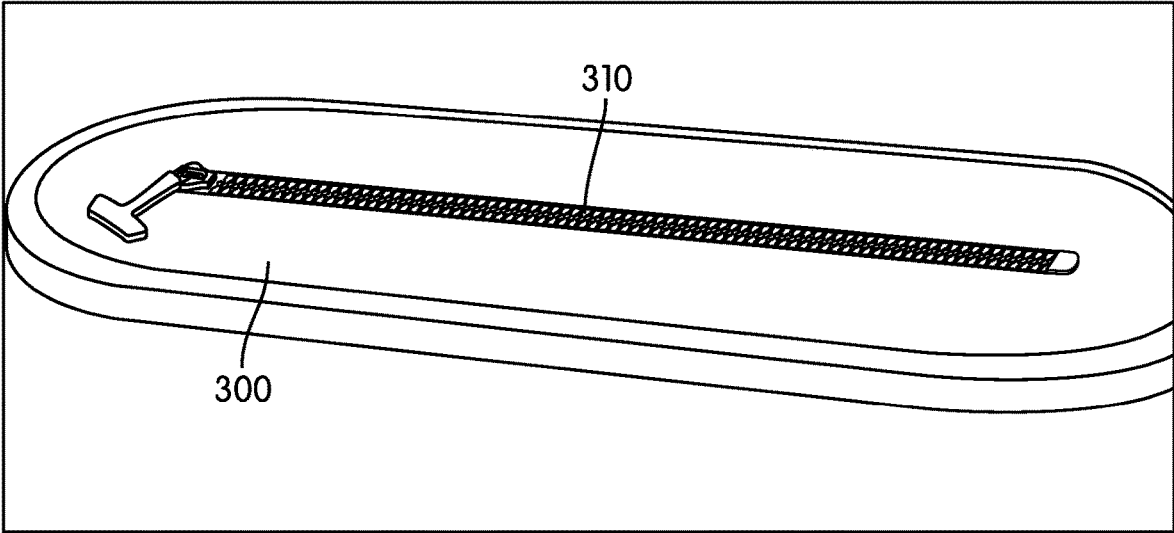

FIG. 7D

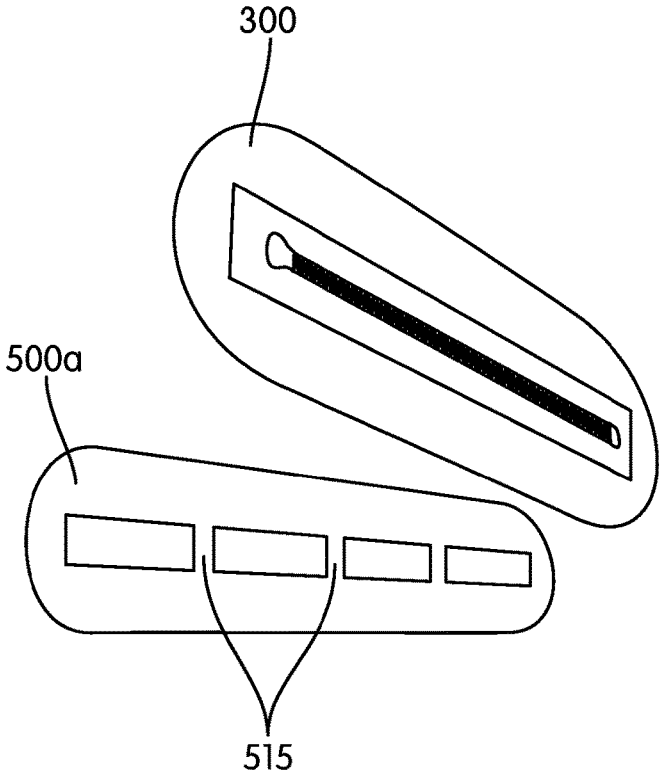

FIG. 7E

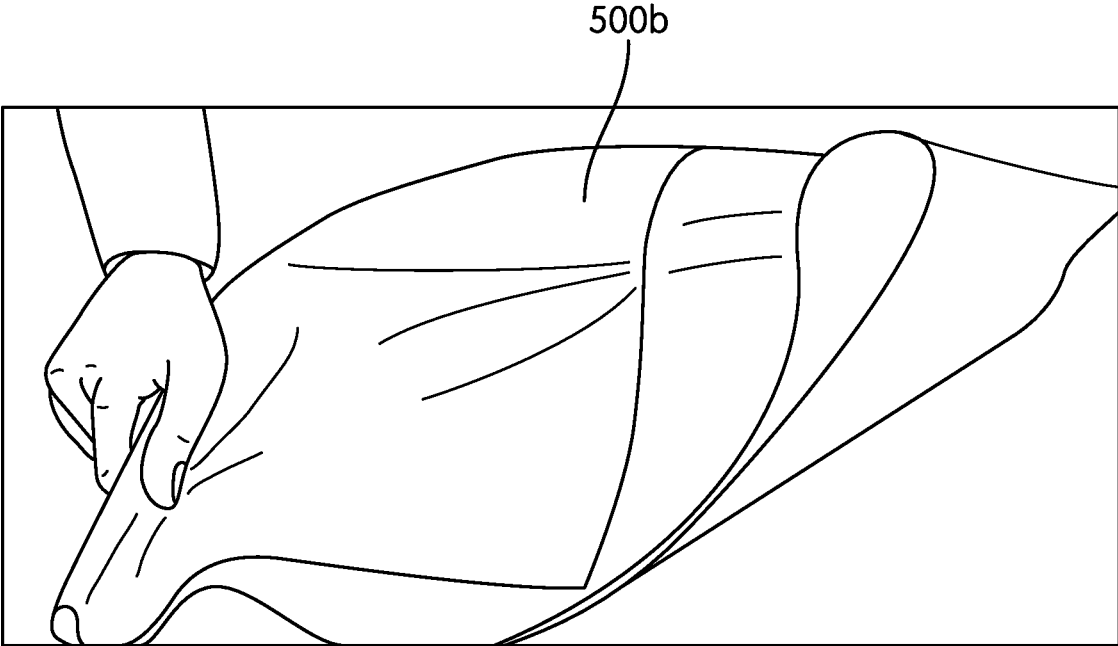

FIG. 7F

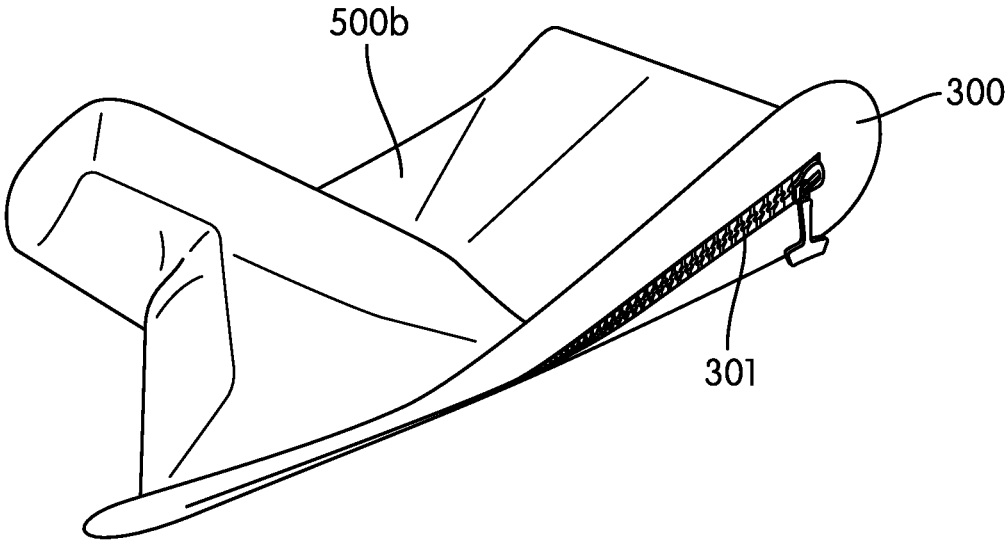

FIG. 7G

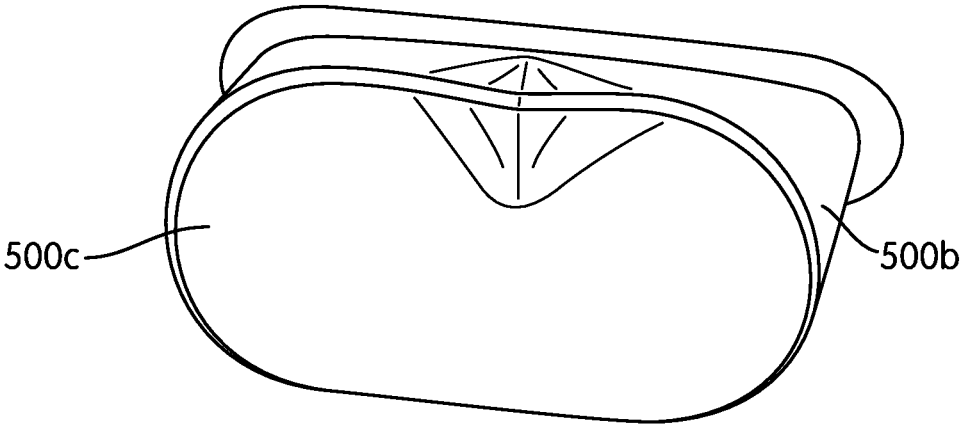

FIG. 7H

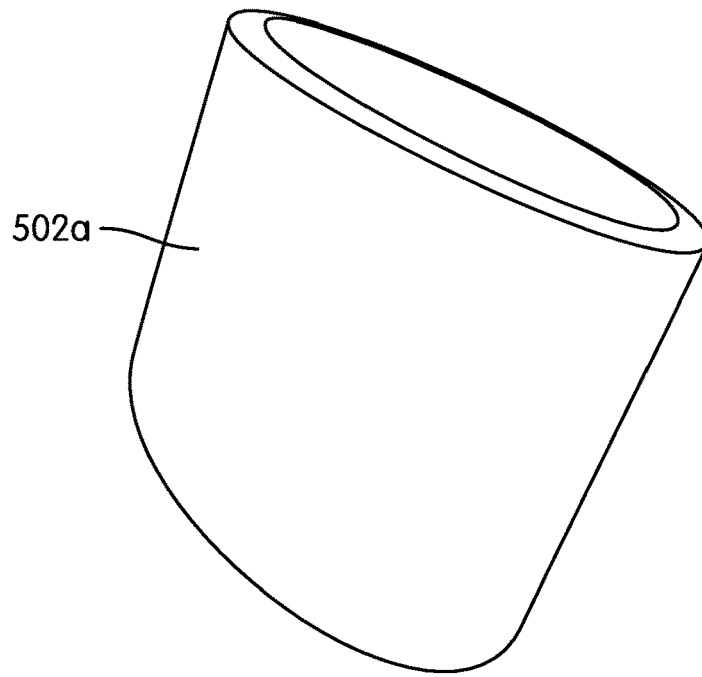

FIG. 7I

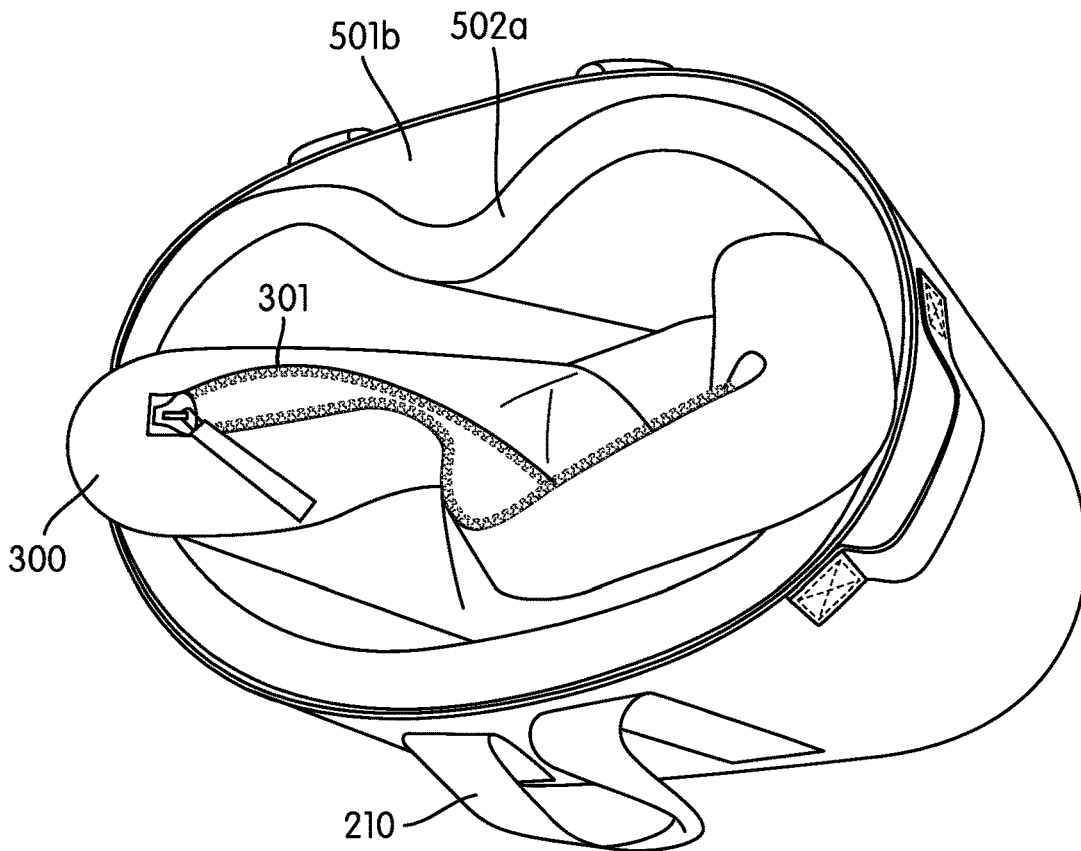

FIG. 7J

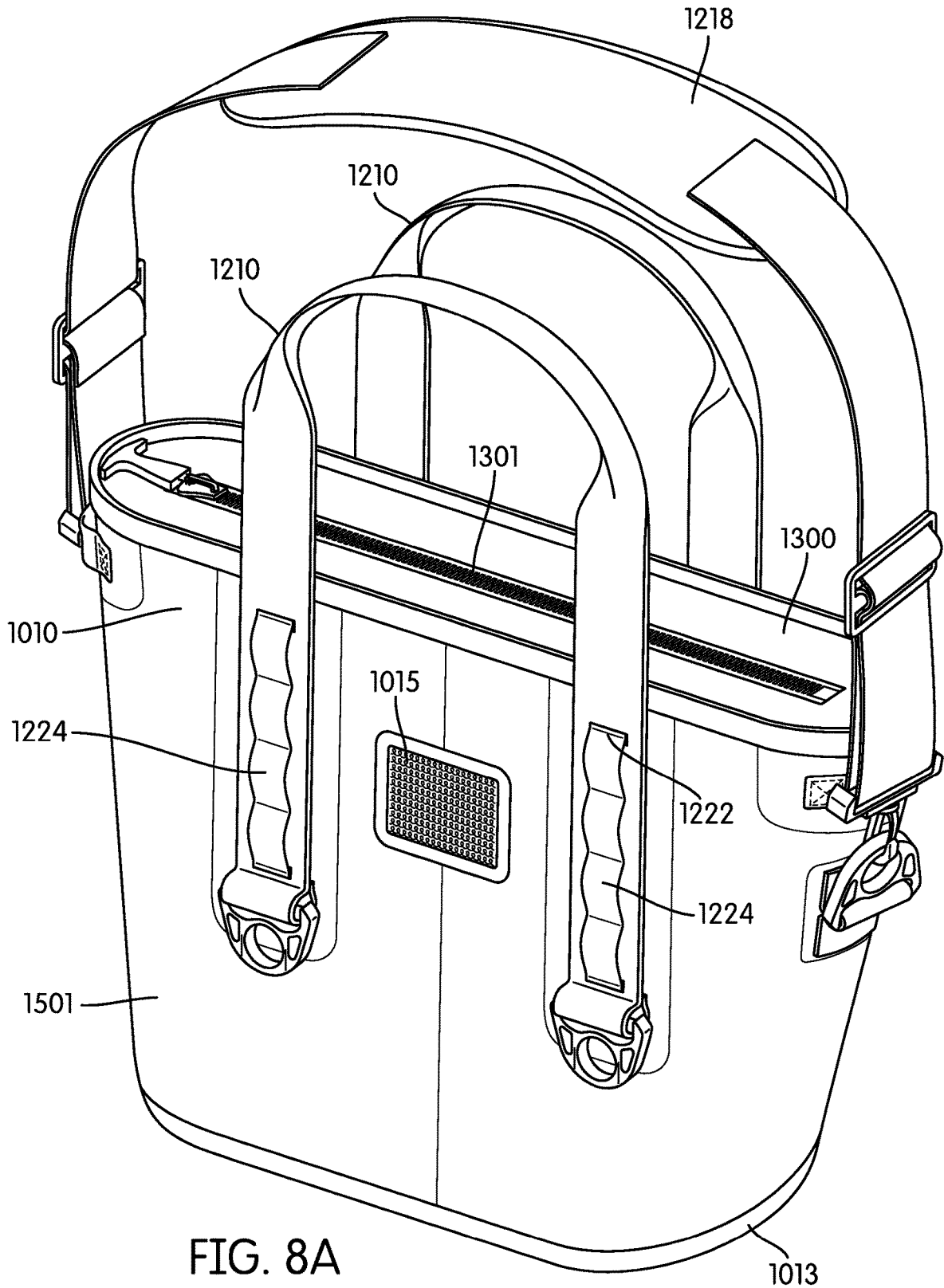
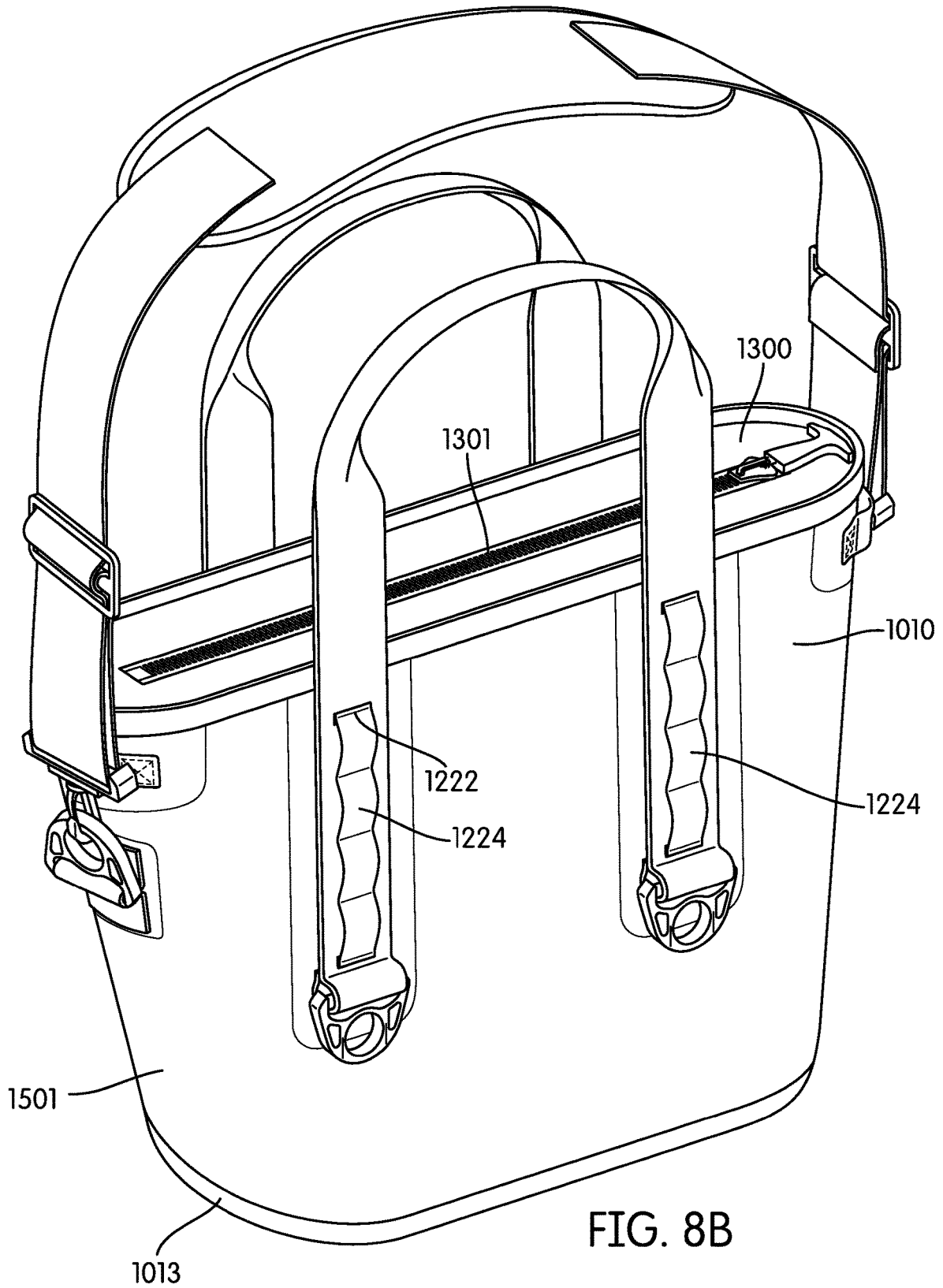

FIG. 8A



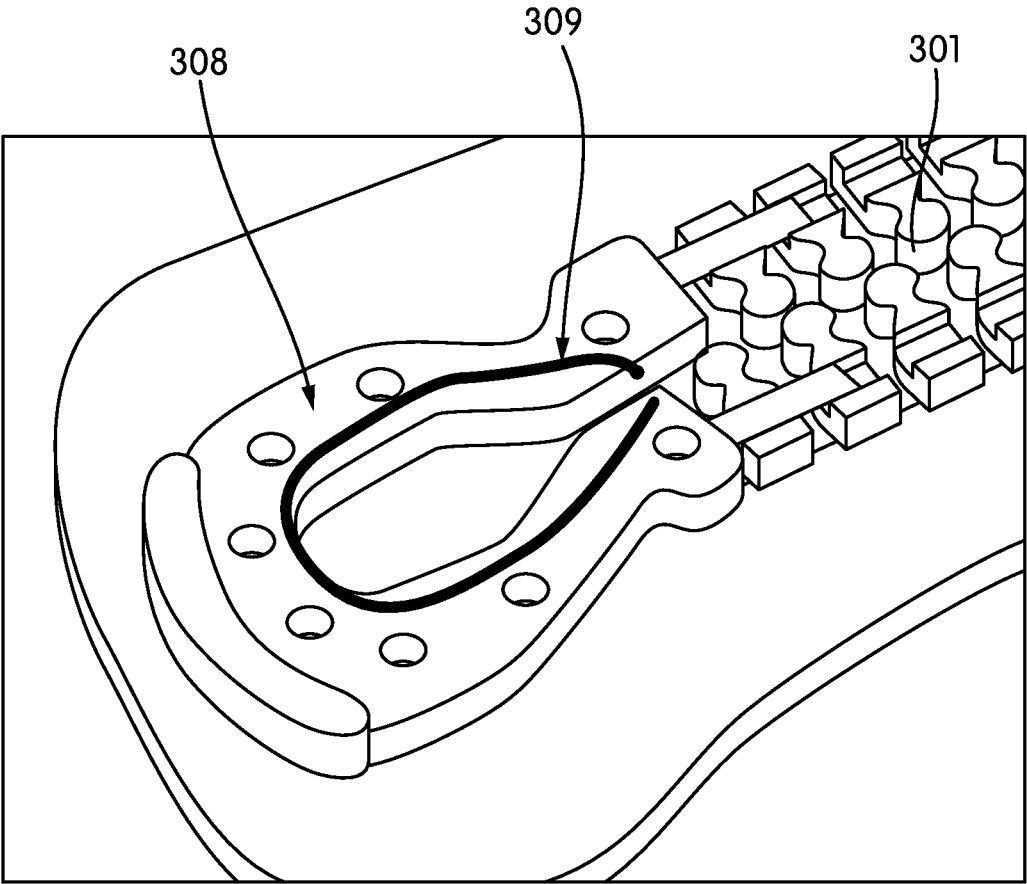

FIG. 9

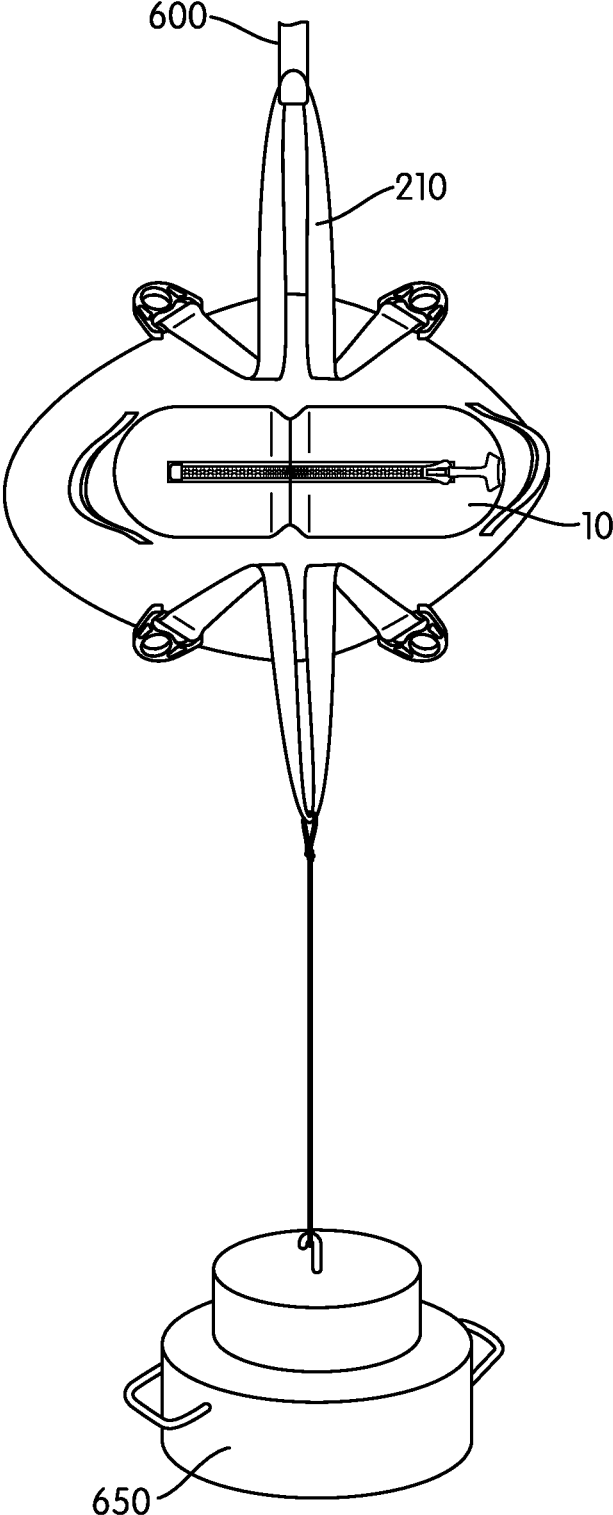

FIG. 10

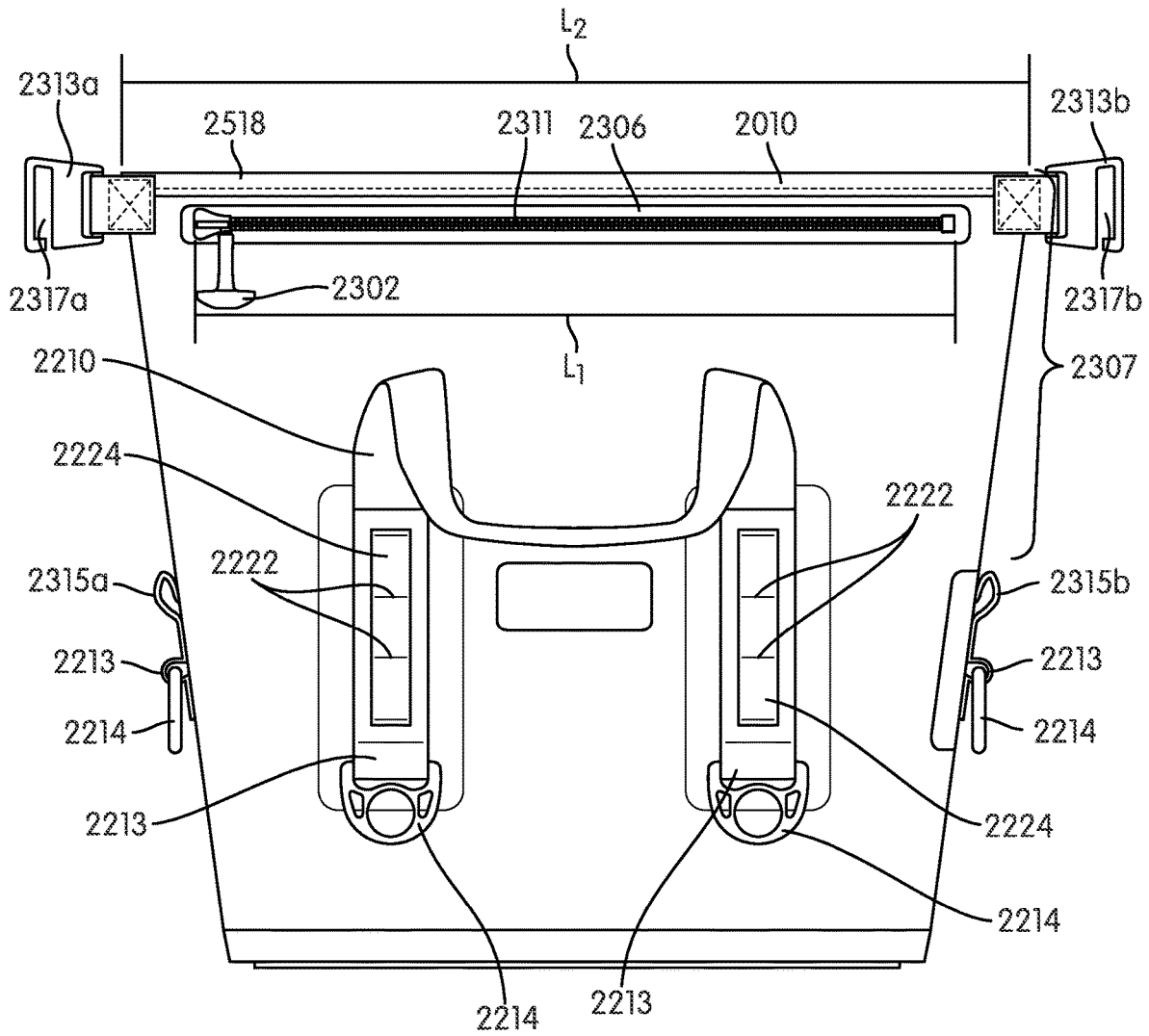

FIG. 11

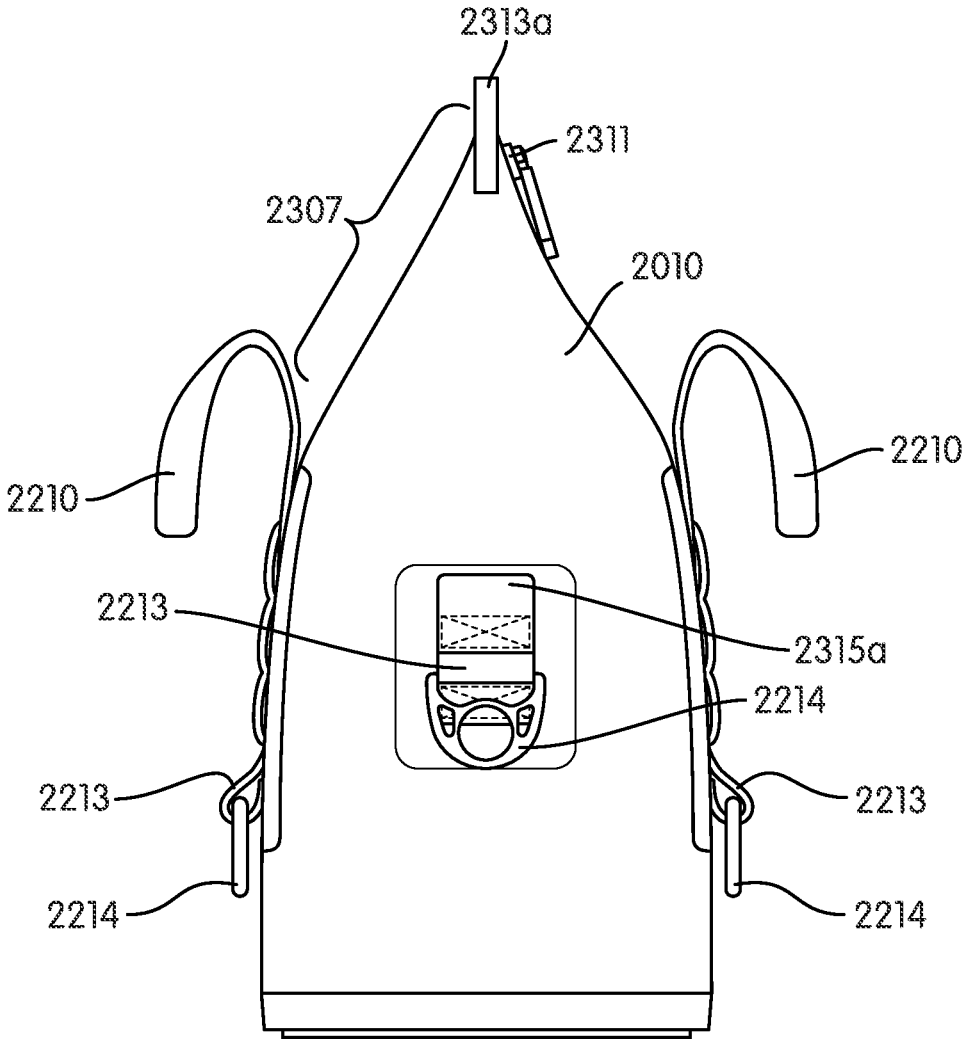

FIG. 12

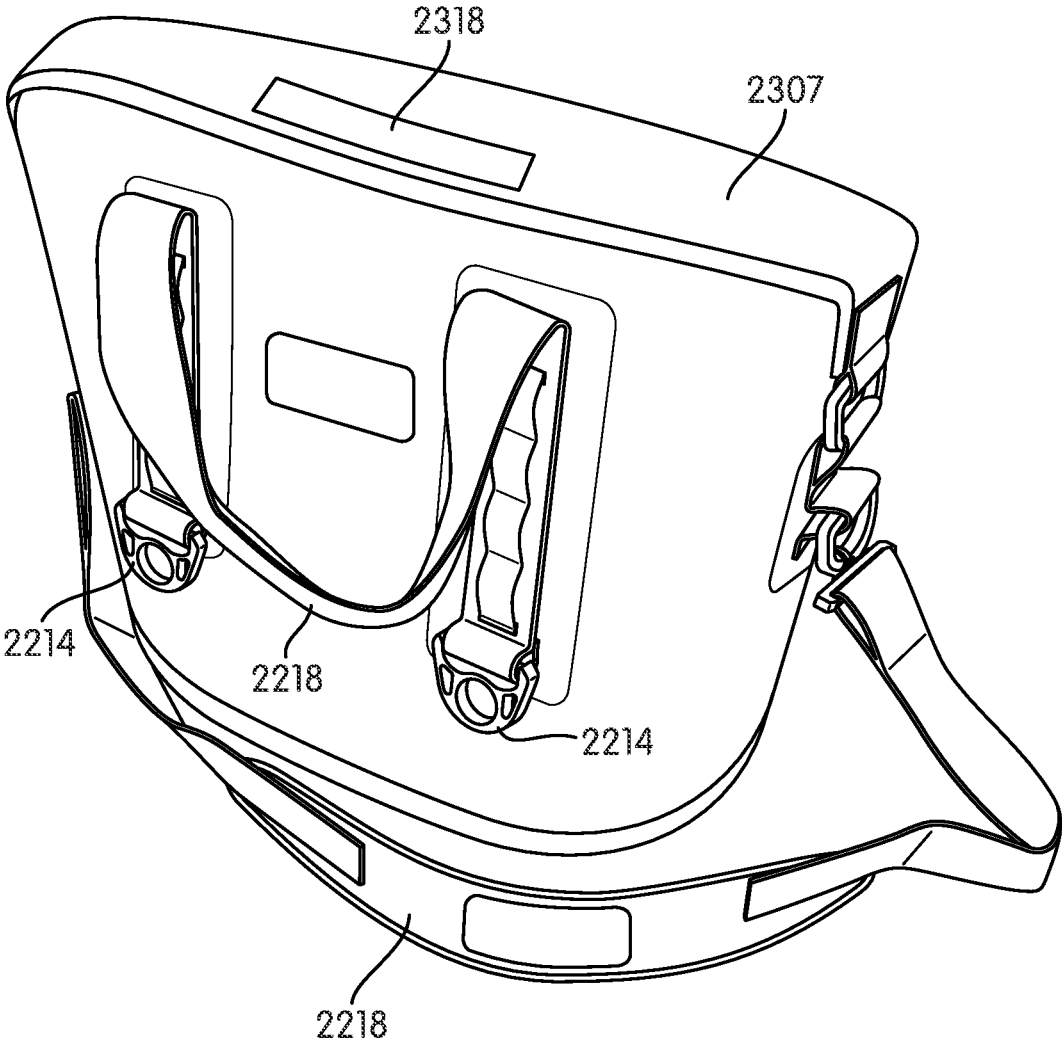

FIG. 13

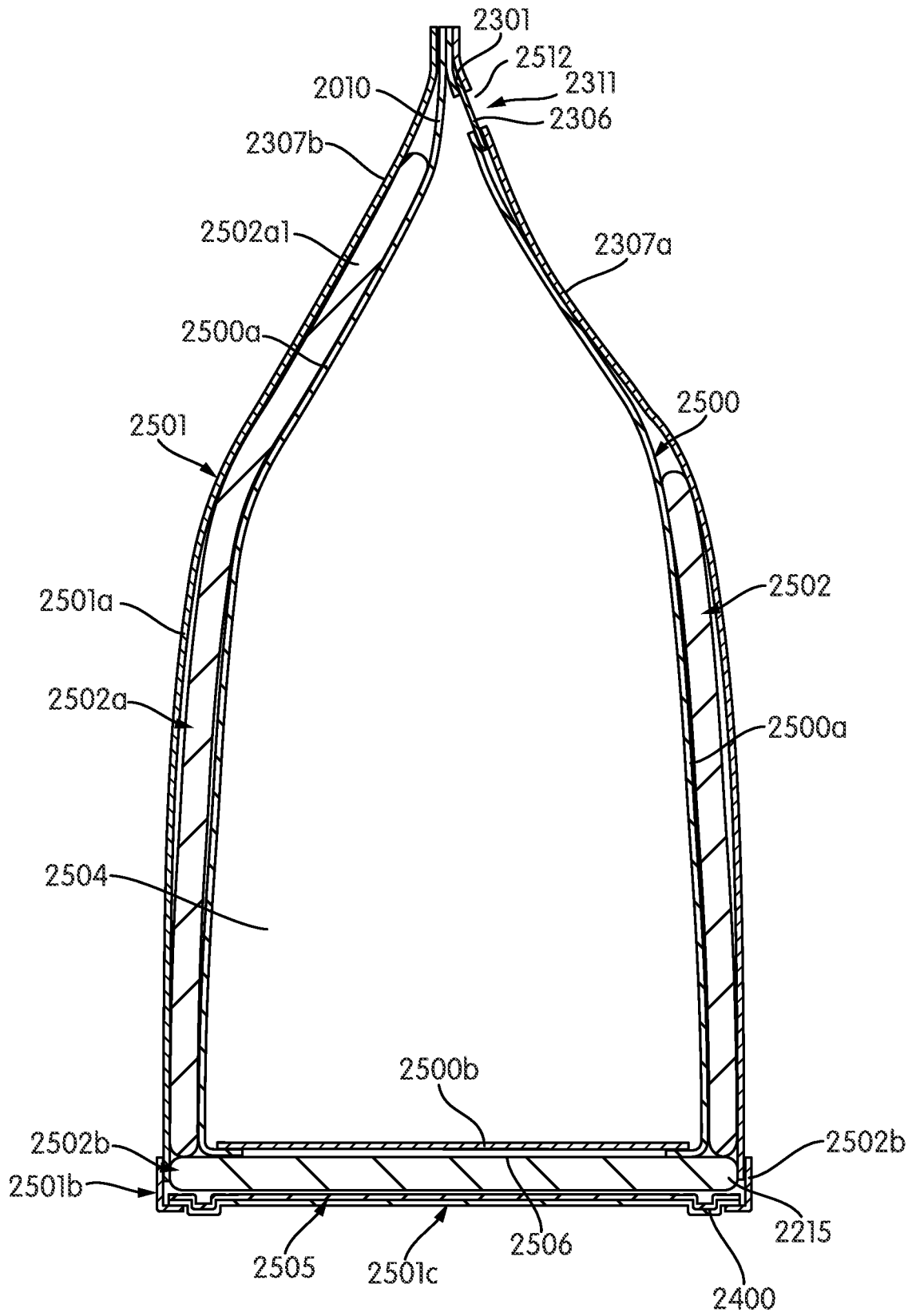

FIG. 14A

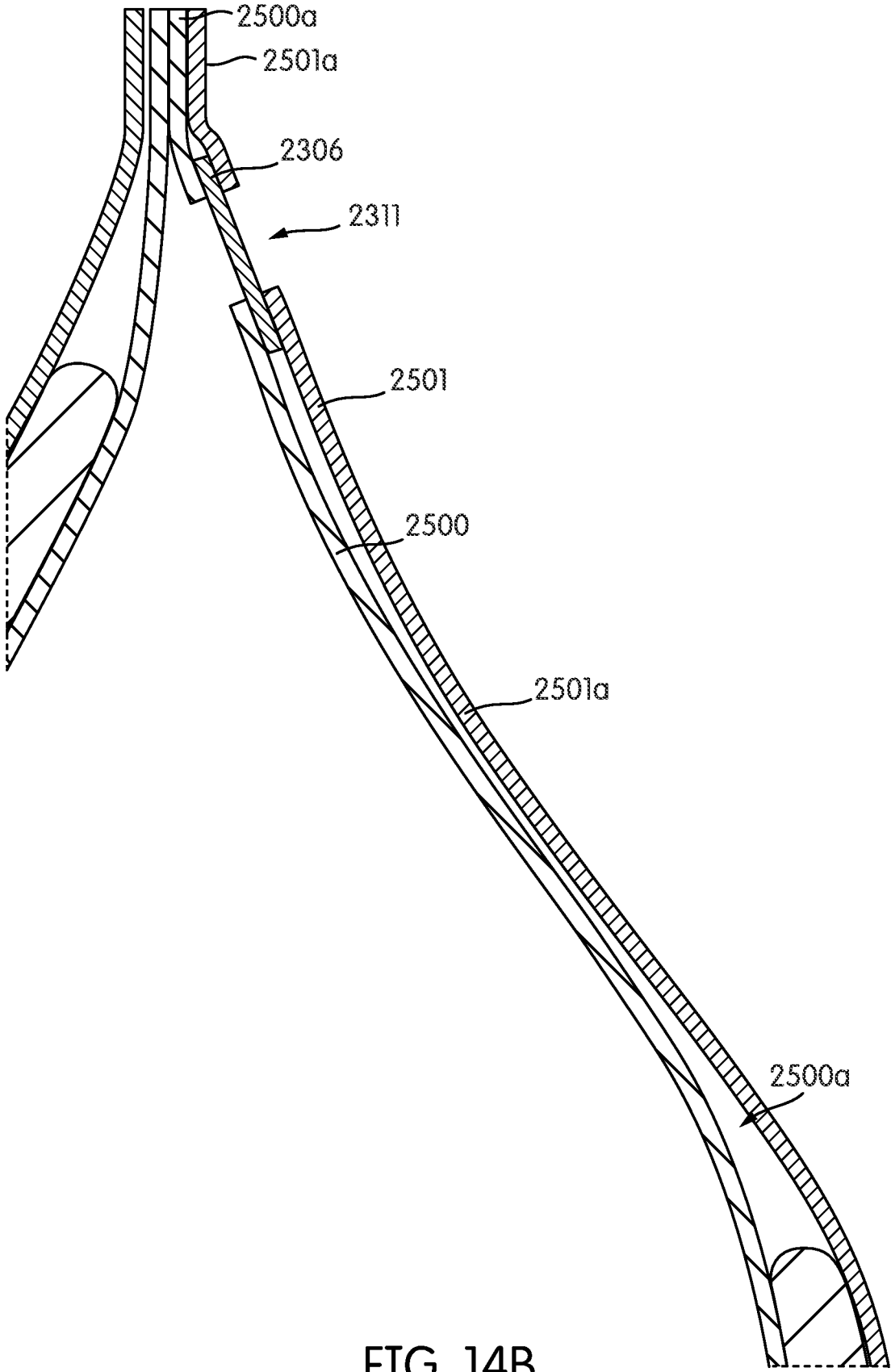

FIG. 14B

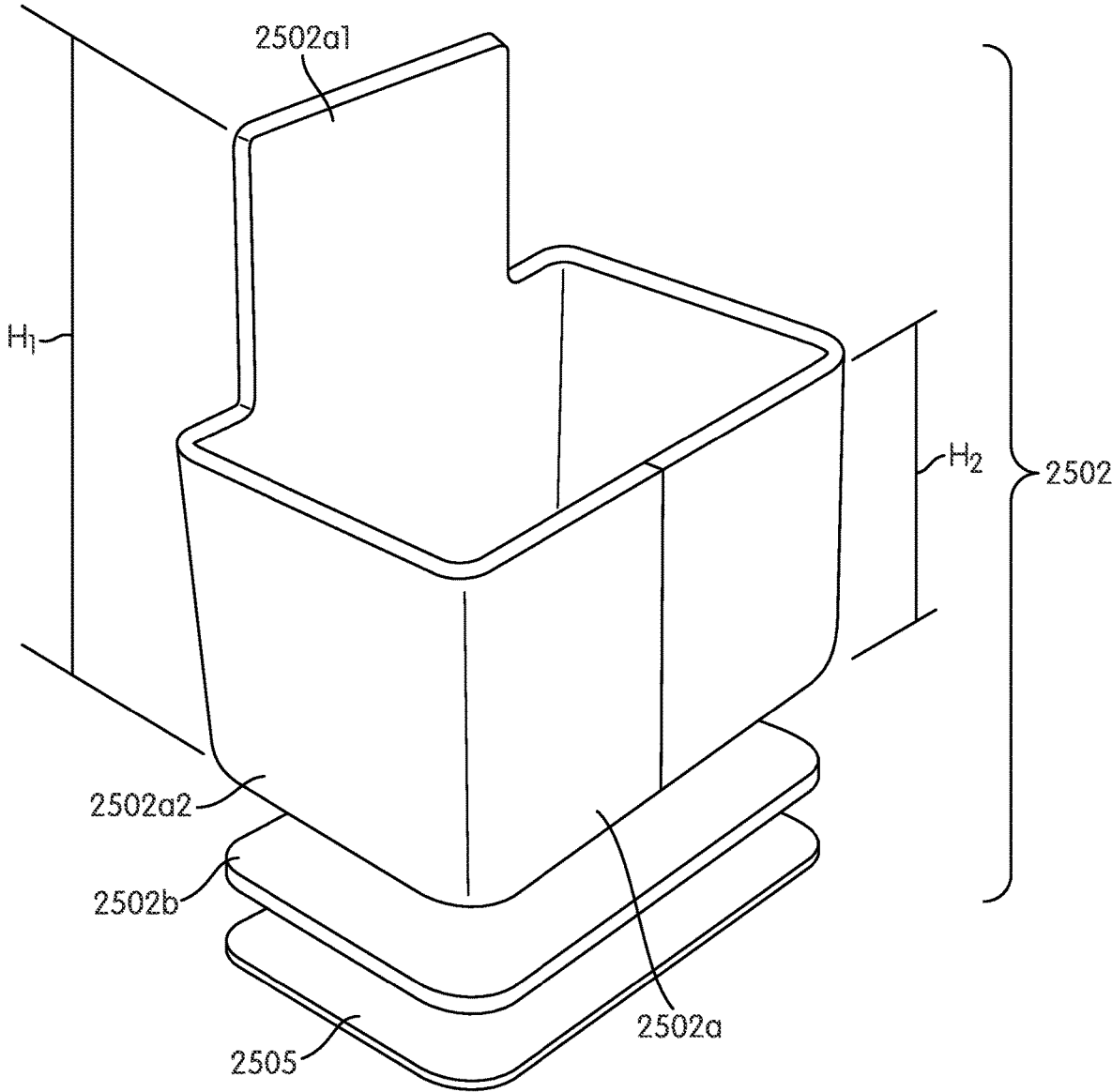

FIG. 15

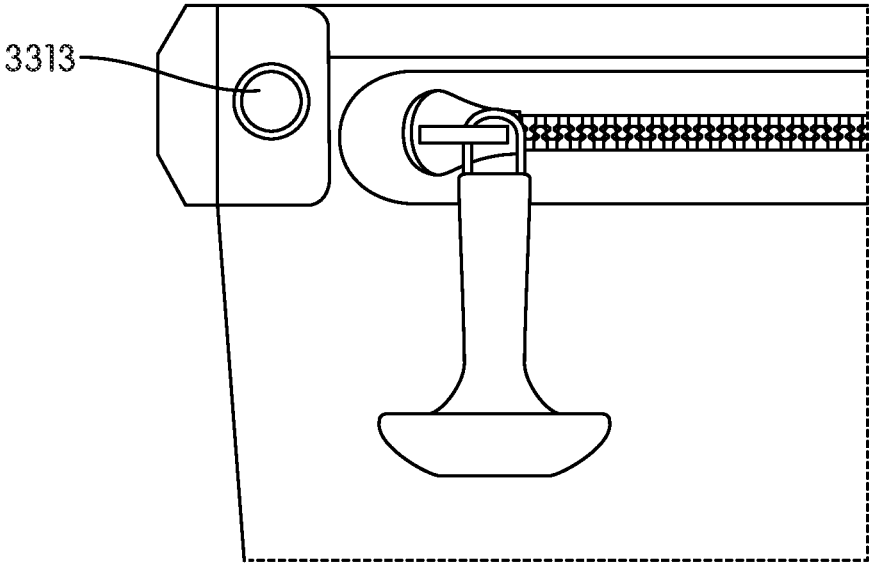

FIG. 16A

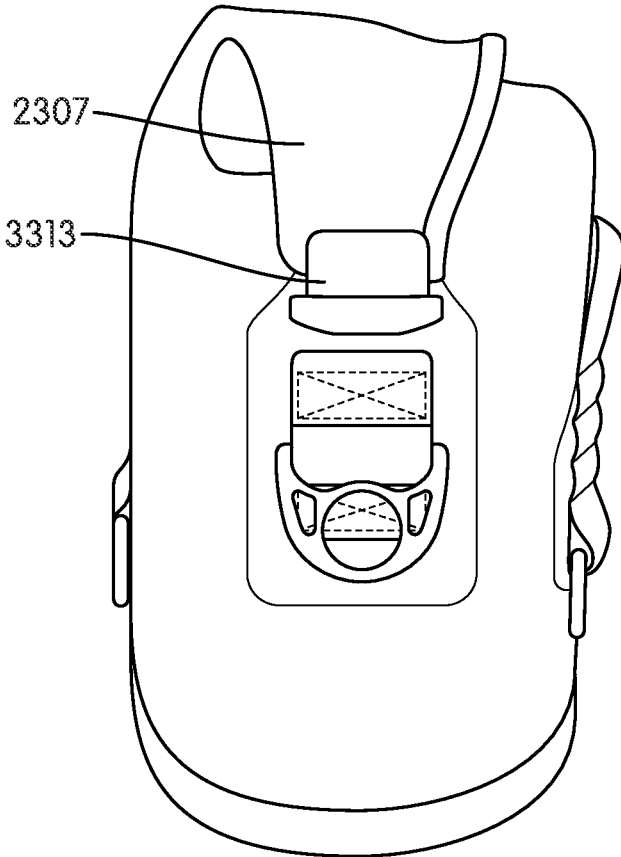

FIG. 16B

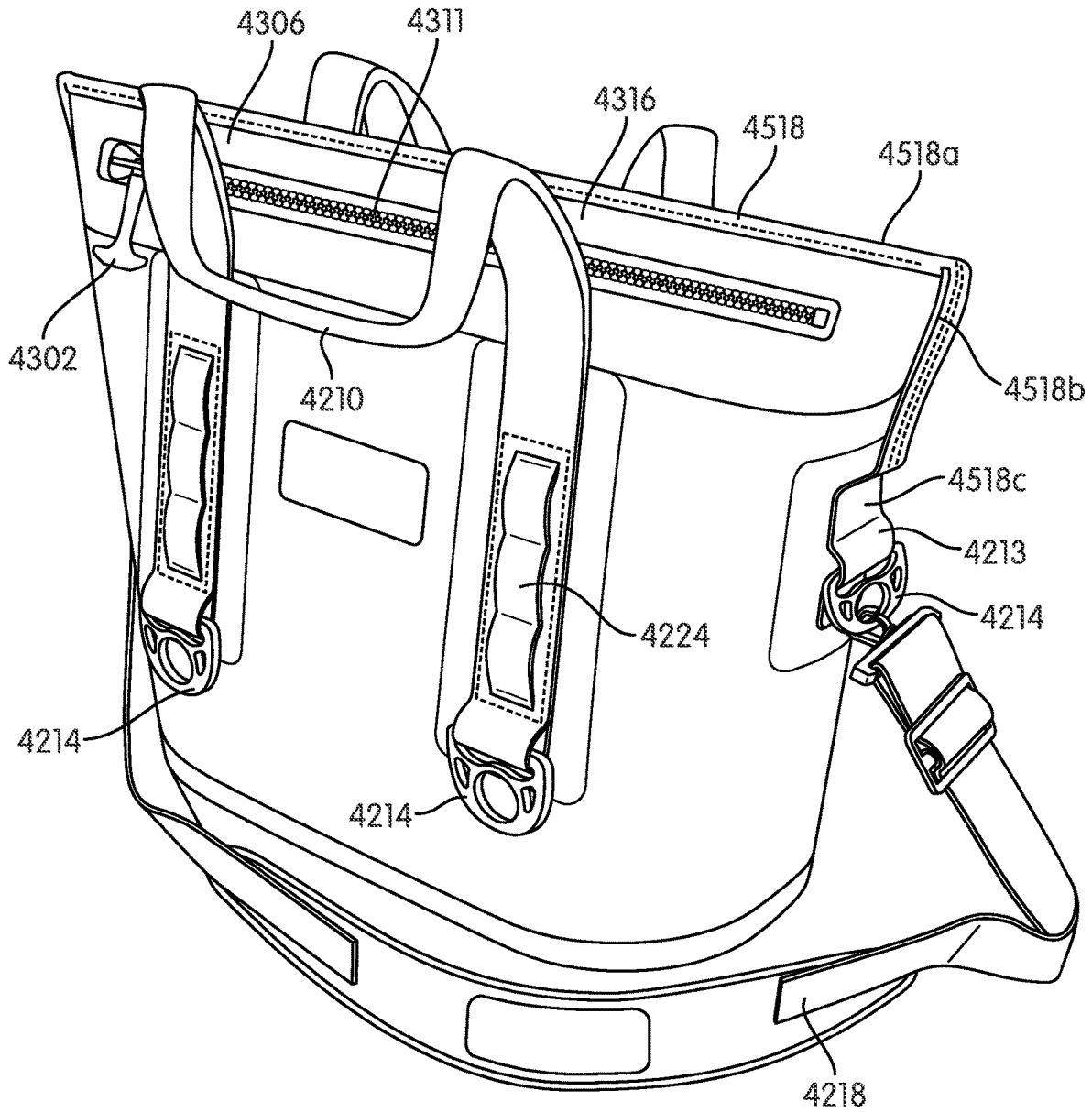

FIG. 17

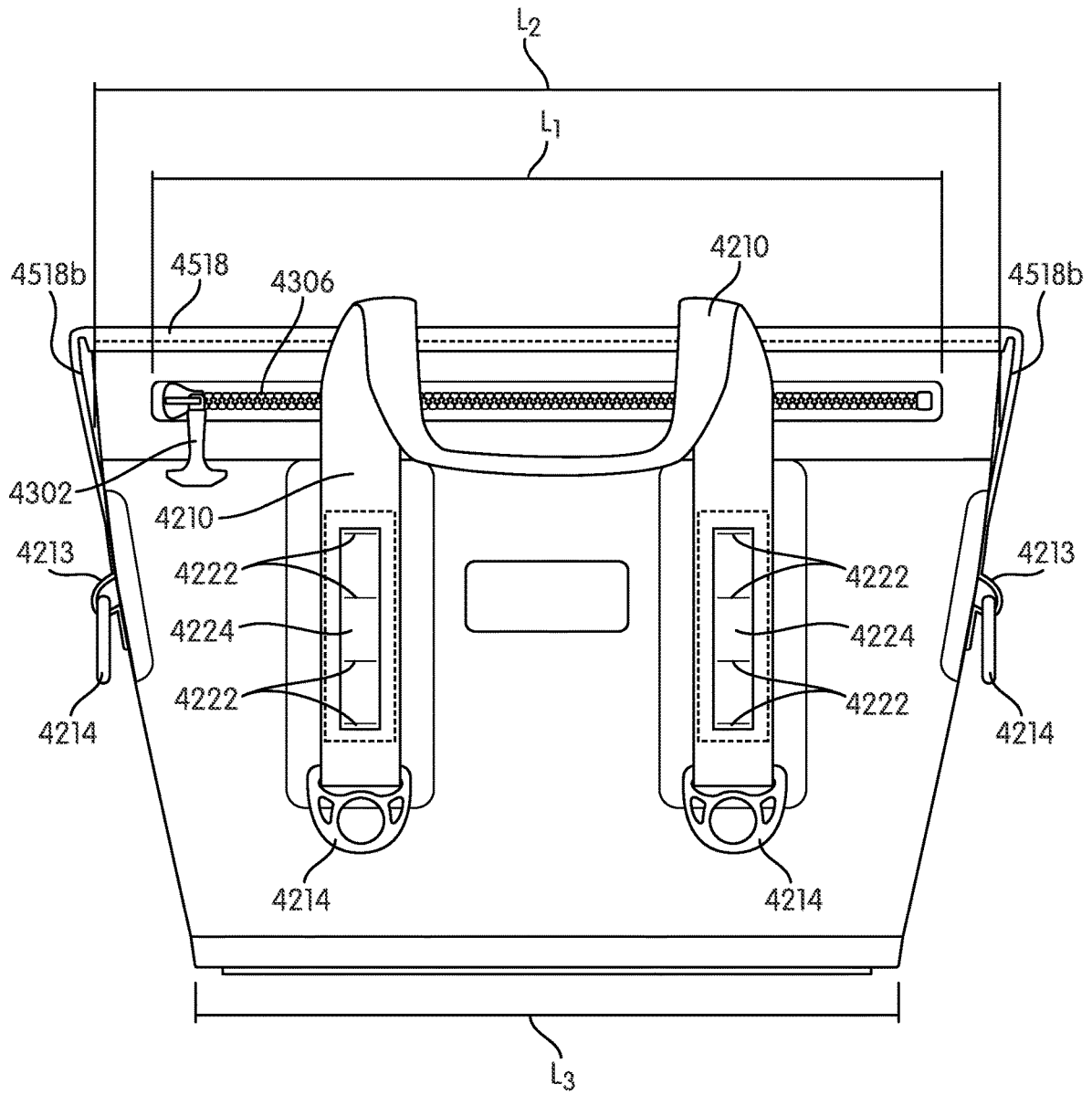

FIG. 18

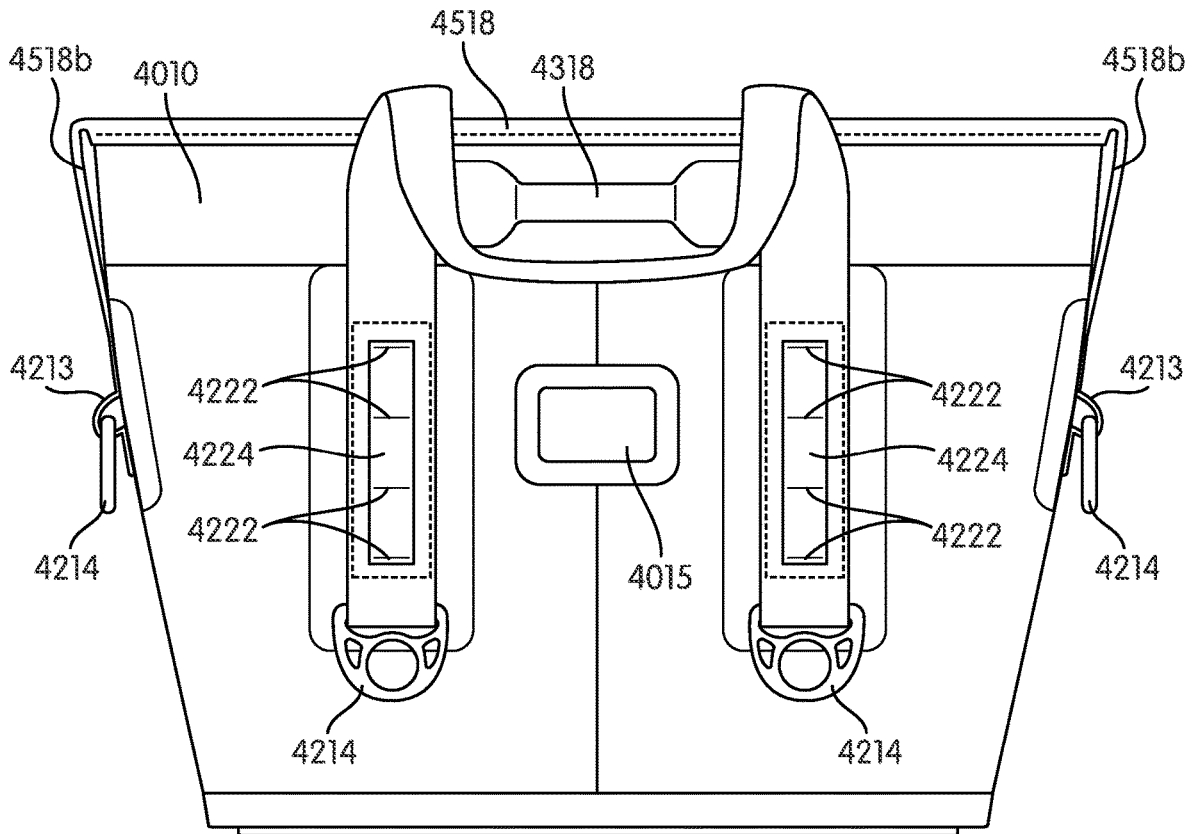

FIG. 19

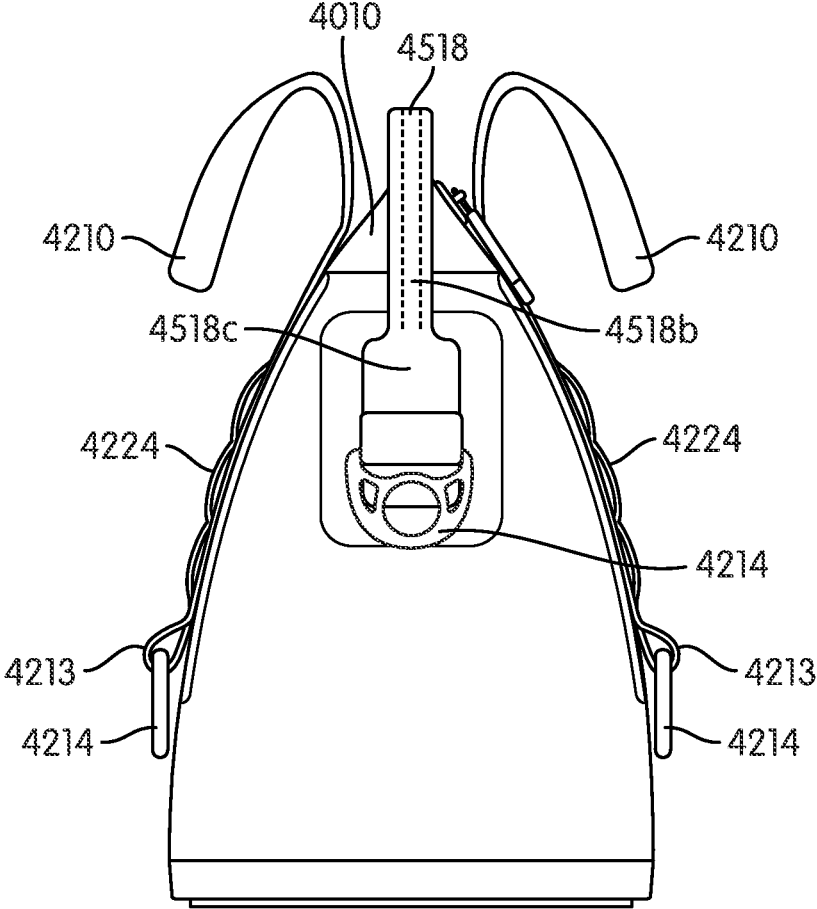

FIG. 20

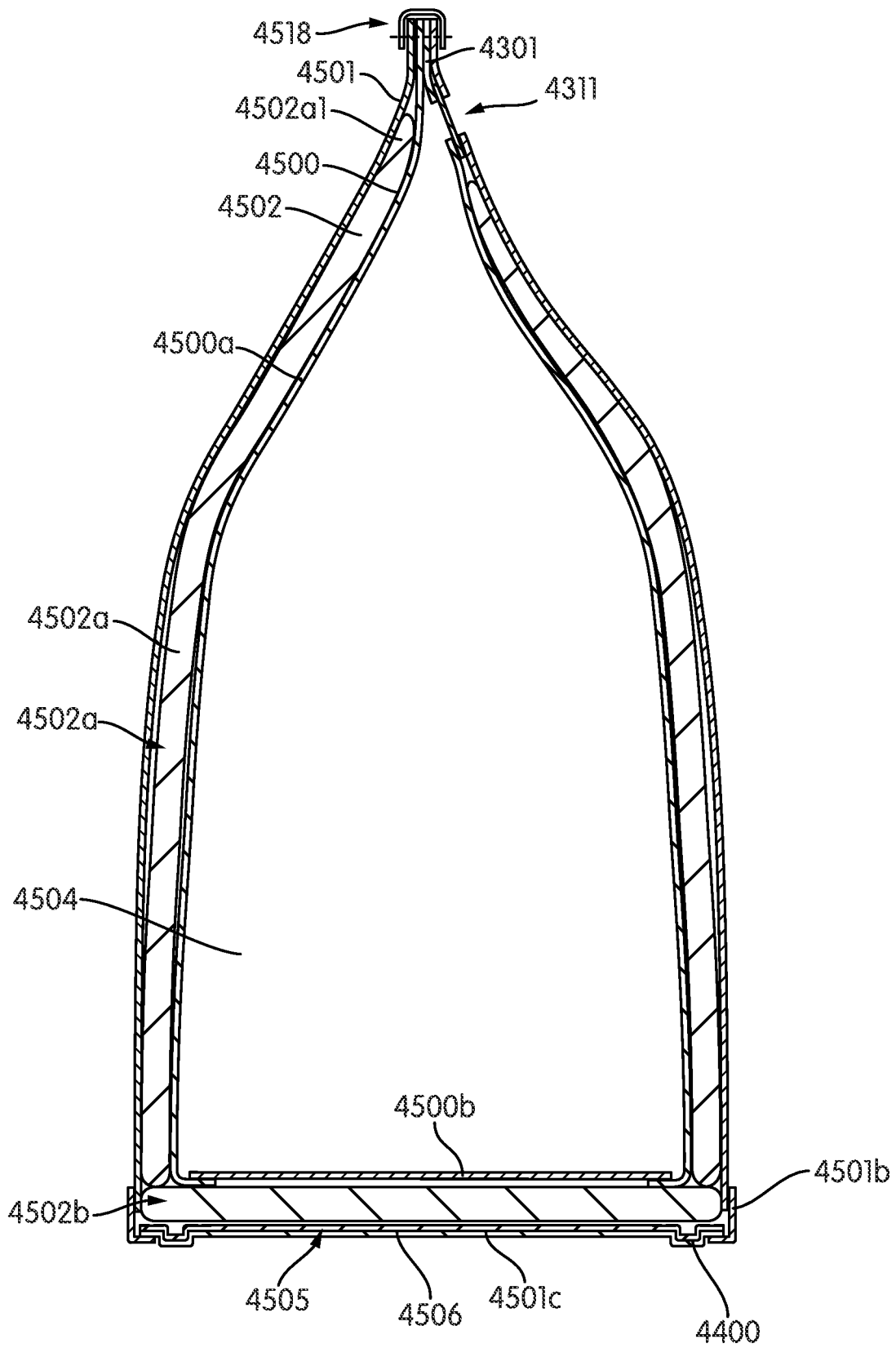

FIG. 21

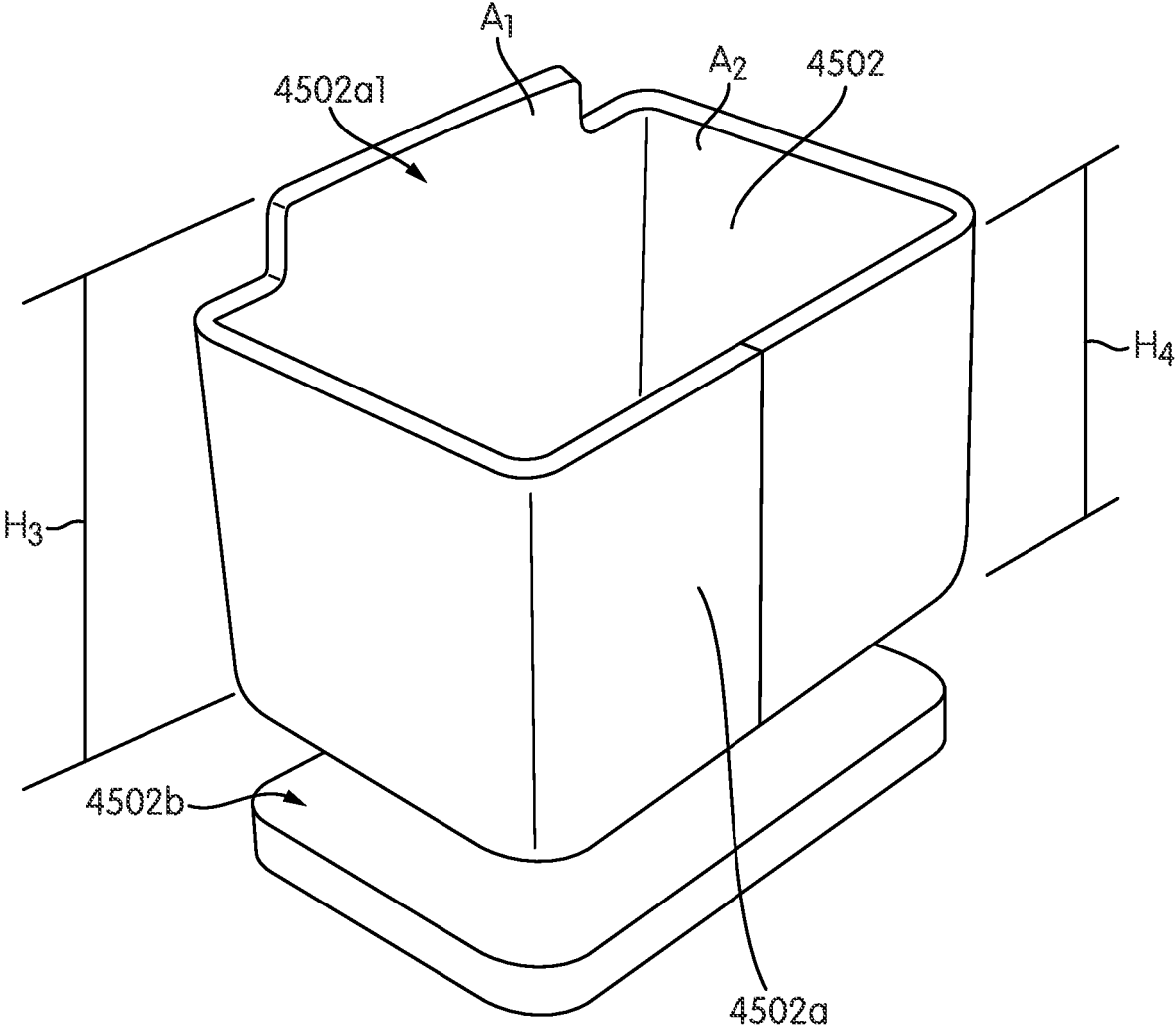

FIG. 22

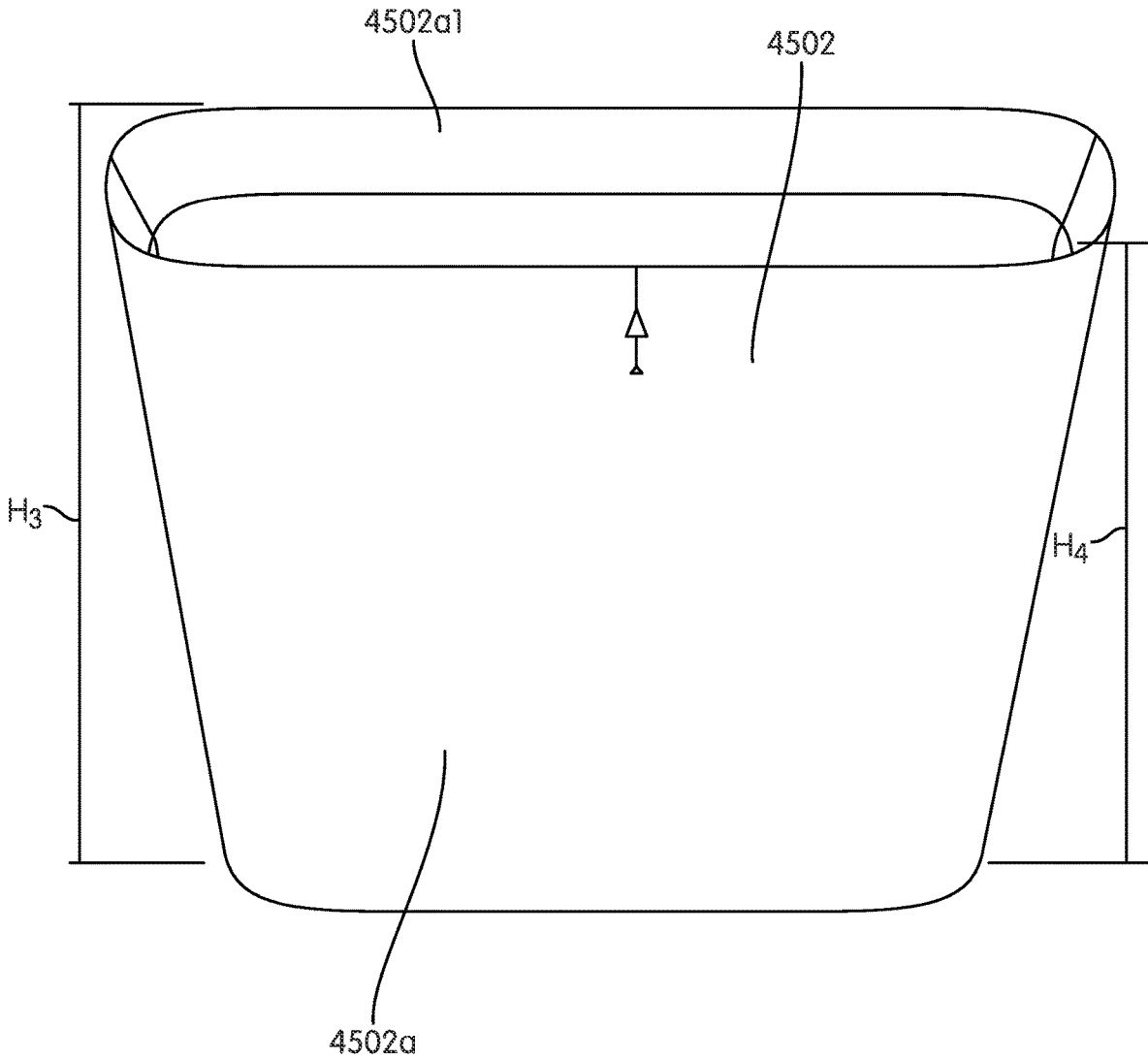

FIG. 22A

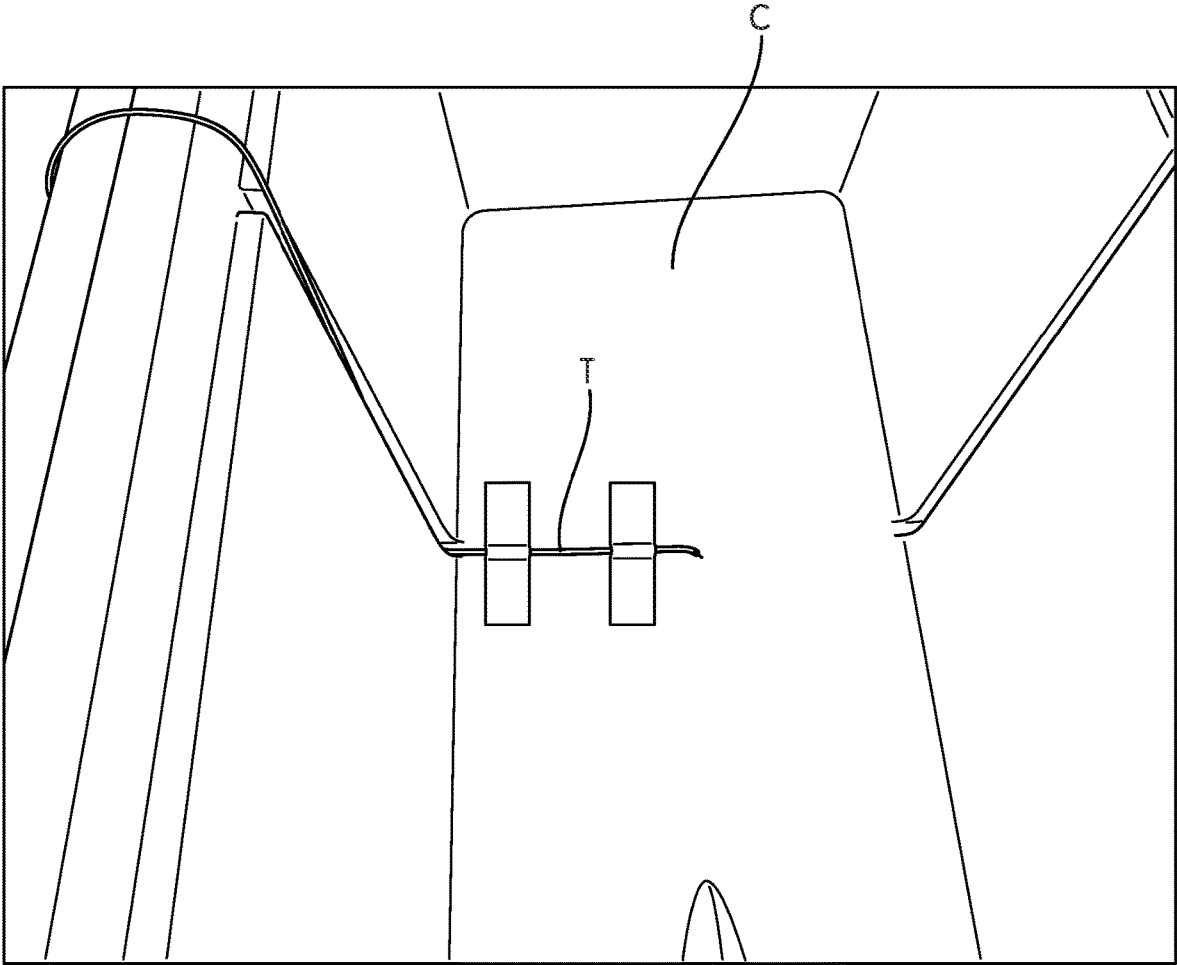

FIG. 23

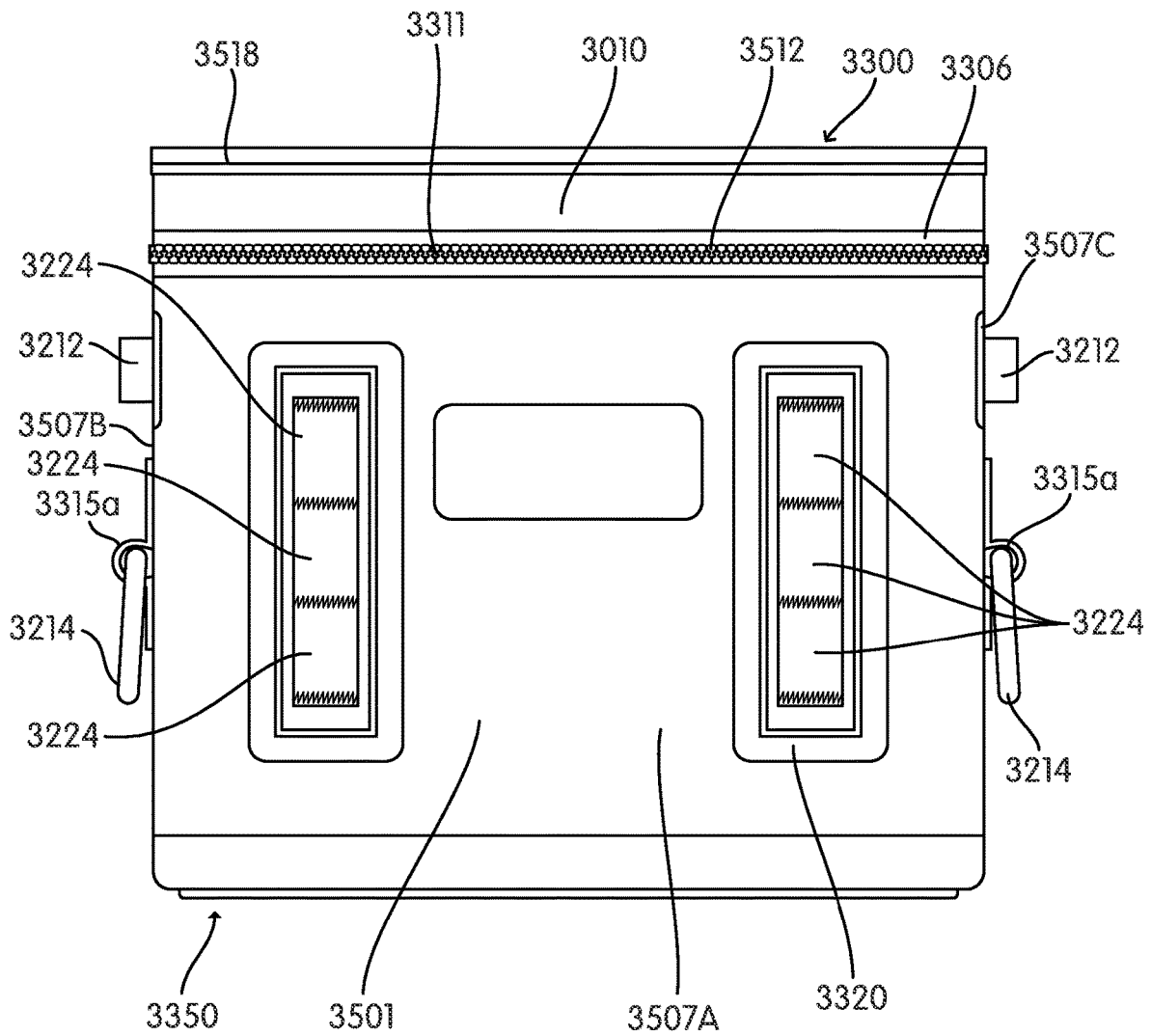

FIG. 24

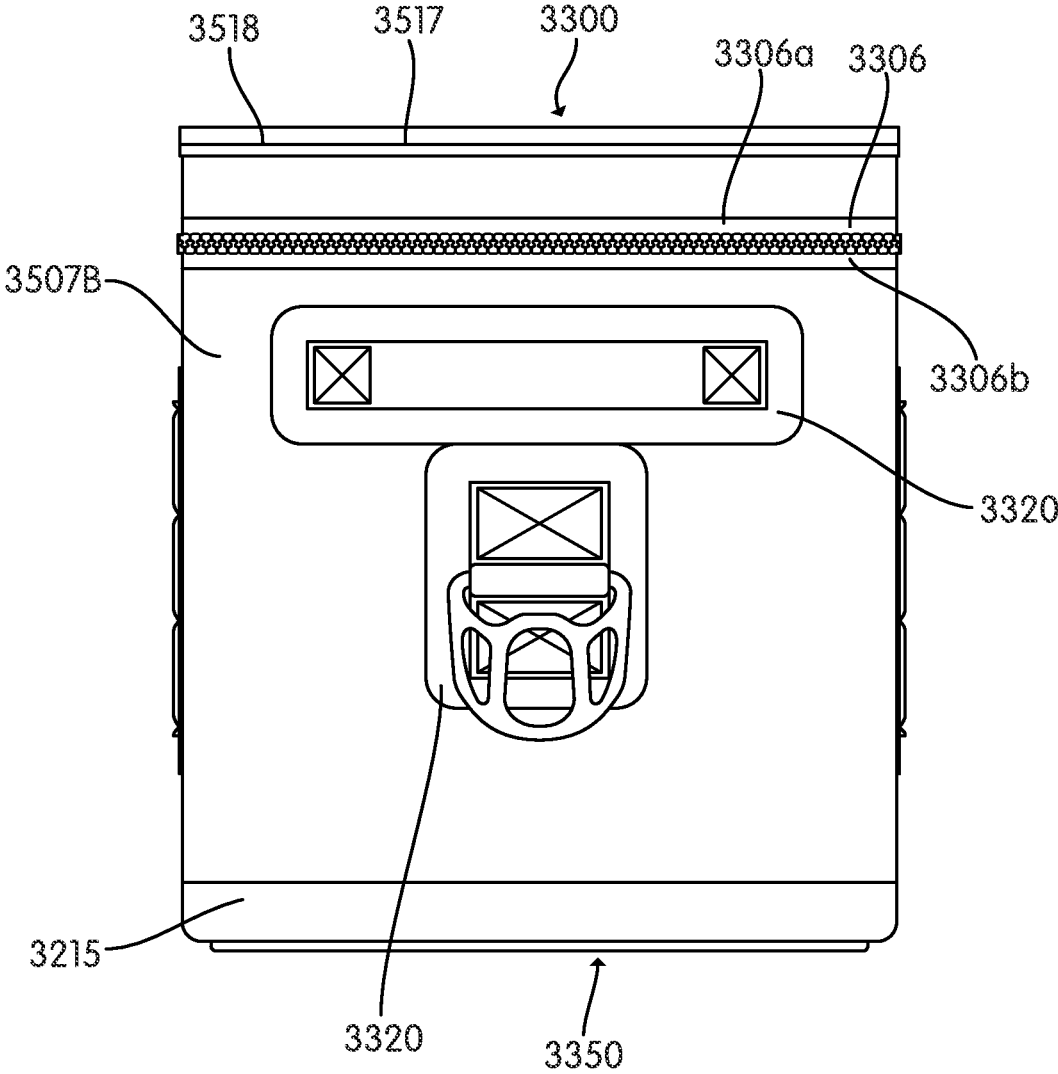

FIG. 25

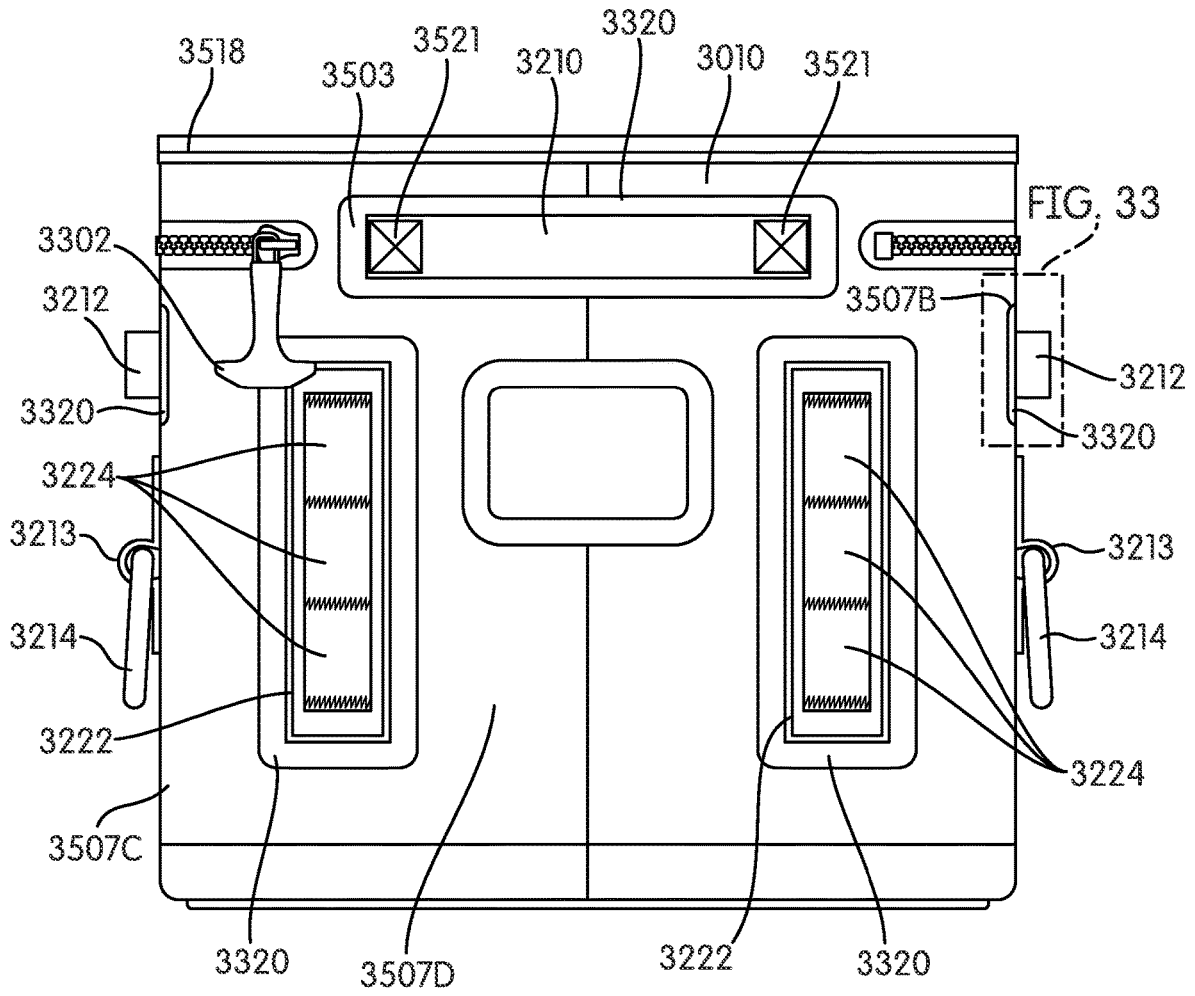

FIG. 26

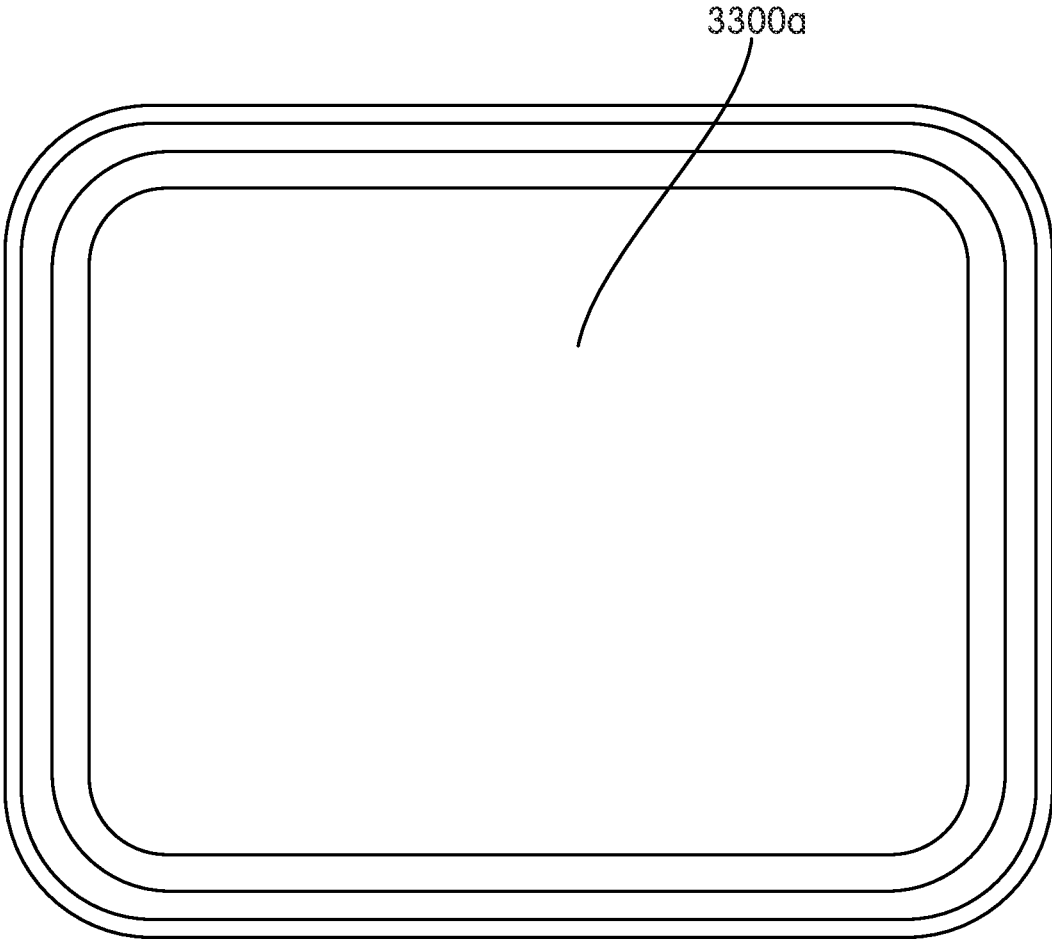

FIG. 27

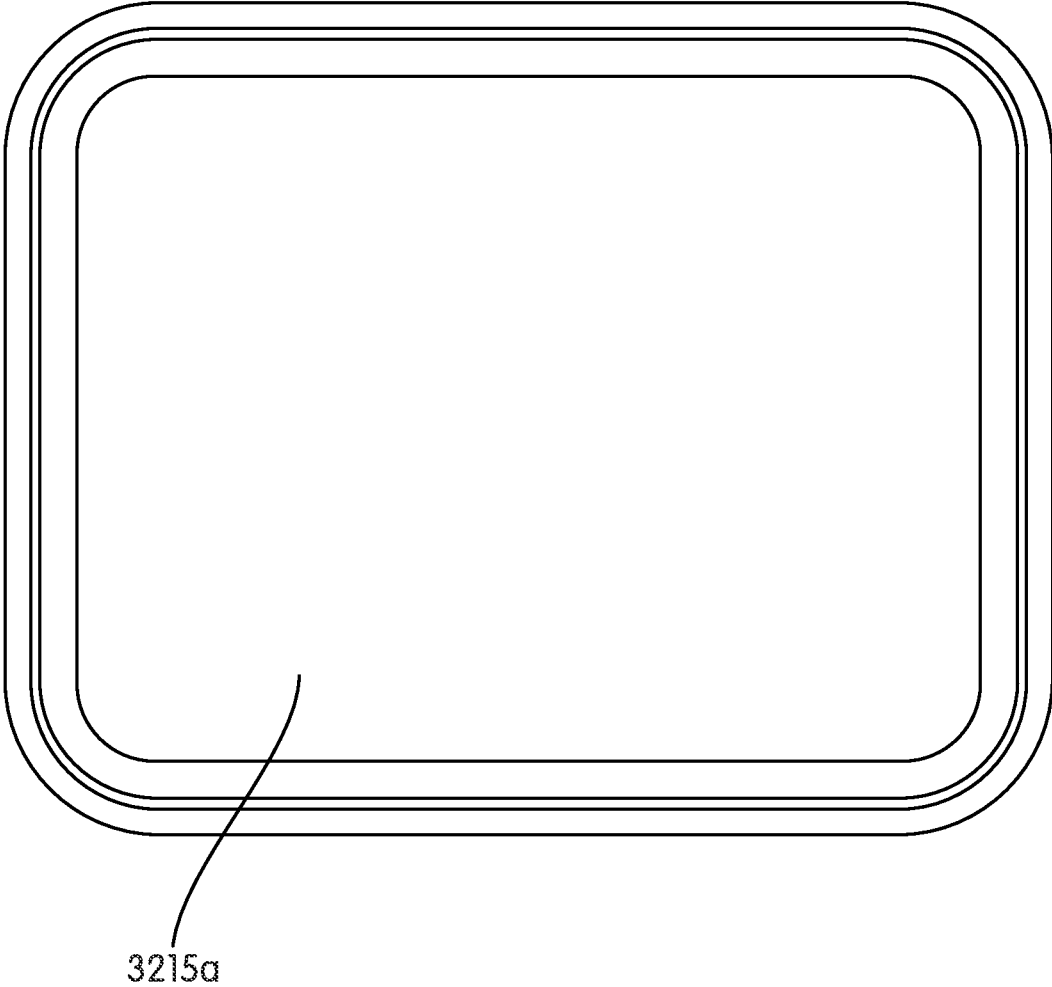

FIG. 28

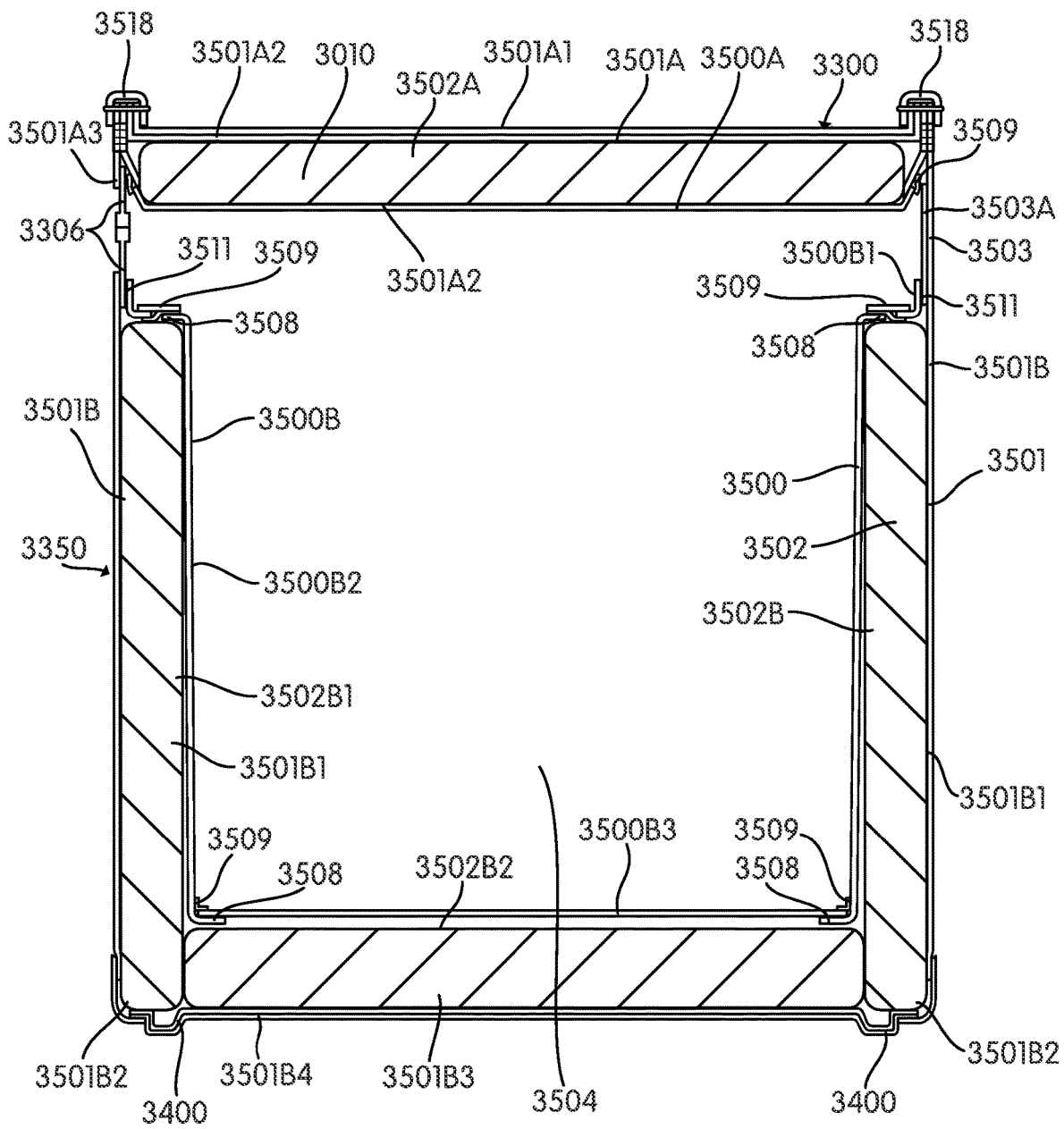

FIG. 29A

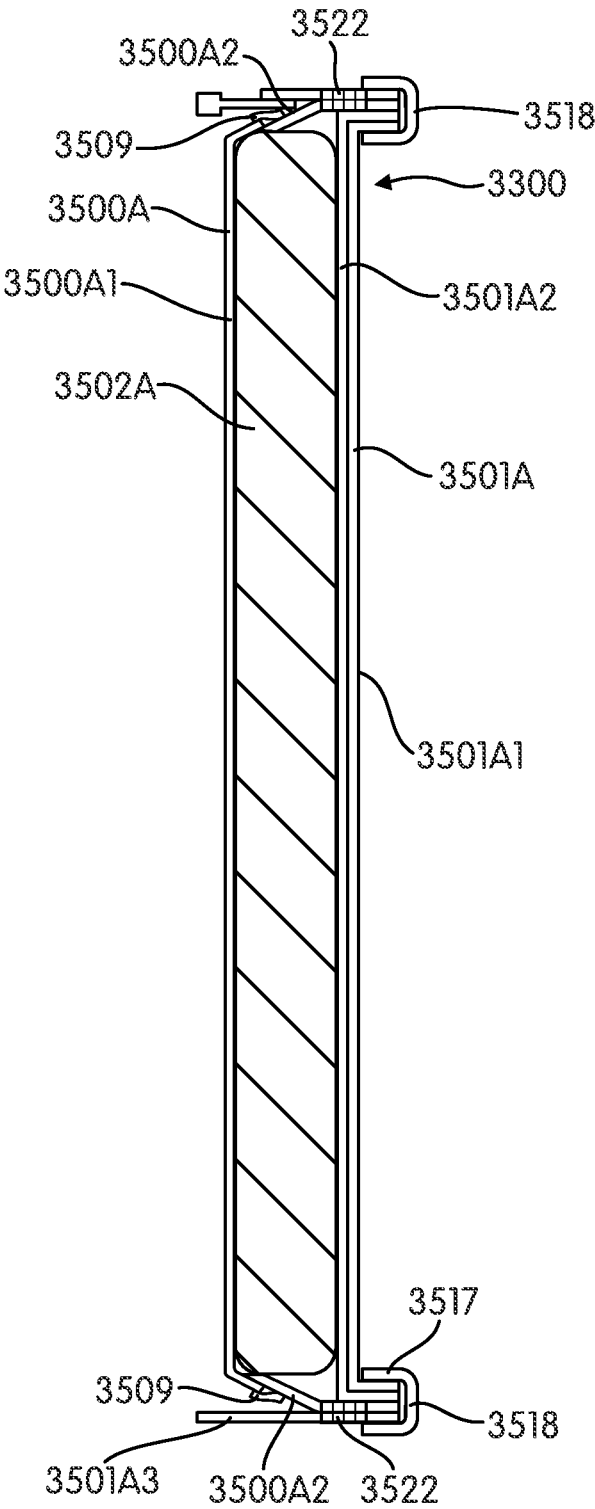

FIG. 29B

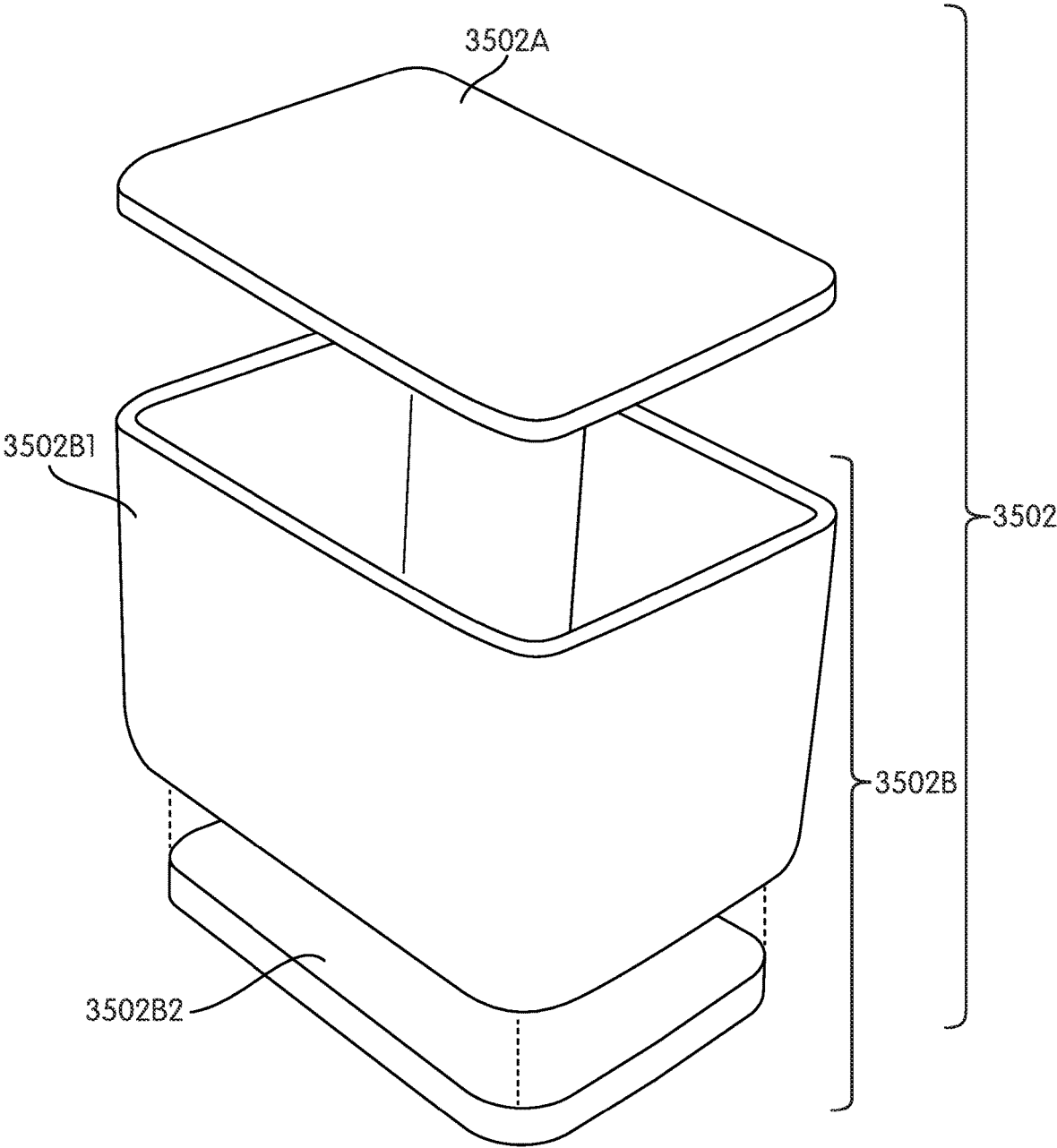

FIG. 30

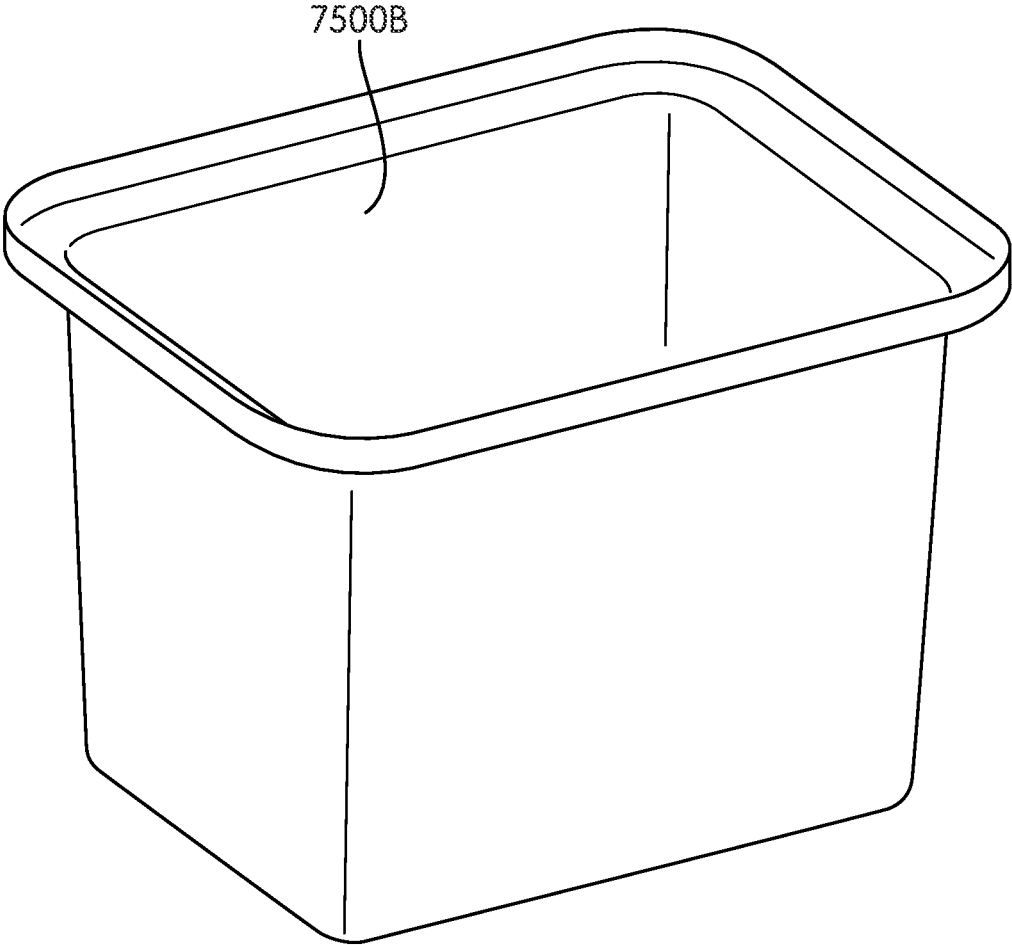

FIG. 31

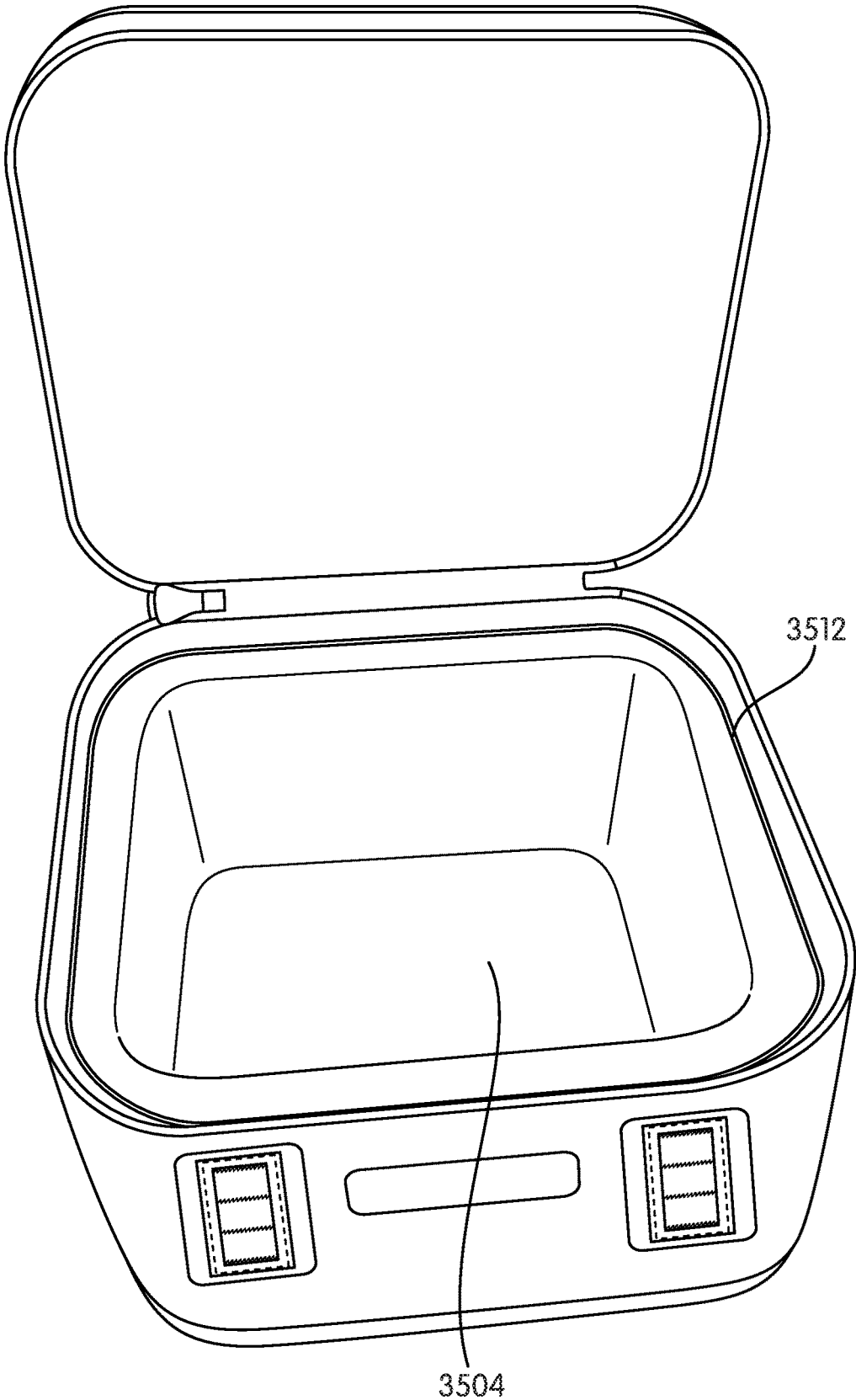

FIG. 32

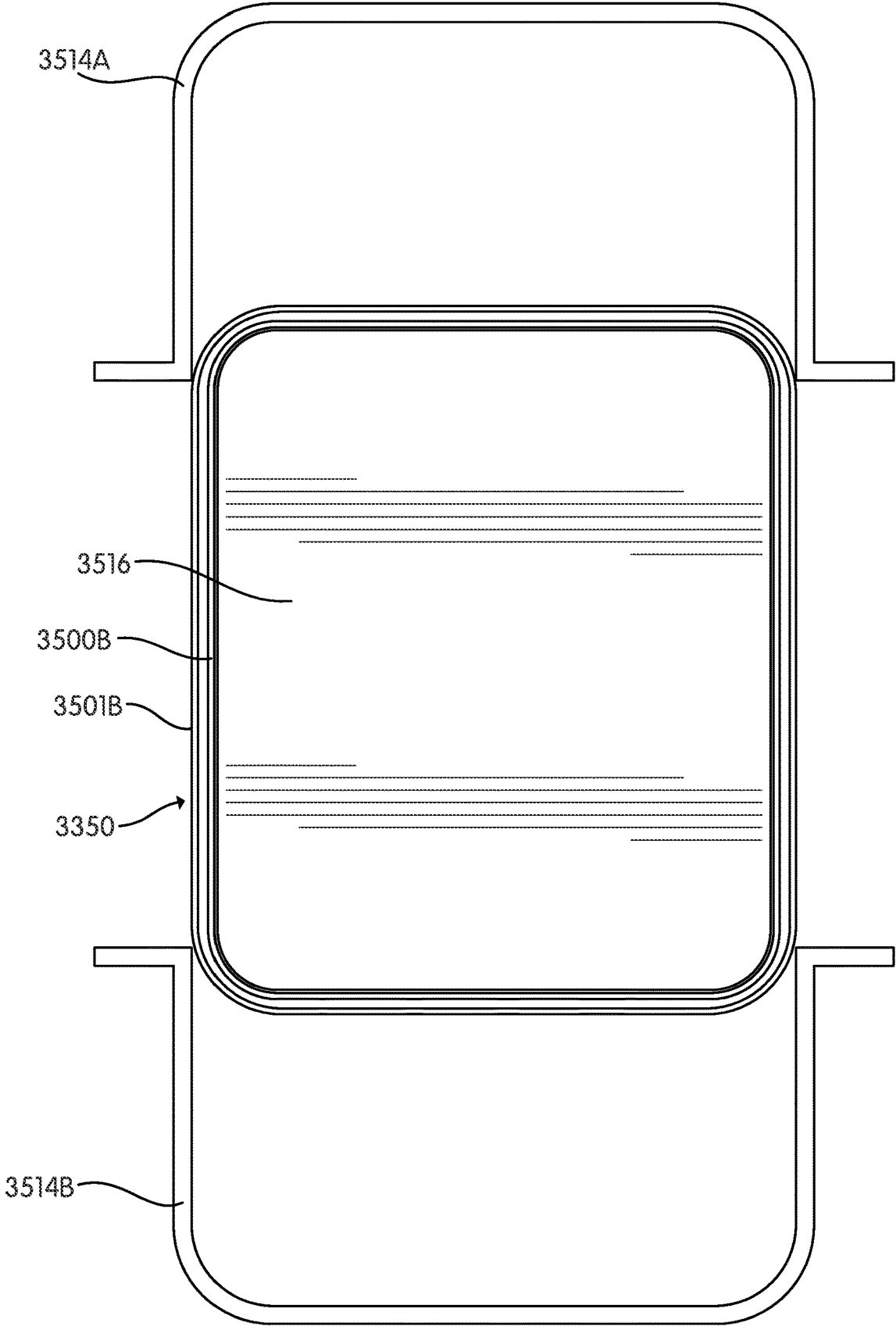

FIG. 32A

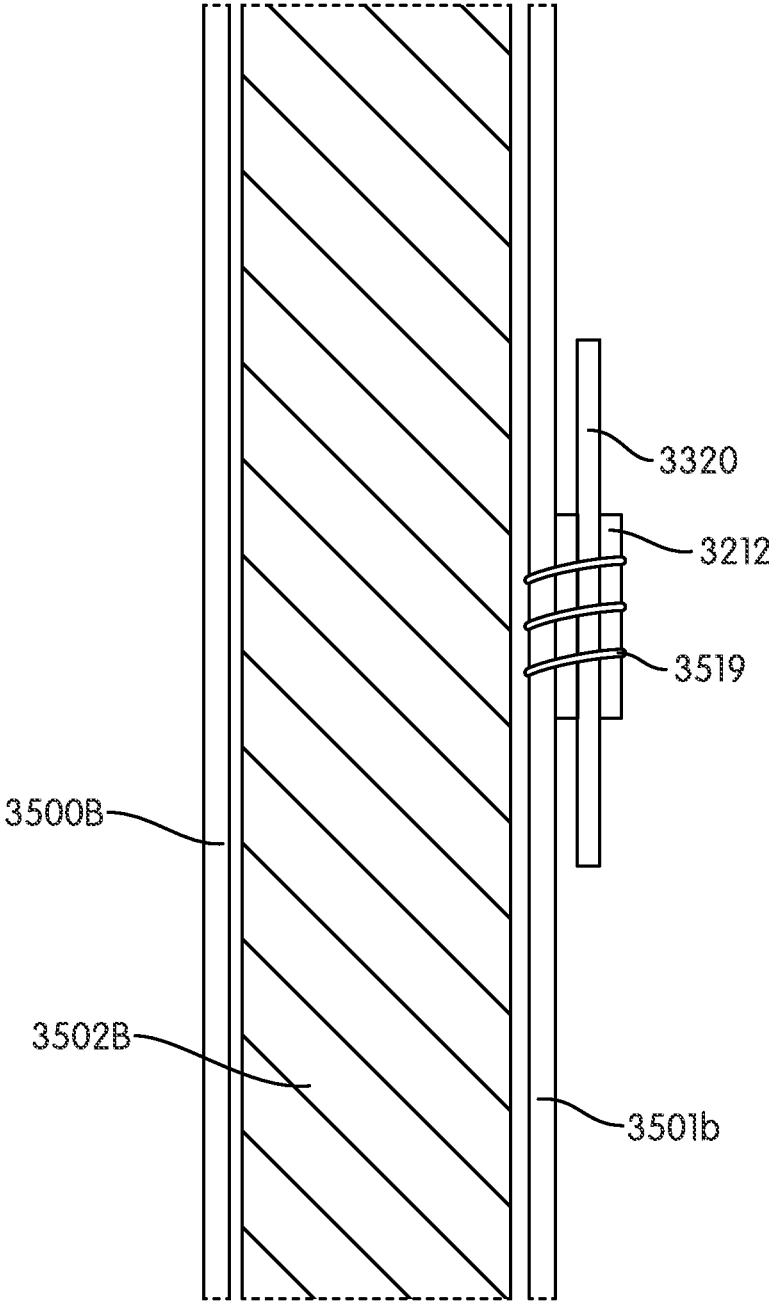

FIG. 33

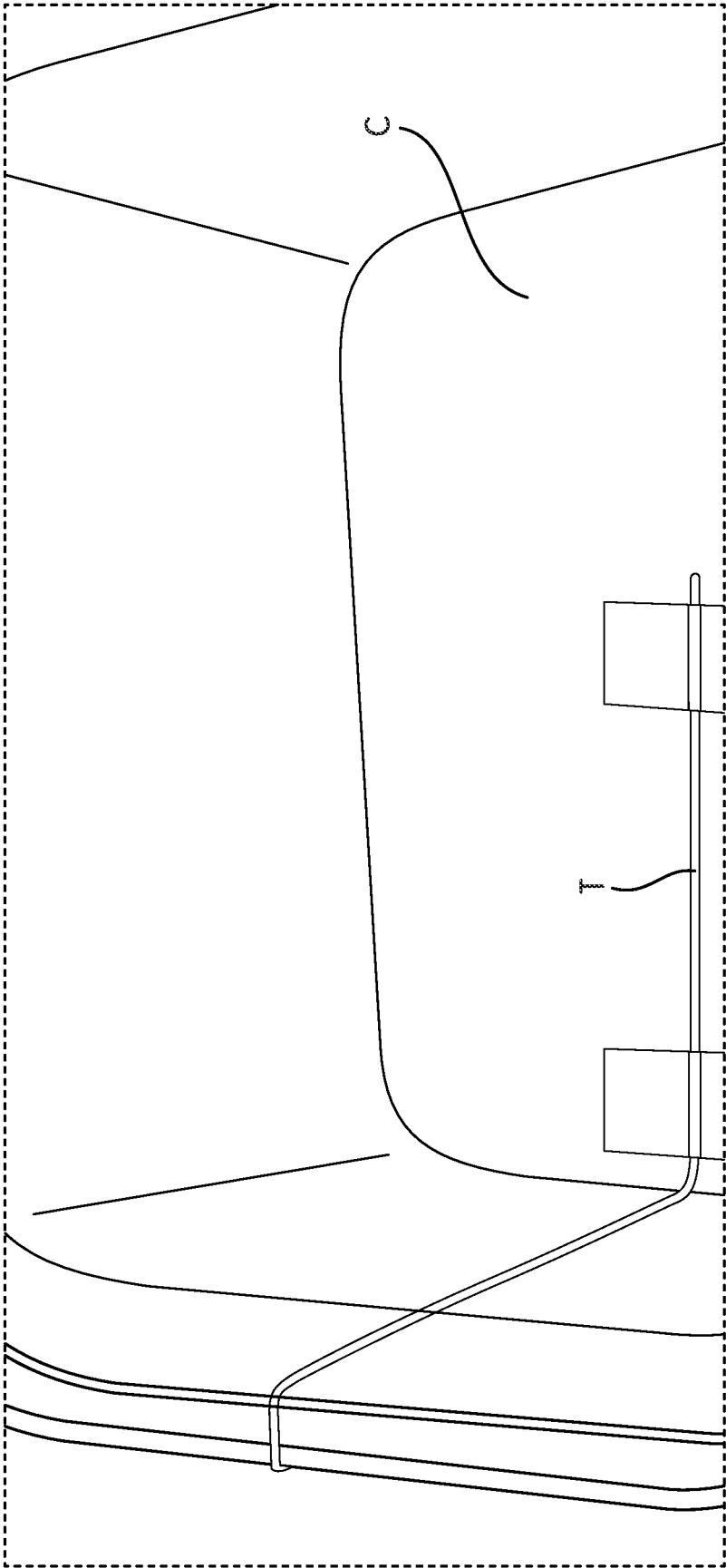

FIG. 34

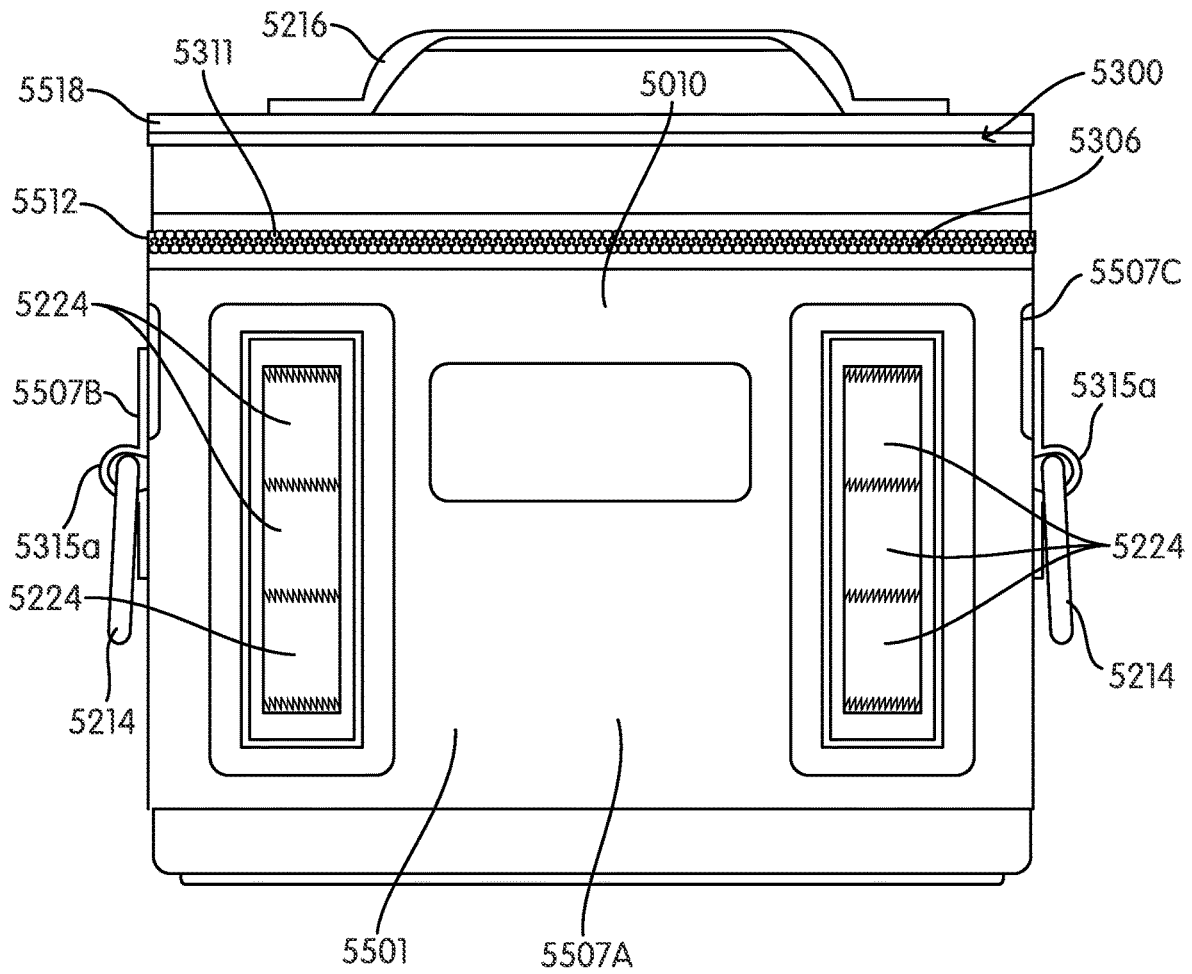

FIG. 35A

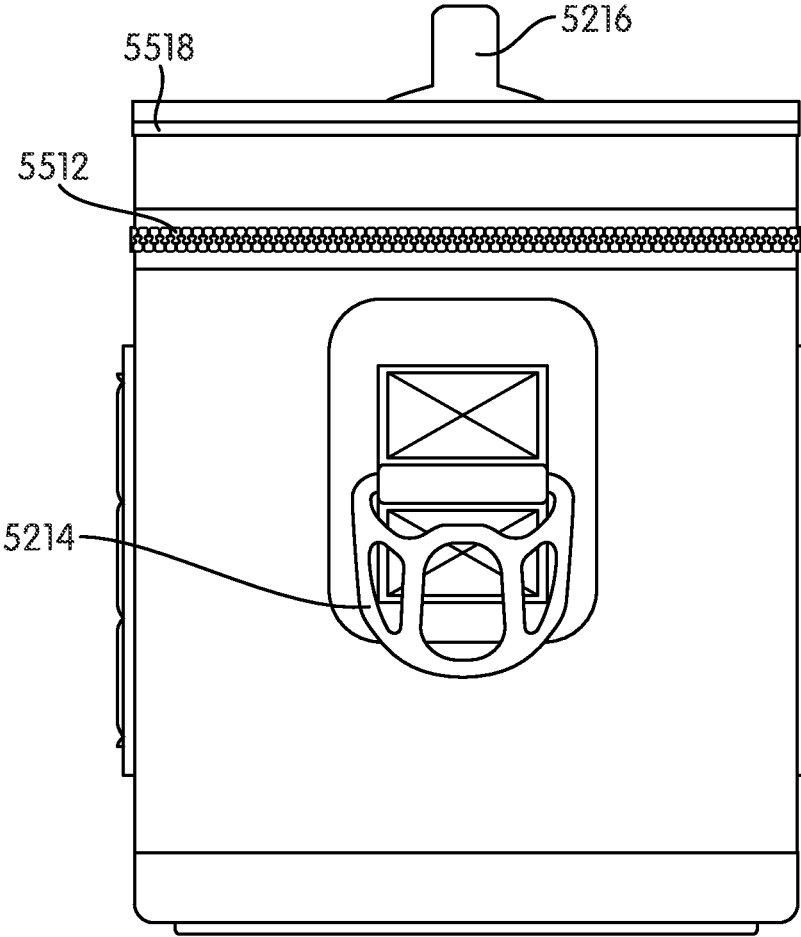

FIG. 35B

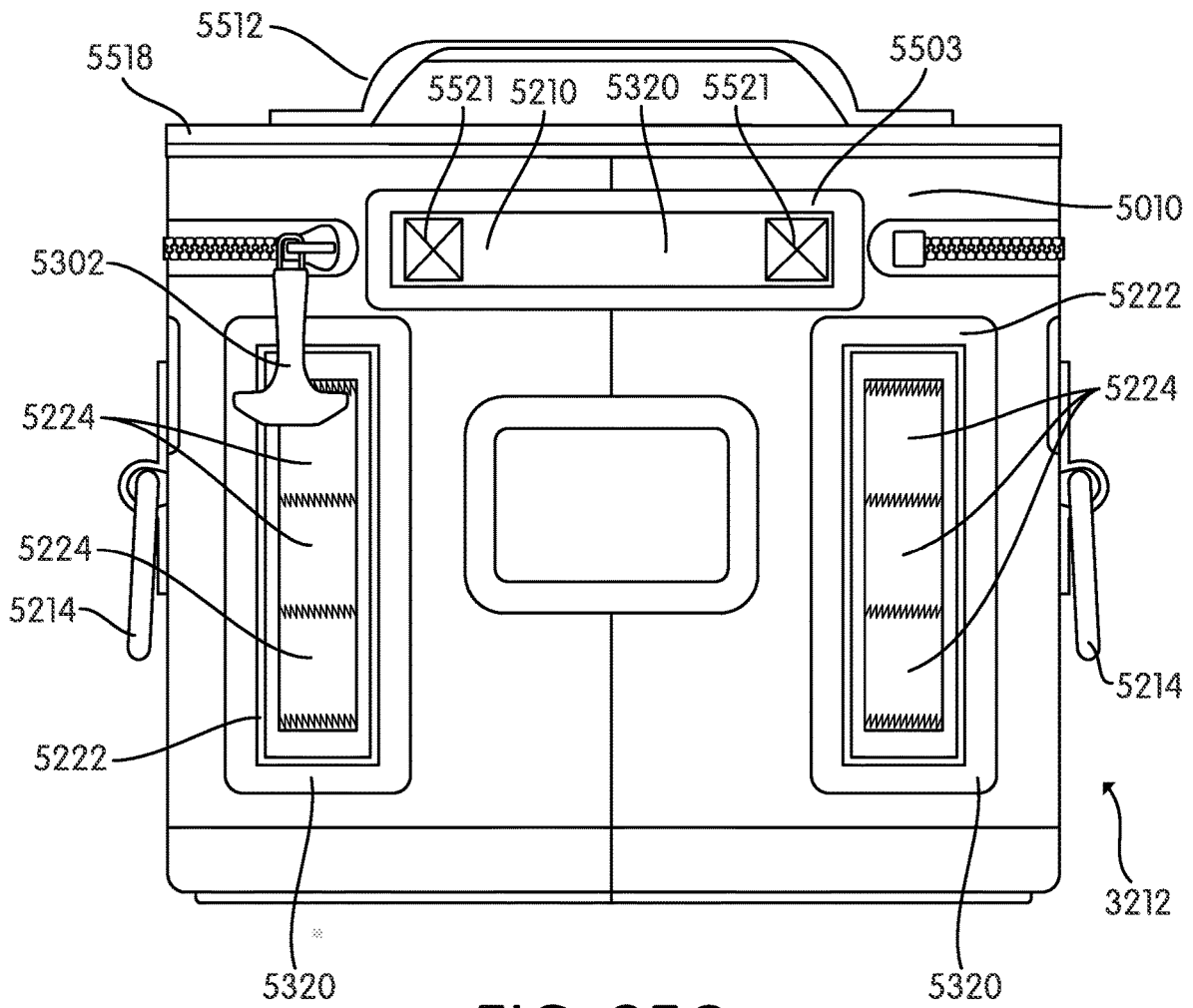

FIG. 35C

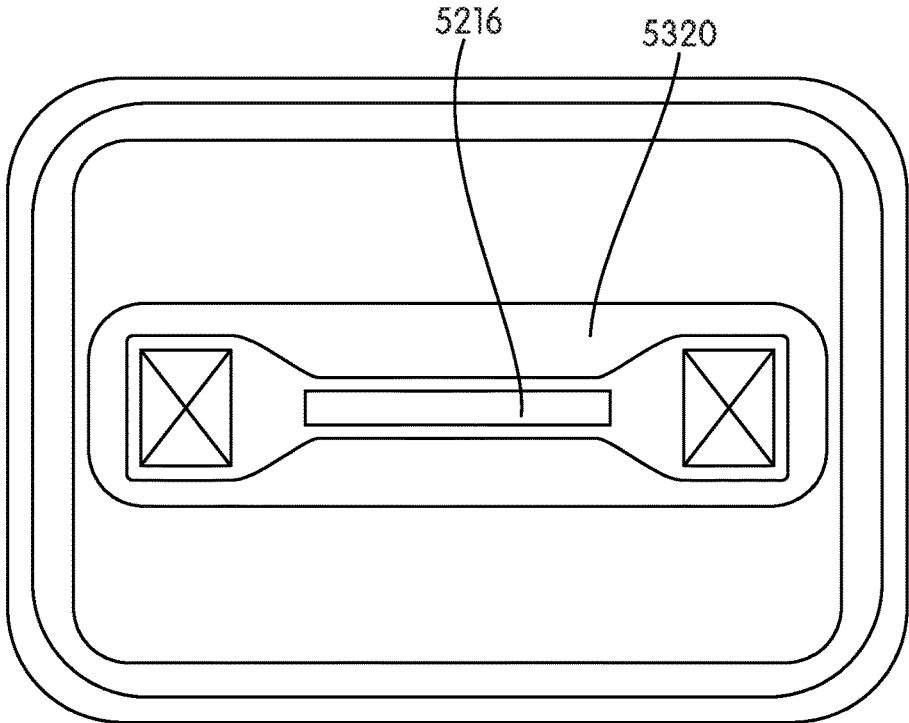

FIG. 35D

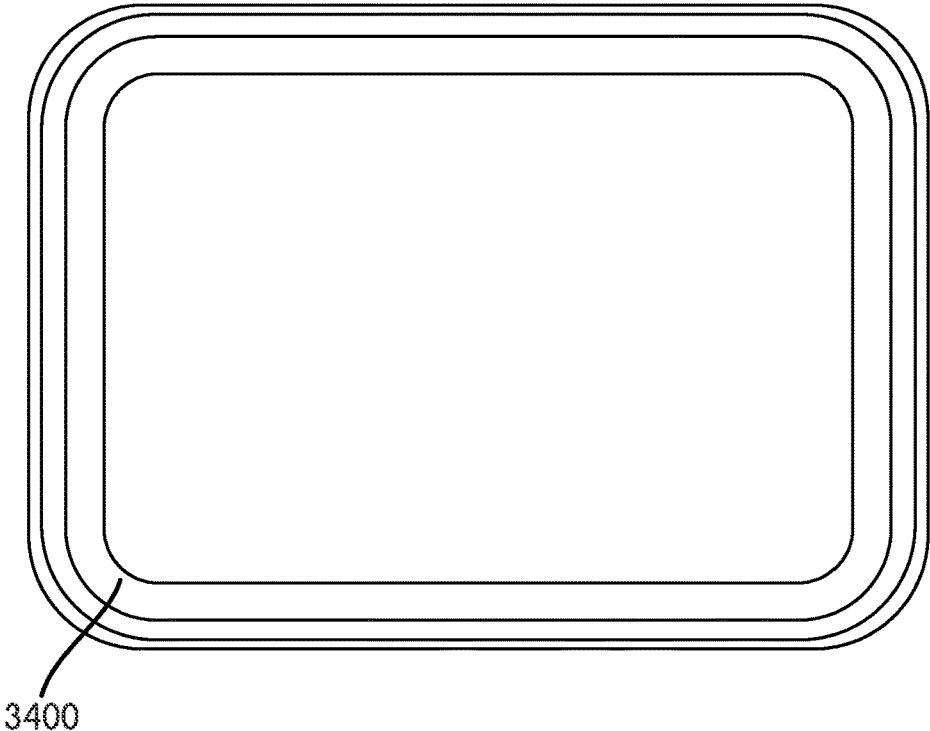

FIG. 35E

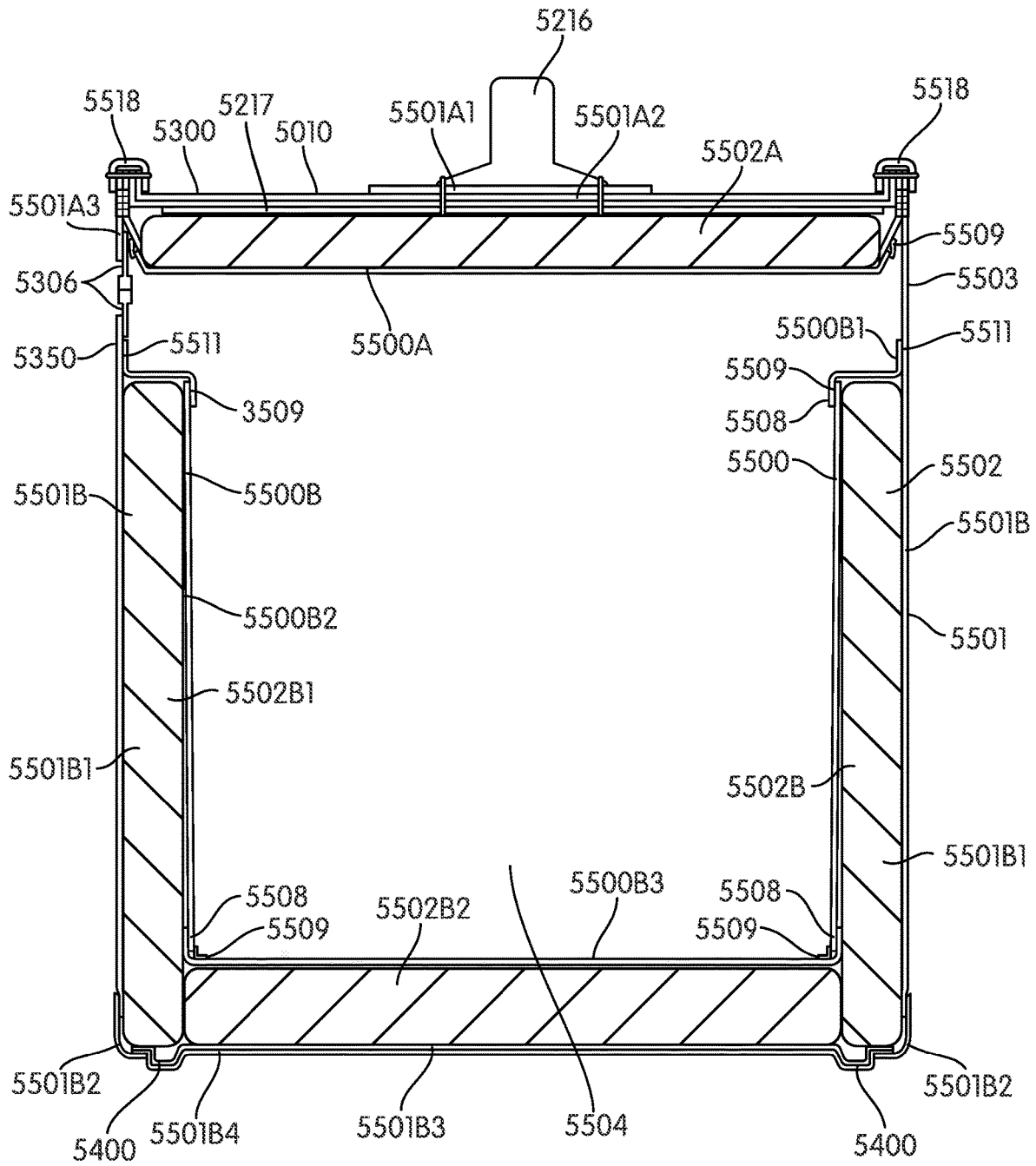

FIG. 35F

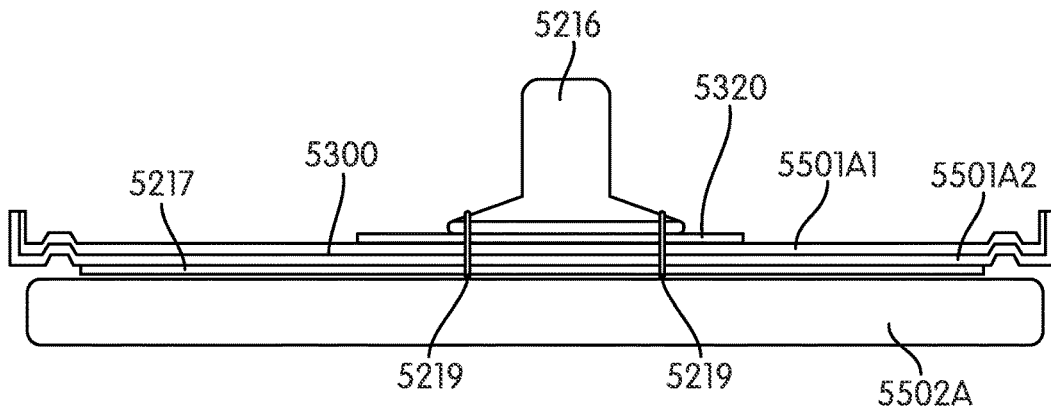

FIG. 36A

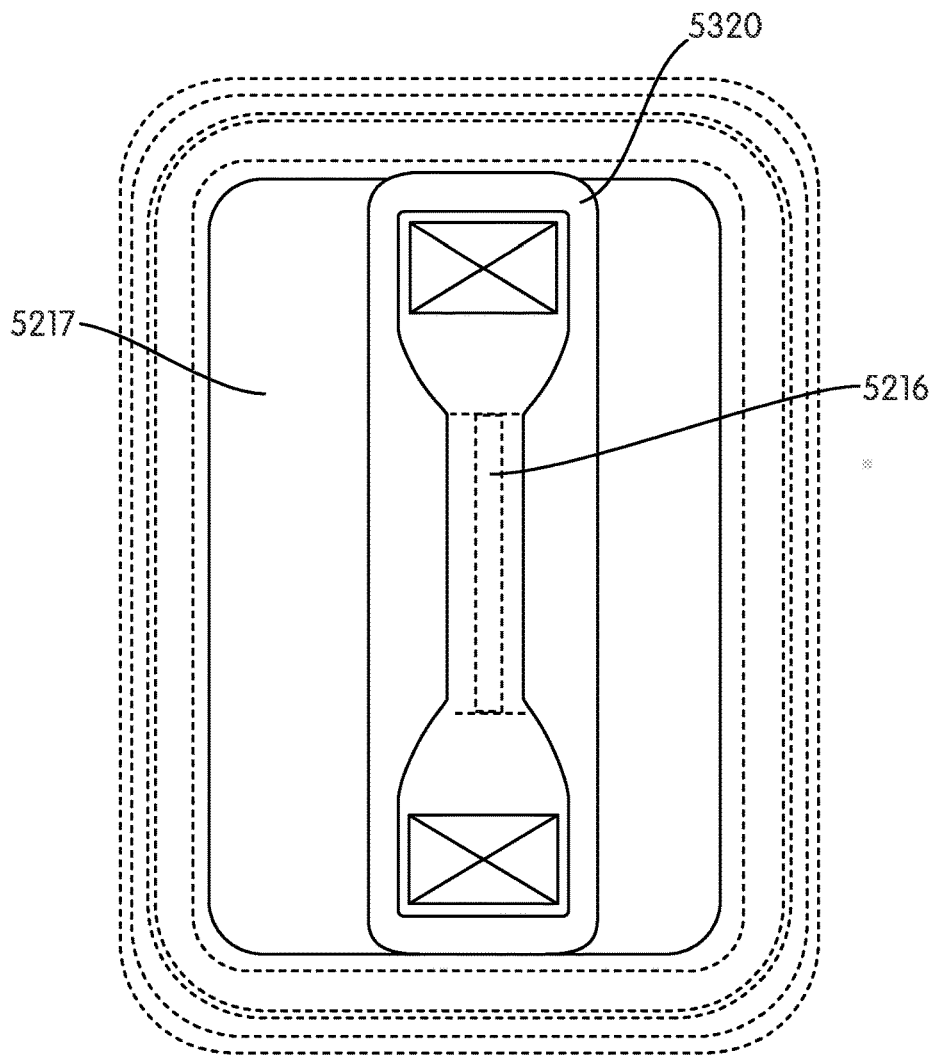

FIG. 36B

INSULATING DEVICE AND METHOD FOR FORMING INSULATING DEVICE

This application is a continuation of U.S. application Ser. No. 16/545,008, filed Aug. 20, 2019, which is a continuation of U.S. application Ser. No. 15/261,407, filed Sep. 9, 2016, now U.S. Pat. No. 10,384,855, which is a continuation-in-part of U.S. application Ser. No. 15/154,626, filed on May 13, 2016, now U.S. Pat. No. 10,029,842, which is a continuation-in-part of U.S. application Ser. No. 14/831,641, filed on Aug. 20, 2015, now U.S. Pat. No. 9,796,517, which is a divisional application of U.S. application Ser. No. 14/479,607, filed on Sep. 8, 2014, now U.S. Pat. No. 9,139,352, which claims priority to U.S. Application No. 61/937,310 filed on Feb. 7, 2014. This application also claims priority to U.S. Application No. 62/292,024 filed on Feb. 5, 2016, U.S. Application No. 62/299,421 filed on Feb. 24, 2016, and U.S. Application No. 62/299,402 filed on Feb. 24, 2016. All of the above applications are incorporated fully herein by reference.

FIELD

The present disclosure relates generally to non-rigid, portable, insulated devices or containers useful for keeping food and beverages cool or warm, and, more particularly, an insulating device with a waterproof closure.

1.0 BACKGROUND

Coolers are designed to keep food and beverages at lower temperatures. Containers may be composed of rigid materials such as metal or plastics or flexible materials such as fabric or foams. Coolers can be designed to promote portability. For example, rigid containers can be designed to incorporate wheels that facilitate ease of transport or coolers can be designed in smaller shapes to allow individuals to carry the entire device. Non-rigid containers can be provided with straps and/or handles and may in certain instances be made of lighter weight materials to facilitate mobility. Non-rigid coolers that maximize portability can be designed with an aperture on the top that allows access to the interior contents of the cooler. The aperture can also be provided with a closure.

2.0 SUMMARY

This Summary provides an introduction to some general concepts relating to this invention in a simplified form that are further described below in the Detailed Description. This Summary is not intended to identify key features or essential features of the invention.

Aspects of the disclosure herein may relate to insulating devices having one or more of (1) a waterproof closure (2) an outer shell, (3) an inner liner, (4) an insulating layer floating freely in between the outer shell and the inner liner, or (5) a waterproof storage compartment.

3.0 BRIEF DESCRIPTION OF THE DRAWINGS

The foregoing Summary, as well as the following Detailed Description, will be better understood when considered in conjunction with the accompanying drawings in which like reference numerals refer to the same or similar elements in all of the various views in which that reference number appears.

FIG. 1A shows a left front perspective view of an example insulating device in accordance with an aspect of the disclosure;

FIG. 1B shows a frontside perspective view of the example insulating device of FIG. 1A without the shoulder strap;

FIG. 2 shows a backside perspective view of the example insulating device of FIG. 1A without the shoulder strap;

FIG. 3A shows a top perspective view of the example insulating device of FIG. 1A without the shoulder strap;

FIG. 3B shows a top view of a portion of the example insulating device of FIG. 1A;

FIG. 3C shows a portion of an alternate top perspective view of the example insulating device of FIG. 1A;

FIG. 4 shows a bottom perspective view of the example insulating device of FIG. 1A;

FIG. 5A illustrates a schematic of a cross-sectional view of the example insulating device of FIG. 1A;

FIG. 5B illustrates another schematic of an enlarged portion of a cross-sectional view of the example insulating device of FIG. 1A;

FIG. 6 illustrates an exemplary process flow diagram for forming an insulating device;

FIGS. 7A-7J illustrate exemplary methods of forming an insulating device;

FIGS. 8A and 8B depict perspective views of an alternative example insulating device.

FIG. 9 depicts a portion of an exemplary closure and an example test method for determining if an insulating device maintains the contents therein.

FIG. 10 depicts an example test for determining the strength of an insulating device.

FIG. 11 shows a front view of another exemplary insulating device.

FIG. 12 shows a side view of the exemplary insulating device of FIG. 11.

FIG. 13 shows a front perspective view of the exemplary insulating device in an alternate configuration.

FIG. 14A shows a side and cross-sectional view of the exemplary insulating device of FIG. 11.

FIG. 14B shows an enlarged section of FIG. 14A.

FIG. 15 shows a schematic exploded view of an exemplary insulation layer for the example insulating device of FIG. 11.

FIG. 16A shows a portion of another example insulating device.

FIG. 16B shows a side view of the example insulating device of FIG. 16A.

FIG. 17 shows a perspective view of another example insulating device.

FIG. 18 shows a front view of the insulating device of FIG. 17.

FIG. 19 shows a rear view of the insulating device of FIG. 17.

FIG. 20 shows a side view of the insulating device of FIG. 17.

FIG. 21 shows a cross-sectional view of the insulating device of FIG. 17.

FIG. 22 shows a schematic exploded view of an exemplary insulation layer for the example insulating device of FIG. 17.

FIG. 22A shows a front view of an exemplary insulation layer for the example insulating device of FIG. 17.

FIG. 23 illustrates an exemplary testing method.

FIG. 24 shows a front view of an example insulating device in accordance with an aspect of the disclosure;

FIG. 25 shows a side view of the example insulating device of FIG. 24.

FIG. 26 shows a rear view of the example insulating device of FIG. 24.

FIG. 27 shows a top view of the example insulating device of FIG. 24.

FIG. 28 shows a bottom view of the example insulating device of FIG. 24.

FIG. 29A shows a cross-sectional view of the example insulating device of FIG. 24.

FIG. 29B shows a portion of a cross-sectional view of the example insulating device of FIG. 24.

FIG. 30 shows an isometric view of an exemplary insulating layer of the example insulating device of FIG. 24.

FIG. 31 shows an alternative embodiment for an inner liner of an insulating device.

FIG. 32 shows the insulating device of FIG. 24 in the opened position.

FIG. 32A shows an example manufacturing method for forming an insulating device.

FIG. 33 shows an example method of securing a handle to an insulating device.

FIG. 34 illustrates an exemplary testing method.

FIG. 35A shows a front view of another exemplary insulating device.

FIG. 35B shows a side view of the exemplary insulating device of FIG. 35A.

FIG. 35C shows a rear view of the exemplary insulating device of FIG. 35A.

FIG. 35D shows a top view of the exemplary insulating device of FIG. 35A.

FIG. 35E shows a bottom view of the exemplary insulating device of FIG. 35A.

FIG. 35F shows a cross-sectional view of the exemplary insulating device of 35A.

FIG. 36A shows a partial cross-sectional view of an exemplary lid.

FIG. 36B shows a transparent top view of the exemplary lid of FIG. 36A.

4.0 DETAILED DESCRIPTION

In the following description of the various examples and components of this disclosure, reference is made to the accompanying drawings, which form a part hereof, and in which are shown by way of illustration various example structures and environments in which aspects of the disclosure may be practiced. It is to be understood that other structures and environments may be utilized and that structural and functional modifications may be made from the specifically described structures and methods without departing from the scope of the present disclosure.

Also, while the terms “frontside,” “backside,” “top,” “base,” “bottom,” “side,” “forward,” and “rearward” and the like may be used in this specification to describe various example features and elements, these terms are used herein as a matter of convenience, e.g., based on the example orientations shown in the figures and/or the orientations in typical use. Nothing in this specification should be construed as requiring a specific three dimensional or spatial orientation of structures in order to fall within the scope of the claims.

FIGS. 1-4 depict an exemplary insulating device 10 that can be configured to keep desired contents stored cool or warm for an extended period of time. The insulating device can generally include an outer shell 501, a closure 301, an insulating layer 502, and an inner liner 500. As shown in

FIG. 3C, the inner liner 500 forms a chamber or receptacle 504 for receiving the desired contents therein. As shown in FIG. 1A, various handles, straps, and webs (e.g. 210, 212, 218, 224) can also be included on the insulating device 10 for carrying, holding, or securing the insulating device 10.

The insulating device 10 can be configured to keep desired contents stored in the receptacle 504 cool or warm for an extended period of time. In one example, the insulating device 10 can also be designed to maintain water inside the inner chamber or receptacle 504, and the insulating device 10 can be configured to be water “resistant” from the outside in. In other words, the insulating device 10 can be formed “water tight” inside the inner liner 500, and water cannot leak into the inner liner 500 from the outside or out from the inside of the inner liner 500 when the closure 301 is in the closed position.

FIG. 4 depicts a bottom view of the insulating device 10. As shown in FIG. 4, the insulating device 10 may include a base 215 and a base support ridge 400. The base support ridge 400 can provide structural integrity and support to the insulating device 10 when the insulating device 10 is placed onto a surface.

In one example, as shown in FIGS. 3A and 4, the top of the outer shell 501 has a first perimeter circumference (T_{cir}) and the bottom of the outer shell 501 has a second perimeter circumference or a base perimeter 401 (B_{cir}). The circumference of the top of the outer shell 501 can be equal to the circumference on the bottom when folded into a cylinder, and B_{cir} can be equal to T_{cir} . In one example, the first circumference and the second circumference can both have an oval shape to form an elongated or elliptical cylinder. In one example, the top outer layer 501a can have a length of 23.5 inches and a width of 5.5 inches. Therefore, the length to width ratio of the top outer layer 501a can be approximately 4.3. Additionally, the base 215 can have a length of 20.0 inches and a width of 12.25 inches. Therefore, the length to width ratio of the base 215 is approximately 1.6. In this example, the length to width ratio of the upper wall can be greater than the length to width ratio of the base.

In one example, as shown in FIG. 5A, the inner layer or inner liner 500 can be formed of a top inner liner portion or first inner liner portion 500a, an inner layer mid portion or second portion 500b, and an inner layer bottom portion 500c. The top inner liner portion 500a, the inner layer mid portion 500b, and the inner layer bottom portion 500c are secured together, by for example welding, to form the chamber 504. The chamber 504 can be a “dry bag,” or vessel for storing contents. In one example, after the top inner liner portion 500a, the inner layer mid portion 500b, and the inner layer bottom portion 500c are secured or joined together, a tape, such as a TPU tape can be placed over the seams joining the sections of the chamber 504. The inner liner 500 can, thus, either maintain liquid in the chamber 504 of the insulating device 10 or prevent liquid contents from entering into the chamber 504 of the insulating device 10. In one example, as will be described in further detail below, the inner liner 500 can be suspended in the insulating device 10 by only the closure 301.

The insulating layer 502 can be located between the inner liner 500 and the outer shell 501, and can be formed as an insulator to assist in maintaining the internal temperature of the receptacle 504. In one example, the insulating layer 502 can be a free floating layer that is not attached directly to the outer shell 501 or the inner liner 500. The insulating layer 502 can be formed of a first portion 502a and a second portion or base portion 502b. The first portion 502a and the

5

second portion **502b** can be formed of an insulating foam material as will be described in further detail below.

The first portion **502a** can have a rectangular shape that maintains its form when folded into a cylinder and placed in between the inner liner **500** and the outer shell **501** and when encased from above by the outer shell **501**. The insulating layer **502** maintains its shape which results in the basic oval-cylindrical shape of the insulating device **10**. Therefore, similar to the outer shell **501**, the top of the insulating layer **502** has a first perimeter circumference, and the bottom of the insulating layer **502** has a second perimeter circumference. The first perimeter circumference of the insulating layer **502** can be equal to the second perimeter circumference of the insulating layer **502**.

The base portion **502b** can be included to provide additional insulation along the insulating device **10** at base **215**. The base portion **502b** can be formed as an oval shape to close off a lower opening **506** formed by the cylindrical shape of the insulating layer **502**.

Additionally, the bottom portion of the insulating device **10** can include an additional base support layer **505**, which adds to the insulation and the structural integrity of the insulating device **10**. The base support layer **505** may also provide additional protection around the bottom of the insulating device **10**. In one example, the base support layer **505** can be formed from EVA foam. The base support layer **505** may include a certain design such as a logo or name that can be molded or embossed directly into the material. The base support ridge **400**, which provides structural integrity and support to the insulating device **10** can also be molded or embossed directly into the base support layer **505**. In one example, the base support layer **505** and the base portion **502b** can be detached for ease of assembly.

The outer shell **501** can be formed of a top outer layer portion or first shell portion **501a**, an outer layer or second outer shell portion **501b**, and a bottom or third shell portion **501c**. The outer shell **501** provides a covering for the insulating device **10**. In one example, the insulating layer **502** can be suspended freely within the outer shell **501**. However, it is contemplated that any of the layers could be secured or formed as a one-piece integral structure. The outer shell **501** can be configured to support one or more optional handles or straps (e.g. **210**, **212**, **218**). In this regard, the outer shell **501** can also include multiple reinforcement areas or patches **220** that are configured to assist in structurally supporting the optional handles or straps (e.g. **210**, **212**, **218**). The handles or straps (e.g. **210**, **212**, **218**) and other attachments can be stitched using threads **222**, however these threads **222** do not, in one example, extend through the outer shell **501** into the insulating layer **502**. Rather, the threads are sewn to the patches **220**, and the patches **220** can be RF welded to the outer shell **501** or by any other method disclosed herein.

As shown in FIG. 5A, the first outer shell portion **501a** may be attached to the second shell portion **501b** by stitching **510**. However, the first outer shell portion **501a** can be attached to the second shell portion **501b** using any known method, e.g., polymer welding, stitching, or other adhesive around the entire perimeter of the second shell portion **501b**.

Additionally, in one example, the base support layer **505**, which can be formed from EVA foam, can be secured to bottom or third shell portion **501c** by lamination. The second shell portion **501b** can be secured to the third shell portion **501c** and the base support layer **505** by polymer welding (e.g. RF welding), stitching, or adhesives.

The insulating device **10** can include two carry handles **210** that are connected to the frontside **216** of the insulating

6

device **10** and the backside **217** of the insulating device **10**. In one particular example, a shoulder strap **218** can be attached via plastic or metal clip to the ring **214** attached to side handles **212** to facilitate carrying insulating device **10** over the shoulder. The insulating device **10** may also include side handles **212** on each end of the cooler. The side handles **212** provide the user with another option for grasping and carrying the insulating device.

Carry handles **210** may also form a slot for receiving rings **214** near the bottom of the attachment point of the carry handles to the insulating device **10**. The rings **214** can be secured to the carry handles **210** and the attachment points **213** by stitching, adhesive, or polymer welding and can be used to help secure or tie down the insulating device **10** to another structure such as a vehicle, vessel, camping equipment, and the like or various objects such as keys, water bottle bottles, additional straps, bottle openers, tools, other personal items, and the like.

Additionally, as shown in FIG. 2, webbing formed as loops **224** can be sewn onto the straps forming the handles **210** on the back of the insulating device **10**. The loops **224** can be used to attach items (e.g., carabineers, dry bags) to the insulating device **10**. The side handles **212** can also provide the user with another option for securing the insulating device **10** to a structure.

In one example, the carry handles **210**, side handles **212**, shoulder strap **218** and attachment points **213** can be constructed of nylon webbing. Other materials may include polypropylene, neoprene, polyester, Dyneema, Kevlar, cotton fabric, leather, plastics, rubber, or rope. The carry handles **210** and side handles **212** can be attached to the outer shell by stitching, adhesive, or polymer welding.

The shoulder strap **218** can be attached to the insulating device **10** at attachment points **213**. The attachment points **213** can be straps that also form a slot for receiving rings **214**. The rings **214** can provide for the attachment of the shoulder strap **218**.

In one example, the rings **214** can be Acetal D-rings. Rings **214** can be plastic, metal, ceramic, glass, alloy, polypropylene, neoprene, polyester, Dyneema, and Kevlar, cotton fabric, leather, plastics, rubber, or rope. Rings **214** can include other shapes, sizes, and configurations other than a "D" shape. Examples include round, square, rectangular, triangular, or rings with multiple attachment points. Additionally, pockets or other storage spaces can be attached to the outside of the insulating device **10** in addition to the carry handles **210** and side handles **212**.

In one example, the closure **301** can be substantially waterproof or a barrier to prevent liquid contents from either entering or exiting the insulating device. Additionally, the closure **301** can be impervious to liquid such that insulating device **10** liquid penetration is prevented at any orientation of the insulating device **10**. Also maintaining the closure **301** in flat plane can assist in providing a water tight seal.

FIGS. 3A-3C depicts top views of the insulating device **10**, and depicts the top outer layer or the first outer shell portion **501a** and the closure **301**. The top outer layer **501a** depicted in FIG. 3A can be secured to the closure **301**. In one example, the closure **301** can be a waterproof zipper assembly and can be watertight up to 7 psi above atmospheric pressure during testing with compressed air. However, in other examples, the water tightness of the closure **301** can be from 5 psi to 9 psi above atmospheric pressure and in other examples, the water tightness of the closure **301** can be from 2 psi to 14 psi above atmospheric pressure. The waterproof zipper assembly can include a slider body **303** and pull-tab **302**. FIG. 3B shows a magnified view of the closure **301** that

includes bottom stop **304** and teeth or a chain **305**. In one particular example, the waterproof zipper assembly can be constructed with plastic or other non-metallic teeth **305** to prevent injury when retrieving food or beverages from the inner chamber **504**.

As shown in FIG. **3C**, the closure **301** is open or unzipped and an aperture **512** formed in the outer shell **501** and the inner liner **500** is open and reveals the inner liner **500** and the inner chamber **504**. It is contemplated that the closure or seal **301** can include various sealing devices in addition to the depicted waterproof zipper assembly in FIGS. **3A-3C**. For example, Velcro, snaps, buckles, zippers, excess material that is folded multiple times to form a seal such as a roll-down seal, seals, metal or plastic clamps and combinations thereof could be used to seal the inner liner **500** and the outer shell **501**.

FIGS. **8A** and **8B** depict another exemplary insulating device **1010**, which has similar features and functions as the example discussed above in relation to FIGS. **1A-5B** in which like reference numerals refer to the same or similar elements. However, in this example, a loop patch **1015** can be provided on the front of the bag. The loop patch **1015** can be configured to receive many types of items or a corresponding group of hooks, which can be placed onto the surface anywhere on various items, such as fishing lures, keys, bottle openers, card holders, tools, other personal items, and the like. The loop patch **1015** can include a logo, company name, personalization, or other customization. The loop patch **1015** can be formed of by needle loops and can have a high cycle life of over 10,000 closures. In addition, the loop patch can be washable and UV resistant to prevent discoloration. The loop patch can be selected based on a desired shear and peel strength depending on the types of materials that are to be secured to the insulating device **1010**.

In the example shown in FIGS. **8A** and **8B**, additionally, a strip **1013** of material can be provided along the bottom of the bag, which can provide additional strength and reinforcement to the outer shell **1501**, and may enhance the aesthetics of the insulating device **1010**.

Example methods of forming the insulating device **10** will now be described. A general overview of an exemplary assembly process of the insulating device **10** is depicted schematically in FIG. **6**. The various steps, however, need not necessarily be performed in the order described. As shown in step **602** first the portions used to form the inner liner **500**, the outer shell **501**, and the insulating layer **502** can be formed or cut to size. In step **604**, a top cap assembly **300** can be assembled to the closure **301**. In step **606**, the inner liner **500** can be formed, and in step **608**, the top cap assembly **300** can be welded to the inner liner **500**. In step **610**, the outer shell **501** can be formed. In step **612**, the insulation layer **502** can be assembled, and in step **616**, the insulation layer **502** can be placed into the inner liner. Finally, in step **618**, the top cap assembly **300** can be secured to the outer shell **501**.

Referring to step **602**, as shown in FIGS. **7A** and **7B**, inner liner top portions or first inner liner portions **500a** and top outer layer **501a** that form the top cap assembly **300** can be formed or cut to size. FIG. **7C** shows a second portion or base portion **502b** of the insulating layer **502** being cut or formed to size from stock foam. In this example, the base portion **502b** is cut from the stock foam **530**, by cutting tool **700**. In one example, the cutting tool **700** can be formed in the shape of the base portion **502b**.

Referring now to step **604** and FIG. **7D**, the top outer layer **501a** and the top inner liner portion **500a** can be secured to the closure **301** to form the top cap assembly **300**, and the

top outer layer **501a** and the top inner liner portion **500a** can be secured to the closure **301** in a flat, horizontal plane. Referring to FIGS. **5A-5B** the top outer layer **501a** can be attached by polymer welding or adhesive to closure **301**. In particular as shown schematically in FIG. **5B**, the closure **301** can be provided with a first flange **301a** and a second flange **301b**, which can form waterproof zipper tape **306**. The top outer layer **501a** can be attached directly to the top surfaces of the first flange **301a** and the second flange **301b** of the closure **301**. In one example, the first flange **301a** and the second flange **301b**, can be RF welded to the underside of the top outer layer **501a**. In another example, as shown in FIG. **7E**, the top inner liner portion **500a** can be provided with tabs **515**. Tabs **515** can assist in the assembly process to keep the outer strips of the top inner liner portion **500a** in place during assembly and can be removed after the top cap assembly **300** is formed.

In one example, the top inner liner portion **500a** can be attached to the structure of the insulating device **10** as shown schematically in FIG. **5B**. In particular, the top inner liner portion **500a** can be attached to the bottom of the closure **301**. For example, as shown in FIG. **5B**, and a first end **540a** and a second end **540b** of the top inner liner portion **500a** can be attached to undersides of the first flange **301a** and the second flange **301b**. The top inner liner portion **500a** and the top outer layer **501a** can be attached to the closure **301** by polymer welding or adhesive. Polymer welding includes both external and internal methods. External or thermal methods can include hot gas welding, hot wedge welding, hot plate welding, infrared welding and laser welding. Internal methods may include mechanical and electromagnetic welds. Mechanical methods may include spine welding, stir welding, vibration welding, and ultrasonic welding. Electromagnetical methods may include resistance, implant, electrofusion welding, induction welding, dielectric welding, RF (Radio Frequency) welding, and microwave welding. The welding can be conducted in a flat or horizontal plane to maximize the effectiveness of the polymer welding to the construction materials. As a result, a rugged watertight seam can be created that prevents water or fluids from escaping from or into the inner chamber **504**.

In a particular example, the polymer welding technique to connect the top inner liner portion **500a** to the bottom of the closure **301** can include RF welding. The RF welding technique provides a waterproof seam that prevents water or any other fluid from penetrating the seam at pressure up to 7 psi above atmospheric pressure. The insulating device **10**, therefore, can be inverted or submerged in water and leakage is prevented both into and out of the internal chamber **504** formed by inner liner **500**. In one example, the insulating device **10** can be submerged under water to a depth of about 16 feet before water leakage occurs. However, it is contemplated that this depth could range from about 11 feet to 21 feet or 5 feet to 32 feet before any leakage occurs.

Next referring to step **606** and FIG. **7F**, the inner layer mid-portion **500b** can be formed by RF welding. As shown in FIG. **7F**, the inner layer mid-portion **500b** can be formed of a rectangular sheet of material. The inner layer mid-portion **500b** can also be secured to the inner layer bottom portion **500c** in a subsequent step not shown.

Referring to step **608** and FIGS. **7G** and **7H**, the inner layer mid portion **500b** and the inner layer bottom portion **500c** can be secured to the top cap assembly **300** using an RF welding operation.

Referring to step **610**, the second shell portion **501b** and the third shell portion **501c**, which supports the base support layer **505**, can be RF welded to construct the outer shell **501**

for the insulating device **10**. In one example, as shown schematically in FIG. **5A**, the top outer layer **501a** can be sewed to the perimeter of the second shell portion **501b** to form the outer shell **501** of the insulating device. A fabric binding can be used to cover the stitched seam edges of the second shell portion **501b** and the top outer layer **501a**. This assists in closing or joining the outer shell **501** around the insulating layer **502**.

Referring to step **612** and FIG. **71**, the insulating layer **502** can be constructed. In one example the first portion **502a** of the insulating layer **502** can be formed into a rectangular shape and can be secured at the smaller sides of the rectangular shape using double sided tape to form the cylindrical shape. The second portion or base portion **502b** can be formed into an oval shape that can have a smaller circumference than the circumference of the cylindrical shape of the first portion **502a**. The second portion **502b** can be secured to the first portion **502a** also using a double-sided tape to form the insulating layer **502**. In one example, double sided tape can be placed either around the inner perimeter of the first portion **502a** cylinder or around the outer perimeter of the base portion **502b**, and the base portion **502b** can be adhered to the first portion **502a**. Other methods of securing the base portion **502b** to the first portion **502a** to form the insulating layer **502** are contemplated, such adhesives or polymer welding.

Referring to step **614**, the assembled insulating layer **502** can be placed into the outer shell **501**. In step **616**, the formed inner liner **500** and top cap assembly **300** can be placed into the insulating layer **502**.

Finally in step **618** the top cap assembly **300** can be sewed to the outer shell **501** to form seams **520** as depicted schematically in FIG. **5A**. In this way, neither the inner liner **500** nor the outer shell **501** need to be bound to the insulating layer **502**. Also the inner liner **500** is only connected to the closure **301** and the closure **301** holds the inner liner and the outer shell **501** together, which results in a simpler manufacturing process. After sewing the top cap assembly **300** to the outer shell **501**, a fabric binding is added to cover the raw edges adjacent the seams **520**. Thus, the top seams **520** can be the only primary seams on the insulating device **10** that are created by stitching.

In one particular example, the inner liner **500** and the outer shell **501** can be constructed from double laminated TPU nylon fabric. Nylon fabric can be used as a base material for the inner liner **500** and the outer shell **501** and can be coated with a TPU laminate on each side of the fabric. The TPU nylon fabric used in one particular example is 0.6 millimeters thick, is waterproof, and has an antimicrobial additive that meets all Food and Drug Administration requirements. However, it is contemplated that the fabrics used to construct the insulating device incorporate antimicrobial materials to create a mildew-free environment that is food contact surface safe. In one specific example, the nylon can be 840d nylon with TPU. Alternative materials used to manufacture the inner shell or chamber **504** and outer shell **501** include PVC, TPU coated nylon, coated fabrics, and other weldable and waterproof fabrics.

A closed cell foam can be used to form the insulating layer **502** that is situated in between the inner liner **500** and the outer shell **501**. In one example, the insulating layer **502** is 1.0 inches thick. In one example, the insulating layer **502** can be formed of NBR/PVC blend or any other suitable blend. The thermal conductivity of an example insulating layer **502** can be in the range of 0.16-0.32 BTU·in/(hr·sqft·° F.), and the density of the insulating layer **502** can be in the range of 0.9 to 5 lbs/ft³. In one example, the thermal

conductivity of the insulating layer **502** can be in the range of 0.25 BTU·in/(hr·sqft·° F.), and the density of the insulating layer **502** can be 3.5 lbs/ft³.

The foam base can be manufactured from an NBR/PVC blend or any other suitable blend. In addition to the base portion **502b** of the insulating layer **502**, the insulating device **10** may also include an outer base support layer **505** constructed of foam, plastic, metal or other material. In one example, the base portion **502b** can be detached from the base support layer. In one example, the base portion **502b** is 1.5 inches thick. Additionally as shown in FIG. **5A**, the EVA foam base support layer **505** can be 0.2 inches thick. Although the base support layer **505** is laminated to the base outer layer or third shell portion **501c**, in an alternative example, the base support layer **505** can be attached to the bottom of the base portion **502b** by co-molding, polymer welding, adhesive, or any known methods.

A heat gain test was conducted on the exemplary insulating device **10**. The purpose of a heat gain test is to determine how long the insulating device can keep temperature below 50° F. at an ambient of 106° F.±4 with the amount of ice based on its internal capacity.

The procedure is as follows:

1. Turn on the oven and set to 106° F.±4. Allow the oven to stabilize for at least one hour.
 2. Turn on the chart recorder. The recorder shall have three J-thermocouples connected to it to chart the following temperatures: (1) Test unit, (2) Oven, and (3) Room ambient.
 3. Stabilize the test unit by filling it to half its capacity with ice water, and allowing it to sit for 5 minutes at room temperature (72° F.±2).
 4. After 5 minutes, pour out the contents, and immediately connect the J-thermocouple end to the inside bottom center of the unit. The thermocouple wire end must be flush to the inside bottom surface and secured with an adhesive masking tape.
 5. Pour the correct amount of ice ensuring the thermocouple wire is not moved. Amount of ice is based on 4 lbs. per cubic feet of the internal capacity of the unit.
 6. Close the lid and position the test unit inside the oven.
 7. Close the oven making sure the thermocouple wires are functioning.
 8. Mark the start of the chart recorder.
- Apparatus: 1. Oven. 2. Ice. 3. Chart Recorder. 4. J-Thermocouples (3). Results: 1. Cold Retention Time: Elapsed time from <32° F. to 50° F. in decimal hours. 2. Heat Gain Rate (° F./Hr): (50° F.-32° F.)÷Elapsed Time=18° F.÷Elapsed Time

In one test of the example insulating device, the heat gain rate equaled 1.4 degF/hr assuming 26.5 quarts capacity and used 3.542 lbs of ice for the test.

The ability of the insulating device **10** to withstand interior leaks can also be tested to see how well the insulating device maintains the contents stored in the storage compartment or receptacle **504**. In one example test, the insulating device **10** can be filled with a liquid, such as water, and then can be inverted for a predetermined time period to test for any moisture leaks. In this example, the insulating device **10** is filled with a liquid until approximately half of a volume of the receptacle **504** is filled, e.g. 3 gallons of water, and the closure **301** is then closed fully to ensure that the slider body **303** is completely sealed into the horseshoe-shaped portion **308**. The entire insulating device **10** is then inverted and held inverted for a time period of 30 minutes. The insulating device **10** is then reviewed for any leaks.

11

The insulating device **10** can be configured to withstand being held inverted for 30 minutes without any water escaping or leaving the receptacle **504**. In alternative examples, the insulating device can be configured to withstand being held inverted for 15 minutes to 120 minutes without any water escaping or leaving the receptacle **504**. To perform this test, it may be helpful to lubricate the closure to ensure that the closure is adequately sealed. For example, as shown in FIG. 9, a horseshoe-shaped portion **308** of the closure **301** is provided with lubricant **309**.

The strength and durability of the fabric forming the outer shell **501**, inner liner **500** and the insulating layer **502** of the insulating device **10** may also be tested. In one example, the test can be devised as a puncture test. In particular, this test can be designed as an ASTM D751-06 Sec. 22-25 screw-driver puncture test. In one example, the insulating device **10** can withstand 35 lbs to 100 lbs of puncture force.

The handle strength and durability of the insulating device **10** can also be tested. One such example test is depicted in FIG. 10. As depicted in FIG. 10, the closure **310** can be fully closed, one of the carry handles **210** can be hooked to an overhead crane **600**, and the opposite carry handle **210** is hooked to a platform **650**, which can hold weight. In one example, the platform **650** can be configured to hold 200 lbs. of weight. During the test, the crane **600** is slowly raised, which suspends the insulating device **10** in a position where the bottom plane of the insulating device **10** is perpendicular with the floor. In one example, the insulating device **10** can be configured to hold 200 lbs. of weight for a minimum of 3 minutes without showing any signs of failure. In alternative examples, the insulating device can be configured to hold 100 lbs. to 300 lbs. of weight for 1 to 10 minutes without showing signs of failure.

FIGS. 11-15 show another example insulating device **2010**. The example insulating device **2010** can be of a similar construction to the above examples, where like reference numerals represent like features having similar functionality. However, the example insulating device **2010** can also include a fold-down flap or portion **2307** to assist in insulating the closure **2311** of the insulating device **2010**. Specifically, the closure **2311**, which can be a zipper in accordance with the other examples discussed herein, can be included on a fold-down flap or portion **2307** and can be front facing in that it is located on a front surface or wall of the insulating device **2010**. The front facing closure **2311**, can allow for additional user access to the insulating device **2010**, and the fold-down flap or portion **2307** can help to provide additional insulation at the closure **2311**. In this example, when the fold-down flap **2307** is in the extended position and the closure **2311** is open or unsealed, the contents in the insulating device **2010** maintain the closure **2311** in the open position for better access of the contents of the insulating device **2010**. This may assist the user to be able to more easily access the contents of the insulating device **2010**. Also as shown in FIG. 11, when the fold-down flap **2307** is in the extended position, the insulating device **2010** can approximate a trapezoidal shape for providing an elongated closure at the top of the insulating device **2010**.

As shown in the side and cross-sectional views, i.e., FIGS. 12 and 14A, the insulating device **2010** can approximate a pentagon, when the fold-down flap **2307** of the insulating device **2010** is in an extended position. This general shape may provide for an insulating device **2010** that may be easily shipped in that several insulating devices can be fit into a shipping container. Nevertheless, other shapes and configurations are contemplated e.g., square, rectangular, triangular,

12

conical, curved, and frusto-shapes which may provide an extended closure at the top of the insulating device **2010** and that can be easily packaged.

Like in the above examples, the insulating device **2010** may include an outer shell **2501**, an inner liner **2500** forming a storage compartment, a receptacle, or inner chamber **2504** and an insulating layer **2502** positioned in between the outer shell **2501** and the inner liner **2500**. The insulating layer **2502** provides insulation for the storage compartment **2504**. The closure **2311** can be configured to substantially seal an opening **2512**, which is located on an angled front facing surface and extends through the outer shell **2501** and the inner liner **2500** to provide access to the storage compartment **2504**. Also, the closure **2311** can include similar features and functionality in accordance with the examples discussed above. In one example, the closure **2311** can be a zipper and can be substantially waterproof so as to resist liquid from exiting the opening when the insulating device **2010** is in any orientation. Also, similar to the above examples, the insulating device **2010** can be provided with one or more of carry handles **2210**, shoulder straps **2218**, webbing loops **2224** formed with threads **2222** by stitching for example, rings **2214**, and attachment points **2213** which can have similar features and functionality as in the examples above.

As shown in FIGS. 11 and 12 and as noted above, the fold-down flap **2307** may include the front facing closure **2311** and can be folded over and secured to a sidewall of the insulating device **2010** to further insulate the front facing closure **2311**. The fold-down flap **2307** of the fastening mechanism **2301** can include first and second end hooks or clips **2313a**, **2313b**. In one example, each of the end clips **2313a**, **2313b** can include a slot **2317a**, **2317b** for being received in corresponding loops **2315a**, **2315b** located on the sides or the sidewalls of the insulating device **2010**. To close the insulating device **2010**, the fold-down flap **2307** along with the front facing closure **2311** are folded over onto a front face or wall of the insulating device **2010**. The fold-down flap **2307** folds over with and conceals or covers the front facing closure **2311**. The fold-down flap **2307** is held into place by the first and second end clips **2313a**, **2313b** and maintains the fastening mechanism **2301** in the closed position. Additionally, when the fold-down portion **2307** is secured to the sidewalls of the insulating device **2010**, the fold-down portion **2307** extends at least partly in a substantially horizontal direction, which orients a carrying handle **2318** in position for a user to grasp for holding and carrying the insulating device **2010**. As in the other handles and straps, the carry handle **2318** can be secured to the outer shell with a reinforcement patch (not shown). The carry handle **2318** can be provided on the rear surface of the insulating device **2010** to oppose the closure **2311** on the front facing surface, which can be used by the user to grasp during opening and closing the insulating device **2010** to make it easier for the user to open and close the closure **2311**. The carry handle **2318** may also be used for hanging the insulating device **2010**, or for carrying the insulating device **2010**; however, other uses are also contemplated.

FIG. 14A shows a cross-sectional side view of the insulating device **2010**. The insulating device **2010** includes an inner liner **2500**, an insulating layer **2502**, and an outer shell **2501**. As shown in FIG. 14A, like in the above examples, the insulating layer **2502** can be located between the inner liner **2500** and the outer shell **2501**, and can be formed as a foam insulator to assist in maintaining the internal temperature of the receptacle **2504** for storing contents desired to be kept cool or warm. Also the insulating layer **2502** can be located

in between the inner liner **2500** and the outer shell **2501**, and can be unattached to either the inner liner **2500** or the outer shell **2501** such that it floats between the inner liner **2500** and the outer shell **2501**. In one example, the inner liner **2500** and the outer shell **2501** can be connected at the top portion of the insulating device **2010** such that the insulating layer **2502** can float freely within a pocket formed by the inner liner **2500** and the outer shell **2501**.

In this example, the inner layer or inner liner **2500** can be formed of a first inner liner sidewall portion **2500a** and a bottom inner liner portion **2500b**. The first inner liner sidewall portion **2500a** and the bottom inner liner portion **2500b** can be secured together, by for example welding, to form the chamber **2504**. Like in the above example, the chamber **2504** can be a “dry bag,” or vessel for storing contents. In one example, a tape, such as a TPU tape, can be placed over the seams joining the sections of the chamber **2504**, after the first inner liner sidewall portion **2500a** and the bottom inner liner portion **2500b** are secured or joined together. The tape seals the seams formed between the first inner liner sidewall portion **2500a** and the bottom inner liner portion **2500b** to provide an additional barrier to liquid to prevent liquid from either entering or exiting the chamber **2504**. The inner liner **2500** can, thus, either maintain liquid in the chamber **2504** of the insulating device **2010** or prevent liquid contents from entering into the chamber **2504** of the insulating device **2010**. It is also contemplated, however, that the inner liner **2504** can be formed as an integral one-piece structure that may be secured within the outer shell.

As shown in both FIGS. **14A** and **15**, the insulating layer **2502** can be formed of a first portion or an upper portion **2502a**, a second portion or base portion **2502b**, and a base support layer **2505**. In addition, the first portion **2502a** can include a top flap or smaller rectangular shape **2502a1**. When the fold-down flap **2307** is folded onto the top portion of the insulating device **2010**, the top flap **2502a1** of the insulating layer together with the remainder of the first portion **2502a** and the base portion **2502b** surrounds substantially all of the inner chamber **2504** with insulation to provide a maximum amount of insulation to the inner chamber **2504** of the insulating device **2010**.

When the upper portion **2502a** is rolled flat, the upper portion **2502a** of the insulating layer **2502** generally resembles a “T” shape such that the insulating layer defines a first height H_1 and a second height H_2 , where the first height H_1 is greater than the second height H_2 . In this example, a majority of the insulating layer can extend to the second height H_2 , which is less than the first height H_1 . Also, the first portion **2502a** can be formed of two inter-connected rectangular shapes, where the bottom of the first portion **2502a** forms a first larger rectangular shape **2502a2** and an upper section of the first portion **2502a** forms the top flap **2502a1** of the smaller rectangular shape. It is also contemplated that the first larger rectangular shape **2502a2** can be formed as a separate piece from the smaller rectangular shape **2502a1**. The first rectangular shape **2502a2** can have a first rectangular width and the second rectangular shape **2502a1** can have a second rectangle perimeter and first rectangular shape **2502a2** width approximates the second rectangular shape **2502a1** perimeter. In one example, the smaller rectangular shape **2502a1** forms a top flap of the insulation layer of the upper portion **2502a**, which extends into the fold-down portion **2307**.

The first portion **2502a** and the second portion **2502b** can be formed of an insulating foam material as discussed herein. In one example, the second portion **2502b** can be

formed of a thicker foam material than the first portion **2502a**. For example, the thickness of the second portion **2502b** can be formed between 20 mm and 50 mm thick, and, in one particular example, can be formed of a 38 mm thick foam, and the first portion **2502a** can be formed between 15 mm and 30 mm, and, in one particular example, can be formed of a 25 mm thick foam. In one example, the foam can be a NBR/PVC blended foam, a PVC free NBR foam, or other eco-friendly type foam.

Also as shown in FIG. **15**, a base support layer **2505** adds to the insulation and the structural integrity of the insulating device **2010** at base **2215**. The base support layer **2505** may also provide additional protection around the bottom of the insulating device **2010**. In one example, the base support layer **2505** can be formed from EVA foam. The base support layer **2505** may include a certain design such as a logo or name that can be molded or embossed directly into the material. A base support ridge **2400**, which provides structural integrity and support to the insulating device **2010** can also be molded or embossed directly into the base support layer **2505**. In one example, the base support layer **2505** and the base portion **2502b** can be detached or unsecured for ease of assembly in reducing the number of assembly steps. The base portion **2502b** can be formed as an oval shape to close off a lower opening **2506** formed by the open shape of the upper portion **2502a**.

The bottom of the first portion **2502a** maintains its form when folded into an oval-cylindrical shape and placed in between the inner liner **2500** and the outer shell **2501**. The insulating layer **2502** maintains its shape which results in the basic oval-cylindrical shape of the insulating device **2010**.

The outer shell **2501** can be formed of an upper sidewall portion **2501a**, a lower sidewall portion **2501b**, and a base portion **2501c**. Each of the upper sidewall portion **2501a**, the lower sidewall portion **2501b**, and the base portion **2501c** can be secured by stitching. Other securing methods are also contemplated, such as, using welds or adhesives.

Additionally, the fold-down portion **2307** can be at least partly free of foam to make it easier to close the fastening mechanism **2301**. In particular, the fold-down portion **2307** can include a first section **2307a** and a second section **2307b**. The first section **2307a** can be free of the insulation layer **2502** and the second section can include the insulation layer **2502**.

Referring to FIG. **14B**, like in the above examples, the closure **2311** can be mounted on a backing or fabric. In the case of a zipper this can be referred to as zipper tape **2306**. Also, like in the above examples, the zipper tape **2306** can be attached between the inner liner **2500** and the outer shell **2501** and, in particular, the zipper tape **2306** can be secured to the upper sidewall portion **2501a** of the outer shell and the first inner liner sidewall portion **2500a**. As shown in FIG. **14B**, the zipper tape **2306**, the upper sidewall portion **2501a** of the outer shell, and the first inner liner sidewall portion **2500a** can form a stacked arrangement of a sandwich structure where the zipper tape **2306** is located between the upper sidewall portion **2501a** of the outer shell and the first inner liner sidewall portion **2500a**.

The insulating device **2010** can be formed using similar techniques in relation to the examples as discussed above. For example, the upper sidewall portion **2501a** of the outer shell **2501** can be formed. Also the base **2215** can be formed separately with the base portion **2502b** of the insulation layer **2502**, the base support layer **2505**, the lower sidewall portion **2501b**, and a base portion **2501c** of the outer shell **2501** according to the techniques discussed herein. The base **2215** can be secured to the bottom of the upper sidewall

15

portion **2501a** of the outer shell **2501** using the techniques discussed herein. The upper portion **2502a** of the insulation layer **2502** can be placed within the upper sidewall portion **2501a** of the outer shell **2501**. The first inner liner sidewall portion **2500a** and the bottom inner liner portion **2500b** can then be secured to form the inner liner **2500** and chamber **2504**. Tape, such as a TPU tape, can be placed over the seams joining the sections of the inner liner **2500** and chamber **2504**. The inner liner **2500** can then be placed within the insulation layer **2502**. The closure **2311** can then be attached between the inner liner sidewall portion **2500a** and the upper sidewall portion **2501a**. At this point in the process the insulating device **2010** assembly will have a cylindrical shape with an open top. To close the open top, the upper ends of the inner liner sidewall portion **2500a** and the upper sidewall portion **2501a** can then be secured together by welding or by using any of the techniques discussed herein to form the insulating device **2010**. A binding **2518** can be applied to the top portion of the insulating device **2010** to cover and conceal the seam between the outer shell **2501** and the inner liner **2500**. The loop patch (not shown), carry handles **2210**, shoulder strap **2218**, webbing loops **2224**, and rings **2214** can be added to the outer shell **2501** by the various techniques discussed herein, after the formation of the outer shell or once the insulating device **2010** is formed. It is contemplated that the inner liner and the outer liner can be formed by welding, gluing, or stitching and combinations thereof.

In another example, a magnetic connection can be implemented for securing the fold-down portion **2307** to the body of the insulating device **2010**. As shown in FIGS. **16A** and **16B**, the insulating device **2010** can be provided with a magnetic clip **3313**, which can be received by a corresponding magnet (not shown) on the sidewall of the insulating device **2010**. However, it is also contemplated that the clip and clip receiving portion on the insulating device **2010** could be one or more of permanent magnets, metal strips, or ferromagnetic materials. In addition, other methods of securing the fold-down flap **2307** over the front facing closure **2311** are also contemplated. For example, one or more of hook and loop, buckle, snap, zipper, detent, spring loaded detent, button, cams, or threads could be used to secure the fold-down flap **2307** to the sidewall of the insulating device **2010**.

FIGS. **17-22** show another exemplary insulating device **4010**. The example insulating device **4010** can be of a similar construction to the above examples and, in particular, the example discussed above in relation to FIGS. **11-16B**, where like reference numerals represent like features having the same or similar functionality. In this example, the insulating device **4010** does not include a fold-down flap and can include a different overall shape than the example insulating device **2010**. Additionally, the insulating layer **4502** can have a different configuration along with other variations that will be discussed below. Like in the above example, the closure **4311** can be placed on a front face or wall of the insulating device **4010**.

As shown in FIGS. **18** and **19**, when viewed from the front and rear, the insulating device **4010** can generally form a trapezoidal shape, where the insulating device diverges or tapers upward toward the top of the insulating device **4010**. The trapezoidal shape may provide certain insulation, user accessibility, and packaging benefits. For example, the trapezoidal shape can provide an extended period of ice coverage because of the additional foam that can be placed between the outer shell **4501** and the inner liner **4500** due to the trapezoidal shape.

16

Additionally, the overall shape of the insulating device **4010** can help to maintain the insulating device **4010** in the opened position when the closure **4311** is in the opened position and permits the user to be able to easily access the contents of the insulating device **4010**. The trapezoidal shape as discussed herein also allows the closure **4311** to be formed longer relative to the insulating device **4010**. Other shapes that allow for an extended opening at the upper portion of the insulating device **4010** are also contemplated. For example, the upper portion of the insulating device **4010** could be formed with an extended curvature either upward or downward to allow for a larger closure extending across the upper portion of the insulating device **4010**. Also as shown in FIG. **20**, when viewed from the side, the insulating device **4010** can be formed generally conical, tapered or funnel-shaped such that the sides converge to the top of the insulating device **4010**. Also the sides can be formed substantially parabolic in shape in certain examples. Therefore, the insulating device **4010** converges to an apex along the top of the insulating device **4010** as opposed to an oval shape with the same perimeter as the bottom of the insulating device **4010**.

In certain examples, a trapezoidal shape may also provide for an insulating device **4010** that may be easily shipped in that several insulating devices **4010** can be fit into a shipping container. For example, multiple insulating devices **4010** could be arranged in a shipping container in different orientations so as to utilize more space within a shipping container.

In alternative embodiments, when the closure **4311** is in the opened or unsealed position, the contents in the insulating device **4010** may maintain the closure **4311** in the open position for easier access to the contents of the insulating device **4010**. In this example, the weight of the contents can force a lower half of the closure **4311** away from an upper half of the closure **4311** such that the user can better see the contents of the insulating device **4010** and more easily remove the contents or add contents to the insulating device **4010**.

In this example, the outer shell construction, insulating layer, and the inner liner construction can be similar to that of the embodiment discussed above in relation to FIGS. **11-16B**, the details of which are not repeated here. The outer shell **4010** may also include a top portion **4316**, which is configured to receive the closure **4311** therein. The top portion **4316** can be formed of the same material as the remaining outer shell **4501**, which in one specific example, can be nylon and specifically an **840d** nylon with TPU.

Similar to the example discussed in relation to FIGS. **11-16B**, the insulating device **4010** can be provided with one or more of carry handles **4210**, a shoulder strap **4218**, webbing loops **4224**, which are formed by threads **4222**, rings **4214**, and attachment points **4213** which can have similar features and functionality as in the examples above.

Additionally, a rear carry handle **4318** can be provided on the rear surface of the insulating device **4010** to oppose the closure **4311**, which can be used by the user to grasp during opening and closing the insulating device **4010** to make it easier for the user to open and close the closure **4311**. The rear carry handle **4318** may also be used for hanging the insulating device **4010** for drying the inner chamber **4504**, or for carrying the insulating device **4010**. Each of the carry handles **4210**, shoulder strap **4218**, webbing loops **4224**, and attachment points **4213** can be reinforced by one or more of additional structures in the form of webbing or suitable polymeric materials. This reinforcement material may be applied to any of the examples discussed herein.

Also as shown in FIGS. 17 and 21 a binding 4518 can be included that extends over the top of the insulating device 4010 to secure the outer shell 4501 to the inner liner 4500. The binding 4518 can be folded over the top of the insulating device 4010 and then stitched over the over outer shell 4501 and the inner liner 4500 to form a cover to the joint or seam between the inner liner 4500 and the outer shell 4501. As shown in FIG. 18, the binding 4518 can be folded into thirds to form a first folded portion 4518a where the first third is attached to a first side of the insulating device 4010, the second third is extends over the top of the insulating device 4010, and the last third is attached to a second side of the insulating device 4010. The binding 4518 covers the seam between the outer shell 4501 and the inner liner 4500 along the top of the insulating device 4010. Also, as shown in FIG. 17, the binding 4518 extends from the top of the insulating device 4010 and forms a second folded portion 4518b where the binding 4518 is folded in half and a third unfolded portion 4518c, which forms and extends to attachment points 4213 that receive rings 4214. Each side of the insulating device 4010 can include a second folded portion 4518b and a third unfolded portion 4518c such that the insulating device 4010 can include two second folded portions 4518b and two third unfolded portions 4518c. The binding 4518 can unfold closer to the attachment points 4213 and may also be formed unfolded from the attachment points 4213 to the top of the insulated device 4010. In either of these configurations, a section of the binding 4518, e.g., the second folded portion 4518b, can be unattached to the insulating device 4010 and forms a strap between the folded portion 4518a and the attachment points 4213. In this example, two straps can be formed by the two second unfolded portions 4518b and can be grasped by the user for handling the insulating device, can be used for hanging the insulating device 4010 for drying, and the like. Also, the attachment points 4213 formed by the binding 4518 can be a loop or slot for receiving the rings 4214.

FIGS. 22 and 22A show the insulating layer 4502 in additional detail, which is similar to the example insulating device 4010 discussed above where like reference numerals represent like components with the same or similar functionality. The insulating layer 4502 can be formed of the materials as discussed herein and, in certain examples, can be PVC free and/or can have non-thermoset properties such that the foam is fully resilient.

Like the above examples, the upper portion 4502a of the insulating layer 4502 can be formed of a single sheet of material which is rolled into the shape defined by the opening between the inner liner 4500 and the outer shell 4501. As shown in FIG. 22, the insulating layer 4502, like in the above examples, can be formed of a first portion or an upper portion 4502a and a second portion or base portion 4502b. The rear top flap 4502a1 can be formed in smaller rectangular shape. The rear top flap 4502a1 extends higher than the front side of the first portion 4502a of the insulating layer 4502a to accommodate for the front facing closure 4311. Specifically, the rear top flap 4502a1 can extend to a first height H_3 , and the first portion 4502a can extend to a second height H_4 , and the first height H_3 can be greater than the second height H_4 . Additionally, as shown in FIG. 22, a majority of the insulating layer 4502 can extend to the second height H_4 . Alternatively, as shown in FIG. 22A, the rear half of the insulating layer 4502 can extend to the first height H_3 and the front half of the insulating layer 4502 can extend to the second height H_4 . Additionally, as shown in FIG. 22A, the insulating layer 4502 can taper from the first height H_3 to the second height H_4 . Also, this provides the

areas of the insulating layer 4502 near the top with tapered or chamfered portions along the sides of the insulating device 4010 to provide a smaller profile on each side of the insulating device 4010.

In one example, the first portion 4502a can define a first area A_1 , and the rear top flap 4502a1 can define a second area A_2 , which is smaller than the first area A_1 . When installed between the inner liner 4500 and the outer shell 4501, the insulating layer 4502 generally follows the conical and trapezoidal shape of the profile of the insulating device 4010. Additionally, the upward tapered profile of the outer shell 4501 and the inner liner 4500 can help to position the insulating layer 4502 such that the insulating layer covers a majority of the inner liner 4500.

In particular, as shown in FIG. 21, the insulating layer 4502 occupies a majority of the space formed between the inner liner 4500 and the outer shell 4501. The insulating layer 4502 extends substantially to the top of the insulating device 4010 in both the front and the rear portions of the insulating device 4010 to insulate a majority of the compartment 4504. As a result, the insulating layer 4502 surrounds substantially the entire inner chamber 4502 to provide a maximum amount of insulation to the inner chamber 4504 of the insulating device 2010. In one example, the insulating layer 4502 covers 80% or more of the inner liner 4500 covering the inner chamber 4504, and in particular examples the insulating layer 4502 covers 85%, 90%, or 95% or more of the inner liner 4500 covering the inner chamber 4504.

In the examples discussed in relation to FIGS. 11-22, the front facing closures 2311, 4311 can be formed such that they extend a majority of the way along the front facing surface of the insulating devices 2010, 4010. As discussed above, the front-facing closures 2311, 4311 can be formed as zipper closures in accordance with the examples discussed herein. In one example, the closures 2311, 4311 can be substantially waterproof or highly water resistant and can be water tight and air tight. The front facing closures 2311, 4311 can be formed as long as possible in the front facing surface of the insulating devices 2010, 4010 to provide for extended user accessibility and visibility of the contents stored in the insulating devices 2010, 4010. In one example, the closures 2311, 4311 can define a first length L_1 , and the top portion of the insulating device 4010 can define a second length L_2 .

In one example, L_2 can be 3 cm to 10 cm longer than L_1 , the length of the front facing closures 2311, 4311 and in one specific example can be 5 cm longer than the front-facing closures 2311, 4311. The closures 2311, 4311 first length L_1 can extend at least 80% of the second length L_2 and up to 98% of the second length L_2 . In one particular example, the length of the closures 2311, 4311, L_1 can extend across 87% of the second length L_2 .

Additionally, the length L_1 of the front-facing closures 2311, 4311 can be formed longer than the length L_3 of the bases of the insulating devices 2010, 4010. In certain examples, the front facing closures 2311, 4311 can be formed approximately 1% to 25% longer than the length L_3 of the bases of the insulating devices 4010. In one specific example the length L_1 of the front facing closures 2311, 4311 can be 10% longer than the length L_3 of the bases. For example, the front-facing closures length L_1 can be formed 3 cm to 12 cm longer than the length L_3 of the bases of the insulating devices, and, in one particular example, the length L_1 of the front facing closures 2311, 4311 can be 5 cm longer than the length L_3 of the base.

In still other embodiments, the insulating device can include a closure that extends around the entire perimeter or a majority of the perimeter of the insulating device and a front facing closure **2311**, **4311** as discussed above. In this particular example, the contents of the insulating device can be easily accessed by the user once the entire or a majority of the top portion is removed or through the closure **2311**, **4311**.

In another example, the insulating device can be formed modular such that the top and/or the bottom can be removed and multiple structures can be interconnected to form larger or smaller insulating devices. For example, the insulating device can be formed of different sections by way of removable fasteners, such as snaps, zippers, threads, seals, hook and loop, and the like.

In relation to the examples discussed herein, a series of vents can be provided along the outer shells of the insulating devices. The vents allow for any gases that are trapped between the inner liner and the outer shell to escape. Without the vents, the gases trapped between the inner liner and the outer shell can cause the insulating device to expand, which in certain instances, may not be desired. In certain examples, the one or more joints or seams that connect the various portions of the outer shell provide vents for gases. Vents can be provided in areas of the outer shell where the outer shell fabric is pierced. For example, tiny openings can be provided at any of the stitching locations where the various components are located on the insulating devices. Specifically, the vents can be provided in the areas where the handles, molle loops, straps, reinforcement patches, bindings, D-rings, loop patches, etc. are attached to the outer shell of the insulating device. For example, stitching that may be used to secure these components to the outer shell provides openings into the outer shell, which creates venting between the insulation layer and the outer shell. In one specific example, the insulating device may vent through binding **4518**.

The example insulating device **4010** was tested to determine ice retention. As such, the ice retention testing may be utilized to determine insulative properties of example insulating device **4010**. In an exemplary test, the duration of the increase from 0° F. to 50° F. when the insulating device **4010** was filled with ice was determined according to the test parameters below. In certain examples, the temperature of the insulating device increases from 10° F. to 32° F. in a duration of 24 hours to 24 hours, the temperature of the insulating device increases from 32° F. to 50° F. in a duration of 36 hours to 68 hours, and the temperature of the insulating device increases from 0° F. to 50° F. in a duration of 70 hours to 90 hours.

The ice retention was tested using the following test. More than 24 hours before the test, the following steps are performed:

- Ensure test coolers are clean inside and out.
- Mark test coolers with unique identifier and record identifier and description in test log or notes.
- Using duct tape, place a thermocouple (T) in the approximate center of the test cooler (C).
- The thermocouple tip should be approximately 1 inch above the cooler floor. (See FIG. 23 for an example of proper thermocouple set-up.)
- Condition test coolers by keeping test coolers inside (ambient temperature 65-75° F.) with lids open for a minimum of 24 hours.
- Calculate the amount of ice required for testing (to nearest 0.1 lbs.) using the equation below.

Ice per cooler=0.52 lbs.xQuart capacity of cooler
Ice required=Ice per coolerxnumber of coolers
Condition the ice by placing the ice in a freezer (-15 to -5° F.) for a minimum of 24 hours prior to use.

- The day of the test, the following steps are performed:
- Gather Test Equipment
- Allow thermal chamber to reach a temperature of 100° F.
- Scale—place scale near freezer with test ice
- Data Logger—ensure Data Logger has charged battery
- The test procedure is as follows:
- Bring test coolers to freezer with test ice.
- Place test cooler on scale and tare the scale.
- Break test ice with hammer.
- Using the scale as reference, quickly fill the test cooler with the required amount of ice.
- Ensure that the ice is evenly distributed throughout the test cooler.
- Ensure that the connector end of the thermocouple is outside of the test cooler and close and secure the cooler lid.
- Repeat steps for the remaining test coolers.
- Arrange the coolers in the test area such that they all have even amounts of direct sunlight and airflow (one cooler does not block the other).
- Connect all thermocouples to the data logger.
- Check all thermocouple readings to ensure that all connections are complete and the channels are recording properly. (Note: The starting temperature inside each test cooler should be <10° F.).
- Power up the data logger and configure to record with temperatures recorded at less than 10 minute intervals.
- Begin recording and note time in test log.
- Allow the test to continue until the inside temperature of each test cooler is >50° F.
- Stop recording.
- Disconnect thermocouples from data logger.
- Receive data from data logger.
- Remove test coolers from test area.
- Empty test coolers and allow them to dry.
- Remove thermocouples from test coolers
- The heat gain rate of the insulating devices **2010**, **4010** can be approximately 0.5 to 1.5 degF/hr, and, in one particular example, the heat gain rate can be approximately 1.0 degF/hr.
- Like in the above examples, the ability of the insulating devices **2010** and **4010** are also configured to withstand interior leaks and were also tested to see how well the insulating devices **2010**, **4010** maintain the contents stored in the storage compartment or receptacles **2504**, **4504**. In one example test, the insulating devices **2010**, **4010** can be filled with a liquid, such as water, and then can be inverted for a predetermined time period to test for any moisture leaks. In this example, the insulating devices **2010**, **4010** are filled with a liquid until approximately half of a volume of the receptacle **4504** is filled, e.g. 3 gallons of water, and the closures **2301**, **4301** are then closed fully. The entire insulating devices **2010**, **4010** are then inverted and held inverted for a time period of 30 minutes. The insulating devices **2010**, **4010** are then reviewed for any leaks.
- The insulating devices **2010**, **4010** can be configured to withstand being held inverted for 30 minutes without any water escaping or leaving the receptacles **2504**, **4504**. In alternative examples, the insulating devices **2010**, **4010** can be configured to withstand being held inverted for 15 minutes to 120 minutes without any water escaping or leaving the receptacles **2504**, **4504**.

FIGS. 24-32 show another example insulating device **3010**. The example insulating device **3010** can be of a

21

similar construction to the above examples, where like reference numerals represent like features having similar functionality. In this example, as can be seen in FIGS. 24-26 and 32, the closure 3311 and opening 3512 is formed through a first sidewall 3507A, a second sidewall 3705B, and a third sidewall 3507C and partially through a fourth sidewall 3507D of the insulating device 3010. Moreover, the opening 3512 is configured to provide access to the inner chamber 3504 as is shown in FIGS. 29A and 32. Like in the above examples, the closure 3311 can be substantially waterproof so as to resist liquid from exiting the opening 3512 when the insulating device 3010 is in any orientation.

As shown in the cross-sectional view of FIG. 29A, the example insulating device 3010 generally includes a body assembly 3350 and a lid assembly 3300, which together form the three main components of the insulating device 3010: the inner liner 3500, the insulating layer 3502, and the outer shell 3501. The inner liner 3500 can, in one example, be formed of double laminated TPU nylon fabric, the insulating layer 3502 can, in one example, be formed of NBR/PVC foam blend or any other suitable blend or foam, and the outer shell 3501 can, in one example, be formed of TPU nylon fabric. It is also contemplated that the inner liner and the outer shell 3501 can be formed of one or more of PVC, TPU coated nylon, coated fabrics, and other weldable and/or waterproof fabrics.

As shown in FIGS. 24-26, the closure 3311 extends between the body assembly 3350 and the lid assembly 3300 to substantially seal the body assembly 3350 and the lid assembly 3300 from water. Additionally, as shown in FIG. 29A, the lid assembly 3300 can be connected to the body assembly 3350 by the outer shell 3501, which forms a living hinge 3503. In one example, the living hinge 3503 can be formed as a portion of the outer shell 3501 and/or the inner liner 3500 and specifically from the flexible nature of the material of the outer shell 3501 and/or the inner liner 3500 to provide a larger opening in the insulating device 3010. The living hinge 3503 can also be reinforced by an inner piece of fabric 3503A, which can be formed of the inner liner material or other waterproof materials. In this way, the chamber 3504 and contents of the insulating device 3010 can be accessed by opening the closure 3311 and folding back or opening the lid assembly 3300.

In this example, the insulating device 3010 can be in the shape of a cuboid or prism. For example, the outer shell 3501, the insulating layer 3502, and the inner liner 3500 define the first sidewall, 3507A, the second sidewall 3507B, the third sidewall 3507C, and the fourth sidewall 3507D of the cuboid. Also the lid assembly 3300 forms a top wall 3300a and the base 3215 forms a bottom wall 3215a to enclose the cuboid. However, the contents of the insulating device 3010 are accessed through the opening 3512 formed at the top of the insulating device and again can extend through each of the first sidewall, 3507A, the second sidewall 3507B, the third sidewall 3507C and can extend partly through the fourth sidewall 3507D. Other shapes are also contemplated for the insulating device 3010, for example, cylindrical, spherical, conical, pyramidal, frusto-conical, frusto-spherical, frusto-pyramidal, etc. The height of the insulating device 3010 can, in one example, be in the range of 15 cm to 50 cm and in one particular example can be 29 cm. The length of the insulating device 3010 can be in the range of 15 cm to 50 cm and in one particular example can be 32 cm. Also the width of the insulating device can, in one example, be in the range of 15 cm to 50 cm and in one specific example be 25.5 cm. The storage capacity of the insulating device 3010 can be 10 to 15 quarts and in one

22

particular example can be 12.7 quarts. However, it is contemplated that the insulating device 3010 may comprise any height, length, width and volume dimensions, without departing from the scope of these disclosures.

Like in the above examples, the insulating device 3010 can include one or more handles 3210, 3212, rings 3214, and webbing loops 3224 for attaching various items, e.g. straps (shoulder), carabineers, dry bags, keys, storage cases, etc. The rings 3214 can be b-rings, and a shoulder strap (not shown) can be connected to the D-rings for easy carrying of the insulating device. Also the rings 3214 can be attached to the insulating device 3010 at attachment points 3213, which can form loops or straps 3315a that also form a slot for receiving the rings 3214. The insulating device may also include side, front and/or rear carry handles, pockets, tie downs, and D-rings anywhere on the external surface of the outer shell. The pockets can be sized for receiving keys, phones, wallets, etc. and can be formed waterproof. The pockets may also include a waterproof zipper to prevent the contents therein from getting wet.

Likewise, similar to the above examples, the outer shell 3501 can also include multiple reinforcement areas or patches 3320 that are configured to assist in structurally supporting the optional handles, straps, and webbing loops (e.g. 3210, 3212, 3213, 3214, and 3224). The handles or straps (e.g. 3210, 3212, 3213, 3214, and 3224) and other attachments can be stitched to the patches using threads 3222. In certain examples, these threads 3222 do not extend through the outer shell 3501 into the insulating layer 3502. The optional handles or straps can be sewn to the patches 3320, and the patches 3320 can be RF welded to the outer shell 3501. Also, in other examples, the patches 3320 can be sewn or adhered to the outer shell 3501. Apertures from the stitching operation can provide venting to the interior defined by the outer shell 3501 and the inner liner 3500 of the insulating device 3010. In addition, other techniques are contemplated for securing the handles or straps to the insulating device 3010.

The internal components of the insulating device 3010, the body assembly 3350, and the lid assembly 3300 can be seen in the cross-sectional view of FIG. 29A. In addition, FIG. 29B shows a magnified cross-sectional view of the lid assembly 3300.

The lid assembly 3300 includes an upper inner liner portion 3500A, an upper insulating layer portion 3502A and an upper outer shell portion 3501A. The upper insulating layer portion 3502A can be formed of a single layer of foam, which corresponds to the overall shape of the lid assembly 3300. The foam can, in one example, be an insulating foam, as discussed herein, which can be the same foam as is used in the body assembly 3350, and can be unattached to and floating between the upper inner liner portion 3500A and the upper outer shell portion 3501A. As shown in FIG. 29B, the upper inner liner portion 3500A can be formed of a sheet of material 3500A1 and a strip of material 3500A2 that is attached to the binder 3518. In other embodiments the sheet of material 3500A1 can connect directly to the binder 3518 thus eliminating the need for the strip of material 3500A2. The strip of material 3500A2 can overlap and be welded to the sheet of material 3500A1. Seam tape 3509 can be placed over the connection between the sheet of material 3500A1 and the strip of material 3500A2. It is also contemplated that the upper inner liner portion 3500A can be formed as a unitary structure by injection molding, for example.

The upper inner liner portion 3500A can be connected to the upper outer shell portion 3501A by joining the upper inner liner strip of material 3500A2 to an upper outer shell

strip of material **3501A3** at a RF weld joint **3522**. However, it is contemplated that other types of securing methods could be used such as other forms of welding, stitching, adhesives, rivets, etc. Additionally, as will be discussed in further detail, a binding material **3518**, in the form of a strip or band can be sewn over the ends of the upper inner liner strip of material **3500A2** and the upper outer shell strip of material **3501A3**. It is also contemplated that the binding material **3518** can be coupled over the ends of the upper inner liner strip of material **3500A2** and the upper outer shell strip of material **3501A3** by a plurality of rivets, or by using one or more adhesives.

As shown in FIGS. **29A** and **29B**, the upper outer shell portion **3501A** of the lid assembly **3300** may include two separate layers **3501A1**, **3501A2** and an upper outer shell strip of material **3501A3** extending perpendicular to the two separate layers **3501A1**, **3501A2**. The upper outer shell strip of material **3501A3** can be integral and attached to a first outer shell section **3501B1** as discussed in further detail below. For example, the upper outer shell strip of material **3501A3** and the first outer shell section **3501B1** can be formed or cut from the same material. However, it is also contemplated that outer shell strip of material **3501A3** and the first outer shell section **3501B1** are formed of separate structures or different materials. In one example, the top layer **3501A1** can be formed of a TPU coated nylon laminate, and the bottom layer **3501A2** can be formed of a compression molded EVA material. The upper outer shell portion **3501A** may also be formed of a unitary piece of material in an injection molding process, for example.

As shown in FIGS. **29A** and **29B**, the binding material **3518** can both secure the lid assembly **3300** together and secure the lid assembly **3300** to the body assembly **3350**. The binding material **3518**, in certain examples, can be formed of a strip, band or ribbon and can be made of nylon. It is contemplated that the binding material **3518** can be formed from additional or alternative polymers, without departing from the scope of these disclosures. Specifically, the first outer shell section **3501B1** can be secured together with the upper inner liner **3500A**, the separate layers **3501A1**, **3501A2**, and the upper outer shell strip of material **3501A3** of the upper outer shell portion **3501A** by stitching the binding material **3518** around the perimeter of the lid assembly **3300**. The stitching, therefore, extends through the binding material **3518**, the lower outer shell portion **3501B**, the upper inner liner portion **3500A**, the top layer **3501A1**, the bottom layer **3501A2** and the strip of material **3500A2** to form a seam **3517**.

The weld joint **3522** can also both secure the lid assembly **3300** together and secure the lid assembly **3300** to the body assembly **3350**. As alluded to above, the weld joint **3522**, which can be an RF weld joint, also secures the lid assembly **3300** together by connecting the upper inner liner portion **3500A** and the upper outer shell portion **3501A** by joining the upper inner liner strip of material **3500A2** to an upper outer shell strip of material **3501A3**. It is also contemplated, however, that the joint **3522** could be formed by stitching or by an adhesive. Again once the lid assembly **3300** and the body assembly **3350** are secured together, the living hinge **3503** is formed between the lid assembly **3300** and the body assembly **3350**.

The lid assembly **3300** and the body assembly **3350** are also connected by the closure, which as discussed below, in one example, can be a zipper. Specifically, zipper tape **3306** can be attached between the upper outer shell strip of material **3501A3** and the first outer shell section **3501B1** of the lower outer shell portion **3501B** by stitching, welding,

adhesives, etc. In this way, an upper portion **3306a** and a lower portion **3306b** of the zipper tape **3306** secures the lid assembly **3300** and the body assembly **3350** together.

Referring again to FIG. **29A**, the body assembly **3350** includes lower inner liner portion **3500B**, lower insulating layer portion **3502B**, and lower outer shell portion **3501B**. The lower inner liner portion **3500B** can be formed of a top strip **3500B1**, a middle portion **3500B2**, and a bottom portion **3500B3**. The top strip **3500B1**, the middle portion **3500B2**, and the bottom portion **3500B3** can be welded or stitched together at seams **3508**. The seams **3508** can be covered with a seam tape **3509**, which can be formed of a waterproof or water resistant material, such as PU (polyurethane). However, the seam tape **3509** can be formed of a breathable material that is impervious to water but allows gases to escape from the in the inner chamber **3504**.

In an alternative example, the lower inner liner portion **3500B** can be formed of a single integral piece by, for example, injection molding. FIG. **31** shows an example inner liner portion **7500B** that is formed by an injection molding process. In this example, the lower inner liner portion **7500B** can be formed of one or more of urethane, PVC, TPU, or other weld-able material. The lower inner liner portion **7500B** can be welded into place onto the outer shell, after the lower insulating layer is placed within the outer shell.

Referring again to FIGS. **29A** and **30**, the lower insulating layer portion **3502B** can include a first sheet of insulating material **3502B1** and a second sheet of insulating material **3502B2**. Similar to the above examples, the first sheet of insulating material **3502B1** and the second sheet of insulating material **3502B2** can be free floating layers of insulating material that are not attached to either the lower inner liner portion **3500B** or the lower outer shell portion **3501B**. However, it is also contemplated that the first sheet of insulating material **3502B1** and the second sheet of insulating material **3502B2** can be attached to either the lower inner liner portion **3500B** or the lower outer shell portion **3501B**. Moreover, it is also contemplated that the lower insulating layer portion **3502B** be formed of a single unitary piece.

The lower outer shell portion **3501B** can be formed of several sections. In this example, the lower outer shell portion **3501B** can include a first outer shell section **3501B1**, a lower outer wall section **3501B2**, a first base layer **3501B3**, and a second base layer **3501B4**. Similar to the lid assembly, the first base layer **3501B3** can be formed of a TPU coated nylon laminate, and the second base layer **3501B4** can be formed of a compression molded EVA material. Each of the lower outer wall section **3501B2**, the first base layer **3501B3**, and the second base layer **3501B4** can be joined together by stitching, welding or adhesives. Also like in the above examples, a base support ridge **3400** can be formed into the first base layer **3501B3** and the second base layer **3501B4** to provide for structural integrity and support to the insulating device **3010** when the insulating device **3010** is placed onto a surface. In alternative examples, the lower outer shell portion **3501B** can be formed as a singular component and may, in certain examples, be formed by an injection molding process.

Like in the above examples, the closure **3311** can be a zipper and can be substantially waterproof. Moreover, the zipper may comprise a pull tab or handle **3302**, which in this example can be formed of a hard plastic. It is also contemplated that the pull tab **3302** can be formed of a metal or alloy, a flexible polymer, cloth, string, or rope, among others. Forming the pull tab **3302** of a cloth, string, or rope may prevent the wear of the connection between the pull tab **3302** and the

25

zipper. Specifically, when the zipper is closed about the circumference of the outer shell **3501**, the pull tab **3302** can be rotated or twisted by the user. The cloth, string, or rope can withstand the twisting action by the user. Other pull tabs are also contemplated. For example, the pull tab could be provided with a bearing connection that allows the pull tap to be rotated 360° in all directions.

A series of vents can be provided along the outer shell **3501** of the insulating device **3010**. The vents allow for any gases that are trapped between the inner liner **3500** and the outer shell **3501** to escape. Without the vents, the gases trapped between the inner liner **3500** and the outer shell **3501** will cause the insulating device **3010** to expand, which in certain instances, may not be desired. In certain examples, the joint or seams that connect the inner liner and the outer shell provides a vent to gases.

The venting can be provided in the lid assembly **3300**. Specifically in the lid assembly **3300**, the seam **3517** may provide a series of small openings in the lid assembly **3300** where the stitching on the binder material **3518** occurs. These openings act as vents for gases to escape the inner volume of the lid assembly **3300**.

Moreover, venting can be provided in the body assembly **3350**. In the body assembly, the vents can be provided in areas of the lower outer shell portion **3501B** where the lower outer shell portion **3501B** fabric is pierced. For example, as shown in FIG. 26, tiny openings can be provided at the box and cross-shaped stitching **3521** where the rear carry handle **3210** is attached to the insulating device **3010**. The vents can also be provided in the areas or locations where the handles **3212**, **3210**, molle loops **3224**, and D-rings **3214** are attached to the outer shell **3501** of the insulating device **3010**. For example, the stitching that secures the handles, webbing or molle loops **3224**, and D-rings **3214** to the outer shell provides openings into the outer shell **3501** to create venting to the storage compartment or inner chamber **3504** of the insulating device **3010**. FIG. 33 shows an example schematic where stitching **3519** extends through the outer shell **3501**, a handle **3212** a reinforcement areas or patches **3320**.

To form the insulating device **3010**, the body assembly **3350** can be formed and then the lid assembly **3300** can be formed by joining the lid assembly **3300** to the body assembly **3350**. To form the body assembly **3350** of the insulating device **3010**, the lower outer shell portion **3501B** and the lower inner liner portion **3500B** can be formed independently. Once the lower outer shell portion **3501B** is formed, the insulating layer **3502** can then be placed within the lower outer shell portion **3501B**. The lower inner liner portion **3500B** can be attached to the lower outer shell portion **3501B** to secure the insulating layer **3502** within the lower outer shell portion **3501B** and the lower inner liner portion **3500B**. However, the insulating layer **3502** can freely float between the lower outer shell portion **3501B** and the lower inner liner portion **3500B**. The lid assembly **3300** can be secured together and the lid assembly **3300** can be secured to the body assembly **3350** by welding the upper inner liner portion **3500A** to the upper outer shell portion **3501A** and the lower outer shell portion **3501B** at the weld joint **3522**. Finally, the lid assembly **3300** can be further attached to the lower outer shell portion **3501B** by way of stitching the top portion of the lower outer shell portion **3501B** together with the top layer **3501A1**, the bottom layer **3501A2**, the upper inner liner portion **3500A**, the strip of material **3501A3**, and the binding material **3518**.

Specifically, the lower outer shell portion **3501B** can be formed by attaching each of the first outer shell section

26

3501B1, the lower outer wall section **3501B2**, the first base layer **3501B3**, and the second base layer **3501B4** together. Next, each of the first sheet of insulating material **3502B1** and the second sheet of insulating material **3502B2** can be placed within the lower outer shell portion **3501B**. The lower inner liner portion **3500B** can then be formed by welding each of the top strip **3500B1**, the middle portion **3500B2**, and the bottom portion **3500B3** together and then by adding the seam tape **3509** over each of the welds. Alternatively, as discussed above, the lower inner liner portion **3500B** can be formed by injection molding the material. Once the lower inner liner portion **3500B** is formed, the inner liner portion **3500B** can be placed within the lower insulating layer portion **3502B**, and the inner liner portion **3500B** can be welded to the lower outer shell portion **3501B** at seam **3511** all along the inner perimeter of the body assembly **3350** of the insulating device **3010**. The seam **3511** can be formed in this example by either welding or stitching.

FIG. 9 shows an exemplary welding technique that can be used to weld the lower inner liner portion **3500B** to the lower outer shell portion **3501B**. Once the lower inner liner portion **3500B** is placed within the lower insulating layer portion **3502B**, the lower inner liner portion **3500B** can then be joined to the lower outer shell portion **3501B** on its side using a three-piece tool, which can include a top U-shaped portion **3514A**, a plate portion **3516**, and a bottom U-shaped portion **3514B**. The curvature of the top U-shaped portion **3514A**, the plate portion **3516**, and the bottom U-shaped portion **3514B**, can correspond to the shape of the perimeter of the body assembly **3350** of the insulating device **3010**.

To form the seam **3511** as a weld, the lower inner liner portion **3500B** is placed into contact with the lower outer shell portion **3501B** and the plate portion **3516** is placed within the lower inner liner portion **3500B** and the top U-shaped portion **3514A**, and the bottom U-shaped portion **3514B** can be placed into contact with lower outer shell portion **3501B**. The top U-shaped portion **3514A** and the bottom U-shaped portion **3514B** can be connected to two lead wires such that current can pass through the top U-shaped portion **3514A**, the lower outer shell portion **3501B** and the lower inner liner portion **3500B**. Current can then be applied first to the top U-shaped portion **3514A** to form a weld along the top U-shaped portion **3514A** including the curves and the straight portions. After the top section is welded, the polarity of the lead wires can then be reversed to then weld the bottom section along the bottom U-shaped portion **3514B**.

After the bottom section is welded by the bottom U-shaped portion the remaining two sides can then be welded by using the plate portion **3516** and a pair of straight side bars or another clamping mechanism or vice. Similar to the curved portions of the body assembly **3350**, current can be applied to the pair of straight side bars by lead wires. Again, the sides can be welded separately by applying the current in a first direction to weld a first side and by then switching polarity of the leads and running the current in the opposite direction to weld a second side. In one example, each of the sections can be welded for approximately 10 seconds. Once the weld is complete around the entire perimeter of the body assembly **3350**, the body assembly **3350** can be assembled to the lid assembly **3300**.

In one example, the closure **3311** can be substantially waterproof so as to resist liquid from exiting the opening when the insulating device is dropped from a distance of six feet. In this test, the insulating device can be filled completely with water and then dropped from six feet onto a

concrete surface on each of the faces of the insulating device **3010**, which in this case is six.

The example insulating device **3010** was tested to determine ice retention. As such, the ice retention testing may be utilized to determine insulative properties of example insulating device **3010**. In an exemplary test, the duration of the increase from 0° F. to 50° F. when the insulating device **3010** was filled with ice was determined according to the test parameters below. In certain examples, the temperature of the insulating device increases from 0° F. to 10° F. in a duration of 0.5 hours to 1.5 hours, the temperature of the insulating device increases from 10° F. to 50° F. in a duration of 22 hours to 28 hours, and the temperature of the insulating device increases from 0° F. to 50° F. in a duration of 24 hours to 30 hours.

The ice retention was tested using the following test. More than 24 hours before the test, the following steps are performed:

Ensure test coolers are clean inside and out.

Mark test coolers with unique identifier and record identifier and description in test log or notes.

Using duct tape, place a thermocouple (T) in the approximate center of the test cooler (C).

The thermocouple tip should be approximately 1 inch above the cooler floor. (See FIG. 11 for an example of proper thermocouple set-up.)

Condition test coolers by keeping test coolers inside (ambient temperature 65-75° F.) with lids open for a minimum of 24 hours.

Calculate the amount of ice required for testing (to nearest 0.1 lbs.) using the equation below.

$$\text{Ice per cooler} = 0.52 \text{ lbs.} \times \text{Quart capacity of cooler}$$

$$\text{Ice required} = \text{Ice per cooler} \times \text{number of coolers}$$

Condition the ice by placing the ice in a freezer (-15 to -5° F.) for a minimum of 24 hours prior to use.

The day of the test, the following steps are performed:

Gather Test Equipment

Allow thermal chamber to reach a temperature of 100° F.

Scale—place scale near freezer with test ice

Data Logger—ensure Data Logger has charged battery

The test procedure is as follows:

Bring test coolers to freezer with test ice.

Place test cooler on scale and tare the scale.

Break test ice with hammer.

Using the scale as reference, quickly fill the test cooler with the required amount of ice.

Ensure that the ice is evenly distributed throughout the test cooler.

Ensure that the connector end of the thermocouple is outside of the test cooler and close and secure the cooler lid.

Repeat steps for the remaining test coolers.

Arrange the coolers in the test area such that they all have even amounts of direct sunlight and airflow (one cooler does not block the other).

Connect all thermocouples to the data logger.

Check all thermocouple readings to ensure that all connections are complete and the channels are recording properly. (Note: The starting temperature inside each test cooler should be <10° F.).

Power up the data logger and configure to record with temperatures recorded at less than 10 minute intervals.

Begin recording and note time in test log.

Allow the test to continue until the inside temperature of each test cooler is >50° F.

Stop recording.

Disconnect thermocouples from data logger.

Receive data from data logger.

Remove test coolers from test area.

Empty test coolers and allow them to dry.

Remove thermocouples from test coolers

Two samples were tested according to the above procedure. The results of which are reflected below.

	Time from 0° F. to 10° F.	Time from 0° F. to 50° F.			Time from 10° F. to 50° F.		
	Time (mins.)	Days	Hrs	Min	Days	Hrs	Min
Test #1	53	1	3	53	1	3	0
Test #2	49	1	3	37	1	2	48

FIGS. 35A-36B show various views of another exemplary insulating device **5010**. The example insulating device **5010** is similar to the example discussed above in relation to FIGS. 24-30. Like reference numerals refer to the same or similar elements of similar functionality in all of the various views; and, therefore, these elements are not described in detail. However, in this example the exemplary insulating device **5010** can be formed of a smaller size, can include a top handle **5216**, and may include an optional reinforcement sheet or panel. Nevertheless, it is contemplated that the insulating device examples discussed herein could include a similar top handle and reinforcement sheet or panel.

FIGS. 36A and 36B show a partial view of an example lid assembly **5300**. FIG. 35A shows a partial cross-section view of the example lid assembly **5300**. The example lid assembly **5300** is similar to the examples above, however, can additionally include a reinforcement sheet or panel **5217** in the lid assembly **5300**. FIG. 36B shows a partial top view of the example lid assembly to illustrate the reinforcement sheet **5217**. The reinforcement sheet or panel **5217** is configured to assist in preventing bowing of the handle **5216** and the lid assembly **5300**. The reinforcement sheet or panel **5217** can be a relatively rigid sheet of material in comparison to the outer liner **5501**, insulating layer **5502**, and the inner layer **5500**. In one particular example, the reinforcement sheet or panel **5217** can be formed of a suitable polymer or plastic, such as polyethylene. However, any stiffener material that is flexible could be used and other examples, may include a thermoformed PE, a TPU injection molded custom component.

In certain examples, the reinforcement sheet or panel **5217** can be flat, corrugated or may have a honey comb configuration. The panel **5217**, however, can include other patterns so as to assist in preventing bowing of the handle **5216**. In certain examples, the reinforcement sheet or panel can be 1 to 3 mm thick. The reinforcement sheet may include a cover, which can in certain examples, can be configured to prevent water from penetrating the cover. In other examples, additional fabric may be included to reinforce the handle.

A reinforcement area or patch **5320** can be included on the lid assembly **5300** for supporting the handle **5216**. In certain examples, the patch **5320** can be welded to the lid assembly **5300**. However, the patch **5320** may also be omitted entirely. The handle **5216** may be sewn to the lid assembly **5300** and the reinforcement panel **5217** by way of thread **5219**. The handle **5216** may also extend through the lid assembly and be directed connected to the reinforcement panel **5217**. In addition, instead of using a thread, the handle **5216** can be connected to the reinforcement sheet or panel **5217** by one or more welds, bolts or other threaded-like connection, bayonet, ball and socket, and the like. Other connection

methods may include providing either layers **5501A1** or **5501A2** with one or more slots and the reinforcement sheet or panel **5217** with one or more corresponding projections that can be located within the one or more slots, which allow for a more advanced connection of the sheet or panel **5217** to the lid assembly **5300** of the insulating device **5010**. Also a wireframe or steel wire can be placed within the handle **5216** and extend through the handle **5216**. The wireframe or steel wire can be threaded through the sheet or panel **5217** to secure the handle to the lid assembly **5300**. It is also contemplated that all or portions of the lid assembly and/or handle can be injection molded to provide a more rigid structure to prevent bowing of the handle.

The connection between the handle **5216** and the reinforcement panel **5217** also helps prevent separation issues between the separate layers **5501A1**, **5501A2**, which can be a TPU coated nylon laminate, and a compression molded EVA material respectively. In this example, the connection between the handle and the reinforcement panel may allow water into the lid. However, at the same time, the connection can allow for any liquid therein to escape by evaporating through the opening formed by the connection. However, it is also contemplated that the connection between the handle and the reinforcement panel may also be waterproof or water resistant to limit the amount of moisture into the lid assembly.

Also the handle **5216** can be formed of a 1000D Nylon or other suitable polymer and may include 50 mm webbing. Additionally, the handle **5216** may include padding on the gripping portion of the handle. In one example, the padding may be a suitable foam, such as a 5 mm polyethylene sponge foam. It is contemplated that the seal between the lid assembly **5300** and the body assembly **5350** can be configured to withstand shock loading by the handle when the insulating device **5010** is sealed and filled with contents. Nevertheless, a side bridge linking the lid assembly **5300** to the body assembly **5350** is also contemplated for transporting heavy items in the insulating device **5010**.

An exemplary insulating device may include an outer shell, an inner liner, an insulating layer floating freely in between the outer shell and the inner liner, and a waterproof closure. The top of the shell has first perimeter circumference, and the bottom of the shell has a second perimeter circumference. The first perimeter circumference can be equal to the second perimeter circumference. The closure can be a zipper assembly comprising a plurality of zipper teeth, and the zipper teeth can be formed of plastic or metal. The outer shell can be made of a double laminated TPU nylon fabric. The inner liner can be made of a double laminated TPU nylon fabric. The insulating layer can be formed of a closed cell foam. The insulating layer can be made of a NBR and a PVC blend, and at least a portion of the insulating layer can be constructed with an EVA foam layer. The outer shell further can include at least one of a strap or handle. The outer shell further can include at least one ring for securing the insulating device.

An exemplary insulating device can include an outer shell, an inner liner, a closure adapted to seal at least one of the outer shell or the inner liner, and an insulating layer between the outer shell and the inner liner. The closure can have a first flange and a second flange, and the outer liner can be secured to top surfaces of the first flange and the second flange and the inner liner can be secured to bottom surfaces of the first flange and the second flange. The outer liner and the inner liner can be connected to the closure by a polymer weld. The outer shell can have a first circumference and a second circumference, the first circumference and

the second circumference both having an oval shape. The closure can be adapted to be a barrier against fluid. The closure can be a zipper apparatus that is watertight up to 7 psi above atmospheric pressure.

An exemplary method of assembling a insulating device may include forming an inner liner having an inner vessel, forming an outer shell, forming an insulating layer between the inner liner and the outer shell, and securing a closure configured to be a barrier against fluid penetration in and out of the inner vessel wherein the closure is secured in a flat plane and is secured to the outer shell and the inner shell. The outer shell and inner shell may only be connected to the closure and not to the insulating layer between the outer shell and inner liner.

A waterproof polymer weld can be formed between the closure and the inner shell and the closure and the outer shell when the closure, the outer shell, and the inner liner are lying in a horizontal plane. The outer shell and the inner layer can be formed of a TPU nylon material. The closure can have a first flange and a second flange. The outer liner can be secured to top surfaces of the first flange and the second flange and the inner liner can be secured to bottom surfaces of the first flange and the second flange.

The method can also include forming the insulating layer from a rectangular shape, and rolling the rectangular shape into a cylindrical shape. The top of the insulating layer has a first perimeter circumference and the bottom of the insulating layer has a second perimeter circumference. The first perimeter circumference can be equal to the second perimeter circumference.

Another example insulating device can include an outer shell, an inner liner forming a storage compartment, a foam layer floating freely in between the outer and inner liner, the foam layer providing insulation, an opening extending through the outer layer and the inner layer, and a closure adapted to substantially seal the opening. The closure can be substantially waterproof so as to resist liquid from exiting the opening.

The insulating device can also include an upper wall and a base, the upper wall defining an upper wall circumference, an upper wall length and an upper wall width, and the base defining a base circumference, a base length and a base width. The upper wall circumference can be equal to the base circumference and the ratio of the upper wall length to the upper wall width can be greater than the ratio of the base length to the base width. In one example, a heat gain rate of the insulating device can be approximately 1.0-1.5 degF/hr.

Another example method of forming an insulating device may include forming an inner liner first portion and an outer shell first portion, securing the inner liner first portion and the outer shell first portion to a sealable closure to form a cap assembly, forming an inner liner second portion and securing the inner liner second portion to the inner liner first portion to form an inner liner, forming an outer shell second portion, rolling a rectangular foam portion to form a first cylindrical foam portion and securing a foam base portion to the first cylindrical portion to form a foam assembly, inserting the foam assembly into the outer shell second portion, inserting the inner liner into the foam assembly, and stitching the outer shell first portion to the outer shell second portion. The inner liner first portion and the outer shell first portion can be welded to the closure. The closure can be provided with at least one flange and the flange can be secured to a bottom surface of the outer shell first portion and a top surface of the inner liner first portion. The foam can float between the outer shell second portion and the inner liner second portion.

An example portable insulating device may include an outer liner, an inner liner forming a storage compartment, a foam layer in between the outer and inner liner. The foam layer can be adapted to provide insulation. The example portable insulating device may also include an opening extending through one of the outer layer and the inner layer and a closing means for substantially sealing the opening. The closure can be substantially waterproof.

In one example, a portable cooler may include an aperture on the top of the cooler that is opened and closed by a zipper apparatus which allows access to a chamber within the cooler. The aperture prevents any fluid leakage out of the cooler if the cooler is overturned or in any configuration other than upright. The zipper assembly also prevents any fluid from permeating into the cooler chamber if the cooler is exposed to precipitation, other fluid, or submersed under water.

An example method of assembling a zipper apparatus and aperture configured to be impervious to water or other liquids and fluids can include attachment of a waterproof zipper via material welding to both an outer shell and an inner liner. This method may result in a chamber impervious to water and other liquids when the zipper apparatus on the aperture is sealed.

In one example, an insulating device may include an outer shell, an inner liner forming a storage compartment, a foam layer floating formed in between the outer and inner liner, the foam layer providing insulation, an opening extending through the outer layer and the inner layer, a closure adapted to substantially seal the opening, the closure being substantially waterproof so as to resist liquid from exiting the opening when the insulating device is in any orientation. In one example, the top portion of the outer shell can have a first perimeter circumference in a first configuration. The outer shell may include a bottom portion, the bottom portion of the outer shell can have a second perimeter circumference in a second configuration that is different from the first configuration, and the first perimeter circumference can be equal to the second perimeter circumference. The first configuration and the second configuration can be both oval shaped. In one example, the insulating device may include an upper wall and a base, the upper wall can define an upper wall circumference, an upper wall length and an upper wall width, and the base can define a base circumference, a base length and a base width. The upper wall circumference can be equal to the base circumference and the ratio of the upper wall length to the upper wall width can be greater than the ratio of the base length to the base width. The cold retention time of the insulating device can be approximately 11 to 20 hours. However, in one example the cold retention time can be 11 to 15 hours. In another example the cold retention time can be approximately 12.24 hours. The heat gain rate of the insulating device can be approximately 1 to 1.5 degF/hr, and, in one particular example, the heat gain rate can be approximately 1.4 degF/hr. The storage compartment can be configured to maintain a liquid therein while inverted for greater than 15 minutes. In one particular example, the storage compartment can be configured to maintain the liquid for a period of greater than 30 minutes therein when inverted and a half of a volume of the storage compartment is filled with the liquid.

In one example, the insulating layer can be floating freely in between the outer shell and the inner liner. The insulating layer can be formed of closed cell foam, and the insulating layer can be made of a NBR and a PVC blend. In one example least a portion of the insulating layer can be constructed with an EVA foam layer. The closure can be a

zipper assembly comprising a plurality of zipper teeth, and the zipper teeth can be formed of plastic.

In one example, the outer shell and the inner liner can be made of a double laminated TPU nylon fabric. The outer shell further can include at least one of a strap or handle. The outer shell can include at least one ring for securing the insulating device. The insulating layer can be configured to maintain an internal temperature of the insulating device below 50 degrees Fahrenheit for 65 to 85 hours. The closure can be formed with a first flange and a second flange and the outer liner can be secured to top surfaces of the first flange and the second flange. The inner liner can be secured to bottom surfaces of the first flange and the second flange. The outer liner and the inner liner can be connected to the closure by a polymer weld. In one example, the closure can be watertight up to 2 to 14 psi above atmospheric pressure. A loop patch may also be provided on the insulating device.

In another example, an insulating device may include an outer shell, an inner liner forming a storage compartment, a foam layer floating in between the outer and inner liner, which provides insulation, an opening extending through the outer layer and the inner layer, a closure adapted to substantially seal the opening. The closure can be substantially waterproof so as to prevent liquid from exiting the opening when the insulating device is inverted for a period of greater than 15 minutes. The heat gain rate of the insulating device can be approximately 1.0 to 1.5 degF/hr. The insulating device can include at least one handle. The at least one handle can be configured to support 100 lbs. to 300 lbs. of weight for 1 to 10 minutes without showing signs of failure. In one example, the insulating device can be configured to withstand 35 lbs. to 100 lbs. of puncture force.

An example method of forming an insulating device can include forming an inner liner first portion and an outer shell first portion, securing the inner liner first portion and the outer shell first portion to a sealable closure to form a cap assembly, forming an inner liner second portion and securing the inner liner second portion to the inner liner first portion to form an inner liner, forming an outer shell second portion, rolling a rectangular foam portion to form a first cylindrical foam portion and securing a foam base portion to the first cylindrical foam portion to form a foam assembly, inserting the foam assembly into the outer shell second portion, inserting the inner liner into the foam assembly, and securing the outer shell first portion to the outer shell second portion to form the outer shell. The method may also include securing a closure configured to be a barrier against fluid penetration in and out of the inner vessel and forming a waterproof polymer weld between the closure and the inner shell and the closure and the outer shell when the closure, the outer shell, and the inner liner are lying in a flat plane.

In an example, the inner liner first portion and the outer shell first portion can be secured to the closure. The closure can be provided with at least one flange, and the flange can be secured to a bottom surface of the outer shell first portion and a top surface of the inner liner first portion. The foam can freely float between the outer shell second portion and the inner liner second portion. The outer shell and inner shell are only connected to the closure and not to the insulating layer between the outer shell and inner liner. The outer shell can be formed of a TPU nylon material, and the inner liner can be formed from a TPU nylon material. The closure can include a first flange and a second flange. The outer liner can be secured to top surfaces of the first flange and the second flange, and the inner liner can be secured to bottom surfaces of the first flange and the second flange. The top of the insulating layer can have a first perimeter circumference.

The bottom of the insulating layer can have a second perimeter circumference. The first perimeter circumference can be equal to the second perimeter circumference.

In one example, an insulating device can include an outer shell defining a sidewall, an inner liner forming a storage compartment, an insulating layer positioned in between the outer shell and the inner liner, the insulating layer providing insulation for the storage compartment, an opening extending through the outer shell and the inner liner, and a closure adapted to substantially seal the opening, the closure being substantially waterproof so as to resist liquid from exiting the opening when the insulating device is in any orientation. The insulating device may include a vertically extending front facing surface and the closure can be located on the front facing surface. A cross section of the insulating device can approximate a pentagon in an extended position, and a cross section of the insulating device can approximate a trapezoid in an extended position. The insulating device may also include a base, and the insulating layer can insulate the base. The base may also include an additional insulating layer.

The insulating device may also include a fold-down portion configured to cover the closure. The fold-down portion comprising a first section and a second section and wherein the first section is free of the insulation layer and the second section includes the insulation layer. The fold-down portion can be at least partially free of foam. The fold-down portion can be configured to be secured to the sidewall. The fold-down portion can include at least one hook and the sidewall can include at least one loop. The hook can be configured to engage the loop to secure the fold-down portion to the sidewall. The fold-down portion can be secured to the sidewall, and the fold-down portion may extend at least partly in a substantially horizontal direction. The fold-down portion may define a first width, and the closure extends across at least 95% of the first width. The fold-down portion may also include a handle configured to be grasped by a user when the fold-down portion is secured to the sidewall.

The insulating layer may include a foam material. The insulating layer may include a first portion and a second portion, and the second portion can be formed thicker than the first portion. The insulating layer can be at least partly formed in a shape of a T. The insulating layer can be at least partly formed of a first rectangle and a second rectangle and the first rectangle can have a larger area than the second rectangle. The first rectangle can have a first rectangle width and the second rectangle can have a second rectangle perimeter. The first rectangle width can approximate the second rectangle perimeter. The second rectangle can extend into the fold-down portion. The insulating layer can have a first height and a second height and the first height can be greater than the second height. A majority of the insulating layer can extend to the second height.

A method of forming an insulating device may include forming an inner liner defining a storage compartment, forming an outer shell defining a sidewall, placing an insulating layer in between the outer shell and the inner liner, the insulating layer providing insulation for the storage compartment, placing an opening in the inner liner and the outer shell, and placing a closure between the inner liner and the outer shell. The closure can be adapted to substantially seal the opening, and the closure can be substantially waterproof so as to resist liquid from exiting the opening when the insulating device is in any orientation. The method may also include forming a fold-down portion configured to cover the closure, providing the fold-down portion with a first section

and a second section. The first section can be free of the insulation layer and the second section can include the insulation layer. The fold-down portion can be at least partially free of foam. The fold-down portion can be configured to secure to the sidewall. The method may also include forming the insulating layer at least partly in the shape of a T, forming the insulating layer at least partly of a first rectangle and a second rectangle, and forming the first rectangle of a larger area than the second rectangle. The method may also include extending the second rectangle into the fold-down portion and providing the insulating layer on a base and providing an additional insulating layer along the base.

In another example, an insulating device can include an outer shell defining a sidewall, an inner liner forming a storage compartment, and an insulating layer positioned in between the outer shell and the inner liner. The insulating layer can provide insulation for the storage compartment. The insulating device can include an opening configured to allow access to the storage compartment and a closure adapted to substantially seal the opening. The insulating device can include a binding material, and the binding material can be placed over a joint between the inner liner and the outer shell. The binding material can be stitched onto the insulating device, and the stitching can create openings into the outer shell for venting air trapped between the insulating layer and the outer shell. The binding material can create at least one strap for holding the insulating device. The binding material can include a first folded portion attached to the outer shell and a second folded portion, and the second folded portion can form a strap.

The insulation device can approximate a trapezoid from a front view and can approximate a conical shape from a side view. In one example, the insulating device increases from 0° F. to 50° F. in a duration of 70 hours or greater when filled with 0.52 lbs. of ice per each quart in capacity of the insulating device.

The closure can be substantially waterproof so as to resist liquid from exiting the opening when the insulating device is in any orientation. In one example, the insulating device can be configured to withstand being held inverted for 15 minutes without any water escaping or leaving the storage compartment. The closure can be configured to stay in the opened position when the closure is not sealed. The closure can be a zipper. In one example, the closure extends at least 80% of the length of the insulating device when measured along the closure. The length of the closure can be longer than the length of the bottom of the insulating device, and the length of the closure is at least 5% longer than the length of the bottom of the insulating device. The insulating device can include a vertically extending front facing surface, and the closure can be located on the front facing surface. A handle can be located on a rear facing surface opposing the front facing surface.

In the example insulating device, the insulating layer can comprise a foam material. The insulating layer can comprise a first portion and a second portion, and the second portion can be formed thicker than the first portion. The insulating layer can be at least partly formed of a first rectangle and a second rectangle, and the first rectangle can have a larger area than the second rectangle. The insulating layer can have a first height and a second height, and the first height can be greater than the second height. In one example, a majority of the insulating layer can extend to the second height. In addition or alternatively, the front of the insulating layer can extend to the second height and the rear of the insulating layer extends to the first height. The insulating device can

include a base, and the insulating layer can insulate the base. Also the base can include an additional or separate insulating layer. In one example, the insulating layer can cover 80% or more of the inner liner covering the storage compartment or the insulating layer can cover 90% or more of the inner liner covering the storage compartment.

In another example, a method of forming an insulating device may include forming an inner liner the inner liner defining a storage compartment, forming an outer shell defining a sidewall, placing an insulating layer in between the outer shell and the inner liner, the insulating layer providing insulation for the storage compartment, placing an opening in the inner liner and the outer shell, placing a closure between the inner liner and the outer shell, the closure adapted to substantially seal the opening, the closure being substantially waterproof so as to resist liquid from exiting the opening when the insulating device is in any orientation. The method can also include forming the insulating layer at least partly of a first rectangle and a second rectangle and forming the first rectangle of a larger area than the second rectangle. The method can also include providing the insulating layer on a base and providing an additional insulating layer along the base.

An example insulating device can include an outer shell defining a first sidewall; an inner liner forming a storage compartment; an insulating layer positioned in between the outer shell and the inner liner, the insulating layer providing insulation for the storage compartment. The outer shell and the inner liner can define an opening, and the opening can be configured to allow access to the storage compartment. A closure can be adapted to substantially seal the opening, and the closure can be substantially waterproof so as to resist liquid from exiting the opening when the insulating device is in any orientation. The outer shell may include a second sidewall and a third sidewall, and the opening may extend through the first sidewall, the second sidewall, and the third sidewall. The insulating device can be in the shape of a cuboid. The inner liner and the outer shell can form a joint, and the joint can include a vent to gases that become trapped between the inner liner and the outer shell. The outer shell may include one or more handles, and a vent can be formed adjacent to a location of the one or more handles. The closure can be substantially waterproof so as to resist liquid from exiting the opening when the insulating device is dropped from a distance of six feet.

The insulating device can also include a lid assembly and a body assembly. The lid assembly and the body assembly can together form the inner liner, the insulating layer, and the outer shell. The lid assembly can include at least a portion of the insulation layer. The lid assembly may also include a handle and a reinforcement layer that is more rigid than the inner liner, the insulating layer, and the outer shell.

The outer shell may define a bottom wall extending in a first plane, and the inner liner can be secured to the outer shell in a second plane extending perpendicular to the first plane. The liner may be formed of a first piece and a second piece and the first piece is joined to the second piece by way of a weld to define a seam and the seam may be covered with a seam tape. In one alternative example, the inner liner can be formed by way of injection molding. The closure can be a zipper and can be substantially waterproof. The zipper can include a pull, and the pull can be formed of a cloth, string, or rope. In certain examples, the temperature of the insulating device increases from 0° F. to 10° F. in a duration of 0.5 hours to 1.5 hours, the temperature of the insulating device increases from 10° F. to 50° F. in a duration of 22 hours to

28 hours, and the temperature of the insulating device increases from 0° F. to 50° F. in a duration of 24 hours to 30 hours.

An example method may include forming a body assembly by forming a lower outer shell, placing a lower insulating layer into the lower outer shell, and securing a lower inner liner portion to the lower outer shell; forming a lid assembly of an upper outer shell, an upper inner liner portion and an upper insulating layer therebetween; and joining the lid assembly to the body assembly by securing a closure between the lid assembly and the body assembly and by securing a binding material to the body assembly and the lid assembly. The insulating layer can float between the lower outer shell and the lower inner liner portion. The binding material can be formed of nylon, and the binding material can be stitched to the body assembly and the lid assembly. The lid assembly may also be welded to the body assembly. Additionally, the lid assembly may be formed with a handle and a reinforcement layer that is more rigid than the inner liner, the insulating layer, and the outer shell. The lower inner liner portion in certain examples can be formed by injection molding.

The lower inner liner portion can be secured to the lower outer shell by a weld. The weld can be formed by clamping the lower outer shell to the lower inner liner portion with a top U-shaped portion, a plate portion, and a bottom U-shaped portion and applying a current through the top U-shaped portion, the plate portion, and the bottom U-shaped portion. The current can be applied through the top U-shaped portion, the plate portion, and the bottom U-shaped portion in a first direction to weld a first side and the current can be applied in a second direction to weld a second side.

The present invention is disclosed above and in the accompanying drawings with reference to a variety of examples. The purpose served by the disclosure, however, is to provide examples of the various features and concepts related to the invention, not to limit the scope of the invention. One skilled in the relevant art will recognize that numerous variations and modifications may be made to the examples described above without departing from the scope of the present invention.

What is claimed is:

1. An insulating device comprising:

- an outer shell;
- an inner liner forming a storage compartment;
- an insulating layer positioned in between the outer shell and the inner liner, wherein the insulating layer provides insulation for the storage compartment, and wherein the insulating layer is an unattached foam layer;
- an opening configured to allow access to the storage compartment; and
- a closure adapted to substantially seal the opening, wherein the closure is substantially waterproof so as to resist liquid from exiting the opening when the insulating device is in any orientation, wherein the insulating device further comprises a lid assembly, and wherein the lid assembly includes:
 - a lid assembly outer shell,
 - a lid assembly reinforcement patch,
 - a lid assembly reinforcement panel,
 - a lid assembly insulating layer,
 - a lid assembly inner liner, and
 - a top handle,

37

wherein the top handle extends horizontally when the insulating device is in an upright position and the closure is in the closed position, wherein the lid assembly reinforcement patch defines a first area, wherein the lid assembly reinforcement panel extends parallel to the top handle, wherein the lid assembly reinforcement panel defines a second area, wherein the lid assembly reinforcement panel is more rigid than the lid assembly inner liner and the lid assembly reinforcement panel is more rigid than the lid assembly outer shell, wherein the top handle is sewn to the lid assembly, wherein the lid assembly reinforcement patch is positioned between the top handle and an upper surface of the lid assembly outer shell, wherein the lid assembly reinforcement patch is secured to the upper surface of the lid assembly outer shell with an adhesive or welding, wherein the lid assembly reinforcement panel is positioned below a lower surface of the lid assembly outer shell, and wherein the second area is greater than the first area such that the lid assembly reinforcement panel is configured to assist in preventing the lid assembly from bowing when the insulating device is carried in an upright position.

2. The insulating device of claim 1, wherein the insulating device further comprises at least two side handles, wherein the side handles are sewn to side reinforcement patches, and wherein the side reinforcement patches are attached to the outer shell.

3. The insulating device of claim 1, wherein the insulating device further comprises at least two side rings configured for the attachment of items, wherein the rings are engaged with attachment points, wherein the attachment points are sewn to side reinforcement patches.

4. The insulating device of claim 3, wherein the insulating device is substantially in a shape of a cuboid.

5. The insulating device of claim 4, wherein the lid assembly reinforcement panel has a thickness between 1 mm to 3 mm.

6. The insulating device of claim 1, wherein the lid assembly insulating layer is positioned below the lid assembly reinforcement panel.

7. The insulating device of claim 1, wherein the closure is a substantially waterproof zipper, and wherein the zipper comprises a zipper pull and wherein the zipper pull comprises a first portion and a second portion.

8. The insulating device of claim 7, wherein the zipper pull second portion forms a handle for a user to grasp, and wherein the second portion is substantially perpendicular to the first portion.

9. An insulating device comprising:

a body assembly comprising an outer shell defining a first sidewall, a second sidewall, a third sidewall, and a fourth sidewall;

an inner liner forming a storage compartment;

an insulating layer positioned in between the outer shell and the inner liner, the insulating layer providing insulation for the storage compartment;

at least two side handles,

wherein the side handles are positioned on an upper portion of the outer shell,

wherein the side handles are sewn to reinforcement patches, and

38

wherein the reinforcement patches are affixed to the outer shell with an adhesive or welding; an opening configured to allow access to the storage compartment;

a closure adapted to substantially seal the opening, wherein the closure is a zipper being substantially waterproof so as to resist liquid from exiting the opening when the insulating device is in any orientation; and

a lid assembly,

wherein the lid assembly and the body assembly are secured together by a living hinge,

wherein the lid assembly further comprises:

a lid assembly outer shell,

a lid assembly reinforcement panel,

a lid assembly inner liner, and

a top handle,

wherein the top handle is sewn to a reinforcement patch,

wherein the reinforcement patch is affixed to an upper surface of the lid assembly outer shell with an adhesive or welding,

wherein the lid assembly reinforcement panel is more rigid than the outer shell and the lid assembly reinforcement panel is more rigid than the inner liner,

wherein the lid assembly reinforcement panel is positioned below the lid assembly outer shell, and

wherein the lid assembly reinforcement panel is configured to assist in preventing the lid assembly from bowing when the insulating device is carried in an upright position.

10. The insulating device of claim 9, wherein the insulating device further comprises a plurality of rings configured for the attachment of items, and wherein the rings are engaged with attachment points.

11. The insulating device of claim 9, wherein the insulating layer is not attached to the inner liner or the outer shell.

12. The insulating device of claim 9, wherein the insulating layer is attached to the inner liner or the outer shell.

13. The insulating device of claim 9, wherein the insulating layer floats between the inner liner and the outer shell.

14. The insulating device of claim 9 further comprising at least one base insulating layer, wherein the at least one base insulating layer is attached to the outer shell or the insulating layer.

15. The insulating device of claim 9, wherein the lid assembly further includes a lid assembly insulating layer positioned below the lid assembly reinforcement panel.

16. The insulating device of claim 9, wherein the lid assembly further includes a lid assembly insulating layer positioned below the lid assembly reinforcement panel, and wherein the lid assembly insulating layer is not attached to the lid assembly inner liner or the lid assembly outer shell.

17. The insulating device of claim 9, wherein the lid assembly further includes a lid assembly insulating layer positioned below the lid assembly reinforcement panel, and wherein the lid assembly insulating layer is attached to the lid assembly inner liner or the lid assembly outer shell.

18. The insulating device of claim 9 further comprising a base, wherein the base is more rigid than the outer shell and the base is more rigid than the inner liner, and wherein the base includes a molded logo or name on a bottom surface.

39

- 19. An insulating device comprising:
 - a body assembly comprising:
 - an outer shell;
 - an inner liner forming a storage compartment;
 - an insulating layer positioned in between the outer shell and the inner liner;
 - a base,
 - wherein the base is compression molded;
 - an opening configured to allow access to the storage compartment; and
 - a closure adapted to substantially seal the opening,
 - wherein the closure is substantially waterproof so as to resist liquid from exiting the opening when the insulating device is in any orientation; and
 - a lid assembly,
 - wherein the lid assembly and the body assembly are secured together by a living hinge,
 - wherein the lid assembly further comprises a reinforcement panel, and a top handle,
 - wherein the top handle comprises:
 - a first attachment area,
 - a second attachment area, and
 - a middle portion,
 - wherein the first attachment area and the second attachment area of the top handle include a stitching pattern defining an X, and
 - wherein a top of the middle portion of the top handle includes a stitching pattern defining a rectangle,
 - wherein the reinforcement panel is more rigid than the inner liner, and the reinforcement panel is more rigid than the outer shell,
 - wherein the top handle is attached to a reinforcement patch,
 - wherein the reinforcement patch is secured to an upper surface of the lid assembly with an adhesive or welding,
 - wherein the reinforcement patch is positioned between the top handle and the reinforcement panel, and
 - wherein the reinforcement panel is configured to assist in preventing the lid assembly from bowing when the insulating device is carried in an upright position.
- 20. The insulating device of claim 19, wherein the insulating device is substantially in a shape of a cuboid.
- 21. The insulating device of claim 19 further comprising a base, wherein the base is more rigid than the outer shell, the base is more rigid than the inner liner, and wherein the base includes a molded logo or name on a bottom surface.
- 22. The insulating device of claim 19, wherein the top handle is stitched to the reinforcement patch with a thread, and wherein the thread does not extend into the insulating layer.

40

- 23. An insulating device comprising:
 - an outer shell;
 - an inner liner forming a storage compartment;
 - an insulating layer,
 - wherein the insulating layer provides insulation for the storage compartment, and
 - wherein the insulating layer is a foam layer positioned between the outer shell and the inner liner;
 - an opening configured to allow access to the storage compartment;
 - a closure,
 - wherein the closure is adapted to substantially close the opening to resist contents from exiting the opening;
 - at least two carry straps,
 - wherein a first carry strap and a second carry strap are positioned at an upper portion of the insulating device;
 - at least two side handles,
 - wherein the side handles are attached at the upper portion of the insulating device; and
 - a base,
 - wherein the base is more rigid than the outer shell, the base is more rigid than the inner liner, and the base is more rigid than the insulating layer,
 - wherein the base is compression molded,
 - wherein the base includes a logo or name on a bottom surface, and
 - wherein the base includes a support ridge.
- 24. The insulating device of claim 23 further comprising at least one shoulder strap, wherein the shoulder strap is configured to adjust to modify a shoulder strap length.
- 25. The insulating device of claim 23, wherein the insulating layer is attached to the inner liner or the outer shell.
- 26. The insulating device of claim 25, wherein the side handles are sewn to a reinforcement area, and wherein the reinforcement area is affixed to the upper portion of the insulating device.
- 27. The insulating device of claim 23, wherein at least one of the carry straps further includes at least one attachment point positioned at a bottom of the at least one of the carry straps.
- 28. The insulating device of claim 27, wherein the attachment point is constructed of nylon webbing.
- 29. The insulating device of claim 28, wherein the attachment point is configured to secure a bottle opener.
- 30. The insulating device of claim 28, wherein the attachment point is configured to secure a ring, wherein the ring is constructed of a metal, and wherein the ring is rectangular or square shaped.

* * * * *