



(12) **United States Design Patent**  
**Roy et al.**

(10) **Patent No.:** **US D791,023 S**  
(45) **Date of Patent:** **\*\* Jul. 4, 2017**

- (54) **TORQUE ARM**
- (71) Applicant: **Superpedestrian Inc.**, Cambridge, MA (US)
- (72) Inventors: **Robert Paul Roy**, Dracut, MA (US);  
**Marco Maria Pedrazzo**, Cuneo (IT);  
**Assaf Biderman**, Boston, MA (US);  
**Carlo Ratti**, London (GB)
- (73) Assignee: **Superpedestrian, Inc.**, Cambridge, MA (US)
- (\*\*) Term: **14 Years**

|              |         |                   |         |
|--------------|---------|-------------------|---------|
| D269,506 S   | 6/1983  | Suzuki et al.     |         |
| D269,603 S   | 7/1983  | Whitmarsh         |         |
| D281,062 S   | 10/1985 | Hess              |         |
| D312,998 S   | 12/1990 | Carlson           |         |
| D416,830 S * | 11/1999 | McKay .....       | D12/114 |
| D458,202 S   | 6/2002  | Passarotto        |         |
| D462,042 S   | 8/2002  | Bernardi          |         |
| D471,491 S * | 3/2003  | Grove .....       | D12/114 |
| D472,507 S   | 4/2003  | Passarotto        |         |
| D498,722 S   | 11/2004 | Smith et al.      |         |
| D502,431 S * | 3/2005  | Matthies .....    | D12/114 |
| 7,156,196 B2 | 1/2007  | Katsaros et al.   |         |
| D564,419 S * | 3/2008  | Clontz .....      | D12/114 |
| D579,844 S   | 11/2008 | Hed               |         |
| D596,547 S   | 7/2009  | Passarotto et al. |         |

- (21) Appl. No.: **29/509,919**
- (22) Filed: **Nov. 21, 2014**
- (51) **LOC (10) Cl.** ..... **12-11**
- (52) **U.S. Cl.**  
USPC ..... **D12/114**
- (58) **Field of Classification Search**  
USPC ..... D12/107, 110, 114, 117, 223; D8/349,  
D8/354, 363, 373, 382; 280/288.4;  
248/200, 300, 304, 317, 339, 503;  
D15/143; D16/132  
CPC ... B62H 1/00; B62H 1/02; B62H 1/04; B62M  
6/40; B62M 6/60; B62K 19/30; B62K  
19/40; B62K 25/02  
See application file for complete search history.

*Primary Examiner* — Darlington Ly  
(74) *Attorney, Agent, or Firm* — GTC Law Group PC & Affiliates

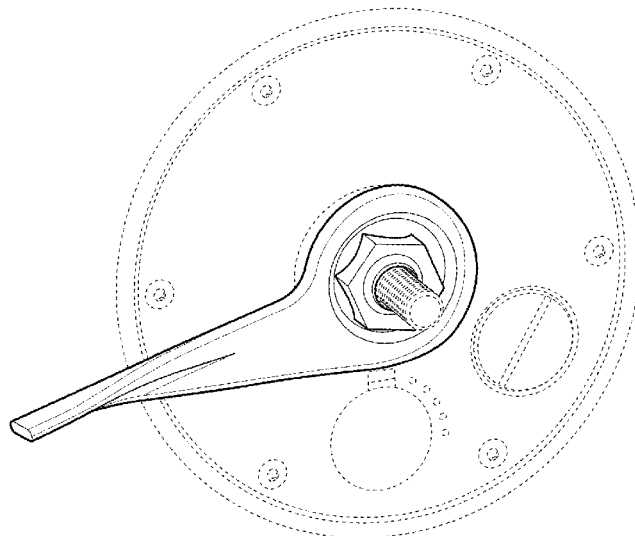
(57) **CLAIM**  
The ornamental design for a torque arm, as shown and described.

**DESCRIPTION**

FIG. 1 is a rear and left side perspective view of a torque arm depicted attached to an electrically powered wheel and frame of a vehicle;  
FIG. 2 is an enlarged front and left side perspective view of the torque arm in FIG. 1;  
FIG. 3 is an enlarged front and left side perspective view of the torque plate component of the torque arm;  
FIG. 4 is an enlarged perspective view of the contoured nut of the torque arm; and,  
FIG. 5 is an enlarged front and right side perspective view of the torque plate component of the torque arm.  
The broken lines showing portions of an electrically powered wheel and vehicle frame are provided for the purpose of illustrating environmental structure and forms no part of the claimed design.

- (56) **References Cited**  
U.S. PATENT DOCUMENTS  
D103,728 S 3/1937 Lejeune  
3,432,158 A \* 3/1969 Goodwin ..... B6G 17/025  
267/278  
D218,232 S 8/1970 Shimano et al.  
D218,964 S 10/1970 Shimano  
D232,630 S 9/1974 Siroonian et al.  
D248,747 S 8/1978 Hood  
D269,081 S 5/1983 Hayashi

**1 Claim, 3 Drawing Sheets**



(56)

**References Cited**

## U.S. PATENT DOCUMENTS

|              |      |         |                 |                        |
|--------------|------|---------|-----------------|------------------------|
| 7,673,946    | B1   | 3/2010  | Hed et al.      |                        |
| D613,206     | S *  | 4/2010  | Norman .....    | D12/114                |
| D625,333     | S    | 10/2010 | Tanaka et al.   |                        |
| D657,726     | S    | 4/2012  | Finnie          |                        |
| D685,686     | S *  | 7/2013  | Pirola .....    | D12/114                |
| 8,657,047    | B2   | 2/2014  | Urabe et al.    |                        |
| D721,315     | S    | 1/2015  | Delavy          |                        |
| D729,128     | S *  | 5/2015  | Forget .....    | D12/114                |
| 9,027,681    | B2 * | 5/2015  | Biderman .....  | B60B 1/003<br>180/220  |
| D750,999     | S    | 3/2016  | Zichner         |                        |
| D753,040     | S    | 4/2016  | Lisanti et al.  |                        |
| D764,365     | S    | 8/2016  | Hirai et al.    |                        |
| D766,801     | S    | 9/2016  | Lin et al.      |                        |
| 2012/0037442 | A1 * | 2/2012  | Radtke .....    | B60K 1/04<br>180/220   |
| 2013/0241175 | A1 * | 9/2013  | Talavasek ..... | B62M 6/40<br>280/288.4 |
| 2016/0075177 | A1   | 3/2016  | Biderman et al. |                        |
| 2016/0082772 | A1   | 3/2016  | Biderman et al. |                        |

\* cited by examiner

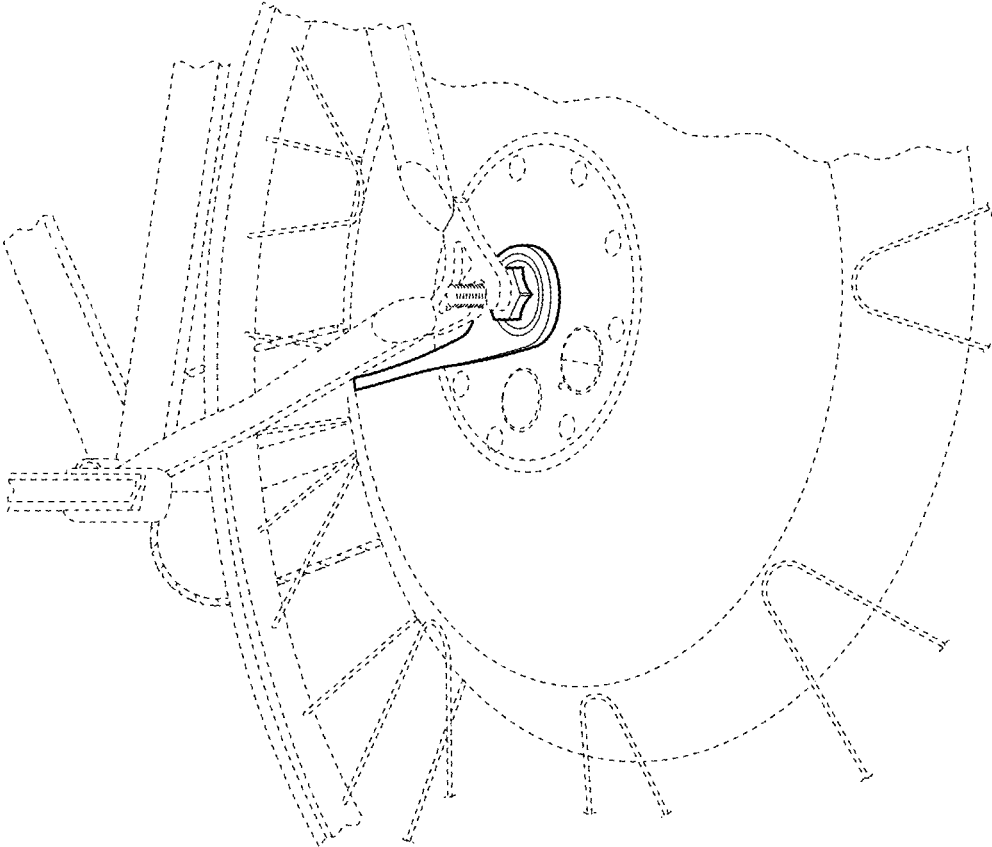
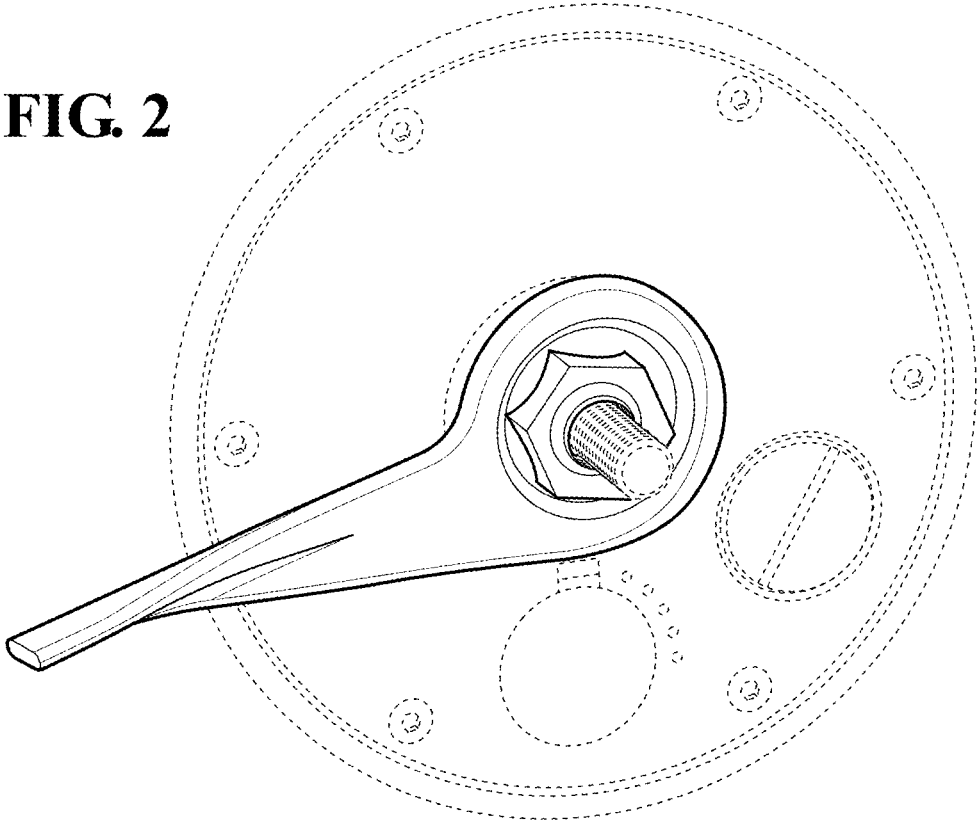
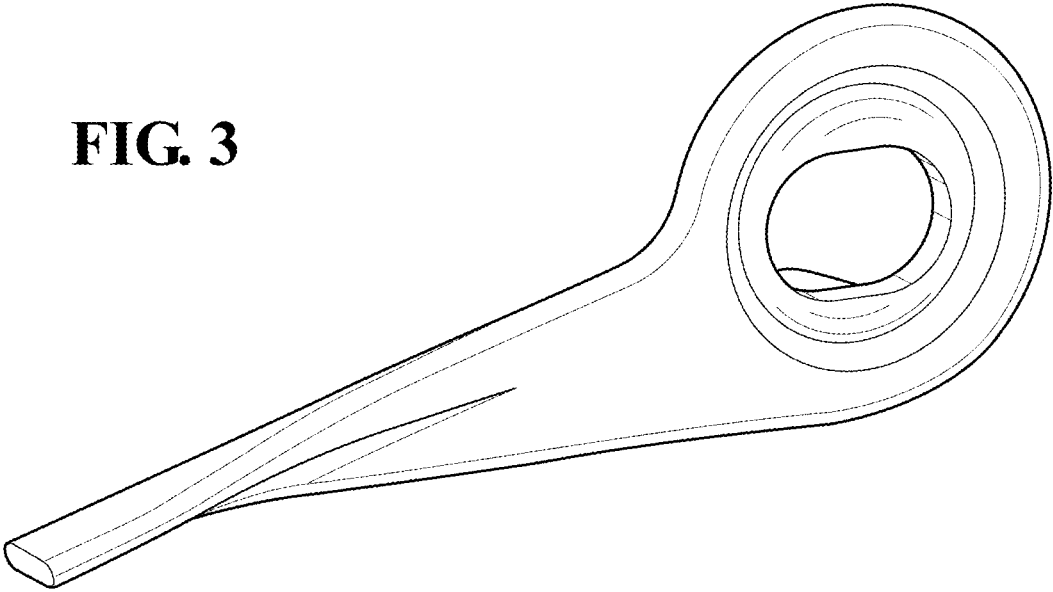


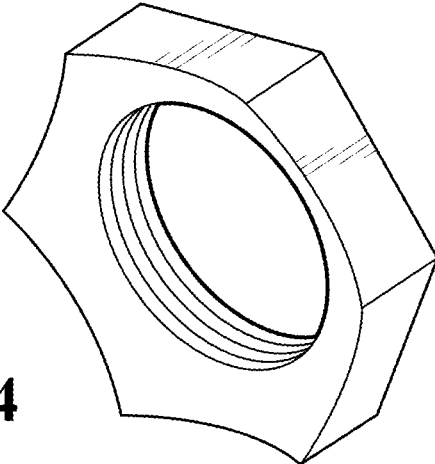
FIG. 1

**FIG. 2**

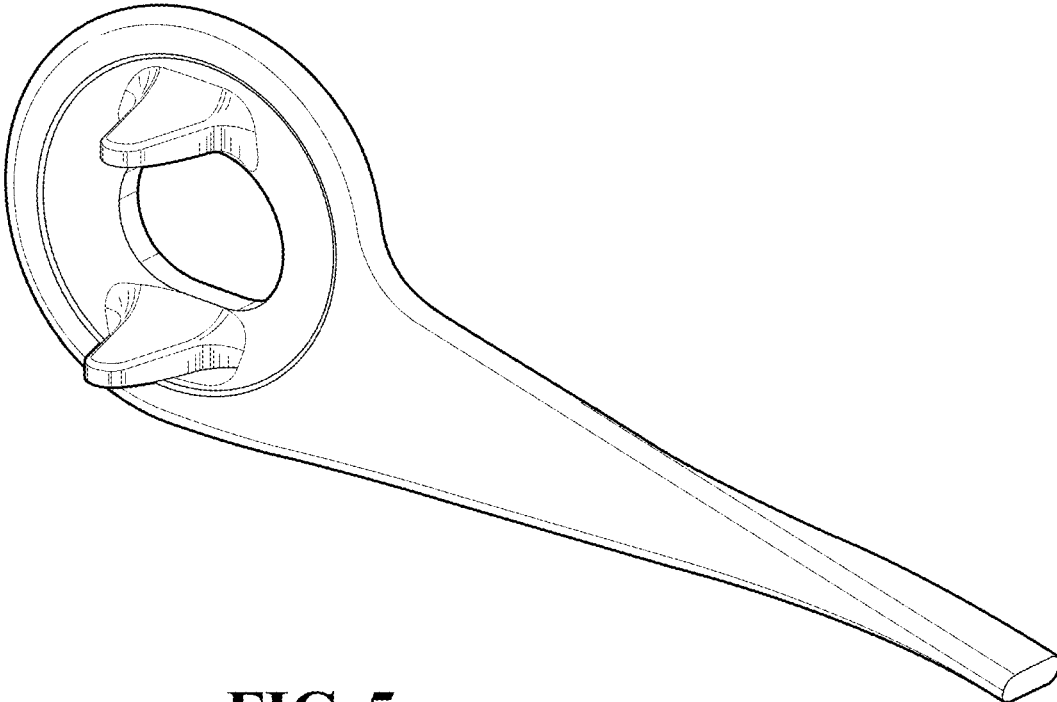


**FIG. 3**





**FIG. 4**



**FIG. 5**