



US00D489809S

(12) **United States Design Patent** (10) **Patent No.:** **US D489,809 S**
Gajewski (45) **Date of Patent:** **** May 11, 2004**

- (54) **CEILING FAN COMPONENT**
- (75) Inventor: **Mark Gajewski**, San Luis Obispo, CA (US)
- (73) Assignee: **Minka Lighting, Inc.**, Corona, CA (US)
- (**) Term: **14 Years**
- (21) Appl. No.: **29/162,419**
- (22) Filed: **Jun. 14, 2002**
- (51) **LOC (7) Cl.** **23-04**
- (52) **U.S. Cl.** **D23/411**
- (58) **Field of Search** D23/411, 377, D23/379, 385; 416/5; 392/364

U.S. patent application Ser. No. 29/162,417, Gajewski, filed Jun. 14, 2002.
 AireTek™ Advertisement, 1 page, after Apr. 2002.
 Preview page in Residential Lighting magazine, p. 102, Jun. 2002.
 Minka Lighting, Inc.; MinkaAire Two Thousand Two; Apr. 22, 2002; pp. 22, 23; Minka Lighting, Inc.; U.S.A.
Primary Examiner—Lisa Lichtenstein
 (74) *Attorney, Agent, or Firm*—Jenkins & Gilchrist, P.C.

(57) **CLAIM**

The ornamental design for a ceiling fan component, as shown and described.

DESCRIPTION

FIG. 1 is a top view of the ceiling fan component illustrating the environment of the component in accordance with my design;
 FIG. 2 is a bottom view of the ceiling fan component illustrating the environment of the component in accordance with my design;
 FIG. 3 is a side elevation view of the ceiling fan component illustrating the environment of the component in accordance with my design;
 FIG. 4 is a front elevation view of the ceiling fan component illustrating the environment of the component in accordance with my design;
 FIG. 5 is a rear elevation view of the ceiling fan component in accordance with my design taken along line 5—5 in FIG. 3.
 FIG. 6 is an enlarged top view of the ceiling fan component in accordance with my design;
 FIG. 7 is an enlarged bottom view of the ceiling fan component in accordance with my design; and,
 FIG. 8 is an enlarged side elevation view of the ceiling fan component in accordance with my design.
 The broken line showing of environmental structure in FIGS. 1—4 is for illustrative purposes only and forms no part of the claimed design.

- (56) **References Cited**
- U.S. PATENT DOCUMENTS**

455,660 A	7/1891	Cooper
532,789 A	1/1895	Ketcher
697,588 A	4/1902	Wood
776,026 A	11/1904	Jacobson
816,759 A	4/1906	Stowe
1,056,668 A	3/1913	Happich, Jr.
1,094,540 A	4/1914	Dilg
1,115,479 A	11/1914	Ayres et al.

(List continued on next page.)

- FOREIGN PATENT DOCUMENTS**

FR	600.812	2/1926
FR	985.034	7/1951

- OTHER PUBLICATIONS**
- U.S. patent application Ser. No. 29/162,389, Gajewski, filed Jun. 14, 2002.
- U.S. patent application Ser. No. 29/162,390, Gajewski, filed Jun. 14, 2002.
- U.S. patent application Ser. No. 10/172,189, Gajewski et al., filed Jun. 14, 2002.

1 Claim, 5 Drawing Sheets

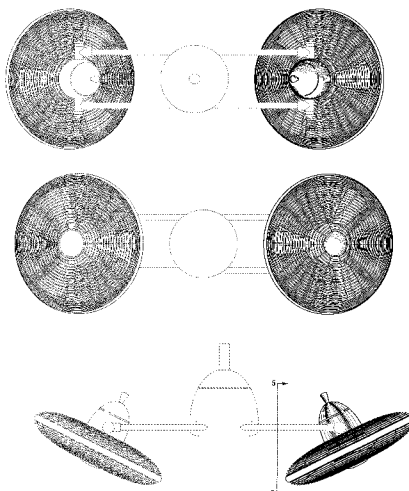

US D489,809 S

Page 2

U.S. PATENT DOCUMENTS					
			D313,467 S	1/1991	Frampton D23/379
1,224,218 A	5/1917	Scheibe	5,411,372 A	5/1995	Clark 416/110
1,226,076 A	5/1917	Jennings	5,443,625 A	8/1995	Schaffhausen 95/273
1,227,291 A	5/1917	Miller	5,668,920 A	9/1997	Pelonis 392/361
1,267,752 A	5/1918	Finch	D408,905 S	4/1999	Hadjikyriacou D23/378
1,270,832 A	7/1918	Jennings	5,951,253 A	9/1999	Gajewski 416/214 R
1,295,618 A	2/1919	Shaw	6,022,118 A	2/2000	Wu 362/35
1,332,875 A	3/1920	Ainsworth	6,022,189 A	2/2000	Yu 416/5
1,334,781 A	3/1920	Morse	6,074,182 A	6/2000	Matson 417/423.15
1,485,241 A	2/1924	Aronoff	6,146,191 A	11/2000	Kerr, Jr. et al. 439/537
1,517,623 A	12/1924	Francois	6,158,964 A	12/2000	Gajewski 416/244 R
1,826,458 A	10/1931	Cooper	6,171,060 B1	1/2001	Gajewski 416/244 R
1,903,615 A	4/1933	Towt	6,250,885 B1	6/2001	Gajewski 416/214 R
2,237,039 A	4/1941	Newnham 170/173	D451,996 S	12/2001	Liu D23/411
4,391,570 A	7/1983	Stutzman 417/353	6,354,801 B1	3/2002	Gajewski 416/5
4,560,321 A	12/1985	Kawai 416/23	6,357,714 B1	3/2002	Johnson 248/343
4,640,668 A	2/1987	Yang 417/354	D456,073 S	4/2002	Frampton D23/413
4,720,241 A	1/1988	Markwardt 416/5	6,364,617 B1	4/2002	Riske et al. 416/246
4,878,806 A	11/1989	Markwardt 416/5	6,364,638 B1	4/2002	Liu 417/423.15

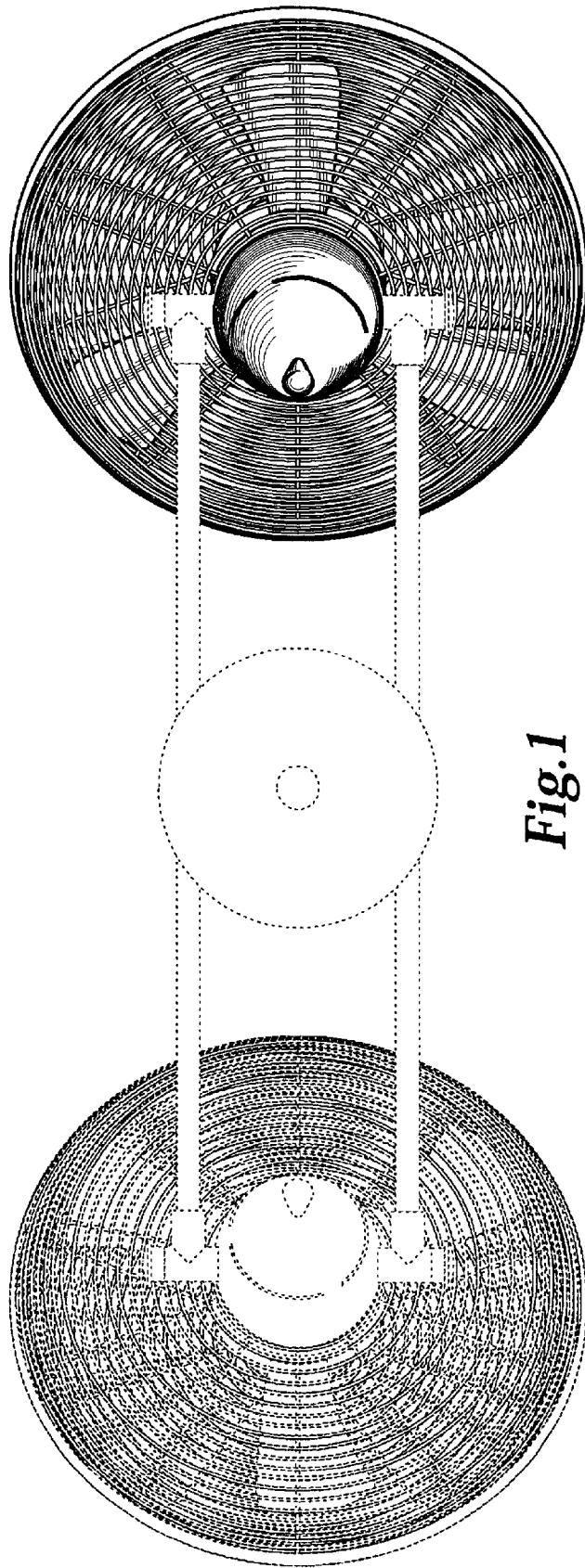

Fig. 1

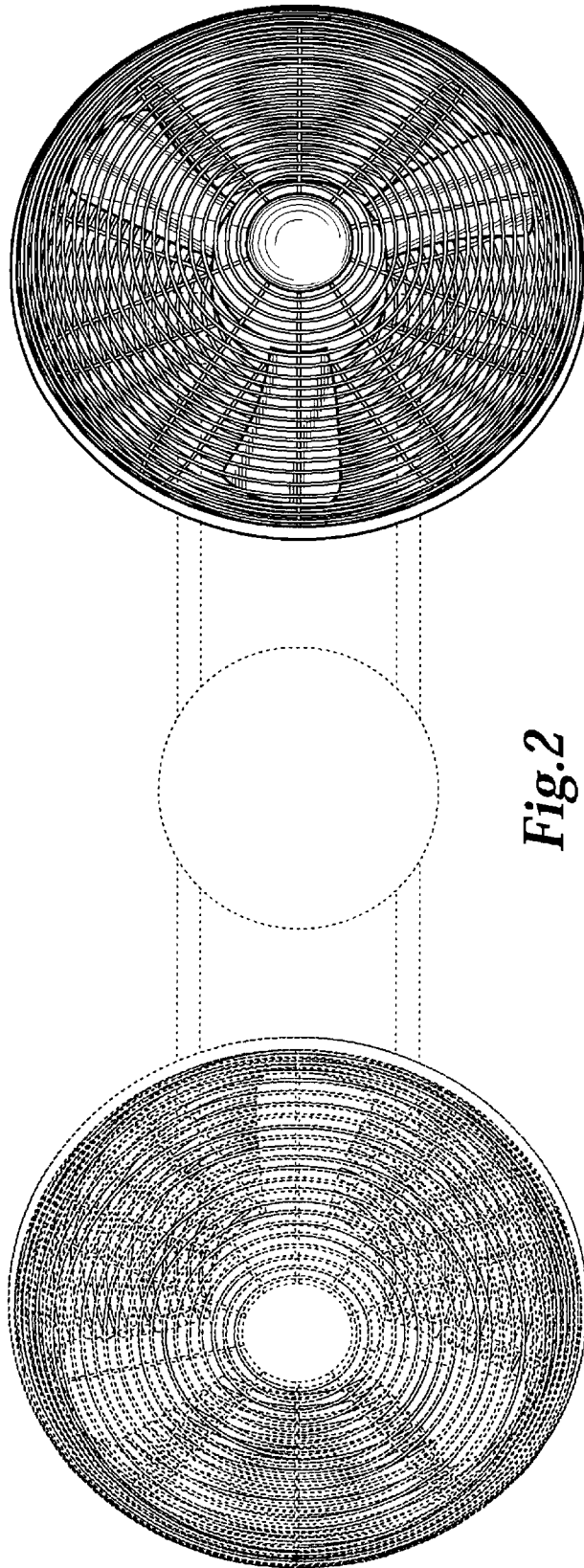

Fig. 2

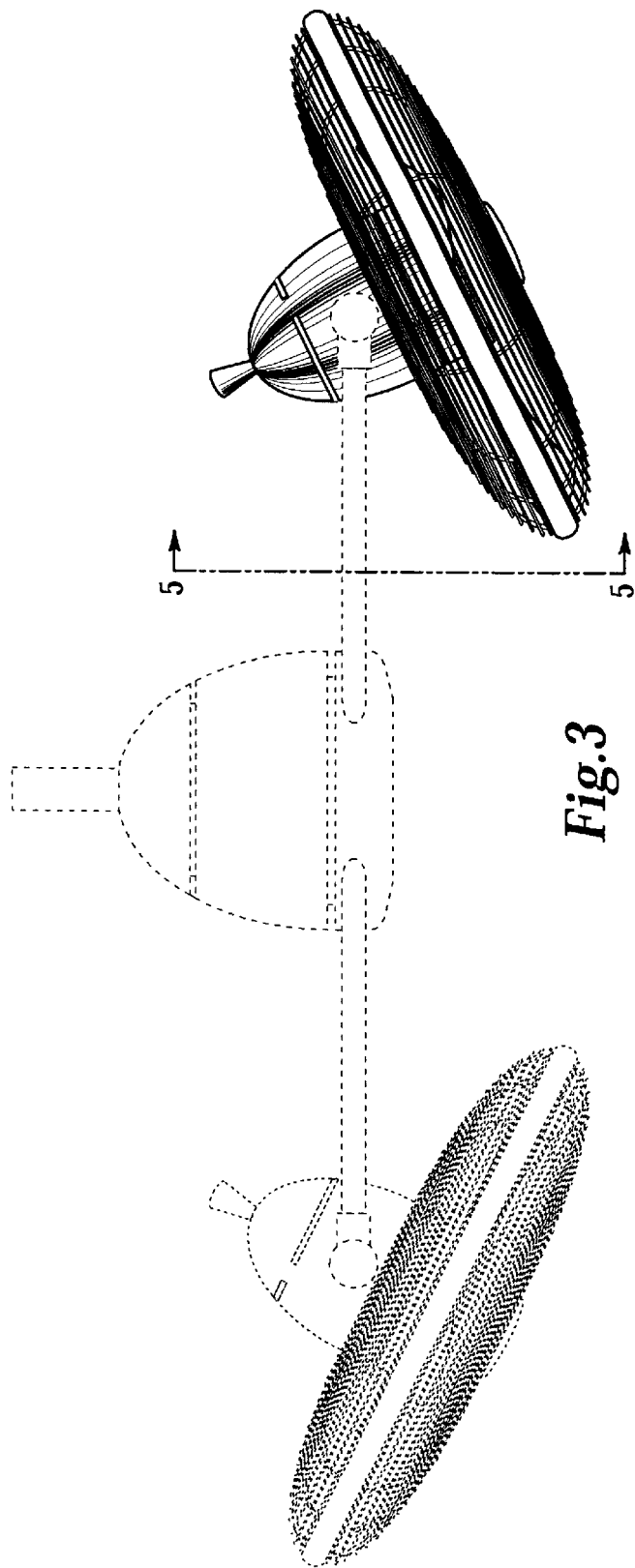

Fig. 3

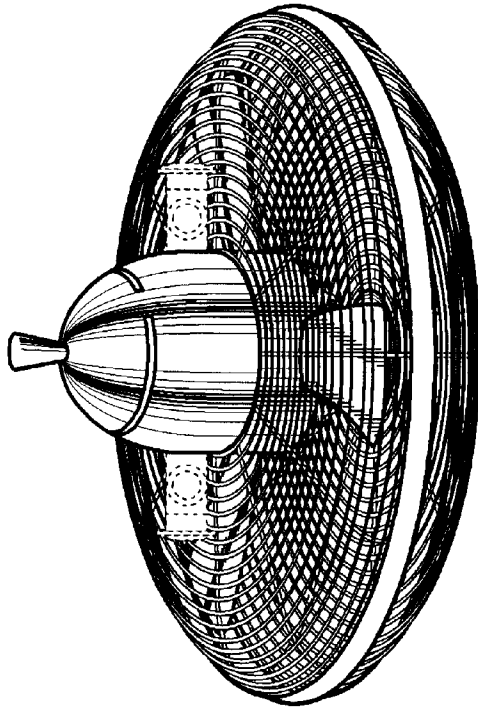

Fig. 5

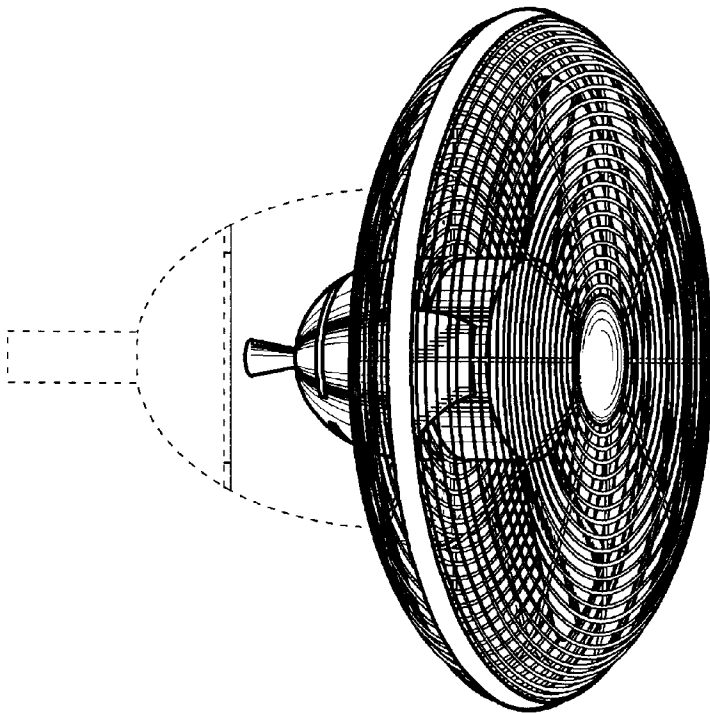

Fig. 4

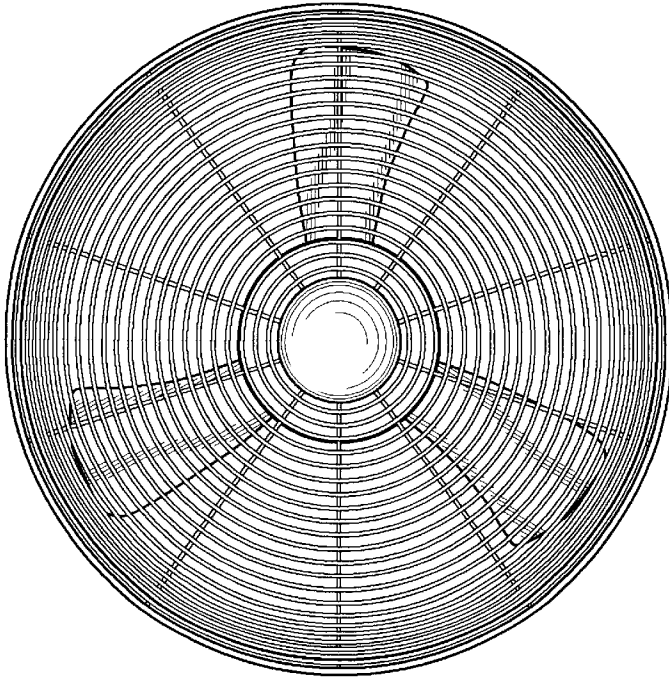

Fig.7

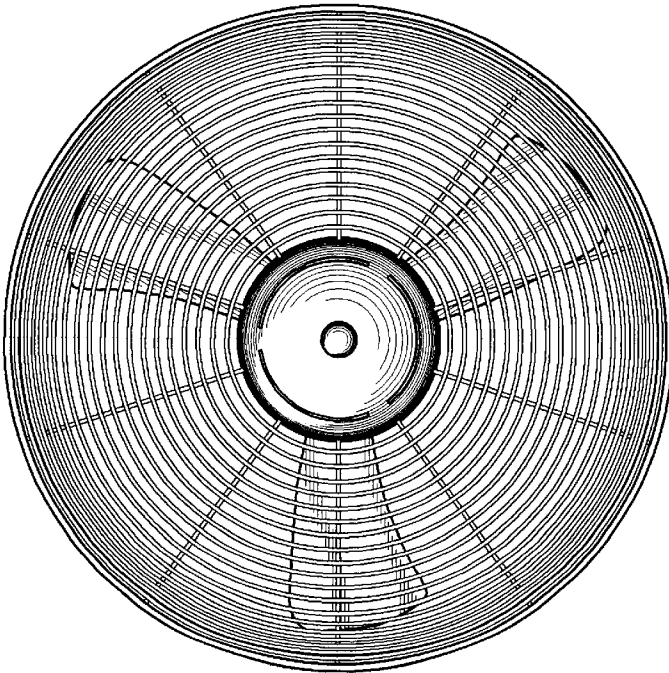

Fig.6

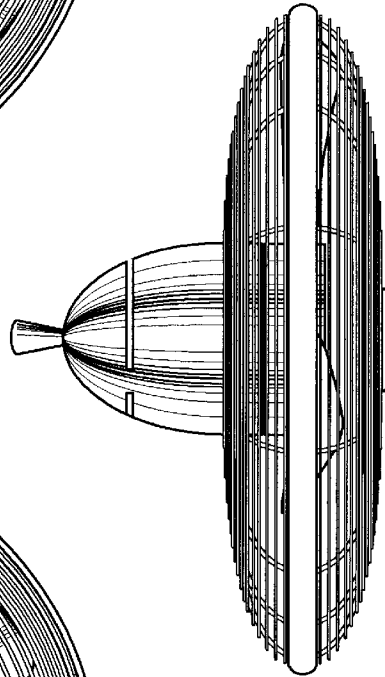

Fig.8