

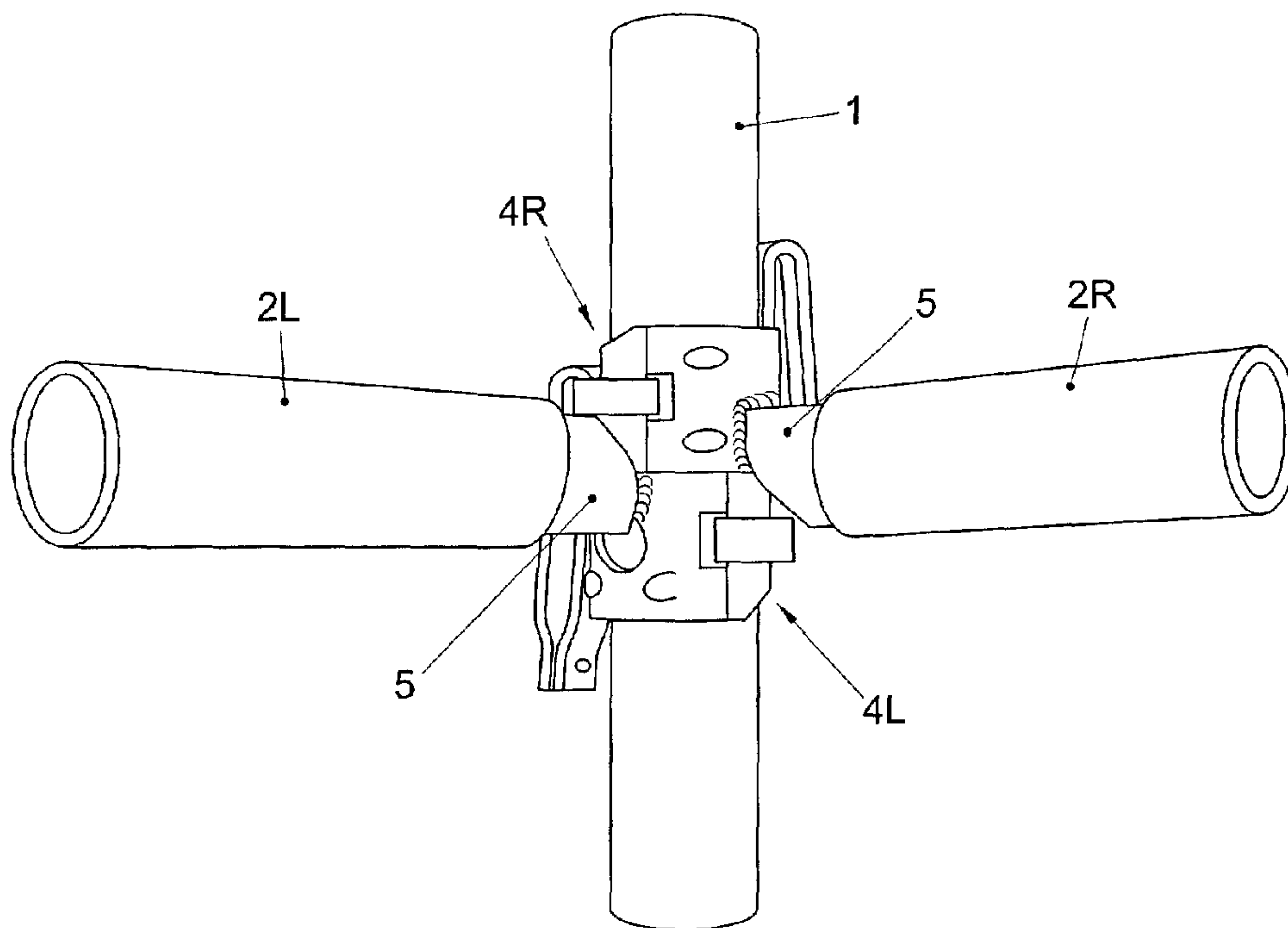

(86) Date de dépôt PCT/PCT Filing Date: 2002/08/29
 (87) Date publication PCT/PCT Publication Date: 2004/03/25
 (85) Entrée phase nationale/National Entry: 2005/02/25
 (86) N° demande PCT/PCT Application No.: NL 2002/000568
 (87) N° publication PCT/PCT Publication No.: 2004/025049

(51) Cl.Int.⁷/Int.Cl.⁷ E04G 7/22, F16B 7/04
 (71) Demandeur/Applicant:
 VERENIGDE BEDRIJVEN VAN THIEL (VAN THIEL
 UNITED) B.V., NL
 (72) Inventeur/Inventor:
 VAN DEN GOORBERGH, ANTON JACOBUS, NL
 (74) Agent: BORDEN LADNER GERVAIS LLP

(54) Titre : ECHAFAUDAGE, POUTRE POUR ECHAFAUDAGE ET PROCEDE DE CONSTRUCTION DE CELUI-CI
 (54) Title: SCAFFOLD, AND GIRDER INTENDED FOR SUCH A SCAFFOLD, AND METHOD FOR BUILDING A
 SCAFFOLD



(57) **Abrégé/Abstract:**

A scaffold, provided with uprights (1) and girders (2), wherein, at at least one end face (3) each girder (2) is integrally provided with a coupling means (4) for detachably coupling the girder (2) to a smooth part of an upright (1). The invention further provides a method for building a scaffold, wherein uprights (1) and girders (2) are coupled to each other, wherein at end faces (3), the girders (2) are integrally provided with coupling means (4) for coupling the girders (2) to the uprights (1), wherein a base for a scaffold floor is set up at a desired height via the following steps to be carried out in suitable order : a) uprights (1) are erected at desired positions; and b) at the desired height, girders (2) are coupled to smooth parts of the uprights (1) via the respective coupling means (4).

(12) INTERNATIONAL APPLICATION PUBLISHED UNDER THE PATENT COOPERATION TREATY (PCT)

(19) World Intellectual Property
Organization
International Bureau



(43) International Publication Date
25 March 2004 (25.03.2004)

PCT

(10) International Publication Number
WO 2004/025049 A1

- (51) International Patent Classification⁷: **E04G 7/22**, F16B 7/04
- (21) International Application Number: PCT/NL2002/000568
- (22) International Filing Date: 29 August 2002 (29.08.2002)
- (25) Filing Language: Dutch
- (26) Publication Language: English
- (71) Applicant (for all designated States except US): **VERENIGDE BEDRIJVEN VAN THIEL (VAN THIEL UNITED) B.V.** [NL/NL]; Bosscheweg 38-40, NL-5741 SX Beek en Donk (NL).
- (72) Inventor; and
- (75) Inventor/Applicant (for US only): **VAN DEN GOORBERGH, Anton, Jacobus** [NL/NL]; Mathildastraat 53, NL-5901 HC Oosterhout (NL).
- (74) Agent: **PRINS, A., W.**; Nieuwe Parklaan 97, NL-2587 BN Den Haag (NL).
- (81) Designated States (*national*): AE, AG, AL, AM, AT (utility model), AT, AU, AZ, BA, BB, BG, BR, BY, BZ, CA, CH, CN, CO, CR, CU, CZ (utility model), CZ, DE (utility model), DE, DK (utility model), DK, DM, DZ, EC, EE (utility model), EE, ES, FI (utility model), FI, GB, GD, GE, GH, GM, HR, HU, ID, IL, IN, IS, JP, KE, KG, KP, KR, KZ, LC, LK, LR, LS, LT, LU, LV, MA, MD, MG, MK, MN, MW, MX, MZ, NO, NZ, OM, PH, PL, PT, RO, RU, SD, SE, SG, SI, SK (utility model), SK, SL, TJ, TM, TN, TR, TT, TZ, UA, UG, US, UZ, VC, VN, YU, ZA, ZM, ZW.
- (84) Designated States (*regional*): ARIPO patent (GH, GM, KE, LS, MW, MZ, SD, SL, SZ, TZ, UG, ZM, ZW), Eurasian patent (AM, AZ, BY, KG, KZ, MD, RU, TJ, TM), European patent (AT, BE, BG, CH, CY, CZ, DE, DK, EE, ES, FI, FR, GB, GR, IE, IT, LU, MC, NL, PT, SE, SK, TR), OAPI patent (BF, BJ, CF, CG, CI, CM, GA, GN, GQ, GW, ML, MR, NE, SN, TD, TG).
- Published:**
— with international search report
- For two-letter codes and other abbreviations, refer to the "Guidance Notes on Codes and Abbreviations" appearing at the beginning of each regular issue of the PCT Gazette.

(54) Title: SCAFFOLD, AND GIRDER INTENDED FOR SUCH A SCAFFOLD, AND METHOD FOR BUILDING A SCAFFOLD

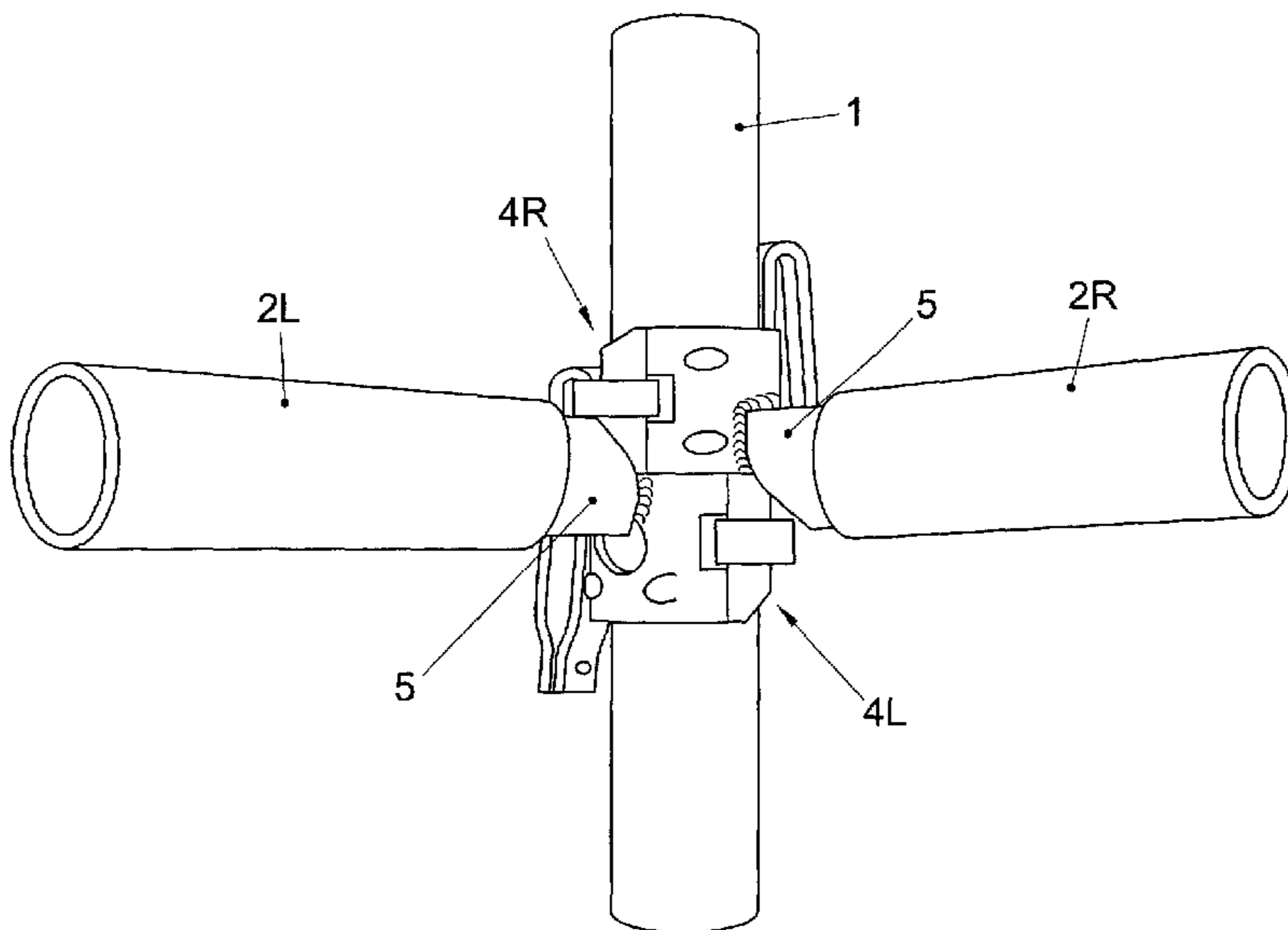

(57) Abstract: A scaffold, provided with uprights (1) and girders (2), wherein, at at least one end face (3) each girder (2) is integrally provided with a coupling means (4) for detachably coupling the girder (2) to a smooth part of an upright (1). The invention further provides a method for building a scaffold, wherein uprights (1) and girders (2) are coupled to each other, wherein at end faces (3), the girders (2) are integrally provided with coupling means (4) for coupling the girders (2) to the uprights (1), wherein a base for a scaffold floor is set up at a desired height via the following steps to be carried out in suitable order : a) uprights (1) are erected at desired positions; and b) at the desired height, girders (2) are coupled to smooth parts of the uprights (1) via the respective coupling means (4).

WO 2004/025049 A1

Title: Scaffold, and girder intended for such a scaffold, and method for building a scaffold.

The invention relates to a scaffold, provided with uprights and girders.

Such a scaffold is known from practice and is marketed by applicant. In the known scaffold system, tubular uprights and tubular girders are
5 detachably coupled to each other by means of scaffold tube clamps, for instance cross and/or pivot couplings. A disadvantage of this system is, that building the scaffold with such scaffold tube clamps is relatively cumbersome and hence time consuming. In particular a desired positioning of the different parts relative to each other can form a problem.

10 From practice, also a so-called system scaffold is known which can be built up and taken down relatively rapidly. Such a system scaffold is provided with uprights which are each provided, at fixed distances from each other, with integral connecting rings with eyelets. Generally, the mutual
15 distance mentioned between such connecting rosettes is 50 cm. At end faces, the girders of such a system scaffold are provided with hooks for hooking the girders to the eyelets of the connecting rings of the uprights. Through this design, the uprights and girders can relatively rapidly and firmly be detachably interconnected during the building of the scaffold.

A disadvantage of the system scaffold mentioned is that the girders
20 are only connectable to the uprights at fixed heights. While erecting and building the scaffold, this may lead to various problems. In the first place, generally, various objects are present on the ground where the scaffold is to be erected, for instance pipes, cables, pumps, vessels, tools, building materials and/or other objects. The height of such objects varies from building site to
25 building site. Therefore, each time, a lower scaffold floor is preferably positioned at a different height, depending on the height of objects present under it. However, in the system scaffold known from practice, this is not

possible as, each time, only a limited number of hooking positions are available, at heights of 50 cm, 100 cm, etc.

Moreover, the heights of the other scaffold floors are also fixed, for instance at 100 cm, 150 cm, 200 cm, etc. In some cases, this is unpractical, for instance when there is an obstacle present at such a height, such as a roof gutter, a casement or a different protrusion of, for instance, a nearby building.

The object of the present invention is to eliminate the drawbacks of the scaffold while maintaining its advantages. In particular, the invention contemplates a scaffold which can be erected and disassembled relatively easily and rapidly, while the girders can yet be coupled at any arbitrary position on the uprights.

To this end, according to the invention, the scaffold is characterized in that at at least one end face, each girder is integrally provided with a coupling means for detachably coupling the girder to a smooth part of an upright.

Thus, the scaffold can be built up in a simple manner, while the girders can rapidly be coupled to the uprights at a desired height. In this manner, a base for the scaffold floor can be set up at a desired height on a building site, in particular via the following steps, to be carried out in suitable order:

- a) uprights are erected at desired positions; and
- b) at the desired height, girders are coupled to smooth parts of the uprights via the respective coupling means. Then, the base can be provided with, for instance, scaffold floor parts to serve as a bottom scaffold level.

As the girders are connectable to the uprights at arbitrary positions, the girders can be positioned at the exact desired height. Moreover, the girders are already integrally provided with one or two coupling means, so that coupling to the upright can be carried out relatively rapidly. Building the scaffold can be further simplified by using girders of a limited number of fixed length dimension.

It is noted that the term "smooth" should be understood in a relatively broad sense. In particular, a smooth upright part should be understood to mean that that upright part is substantially not provided with certain protruding parts, such as, for instance, the integral connecting rosettes
5 mentioned.

Further elaborations of the invention are described in the subclaims. Presently, the invention will be further clarified with reference to two exemplary embodiments and the drawing. In the drawing:

Fig. 1 shows a top plan view of a first exemplary embodiment of the
10 invention;

Fig. 2 shows a side view of the girder of the top plan view represented in Fig. 1; and

Fig. 3 shows a front view, represented in perspective, of a second exemplary embodiment of the invention.

15 Fig. 1 shows a part of a scaffold which is provided with two uprights 1 between which a girder 2 has been provided. In the side view of the girder 2 represented in Fig. 2, the positions of the uprights 1 are drawn in interrupted lines. As shown in Figs. 1 and 2, the girder 2 is integrally provided at both end faces 3 with coupling means 4 for detachably coupling the girder 2 to smooth
20 parts of the uprights 1. Thus, the girder 2 is distinguished from girders of a system scaffold known from practice, which system girders are only provided at ends with hooks for hooking those girders to rosettes of uprights. Such system girders cannot be coupled to smooth tube parts.

As the girder 2 according to the invention can be coupled to smooth
25 parts of an upright tube 1, the girder 2 can be connected to the upright 1 at any desired height, at least if the upright 1 is of completely smooth design. In addition, the girder 2 provided by the invention can, for instance, be used in combination with the system scaffold upright mentioned. In that case, the girder 2 can be simply coupled by its coupling means 4 to the smooth upright
30 parts extending between the rosettes.

As shown in Figs. 1 and 2, each coupling means comprises a tube clamp 4 to be detachably connected to a smooth tube part. Via an integral connecting body 5, each tube clamp 4 is integrally connected to the girder 2. Each clamp 4 is built up analogously to half cross couplings for scaffold tubes known from practice and comprises a first clamp part 4a attached to the respective connecting body 5 to which clamp part a second clamp part 4b is hingedly coupled by means of a hinged joint connection 8. At a free end, each second clamp part 4b is provided with a movable wedge 7 for securing that clamp part 4b to a clamp lip 9 of the first clamp part 4a when the clamp parts 4a, 4b have been provided around an upright 1. Moreover, the two clamp parts 4a, 4b are moved towards each other by means of the wedge 7 such that those clamp parts 4a, 4b exert a desired clamping force on the upright 1.

As shown in the Figures, a cylindrical part of each connecting body 5 extends into the girder 2. The cylindrical part of each connecting body fits into the girder 2 with relatively little or no clearance. As a result, the connecting bodies 5 can be firmly attached to the girder 2, for instance by means of a glued and/or welded joint. Moreover, each connecting body 5 can be firmly connected to the girder 2 by means of thermal clamping. The girder 2 is then heated before the closely fitting connecting bodies 5 are slid into the girder 2. After cooling down and an attendant diameter reduction of the girder 2, the girder 2 can then very firmly clasp the connecting bodies 5. Preferably, each connecting body 5 is of substantially solid design, so that the body is relatively firm, rigid and strong. Moreover, each connecting body 5 is designed such that after assembly each end face 3 of the girder 2 is at a relatively small distance L from the outer side of the oppositely located upright 1. Preferably, this distance L is, for instance, smaller than approximately 5 cm.

As shown in Fig. 2, the tube clamp 4L of the girder 2 represented on the left hand side is located at an underside of a horizontal intersecting plane H, which plane H intersects the girder 2 along its central axis. Conversely, the tube clamp 4R represented on the right hand side is located on an opposite,

upper side of that intersecting plane H. This offers the important advantage that two of these girders 2 can extend at the same height when the girders are fitted to one upright 1. This is further described hereinbelow with reference to Fig. 3. Moreover, each connecting body 5 extends for a relatively large part at the same side of the intersecting plane H as the coupling means 4 connected to that connecting body 5. Further, the connecting bodies 5 of the girder 2 are each formed such that between each connecting body 5 and the oppositely located upright 1 sufficient space S exists for a part of a coupling means 4 of another girder 2 to be coupled at substantially the same height to that upright 1 (see Fig. 3). To that end, in the present exemplary embodiment, the upper side 6L of the left hand connecting body 5L runs diagonally to the tube clamp 4 connected thereto. The underside 6R of the right hand connecting body 5R also runs diagonally to the respective tube clamp 4.

Fig. 3 shows two girders 2 coupled by the respective integral tube clamps 4 to an upright 1. The two tube clamps 4 of these girders are clamped to the upright at abutting positions. The clamp 4L of the girder 2L represented on the left hand side in the Figure is located at an underside of a horizontal intersecting plane, which plane intersects the central axes of the two girders 2. The clamp 4R of the right hand girder 2R is located at the opposite side of that intersecting plane. Due to the positions of the clamps 4 with respect to the respective girders 2, both girders 2 extend at the same height. With a number of the girders 2 and uprights 1 represented, the system represented in Fig. 3 can be extended to a scaffold wherein, each time, a pair of girders 2 are coupled at the same height to an upright. This is advantageous, as, in this manner, the girders 2 can for instance provide one horizontal bearing surface for fitting floor parts (not shown) thereon at the same height. The floor parts can then extend in various directions from and/or over the girders 2. Moreover, as the distance L between the upright 1 and each girder 2 is relatively small, such floor parts can extend relatively close to the upright, so that no or only relatively narrow slits occur between the upright and the floor parts.

The connecting body 5 of each girder 2 allows the clamp 4 of the other girder 2 to be attachable to and detachable from the upright 1. This is achieved through the shape described of each connecting body, and in particular in that the connecting body 5 of each girder 2L, 2R, respectively, extends for a relatively large part at the same side of the intersecting plane as the tube clamp 4L, 4R, respectively, connected to that connecting body 5.

It is self-evident that the invention is not limited to the exemplary embodiments described. Various modifications are possible within the framework of the invention as set forth in the following subclaims.

10 For instance, the tube clamps 4 of the girder 2 can touch the horizontal intersecting plane H and/or be located at the respective side at a certain distance from that intersecting plane H.

Further, each coupling means 4 of the girder 2 can be designed in different manners, for instance as half cross coupling, half-pivot coupling or the like.

In addition, both coupling means 4 of each girder 2 can be located on opposite sides or, conversely, on the same side of the intersecting plane H mentioned, horizontal after assembly.

Further, the scaffold can be provided with various types of scaffold floors, for instance floors provided with floor parts which can be placed on girders and/or floor parts provided with hooks for hooking those floor parts to girders, for instance system decks.

In addition, uprights of the scaffold can for instance be connected to each other by end faces, for instance by means of "tube-lock"-couplings marketed by applicant.

Further, the scaffold can also be provided with different types of girders, such as girders which are not integrally provided with tube couplings, system girders comprising hooking means to be hooked to system uprights and/or other types of girders.

Claims

1. A scaffold, provided with uprights (1) and girders (2), characterized in that each girder (2) at at least one end face (3) is integrally provided with a coupling means (4) for detachably coupling the girder (2) to a smooth part of the upright (1).
- 5 2. A scaffold according to claim 1, characterized in that said coupling means of the girder (2) comprises a tube clamp (4) to be detachably connected to a smooth tube part.
3. A scaffold according to claim 1 or 2, characterized in that at least one coupling means (4) of the girder (2) is substantially located on one
10 respective side of a - at least after assembly in the scaffold - horizontal intersecting plane (H), which plane (H) intersects the girder (2).
4. A scaffold according to any one of the preceding claims, characterized in that each coupling means (4) is provided with an integral connecting body (5) which is integrally connected to the respective girder (2).
- 15 5. A scaffold according to claims 3 and 4, characterized in that a relatively large part of the connecting body (5) of each coupling means (4) is located at the same side of said intersecting plane (H) as the respective coupling means (4).
6. A scaffold according to at least claim 4, characterized in that each
20 connecting body (5) is of substantially solid design.
7. A scaffold according to at least claims 3 and 4, characterized in that each said connecting body (5) is designed for keeping a space (S) between the respective girder (2) and an oppositely located upright (1) clear, which space (S) is destined for a part of a coupling means (4) of a different girder (2) to be
25 coupled to that upright (1) at substantially the same height.

8. A scaffold according to at least claim 4, characterized in that each connecting body (5) extends at least partly in a respective end (3) of the respective girder (2).
9. A scaffold according to claim 8, characterized in that the connecting
5 body fits into the girder (2) with relatively little or no clearance.
10. A scaffold according to claim 4, characterized in that the connecting body (5) is designed such that the distance (L) between the end face (3) of the girder (2) and an outer side (6) of the upright (1), after assembly, is less than approximately 5 cm.
- 10 11. A scaffold according to any one of the preceding claims, characterized in that the girder (2) is integrally provided at both end faces (3) with coupling means (4) for coupling the girder (2) to uprights (1).
12. A scaffold according to claims 3 and 11, characterized in that the two
15 coupling means (4) of the girder (2) are located on opposite sides of said intersecting plane (H).
13. A scaffold according to any one of the preceding claims, characterized in that each coupling means (4) comprises a half cross-coupling.
14. A girder, evidently destined for a scaffold according to any one of the preceding claims.
- 20 15. A method for building a scaffold, wherein uprights (1) and girders (2) are coupled to each other, characterized in that at end faces (3), the girders (2) are integrally provided with coupling means (4) for coupling the girders (2) to the uprights (1), wherein a base for a scaffold floor is set up at a desired height via the following steps, to be carried out in suitable order:
- 25 a) uprights (1) are erected at desired positions; and
b) at the desired height, girders (2) are coupled to smooth parts of the uprights (1) via the respective coupling means (4).

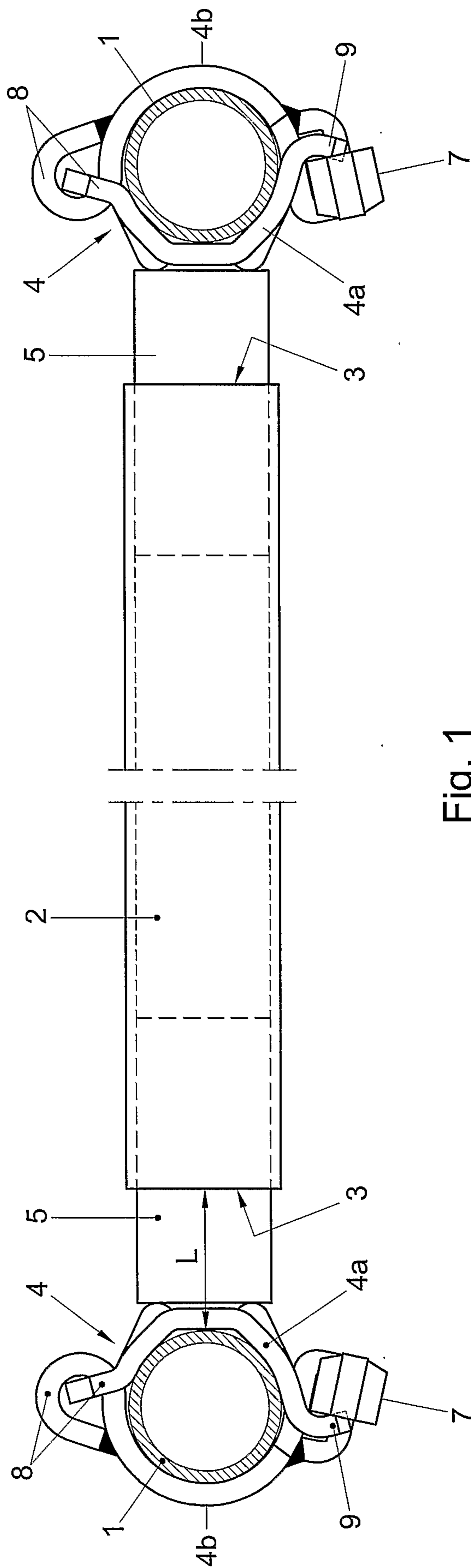

Fig. 1

2/3

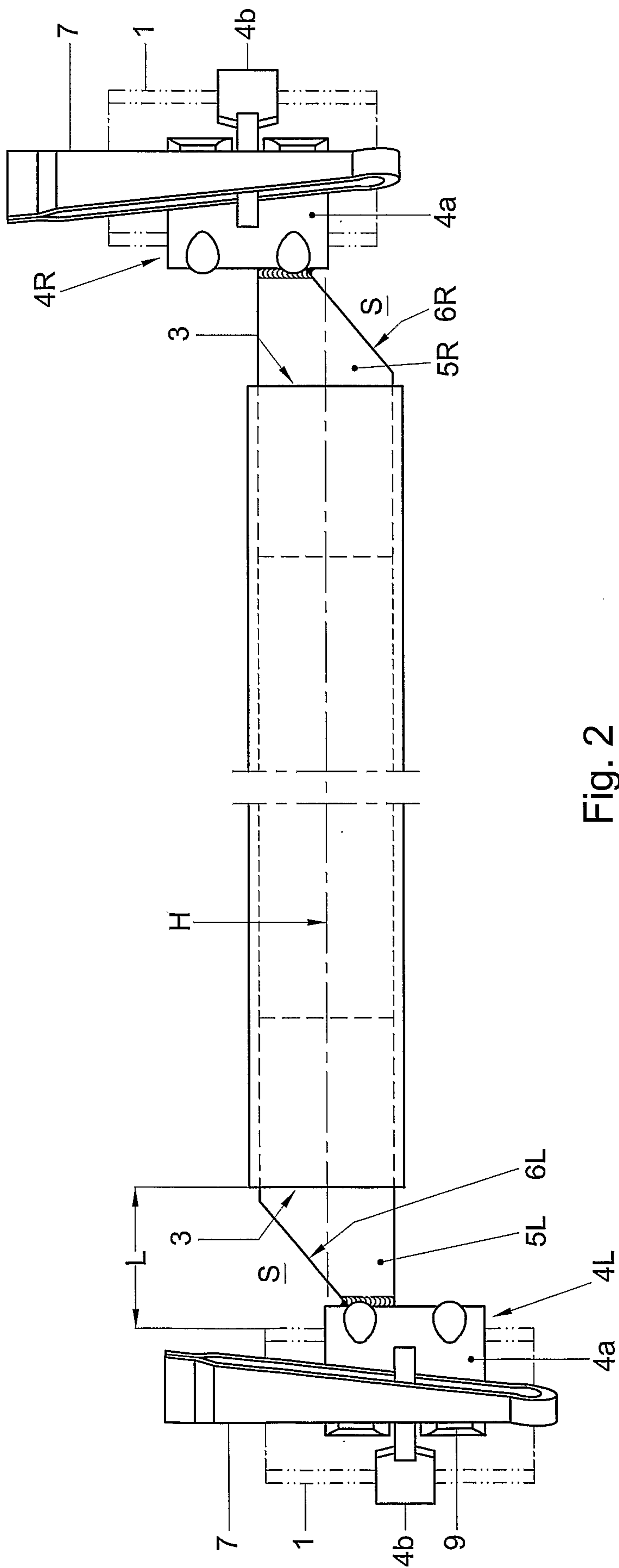

Fig. 2

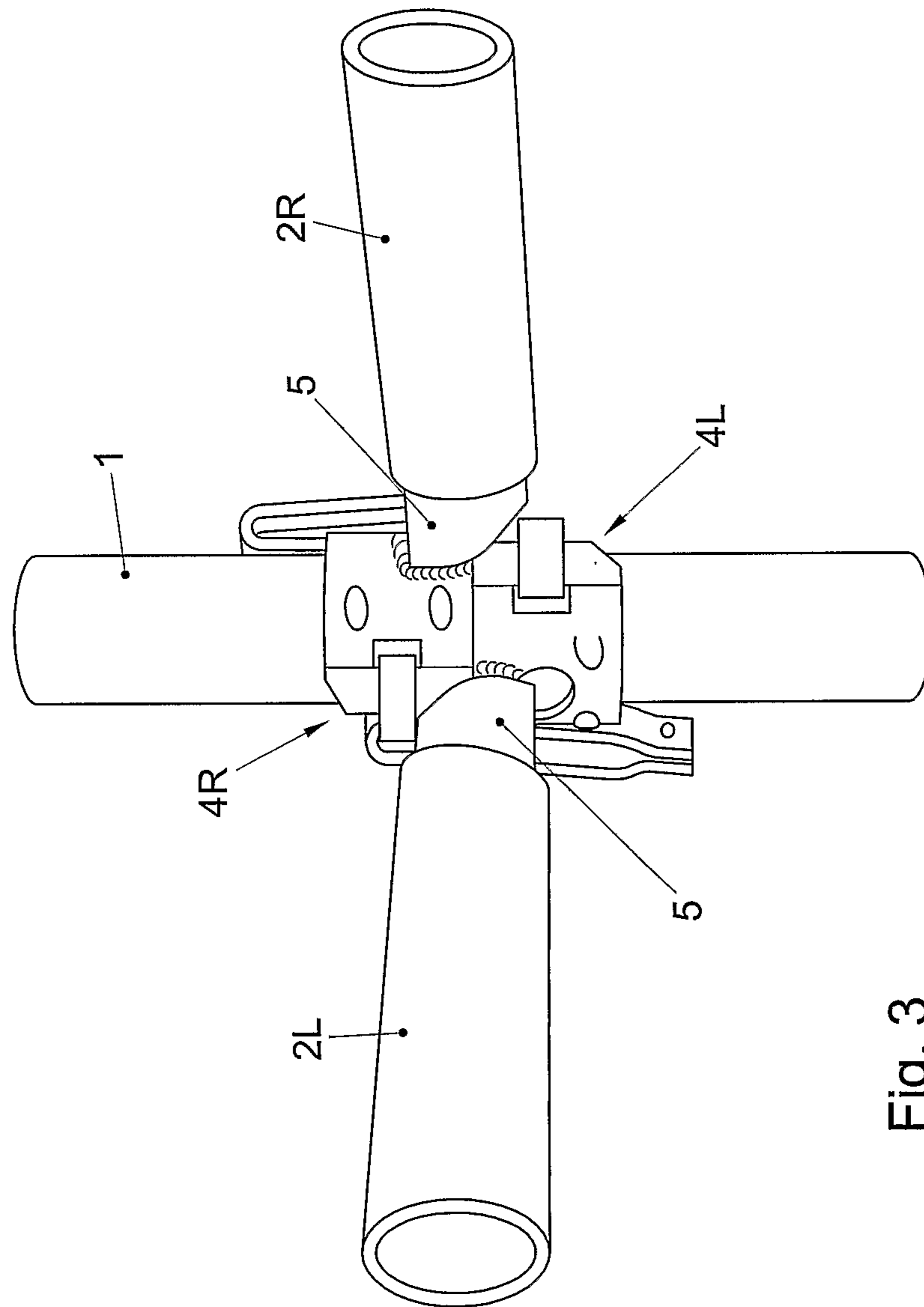

Fig. 3

