

(19) World Intellectual Property Organization
International Bureau



(43) International Publication Date
10 December 2009 (10.12.2009)

(10) International Publication Number
WO 2009/148787 A1

(51) International Patent Classification:

F16J 15/44 (2006.01) F01D 11/00 (2006.01)
F16J 15/447 (2006.01) F01D 11/02 (2006.01)

(21) International Application Number:

PCT/US2009/043943

(22) International Filing Date:

14 May 2009 (14.05.2009)

(25) Filing Language:

English

(26) Publication Language:

English

(30) Priority Data:

12/132,869 4 June 2008 (04.06.2008) US

(71) Applicant and

(72) Inventor: JUSTAK, John, F. [US/US]; 171 S. Sewall's Point, Stuart, FL 34996 (US).

(74) Agents: KAUTZ, Thomas, L. et al.; GrayRobinson, P.A., P.O. Box 2328, Fort Lauderdale, FL 33303-9998 (US).

(81) Designated States (unless otherwise indicated, for every kind of national protection available): AE, AG, AL, AM,

AO, AT, AU, AZ, BA, BB, BG, BH, BR, BW, BY, BZ, CA, CH, CN, CO, CR, CU, CZ, DE, DK, DM, DO, DZ, EC, EE, EG, ES, FI, GB, GD, GE, GH, GM, GT, HN, HR, HU, ID, IL, IN, IS, JP, KE, KG, KM, KN, KP, KR, KZ, LA, LC, LK, LR, LS, LT, LU, LY, MA, MD, ME, MG, MK, MN, MW, MX, MY, MZ, NA, NG, NI, NO, NZ, OM, PG, PH, PL, PT, RO, RS, RU, SC, SD, SE, SG, SK, SL, SM, ST, SV, SY, TJ, TM, TN, TR, TT, TZ, UA, UG, US, UZ, VC, VN, ZA, ZM, ZW.

(84) Designated States (unless otherwise indicated, for every kind of regional protection available): ARIPO (BW, GH, GM, KE, LS, MW, MZ, NA, SD, SL, SZ, TZ, UG, ZM, ZW), Eurasian (AM, AZ, BY, KG, KZ, MD, RU, TJ, TM), European (AT, BE, BG, CH, CY, CZ, DE, DK, EE, ES, FI, FR, GB, GR, HR, HU, IE, IS, IT, LT, LU, LV, MC, MK, MT, NL, NO, PL, PT, RO, SE, SI, SK, TR), OAPI (BF, BJ, CF, CG, CI, CM, GA, GN, GQ, GW, ML, MR, NE, SN, TD, TG).

Declarations under Rule 4.17:

- as to the identity of the inventor (Rule 4.17(i))
- of inventorship (Rule 4.17(iv))

[Continued on next page]

(54) Title: NON-CONTACT SEAL FOR A GAS TURBINE ENGINE

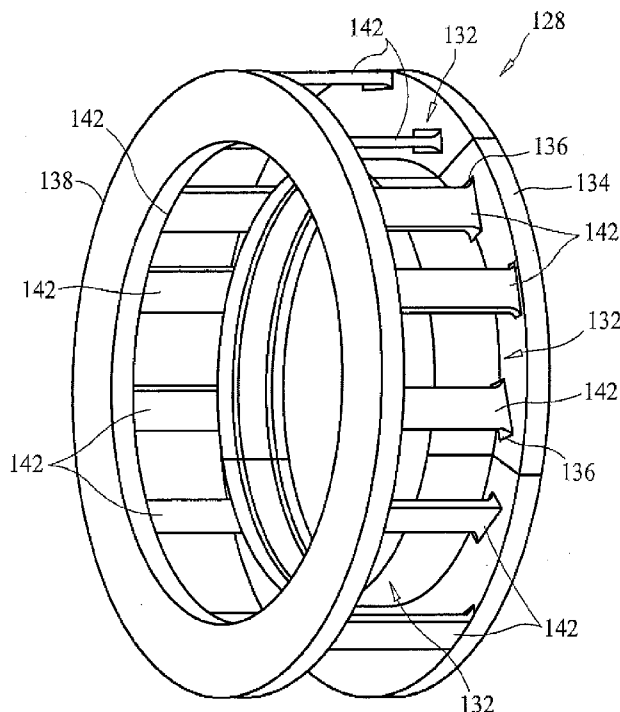

FIG. 12

(57) Abstract: A seal comprises the combination of a primary seal and a secondary seal each, of which acts on at least one shoe (134) that is installed with clearance relative to one of a rotor and a stator in a position to create a non-contact seal therewith. The at least one shoe is provided with a surface geometry and labyrinth-type teeth that influence the inertia of fluid flowing across the seal, and, hence, the velocity of the fluid and the pressure distribution across the seal, ultimately affecting the balance of forces applied to the seal.



WO 2009/148787 A1

Published:

— with international search report (Art. 21(3))

NON-CONTACT SEAL FOR A GAS TURBINE ENGINE

Related Applications

This application is a continuation-in-part application of U.S. Patent Application Serial No. 11/953,009 filed December 10, 2007, which is a continuation-in-part of U.S. Patent Application Serial No. 11/669,454 filed January 31, 2007, which is a continuation-in-part
5 application of U.S. Patent Application Serial No. 11/226,836 filed September 14, 2005 and now U.S. Patent No. 7,182,345, which is a continuation of U.S. Patent Application Serial No. 10/832,053 filed April 26, 2004, now abandoned, which claims the benefit of U.S. Provisional Application Serial No. 60/466,979 filed May 1, 2003
10 under 35 U.S.C. § 119(e) for all commonly disclosed subject matter. U.S. Provisional Application Serial No. 60/466,979 is expressly incorporated herein by reference in its entirety to form part of the present disclosure.

Field of the Invention

15 This invention relates to seals for sealing a circumferential gap between two machine components that are relatively rotatable with respect to each other, and, more particularly, to a non-contact seal especially intended for gas turbine engine applications having at least one shoe supported by a number of spring elements so that a first

-2-

surface of the at least one shoe extends along one of the machine components within design tolerances. The first surface of the at least one shoe may have a number of different geometries, and one or more cavities formed by radially inwardly extending tooth members, which collectively influences the velocity and pressure distribution of the fluid flowing across the seal thus allowing the seal clearance to be controlled in both directions, e.g. a larger or smaller radial clearance with respect to a machine component.

Background of the Invention

10 Turbomachinery, such as gas turbine engines employed in aircraft, currently is dependent on either labyrinth (see Figs. 1A-1E), brush (see Figs. 2A and 2B) or carbon seals for critical applications. Labyrinth seals provide adequate sealing but they are extremely dependent on maintaining radial tolerances at all points of engine operation. The radial clearance must take into account factors such as thermal expansion, shaft motion, tolerance stack-ups, rub tolerance, etc. Minimization of seal clearance is necessary to achieve maximum labyrinth seal effectiveness. In addition to increased leakage if clearances are not maintained, such as during a high-G maneuver, there is the potential for increases in engine vibration. Straight-thru labyrinth seals (Fig. 1A) are the most sensitive to clearance changes, with large clearances resulting in a carryover

15

20

-3-

effect. Stepped labyrinth seals (Figs. 1B and 1C) are very dependent on axial clearances, as well as radial clearances, which limits the number of teeth possible on each land. Pregrooved labyrinth seals (Fig. 1D) are dependent on both axial and radial clearances and must
5 have an axial clearance less than twice the radial clearance to provide better leakage performance than stepped seals.

Other problems associated with labyrinth seals arise from heat generation due to knife edge to seal land rub, debris from hardcoated knife edges or seal lands being carried through engine passages, and
10 excessive engine vibration. When seal teeth rub against seal lands, it is possible to generate large amounts of heat. This heat may result in reduced material strength and may even cause destruction of the seal if heat conducted to the rotor causes further interference. It is possible to reduce heat generation using abradable seal lands, but
15 they must not be used in situations where rub debris will be carried by leakage air directly into critical areas such as bearing compartments or carbon seal rubbing contacts. This also holds true for hardcoats applied to knife edges to increase rub capability. Other difficulties with hardcoated knife edges include low cycle fatigue life
20 debits, rub induced tooth-edge cracking, and the possibility of handling damage. Engine vibration is another factor to be considered when implementing labyrinth seals. As mentioned previously, this

-4-

vibration can be caused by improper maintenance of radial clearances. However, it can also be affected by the spacing of labyrinth seal teeth, which can produce harmonics and result in high vibratory stresses.

5 In comparison to labyrinth seals, brush seals can offer very low leakage rates. For example, flow past a single stage brush seal is approximately equal to a four knife edge labyrinth seal at the same clearance. Brush seals are also not as dependent on radial clearances as labyrinth seals. Leakage equivalent to approximately a 2 to 3 mil
10 gap is relatively constant over a large range of wire-rotor interferences. However, with current technology, all brush seals will eventually wear to line on line contact at the point of greatest initial interference. Great care must be taken to insure that the brush seal backing plate does not contact the rotor under any circumstances. It
15 is possible for severing of the rotor to occur from this type of contact. In addition, undue wire wear may result in flow increases up to 800% and factors such as changes in extreme interference, temperature and pressure loads, and rubbing speeds must be taken into account when determining seal life.

20 The design for common brush seals, as seen in Figs. 2A and 2B, is usually an assembly of densely packed flexible wires sandwiched between a front plate and a back plate. The free ends of the wires

-5-

protrude beyond the plates and contact a land or runner, with a small radial interference to form the seal. The wires are angled so that the free ends point in the same direction as the movement of the runner. Brush seals are sized to maintain a tight diametral fit throughout
5 their useful life and to accommodate the greatest combination of axial movement of the brush relative to the rotor.

Brush seals may be used in a wide variety of applications. Although brush seal leakage generally decreases with exposure to repeated pressure loading, incorporating brush seals where extreme
10 pressure loading occurs may cause a "blow over" condition resulting in permanent deformation of the seal wires. Brush seals have been used in sealing bearing compartments, however coke on the wires may result in accelerated wear and their leakage rate is higher than that of carbon seals.

15 One additional limitation of brush seals is that they are essentially uni-directional in operation, i.e., due to the angulation of the individual wires, such seals must be oriented in the direction of rotation of the moving element. Rotation of the moving element or rotor in the opposite direction, against the angulation of the wires,
20 can result in permanent damage and/or failure of the seal. In the particular application of the seals required in the engine of a V-22 Osprey aircraft, for example, it is noted that during the blade fold

-6-

wing stow operation, the engine rotates in reverse at very low rpm's. This is required to align rotor blades when stowing wings. This procedure is performed for creating a smaller aircraft footprint onboard an aircraft carrier. Reverse rotation of the engine would
5 damage or create failure of brush seals such as those depicted in Figs. 2A and 2B.

Carbon seals are generally used to provide sealing of oil compartments and to protect oil systems from hot air and contamination. Their low leakage rates in comparison to labyrinth or
10 brush seals are well-suited to this application but they are very sensitive to pressure balances and tolerance stack-ups. Pressure gradients at all operating conditions and especially at low power and idle conditions must be taken into account when considering the use of carbon seals. Carbon seals must be designed to have a sufficiently
15 thick seal plate and the axial stack load path must pass through the plate as straight as possible to prevent coning of the seal. Another consideration with carbon seals is the potential for seepage, weepage or trapped oil. Provisions must be made to eliminate these conditions which may result in oil fire, rotor vibration, and severe corrosion.

20 According to the Advanced Subsonic Technology Initiative as presented at the NASA Lewis Research Center Seals Workshop, development of advanced sealing techniques to replace the current

-7-

seal technologies described above will provide high returns on technology investments. These returns include reducing direct operating costs by up to 5%, reducing engine fuel burn up to 10%, reducing engine oxides of emission by over 50%, and reducing noise
5 by 7 dB. For example, spending only a fraction of the costs needed to redesign and re-qualify complete compressor or turbine components on advanced seal development can achieve comparable performance improvements. In fact, engine studies have shown that by applying advanced seals techniques to just a few locations can result in
10 reduction of 2.5% in SFC.

Summary of the Invention

This invention is directed to a non-contact seal for sealing the circumferential gap between a first machine component such as a stator and a second machine component such as a rotor which is
15 rotatable relative to the stator.

In one presently preferred embodiment, the seal comprises the combination of a primary seal and a secondary seal each of which acts on at least one shoe extending along one of the rotor and stator in a position to create a non-contact seal therewith. At least one spring
20 element is connected between one of the rotor and stator and the at least one shoe. The spring element may take the form of two or more radially spaced beams or bands, or a number of generally parallel

-8-

pins axially extending between a ring and the at least one shoe. The spring elements are flexible in the radial direction, but axially stiff so that they can function to assist in preventing roll over of the shoes with respect to the rotor or stator, thus maintaining an effective seal
5 under pressure load. The spring elements deflect and move with the at least one shoe in the radial direction in response to the application of aerodynamic forces applied to the at least one shoe to create a primary seal, within design tolerances, along the gap between the machine components.

10 The shoe(s) includes a first, sealing surface and a second surface opposite the first surface. The second surface is formed with a slot within which one end of a secondary seal may be disposed. It is contemplated that the slot may be positioned at the front (high pressure) or aft (low pressure) side of the shoe(s). The opposite end of
15 the secondary seal is connected to one of the first and second machine components. The secondary seal deflects and moves with the shoe(s) in response to the application of aerodynamic forces to the shoe(s), and applies a radial force acting in the direction of one of the first and second machine components to assist with the creation of a secondary
20 seal along the gap between the machine components.

In the presently preferred embodiment, the first, sealing surface of the shoe(s) may be formed with different geometric

features, and one or more cavities located between axially spaced labyrinth-type tooth elements, to affect the clearance between the sealing surface of the shoe(s) and the first or second machine component. As discussed below, this construction influences fluid velocity and pressure resulting from the application of aerodynamic forces to the seal, allowing for improved control of the clearance between the seal and the first or second machine component.

The seal of this invention can be utilized in all seal applications, including labyrinth, brush and carbon. The robust design eliminates the careful handling now required of carbon seals utilized in lube system compartments. This seal may allow the engine designer to utilize less parts in the assembly as this seal will permit "blind" assemblies to occur.

The following table provides a comparison of the seal of the subject invention with currently available technology.

Seal Type	Wear Rate	Leakage	Dependence on Clearances	Contamination Potential
Labyrinth Seals	High	Low	High	High
Brush Seals	Medium	Low	Medium	Medium
Carbon Seals	Medium	Very Low	High	Low
Hybrid Seal	Low	Low	Low	Low

Description of the Drawings

The structure, operation and advantages of this invention will become further apparent upon consideration of the following

-10-

description, taken in conjunction with the accompanying drawings,
wherein:

Figs. 1A-1E are schematic views of a number of prior art
labyrinth seals;

5 Figs. 2A and 2B depict views of a prior art brush seal;

Fig. 3 is an isometric view of the hybrid seal of this invention;

Fig. 4 is a partial, perspective view of the seal depicted in Fig.
3, illustrating a single shoe with the secondary seal removed;

Fig. 5 is a cross sectional view taken generally along line 5-5 of
10 Fig. 4;

Fig. 6 is a cross sectional view taken generally along line 6-6 of
Fig. 3, with a brush seal depicted as a secondary seal;

Fig. 7 is a view similar to Fig. 6 except with a secondary seal
comprising side-by-side plates;

15 Fig 8 is an enlarged, side view of a portion of one of the plates
shown in Fig. 7;

Fig. 9 is a force balance diagram of a shoe depicting the
aerodynamic forces, spring forces and secondary seal forces acting on
the shoe;

20 Figs. 10A-10G depict alternative embodiments of shoe(s)
having different geometric features;

-11-

Fig. 11 is a view similar to Fig. 7 except with the formation of axially spaced labyrinth-type tooth elements along the first surface of the at least one shoe;

Fig. 12 is a perspective view of an alternative embodiment of the seal of this invention employing axially spaced spring elements;

Fig. 13 is a perspective view of a portion of Fig. 12; and

Fig. 14 is a partial perspective view of a still further embodiment of the seal of this invention.

Detailed Description of the Preferred Embodiments

Referring initially to Figs. 3-6, the hybrid seal 10 of this invention is intended to create a seal of the circumferential gap 11 between two relatively rotating components, namely, a fixed stator 12 and a rotating rotor 14. The seal 10 includes at least one, but preferably a number of circumferentially spaced shoes 16 which are located in a non-contact position along the exterior surface of the rotor 14. Each shoe 16 is formed with a sealing surface 20 and a slot 22 extending radially inwardly toward the sealing surface 20. For purposes of the present discussion, the term "axial" or "axially spaced" refers to a direction along the longitudinal axis of the stator 12 and rotor 14, e.g. axis 18 shown in Figs. 3 and 10A – 10G, whereas "radial" refers to a direction perpendicular to the longitudinal axis 18.

-12-

Under some operating conditions, particularly at higher pressures, it is desirable to limit the extent of radial movement of the shoes 16 with respect to the rotor 14 to maintain tolerances, e.g. the spacing between the shoes 16 and the facing surface of the rotor 14.

5 The seal 10 preferably includes a number of circumferentially spaced spring elements 24, the details of one of which are best seen in Figs. 3 and 4. Each spring element 24 is formed with an inner band 26 and an outer band 28 radially outwardly spaced from the inner band 26. One end of each of the bands 26 and 28 is mounted to or integrally

10 formed with the stator 12 and the opposite end thereof is connected to a first stop 30. The first stop 30 includes a strip 32 which is connected to a shoe 16 (one of which is shown in Figs. 4 and 5), and has an arm 34 opposite the shoe 16 which may be received within a recess 36 formed in the stator 12. The recess 36 has a shoulder 38

15 positioned in alignment with the arm 34 of the first stop 30.

A second stop 40 is connected to or integrally formed with the strip 32, and, hence connects to the shoe 16. The second stop 40 is circumferentially spaced from the first stop 30 in a position near the point at which the inner and outer bands 26 and 28 connect to the

20 stator 12. The second stop 40 is formed with an arm 42 which may be received within a recess 44 in the stator 12. The recess 44 has a

-13-

shoulder 46 positioned in alignment with the arm 42 of second stop 40.

Particularly when the seal 10 of this invention is used in applications such as gas turbine engines, aerodynamic forces are developed which apply a fluid pressure to the shoe 16 causing it to move radially with respect to the rotor 14. The fluid velocity increases as the gap 11 between the shoe 16 and rotor 14 increases, thus reducing pressure in the gap 11 and drawing the shoe 16 radially inwardly toward the rotor 14. As the seal gap 11 closes, the velocity decreases and the pressure increases within the seal gap 11 thus forcing the shoe 16 radially outwardly from the rotor 14. The spring elements 24 deflect and move with the shoe 16 to create a primary seal of the circumferential gap 11 between the rotor 14 and stator 12 within predetermined design tolerances. The purpose of first and second stops 30 and 40 is to limit the extent of radially inward and outward movement of the shoe 16 with respect to the rotor 14 for safety and operational limitation. A gap is provided between the arm 34 of first stop 30 and the shoulder 38, and between the arm 42 of second stop 40 and shoulder 46, such that the shoe 16 can move radially inwardly relative to the rotor 14. Such inward motion is limited by engagement of the arms 34, 42 with shoulders 38 and 46, respectively, to prevent the shoe 16 from contacting the rotor

-14-

14 or exceeding design tolerances for the gap between the two. The arms 34 and 42 also contact the stator 12 in the event the shoe 16 moves radially outwardly relative to the rotor 14, to limit movement of the shoe 16 in that direction.

5 In the presently preferred embodiment, the seal 10 is also provided with a secondary seal which may take the form of a brush seal 45, as shown in Fig. 6, or a stack of at least two sealing elements oriented side-by-side and formed of thin sheets of metal or other suitable material as shown in Figs. 7 and 8. The brush seal 45 is
10 positioned so that one end of its bristles 47 extends into the slot 22 formed in the shoe 16. The bristles 47 deflect with the radial inward and outward movement of the shoe 16, in response to the application of fluid pressure as noted above, in such a way as to create a secondary seal of the gap 11 between the rotor 14 and stator 12.

15 Referring now to Figs. 7 and 8, the secondary seal of this embodiment may comprise a stack of at least two sealing elements 48 and 50. Each of the sealing elements 48 and 50 comprises an outer ring 52 formed with a number of circumferentially spaced openings 54, a spring member 56 mounted within each opening 54 and a
20 number of inner ring segments 58 each connected to at least one of the spring members 56. The spring member 56 is depicted in Fig. 8 as a series of connected loops, but it should be understood that spring

-15-

member 56 could take essentially any other form, including parallel bands as in the spring elements 24. The sealing elements 48 and 50 are oriented side-by-side and positioned so that the inner ring segments 58 extend into the slot 22 formed in the shoe 16. The
5 spring members 56 deflect with the radial inward and outward movement of the shoe 16, in response to the application of fluid pressure as noted above, in such a way as to create a secondary seal of the gap 11 between the rotor 14 and stator 12. As such, the sealing elements 58 and 50 assist the spring elements 24 in maintaining the
10 shoe 16 within design clearances relative to the rotor 14.

In the presently preferred embodiment, the spring elements 48 and 50 are formed of sheet metal or other suitable flexible, heat-resistant material. The sealing elements 48 and 50 may be affixed to one another, such as by welding, a mechanical connection or the like,
15 or they may merely be placed side-by-side within the slot 22 with no connection between them. In order to prevent fluid from passing through the openings 54 in the outer ring 52 of each sealing element 48 and 50, adjacent sealing elements are arranged so that the outer ring 52 of one sealing element 48 covers the openings 54 in the
20 adjacent sealing element 50. Although not required, a front plate 60 may be positioned between the spring element 24 and the sealing element 48, and a back plate 62 may be located adjacent to the

-16-

sealing element 50 for the purpose of assisting in supporting the sealing elements 48, 50 in position within the shoe 16.

In applications such as gas turbine engines, the seal 10 of this invention is subjected to aerodynamic forces as a result of the passage
5 of air along the surface of the shoes 16 and the rotor 14. The operation of seal 10 is dependent, in part, on the affect of these aerodynamic forces tending to lift the shoes 16 radially outwardly relative to the surface of rotor 14, and the counteracting forces imposed by the spring elements 24 and the secondary seals e.g. brush
10 seal 45 or the stacked seal formed by plates 48, 50 which tend to urge the shoes 16 in a direction toward the rotor 14. These forces acting on the shoe 16 are schematically depicted with arrows in Fig. 9. There must be a balance of forces acting on the seal 10 to ensure that nominal clearance is maintained.

15 Local pressures acting on the seal 10, induced by the pressure differential across the seal 10, have considerable impact on the force balance of seal 10. As noted above, when the seal gap 11 increases the fluid velocity increases and the pressure decreases along such gap 11 thus drawing the shoe 16 toward the rotor 14. As the seal gap 11
20 closes, creating a choked flow condition, the velocity of the fluid flowing through such gap 11 decreases thus increasing the pressure and forcing the shoes 16 away from the rotor 14. It has been found

-17-

that at least two design features formed on the surface of the shoes 16 facing the rotor 14 influence the velocity of the fluid and pressure distribution across the seal. One design feature comprises the geometric surface configuration of each shoe 16 immediately
5 upstream and downstream from a sealing area of such shoe 16, as discussed below in connection with a description of Figs. 10A to 10G. The second design feature comprises the provision of two or more labyrinth-type tooth elements that form cavities along the surface of the shoes 16 that faces the rotor 14, as described in connection with a
10 discussion of Figs. 11 to 14. These two design features collectively enhance control of the radial clearance between the shoes 16 and rotor 14, thus improving the performance of the seal 10 herein.

With reference initially to Figs. 10A-10G, a number of preferred geometries of the shoes 16 are illustrated. For ease of
15 illustration, only a portion of one shoe 16 is depicted in Figs. 10A-10G, and it should be understood that the gap or radial clearance between the shoe 16 and rotor 14 is exaggerated for purposes of illustration. Generally, each of the shoes 16 shown in Fig. 10A-10G include a radially inwardly extending flow contraction area 70, and
20 then variations of converging surfaces, diverging surfaces and other surfaces, as described individually below. For purposes of discussion of Figs. 10A-10D, the terms "longitudinal direction" and "axial

-18-

direction" refer to a direction along the longitudinal axis 18 of the rotor 14.

Referring to Fig. 10D, the shoe 16 has a first area 72 of substantially constant radial dimension upstream from the flow contraction area 70, and a second area 74 of substantially constant radial dimension downstream or aft of the step 70. The radial spacing of the second area 74, relative to the rotor 14, is less than that of the first area 72. A converging area 76 extends aft from the second area 74, and connects to a diverging area 78. A sealing area or edge 80 is formed at the juncture of the converging and diverging areas 76, 78. In the embodiment of Fig. 10A, the length of the converging area 76, measured in a longitudinal direction along axis 18, is less than the length of the diverging area 78.

The shoe 16 illustrated in the embodiment of Fig. 10B has the same flow contracting area 70, and first and second areas 72, 74, as Fig. 10A. A converging area 82 extends from the second area 74 and joins to a diverging area 86 along an edge 84 forming a sealing area of the shoe 16 in this embodiment. As seen in Fig. 10B, the length of converging area 82, measured along the longitudinal axis 18 of rotor 14, is greater than the length of the diverging area 86.

Referring to Fig. 10C, a shoe 16 is illustrated having the same construction as Fig. 10B, except that instead of a diverging area

-19-

connected to the converging area 86, a third area 88 of substantially constant radial spacing extends from the converging area 86. The radial spacing between the third area 88 and rotor 14 is less than that of the second area 74, which, in turn, is less than that of the first area 72. The third area 88 forms the sealing area of this version of the shoe 16.

The converging and diverging areas along the surface of the shoe 16 are eliminated in the embodiment of this invention depicted in Fig. 10D. The same first and second areas 72 and 74 connected to step 70 are employed, as described above, but then a second flow contraction area 90 connects the second area 74 to an elongated area 91 having a substantially constant radial spacing from the rotor 14. The radial spacing between the elongated area 91 and rotor 14 is less than that of the second area 74, which, in turn, is less than that of the first area 72. In the embodiment shown in Fig. 10D, the elongated area 91 forms the sealing area of shoe 16.

The shoe 16 of Fig. 10E is similar to that shown in Fig. 10A, except a converging area 92 extending from the second area 74, and a diverging area 94 connected at an edge 96 to the converging area 92, have substantially the same length as measured along the longitudinal axis 18. The edge 96 forms the sealing area of the shoe 16 illustrated in Fig. 10E.

-20-

In the embodiment of the shoe 16 illustrated in Fig. 10F, essentially the same construction as that depicted in Fig. 10C is provided except the third area 88 is eliminated and a converging area 98 extends from the second area 74 to the end of the shoe 16. The sealing area of shoe 16 depicted in Fig. 10F is located at the end edge 99 where the converging area 98 terminates. The same reference numbers used in Fig. 10C are employed in Fig. 10F to indicate common structure.

The shoe 16 of Fig. 10G is similar to that of Fig. 10D, except the elongated area 91 in Fig. 10D is eliminated and replaced with a diverging area 100. The diverging area 100 extends from the second flow contraction area 90 to the end edge of the shoe 16. A sealing area of the shoe 16 is formed at the juncture 101 of the flow contraction area 90 and diverging area 100. All other structure of the shoe 16 shown in Fig. 10G that is common to that of Fig. 10D is given the same reference numbers.

Referring now to Figs. 11-14, alternative embodiments of the seal of this invention are shown. The seals depicted in Figs. 11-14 share the common feature of the addition of labyrinth-type tooth elements to the surface of shoes 16 that faces the rotor 14, but the spring arrangement for supporting shoes 16 is different in the embodiments of Figs. 12-14 than that described above and is intended

for higher pressure applications. Fig. 11 is discussed first, followed by a description of the embodiments of Figs. 12-14.

The embodiment of the seal 10 depicted in Fig. 11 is similar to that described above in connection with a discussion of Figs. 3-8, and particularly Figs 7 and 8, except for the addition of two labyrinth-type tooth elements including a forward tooth element 110 and an aft tooth element 112 that is axially spaced (along the longitudinal axis 18) from the forward tooth element 110. The same reference numbers shown in Fig. 7 are used to identify like structures in Fig. 11. Each of the tooth elements 110 and 112 extends from the surface of the shoe 16 that faces the rotor 14 and has a tip 114 and 116, respectively, located within a predetermined design tolerance from the rotor 14. The tooth elements 110 and 112 decrease in thickness from their point of connection at the shoe 16 to the tips 114, 116, and are angled in a forward direction, i.e. in a direction opposing the aerodynamic forces applied to the shoe 16. Preferably, the forward tooth element 110 is somewhat shorter than the aft tooth element 112 to resist clogging of the gap between the tip 114 of the tooth element 110 and the rotor 14 in the event debris should become entrained in the flow of fluid toward the shoe 16.

A first cavity 118 is formed between the aft tooth element 112 and the flow contraction area 120 of shoe 16, and a second cavity 122

-22-

is formed between the forward and aft tooth elements 110, 112. While not wishing to be bound by any particular theory of operation of the seal 10 of Fig. 11, it is believed that the flow of fluid passing between the shoe 16 and rotor 14 swirls within the cavities 118 and 5 122 causing a reduction in the fluid pressure in that area. In response to such pressure reduction, the shoe 16 moves toward the rotor 14 creating an improved seal. The nominal clearance between the sealing area 124 of the shoe 16 depicted in Fig. 11 and the rotor 14 may be 0.001 inches, for example, but the addition of the cavities 10 118 and 122 causes the actual clearance during operation of the seal 10 to be less than 0.001 inches.

Despite the formation of the forward tooth element 110 somewhat shorter than the aft tooth element 112, as discussed above, it is nevertheless possible that the area between the tips 114, 116 15 thereof and the rotor 14 could become clogged with debris. This would result in a pressure drop in the region upstream from the sealing area 124 of the shoe 16 and could cause the shoe 16 to contact the rotor 14. To prevent this from occurring, an orifice or bleed hole 126 may be formed in the shoe 16 extending from the surface opposite 20 the rotor 14 into the first cavity 118, and/or the second cavity 122 may be formed with a bleed hole 127. Alternatively, or in addition to the bleed hole 126 and 127, a notch may be formed in the forward

-23-

tooth element 110 and/or the aft tooth element 112, such as shown in the embodiment of Fig. 14 discussed below. The bleed hole(s) 126, 127, and/or notch(es), act to prevent a sudden drop in pressure within the cavities 118 and 122 thus assisting in avoiding contact between
5 the shoe 16 and the rotor 14.

Referring now to Figs. 12-14, alternative embodiments of a seal 128 and a seal 130 are illustrated which are particularly intended for higher pressure applications than the seal of Figs. 3-11. The seal 128 depicted in Figs. 12 and 13 comprises at least one shoe 132 having a
10 first surface 134 and a second surface 136 radially spaced from the first surface 134. A number of shoes 132 are depicted in Fig. 12 for purposes of illustration. The first surface 134 of each shoe 132 may have one of the surface geometries shown in Figs. 10A to 10G, and it may further include labyrinth-type tooth elements 110 and 112 such
15 as depicted in Fig. 11. The structure and operation of such surface geometries, and the tooth elements 110, 112, is the same as that described above in connection with a discussion of Figs. 10A to 11, and the same reference numbers are therefore used in Figs. 12 and 13 to denote like structure. Additionally, the second surface 136 of the
20 shoes 132 may be formed with a slot 137 to receive a brush seal 45 or stacked plates 48, 50 forming a secondary seal as described above in connection with a discussion of Figs. 6-8.

-24-

The seal 128 of Figs. 12 and 13 differs from the seal 10 of this invention primarily with respect to the spring elements that support the shoes 132 of seal 128 relative to the rotor 14. The shoes 132 of seal 128 is provided with a radially outwardly extending, 5 circumferential flange 134 formed with a number of sockets 136. The sockets 136 are circumferentially spaced along the flange 134, and are preferably alternately radially spaced from one another. A ring 138 is axially spaced from the shoes 132 and connected to the stator 12. The ring 138 is formed with a number of sockets (not shown) that 10 align with the sockets 136 in the flange 134 of shoes 132. A number of axially extending rods or pins 142 connect the ring 138 and shoes 132. Each pin 142 has a first end mounted within a socket 136 of the flange 134 of a shoe 132, and a second end mounted within an aligning socket on the ring 138. As seen in Figs. 12 and 13, the pins 15 142 are oriented generally parallel to one another when positioned within the sockets 136 in the shoes 132 and ring 138. The pins 142 act as spring elements and deflect in a radial direction in response to the application of aerodynamic forces to the shoes 132, allowing the shoes 132 to "float" at a predetermined clearance or gap 11 relative to 20 the rotor 14.

Referring to Fig. 14, the seal 130 of this embodiment is similar to that of Figs. 12 and 13 except that a number of spring elements or

-25-

rods 144 are welded, brazed or otherwise permanently affixed to each of at least one shoe 146 and a ring 148. For purposes of illustration, two shoes 146 are shown in Fig. 14, the shoe 146 may be provided with a number of openings 150 within which one end of a rod 144 is received and may be welded or brazed in place. The openings 150 are circumferentially spaced along the shoes 146, and alternately radially spaced from one another. The ring 148 is axially spaced from the shoes 146 and fixed to the stator 12. Openings (not shown) are formed in the ring 148 that align with the openings 150 in the shoes 146 to receive and mount the opposite end of each rod 144 so that they are generally parallel to one another.

The rods 144 of seal 130, like the pins 142 of seal 128, act as spring elements and deflect in a radial direction in response to the application of aerodynamic forces to the shoes 146, allowing the shoes 146 to "float" at a predetermined clearance or gap 11 relative to the rotor 14. The surface of shoes 146 that faces the rotor 14 may be formed with one of the surface geometries shown in Figs. 10A to 10G, and it may further include labyrinth-type tooth elements 110 and 112 depicted in Fig. 11. The structure and operation of such surface geometries and tooth elements 110, 112 is the same as that described above in connection with a discussion of Figs. 10A to 11, and the same reference numbers are therefore used in Fig. 14 to denote like

-26-

structure. Additionally, the shoes 146 may be formed with one or more orifices or bleed holes 152 extending into the cavity 118 or 122, one of which is shown within cavity 122 in Fig. 14, for the same purposes as bleed holes 126 and 127 described above in connection
5 with a discussion of Fig. 11. Further, a notch 154 may be formed in one or both of the tooth elements 110 and 112. The bleed hole 152 and/or notch 154 act to prevent a sudden drop in pressure within the cavities 118 and 122 thus assisting in avoiding contact between the shoe 16 and the rotor 14.

10 While the invention has been described with reference to a preferred embodiment, it should be understood by those skilled in the art that various changes may be made and equivalents may be substituted for elements thereof without departing from the scope of the invention. In addition, many modifications may be made to adapt
15 a particular situation or material to the teachings of the invention without departing from the essential scope thereof. Therefore, it is intended that the invention not be limited to the particular embodiments disclosed as the best mode contemplated for carrying out the invention, but that the invention will include all embodiments
20 falling within the scope of the appended claims.

What is claimed is:

-27-

1. A seal for sealing a circumferential gap between a first machine component and a second machine component which is rotatable relative to the first machine component about a longitudinal axis, comprising:

5 at least one shoe having a first surface and a second surface spaced from said first surface, said first surface extending along one of said first and second machine components in a position to create a non-contact seal therewith;

a ring spaced from said at least one shoe along said
10 longitudinal axis, said ring being mounted to one of the first and second machine components;

a number of spring elements connected between said at least one shoe and said ring, said spring elements being effective to deflect and move with said at least one shoe in response to the
15 application of aerodynamic forces to said at least one shoe in such a way as to assist in the creation of a primary seal of the circumferential gap between the first and second machine components.

2. The seal of claim 1 in which said spring elements are substantially parallel to one another.

-28-

3. The seal of claim 1 in which said spring elements each have a first end secured within a socket in said ring and a second end secured to a socket in said at least one shoe.

4. The seal of claim 1 in which said spring elements each have a first end fixed to said ring and a second end fixed to said at least one shoe.

5. The seal of claim 1 in which said at least one shoe is subjected to aerodynamic forces applied in a direction along said longitudinal axis, said at least one shoe being formed with a radially inwardly extending sealing area and at least one tooth element mounted to said at least one shoe in a position upstream from said sealing area, a first cavity being formed between said at least one tooth element and said sealing area.

6. The seal of claim 5 in which said at least one tooth element extends from said first surface toward one of the first and second machine components.

7. The seal of claim 6 in which said at least one tooth element is oriented at an angle relative to said first surface in a

-29-

direction opposing said aerodynamic forces applied to said at least one shoe.

8. The seal of claim 5 in which said at least one tooth element comprises a first tooth element and a second tooth element longitudinally spaced from said first tooth element, said first cavity being formed between said first tooth element and said sealing
5 portion of said at least one shoe, a second cavity being formed between said first and second tooth elements.

9. The seal of claim 8 in which said second tooth element is shorter than said first tooth element measured in a direction between said first surface of said at least one shoe and one of the first and second machine components.

10. The seal of claim 5 in which a pressure relief opening is formed in said at least one tooth element.

11. The seal of claim 5 in which a bleed hole is formed in said at least one shoe, said bleed hole having a first end located at said second surface of said at least one shoe and a second end located at said first surface within said first cavity.

12. The seal of claim 1 further including at least one secondary seal acting on said second surface of said at least one shoe, said at least one secondary seal being effective to deflect and move in response to the application of fluid pressure to said at least one shoe
5 in such a way as to assist in the creation of a secondary seal of the circumferential gap between the first and second machine components.

-31-

13. A seal for sealing a circumferential gap between a first machine component and a second machine component which is rotatable relative to the first machine component about a longitudinal axis, comprising:

- 5 at least one shoe having a first surface and a second surface spaced from said first surface, said at least one shoe being subjected to aerodynamic forces applied in a direction along said longitudinal axis, said first surface being formed with a sealing area extending along one of said first and second machine components in a
- 10 position to form a non-contact seal therewith and at least one tooth element located upstream from said sealing area, a cavity being formed between said sealing area and said at least one tooth element;
- a ring spaced from said at least one shoe along said longitudinal axis, said ring being mounted to one of the first and
- 15 second machine components;
- a number of spring elements connected between said at least one shoe and said ring, said spring elements being effective to deflect and move with said at least one shoe in response to the application of aerodynamic forces to said at least one shoe in such a
- 20 way as to assist in the creation of a primary seal of the circumferential gap between the first and second machine components.

-32-

14. The seal of claim 13 in which said at least one tooth element extends from said first surface toward one of the first and second machine components.

15. The seal of claim 14 in which said at least one tooth element is oriented at an angle relative to said first surface in a direction opposing said aerodynamic forces applied to said at least one shoe.

16. The seal of claim 13 in which said at least one tooth element comprises a first tooth element and a second tooth element longitudinally spaced from said first tooth element, said first cavity being formed between said first tooth element and said sealing
5 portion of said at least one shoe, a second cavity being formed between said first and second tooth elements.

17. The seal of claim 16 in which said second tooth element is shorter than said first tooth element measured in a direction between said first surface of said at least one shoe and one of the first and second machine components.

-33-

18. The seal of claim 13 in which a pressure relief opening is formed in said at least one tooth element.

19. The seal of claim 13 in which a bleed hole is formed in said at least one shoe, said bleed hole having a first end located at said second surface of said at least one shoe and a second end located at said first surface within said first cavity.

20. The seal of claim 13 further including at least one secondary seal acting on said second surface of said at least one shoe and being effective to deflect and move in response to the application of fluid pressure to said at least one shoe in such a way as to assist in
5 the creation of a secondary seal of the circumferential gap between the first and second machine components.

-34-

21. A seal for sealing a circumferential gap between a first machine component and a second machine component which is rotatable relative to the first machine component about a longitudinal axis, comprising:

5 at least one shoe having a first surface and a second surface spaced from said first surface, said first surface being formed with a sealing area extending along one of said first and second machine components in a position to create a non-contact seal therewith;

10 at least one spring element connected between one of the first and second machine components and said second surface of said at least one shoe, said at least one spring element being effective to deflect and move with said at least one shoe in response to the application of aerodynamic forces to said at least one shoe in a
15 direction along said longitudinal axis in such a way as to assist in the creation of a primary seal of the circumferential gap between the first and second machine components;

at least one tooth element mounted to said first surface of said at least one shoe at a location upstream from said sealing
20 area, a cavity being formed between said sealing area and said at least one tooth element.

-35-

22. The seal of claim 21 in which said at least one spring element comprises an outer band and an inner band oriented generally parallel to one another and radially spaced from said one of the first and second machine components.

23. The seal of claim 21 in which said at least one tooth element is oriented at an angle relative to said first surface in a direction opposing said aerodynamic forces applied to said at least one shoe.

24. The seal of claim 21 in which a pressure relief opening is formed in said at least one tooth element.

25. The seal of claim 21 in which a bleed hole is formed in said at least one shoe, said bleed hole having a first end located at said second surface of said at least one shoe and a second end located at said first surface within said first cavity.

26. The seal of claim 21 further including at least one secondary seal acting on said second surface of said at least one shoe, said at least one secondary seal being effective to deflect and move in response to the application of fluid pressure to said at least one shoe

-36-

5 in such a way as to assist in the creation of a secondary seal of the circumferential gap between the first and second machine components.

27. A method of sealing the circumferential gap between a first machine component and a second machine component which is rotatable relative to the first machine component about a longitudinal axis, comprising:

- 5 (a) connecting at least one spring element between one of the first and second machine components and at least one shoe so that a sealing area of said at least one shoe is positioned to create a non-contact seal with the other of the first and second machine components;
- 10 (b) controlling the clearance between said at least one shoe and the other of the first and second machine components by creating a pressure drop in the flow of fluid across said sealing area of said at least one shoe, said pressure drop resulting from the formation of at least one cavity upstream from said sealing area.

28. The method of claim 27 in which step (a) comprises connecting said at least one spring element between a ring mounted to said one of the first and second machine components and said at least one shoe, said ring and said at least one shoe being spaced from
5 one another along said longitudinal axis.

29. The method of claim 27 in which step (b) comprises forming a tooth element along said at least one shoe upstream from

-38-

said sealing area, said at least one cavity being formed between said tooth element and said sealing area of said at least one shoe.

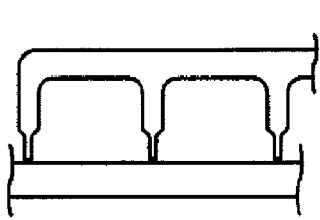

FIG. 1A
PRIOR ART

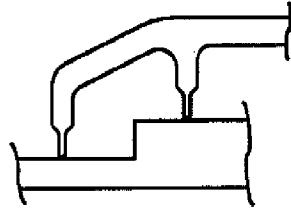

FIG. 1B
PRIOR ART

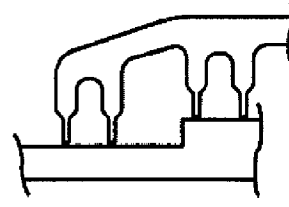

FIG. 1C
PRIOR ART

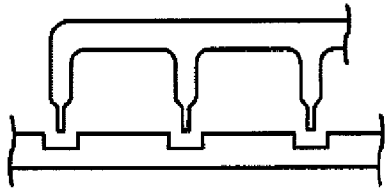

FIG. 1D
PRIOR ART

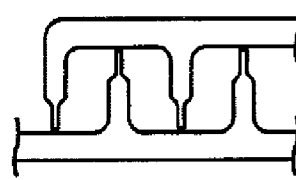

FIG. 1E
PRIOR ART

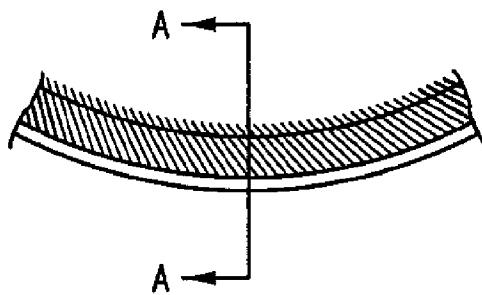

FIG. 2A
PRIOR ART

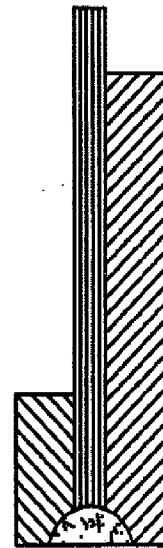

FIG. 2B
PRIOR ART

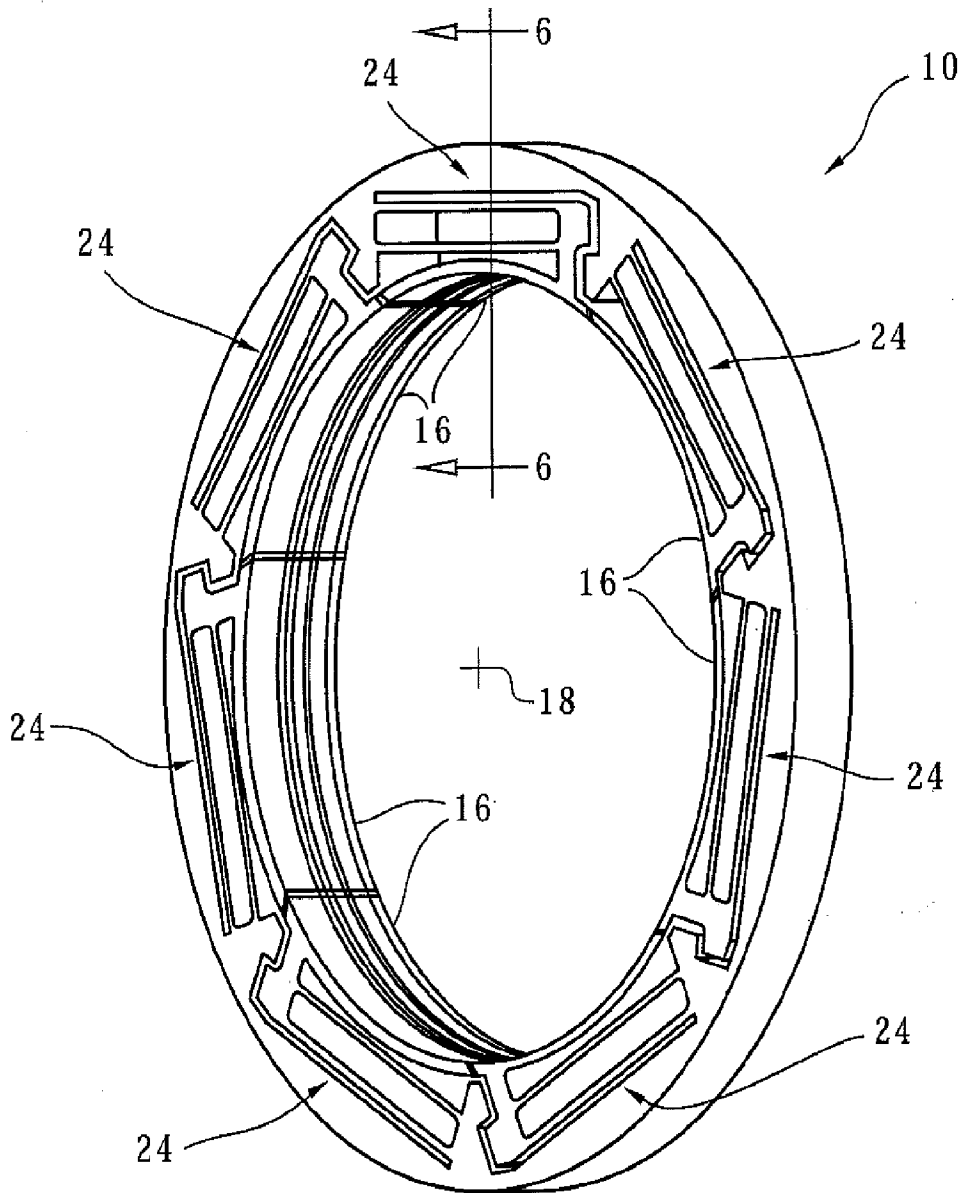

FIG. 3

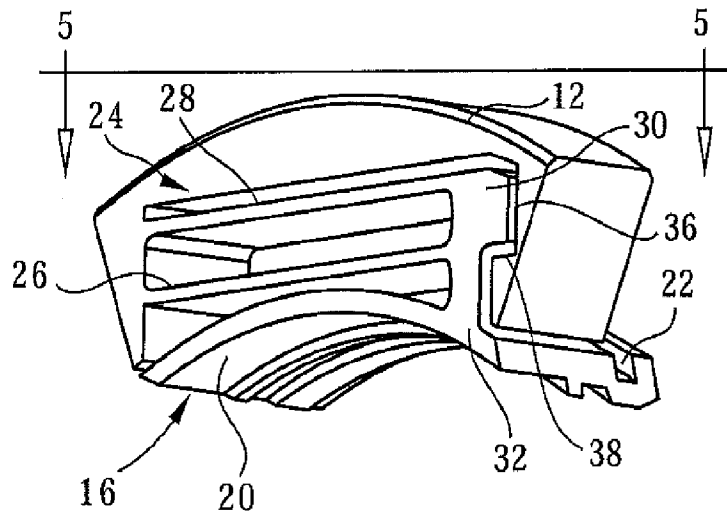

FIG. 4

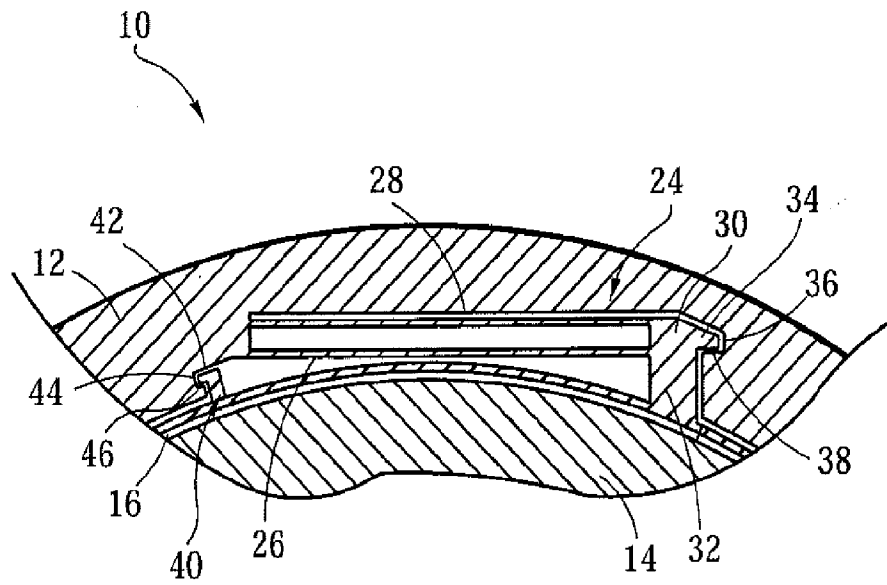

FIG. 5

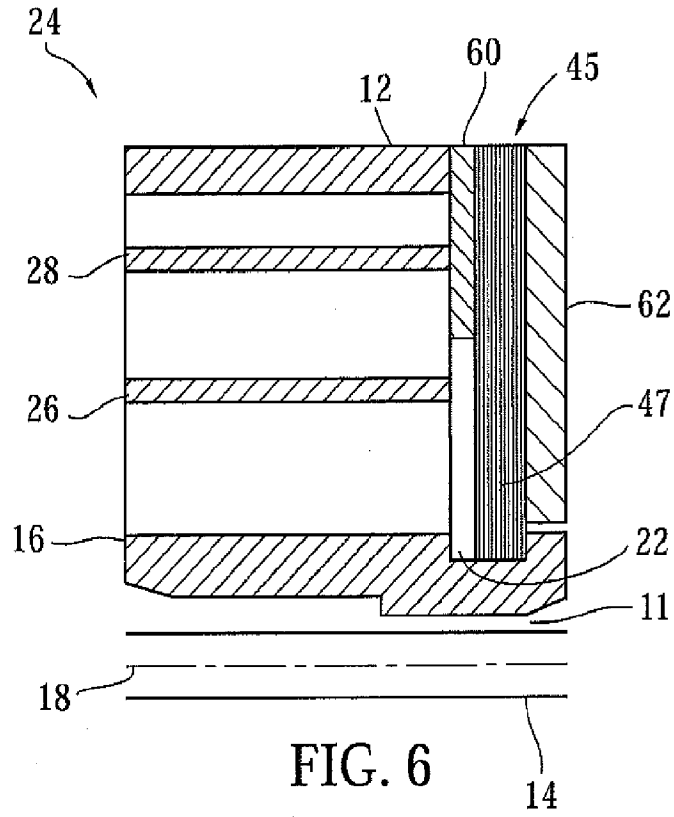

FIG. 6

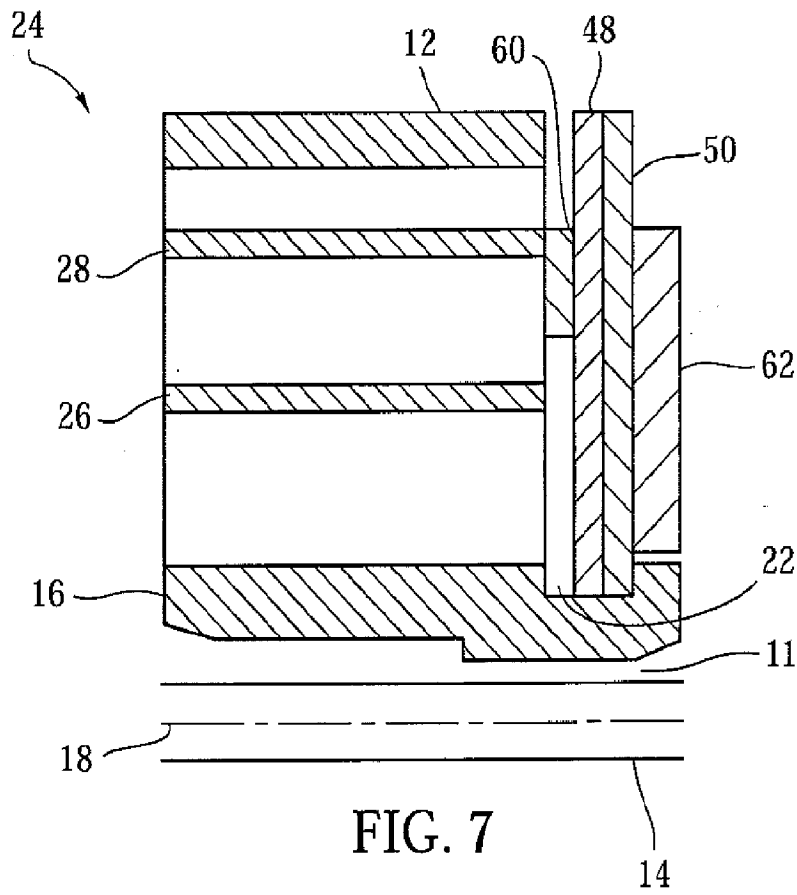

FIG. 7

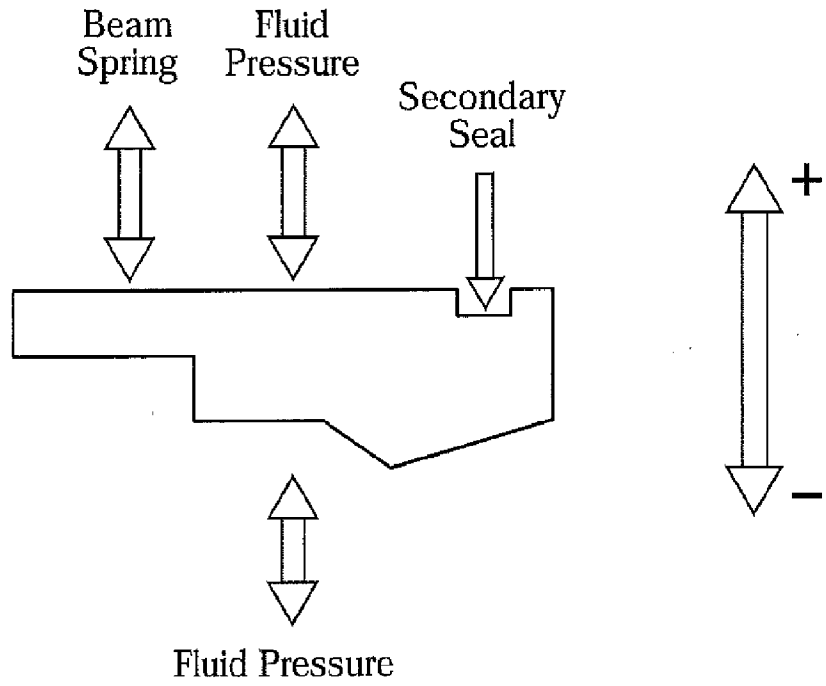
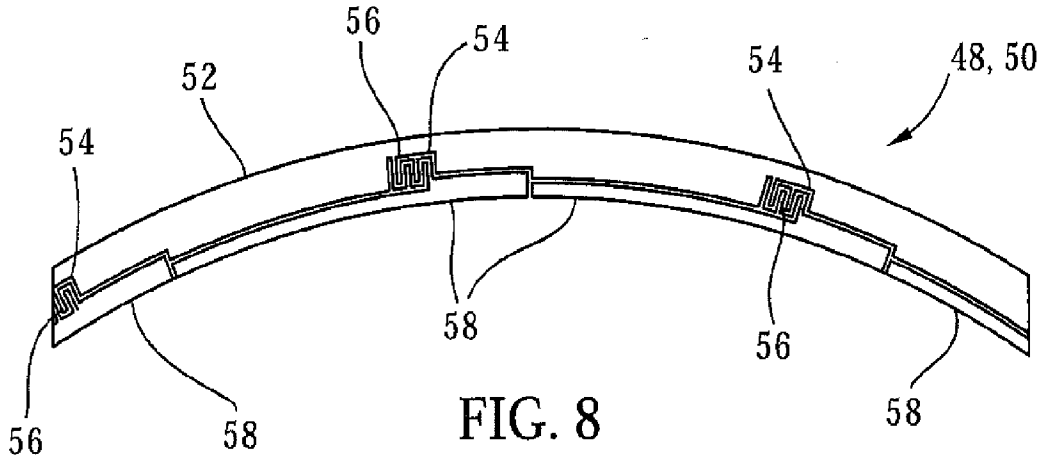
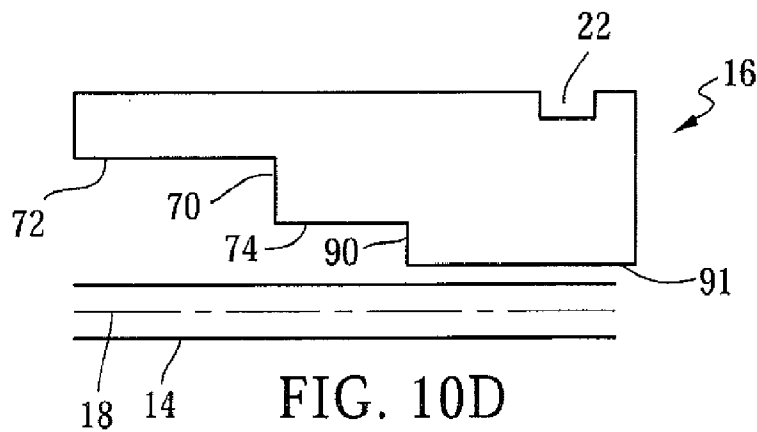
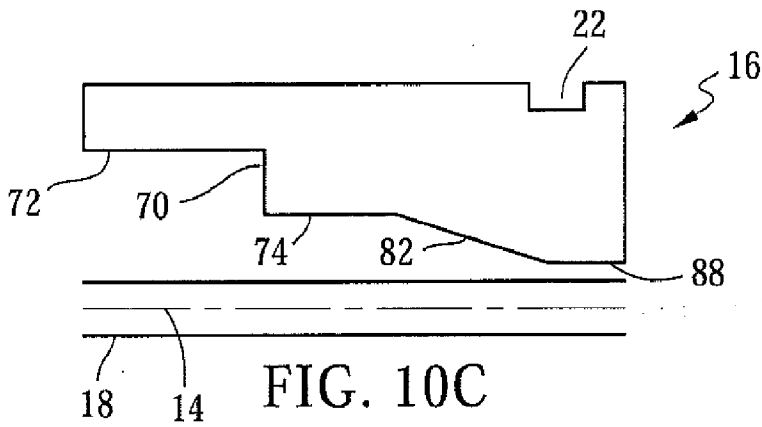
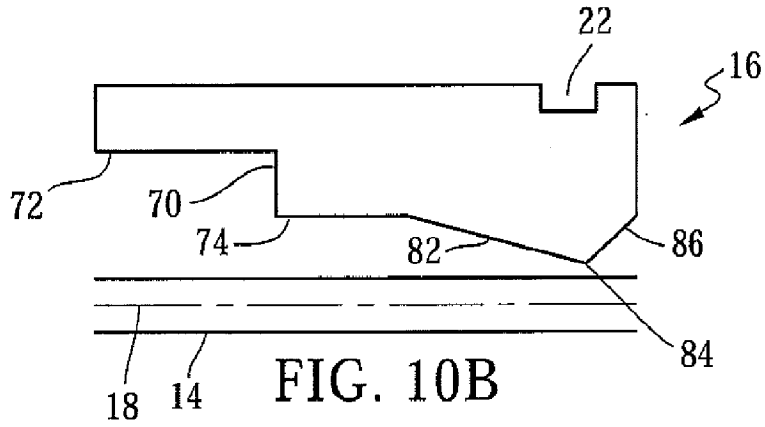
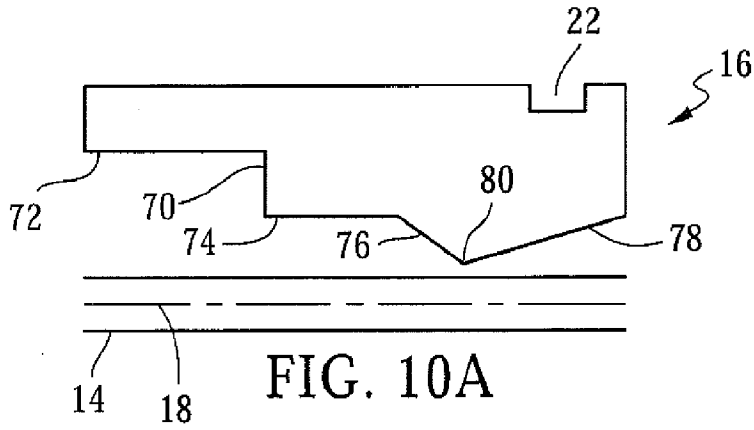
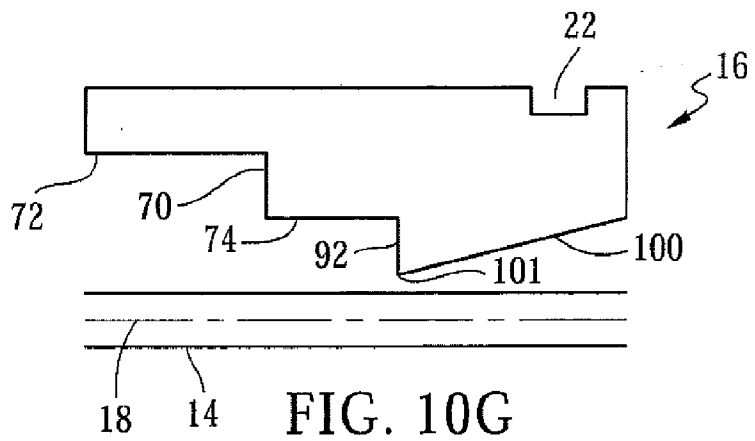
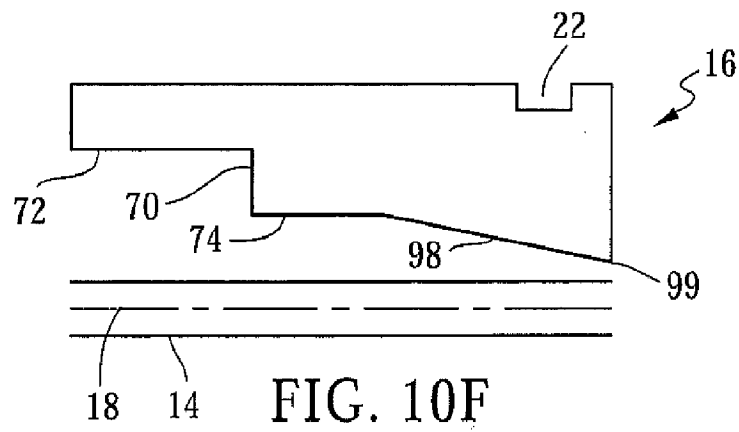
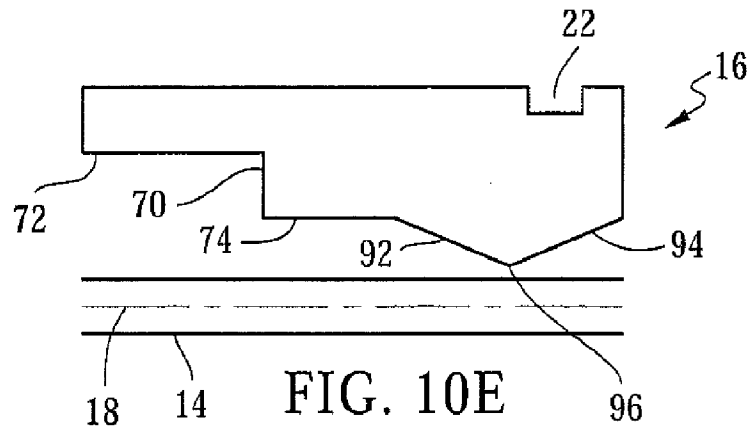

FIG. 9





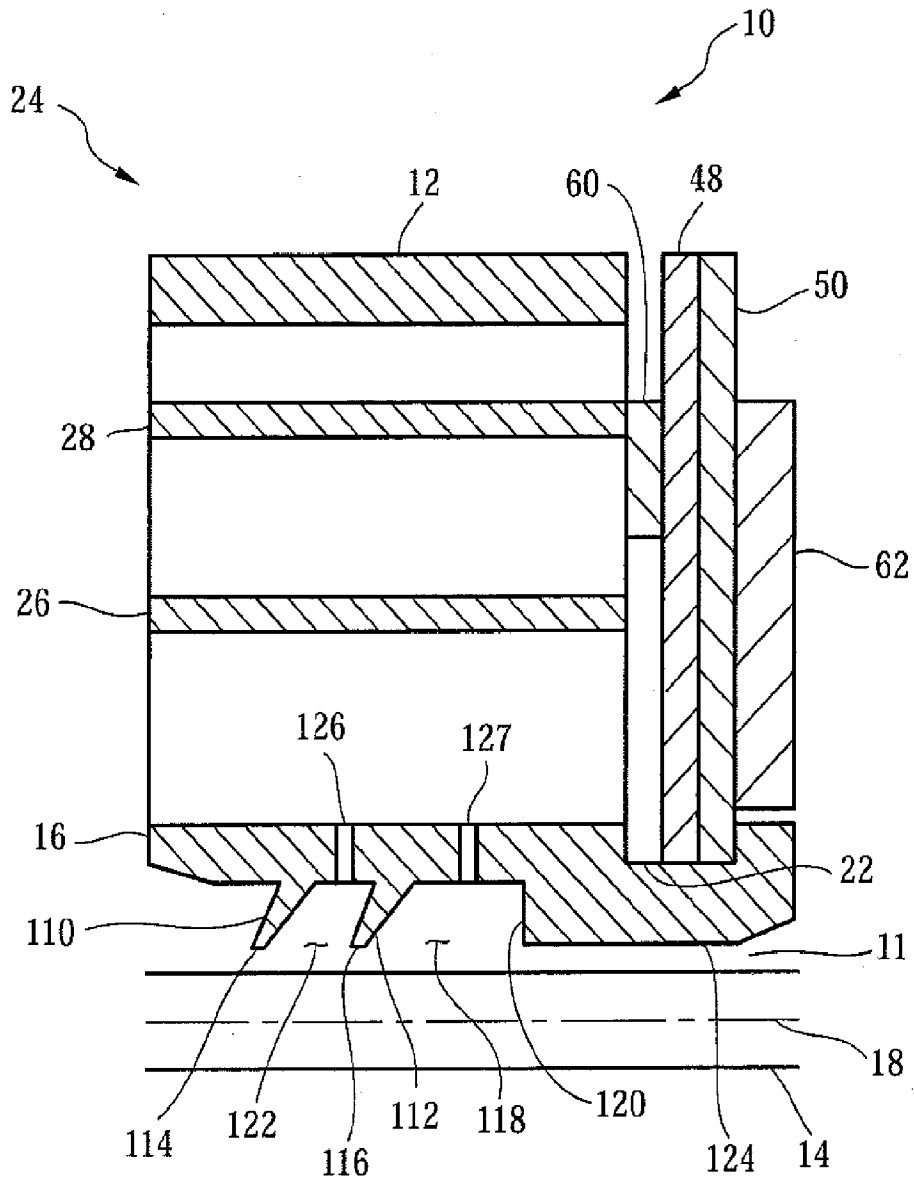

FIG. 11

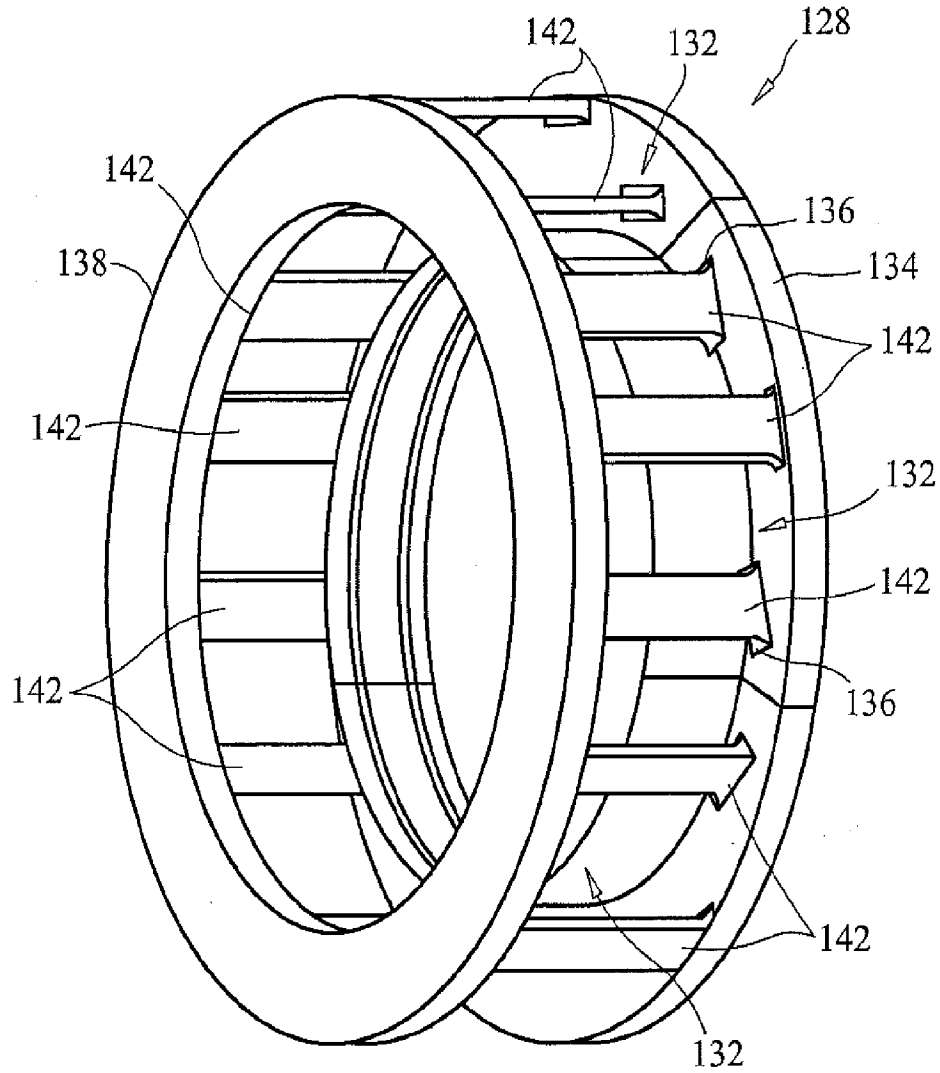

FIG. 12

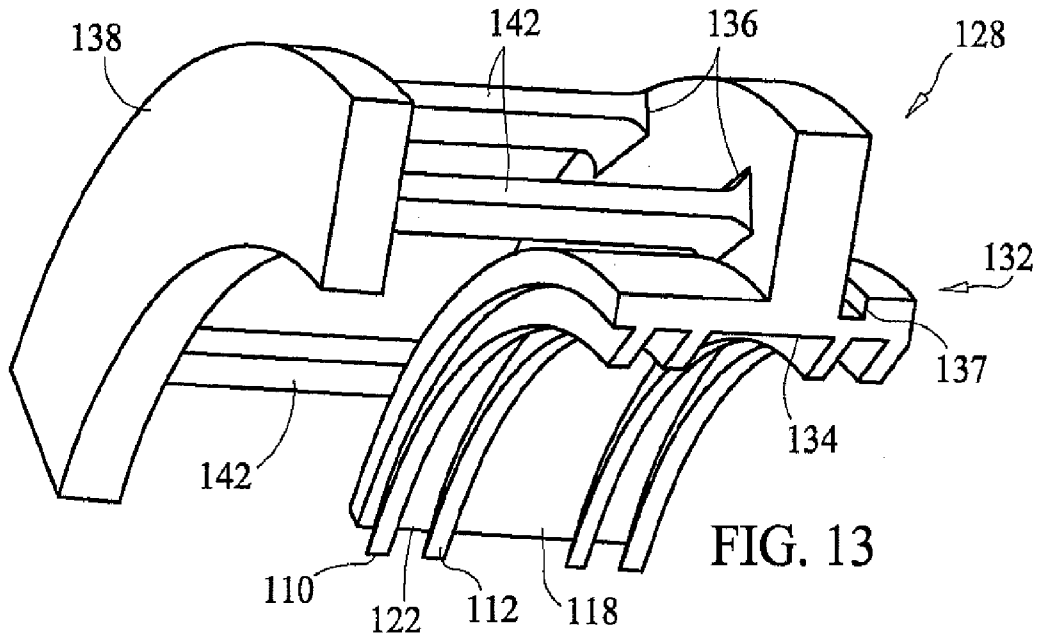

FIG. 13

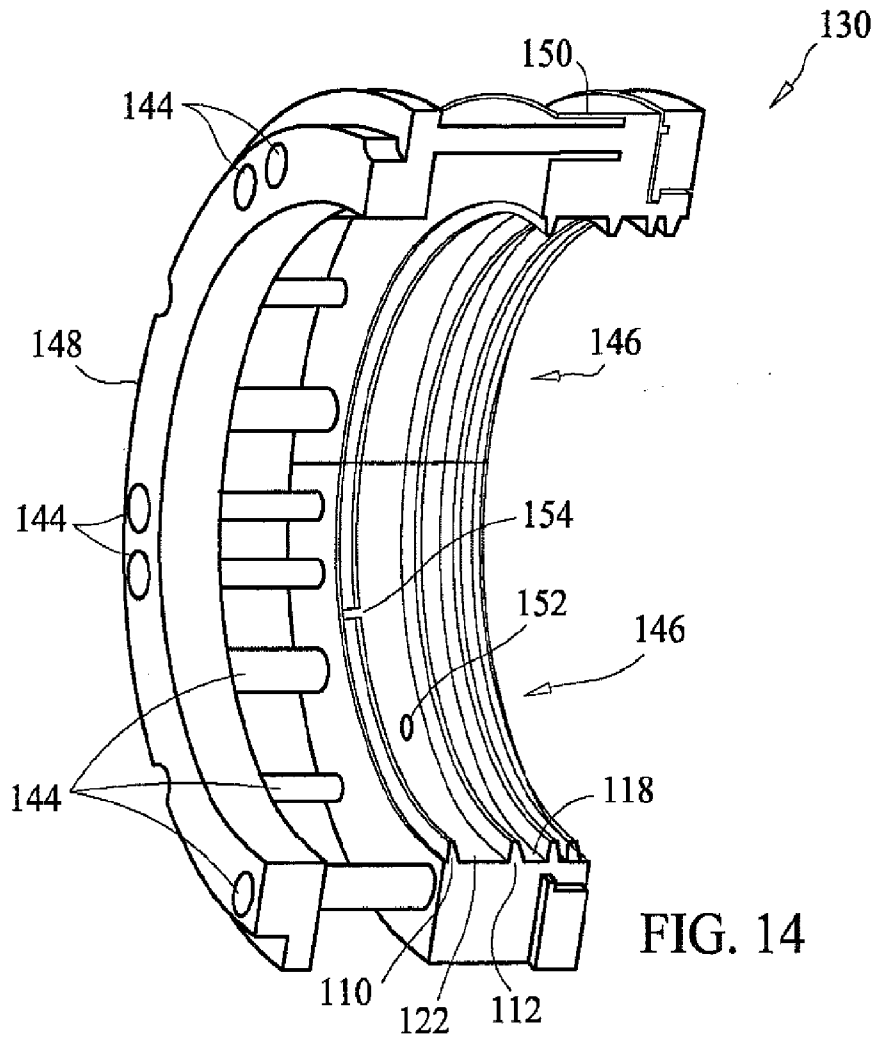

FIG. 14

INTERNATIONAL SEARCH REPORT

International application No
PCT/US2009/043943

A. CLASSIFICATION OF SUBJECT MATTER

INV. F16J15/44 F16J15/447 F01D11/00 F01D11/02

According to International Patent Classification (IPC) or to both national classification and IPC

B. FIELDS SEARCHED

Minimum documentation searched (classification system followed by classification symbols)
F16J F01D

Documentation searched other than minimum documentation to the extent that such documents are included in the fields searched

Electronic data base consulted during the international search (name of data base and, where practical, search terms used)

EPO-Internal

C. DOCUMENTS CONSIDERED TO BE RELEVANT

Category*	Citation of document, with indication, where appropriate, of the relevant passages	Relevant to claim No.
X	US 2008/100000 A1 (JUSTAK JOHN F [US]) 1 May 2008 (2008-05-01)	1-6, 10-14, 18-22, 24-29
Y	the whole document	7-9, 15-17,23
X	EP 1 420 145 A (ROLLS ROYCE PLC [GB]) 19 May 2004 (2004-05-19)	1-4, 10-12, 18-20, 22,24-29
Y	columns 1-3; figures 1-14	5-9, 13-17, 21,23
	----- -/--	

Further documents are listed in the continuation of Box C.

See patent family annex.

* Special categories of cited documents :

- *A* document defining the general state of the art which is not considered to be of particular relevance
- *E* earlier document but published on or after the international filing date
- *L* document which may throw doubts on priority claim(s) or which is cited to establish the publication date of another citation or other special reason (as specified)
- *O* document referring to an oral disclosure, use, exhibition or other means
- *P* document published prior to the international filing date but later than the priority date claimed

- *T* later document published after the international filing date or priority date and not in conflict with the application but cited to understand the principle or theory underlying the invention
- *X* document of particular relevance; the claimed invention cannot be considered novel or cannot be considered to involve an inventive step when the document is taken alone
- *Y* document of particular relevance; the claimed invention cannot be considered to involve an inventive step when the document is combined with one or more other such documents, such combination being obvious to a person skilled in the art.
- *Z* document member of the same patent family

Date of the actual completion of the international search

7 July 2009

Date of mailing of the international search report

17/07/2009

Name and mailing address of the ISA/
European Patent Office, P.B. 5818 Patentlaan 2
NL - 2280 HV Rijswijk
Tel. (+31-70) 340-2040,
Fax: (+31-70) 340-3016

Authorized officer

Bindreiff, Romain

INTERNATIONAL SEARCH REPORT

International application No
PCT/US2009/043943

C(Continuation). DOCUMENTS CONSIDERED TO BE RELEVANT		
Category*	Citation of document, with indication, where appropriate, of the relevant passages	Relevant to claim No.
Y	EP 0 623 768 A (DRESSER RAND CO [US]) 9 November 1994 (1994-11-09) columns 1-2 column 8, lines 6-21; figures 2-4 -----	5-9, 13-17, 21,23
X	DE 484 540 C (ERSTE BRUENNER MASCHINEN FAB) 16 October 1929 (1929-10-16) page 1, lines 39-58; figures 1,2 -----	1

INTERNATIONAL SEARCH REPORT

Information on patent family members

International application No PCT/US2009/043943
--

Patent document cited in search report	Publication date	Patent family member(s)	Publication date
US 2008100000	A1	01-05-2008	NONE
EP 1420145	A	19-05-2004	DE 60319489 T2 12-03-2009
			GB 2395240 A 19-05-2004
			US 2004150164 A1 05-08-2004
EP 0623768	A	09-11-1994	DE 69411227 D1 30-07-1998
			DE 69411227 T2 17-12-1998
			JP 3220891 B2 22-10-2001
			JP 7071621 A 17-03-1995
			US 5403019 A 04-04-1995
DE 484540	C	16-10-1929	NONE