



US00D796838S

(12) **United States Design Patent**
Sijmons et al.

(10) **Patent No.:** **US D796,838 S**

(45) **Date of Patent:** **** Sep. 12, 2017**

(54) **LUGGAGE**

(71) Applicant: **Samsonite IP Holdings S.a r.l.**,
Luxembourg (LU)

(72) Inventors: **Erik Sijmons**, Oudenaarde (BE);
Adrien Lefebvre, Marcq en Baroeul
(FR)

(73) Assignee: **Samsonite IP Holdings S.a r.l.**,
Luxembourg (LU)

D710,610 S * 8/2014 Sijmons D3/279
D711,104 S * 8/2014 Lai D3/279
D722,771 S * 2/2015 Wu D3/279
D740,557 S * 10/2015 Liao D3/279
D740,558 S * 10/2015 Liao D3/279
D758,076 S * 6/2016 Boer D3/274
D771,382 S * 11/2016 Maeda D3/279
D783,282 S * 4/2017 Sijmons D3/279
2014/0041978 A1* 2/2014 Chang A45C 7/0018
190/18 A
2017/0079398 A1* 3/2017 Reh A45C 13/42

* cited by examiner

(**) Term: **15 Years**

Primary Examiner — Jennifer Rivard

(21) Appl. No.: **29/588,760**

Assistant Examiner — April Rivas

(22) Filed: **Dec. 22, 2016**

(74) *Attorney, Agent, or Firm* — Dorsey & Whitney LLP

(30) **Foreign Application Priority Data**

(57) **CLAIM**

Jul. 1, 2016 (EM) 003261668-0001

The ornamental design for a luggage, as shown and described.

(51) **LOC (10) Cl.** **03-01**

(52) **U.S. Cl.**
USPC **D3/279**

(58) **Field of Classification Search**
USPC D3/273, 276, 279, 281, 282, 289, 291,
D3/902, 272
CPC A45C 5/00; A45C 5/03; A45C 2005/037;
A45C 5/14; A45C 7/0027; A45C 7/0018;
A45C 2005/032; A45C 2005/035; A45C
5/04

See application file for complete search history.

DESCRIPTION

FIG. 1 shows a front perspective view of the luggage;
FIG. 2 shows a front elevation view of the luggage of FIG. 1;
FIG. 3 shows a rear elevation view of the luggage of FIG. 1;
FIG. 4 shows a right elevation view of the luggage of FIG. 1;
FIG. 5 shows a left elevation view of the luggage of FIG. 1;
FIG. 6 shows a top view of the luggage of FIG. 1; and,
FIG. 7 shows a bottom view of the luggage of FIG. 1.
The broken lines in FIGS. 1-7 illustrate portions of the luggage and form no part of the claimed design.

(56) **References Cited**

U.S. PATENT DOCUMENTS

D629,200 S * 12/2010 Turella-Yuan D3/279
D659,395 S * 5/2012 Sijmons D3/279

1 Claim, 7 Drawing Sheets

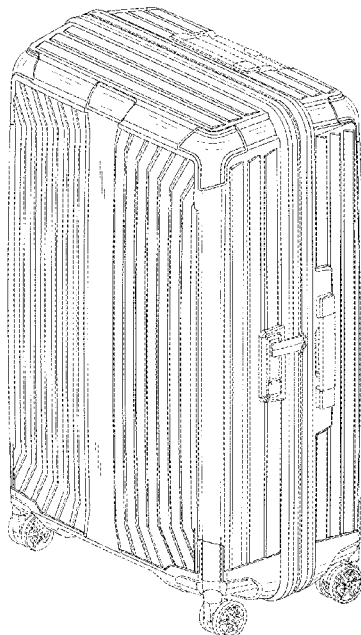

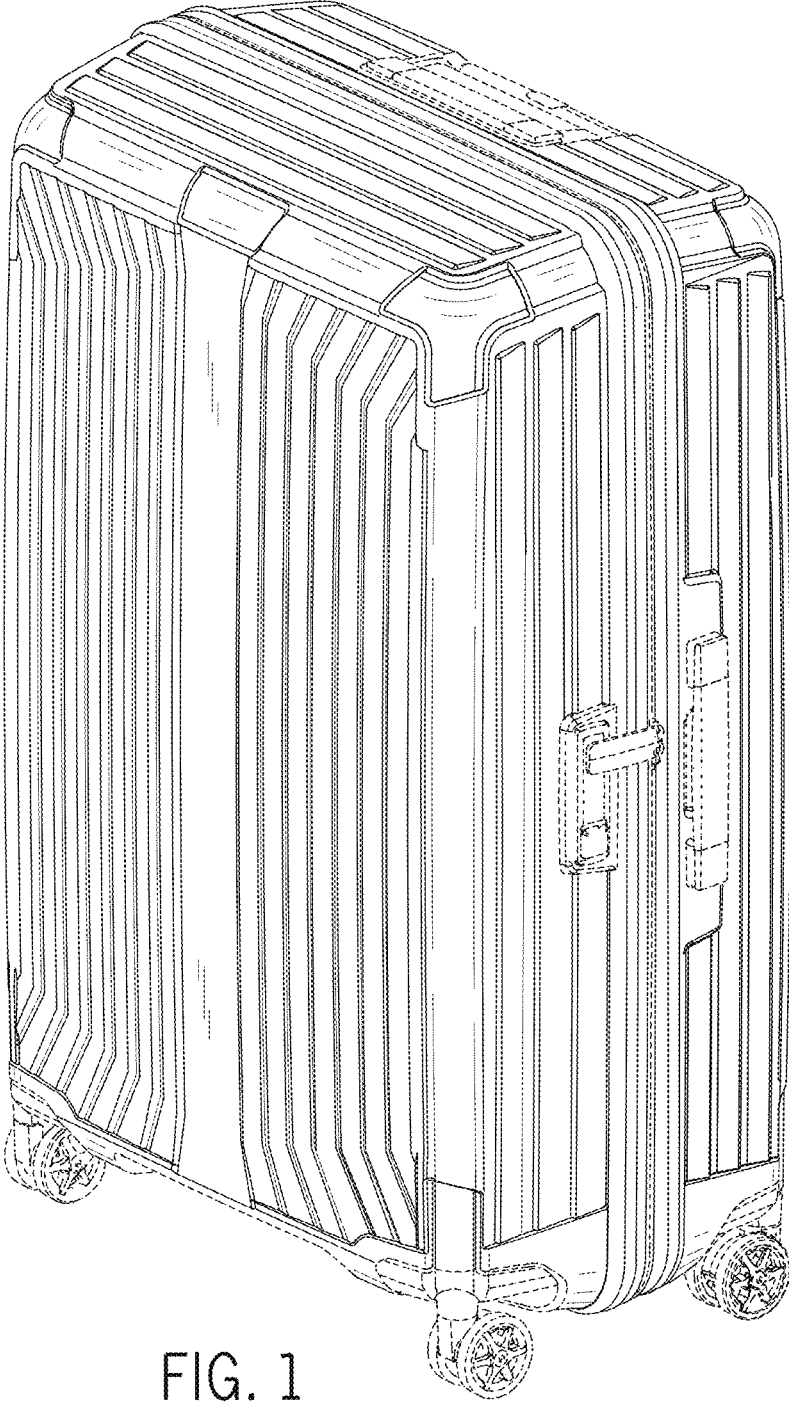

FIG. 1

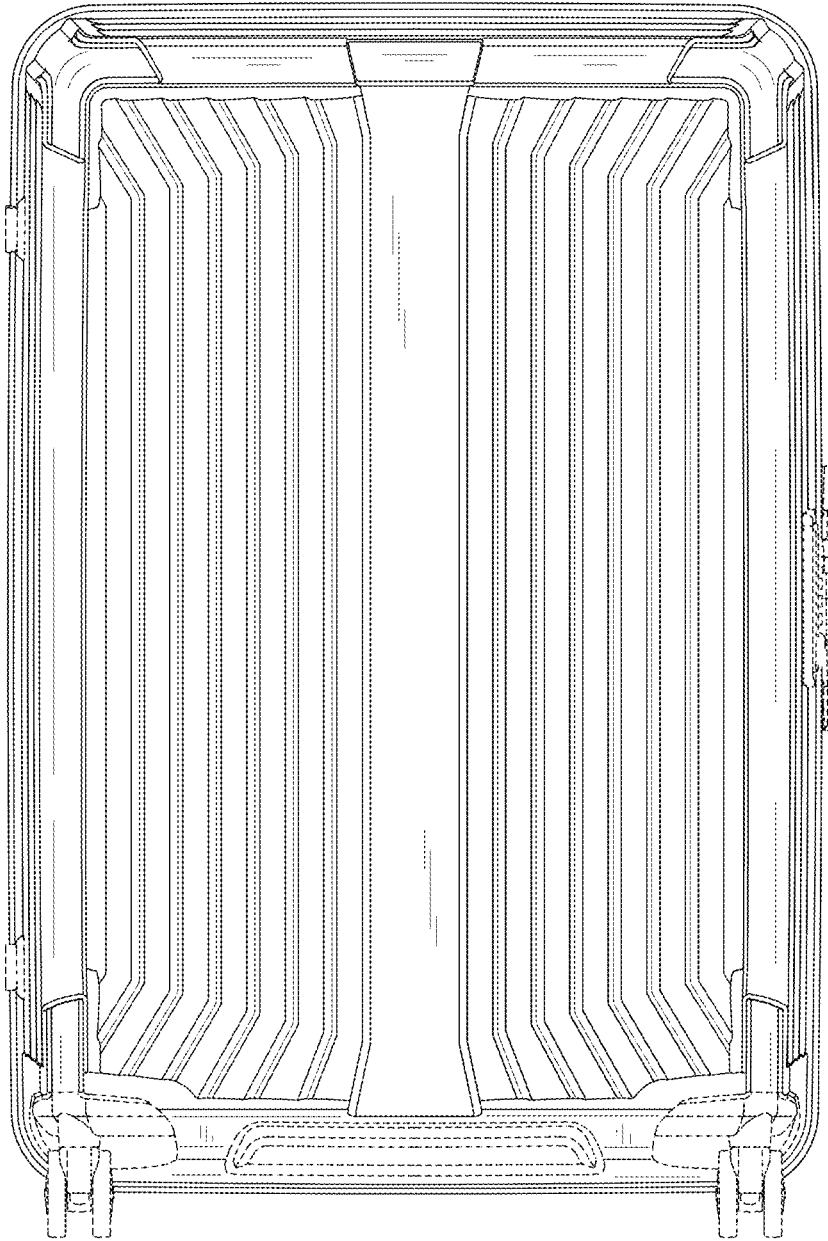

FIG. 2

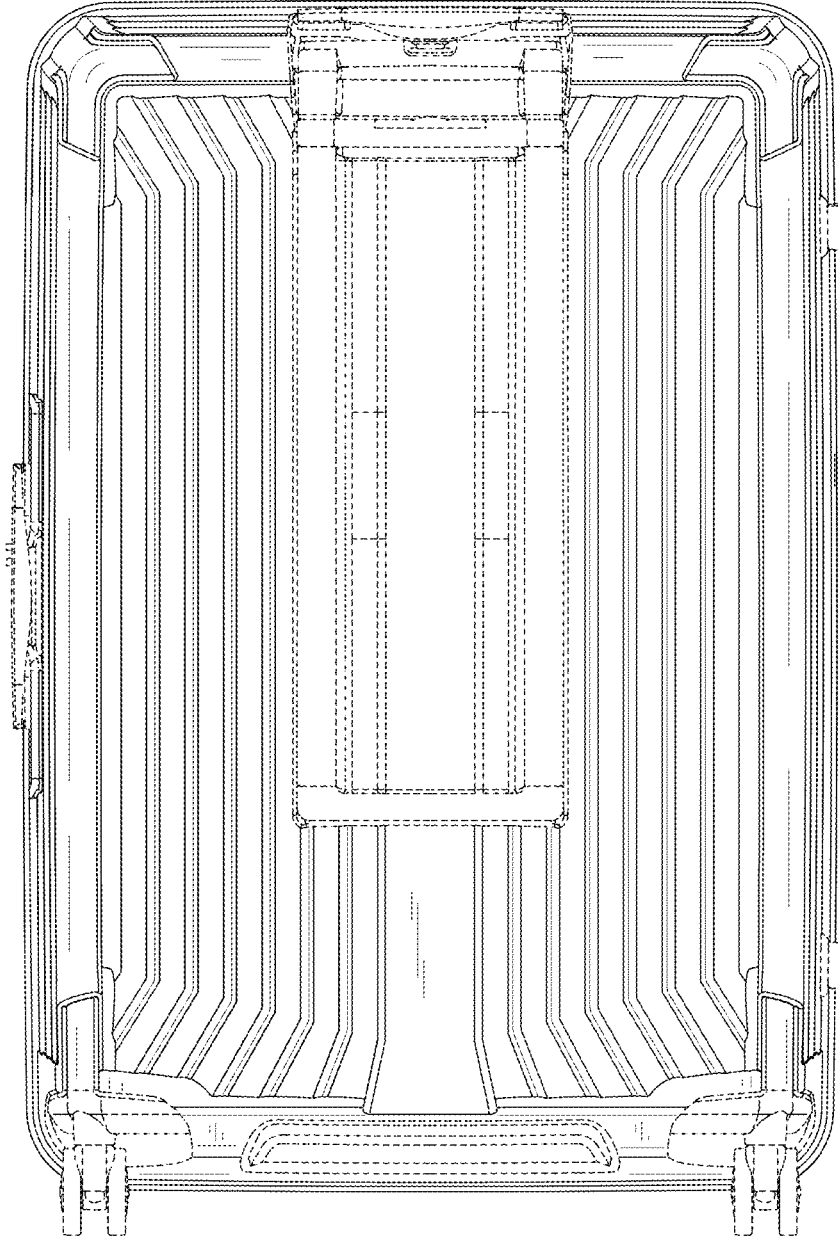

FIG. 3

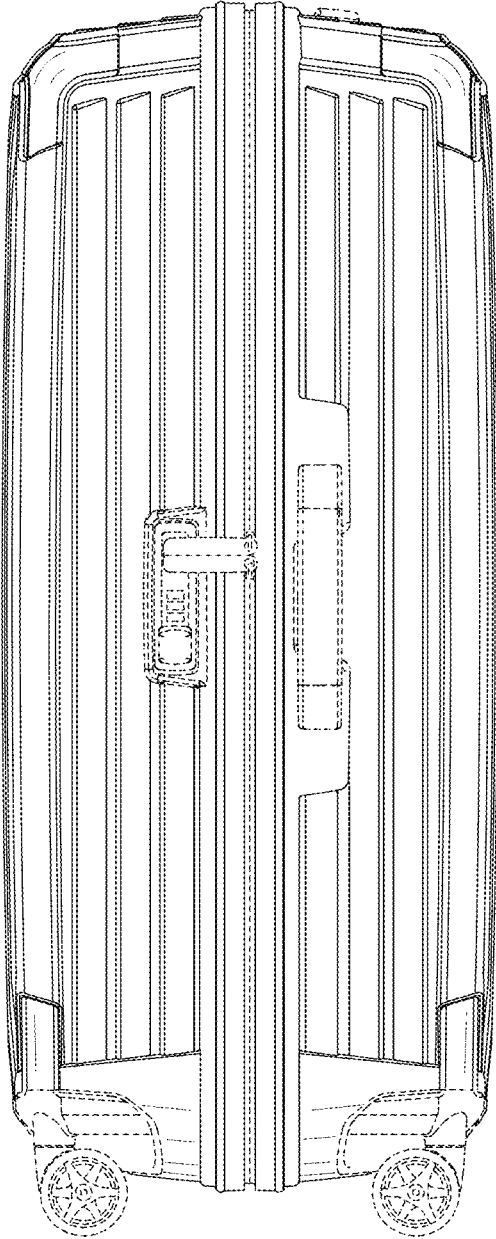

FIG. 4

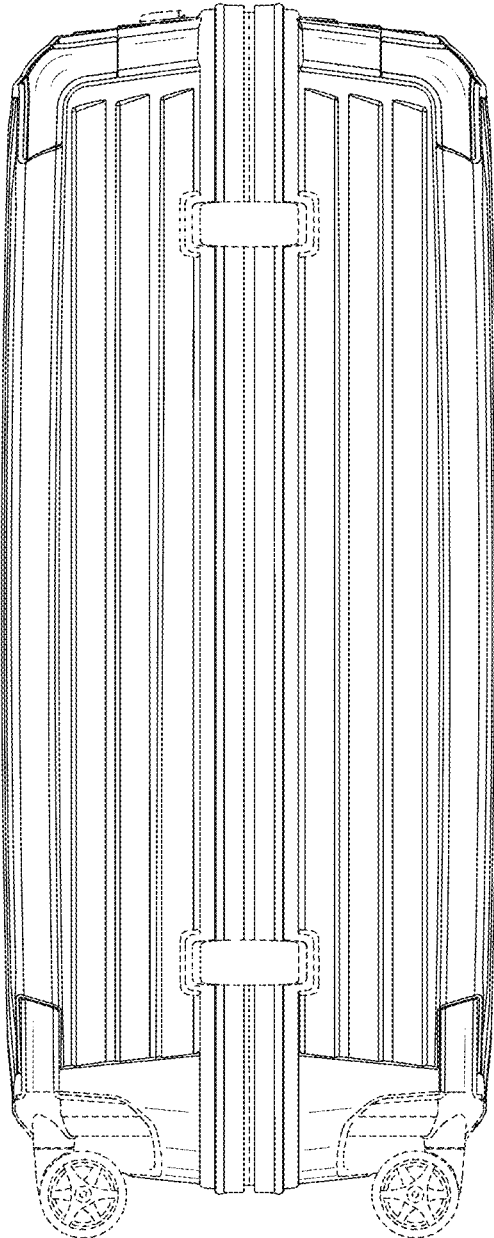

FIG. 5

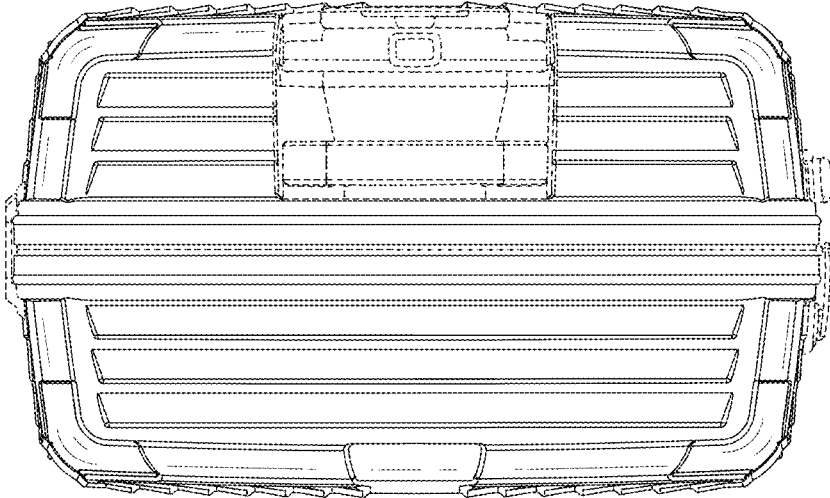

FIG. 6

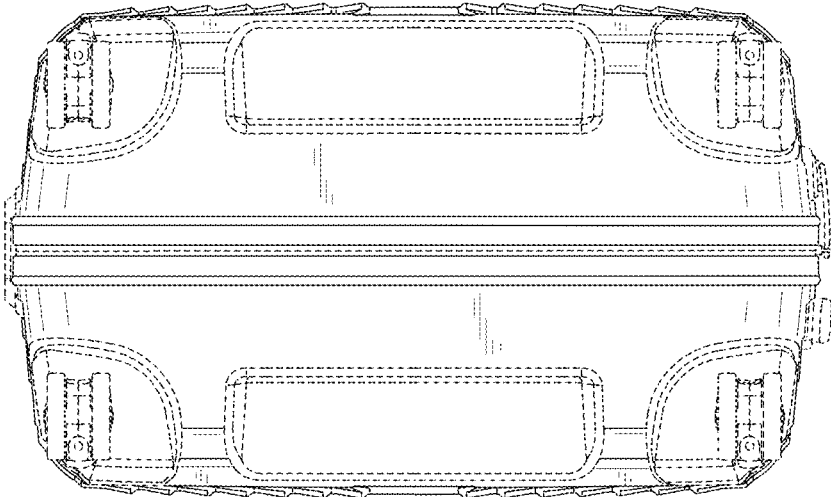

FIG. 7