

**(12) PATENT ABRIDGMENT (11) Document No. AU-B-22176/88**  
**(19) AUSTRALIAN PATENT OFFICE (10) Acceptance No. 605908**

(54) Title  
**SATELLITE COMMUNICATIONS SYSTEM EMPLOYING FREQUENCY REUSE**

International Patent Classification(s)  
(51)<sup>4</sup> **H04B 007/185 H01Q 025/00**

(21) Application No. : **22176/88** (22) Application Date : **13.09.88**

(30) Priority Data

(31) Number (32) Date (33) Country  
**108831 14.10.87 US UNITED STATES OF AMERICA**

(43) Publication Date : **11.05.89**

(44) Publication Date of Accepted Application : **24.01.91**

(71) Applicant(s)  
**HUGHES AIRCRAFT COMPANY**

(72) Inventor(s)  
**HAROLD A. ROSEN**

(74) Attorney or Agent  
**GRIFFITH HACK & CO., GPC Box 4164, SYDNEY NSW 2001**

(56) Prior Art Documents  
**AU 81706/87 H04B 1/185 7/26**  
**AU 77459/87 H04B 7/185 H04L 7/08 5/22**  
**AU 567552 26199/84 H04L 5/14 H04B 7/185 H04J 3/14 25/38**

(57) Claim

1. A method of communicatively interconnecting any of a plurality of terminals within an area on the earth using an earth-orbiting communications satellite, comprising the steps of:

(A) forming a first plurality of groups of radio frequency beams respectively between each of a plurality of essentially contiguous zones covering said area on the earth and said satellite, the beams in said groups thereof carrying communications signals over the same first preselected range of frequencies, such that said first preselected range of frequencies is reused by the beams of all of said zones;

(B) separating each group of said radio frequency beams into first and second sets thereof respectively

(11) AU-B-22176/88  
(10) 605908

-2-

carrying communications signals over first and second sets of frequencies within said first preselected range of frequencies, and spatially distributing said first preselected range of frequencies over each of the zones as a function of frequency such that the frequencies of one set of said beams in one zone is spatially separated from the frequencies of one set of said beams in a zone substantially contiguous to said one zone;

(C) alternately transmitting the first and second sets of said beams between said zones and said satellite by simultaneously transmitting the beams in the first set thereof for all the zones and then simultaneously transmitting the beams in the second set thereof for all the zones.

605908

COMMONWEALTH OF AUSTRALIA

PATENTS ACT 1952

Form 10

COMPLETE SPECIFICATION

FOR OFFICE USE

Short Title:

Int. Cl:

Application Number:  
Lodged:

Complete Specification-Lodged:  
Accepted:  
Lapsed:  
Published:

Priority:

Related Art:

---

TO BE COMPLETED BY APPLICANT

Name of Applicant: HUGHES AIRCRAFT COMPANY  
Address of Applicant: 7200 Hughes Terrace, Los Angeles,  
CALIFORNIA 90045-0066, U.S.A.  
Actual Inventor: Harold A. Rosen  
Address for Service: GRIFFITH HACK & CO.  
71 YORK STREET  
SYDNEY NSW 2000  
AUSTRALIA

Complete Specification for the invention entitled:

SATELLITE COMMUNICATIONS SYSTEM  
EMPLOYING FREQUENCY REUSE

The following statement is a full description of this invention,  
including the best method of performing it known to me/us:-

9714A:rk

SATELLITE COMMUNICATIONS SYSTEM  
EMPLOYING FREQUENCY REUSE

TECHNICAL FIELD

5                   The present invention broadly relates to satellite  
communication systems especially of the type employing a satellite placed in  
geosynchronous orbit above the earth so as to form a communication link  
between many small aperture terminals on the earth. More particularly, the  
invention involves a communication satellite having hybrid communication  
10                   capability accommodating both two-way and broadcast communication  
systems. Two-way communications between small aperture earth terminals is  
achieved through multi-fold reuse of a fixed frequency spectrum in  
contiguous zones of an area on the earth.

BACKGROUND ART

15                   In domestic communication satellite systems, which  
interconnect large numbers of very small aperture earth terminals, the most  
important parameters affecting the system capacity are the Effective Isotropic  
Radiated Power (EIRP) and the available bandwidth. EIRP refers to a  
measure of the satellite's transmitter power which takes into consideration the  
20                   gain of the antenna. EIRP is the power of a transmitter and isotropic antenna  
that would achieve the same result as the transmitter and antenna which is  
actually employed.



In the past, high antenna gain and multiple frequency reuse has been achieved by employing a plurality of up and down link beams covering the regions of a country or other areas of the earth to be served. Both frequency division and time division systems have been used or proposed to interconnect large numbers of signals from many geographically separated earth stations. Time division systems permit the satellite transmitters to operate efficiently. This is because only one time division signal at a time is amplified in a transmitter, so it may be operated at or close to signal channel saturation, the most efficient operating point. However, time division systems require high power ground transmitters and expensive signal processing and are therefore incompatible with low cost earth stations. Frequency division systems are better suited to low cost earth stations, but have lower satellite transmitter efficiency because each transmitter handles multiple carriers. Since multiple carrier amplifiers generate undesirable intermodulation products that increase in power as the transmitter efficiency is increased, the optimum compromise between transmitter efficiency and intermodulation product generation results in a relatively low transmitter efficiency.

In Ku band, the satellite communication band most suitable for two-way service between very small terminals, the attenuation of the signals by rain is an important consideration in the design of the system. In the previous systems, this attenuation is overcome on the downlink by using higher satellite transmitter power per channel than would be necessary for clear weather service, typically four times as much. This accommodation of rain attenuation therefore results in more expensive satellites having fewer available channels.

The available bandwidth of a satellite system is determined by the number of times the allocated frequency spectrum can be reused. Polarization and spatial isolation of beams have been employed to permit reuse of the frequency spectrum. As the number of isolated beams is increased, however, the problem of interconnecting all the users becomes very complicated and is one of the factors that limit the number of reuses of the frequency spectrum.

The present invention is directed toward overcoming each of the deficiencies mentioned above.

SUMMARY OF THE INVENTION

5

According to one aspect of the present invention, there is provided a method of communicatively interconnecting any of a plurality of terminals within an area on the earth using an earth-orbiting communications satellite, comprising the steps of:

10

(A) forming a first plurality of groups of radio frequency beams respectively between each of a plurality of essentially contiguous zones covering said area on the earth and said satellite, the beams in said groups thereof carrying communications signals over the same first preselected range of frequencies, such that said first preselected range of frequencies is reused by the beams of all of said zones;

15

(B) separating each group of said radio frequency beams into first and second sets thereof respectively carrying communications signals over first and second sets of frequencies within said first preselected range of frequencies, and spatially distributing said first preselected range of frequencies over each of the zones as a function of frequency such that the frequencies of one set of said beams in one zone is spatially separated from the frequencies of one set of said beams in a zone substantially contiguous to said one zone;

20

25

7717S/NL



(C) alternately transmitting the first and second sets of said beams between said zones and said satellite by simultaneously transmitting the beams in the first set thereof for all the zones and then simultaneously  
5 transmitting the beams in the second set thereof for all the zones.

According to another aspect of the present invention there is provided the method of claim 5, wherein the sets of frequencies of said contiguous two sections are different  
10 from each other, whereby to avoid communications interference between said contiguous two sections.

According to another aspect of the present invention there is provided a satellite communications system for  
15 communicatively interconnecting a plurality of earth terminals covering an area on the earth, comprising:  
a satellite disposed in orbit above the earth;  
first means for forming a plurality of uplink radio frequency beams between said satellite and each of a  
20 plurality of respectively associated zones covering said area, said zones being divided into at least two sections, each plurality of said uplink beams carrying communications signals destined to be received by downlink terminal sites  
in said zones, the uplink beams for each zone being arranged  
25 in first and second sets of said beams respectively originating from said two sections in the zone and carrying communication signals over first and second sets of frequencies, said first and second set of frequencies

7717S/NL



defining a first range of frequencies, the uplink beams for all of said zones using said first range of frequencies;

second means at said satellite for alternately receiving said first and second sets of beams; and

5 third means at said satellite coupled with said second means for forming a plurality of groups of downlink radio frequency beams between said satellite and said zones, each of said groups of downlink beams carrying communication signals destined to be received at downlink terminal sites  
10 in one of said zones.

BRIEF DESCRIPTION OF THE DRAWINGS

In the accompanying drawings:

15 Figure 1 is a perspective view of a communications satellite, showing the antenna subsystems;

Figure 2 is a top plan view of the antenna subsystems shown in Figure 1;

20 Figure 3 is a sectional view taken along the line 3-3 in Figure 2;

Figure 4 is a sectional view taken along the line 4-4 in Figure 2;

25 Figure 5 is a view of the United States and depicts multiple, contiguous receive zones covered by the satellite of the present invention, the primary areas of coverage being indicated in cross-hatching and the areas of contention being indicated by a dimpled pattern;

Figure 6 is a block diagram of the communication





electronics for the communications satellite;

Figure 7 is a schematic diagram of a coupling network which interconnects the point-to-point receive feed horns with the inputs to the communications electronics shown in

5 Figure 6;

10

15

20

25

7717S/NL



Figure 8 is a reference table of the interconnect channels employed to connect the receive and transmit zones for the point-to-point system;

5 Figure 9 is a diagrammatic view of the United States depicting multiple contiguous transmit zones covered by the satellite and the geographic distribution of the interconnected channels for each zone, across the United States;

10 Figure 9A is a graph showing the variation in gain of the transmit antenna beam for each zone in the point-to-point system in relation to the distance from the center of the beam in the east-west direction;

Figure 9B is a graph similar to Figure 9A but showing the variation in gain in the north-south direction;

15 Figure 10 is a detailed schematic diagram of the filter interconnection matrix employed in the point-to-point system;

20 Figure 11 is a detailed, plan view of the beam-forming network employed in the point-to-point system;

Figure 12 is an enlarged, fragmentary view of a portion of the beam-forming network shown in Figure 11;

25 Figure 13 is a front elevational view of the transmit array for the point-to-point system, the horizontal slots in each transmit element not being shown for sake of simplicity;

Figure 14 is a side view of the transmit element of the array shown in Figure 13 and depicting a corporate feed network for the element;

30 Figure 15 is a front, perspective view of one of the transmit elements employed in the transmit array of Figure 13;

Figure 16 is a front view of the receive feed horns for the point-to-point system;

5 Figure 17 is a diagrammatic view showing the relationship between a transmitted wave and a portion of the transmit feed array for the point-to-point system;

Figure 18 is a perspective view of a deployed mobile satellite which forms an alternate embodiment of the present invention;

Figure 19 is similar to Figure 18 but depicts the mobile satellite in its stowed position;

10 Figure 20 is an elevational view of a directly-radiating array antenna forming part of the satellite of Figure 18;

Figure 21 is a view similar to Figure 5 but depicting zones covered by the satellite of Figure 18;

15 Figure 22 is an illustration similar to Figure 9A, but showing the antenna pattern contours for three zones;

Figure 23 is a diagrammatic view showing a beam-forming network designed for a system which reuses the frequency spectrum three times;

20 Figure 24 is similar to Figure 6, but illustrates a block diagram for the alternate embodiment;

Figure 25 is a diagrammatic view of an equal power dual amplifier and the resulting power distribution;

Figure 26 is a perspective view of another deployed satellite which forms a further embodiment of the present invention;

Figure 27 is a view similar to Figure 5 and Figure 21, but depicting alternate receive zones;

Figure 28 is an alternate illustration, similar to Figure 9A and Figure 22, of the receive beam patterns;

5                   Figure 29 is similar to Figure 9 illustrating alternate transmit zones;

Figure 30 is an illustration of the transmit beam pattern corresponding to the transmit zones in Figure 29;

10                   Figure 31 is a reference table similar to that shown in Figure 8, but for a filter interconnection matrix for the mobile satellite system depicted in Figure 26; and

Figure 32 is a block diagram of the repeater employed in the satellite shown in Figure 26.

#### DESCRIPTION OF THE PREFERRED EMBODIMENTS

15                   Referring first to Figures 1-4, a communications satellite 10 is depicted which is placed in geosynchronous orbit above the earth's surface. The satellite's antenna system, which will be described in more detail below, will typically be mounted on an earth-oriented platform so that the antenna system maintains a constant orientation with respect to the earth.

20                   The satellite 10 is of a hybrid communications-type satellite which provides two different types of communication services in a particular frequency band, for example, the fixed satellite service Ku band. One type of communication service, referred to hereinafter as point-to-point service, provides two-way communications between very small aperture antenna  
25                   terminals of relatively narrow band voice and data signals. Through the use of frequency division multiple access (FDMA) and reuse of the assigned frequency spectrum, tens of thousands of such communication channels are

5 accommodated simultaneously on a single linear polarization. The other type of communication service provided by the satellite 10 is a broadcast service, and it is carried on the other linear polarization. The broadcast service is primarily used for one-way distribution of video and data throughout the geographic territory served by the satellite 10. As such, the transmit antenna beam covers the entire geographic territory. For illustrative purposes throughout this description, it will be assumed that the geographic area to be serviced by both the point-to-point and broadcast services will be the United States. Accordingly, the broadcast service will be referred to hereinafter as  
10 CONUS (Continental United States).

15 The antenna system of the satellite 10 includes a conventional omni antenna 13 and two antenna subsystems for respectively servicing the point-to-point and CONUS systems. The point-to-point antenna subsystem provides a two-way communication link to interconnect earth stations for two-way communications. The CONUS antenna system functions as a transponder to broadcast, over a wide pattern covering the entire United States, signals received by one or more particular locations on earth. The point-to-point transmit signal and the CONUS receive signal are vertically polarized. The CONUS transmit and point-to-point receive signals are horizontally polarized. The antenna system includes a large reflector assembly 12 comprising two reflectors 12a, 12b. The two reflectors 12a, 12b are rotated relative to each other about a common axis and intersect at their midpoints. The reflector 12a is horizontally polarized and operates with horizontally polarized signals, while the reflector 12b is vertically polarized and therefore operates with vertically polarized signals. Consequently, each  
20 of the reflectors 12a, 12b reflects signals which the other reflector 12a, 12b transmits.  
25

30 A frequency selective screen 18 is provided which includes two halves or sections 18a, 18b and is mounted on a support 30 such that the screen halves 18a, 18b are disposed on opposite sides of a centerline passing diametrically through the satellite 10, as best seen in Figure 2. The frequency selective screen 18 functions as a diplexer for separating different bands of frequencies and may comprise an array of discrete, electrically conductive

elements formed of any suitable material, such as copper. Any of various types of known frequency selective screens may be employed in this antenna system. However, one suitable frequency selective screen, exhibiting sharp transition characteristics and capable of separating two frequency bands which are relatively close to each other, is described in U.S. Patent 4819227.

The frequency selective screen 18 effectively separates the transmitted and received signals for both the CONUS and point-to-point subsystems. It may be appreciated that the two halves 18a, 18b of the screen 18 are respectively adapted to separate individual signals which are horizontally and vertically polarized.

The CONUS subsystem, which serves the entire country with a single beam, has, in this example, eight conventional transponders each having a high power traveling wave tube amplifier as its transmitter 82 (see Figure 6). The CONUS receive antenna uses vertical polarization, sharing the vertically polarized reflector 12b with the point-to-point transmission system. CONUS receive signals pass through the frequency selective screen half 18b and are focused on the receive feed horns 14 located at the focal plane 28 of reflector 12b. The antenna pattern so formed is shaped to cover CONUS. The CONUS transmit antenna employs horizontal polarization, and shares reflector 12a with the point-to-point receive system. Signals radiating from the transmit feeds 24 are reflected by the horizontally polarized frequency selective screen 18a to reflector 12a whose secondary pattern is shaped to cover CONUS.

The point-to-point subsystem broadly includes a transmit array 20, a subreflector 22, and receive feed horns 16. The transmit array 20, which will be described later in more detail, is mounted on the support 30, immediately beneath the screen 18. The subreflector 22 is mounted forward of the transmit array 20 and slightly below the screen 18. The signal emanating from the transmit array 20 is reflected by the subreflector 22 onto one half 18b of the screen 18. The subreflector 22 in conjunction with the main reflector 12 functions to effectively magnify and enlarge the pattern of the signal emanating from the transmit array 20. The signal reflected from



the subreflector 22 is, in turn, reflected by one half 18b of the screen 18 onto the large reflector 12b, which in turn reflects the point-to-point signal to the earth. Through this arrangement, the performance of a large aperture phase array is achieved. The receive feed horns 16 are positioned in the focal plane 26 of the reflector 12a. It consists of four main horns 50, 54, 58, 62 and three auxiliary horns 52, 56, 60 as shown in Figure 16.

Referring now also to Figures 13-15, the transmit array 20 comprises a plurality, for example forty, transmit waveguide elements 106 disposed in side-by-side relationship to form an array, as shown in Figure 13. Each of the transmit waveguide elements 106 includes a plurality, for example twenty-six, of horizontal, vertically spaced slots 108 therein which result in the generation of a vertically polarized signal. As shown in Figure 14, the transmit array 20 is fed with a transmit signal by means of a corporate feed network, generally indicated by the numeral 110 which excites the array element in four places 114. The purpose of the corporate feed network 110 is to provide a broadband match to the transmit waveguide element 106. Signals input to the waveguide opening 112 excite the array slots 108 so that the slot excitation is designed to give a flat pattern in the north-south direction.

Attention is now directed to Figure 5 which depicts a generally rectangular beam coverage provided by the horizontally polarized point-to-point receive system. In this particular example, the area serviced by the point-to-point system is the continental United States. The point-to-point receive system comprises four beams R1, R2, R3, R4 respectively emanating from the four uplink zones 32, 34, 36, 38 to the satellite, wherein each of the beams R1-R4 consists of a plurality of individual uplink beams originating from individual sites in each zone 32, 34, 36, 38 and carries an individual signal from that site. The uplink beam signals from the individual sites are arranged into a plurality of channels for each zone. For example, zone 32 may include a plurality, e.g. sixteen 27 MHz channels with each of such channels carrying hundreds of individual beam signals from corresponding uplink sites in zone 32.

The signal strength for each of the four beam pattern contours, respectively designated by numerals 32, 34, 36 and 38, are approximately 3 dB down from peaks of their respective beams. The antenna beams have been designed to achieve sufficient isolation between them to make feasible in the cross-hatched regions 39, 41, 43, 45 reuse of the frequency spectrum four times. In the dotted regions 40, 42, and 44, the isolation is insufficient to distinguish between signals of the same frequency originating in adjacent zones. Each signal originating in these regions will generate two downlink signals, one intended and one extraneous. The generation of extraneous signals in these areas will be discussed later in more detail.

It may be readily appreciated from Figure 5 that the four zones covered by beams 32, 34, 36, 38 are unequal in width. The East Coast zone covered by beam 32 extends approximately 1.2 degrees; the Central zone covered by beam 34 extends approximately 1.2 degrees; the Midwest zone covered by beam pattern 36 extends approximately 2.0 degrees, and; the West Coast zone covered by beam pattern 38 extends approximately 2.0 degrees. The width of each of the four receive zones 32, 34, 36 and 38 is determined by the number of terminals and thus the population density in the various regions of the country. Thus, beam pattern 32 is relatively narrow to accommodate the relatively high population density in the Eastern part of the United States while beam pattern 36 is relatively wide due to the relatively low population density in the Mountain states. Since each zone utilizes the entire frequency spectrum, zone widths are narrower in regions where the population density is high, to accommodate the greater demand for channel usage.

As shown in Figure 9, the point-to-point transmit system comprises four beams T1, T2, T3, T4 respectively covering the four transmit zones 31, 33, 35, 37, wherein each of the beams T1-T4 consists of a plurality of individual downlink beams destined for the individual downlink sites in each zone 31, 33, 35, 37 and carries an individual signal to that site. The downlink beam signals, destined to be received at the individual downlink sites, are arranged into a plurality of channels for each zone. For example, zone 31 may include a plurality, e.g. sixteen 27 MHz channels with each of such



channels carrying hundreds of individual beam signals to corresponding downlink sites in zone 32.

5           The use of multiple downlink zones and downlink zones of unequal widths assist in causing the intermodulation products, generated by the later-discussed solid state power amplifiers, to be geographically dispersed in a manner which prevents most of these products from being received at the ground terminals. The net effect is that the amplifiers may be operated more efficiently because the system can tolerate more intermodulation products. Although the widths of the transmit zones 31, 33, 35, 37 are nearly the same as those of the receive zones R1, R2, R3, R4, small differences between the two sets have been found to optimize the capacity of the system.

10

15           The half power beam width of the individual transmit beams 29 is substantially narrower than that of the transmit zones 31, 33, 35, 37. This results in the desirable high gain, and avoids the zones of contention 40, 42, 44 characteristic of the receive zone arrangement. These individual beams 29 must be steered within the zones in order to maximize the downlink EIRP in the directions of the individual destination terminals. The transmit point-to-point frequency addressable narrow beams 29 are generated by an array 20 whose apparent size is magnified by two confocal parabolas comprising a main reflector 12b and a subreflector 22. The east-west direction of each beam 29 is determined by the phase progression of its signal along the array 106 of transmit elements 20 (Figures 13 and 15). This phase progression is established by a later-discussed beam-forming network 98 and is a function of the signal frequency. Each of the transmit array elements 20 is driven by a later-discussed solid state power amplifier. The power delivered to the array elements 106 is not uniform but is instead tapered with the edge elements being more than 10 dB down. Tapering of the beams 29 is achieved by adjusting the transmit gain according to the position of the transmit array elements 20. The excitation pattern determines the characteristics of the transmit secondary pattern, shown in Figure 9A. Referring to Figure 9, the closest spacing between transmit zones 31, 33, 35, 37 occurs between zones 31 and 33 and is approximately 1.2 degrees. This means that a signal addressed to zone 33 using a particular frequency would interfere

20

25

30

with a signal using the same frequency in zone 31 with its side lobe 1.2 degrees from its beam center. However, the individual transmit gains have been adjusted to provide low side lobe levels, thereby permitting frequency reuse in adjacent zones. Referring to Figure 9A, it is seen that the side lobe level at this angle off beam center is more than 30 dB down, so that such interference will be negligibly small. The same frequency uses in zones 35 and 37 are further removed in angle, hence the side lobe interference in those zones is even smaller.

Figure 9B is an illustration of the transmit beam pattern in the north-south direction. The twenty six slots 108 in each of the transmit waveguide elements 106 are excited in a manner which creates a nearly flat north-south pattern, extending over the covered range of plus and minus 1.4 degrees from the north-south boresight direction.

Both the point-to-point and CONUS systems may utilize the same uplink and downlink frequency bands, with the point-to-point system using horizontal polarization for its uplink polarization, and the CONUS system using vertical polarization, as previously mentioned. For example, both services may, simultaneously, utilize the entire 500 MHz uplink frequency band between 14 and 14.5 GHz, as well as the entire 500 MHz downlink frequency band between 11.7 and 12.2 GHz. Each of the receive zones 32, 34, 36, 38 and transmit zones 31, 33, 35, 37, employing the point-to-point service utilizes the entire frequency spectrum (i.e. 500 MHz). Furthermore, this total frequency spectrum is divided into a plurality of channels, for example, sixteen channels each having a usable bandwidth of 27 MHz and a spacing of 30 MHz. In turn, each of the sixteen channels may accommodate approximately 800 subchannels. Hence, within each zone, approximately 12,500 (16 channels x 800 subchannels) 32 kilobit per second channels may be accommodated, at any given moment. As will be discussed below, the communication architecture of the point-to-point system allows any terminal to communicate directly with any other terminal. Thus, within a single polarization, a total of 50,000 subchannels may be accommodated nationwide.

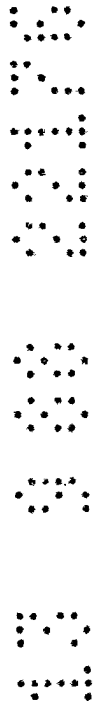

Referring now particularly to Figures 1, 2, 6, 7 and 16, the point-to-point receive feed array 16 employs seven receive horns 50-62. Horns 50, 54, 58 and 62 respectively receive signals from zones 32, 34, 36 and 38. Horns 52, 56 and 60 receive signals from the zones of contention 40, 42 and 44. Using a series of hybrid couplers or power dividers  $C_1$ - $C_9$ , the signals received by horns 50-62 are combined into four outputs 64-70. For example, a signal originating from the area of contention 44 and received by horn 60 is divided by coupler  $C_2$  and portions of the divided signal are respectively delivered to couplers  $C_1$  and coupler  $C_4$  whereby the split signal is combined with the incoming signals received by horns 58, 62 respectively. Similarly, signals originating from the area of contention 42 and received by horn 56 are split by coupler  $C_5$ . A portion of the split signal is combined, by coupler  $C_3$ , with the signal output of coupler  $C_4$ , while the remaining portion of the split signal is combined, by coupler  $C_7$ , with the signal received by horn 54.

Attention is now particularly directed to Figure 6 which depicts, in block diagram form, the electronics for receiving and transmitting signals for both the CONUS and point-to-point systems. The point-to-point receive signals 64-70 (see also Figure 7) are derived from the point-to-point receive feed network in Figure 7, whereas the CONUS receive signal 72 derives from the CONUS receive feed horns 14, (Figures 1 and 3). Both the point-to-point and CONUS receive signal are input to a switching network 76 which selectively connects input lines 64-72 with five corresponding receivers, eight of which receivers are generally indicated at 74. The receivers 74 are of conventional design, three of which are provided for redundancy and are not normally used unless a malfunction in one of the receivers is experienced. In the event of a malfunction, switching network 76 reconnects the appropriate incoming line 64-72 with a back-up receiver 74. Receivers 74 function to drive the filters in a filter interconnection matrix 90. The outputs of the receivers 74, which are connected with lines 64-70, are coupled by a second switching network 78 through four receive lines R1-R4 to a filter interconnection matrix 90. As will be discussed later below, the filter interconnection matrix (FIM) provides interconnections between the receive zones 32, 34, 36, 38, and the transmit zones 31, 33, 35, 37. Operating in the above-mentioned 500 MHz assigned frequency spectrum, separated into sixteen

27 MHz channels, four sets of sixteen filters are employed. Each set of the sixteen filters utilizes the entire 500 MHz frequency spectrum and each filter has a 27 MHz band width. As will be discussed later, the filter outputs T1-T4 are arranged in four groups, each group destined for one of the four transmit zones 31, 33, 35, 37.

The transmit signals T1-T4 are respectively connected, via switching network 94, to four of six driving amplifiers 92, two of such amplifiers 92 being provided for back-up in the event of failure. In the event of the failure of one of the amplifiers 92, one of the back-up amplifiers 92 will be reconnected to the corresponding transmit signal T1-T4 by the switching network 94. A similar switching network 96 couples the amplified output of the amplifiers 92 to a beam-forming network 98. As will be discussed later in more detail, the beam-forming network 98 consists of a plurality of transmission delay lines connected at equal intervals along the four delay lines. These intervals and the width of the delay lines are chosen to provide the desired centerband beam squint and the beam scan rate with frequency for the corresponding transmit zones 31, 33, 35, 37 to be serviced. The transmit signals, coupled from the four delay lines, are summed in the beam-forming network 98 as shown in Figures 11 and 12, to provide inputs to solid state power amplifiers 100, which may be embedded in the point-to-point system's transmit array 20. In the illustrated embodiment discussed below, forty solid state power amplifiers (SSPAs) 100 are provided. Each of the SSPAs 100 amplifies a corresponding one of the forty signals formed by the beam-forming network 98. The SSPAs 100 possess different power capacities to provide the tapered array excitation previously mentioned. The output of the SSPA 100 is connected to the input 112 (Figure 14) at one of the elements of the transmit array 20.

The receive signal for CONUS on line 72 is connected to an appropriate receiver 74 by switching networks 76, 78. The output of the receiver connected with the CONUS signal is delivered to an input multiplexer 80 which provides for eight channels, as mentioned above. The purpose of the input multiplexers 80 is to divide the one low level CONUS signal into subsignals so that the subsignals can be amplified on an individual basis. The

CONUS receive signals are highly amplified so that the CONUS transmit signal may be distributed to very small earth terminals. The outputs of the input multiplexer 80 are connected through a switching network 84 to eight of twelve high power traveling wave tube amplifiers (TWTAs) 82, four of which  
5 TWTAs 82 are employed for back-up in the event of failure. The outputs of the eight TWTAs 82 are connected through another switching network 86 to an output multiplexer 88 which recombines the eight amplified signals to form one CONUS transmit signal. The output of the multiplexer 88 is delivered via waveguide to the transmit horns of the CONUS transmitter 24 (Figures 2 and  
10 3).

Attention is now directed to Figure 10 which depicts the details of the FIM 90 (Figure 6). As previously discussed, the FIM 90 effectively interconnects any terminal in any of the receive zones 32, 34, 36, 38 (Figures 5) with any terminal in any of the transmit zones 31, 33, 35, 37. The  
15 FIM 90 includes four waveguide inputs 120, 122, 124 and 126 for respectively receiving the receive signals R1, R2, R3 and R4. As previously mentioned, receive signals R1-R4, which originate from a corresponding receive zone 32, 34, 36, 38 (Figure 5), each contain the entire assigned frequency spectrum, (e.g. 500 MHz), and are separated into a plurality of channels, (e.g. sixteen 27 MHz channels). The channels are further separated into a plurality of  
20 subchannels, where each of the subchannels carries a signal from a corresponding uplink site. The FIM 90 includes 64 filters, one of which is indicated by the numeral 102. Each of the filters 102 has a passband corresponding to one of the channels (e.g. 1403-1430 MHz). The filters 102 are arranged in four groups, one for each receive zone 32, 34, 36, 38, with each group including two banks or subgroups of eight filters per subgroup. One subgroup of filters 102 contains those filters for the even-numbered channels and the other subgroup in each group contains eight filters for the odd-numbered channels. Thus, for example, the filter group for receive signal R1  
25 comprises subgroup 104 of filters 102 for odd channels, and subgroup 106 of filters 102 for even channels. The following table relates the receive signals and zones to their filter subgroups:

Filter Subgroups

<u>Receive Zone</u>	<u>Receive Signal</u>	<u>Odd Channels</u>	<u>Even Channels</u>	
5	32	R1	104	106
	34	R2	108	110
	36	R3	112	114
	38	R4	116	118

10 The filters are grouped in a unique manner such that when the receive signals R1-R4 are filtered, the filtered outputs are combined to form the transmit signals. The transmit signals T1-T4 also utilize the entire assigned frequency spectrum, (e.g. 500 MHz). In the illustrated embodiment, each of the transmit signals T1-T4 possesses sixteen 27 MHz wide channels, and comprises four channels from each of the four receive zones 32-38 (Figure 5).

15 The incoming receive signals R1-R4 are divided into the corresponding subgroups by respectively associated hybrid couplers 128-134 which effectively divert 50% of the signal power to each subgroup. Hence, for example, one-half of the R1 signal input at waveguide 120 is diverted to transmission line 136 which services the subgroup 104 of filters 102, and the remaining half of the R1 signal is diverted to transmission line 138 which services subgroup 106 of filters 102. In a similar manner, each of the subgroups 104-118 of filters 102 is served by a corresponding distribution line, similar to lines 136 and 138.

20 The construction of subgroup 104 will now be described in more detail, it being understood that the remaining subgroups 106-118 are identical in architecture to subgroup 104. At intervals along the transmission line 136, there are eight ferrite circulators 140, one associated with each of the odd-numbered channel filters 102. The function of the circulators 140 is to connect the transmission line 136 to each of the odd channel filters 102 in a lossless manner. Thus, for example, the R1 signal enters the first circulator 140a and circulates it counterclockwise whereby the 27 MHz band of signals corresponding to channel 1 passes through it to circulator 142. All other

25

30

frequencies are reflected. These reflected signals propagate via the circulator toward the next filter where the process is repeated. Through this process, the R1 receive signal is filtered into sixteen channels by the sixteen filters 104-108 corresponding to the R1 signals. Hence, the R1 signal with frequencies in the range of channel 1 will pass through the first ferrite circulator 140a and it will be filtered by filter 1 of group 104.

The outputs from a filter subgroup 104-118 are selectively coupled by a second set of ferrite circulators 142 which sums, in a criss-cross pattern, the outputs from an adjacent group of filters 102. For example, the outputs of channel filters 1, 5, 9, and 13 of group 104 are summed with the outputs of channel filters 3, 7, 11 and 15 of filter group 112. This sum appears at the output terminal for T1 144. Referring to Figure 8, these signals correspond to the connections between receive zones R1 and R3 and to transmit zone T1.

Attention is now directed to Figures 8 and 9 which depict how the transmit and receive signals are interconnected by the FIM 90 to allow two-way communication between any terminals. Specifically, Figure 8 provides a table showing how the receive and transmit zones are connected together by the interconnect channels while Figure 9 depicts how these interconnect channels are distributed geographically across the transmit zones 31, 33, 35, 37. In Figure 8, the receive signals R1-R4 are read across by rows of interconnect channels and the transmit signals T1-T4 are read by columns of interconnect channels. It can be readily appreciated from Figure 8 that each of the transmit signals T1-T4 is made up of sixteen channels arranged in four groups respectively, where each group is associated with one of the receive signals R1-R4. The satellite communications system of the present invention is intended to be used in conjunction with a ground station referred to as a satellite network control center which coordinates communications between the ground terminals via packet switched signals. The network control center assigns an uplink user with an uplink frequency based on the location of the desired downlink, assigning the available frequency whose downlink longitude is closest to that of the destination. The frequency addressable downlink transmit beams 29 are thus addressable by the

frequencies of the uplink signals. This strategy maximizes the gain of the downlink signal.

5 As shown in Figure 9, the continental United States is divided into four primary zones 31, 33, 35, 37. Zone 31 may be referred to as the East Coast zone, zone 33 is the Central zone, zone 35 is the Mountain zone, and zone 37 is the West Coast zone. As previously mentioned, each of the zones 31, 33, 35, 37 utilizes the entire assigned frequency spectrum (e.g. 500 MHz). Thus, in the case of a 500 MHz assigned frequency band, there exists sixteen 27 MHz channels plus guard bands in each of the zones 31, 33, 35, 37.

10 The numbers 1-16 repeated four times above the beams 29 in Figure 9 indicate the longitude of the beams corresponding to the center frequencies of the channels so numbered. Because of the frequency sensitivity of the beams, the longitude span between the lowest and highest frequency narrow band signal in a channel is approximately one channel width. Each beam is 0.6 degrees wide between its half power point, about half the zone width in the East Coast and Central zones and nearly one-third the zone width in the Mountain and West Coast zones. The antenna beams 29 overlap each other to ensure a high signal density; the more that the beams overlap, the greater channel capacity in a given area. Hence, in the East Coast zone 31, there is a greater overlap than in the Mountain zone 35 because the signal traffic in the East Coast zone 31 is considerably greater than that in the Mountain zone 35.

15  
20  
25  
30 The interconnect scheme described above will now be explained by way of a typical communication between terminals in different zones. In this example, it will be assumed that a caller in Detroit, Michigan wishes to place a call to a terminal in Los Angeles, California. Thus, Detroit, Michigan, which is located in the Central zone 34, is the uplink site, and Los Angeles, California, which is located in the West Coast zone 37, is the downlink destination. As shown in Figure 9, each geographic location in the continental United States can be associated with a specific channel in a specific zone. Thus, Los Angeles is positioned between channels 14 and 15 in transmit zone 37.



Referring now concurrently to Figures 5, 8 and 9 particularly, receive and transmit zones R1 and T1 lie within the East Coast zone 32 and 31, R2 and T2 lie within the Central zone 34 and 33, R3 and T3 lie within the Mountain zone 36 and 35, and R4 and T4 lie within the West Coast zone 38 and 37. Since Detroit lies in the Central or R2 zone 34, it can be seen that the only channels over which signals can be transmitted to the West Coast or T4 zone 37 are channels 1, 5, 9 and 13. This is determined in the table of Figure 8 by the intersection of row R2 and column T4. Therefore, from Detroit, the uplink user would uplink on either channel 1, 5, 9 or 13, whichever of these channels is closest to the downlink destination. Since Los Angeles is located between channels 14 and 15, the network control center would uplink the signal on channel 13 because channel 13 is the closest to channel 14. The downlink beam width is broad enough to provide high gain at Los Angeles.

Conversely, if the uplink site is in Los Angeles and the downlink destination is in Detroit, the intersection of row R4 and column T2 in Figure 8 must be consulted. This intersection reveals that the signal can be transmitted on channels 1, 5, 9 or 13 depending upon which channel is closest to the downlink destination. The network control center would uplink the signal from Los Angeles on channel 9 since channel 9 is closest to channel 11 which, in turn, is closest to Detroit.

Returning now to Figure 10, the conversion of a receive signal to a transmit signal will be described in connection with the example mentioned above in which the uplink site is in Detroit and the downlink site is in Los Angeles. The uplink signal transmitted from Detroit would be transmitted on channel 13 carried by receive signal R2. Thus, the R2 receive signal is input to transmission line 122 and a portion of such input signal is diverted by the hybrid coupler 130 to the input line of subgroup 108 of filters 102. Subgroup 108 includes a bank of eight filters for the odd channels, including channel 13. Thus, the incoming signal is filtered through by filter 13 and is output on a line 164 along with other signals from subgroups 108 and 116. The channel 13 signal present on line 164, is combined by the hybrid coupler 158, with signals emanating from subgroup 106 and 114, and forms the

T4 signal on output line 150. The transmit signal T4 is then downlinked to Los Angeles.

5 It is to be understood that the above example is somewhat simplified inasmuch as the network control center would assign a more specific channel than a 27 MHz wide band channel, since the 27 MHz wide channel may actually comprise a multiplicity of smaller channels, for example, 800 subchannels of 32 KHz bandwidth.

10 Referring now again to Figures 5, 8 and 9, in the event that an uplink signal originates from one of the areas of contention, 40, 42, 44 (Figure 5), such signal will not only be transmitted to its desired downlink destination, but a non-negligible signal will be transmitted to another geographic area. For example, assume that the uplink signal originates from Chicago, Illinois which is in the area of contention 42 and that the signal is destined for Los Angeles, California. The area of contention 42 is produced by the overlap of the beams forming zones 34 and 36. Hence, the uplink signal can be transmitted as receive signals R2 or R3. The network control center determines whether the uplink communication is carried by receive signals R2 or R3. In the present example, since Chicago is closer to zone 36, the uplink communication is carried on receive signal R3.

20 As previously discussed, the downlink destination, Los Angeles, is located in zone 37 and lies between channels 14 and 15. As shown in Figure 8, the intersection of R3 with column T4 yields the possible channels over which the communication can be routed. Thus, the Chicago uplink signal will be transmitted over one of channels 2, 6, 10 or 14. Since Los Angeles is closest to channel 14, channel 14 is selected by the network control center as the uplink channel. Note, however, that an undesired signal is also transmitted from zone 34 on channel 14. To determine where the undesired signal will be downlinked, the table of Figure 8 is consulted. The table of Figure 8 reveals that uplink signals carried on channel 14 in the R2 zone 34 are  
25  
30 downlinked to the T1 transmit zone 31. The desired signal is transmitted to Los Angeles and the undesired signal (i.e. an extraneous signal) is transmitted to the East Coast (i.e. zone 31). The network control center keeps track of

these extraneous signals when making frequency assignments. The effect of these extraneous signals is to reduce slightly the capacity of the system.

Referring now again to Figure 6, the beam-forming network 98 receives the transmit signals T1-T4 and functions to couple all of the individual communication signals in these transmit signals together so that a transmit antenna beam for each signal is formed. In the example discussed above in which the assigned frequency spectrum is 500 MHz, a total of approximately 50,000 overlapping antenna beams are formed by the beam-forming network 98 when the system is fully loaded with narrow band signals. Each antenna beam is formed in a manner so that it can be pointed in a direction which optimizes the performance of the system. The incremental phase shift between adjacent elements determines the direction of the antenna beam. Since this phase shift is determined by the signal frequency, the system is referred to as frequency addressed.

Attention is now directed to Figures 11 and 12 which depict the details of the beam-forming network 98. The beam-forming network, generally indicated by the numeral 98 in Figure 11, is arranged in the general form of an arc and may be conveniently mounted on the communication shelf (not shown) of the satellite. The arc shape of the beam-forming network 98 facilitates an arrangement which assures that the paths of the signals passing therethrough are of correct length.

The beam-forming network 98 includes a first set of circumferentially extending transmission delay lines 168, 170, a second set of transmission delay lines 172, 174 which are radially spaced from delay lines 168 and 170, and a plurality of radially extending waveguide assemblies 176. In the illustrated embodiment, forty waveguide assemblies 176 are provided, one for each of the elements 106 of the transmit array 20 (Figure 13). The waveguide assemblies 176 intersect each of the delay lines 168-174 and are equally spaced in angle.

Each of the waveguide assemblies 176 defines a radial line summer and intersects each of the delay lines 168-174. As shown in Figure 12, at the points of intersection, between the radial line summers 176 and the transmission delay lines 168-174, a crossguide coupler 180 is provided. The crossguide coupler 180 connects the delay lines 168-174 with the radial line summers 176. The function of the crossguide couplers 180 will be discussed later in more detail.

Four delay lines 168-174 are provided respectively for the four transmit zones T1-T4 (Figure 9). Hence, transmit signal T1 is provided to the input of delay line 170, T2 is provided to input of delay line 168, T3 is provided to the input of delay line 174, and T4 is provided to the input of delay line 172. As shown in Figure 12, the distance between the radial line summers is indicated by the letter "l" and the width of each of the radial delay lines is designated by the letter "w". Although the radial line summers 176 are spaced at equal angular intervals along the delay lines 168-174, the distance between them varies from delay line to delay line due to the fact that the delay lines 168-174 are radially spaced from each other. Thus, the further from the center of the arc, which is formed by the radial line summers 176, the greater the distance between the radial line summers 176, at the point where they intersect with the delay lines 168-174. In other words, the spacing "l" between adjacent radial line summers 176 for delay line 168 is less than the spacing between adjacent radial line summers 176 than for delay line 174. Typical values for the dimensions "l" and "w" are as follows:

	<u>Delay Line</u>	<u>Signal</u>	<u>l. inches</u>	<u>w. inches</u>
25	168	T2	1.66	0.64
	170	T1	1.72	0.66
	172	T4	2.45	0.74
	174	T3	2.55	0.76

The width of the delay lines 168-174, "w", and the distance "l" between adjacent radial line summers are chosen to provide the desired center beam squint and beam scan rate so that the beam pointing is correct for each channel. This results in the desired start and stop points for each of the transmit zones T1-T4.

Referring particularly to Figure 12, the transmit signal T2 propagates down the delay line 168 for a precise distance, at which point it reaches the first radial line summer 176. A portion of the T2 signal passes through the crossguide coupler 180, which may, for example, be a 20 dB coupler, such that one percent of the transmitted power of transmit signal T2 is diverted down the radial line summer 176. This diverted energy then propagates down the waveguide 176 towards a corresponding solid state power amplifier 100 (Figures 6 and 11). This process is repeated for signal T1 which propagates down delay line 170. The portions of signals T1 and T2 which are diverted by the crossguide couplers 180 (i.e. 0.01 T1 and 0.01 T2) are summed together in the radial line summer 176 and the combined signal 0.01 (T1 + T2) propagates radially outwardly toward the next set of delay lines 172, 174. This same coupling process is repeated for signals T3 and T4 in delay lines 174 and 172 respectively. That is, 0.01 of signals T3 and T4 are coupled via crossguide couplers 180 to the radial line summer 176. The resulting combined signal 0.01 (T1 + T2 + T3 + T4) propagates radially outwardly to an associated solid state power amplifier 100 where it is amplified in preparation for transmission.

After encountering the first radial line summer 176, the remaining 0.99 of signals T1-T4 propagate to the second radial line summer where an additional one percent of the signals is diverted to the summer 176. This process of diverting one percent of the signals T1-T4 is repeated for each of the radial line summers 176.

The signals, propagating through the radial line summers 176 towards the SSPAs 100, are a mixture of all four point-to-point transmit signals T1-T4. However, each of the transmit signals T1-T4 may comprise 12,500 subsignals. Consequently, the forty signals propagating through the

radial line summers 176 may be a mixture of all 50,000 signals in the case of the embodiment mentioned above where the assigned frequency spectrum is 500 MHz wide. Therefore, each of the SSPAs 100 amplifies all 50,000 signals which emanate from each of the plurality of wave guide assemblies 176.

5                    Since each of the SSPAs 100 amplifies all 50,000 signals which are destined for all regions of the country, it can be appreciated that all of the narrow, high gain downlink beams are formed from a common pool of transmitters, i.e. all of the SSPAs 100. This arrangement may be thought of as effectively providing a nationwide pool of power since each of the downlink  
10 beams covering the entire country is produced using all of the SSPAs 100. Consequently, it is possible to divert a portion of this nationwide pool of power to accommodate specific, disadvantaged downlink users on an individual basis without materially reducing the signal power of the other beams. For example, a downlink user may be "disadvantaged" by rain in the  
15 downlink destination which attenuates the signal strength of the beam. Such a rain disadvantaged user may be individually accommodated by increasing the signal strength of the corresponding uplink beam. This is accomplished by diverting to the disadvantaged downlink beam, a small portion of the power from the pool of nationwide transmitter power (i.e. a fraction of the power  
20 supplied by all of the SSPAs 100). The power of an individual uplink beam is proportional to that of the corresponding downlink beam. Consequently, in order to increase the power of the downlink beam it is merely necessary to increase the power of the uplink beam.

                    In practice, the previously mentioned network control  
25 center keeps track of all of those regions of the country in which it is raining and determines which of the uplink users are placing communications to downlink destinations in rain affected areas. The network control center then instructs each of these uplink users, using packet switched signals, to increase its uplink power for those signals destined for a rain affected area.  
30 The increase in power of the uplink user's signals results in greater collective amplification of these signals by the SSPAs 100, to produce corresponding downlink beams to the rain affected areas, which have power levels increased sufficiently to compensate for rain attenuation. Typically, the number of

signals destined for rain affected areas is small relative to the total number of signals being handled by the total pool of SSPAs 100. Accordingly, other downlink users not in the rain affected zones do not suffer substantial signal loss since the small loss that may occur in their signals is spread out over the many thousand users.

5

The SSPAs 100 (Figures 8 and 11) may be mounted, for example, on the rim of the communication shelf (not shown) of the satellite. The signals amplified by the SSPAs 100 are fed into the corresponding elements 106 of the transmit array 20 (Figure 13 and 14).

10

As previously discussed, an incremental phase shift is achieved between the signals that are coupled in the forty radial line summers 176. Hence, the beam-forming network 98 permits the antenna beams emanating from the transmit array 20 (Figures 1, 2, and 13) to be steered by frequency assignment. The incremental phase shift is related to the time delay between the waveguides 176 as well as frequency. Attention is now directed to Figure 17 which is a diagrammatic view of four of the forty transmit array elements 106 (Figure 13), showing the wavefront emanating therefrom, wherein "d" is equal to the spacing between transmit array elements 106. The resulting antenna beam has an angular tilt of  $\theta$ , where  $\theta$  is defined as the beam scan angle. This means that  $\theta$  is the angle from normal of the transmit beam center. The incremental phase shift produced by the delay line arrangement is  $\Delta\phi$ . The relationship between  $\Delta\phi$  and  $\theta$  is given by

15

20

$$\Delta\phi = \frac{2\pi d}{\lambda} \sin \theta$$

25

where:

$\lambda$  = signal wavelength

$\theta$  = beam scan angle

d = spacing between array elements

Hence, the east-west direction of the antenna beam is determined by the incremental phase shift which is different for the four delay lines 168-174 of the beam-forming network 98, resulting in the four transmit zones T1-T4 previously noted.

5                   Reference is now made to Figures 18 and 19 wherein still  
another alternate form of the invention illustrated in Figures 1-19 is depicted.  
In the alternate embodiment, the satellite 200 employs a direct radiating array  
antenna 202 for both the reception and transmission and is designed for L  
band and Ku band service. In Figure 18, the satellite 200 is illustrated in its  
10                   deployed position. The satellite 200 is body-stabilized, and has solar panels  
206 and antenna arrays 202, 204 arranged so that they may be stowed, as  
illustrated in Figure 19, in a compact arrangement during launch.  
Specifically, the outer portions of the L band array 202 are hinged so that they  
may be swung inwardly to a stowed position for launch. Similarly, the solar  
15                   panels 206 which occupy the north and south faces of the body-stabilized bus  
are hinged so that they may be stowed compactly for launch and the Ku band  
array 204 is positioned so that it facilitates stowing of the satellite during  
launch. Referring now also to Figure 20, the L band directly radiating array  
antenna 202 is a close-packed, two-dimensional array of circularly-polarized  
20                   cupped dipoles 205. In the illustrated embodiment, the array 202 is 2.4 m by  
8.0 m, and has thirty-two columns, where each column of dipoles is driven in  
pairs 207 so that only sixteen drive points are needed. The array 202 forms  
both transmit and receive beams.

                  Referring to Figure 21 and 22 concurrently, a typical  
25                   geographic area (greater North America) serviced by the satellite 202 is  
illustrated. The satellite system is designed to reuse the L band frequency  
spectrum three times, the frequency band being reused in each zone 206, 208,  
210. In each zone 206, 208, 210, the low end of the frequency band is directed  
to the west edge of the zone, and the high end is directed to the east edge of the  
30                   zone. As illustrated in Figure 22, where the zones 209, 211 meet, the high-  
frequency end of one zone coincides with the low frequency end of the other  
zone. By using a tapered illumination of the array, suitably low side lobe



levels are generated so that the interference caused by the simultaneous use of each frequency channel three times is reduced to acceptable levels.

5 In order to achieve reuse of the frequency spectrum three times, a three-zone beam-forming network 212, as shown in Figure 23, is employed. The beam-forming network 212 functions similar to the previously discussed beam-forming network illustrated in Figure 11. The beam-forming network 212 also includes transmission delay lines 214 wherein there is one delay line associated with each zone 206, 208, 210, and there are three transmission lines 216 for each pair of the sixteen drive points in the array antenna 202. The outputs of the three zonal signals are added by hybrid couplers 218 to form single outputs corresponding to the antenna drive points.

10 Reference is now made to Figure 24, wherein a block diagram of the satellite 200 is shown which is particularly suited for use with mobile ground stations. With mobile service, the mobile users and the stationary parties are connected by base stations.

15 The satellite 200 and the base stations for the fixed terminal service communicates over assigned frequencies in the Ku-band, whereas the satellite 200 and the mobile service users communicate over assigned frequencies in the L band on both the uplink and downlink. Ku-band signals from base stations are received by the Ku array antenna 204 and receivers 257. The signal frequency is converted from Ku-band to L-band by down converters 255. The converted L-band signals from the multiple zones, are combined in a three zone beam-forming network 212, amplified by dual power amplifiers 251, divided by a diplexer 259, and transmitted to mobile service users via the L-band array 202. This is referred to as the "forward communication link". The "return communication link", from the mobile users is transmitted to the satellite 200 over L-band and received by the L-band array 202. The L-band signals from different receive zones, are amplified by amplifier 263, combined by a beam forming network 212, and upconverted 253 to the Ku-band frequency. The signals are transmitted 261 via the Ku-band array 204 to the base stations in various zones.

Reference is now made to Figure 25, wherein the power distribution 252 for the array 202 is shown. In order to avoid the design and production costs associated with systems employing several multiple level power amplifiers, the unequal power levels, required by the array elements 205, are generated by hybrid-coupled dual amplifiers 251. In this arrangement, there are eight hybrid-coupled dual amplifiers wherein all of the amplifiers operate at the same power level despite the unequal power levels at their inputs and outputs. By the use of hybrid-coupled dual amplifiers 251, the intermodulation products are dispersed geographically, thus reducing their level at the user's locations. In addition, by using power amplifiers 251, in which each amplifier contributes to the amplification of all of the signals, maximum flexibility and power assignment is achieved.

Referring to Figure 26, another alternate embodiment of the invention is illustrated wherein the satellite system provides for a private Ku-band network system 250 utilizing four direct-radiating arrays: two receive arrays 235, 236 and two transmit arrays 237, 238. There are two arrays for both the transmit and receive because both the broadcast and point-to-point services are accommodated on a single polarization. One receive array 235 is dedicated for horizontal polarization while the second receive array 236 is dedicated to vertical polarization. Similarly, one transmit array 237 is dedicated for horizontal polarization and the second transmit array 238 is dedicated for the vertical polarization. Both services are made available on one polarization by allocating one half of the frequency spectrum to broadcast service and one half of the spectrum to point-to-point service. By providing both services on one polarization, the aperture of the ground terminals may be small, thus reducing the cost of the ground stations. Two parabolic reflectors 244 are used to provide shaped beam coverage over the geographic region serviced by the satellite. The Ku-band domestic system, like the L band mobile system, is able to overcome rain attenuation on the downlink with only slight penalty to the signals in rain-free areas. Since only a small portion of the country experiences rain at one time, large power increases to those disadvantaged areas causes only a slight decrease in power available elsewhere. As with the L band mobile system, the solar panels 248 are extendable and are stowed during launch.

The illustrated Ku-band satellite system permits frequency reuse in the private network system by utilizing very small aperture earth terminals on user premises. The private network may be either a "star" network, which connects the earth terminals to a central data base and provides broadcast video capacity, or a "mesh" network, which connects the earth terminals by circuit-switched interconnections to provide services such as teleconferencing, high-speed graphics, and voice communication.

Attention is now directed to Figure 27 which illustrates contiguous receive zones 220, 222, 224, 226 for a typical domestic Ku-band private network satellite system. In this system, pairs of users are directly connected without the use of intermediary base stations, thus precluding the use of a frequency addressable beam on both the uplink and downlink. Consequently, a set of frequency independent beams is used on the uplink, so that frequency may be used to address the downlink destination.

There are four receive zones 220, 222, 224, 226 servicing the area because the frequency spectrum is reused on the uplink four times, the entire frequency spectrum being used in each of the zones 220, 222, 224, 226. In order for each uplink zone to be contiguous and non-interfering, each zone is further subdivided into two half zones, illustrated in Figure 27, 220a and 220b, 222a and 222b, 224a and 224b, and 226a and 226b. The receive beam patterns corresponding to zones 220a, 220b, 222a, 222b, 224a, 224b, 226a, and 226b are illustrated in Figure 28. Figure 28 shows the center frequency for each receive beam. The beam patterns 221, 223, 225, 227, 229, 231, 233 may be generated, for example by an array 80 wavelengths wide driven at 16 drive points through a Butler matrix having 16 antenna terminals and providing 8 beam outputs. The beam patterns 221, 223, 225, 227, 229, 231, 233, 235 have sufficient spatial isolation to permit frequency reuse among the beams separated by at least one beam but not among adjacent beams. The satellite uses four two-position time switches so that the "a" and "b" beams are used alternately; this is effectively a type of time division arrangement. The switches, operating at the low speed of, for example, 50 Hz, provide four receive zone outputs to the four receivers that amplify and convert the signals

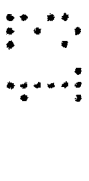
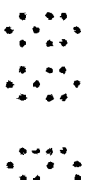

from 14 to 12 GHz. Using a 50 Hz switch and creating a 20 msec period means that during one time period while the "a" frequencies are simultaneously used in the four zones, the "b" set of frequencies are not "on" and thus are not used. Hence, the "a" and "b" frequencies will not interfere with one another. Since the duty cycle is one half, the power requirement is doubled at each terminal.

Referring also to Figures 29 and 30, the transmit zones and the transmit beam patterns are respectively shown. The transmit zones 228, 230, 232, 234 illustrated in Figure 29 are essentially the same as the receive zones 220, 222, 224, 226 illustrated in Figure 27. The transmit zone 228 corresponds to the receive zone 220, transmit zone 230 corresponds to receive zone 222, transmit zone 232 corresponds to the receive zone 224, and transmit zone 234 corresponds to receive zone 226. As with the uplink, the downlink spectrum is also reused four times, the entire spectrum being reused in each of the transmit zones 228, 230, 232, 234. As shown in Figure 30, each of the transmit beams 237, 239, 241, 243 respectively correspond to the transmit zones 228, 230, 232, 234.

Referring to Figure 31, a filter interconnect matrix 252 is shown which includes an assembly of thirty-six filters that provides the connections between the receive zones 220a, 220b, 222a, 222b, 224a, 224b, 226a, 226b (R1 A, R1 B, R2 A, R2 B, R3 A, R3 B, R4 A, R4 B) and transmit zones 228, 230, 232, 234 (T1, T2, T3, T4). The filter interconnection matrix 252 is similar to the previously discussed filter matrix 90. The rows of the matrix are driven by the receiver outputs, and the preselected groups of output from nine filters are directed to the four transmit zones T1, T2, T3, T4.

Referring to Figure 32, a block diagram of the alternate embodiment of the present invention is illustrated. Signals received by the receive array antenna 236 enter a beam forming network 265, similar to the previously discussed BFN 98 and 212 to combine the received signals. The combined signals are routed to receivers 269 by time division switches 267 where the signals are preselectively filtered by a filter interconnection matrix 252 which performs in substantially the same manner as the previously discussed FIM 90. The filtered signals to be transmitted are also combined in



THE CLAIMS DEFINING THE INVENTION ARE AS FOLLOWS:

1. A method of communicatively interconnecting any of a plurality of terminals within an area on the earth using an earth-orbiting communications satellite, comprising the steps of:

(A) forming a first plurality of groups of radio frequency beams respectively between each of a plurality of essentially contiguous zones covering said area on the earth and said satellite, the beams in said groups thereof carrying communications signals over the same first preselected range of frequencies, such that said first preselected range of frequencies is reused by the beams of all of said zones;

(B) separating each group of said radio frequency beams into first and second sets thereof respectively carrying communications signals over first and second sets of frequencies within said first preselected range of frequencies, and spatially distributing said first preselected range of frequencies over each of the zones as a function of frequency such that the frequencies of one set of said beams in one zone is spatially separated from the frequencies of one set of said beams in a zone substantially contiguous to said one zone;

(C) alternately transmitting the first and second sets of said beams between said zones and said satellite by simultaneously transmitting the beams in the first set thereof for all the zones and then simultaneously

7717S/NL



transmitting the beams in the second set thereof for all the zones.

2. The method of claim 1, wherein step (B) is  
5 performed by spatially distributing the first preselected range of said frequencies over each zone such that contiguous sections of the area serviced by the beams in adjacent zones are respectively covered by different sets of said beams to avoid communication interference in the  
10 areas serviced by the beams in said adjacent zones.

3. The method of claim 2, wherein step (C) is  
performed by simultaneously transmitting the beams in the first set thereof for all the zones and then  
15 simultaneously transmitting the beams in the second set thereof for all the zones.

4. The method of claim 1, wherein step (C) is  
performed by transmitting the first and second sets of  
20 beams from each of said zones to said satellite.

5. The method of claim 4, including the steps of:  
(D) receiving said first and second sets of beams at said satellite; and  
25 (E) transmitting a second plurality of groups of radio frequency beams respectively from said satellite to said zones, the beams in each group of said second plurality thereof carrying communications signals over the same second preselected range of frequencies, whereby said



second preselected range of frequencies is reused by all of the groups of beams in said second plurality thereof.

6. The method of claim 5, wherein step (E) is performed by spatially distributing the beams in each of said second plurality of groups thereof across the corresponding zone as a function of said second preselected range of frequencies.

7. The method of claim 5, wherein the sets of frequencies of said contiguous two sections are different from each other, whereby to avoid communications interference between said contiguous two sections.

8. The method of claim 7, including the step of forming said first and second beams for each of said zones such that said first and second beam for each of said zones collectively define a rectangularly shaped area of communications service on the earth which corresponds to the associated zone.

25



7717S/NL



1           9.       The method of claim 8, wherein the rectangularly shaped  
areas of communications service are essentially contiguous.

1           10.       The method of claim 7, wherein at least two of the sections  
of respective contiguous zones are contiguous to each other, and the sets of  
frequencies of said contiguous two sections are different from each other,  
whereby to avoid communications interference between said contiguous two  
5 sections.

1           11.       The method of claim 7, including the steps of:  
              (D)       receiving said first and second beams at said  
satellite; and  
              (E)       transmitting to each of said zones a plurality of  
5 downlink radio beams, each plurality of said downlink beams carrying  
communications signals over the same, second preselected range of  
frequencies, whereby said second preselected range of frequencies is reused by  
the downlink beams for all of said zones.

1           12.       The method of claim 11, wherein step (E) includes the step of  
spatially disbursing the downlink beams in each plurality thereof as a  
function of frequency,

              13.       A method of communicatively interconnecting any one  
of a plurality of terminals within an area on the earth using an  
earth orbiting communication satellite substantially as hereinbefore  
described with any one embodiment as shown in the accompanying  
drawings.

Dated this 18th day of October 1990.

HUGHES AIRCRAFT COMPANY  
By their Patent Attorney  
GRIFFITH HACK & CO.



22 176/88

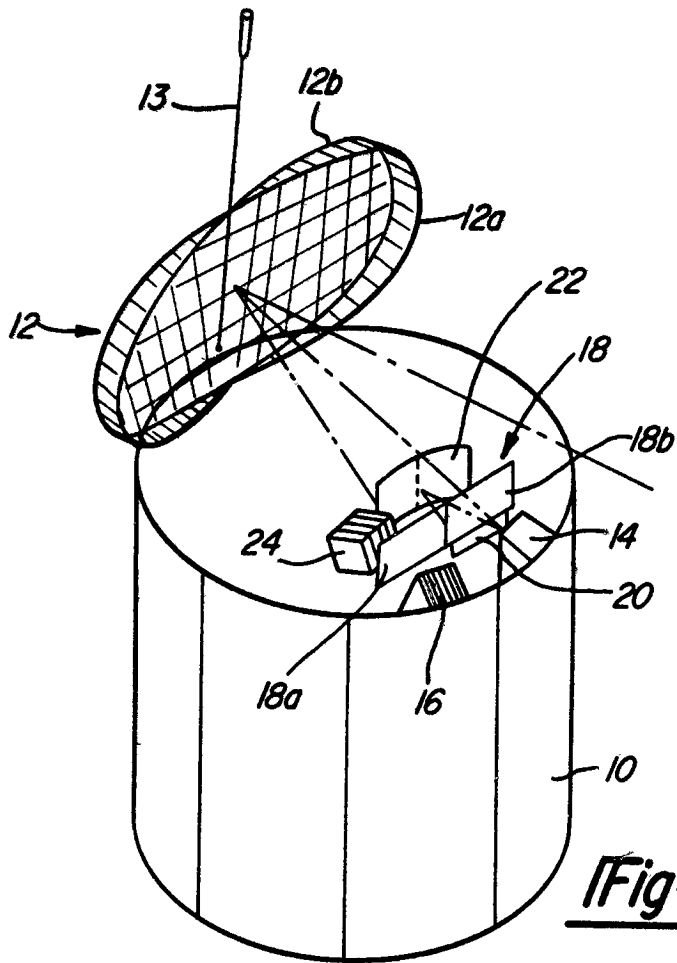

Fig-1

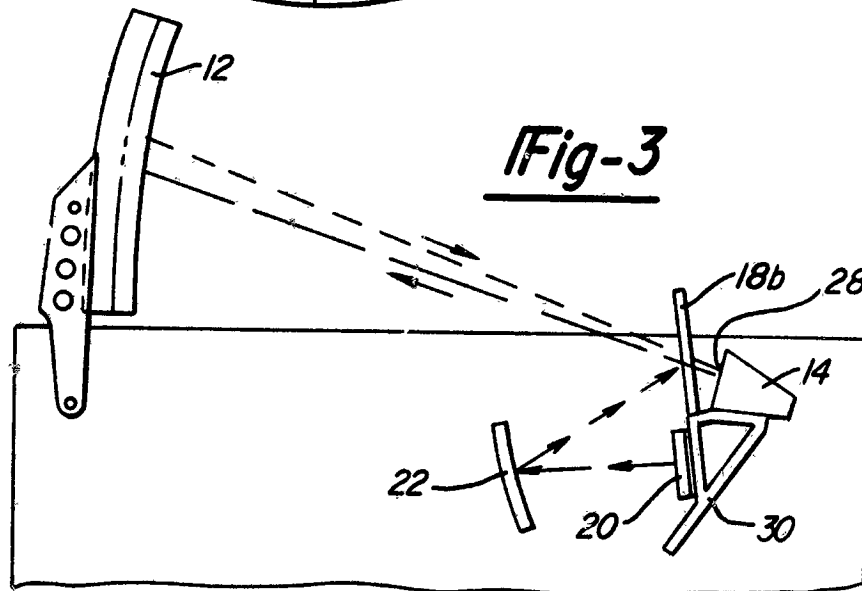
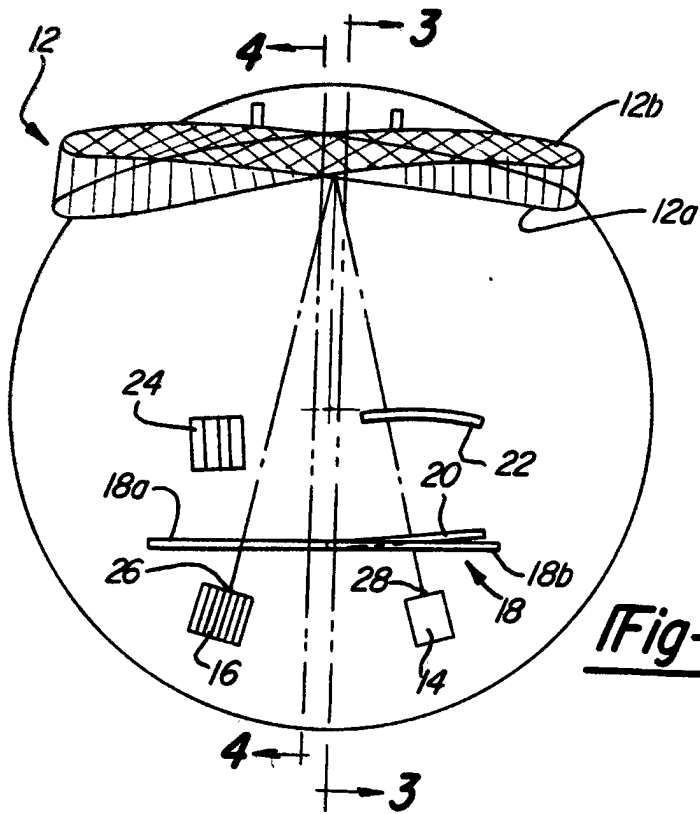
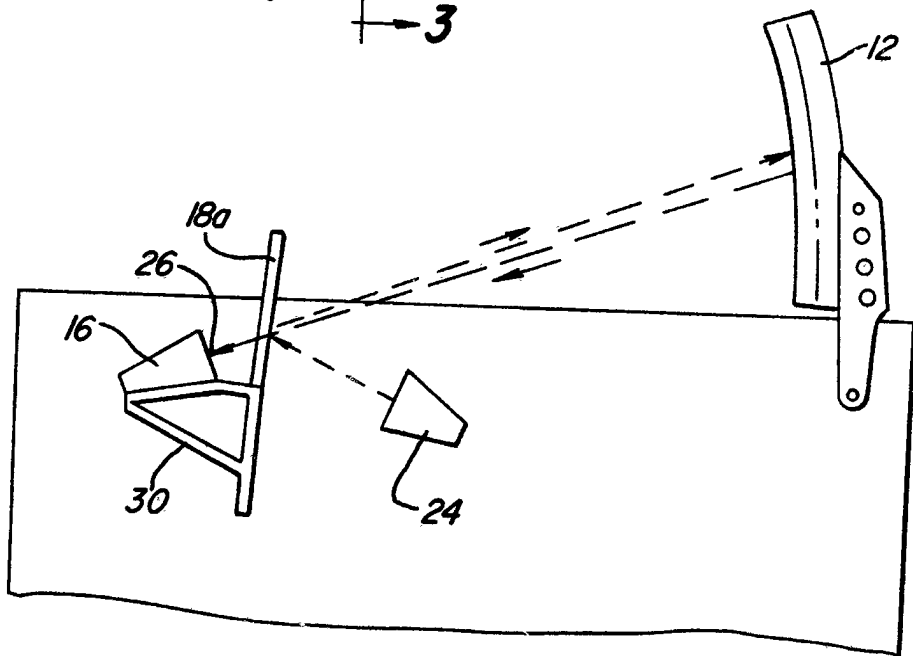

Fig-3

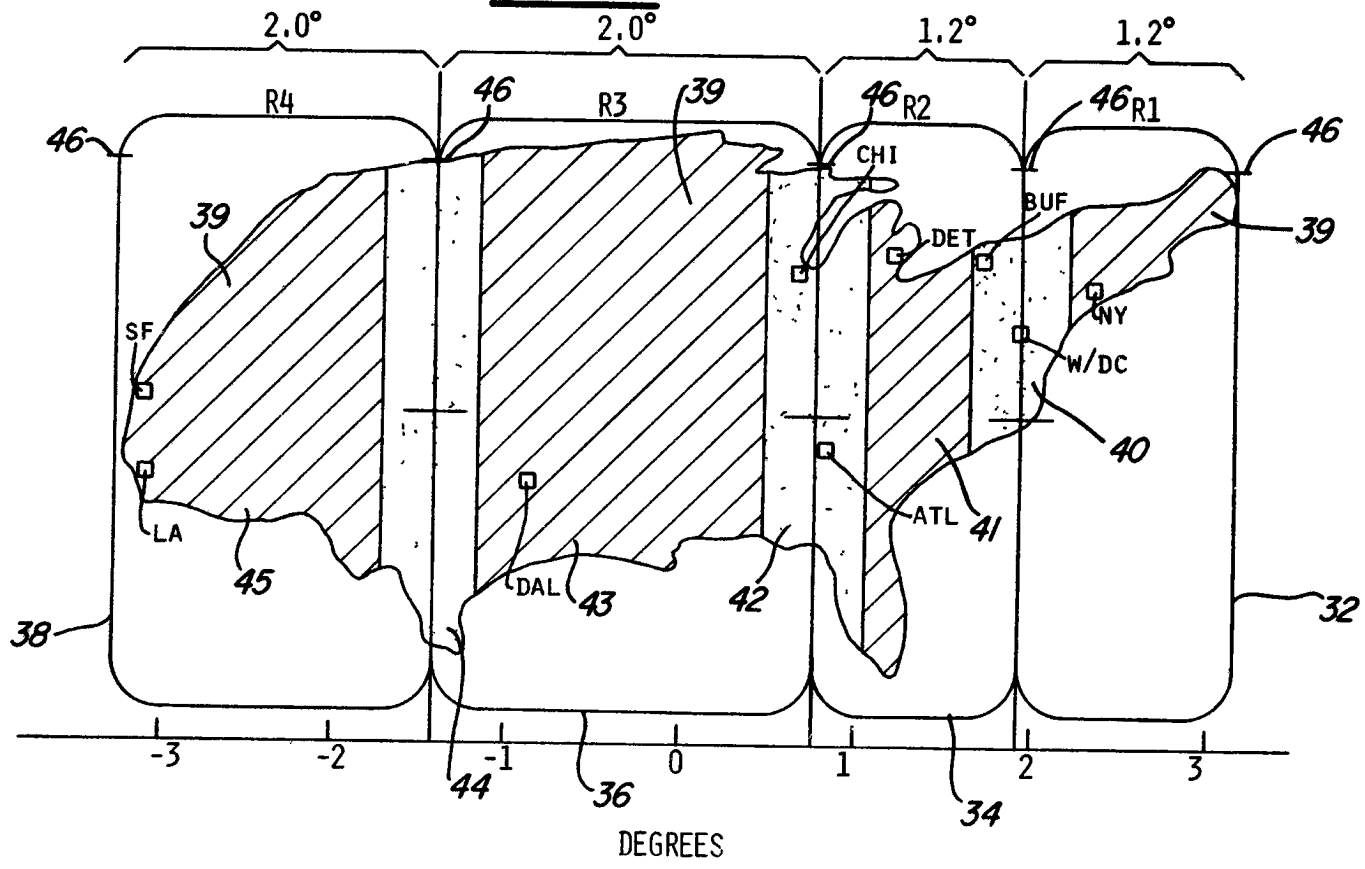

**Fig-2**



**Fig-4**

Fig-5



SECRET

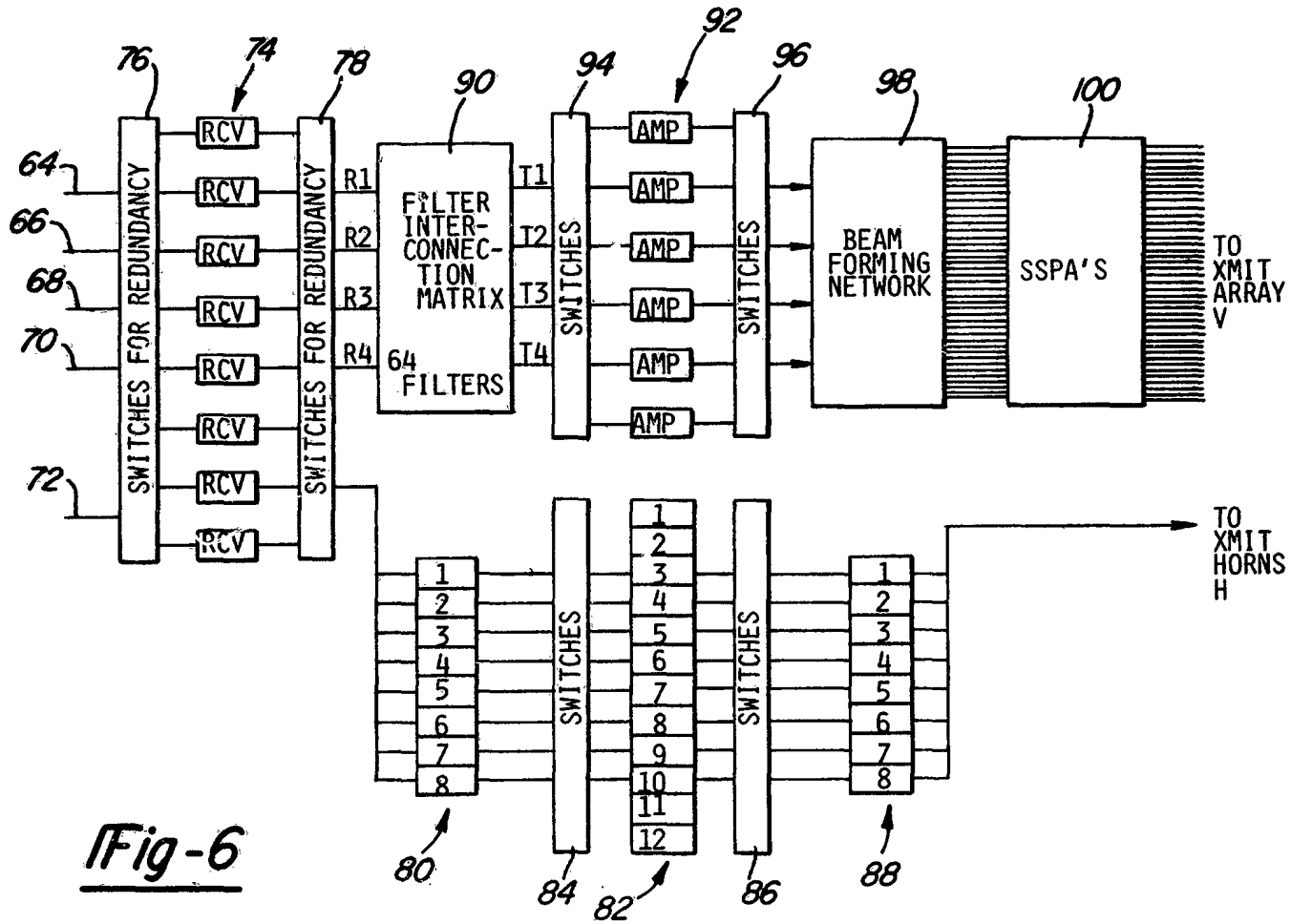

Fig-6

22 176/88

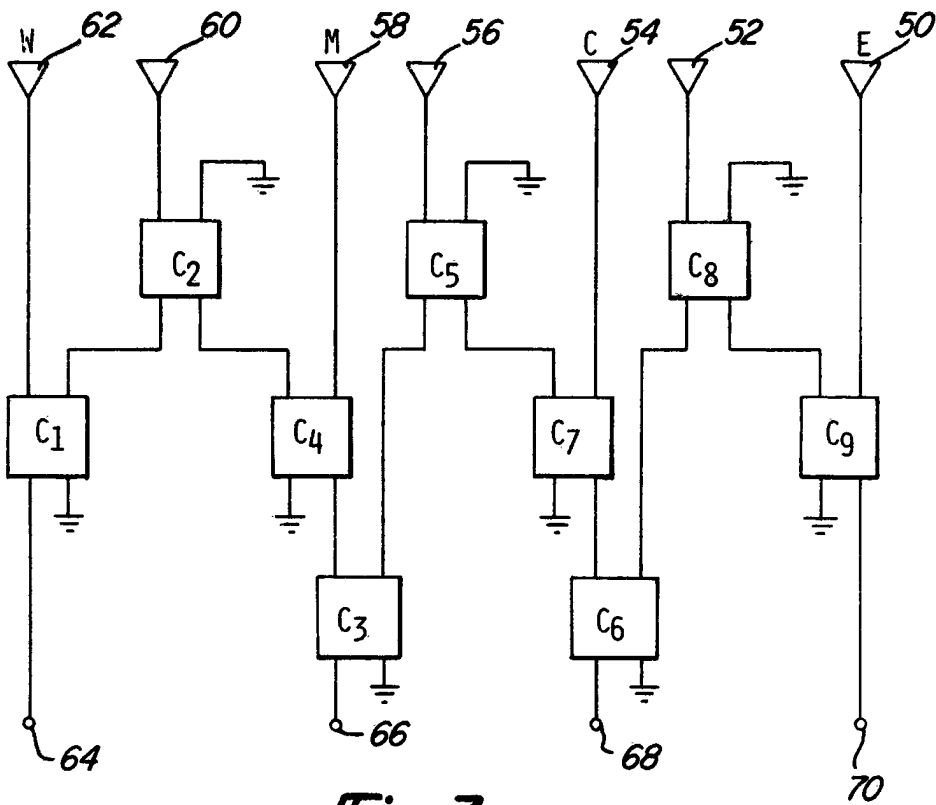

Fig-7

R1	1	5	9	13	2	6	10	14	3	7	11	15	4	8	12	16
R2	2	6	10	14	3	7	11	15	4	8	12	16	1	5	9	13
R3	3	7	11	15	4	8	12	16	1	5	9	13	2	6	10	14
R4	4	8	12	16	1	5	9	13	2	6	8	14	3	7	11	15
	T1				T2				T3				T4			

Fig-8

R1-FROM EAST	16	12	8	4	15	11	7	3	14	10	6	2	13	9	5	1
R2-FROM CENTRAL	1	13	9	5	1/16	12	8	4	15	11	7	3	14	10	6	2
R3-FROM MOUNTAIN	14	10	6	2	13	9	5	1/16	12	8	4	15	11	7	3	1
R4-FROM WEST	15	11	7	3	14	10	6	2	13	9	5	1	16	12	8	4

Fig-9

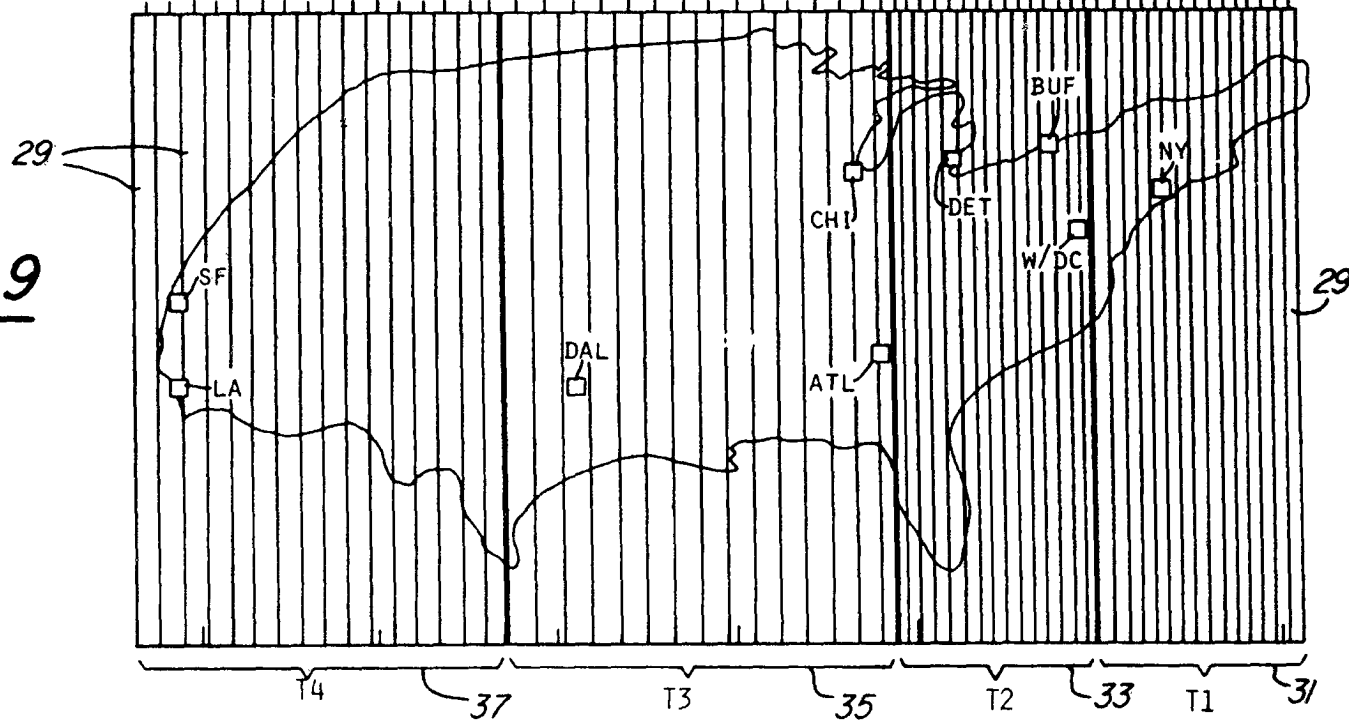

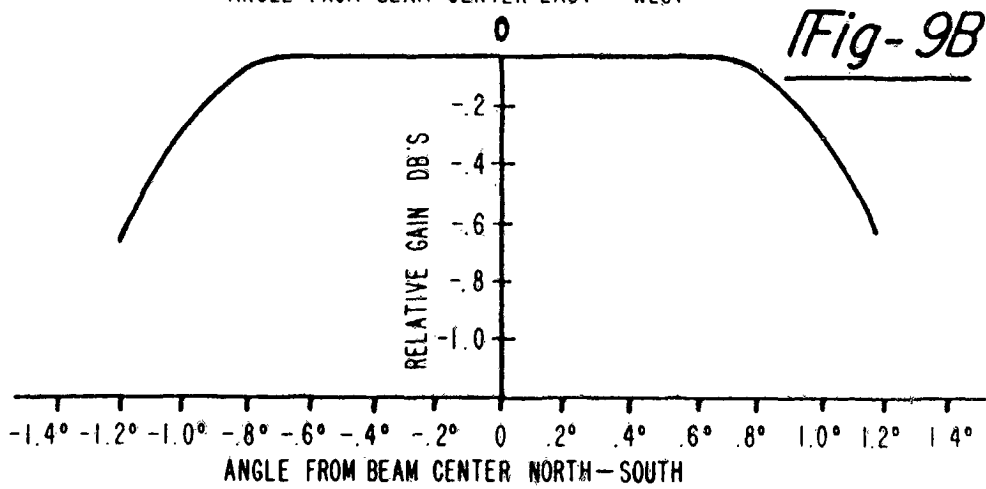
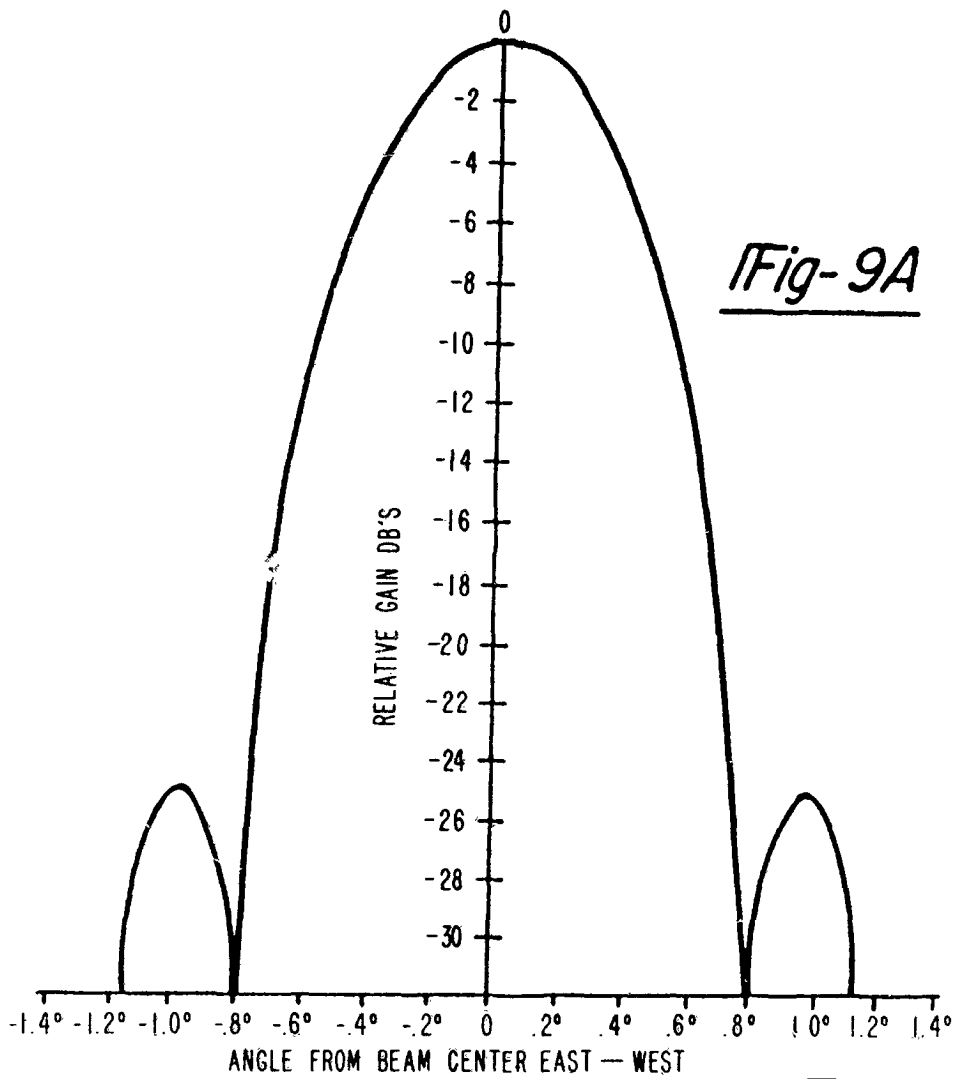



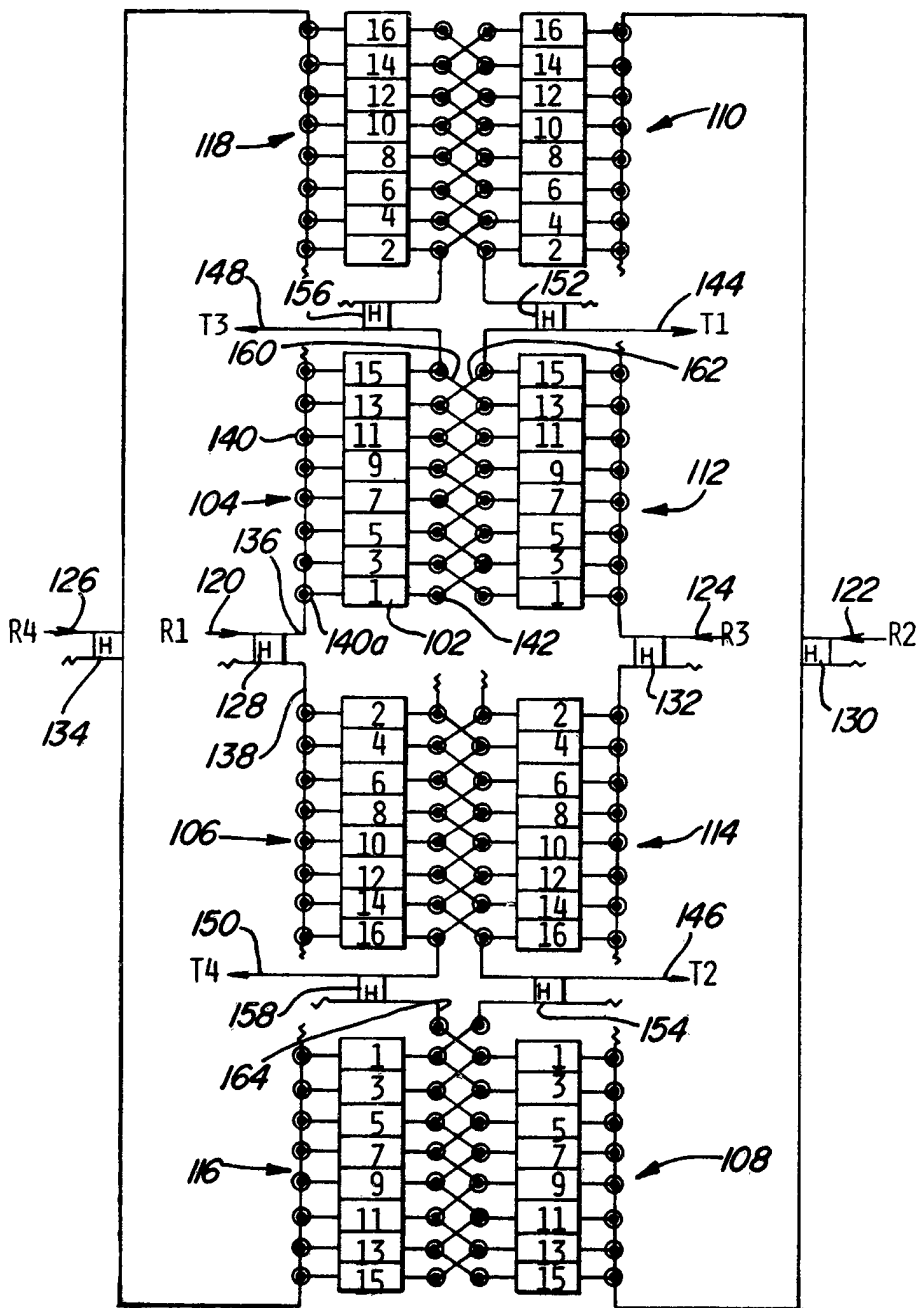

Fig-10

Fig-11

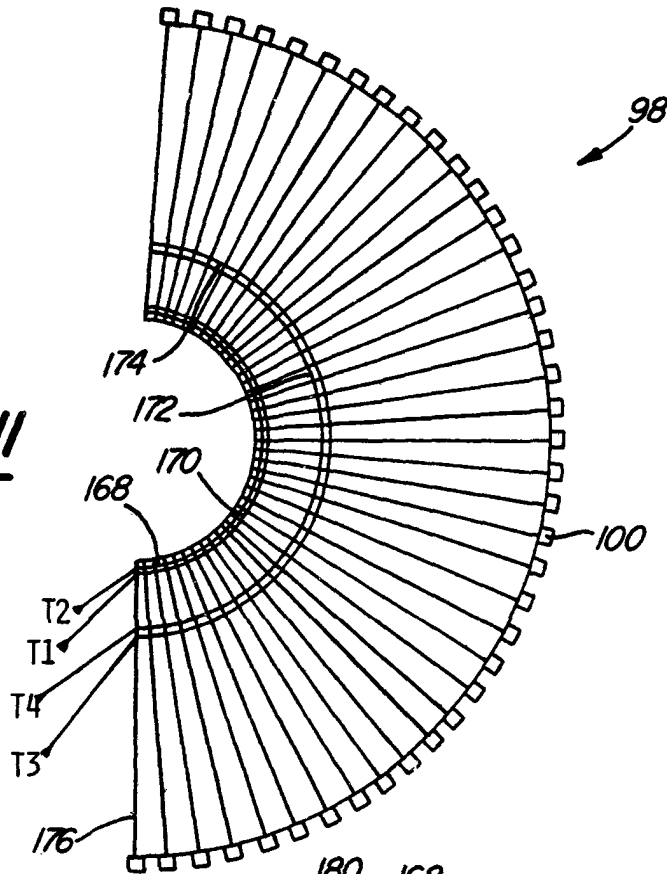
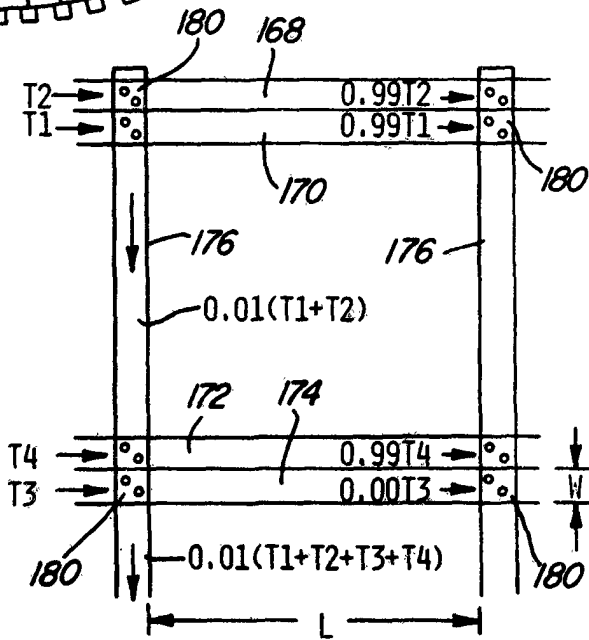
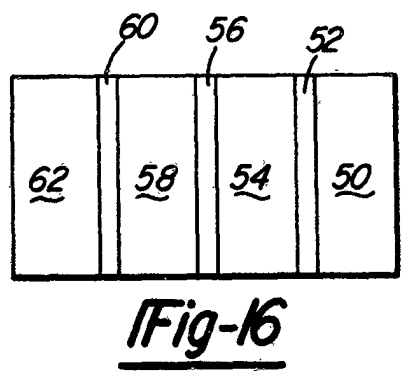
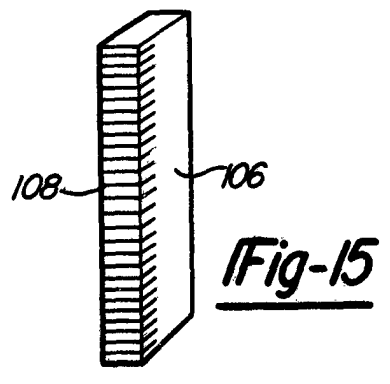
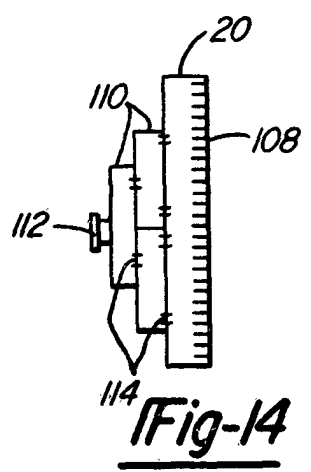
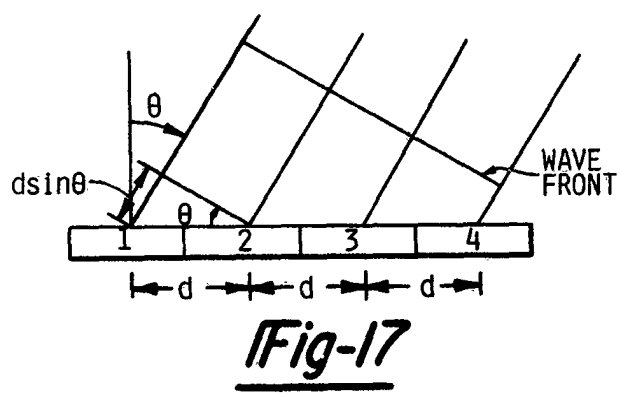
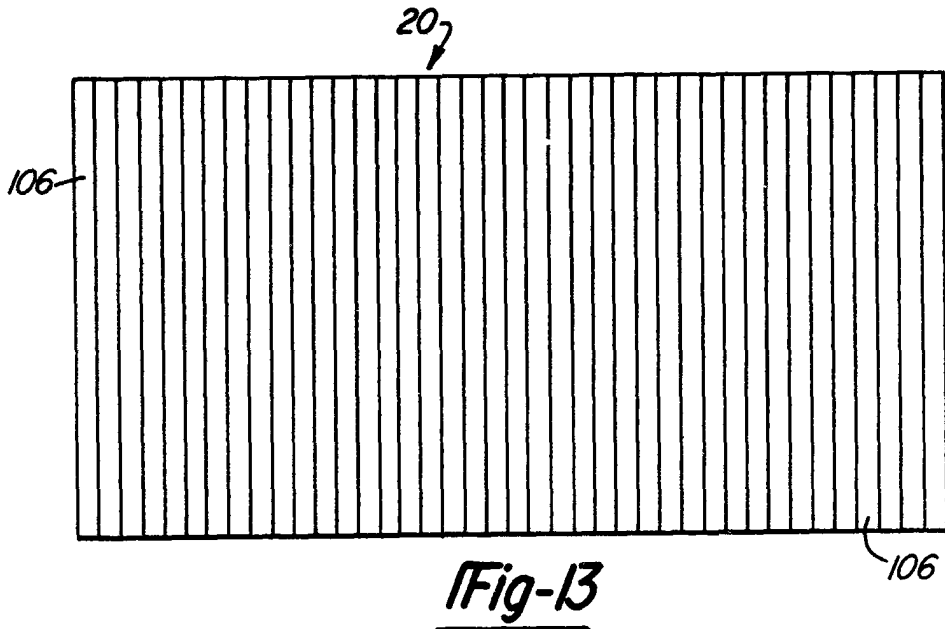

Fig-12





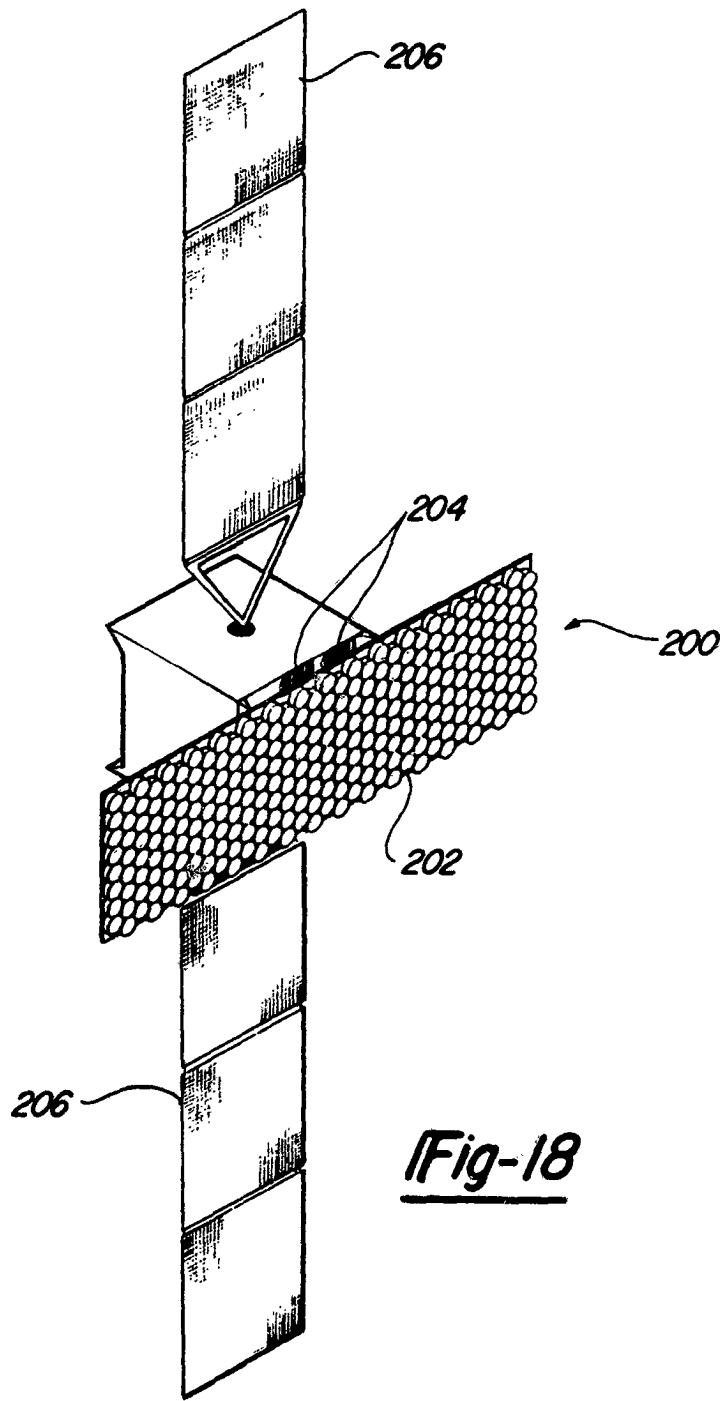

Fig-18

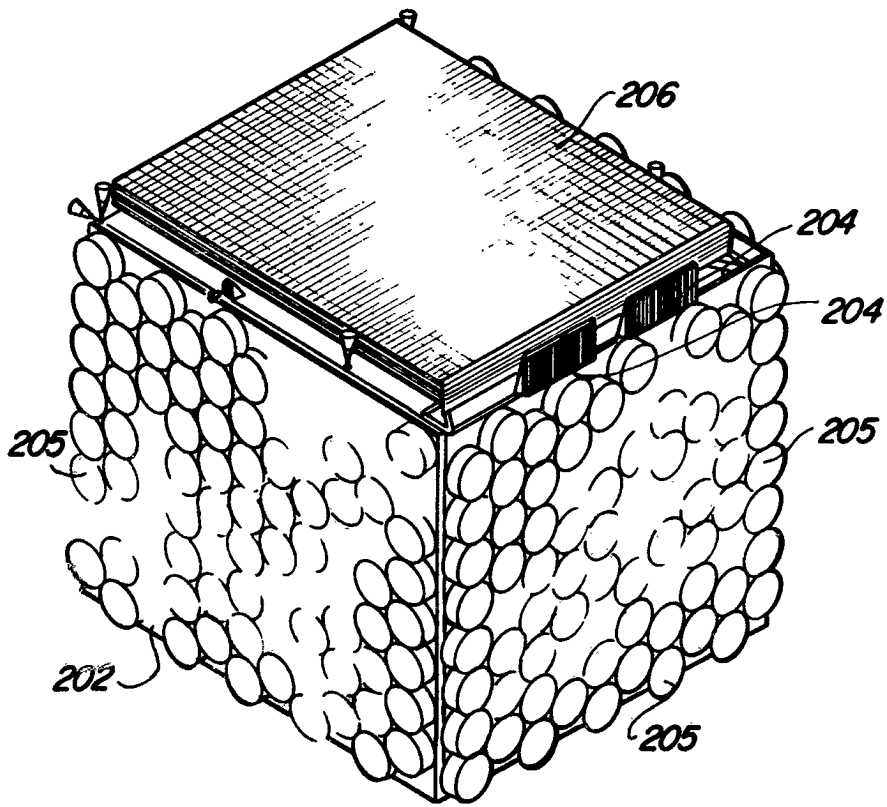

Fig-19

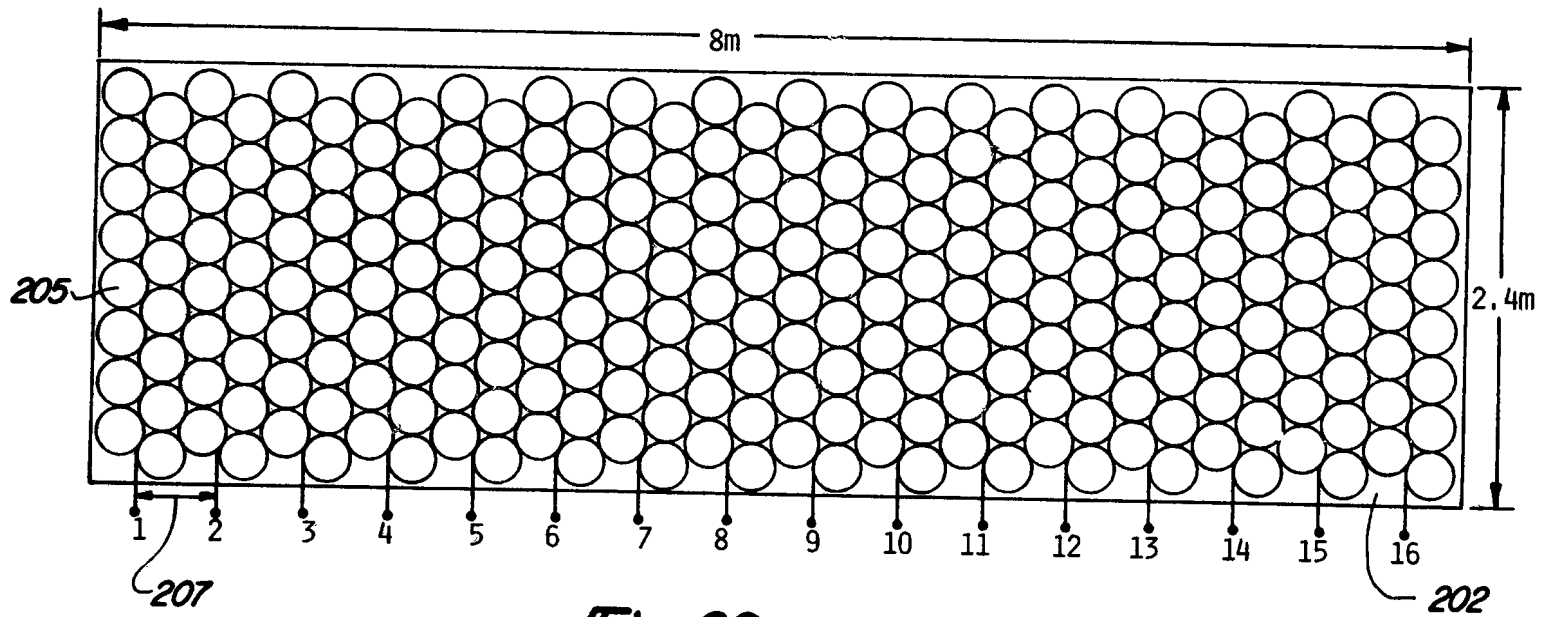

Fig-20

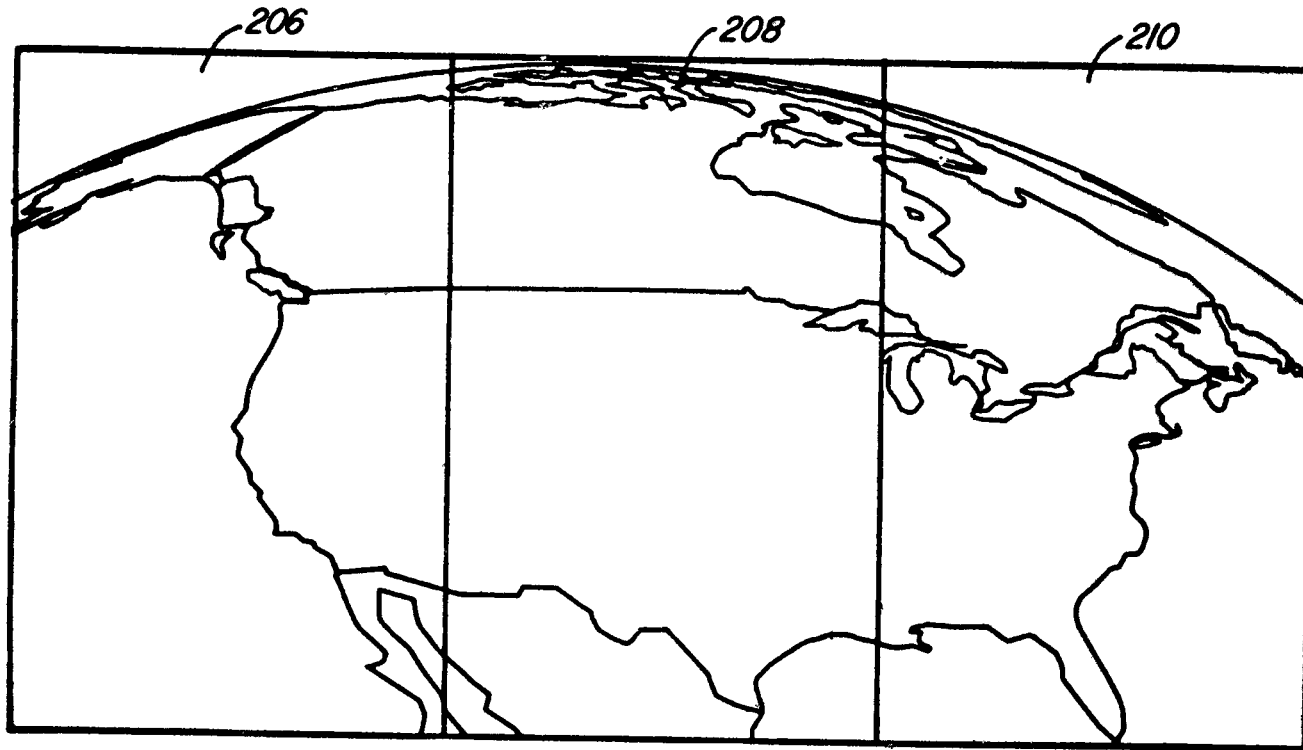

Fig-21

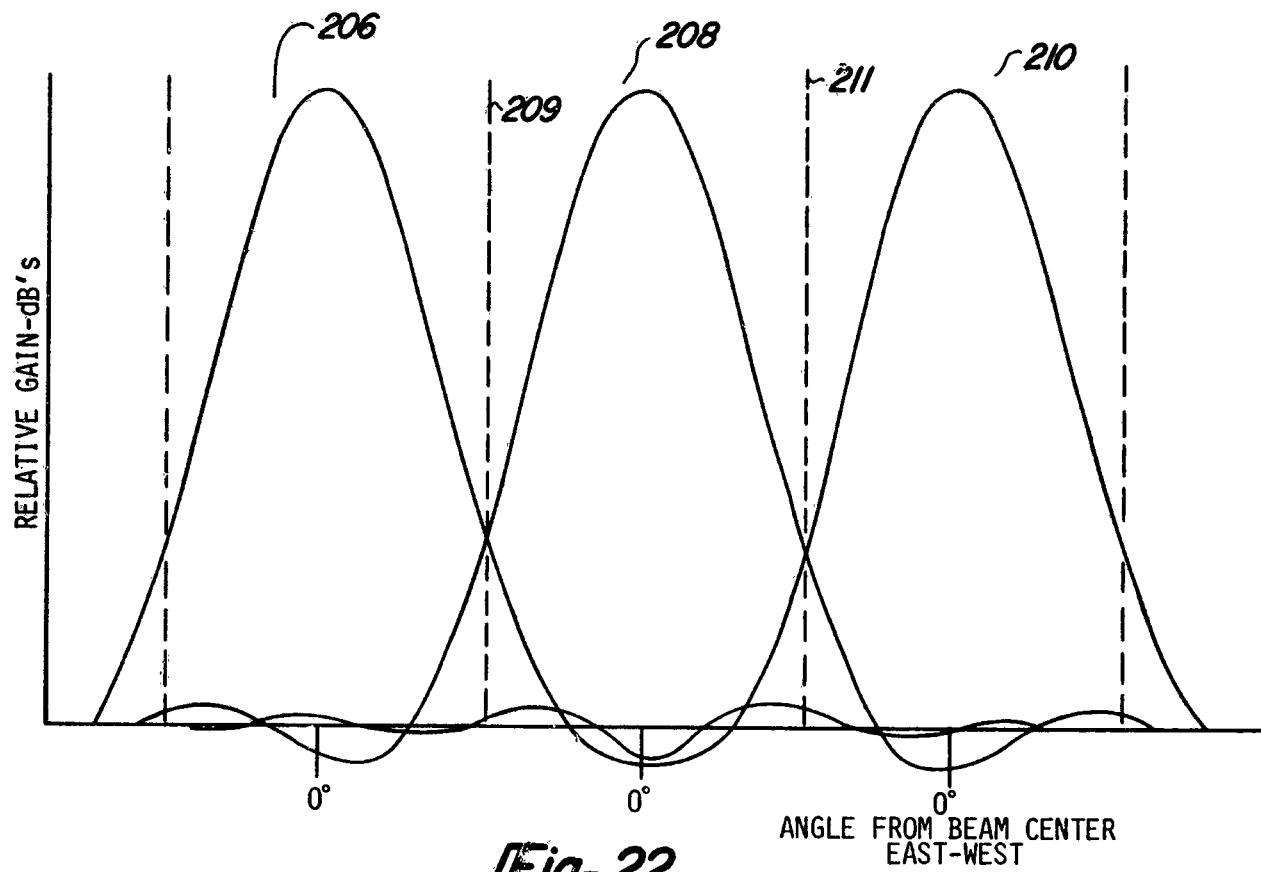

Fig-22



13 9 00 20178

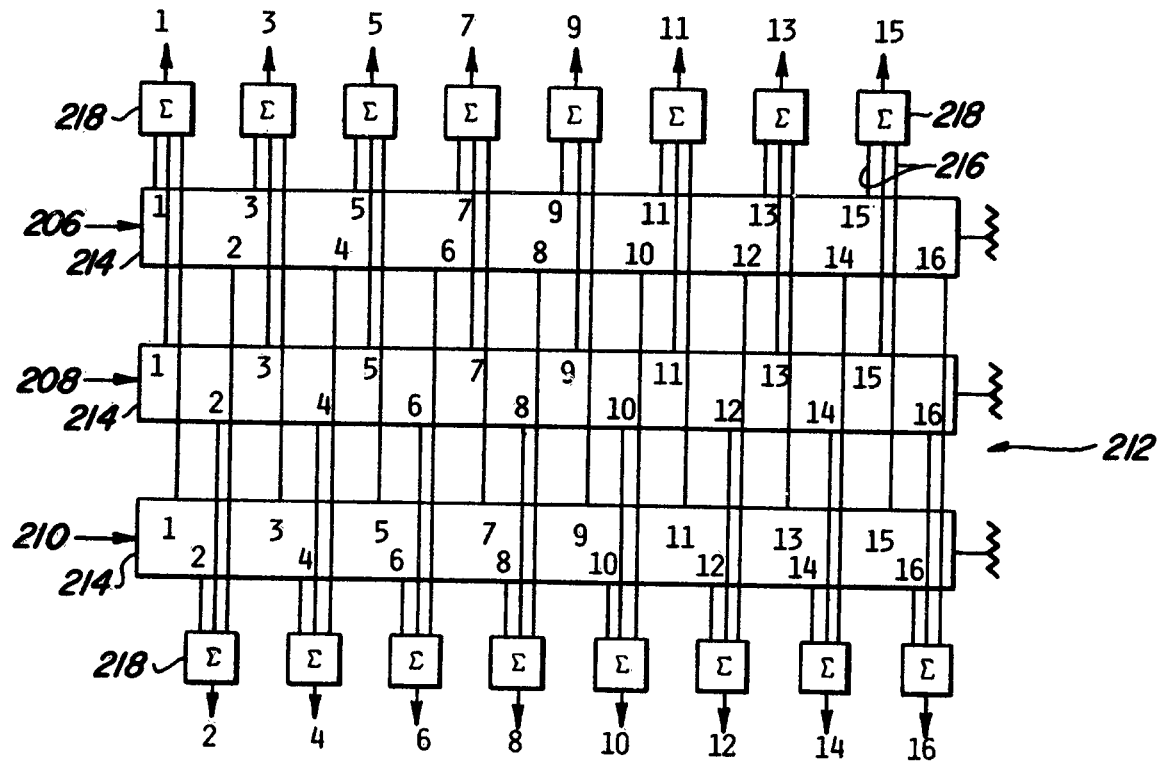

Fig-23

10 00 2070

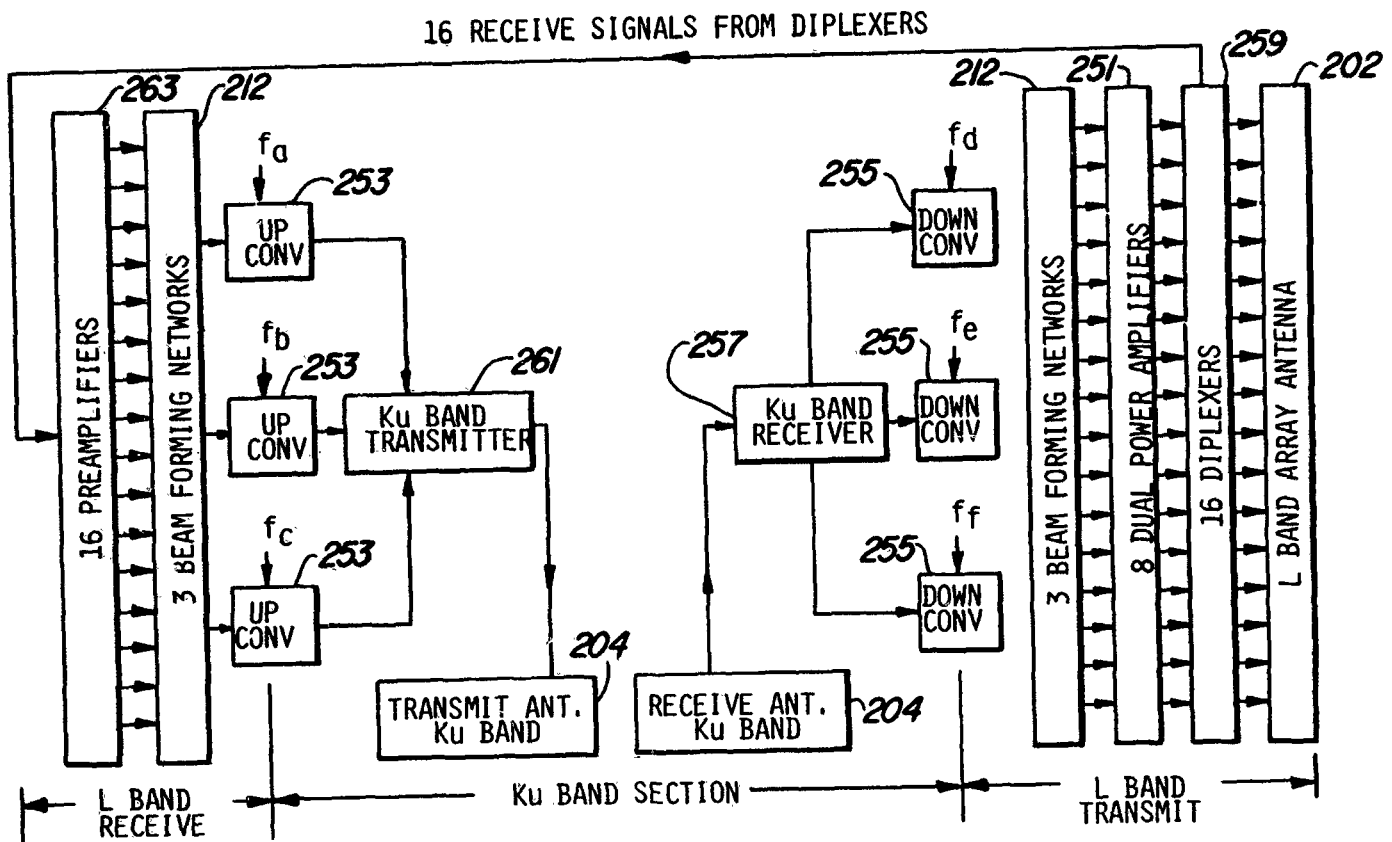

Fig-24

1 0 0 0 0 0 0 0 0 0 0 0 0 0 0 0

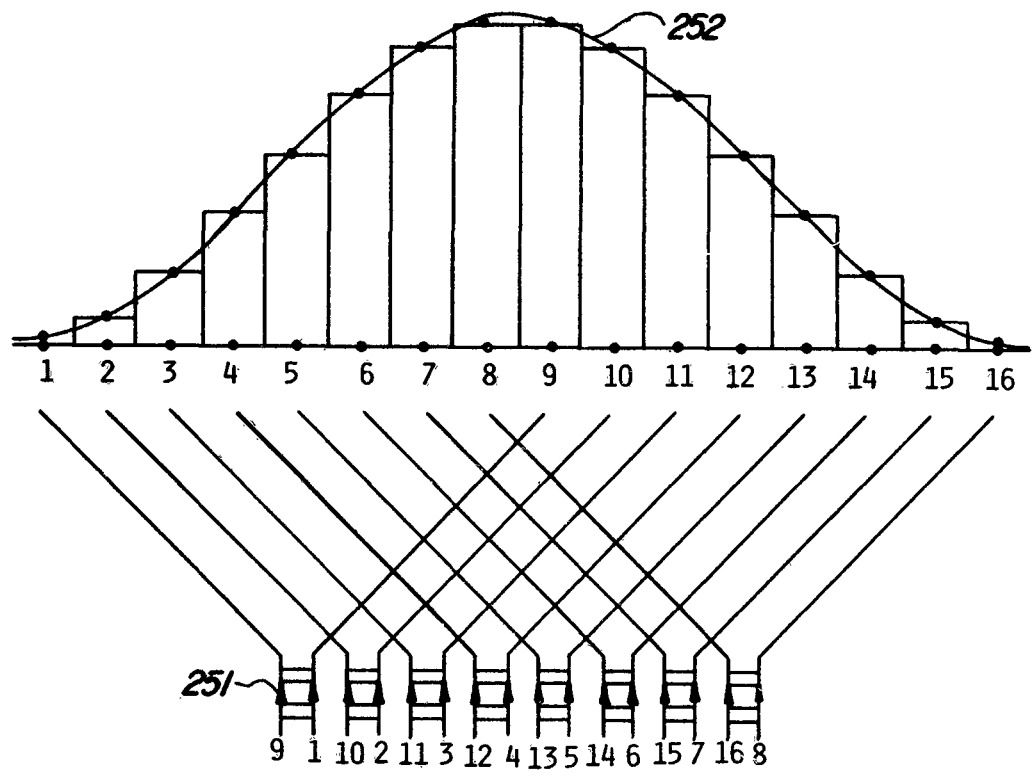

Fig-25

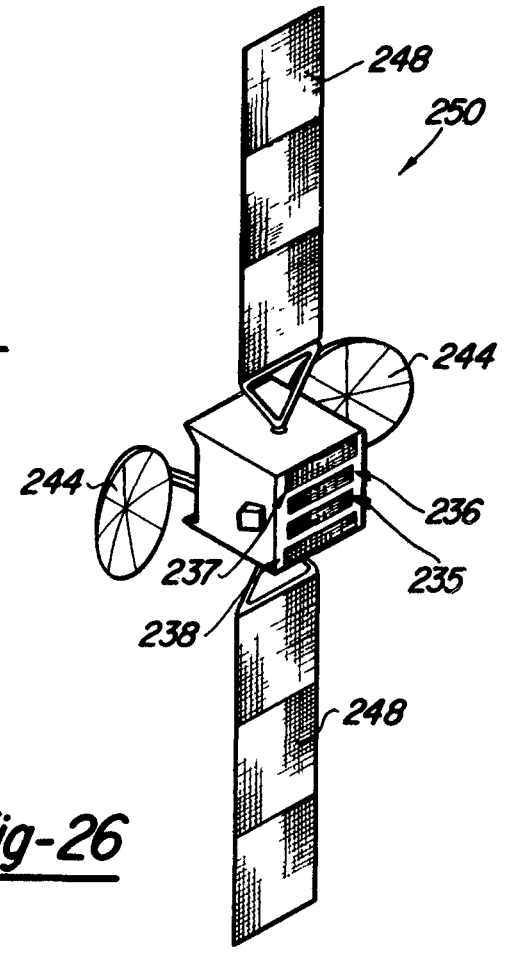
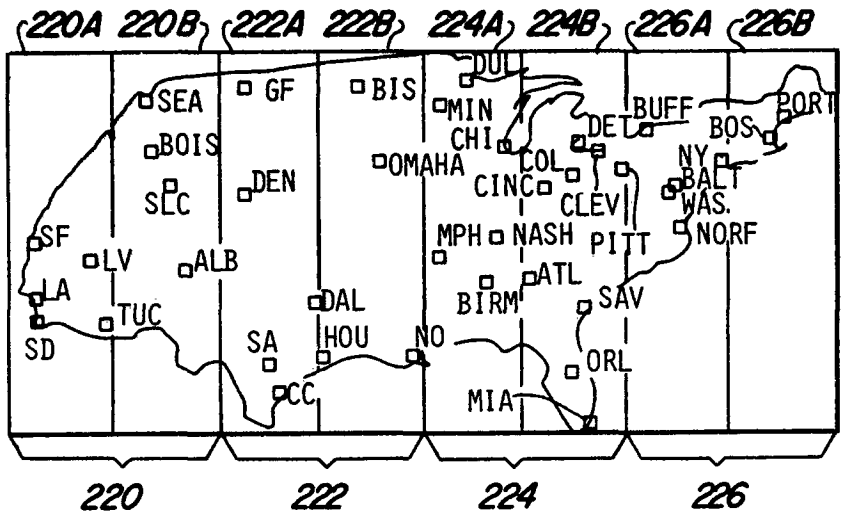
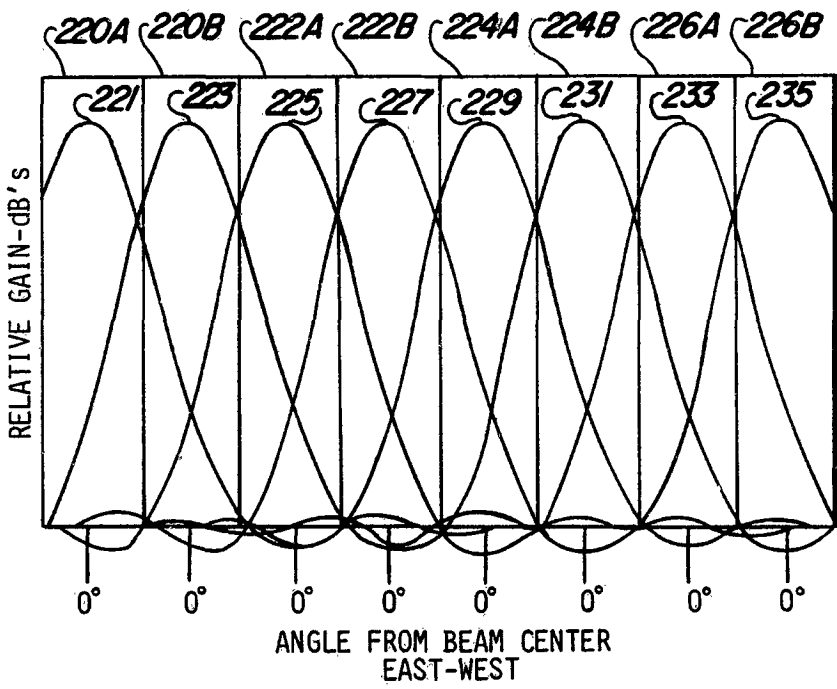

Fig-26



**Fig-27**



**Fig-28**

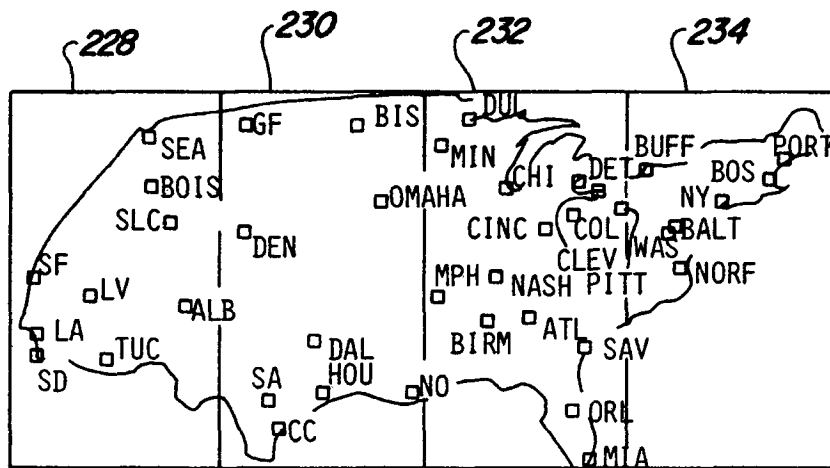

Fig-29

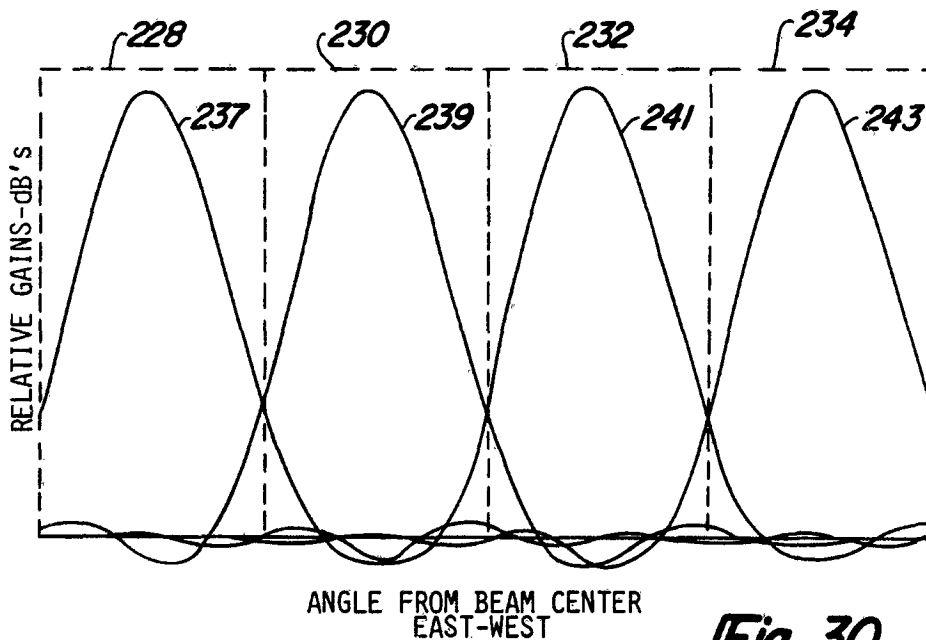

Fig-30

252

220A,B	RIA,B	1	5	9	4	8	3	7	2	6		
222A,B	R2A,B	2	6		1	5	9	4	8	3	7	
224A,B	R3A,B	3	7		2	6		1	5	9	4	8
226A,B	R4A,B		4	8	3	7	2	6		1	5	9
		T1			T2			T3			T4	
		228			230			232			234	

Fig-31

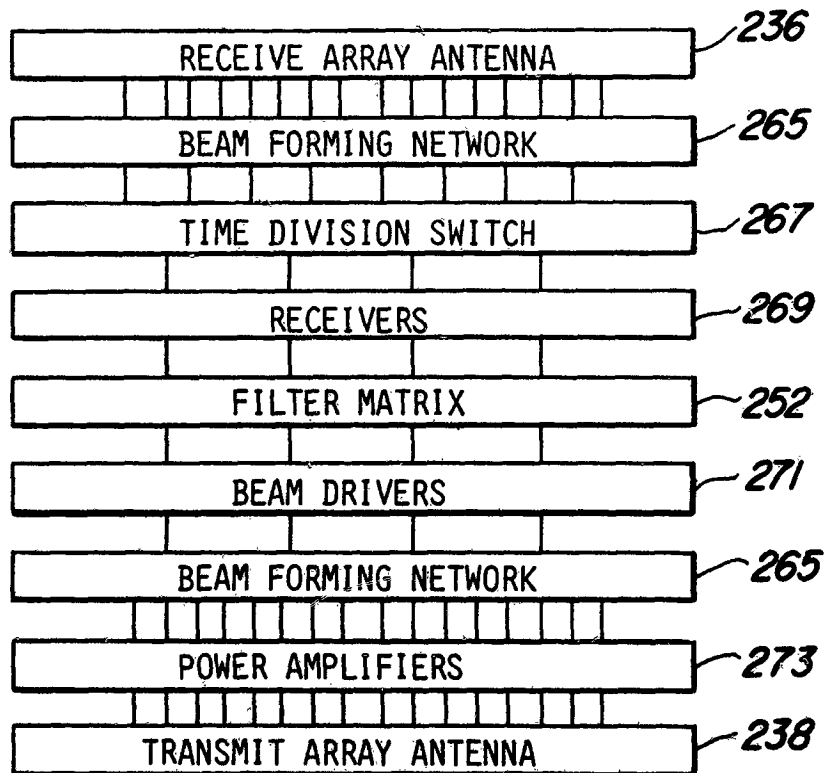

Fig-32