

# United States Patent

**Kuroyama et al.**

[11] **3,819,928**

[45] **June 25, 1974**

[54] **SWITCH KNOB LIGHTING DEVICE**  
[75] Inventors: **Toshinobu Kuroyama; Motoi Noba,**  
both of Toyota; **Takahiko Fukuyama, Mino; Nobuyuki Teranishi,** Nagoya, all of Japan

[73] Assignees: **Kabushiki Kaisha Tokai Rika Denki Selsakusho,** Nishikasugai-gun; **Toyota-City, Aichi-Pref.,** Toyota-City, Aichi-Pref., both of, Japan

[22] Filed: **Oct. 5, 1972**

[21] Appl. No.: **295,119**

[30] **Foreign Application Priority Data**  
Oct. 6, 1971 Japan..... 46-91762

[52] **U.S. Cl.** ..... 240/2 S, 200/167 A, 240/1 EL, 340/380, 350/96 R

[51] **Int. Cl.** ..... **F21v 33/00**

[58] **Field of Search** ..... 240/2 S, 1 EL, 2 R, 2.1; 340/380; 350/96 R; 200/167 A

[56] **References Cited**  
**UNITED STATES PATENTS**  
2,305,185 12/1942 Merkel..... 340/380 X

2,956,446	10/1960	Ensign et al. ....	200/167 A X
2,957,072	10/1960	Rigel.....	240/2 S
3,040,142	6/1962	Dietrich et al. ....	240/2 R X

*Primary Examiner*—Richard L. Moses  
*Attorney, Agent, or Firm*—Woodhams, Blanchard and Flynn

### [57] ABSTRACT

A switch knob lighting device for lighting a switch knob arranged on a dashboard of an automobile from the interior of the knob in combination with a switch structure. Said knob lighting device comprises an operating rod for operating the switch, a transparent rod of an optical fibre material fitted in a cylindrical hollow formed in said operating rod through the entire length thereof and a knob fitted over the top of the operating rod. The device further comprises a light source disposed at the inner end of the operating rod, a conic lens fitted in a hollow formed in the knob and a transparent indication plate fitted to the outer face of the knob. Thus, the light issued from the light source is introduced straight through the transparent rod and diffused by the conic lens thereby to illuminate the indication plate from the interior of the knob.

**2 Claims, 2 Drawing Figures**

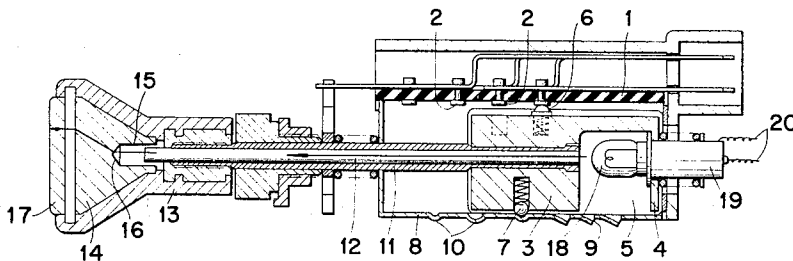

3819928  
OR IN 240/2S

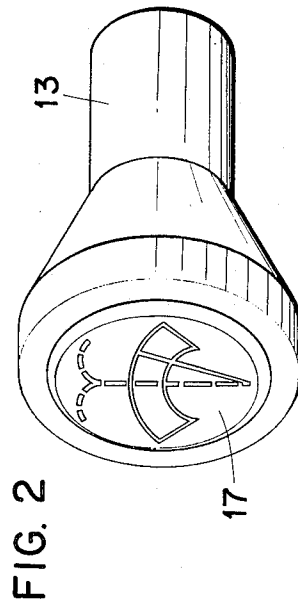
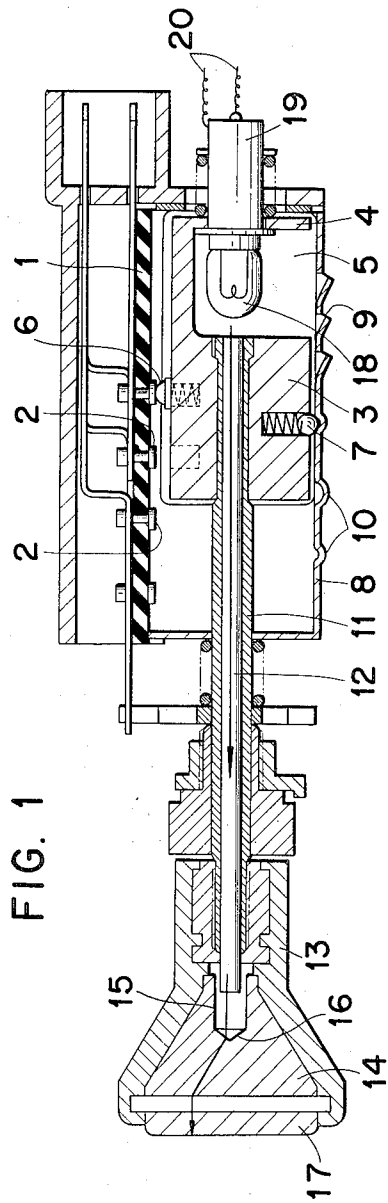

## SWITCH KNOB LIGHTING DEVICE

This invention relates to a switch knob lighting device and, more particularly, to a device for internally lighting a switch knob arranged on a dashboard of an automobile.

Difficulty has been experienced in operating in the dark switch knobs such as a wiper switch knob, a lighting switch knob, etc. arranged on a dashboard of an automobile. For overcoming the difficulty, a knob incorporating therein a lighting means is introduced to the art.

However, such a knob as above described has defects that the knob becomes inevitably bulky since it contains therein not only a lamp but also a socket therefor, and that the light is too intense to be properly controlled since the light source is located at too small a distance from the face of the knob.

It is, therefore, an object of the present invention to provide a switch knob lighting device which can make the knob compact since it is not necessary to incorporate the light means in the knob itself.

It is another object of the present invention to provide a switch knob lighting device of the type described in which the light for illuminating an indication plate mounted on the top of the knob can be maintained constant and at a small intensity.

It is still another object of the present invention to provide a switch knob lighting device of the type described in which the light from a light source can be introduced to the indication plate and diffused to illuminate the same in high efficiency and, therefore, the candle power of the light source can be made small to avoid overheating.

Essentially, according to the present invention, there is provided a switch knob lighting device consisting essentially of an operating rod for managing make-and-break operations of a switch, said operating rod having a cylindrical hollow axially extending through the entire length thereof; a transparent rod fitted in said hollow; a light source disposed in a lamp chamber integrally formed with the operating rod or rigidly fixed thereto; a knob fitted on the end of the operating rod and formed therein with a conic hollow enlarging outward in diameter; a conic lens fixedly disposed in said conic hollow; and a transparent indication plate fitted to an outer end of said knob to close said conic hollow; said transparent rod facing said light source at its inner end and facing said lens at its outer end whereby light emitted from the light source is transmitted straight through the transparent rod and is diffused by means of the lens thereby to illuminate the indication plate from the interior.

Various further objects, features and advantages of this invention will be made apparent from the following description of an embodiment of the invention taken in connection with the accompanying drawings, in which:

FIG. 1 is a longitudinal sectional side view taken along a central line of a knob lighting device in combination with a sliding switch system which is an embodiment of the present invention; and

FIG. 2 is a perspective view of the switch knob.

Referring now to the drawings, an insulator 1 carrying a row of fixed contacts 2 is fitted to a case 8. Said case 8 contains therein a contact holder 3 which has a movable contact 6 and is slidable along said insulator

1. Said contact holder 3 includes a lamp chamber 4 which is formed in its rearward end and opens at 5 toward the bottom of the case 8 in which apertures 9 corresponding to the opening 5 are formed for ventilation. Further in said bottom face of the case 8, there are formed recesses 10 for engageably receiving a detent ball 7 which is adapted to project from the contact holder 3 by means of a spring.

An operating rod 11 having an axially extending central opening is fixedly inserted into the contact holder 3 so that said central opening communicates with the lamp chamber 4. A transparent rod 12 of an optical fibre material such as an acrylic resin or the like is fitted in said central opening of the operating rod 11 and extends through the entire length thereof and the front end of the transparent rod 12 slightly projects beyond the front end of the rod 11. To the front end of the operating rod 11 is fitted a switch knob 13 which has a conic recess to encase therein a nearly conic lens 14 which progressively enlarges in diameter toward the front end. In the center of the inner face of said lens 14 is formed a blind hole 15 for receiving the projecting front end of said transparent rod 12 confrontingly, and thus, the inner face of the lens 14 acts as a concave surface for diffusing light. The lens 14 is covered with an indication plate 17 of a transparent material fitted over the outer face of the knob 13. Said indication plate 17 has indicia marked thereon as seen in FIG. 2.

In the lamp chamber 4, there is provided a light source 18 such as a lamp confronting the inner end of the transparent rod 12. A socket 19 for receiving said lamp 18 is fixed to the contact holder 3 so that its rearward end projects through an opening formed in the case 8. Lead wires 20 are connected to the projected end of said socket 19.

In mounting the sliding switch system according to this invention on a dashboard of an automobile, the lead wires 20 are connected to a light switch. When the present switch system is utilized as a light switch itself, the lead wires 20 are connected to the fixed contacts 2 to complete a light switch circuit in combination with the movable contact 6.

In the structure as above described, the light from the light source 18 is transmitted in the cylindrical hollow of the operating rod 11 through the transparent rod 12 to be diffused in the interior of the knob 13 by means of the concave surface of the lens 14 as shown in an arrow line in FIG. 1. Thus, the indication plate 17 can be effectively illuminated from the interior by the diffusion of the light.

Since the light from the lamp 18 is introduced straight through the transparent rod 12 in the long operating rod 11, the light arrives at the lens 14 in high efficiency without waste of light through unnecessary diffusion. Therefore, the candle power of the lamp 18 can be made small to avoid overheating.

Further, in the present device, the operating rod 11 is rigidly fitted to the contact holder 3 which securely holds the lamp 18. This means that the distance between the lens 14, the transparent rod 12 and the lamp 18 is constant at all times and the intensity of the light illuminating the indication plate 17 can be always kept constant.

Moreover, the switch knob itself can be made compact and presents a good appearance completely overcoming the defects of the prior art. The switch knobs for respective purposes can be recognized in the dark

3

4

with no need of groping as in the conventional switch structure.

It is apparent that the switch knob lighting device of the present invention can be used in combination with other switch systems than the sliding switch systems herein described.

It is intended, therefore, that all matters contained in the foregoing description and in the drawings shall be interpreted as illustrative only not as limitative of the invention.

What is claimed is:

1. A switch having a lightable knob, comprising an elongated movable operating rod for effecting make-and-brake operations of the switch, said operating rod having an axially extending central opening through the entire length thereof; a transparent rod mounted in said opening and extending substantially the entire length thereof; means defining a chamber integrally formed with the operating rod or rigidly fixed thereto for movement therewith and communicating with the inner end of said central opening; a light source in said chamber in confronting relationship to the inner end of said transparent rod; a knob mounted on the outer end of the operating rod and having formed therein a conic recess which progressively enlarges in diameter toward the outer end thereof; a conic lens fixedly disposed in said conic recess at a fixed distance from said light source; and a lightable indication plate mounted on the outer end of said knob and closing the outer end of said conic recess; the inner end of said transparent rod facing said light source and the outer end of said transpar-

ent rod facing said lens whereby light emitted from the light source advances straight through the transparent rod and is diffused by means of the lens thereby to illuminate the indication plate from the interior; a switch case and means supporting said operating rod for longitudinal sliding movement relative to said switch case; an insulator fixedly attached to said switch case and provided with a plurality of fixed contacts connected to an electric source; a contact holder slidably disposed in said switch case and being fixedly connected to said operating rod and carrying a movable contact for selective engagement with said fixed contacts, said contact holder having said chamber formed therein, said light source being an electric lamp fixedly disposed in said chamber for movement with said contact holder; and lead wires extending from the lamp and connected to either a further switch or said fixed contacts; said operating rod being rigidly inserted into the contact holder to communicate with said chamber and adapted to slidingly shift the contact holder along said insulator and to stop the holder at positions in which said movable contact comes into contact with one of the fixed contacts thereby to light the lamp.

2. A switch according to claim 1, in which said switch case and said contact holder have cooperating releasable detent means for selectively releasably holding said contact holder in a plurality of spaced-apart positions in said switch case in which said movable contact engages different ones of said fixed contacts.

\* \* \* \* \*

35

40

45

50

55

60

65