

(19)
(12)

(KR)
(B1)

(51) 。 Int. Cl. 6
H01L 29/786

(45)
(11)
(24)

2001 07 12
10 - 0290509
2001 03 02

(21) 10 - 1997 - 0065904
(22) 1997 12 04

(65) 1998 - 0063789
(43) 1998 10 07

(30) 96 - 344513 1996 12 10 (JP)

(73) 가 가 가
가 가

1 6 2

(72) 1 - 32 - 6 - 502

1 - 13 - 2 - 202

(74)
:

(54)

, ITO

1 TFT

2

3

4

5 4

6

7a

7b 7a K - K

8

9

10a

10b 10a L - L

11

12

13 12

14 TFT

15

16

17 TFT

18

19

20
21
22
23
24
25

101: 107:

109: 108, 110, 115:

116: (intrinsic)

117: 120, 123S, 123D:

120: 121, 126, 127, 173:

123S, 123D: n + 137S:

137D: 138:

(TFT)가 TFT (AI)
17 25 (201)
17 (202) (203)가 (203A) (204)
(204) (203) 가 (203A) (202)
(205) (203) 18 (206) 1
9 (208), (209) (207), (209)
(210) (B - HF) (202) (209A)

11B) (209) n + , 20 n +
(island) (208A) (islands) (211A, 2
21 ITO(indium tin oxide) (island) (208A)
(220) ITO (212)
22 (213A) (213)
가 (203) (207) (207A) (213)
203) (215), (214) (216) TFT 24 23
) (217) (218) (219)
TFT ()
acid) (209A) (hot phosphoric
(209) 가 25 (218) 19
(208) () 1000 (208)
(207) (203) (207)
(4) (203A)
25 (2A) (219) (203)
가
19 21 (212) ITO
(203A) (207) (207)
250 가 (203) (hillock) 가
TFT

가

가

TFT

1 10b

TFT

TFT

1

(101)

(102)

(103)

(101)

(102) , 1

(103)

(延在)

(101)

(103

)

(103)

가

(103)

(106)

(105)

)

가 120nm 180nm
0nm

(109)

(108)

2
가 100nm 200nm

(103)

(107)

(102

00nm 200nm

가 120nm 180nm

(111)

(109)

(110)

가 100nm 200nm

(105)

가 100nm 200nm

(106)

가 1

가 100nm 200nm

가 100nm 200nm

가 120nm 180nm

(113)

가 120nm 180nm

(114)

2

(105)

3 가 200nm 300nm (116) (117) CVD (107) (117) (107) (116) 가 100nm (118) (109) (118) (116) (107) (119) (110) (106) (110) (118, 119) (117) (122) (109) (106) (115), (116) (119) (119) (121) (116) (115) (109)가 (112) 4 20nm 30nm CVD (118, 119) n + (107) (islands)(123S, 123D) (124) 가 (124) (122) (island)(120) (116) (island)(120) (107) 가 (islands)(123S, 123D) (116) 가 , (CCI₄) (115) (122) (122) (O₂) 가 (109) (116) (121) (117) (125) (127) (126) (127) (125), (127) (121) (127) (121) 6 (127) 4 5 6 (121) (124) (128) (124, 125) ITO 6 (island) (123S) 30nm 100nm (129) 가 , ITO (115)

) (109) (106) 가
 . (109) (115) (126)
 (121)
 (109)가

(128) 7a 7b 7a
 , 7b 7a K - K . 7a

(109) (130) (131) (130)
 (109) (126) (121) .
 , (109) (109) (121) , (109)
 (106) W_{CN1} (126) (121) W_{PR} , W_{PR}
 (130) W_{CN2} 가 (131) (131) (13)
 0) (126) (121) , (110)
 가 , (131) ,
 가 (SF₆) (CF₄) 가

8 (109) (121), (126)
 (115) (109) (106) .

(131) , 9 (Cr) 가 10nm
 30nm 1 (139) 1 가 330nm 400nm 2
 (140) () (136) . () (1)
 36) . (109) (134) (135)
 , (134, 135) , (137S), (137D),
 (137D) (145) (138) .

10a 10b 10a L - L 10b
 (129) (142) (138) (143) .
 , 가 100nm 300nm (141) , (138)
 (137D) (144) .

(106) W_{CN1} , (130) (115) W_{CN2} (143)
 W_{CN3} (138) W_{PD} ,

W_{CN1} W_{CN2} W_{CN3} W_{PD}

가 TFT (109)가 , 가
 가 TFT

(151) (101) (129) (152)가
 (152) (141) (145) (111)
 (153)가
 (154) (154) ITO (153)
 (155) (156) (155)
 (seal) (157)가 (156) (144)
 156) (157) (158) (101) (151) (144,
 , 151) (144, 156) (101)
 (159, 160) (138)
 () (111) (161)
 (162) (161) (163)가 (101)

12 7a 7b (121) (126)
 (130) (131) (121) (126) (
 132) (121) (126) (133)
 (121) (126) (132)
 (133) 가 , 13 (121) (121)
 A), (126) (126A) (115A)가 (121)

(121A, 126A) (138) (138)가 (115A)
 (109) (138)

14 16 TFT

(107) 14 (116) (122)
 16) (109) (109) (122) (1
 lands) (123S, 123D) (171, 172) (122) (is
 (116) (126) (173)
 (109) (172) (island) (120) (126) (126)
 (173) (106) (106) (126)

15 (171, 172) ITO
 (174) ITO (175)
 9) 가 - (175)
 (173) (126) (115) (10
 (109)가

16 (176) (176)

177)가 , (173) (126) ((176) (islands)(123S, 123D), (115) 8 (1 (109)가 가 . (175)

, TFT , , 가 . , (109) (island) (island)

(57)

1.

2.

1 ,

3.

2 ,

4.

2 ,

5.

2 ,

indium tin oxide

6.

1 ,

7.

1 ,

8.

1 ,

9.

1 ,

n +

10.

1 ,

(intrinsic)

11.

1 ,

(intrinsic)

, n +

12.

1 ,

(intrinsic) n +

13.

1 ,

(intrinsic) (island) n + (islands) ,
(island) (intrinsic) (island) (intrinsic)
(island) n + (island)

14.

1 ,

(a) (intrinsic)

(b) ,

(c) ,

(d) (intrinsic)
n + (island) ,

(e) (intrinsic)
(intrinsic) (island) ,

(f) (intrinsic)

15.

1 ,

16.

1 ,

17.

1 ,

,

,

18.

1 ,

.

.

19.

,

,

,

,

.

.

20.

19 ,

,

21.

19 ,

n +

.

22.

19 ,

.

23.

19

n +

1

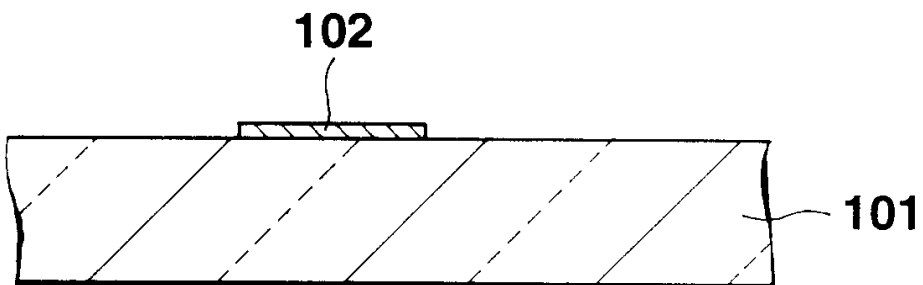
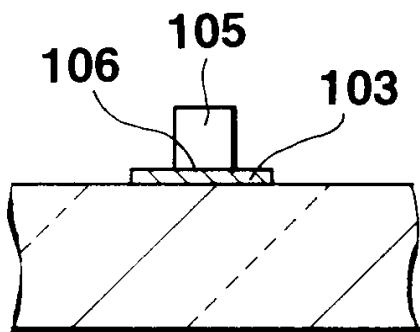

2

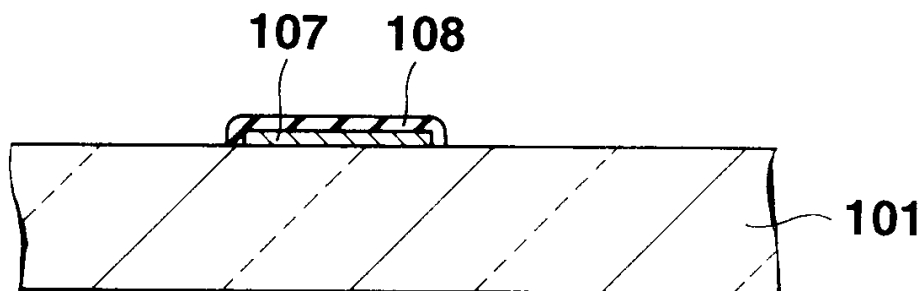
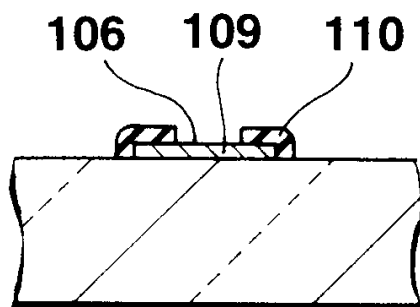

3

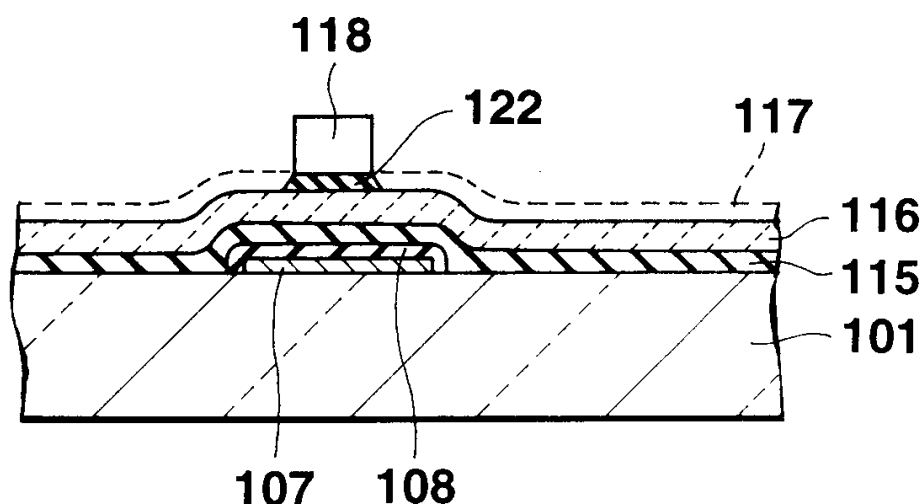
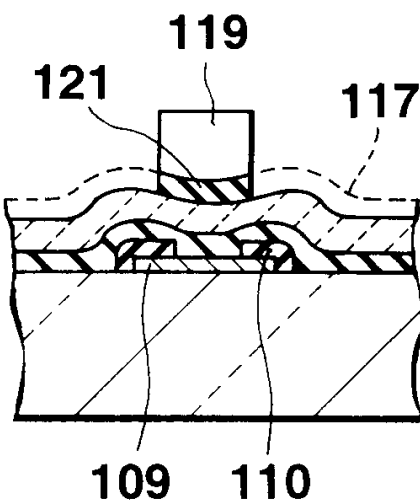

4

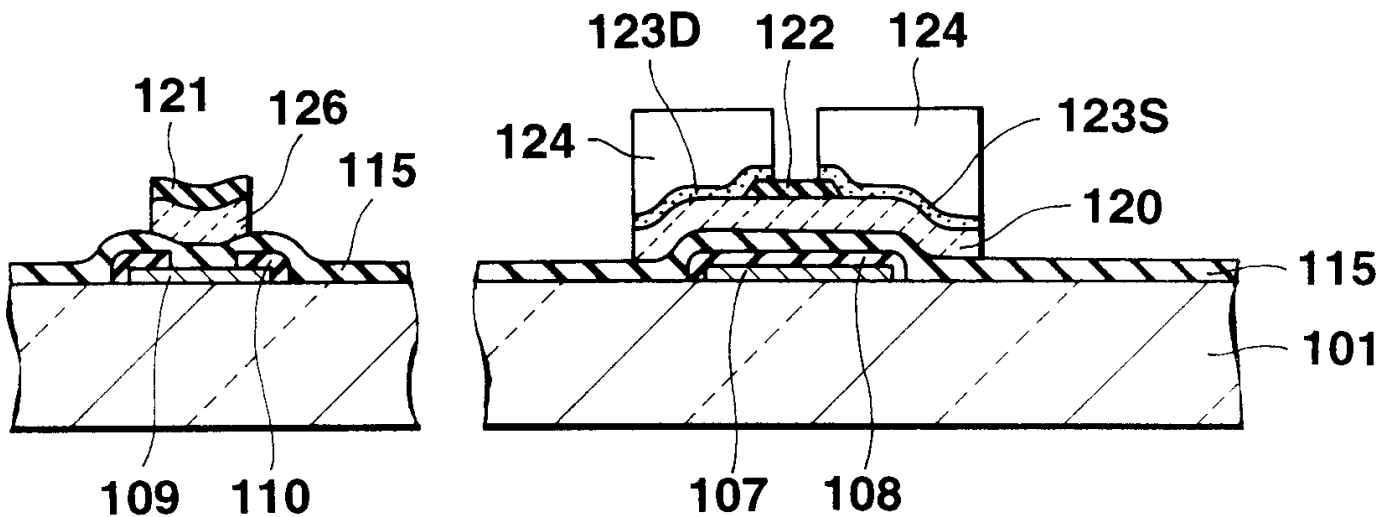

5

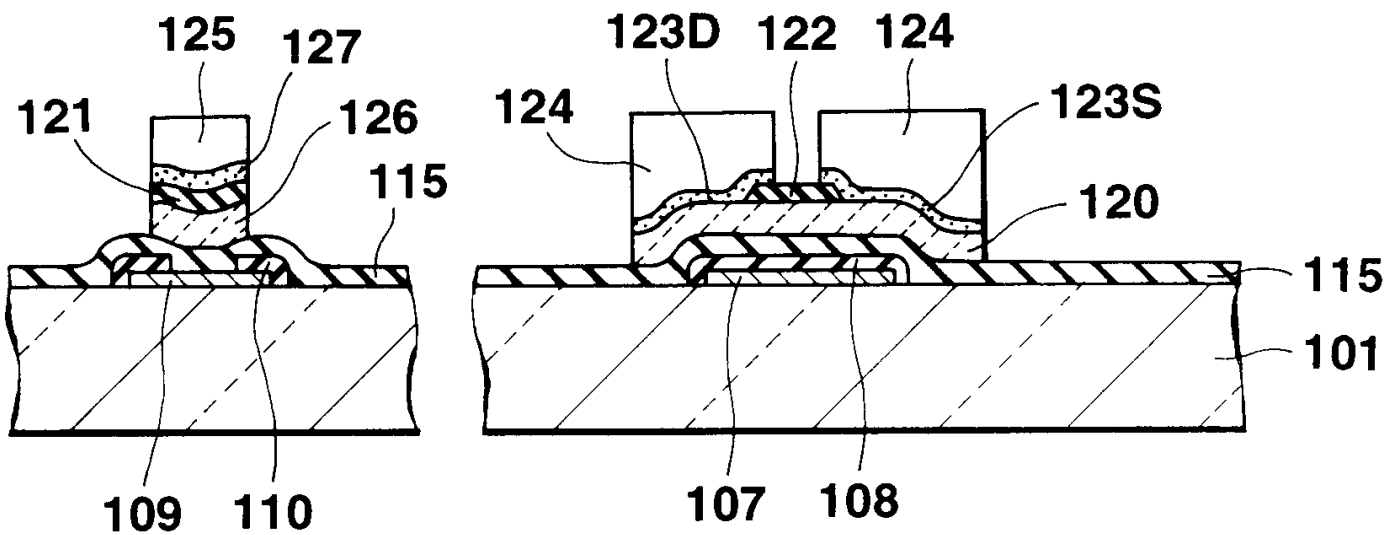

6

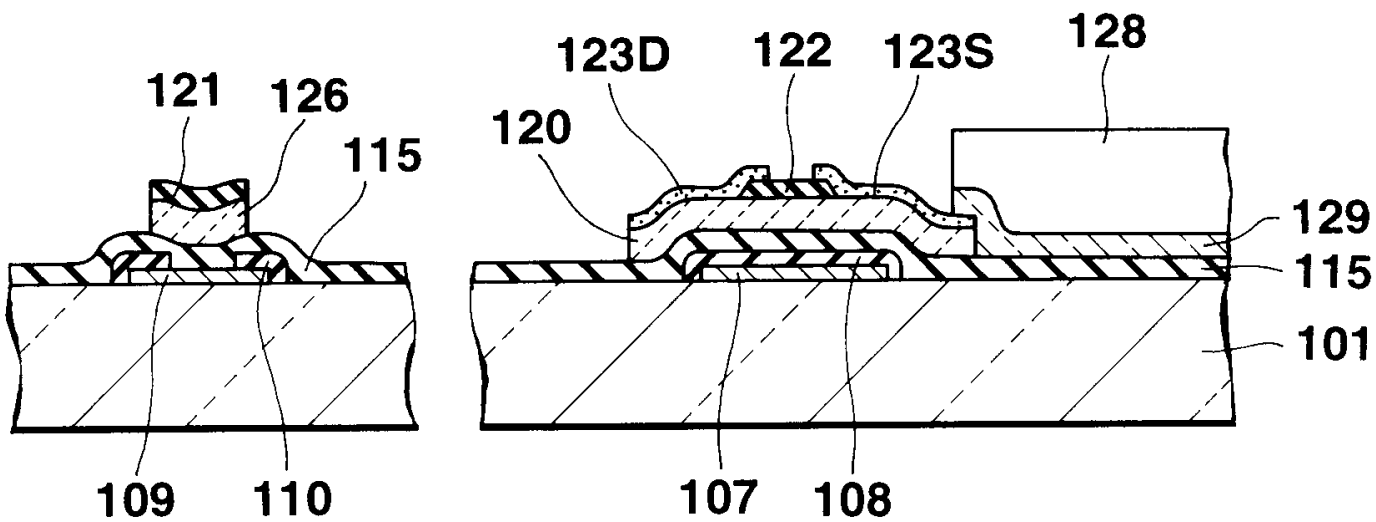

7a

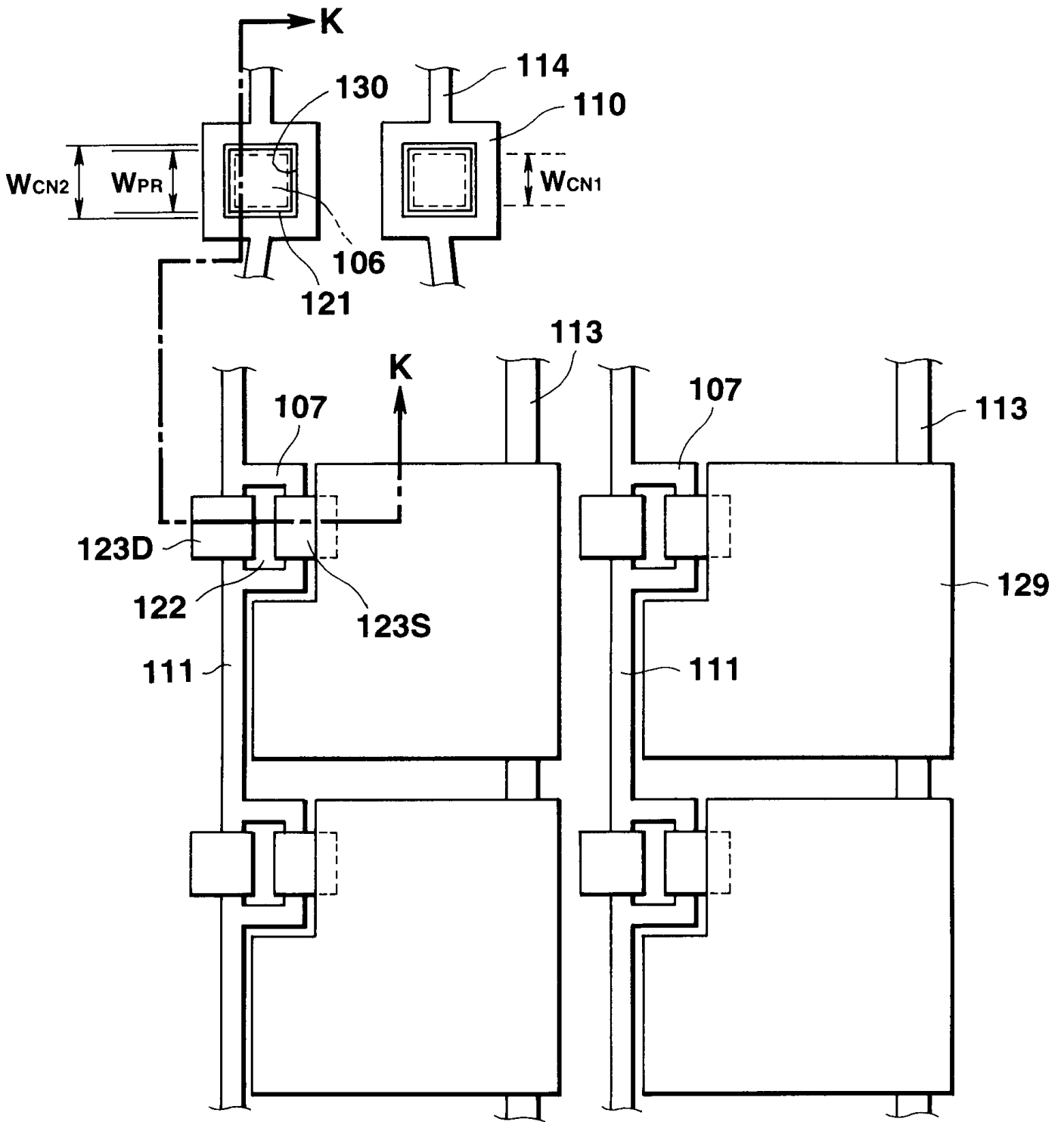

7b

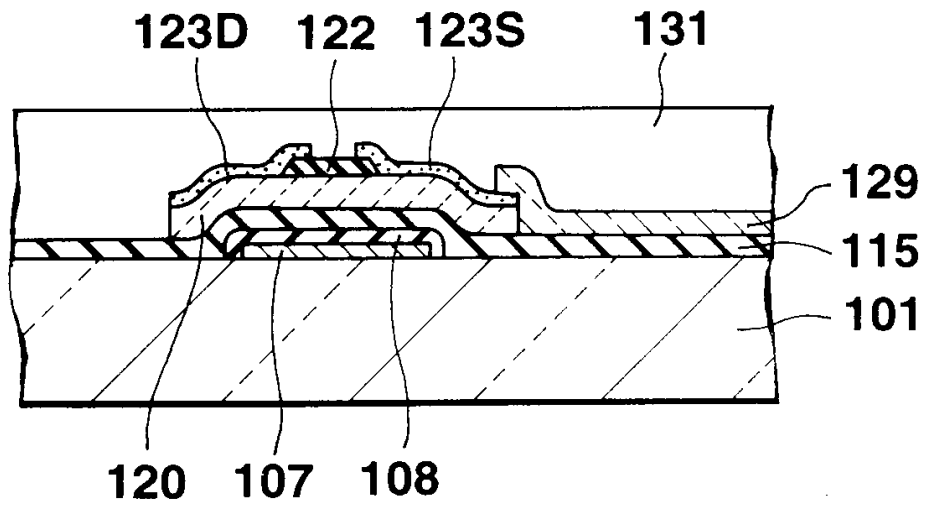
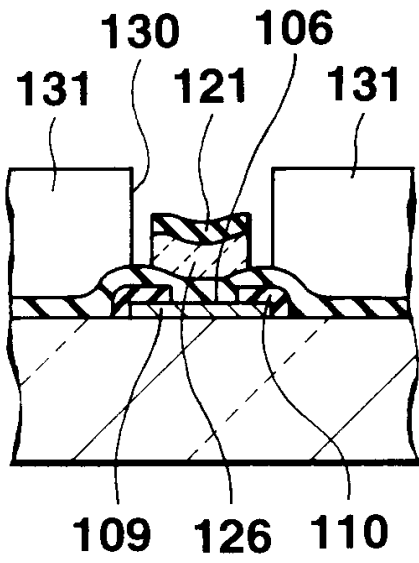

8

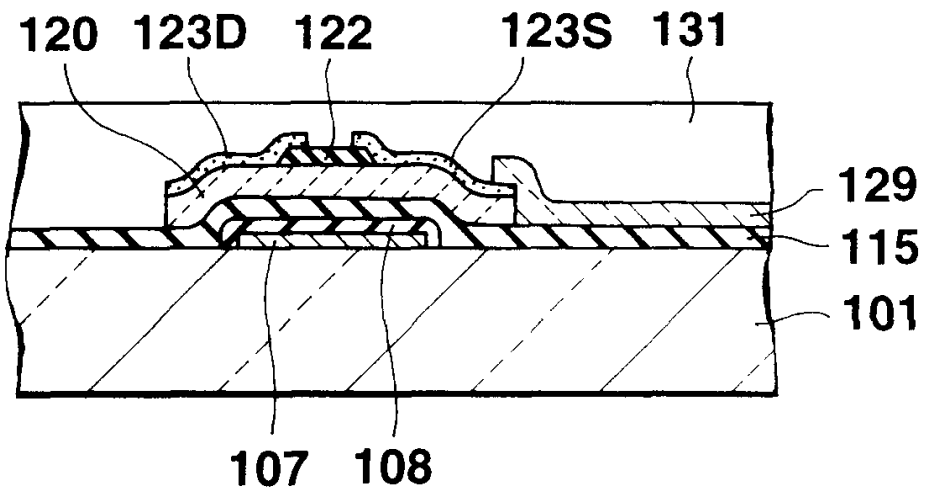
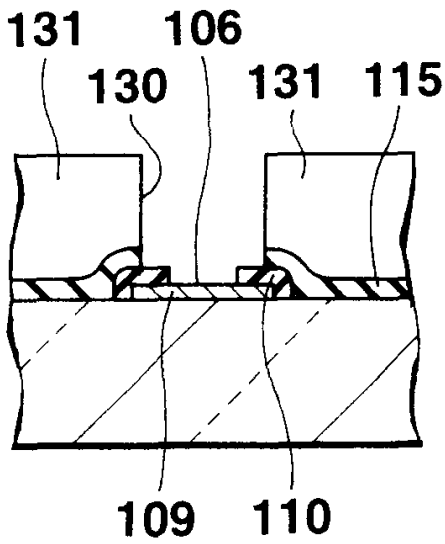

9

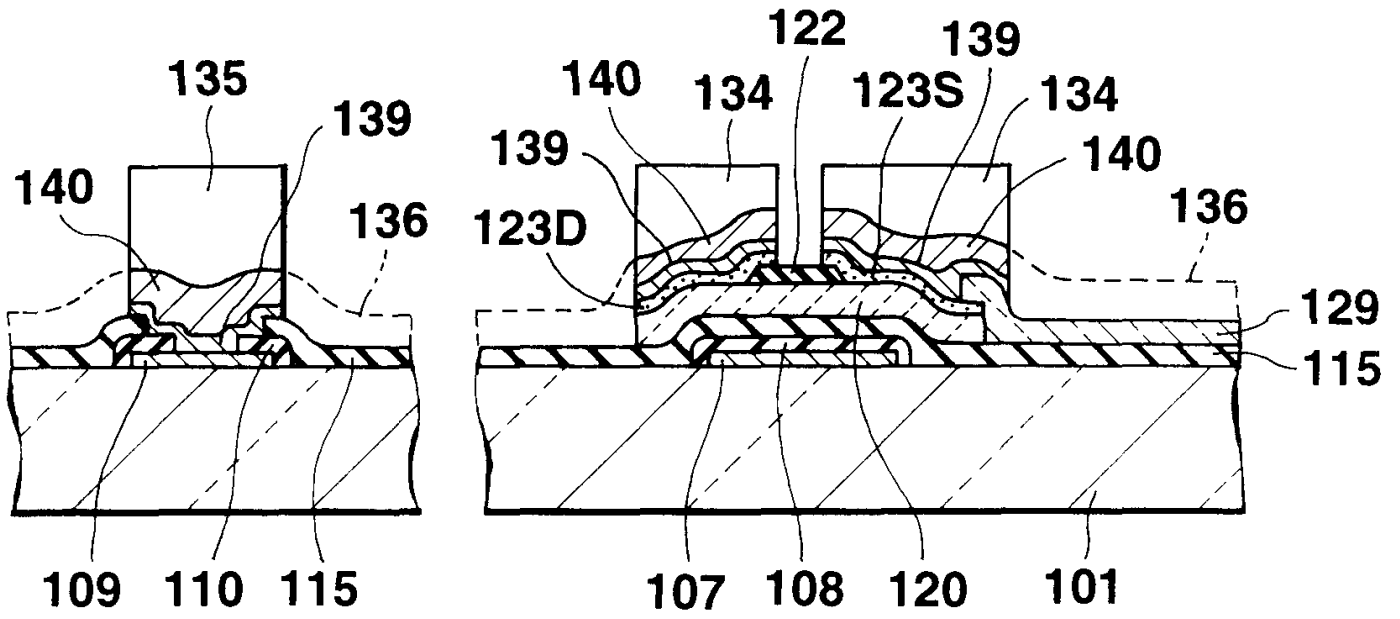

10a

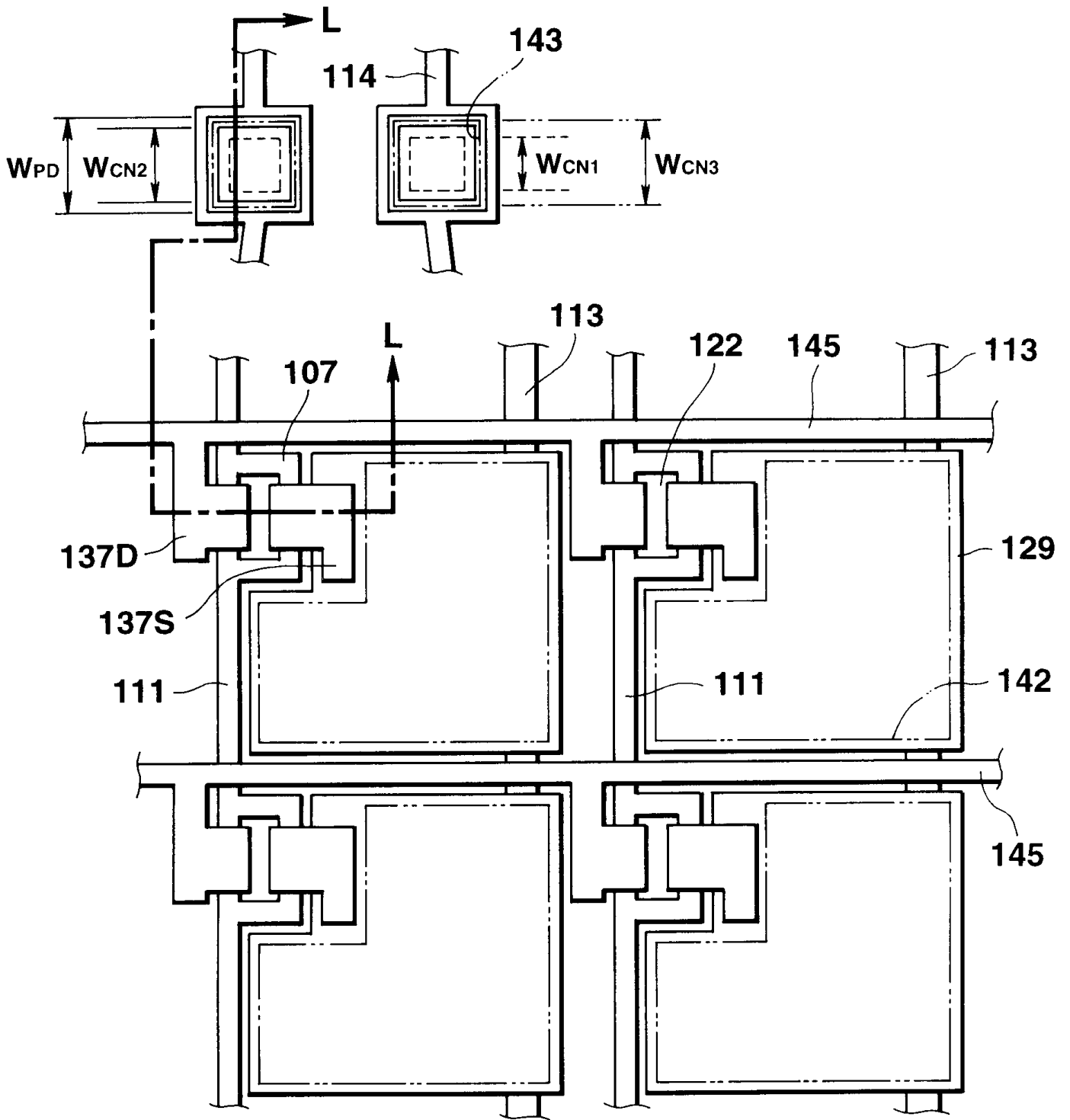

10b

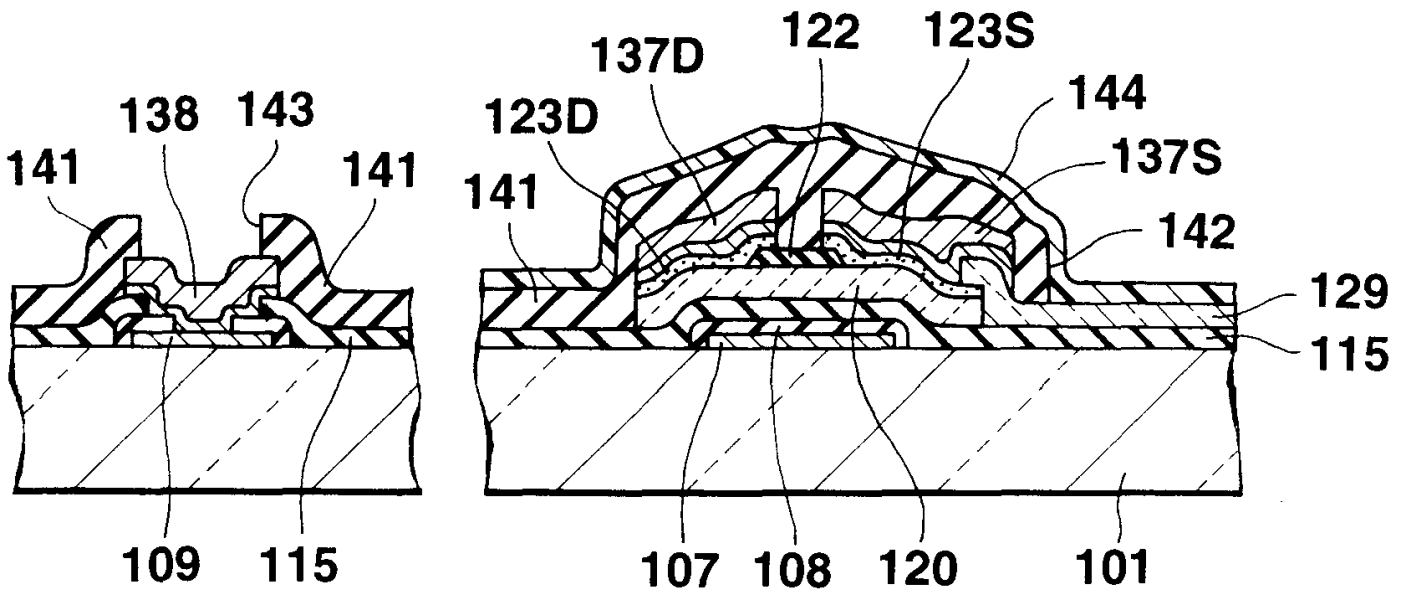

11

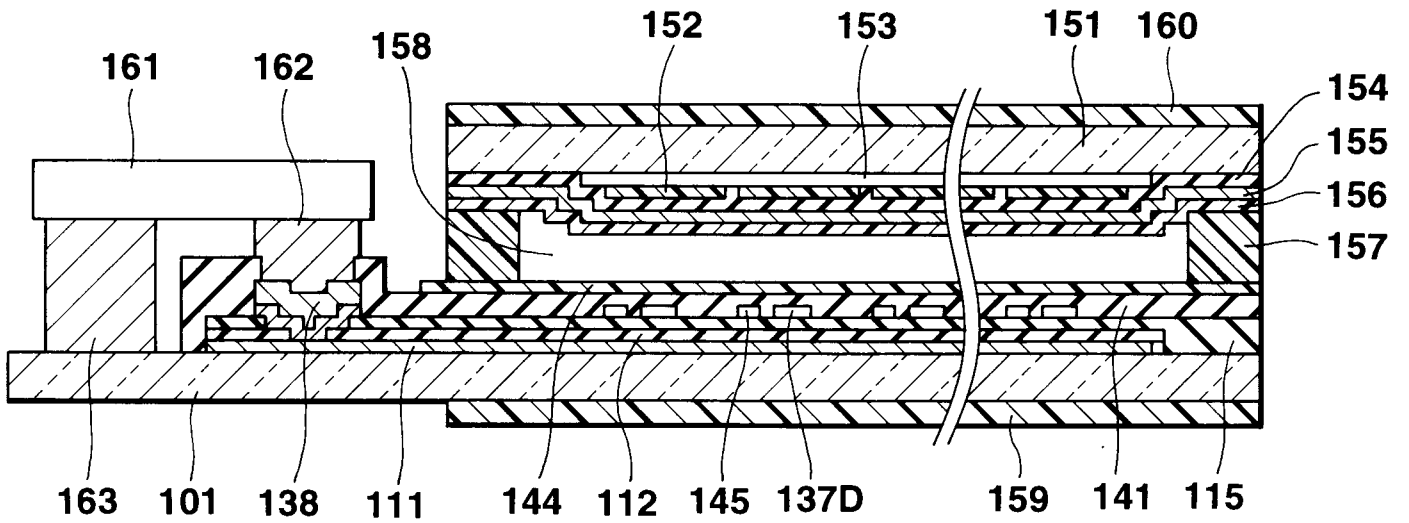

12

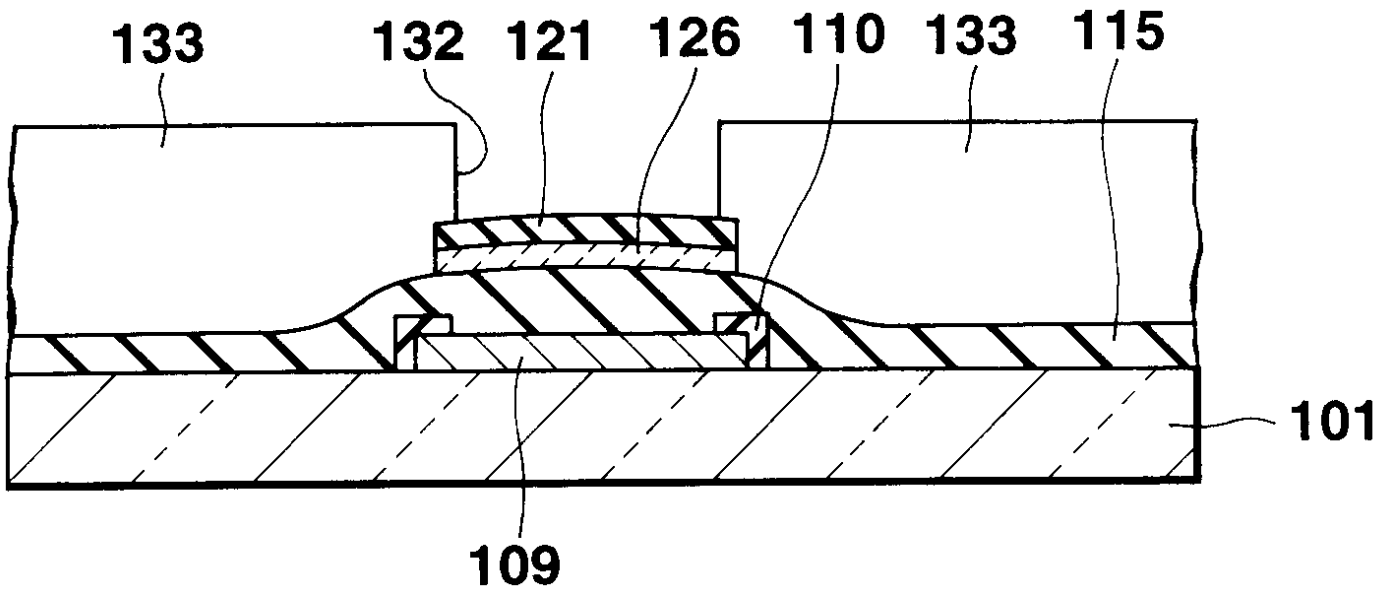

13

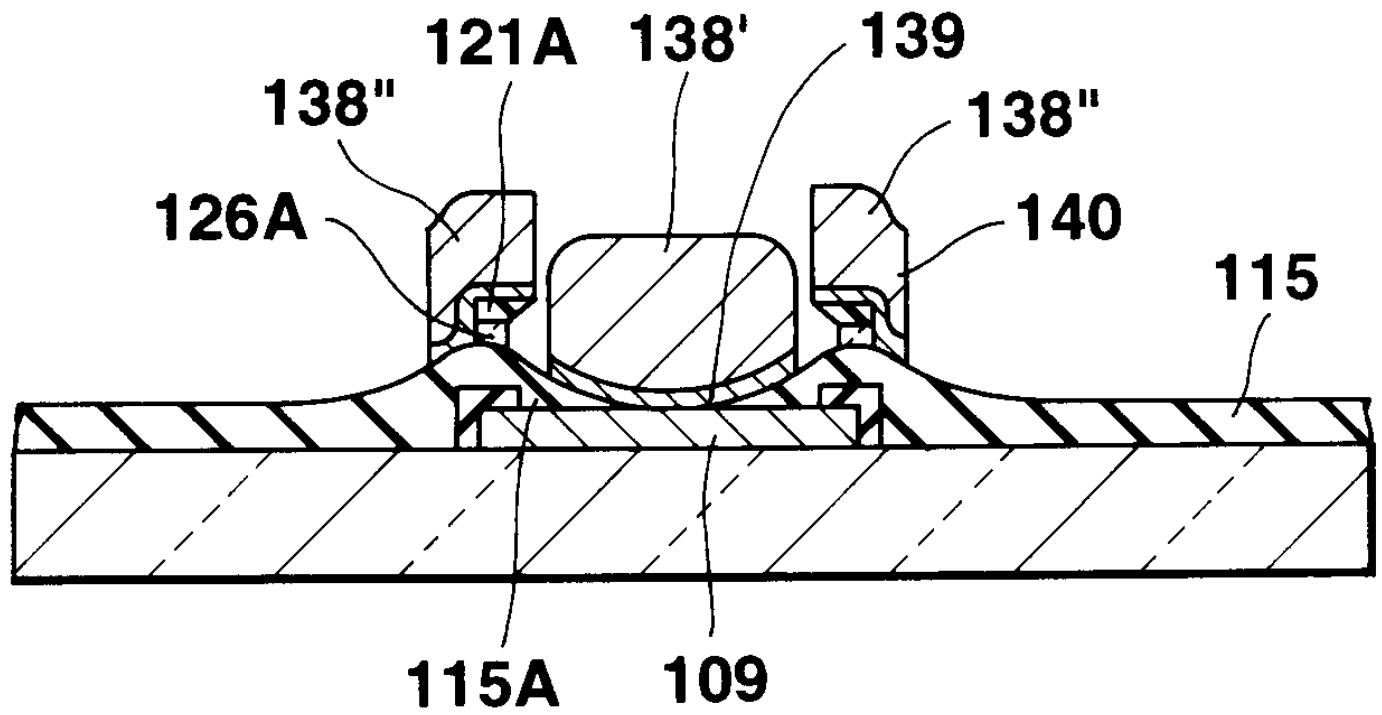

14

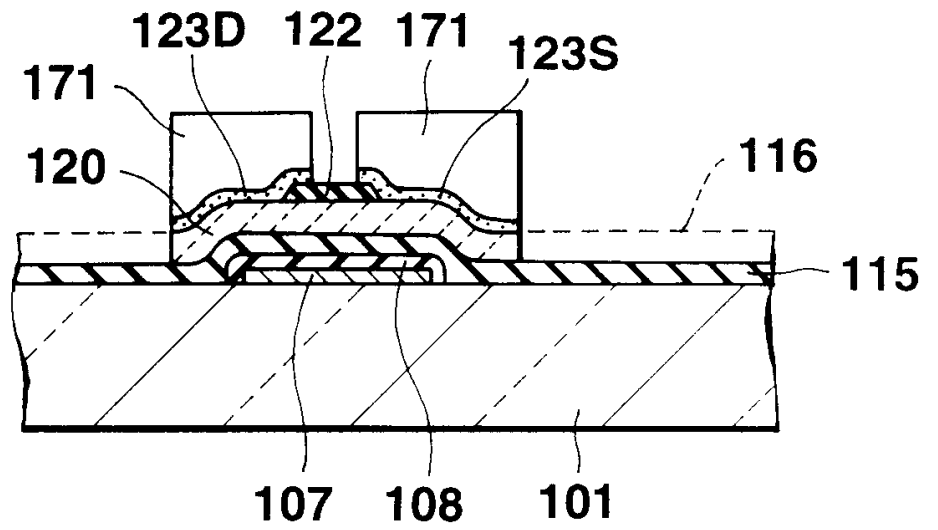
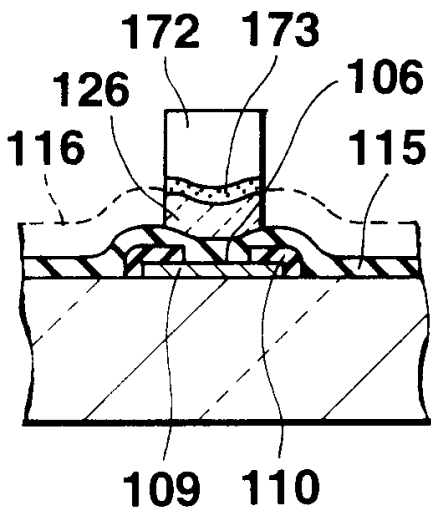

15

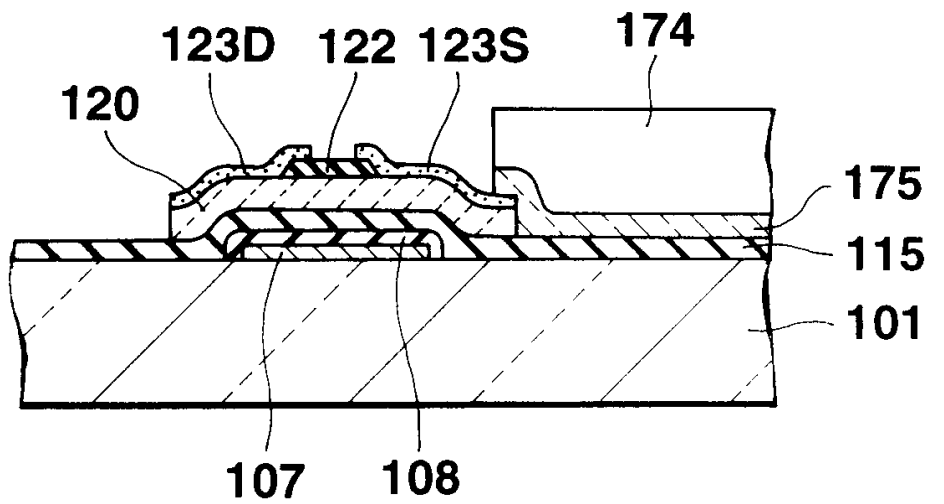
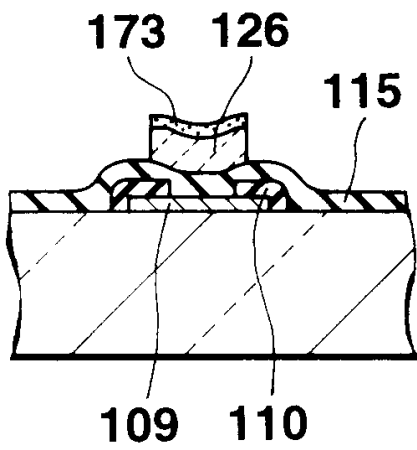

16

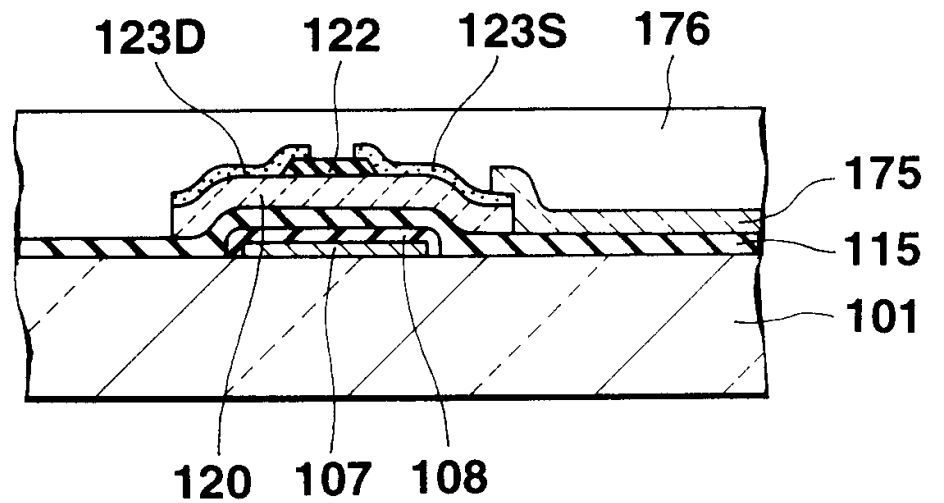
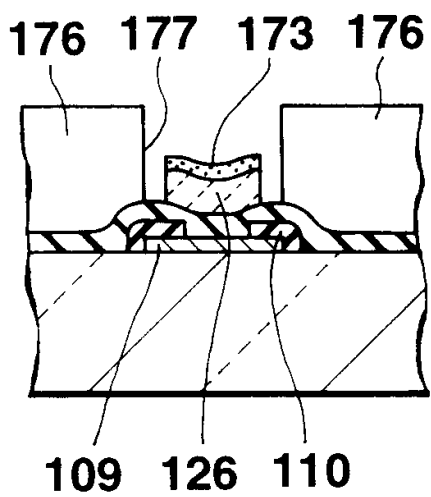

17

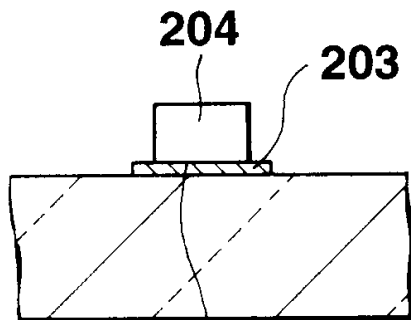

203A

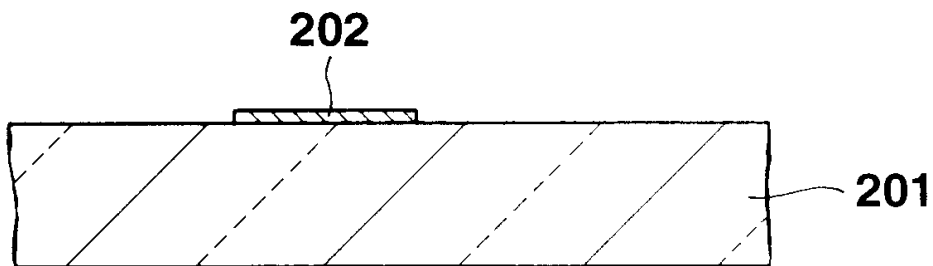

18

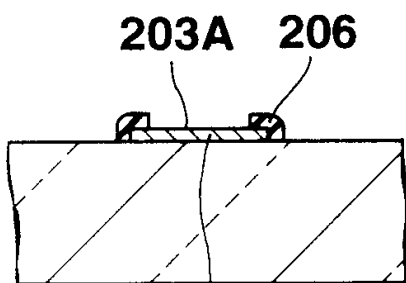

203

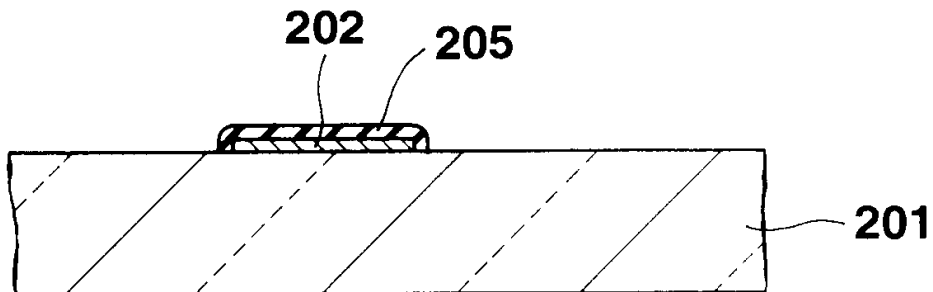

19

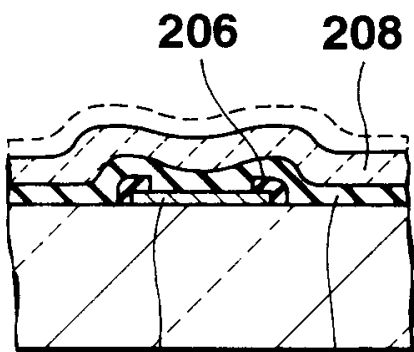

203 207

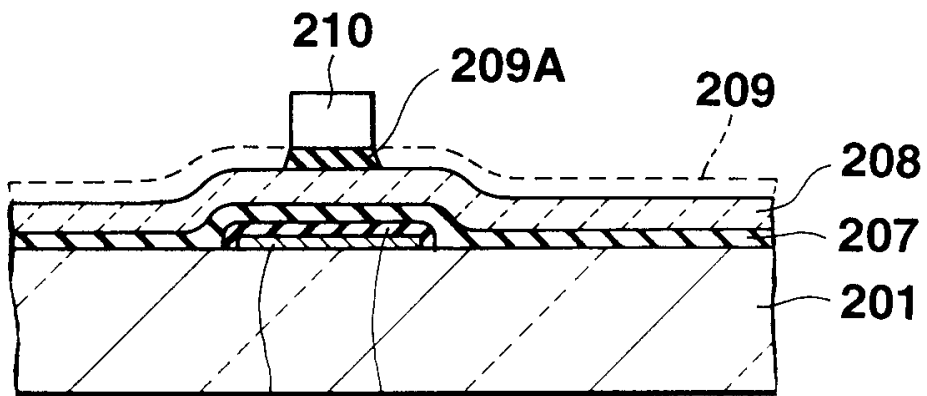

202 205

20

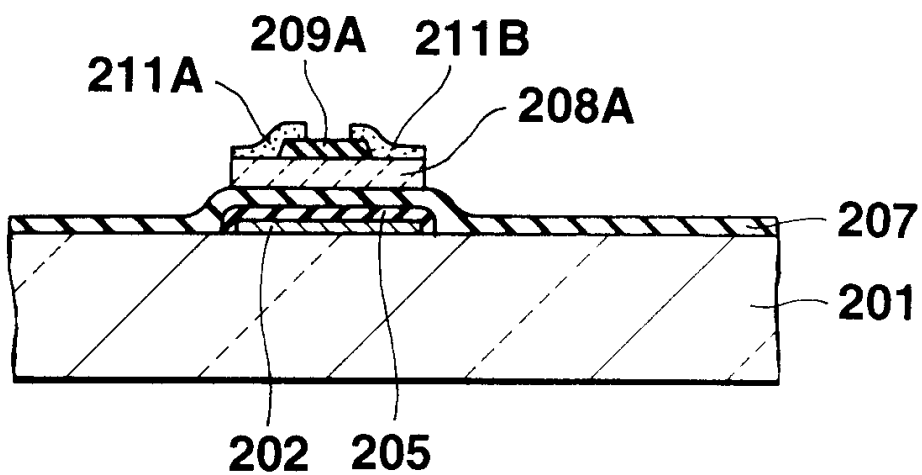
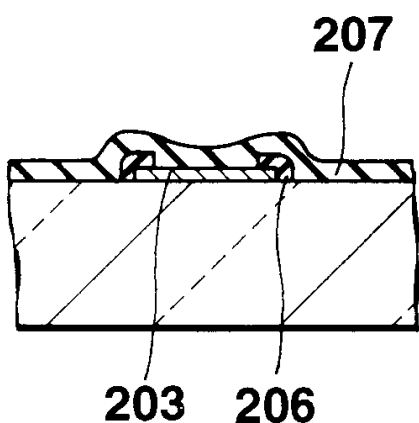

21

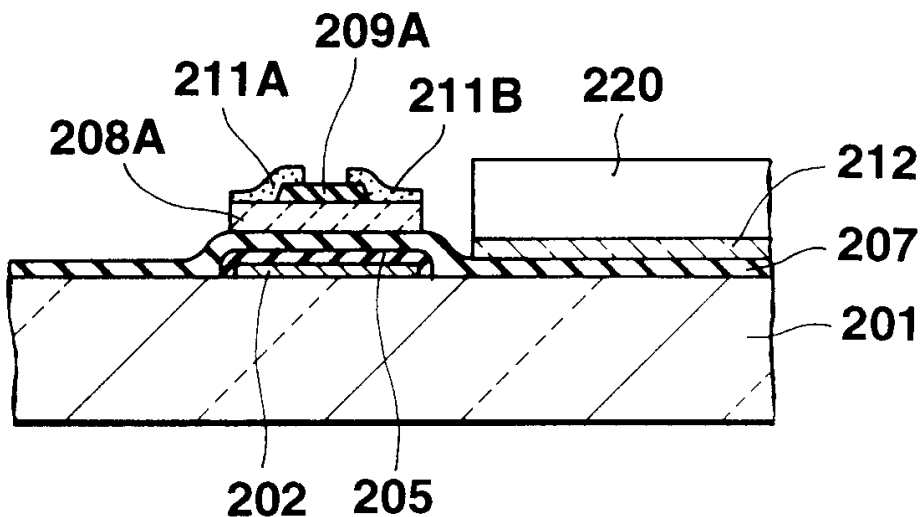
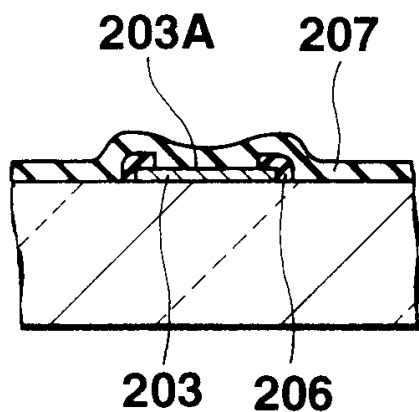

22

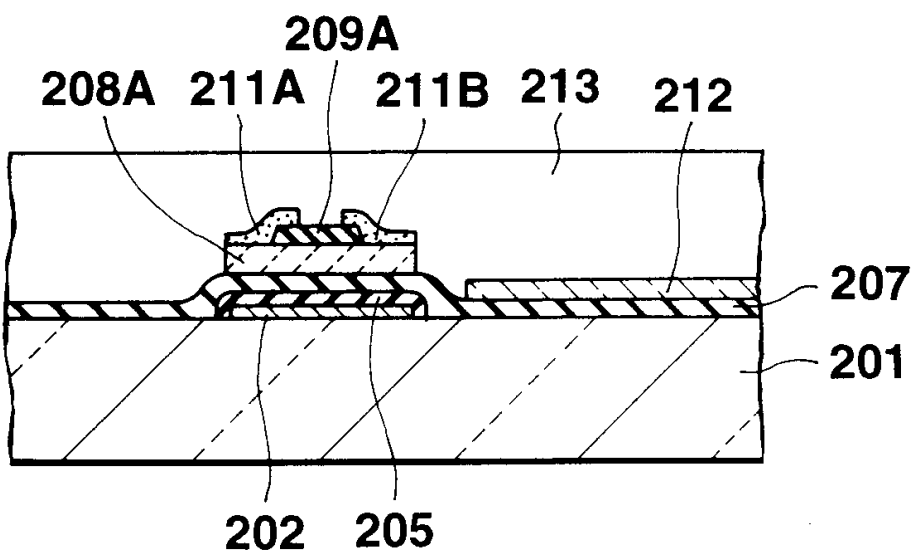
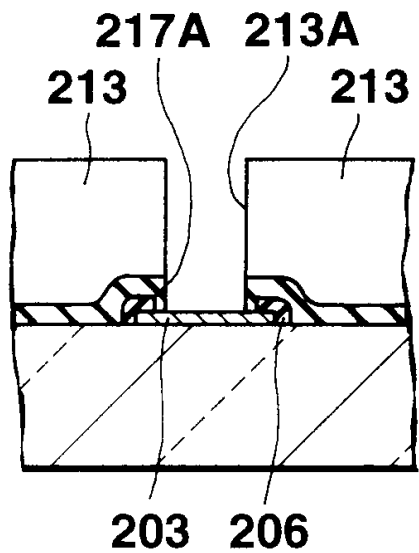

23

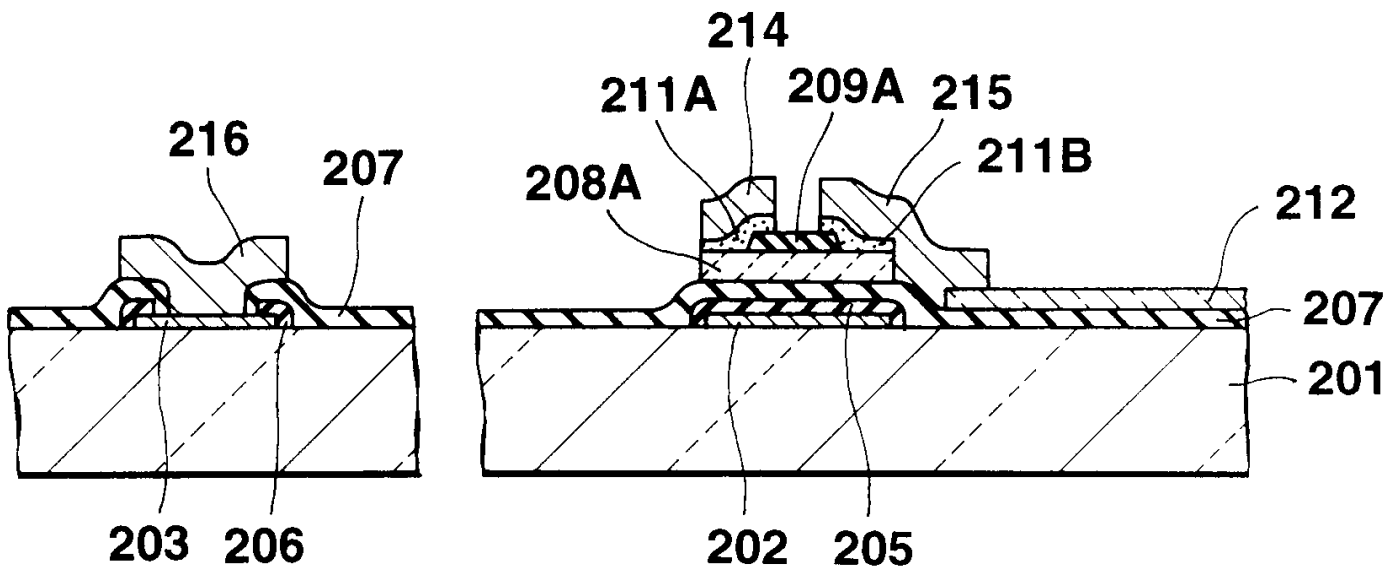

24

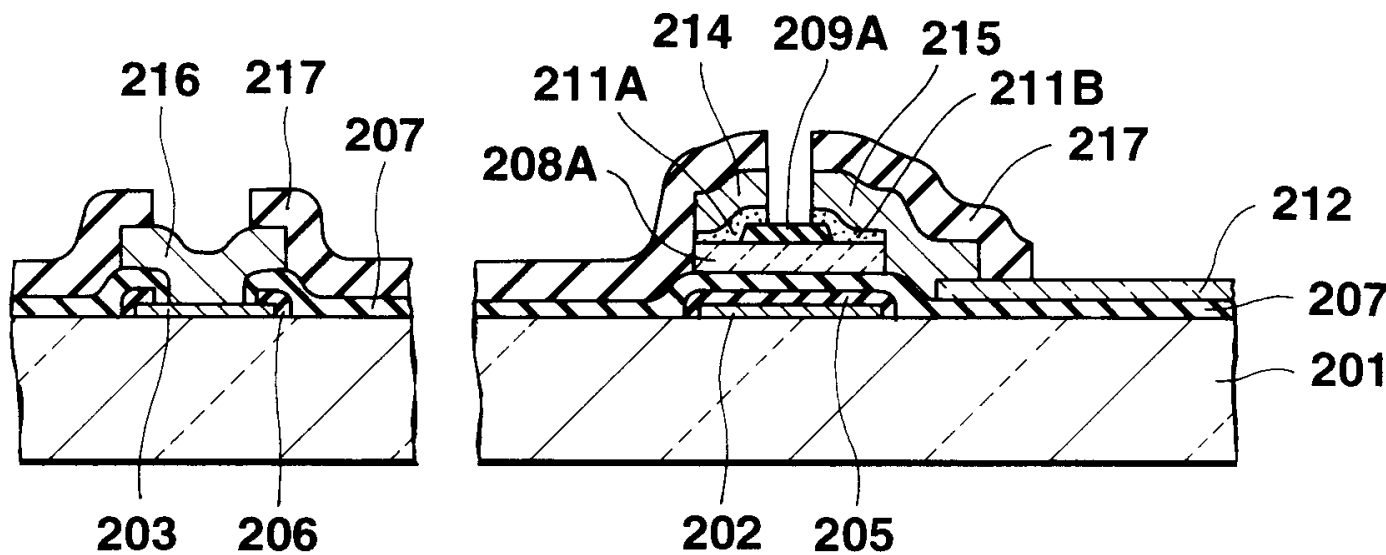

25

