

April 18, 1939.

O. BERMAN

2,155,076

GARMENT

Filed Nov. 24, 1936

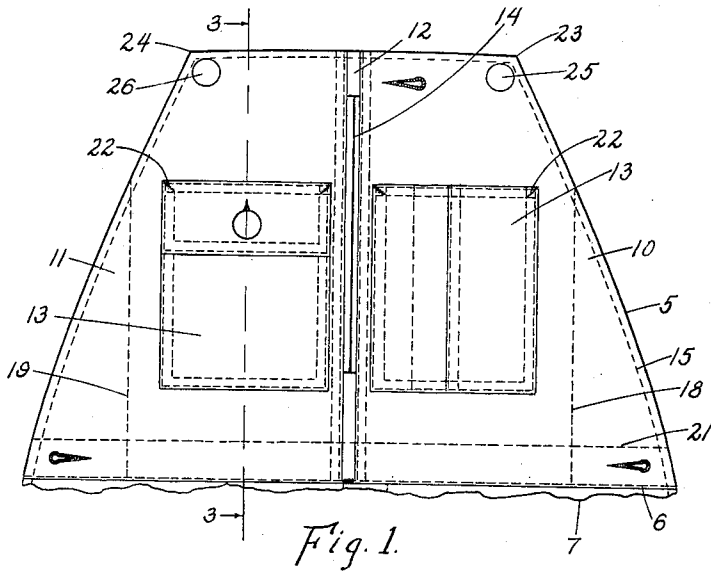

Fig. 1.

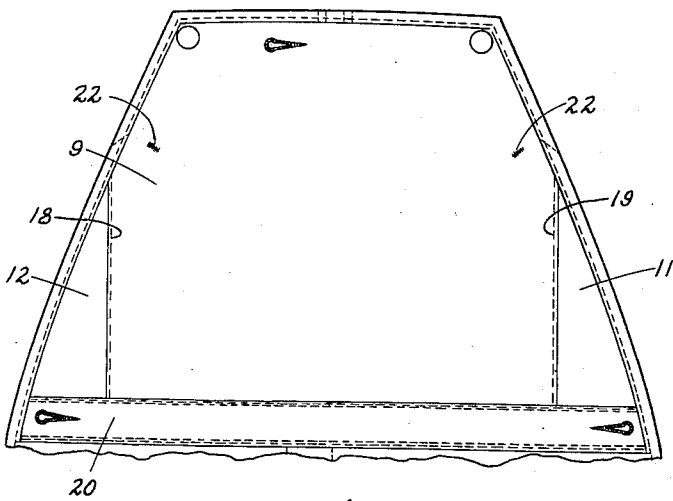

Fig. 2.

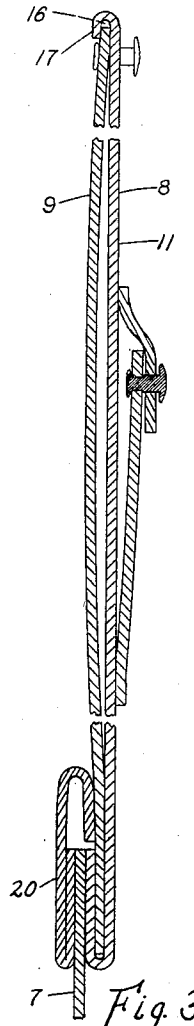

Fig. 3.

OSCAR BERMAN  
INVENTOR.

BY *Frank L. Gugel*  
ATTORNEY.

# UNITED STATES PATENT OFFICE

2,155,076

GARMENT

Oscar Berman, Cincinnati, Ohio

Application November 24, 1936, Serial No. 112,512

3 Claims. (Cl. 2--227)

This invention is concerned with an improvement upon structures of the type disclosed in Hymer Patent 1,205,639.

5 An object of the invention is to provide, by means of a simple arrangement of parts, a garment structure having a large protected pocket, to which ready access may be had, and which will require a minimum of additional fabric and labor to produce.

10 Another object is to provide a garment wherein the pocket forming means serves to provide a stronger bib portion, to provide a better fit of the garment, to better hold the shape of the garment and also to function as a button reinforcement.

15 Another object is to provide an arrangement of parts for attaining the foregoing objectives, and at the same time facilitate forming and assembling of various parts constituting the finished garment.

20 Another object is to provide adequate reinforcement of button carrying parts of the garment without resorting to the tedious attachment of small reinforcing pieces as have been commonly used.

25 The invention is disclosed herein as embodied in the bib of a pair of overalls, however, the invention is not limited to application to work garments or overalls.

30 The foregoing and other objectives are attained by the means described herein and disclosed in the accompanying drawing, in which:

35 Fig. 1 is a fragmental view of the front of a bib portion of a pair of overalls, embodying the invention.

Fig. 2 is a rear view of the device shown in Fig. 1.

40 Fig. 3 is an enlarged sectional view on line 3-3 of Fig. 1, the rows of stitching being omitted.

45 The bib portion 5 is attached by a row of stitching 6, to the leg or trouser portion 7 of a pair of overalls. The bib comprises a front 8 and a back 9. The front comprises lateral sections 10 and 11 and a central section 12. The lateral portions 10 may be fabricated by one or more persons and may be completed by mounting thereon of suitable top patches for forming suitable pockets 13. In like manner similar lateral portions 11 may be made and completed with similar pockets 13. The central sections 12 may likewise be completed independently of the lateral sections. The central section is provided with an elongated vertical slit or central opening which may be equipped with closure

means. The closure means are preferably of the so-called "Zipper" type of fastener shown in Sundback Patent 1,219,881. In the drawing the line shown at 14 is intended to represent the said slit and fastener means. The outer edges of the lateral sections are turned back and secured by a peripheral row of stitching 15. The top and upper lateral edges of the back 9 extend into the fold 16 formed by turning back of the top and upper lateral edges 17 of the lateral sections 10 and 11. The lower side or lateral edges of the back 9 are secured to the rear of the front 8 by stitching 18 and 19 and the lower edge of the back is attached to the front and to the belt or waist portion 20 of the garment by a row of stitching 21. If desired, diagonal rows of stitching 22 may be provided at the upper edges of the pockets and such stitching may be extended through the back 9, as shown, for reinforcing the connection between the lateral front sections and the back, adjacent the lines or rows of stitching 15, 18 and 19.

Attention is directed to the fact that by so relating the lateral front and back sections, a substantial structure is provided at the upper corners 23 and 24 of the bib, and thus is provided substantial anchorage for the buttons 25 and 26, without resorting to the affixation of separate, smaller reinforcing patches at such corners as has been common practice. Thus, there is avoided a tendency toward the formation of heavy humps or lumps of material at the indicated corners, loss of time is avoided incident to attachment of small pieces of fabric at those corners, and moreover, the large back 9, serves to not only form a wall for a large pocket within the bib, but also serves to support the trouser portion of the garment and to distribute and equalize the strain that otherwise would be directed solely upon the front of the bib. By so distributing the strain and weight of the trousers and the contents of the pockets thereof, the garment as a whole is retained in better fitted and more comfortable position upon the wearer.

45 What is claimed is:

1. The combination with a nether garment and a waist portion thereof, of a bib secured to and extending upwardly from the waist portion, said bib comprising a front and a back of equal dimensions vertically, each of which has its lower edge secured to the waist portion, the front tapering upwardly and the back being of a width intermediate the lengths of the upper and lower edges of the front and having its lower side edges secured to the front intermediate the lateral

edges of the front, means securing the upper side and top edges of the back to the top and adjacent peripheral edges of the front with equal lengths of material of the front and back included between said securing means and the waist portion of the garment, and suspender buttons for the garment said suspender buttons each being secured to both the front and back at the lateral and topmost portions thereof, close to a corner where the upper side edge of the back meets the top edge thereof, the front having a substantially central vertical slit providing access to a pocket formed between the front and back.

2. An overall garment which comprises in combination; a bib having a waist portion and a nether portion suspended from the waist portion at the lower edge of the bib, the bib comprising a front having upper corners and a long and narrow central section slitted longitudinally intermediate the longitudinal edges of said section to provide a pocket opening, and comprising further a pair of opposed lateral sections each including a tapered outer edge, a lower edge, an upper edge, and an inner edge, said inner edges of the lateral sections being fixed to the longitudinal edges of the central section at opposite sides of the slit therein, and a back for the bib comprising a sheet of pocket material of a length corresponding to the length of the bib, and having an upper edge coextensive in length with the upper edge of the bib and secured thereto along said upper edge from one corner to the other of the bib, said back including opposed outer edges having limited tapered portions coinciding with corresponding portions of the tapered outer edges of the bib from the corners downwardly, stitching securing the bib

and the back together from the corners downwardly along said tapered coinciding edges, thence along the remaining portions of the opposed outer edges of the back to meet the waist portion of the bib, and a garment suspending means at each upper corner of the bib, each suspending means securing the bib and the back together at the upper extremities of said stitching.

3. An overall garment which comprises in combination; a bib and a nether portion suspended from the lower edge of the bib, the bib comprising a front having upper corners and a long and narrow central section slitted longitudinally intermediate the longitudinal edges of said section to provide a pocket opening, and comprising further a pair of opposed lateral sections each including an outer edge, a lower edge, an upper edge, and an inner edge, said inner edges of the lateral sections being fixed to the longitudinal edges of the central section at opposite sides of the slit therein, a back for the bib comprising a sheet of pocket material having an upper edge coextensive in length with the upper edge of the bib and secured thereto, said back including opposed outer edges substantially coinciding for a limited distance with the outer edges of the bib from the corners at the upper edge of the bib downwardly, garment suspending means located at the upper ends of said coinciding edges where said edges meet the upper edge of the bib, and stitching securing the bib and the back together extending along said coinciding edges of the bib and back from the corner thence along the remaining portions of the outer edges of the back to meet the lower edge of the bib.

OSCAR BERMAN.