

(19) World Intellectual Property
Organization
International Bureau



(43) International Publication Date
21 April 2005 (21.04.2005)

PCT

(10) International Publication Number
WO 2005/034667 A1

- (51) International Patent Classification⁷: **A42B 3/32** **Peter** [GB/GB]; 60 Telscombe Way, Stopsley, Luton, Bedfordshire LU2 8JW (GB). **GOULDTHORPE, Martin** [GB/GB]; 27 Parklands, Royston, Hertfordshire SG8 9HL (GB).
- (21) International Application Number: PCT/GB2004/004290
- (22) International Filing Date: 7 October 2004 (07.10.2004) (74) Agents: **MOIR, Michael, Christopher** et al.; Mathys & Squire, 120 Holborn, London EC1N 2SQ (GB).
- (25) Filing Language: English (81) Designated States (unless otherwise indicated, for every kind of national protection available): AE, AG, AL, AM, AT, AU, AZ, BA, BB, BG, BR, BW, BY, BZ, CA, CH, CN, CO, CR, CU, CZ, DE, DK, DM, DZ, EC, EE, EG, ES, FI, GB, GD, GE, GH, GM, HR, HU, ID, IL, IN, IS, JP, KE, KG, KP, KR, KZ, LC, LK, LR, LS, LT, LU, LV, MA, MD, MG, MK, MN, MW, MX, MZ, NA, NI, NO, NZ, OM, PG, PH, PL, PT, RO, RU, SC, SD, SE, SG, SK, SL, SY, TJ, TM, TN, TR, TT, TZ, UA, UG, US, UZ, VC, VN, YU, ZA, ZM, ZW.
- (26) Publication Language: English
- (30) Priority Data: 0323437.4 7 October 2003 (07.10.2003) GB
- (71) Applicant (for all designated States except US): **HELMET INTEGRATED SYSTEMS LIMITED** [GB/GB]; Unit 3, Focus 4, Fourth Avenue, Letchworth, Hertfordshire SG6 2TU (GB).
- (72) Inventors; and (84) Designated States (unless otherwise indicated, for every kind of regional protection available): ARIPO (BW, GH, ZW).
- (75) Inventors/Applicants (for US only): **SMITH, Simon,**

[Continued on next page]

(54) Title: PROTECTIVE HELMET

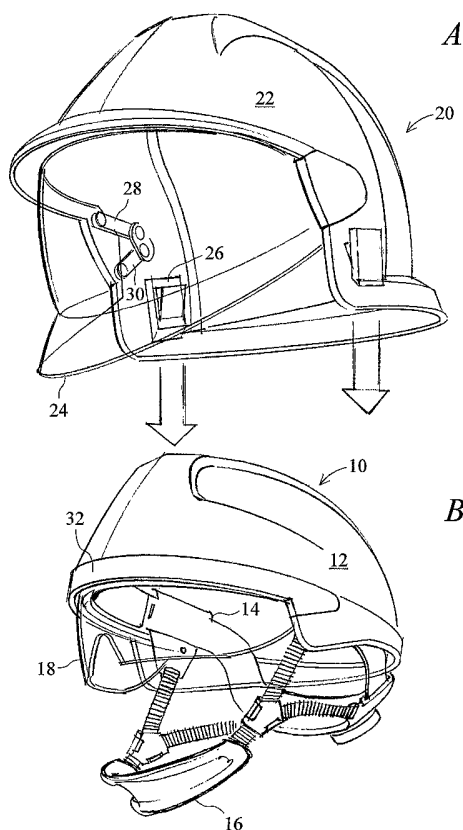

(57) Abstract: A firefighter's helmet comprising an inner protective shell configured to be worn on its own as a helmet and an outer protective shell configured to be fitted over the inner shell and realisably retained thereon, comprising retaining mechanism for retaining the inner shell in the outer shell, wherein the retaining mechanism is moveable by a user whilst wearing the inner shell between a first position in which the retaining mechanism engages a said shell substantially to prevent relative movement between the two shells; and a second position in which the retaining mechanism permits relative movement of the shells whereby allowing the donning or doffing of the outer shell by the user.

WO 2005/034667 A1



GM, KE, LS, MW, MZ, NA, SD, SL, SZ, TZ, UG, ZM, ZW), Eurasian (AM, AZ, BY, KG, KZ, MD, RU, TJ, TM), European (AT, BE, BG, CH, CY, CZ, DE, DK, EE, ES, FI, FR, GB, GR, HU, IE, IT, LU, MC, NL, PL, PT, RO, SE, SI, SK, TR), OAPI (BF, BJ, CF, CG, CI, CM, GA, GN, GQ, GW, ML, MR, NE, SN, TD, TG).

Published:

— *with international search report*

For two-letter codes and other abbreviations, refer to the "Guidance Notes on Codes and Abbreviations" appearing at the beginning of each regular issue of the PCT Gazette.

Protective Helmet

The present invention relates to protective helmets, and in particular to firefighters' helmets.

5

Existing firefighters' helmets comprise a protective outer shell made from impact-resistant plastics or the like which is intended to protect the wearer from falling debris which often is a hazard of burning buildings. To protect the wearer also from the heat and sparks emitted from a fire, the helmet includes a visor and neck protector to
10 protect the head, face and neck of the wearer.

There are cases where the full protective effect of a firefighting helmet is not required. For example, firefighters may have to provide a rescue service at other emergencies in which there is no fire. Then a large firefighting helmet may be
15 inconvenient, but head protection is still necessary. In particular, in the case of road traffic accidents, when a firefighter may need to work in a confined space eg. Within a damaged vehicle, the large helmet may be an impediment. In these cases, it is often found that firefighters will simply remove their helmets, exposing themselves to unnecessary danger. The preferred embodiments of this invention seek to provide a
20 solution to this problem.

Although some two-layer helmets have been proposed to solve this problem it is awkward to both fit the inner and outer helmets on the wearers head securely and provide a wearer friendly mechanism for disengaging the outer helmet.

25

According to this invention there is provided a firefighters helmet comprising an inner protective shell configured to be worn on its own as a helmet, and an outer protective shell configured to be fitted over the inner shell and releasably retained thereon, comprising a retaining mechanism for retaining the inner shell in the outer shell,
30 wherein the retaining mechanism is moveable by a user whilst wearing the inner shell between a first position in which the retaining mechanism engages a said shell substantially to prevent relative movement between the two shells and a second position in which the retaining mechanism permits relative movement of the shells whereby allowing the donning or doffing of the outer shell by the users.

Preferably the outer shell has an outwardly extending brim or cape.

The helmet may comprise a spacer for spacing the outer shell from the inner shell.
The helmet may comprise a visor which is accommodated between the inner and
5 outer shells when not in use.

The retaining mechanism may be releasably biased towards the first position.
Preferably the retaining mechanism is moveable by a user whilst wearing the inner
shell in order to move it from the first to the second position for allowing the
10 introduction or removal of the outer shell onto or off the inner shell. The retaining
mechanism may be pivotally connected to the helmet. The retaining mechanism
may be pivotally mounted to an attachment mechanism which is connected to the
outer shell, the retaining mechanism thereby being spaced from the outer shell.

15 The inner helmet may comprise a slot which is engageable by the attachment
mechanism such that when the retaining mechanism is in the second position the
attachment mechanism can be moved through the slot whilst when the retaining
mechanism is in the first position the attachment mechanism cannot be moved
through the slot. The retaining mechanism may engage a lower edge of the slot
20 whilst in the first position.

The attachment mechanism may comprise a mounting for an accessory to the
helmet.

25 The retaining mechanism may be disposed on the outer shell, in which case it may
engage a lower edge of the inner shell.

A helmet as described above may comprise a mounting for attaching at least one
accessory to the helmet.

30

Embodiments of the invention are now described purely by way of example and with
reference to the following figures:

Figure 1A shows the outer helmet;

Figure 1B shows the inner helmet;

Figures 2A and 2B show front and side views of the helmet shells assembled together;

Figure 3 shows an inside view of the inner shell locked into the outer helmet shell;

Figures 4 to 7 show outer helmet shells with provision for various detachable accessories and ancillary equipment;

Figure 8 shows schematically an exploded view of a second embodiment of an outer helmet and an inner helmet, having a different attachment mechanism from that of Figures 1 to 3;

Figure 9 shows schematically a side perspective view of the attachment mechanism for securing the helmets shown in Figure 8;

Figure 10 shows schematically a front view of the attachment mechanism of Fig 9;

Figure 11 shows schematically the helmets being attached together;

Figure 12 shows schematically the attachment mechanism in a locked position; and

Figure 13 shows schematically the attachment mechanism in an unlocked position.

Figures 1A and B show a firefighter's helmet comprising separate inner and outer shells. The inner shell of Figure 1B (generally denoted as 10) is wearable on its own as an impact-resisting helmet. It comprises an outer protective moulding 12 of glass fibre-reinforced plastics or other impact-resisting plastics within which is a further impact resisting layer as known per se. The shell 10 is worn by the user by mechanism of a net cap or liner having a headband 14 and chinstrap 16. There is also an ocular protector 18 to protect the firefighter's eyes when only the inner shell is being worn. The outer shell of Figure 1A (generally denoted as 20) comprises a protective moulding 22 of glass fibre reinforced plastics or other impact-resisting plastics material. It has a large enough interior to accommodate the inner shell 10. It also has retaining clips 26 to hold the outer shell onto the inner shell. The outer shell has a full visor 24 to protect the firefighter's face from flying debris and from radiant heat. The visor 24 is pivotally mounted at the sides of the outer shell 20 by mechanism of links 28, 30 pivotally connected to the moulding 22 and the visor 24. Together with the distances between the pivots on the visor and between the pivots on the moulding, the links 28, 30 form a four-bar linkage which enables the visor to move between a deployed position in which it covers the wearer's face, and a stowed position (fig. 2B) in which it is retracted between the inner and outer shells. The use of a four-bar linkage enables the relatively large visor 24 to move along a path close

to the surface of the inner helmet. Thereby the outer shell can fit compactly over it. The ocular shield 18 may also be pivotable on a four-bar linkage for storage within the inner shell. However because the shield is shallower, a single-point pivot may suffice.

5

As can be seen from the arrows linking Figures 1A and 1B, the outer shell is fitted over the inner shell and the retaining clips 26 lock the shells together. The shells in their locked-together state are shown in Figures 2A and 2B. Figure 2A shows a front view of the shells when locked together. The figure shows the outer shell 20 in section and the inner shell 10 in full. Figure 2B shows a side view of the shells locked together with the visor 24 of the outer shell 20 in a stowed position between the two shells (10,20).

10

The rim 32 of the inner shell 12 engages pads (not shown) on the inner surface of the outer shell 22 around the greater part of its circumference, except at the front where a gap is provided to permit the passage of the visor 24. A further pad or pads (not shown) is provided in the comb 34 so that when the outer shell is pulled down on to the inner shell and the retaining clip 26 engaged the outer shell is firmly located on the inner shell with a gap of approximately 6mm between them.

15

Referring to figure 3, each retaining clip 26 is disposed in a housing 27 and biased outwardly by a spring (not shown). The clip 26 can be pressed into its housing 27 in order to allow the inner helmet 10 to slide past the clip 26 into the outer helmet 20. The clip 26 is tapered in such a way that the sliding of the outer helmet onto the inner helmet has the effect of pressing the clip in so that it does not need to be pressed-in manually when the helmets are fully together, the spring returns the clip 26 to a protruding position to hold the shells in place. The orientation of the shells can be seen via the relative positioning of the ocular protector 18 and the visor 24 (which are aligned with each other).

20

25

Also visible in figure 3 is a net cap 34 forming the suspension of the helmet on the wearer's head. The net 34 is adjustable as known per se to fit the helmet comfortably to the wearer's head in the correct position. In particular an adjustable nape pad 36 in combination with the chin strap 16 and an adjustable forehead pad 38 locates the

30

helmet-fore-and-aft so that the ocular shield 18 and the visor 24 are properly positioned.

5 Figure 4 shows an embodiment of the helmet which has a slot 40 for mounting breathing apparatus, and an external lever 41 for moving the visor 24 between its stowed and deployed positions. Alternatively, if the bottom edge of the visor 24 projects from the outer shell when stowed so as to be graspable by a firefighter's gloved hand, the lever 41 can be omitted.

10 Figure 5 shows a neck curtain 42 attached to the outer shell 20, to provide additional protection against falling ash or embers.

Figure 6 shows an embodiment of the helmet which has a mounting for a torch 44.

15 Figure 7 shows a fold out hook loop 46 of the outer shell of the helmet in use to hang the helmet.

Provision may instead or in addition be made on the inner helmet for mounting accessories, and though it may not be possible to fit the outer helmet over it when
20 the accessories are in place.

Figure 8 shows schematically an exploded view of an outer helmet 50, and inner helmet 52 which comprises an inner portion 54, adapted to fit a user's head, and an outer liner 56 to which a visor 58 is attached. An attachment mechanism 60, which
25 connects the inner and outer helmets, is shown in more detail in figures 9 and 10.

The attachment mechanism 60, comprises two main portions: a U shaped housing 62 and a lever 64, which is pivotally mounted on the housing at A. A torsion spring (not shown) connects the lever 64 to the housing 62 and biases the lever 64 in a
30 direction which would be clockwise as seen in figure 9. The torsion spring may, alternatively, be formed in the body of the lever 64, particularly if the lever is of a plastics material.

The lever 64 comprises an upper portion 66 which is generally rectangular, offset

from the midline of, and positioned at a slight angle to a lower portion 68 of the lever 64. The upper portion 66 has a top surface 69. A sloping abutment surface 70 connects one side of the two portions. Due to the biasing of the torsion spring this surface is normally in contact with a raised surface 72 of the leg of the attachment mechanism on which the lever is disposed.

The external surface of the leg of the U-shaped housing 62 opposite the lever 64 is glued to an internal surface of the outer helmet 50. The other leg of the housing may be connected to the inner helmet as follows.

A slot 74, which is slightly wider than the leg of the U-shaped housing on which the lever 64 is disposed, is formed in the inner portion 54 of the inner helmet 52. The slot is approximately 25 mm long and formed midway between the front and rear of the helmet, around halfway up the helmet's side. At the rear of the slot 74 is a solid abutment surface 76, which is as deep as the slot and approximately the same width as the top surface of the lever 64.

To connect the helmets the user inserts the lever 64 into the slot, and pulls the outer helmet 50 in a generally downward direction. Figure 11 shows the two helmets during the attachment process. As the slot moves upwardly relative to the attachment mechanism, past the pivot point of the lever 64, because it is so narrow it forces the lever to pivot anti-clockwise (as seen in figure 9). When the slot moves past the top surface of the lever, its anti-clockwise moment on the lever is released and, biased by the spring, the lever snaps back into a position shown in Figure 12. The top surface of the lever 64 now abuts the solid abutment surface 76 of the slot 74, locking the two helmets together.

If the user should wish to disengage the helmets, she simply rotates the lower portion of the lever anti-clockwise, so that the top surface of the lever is aligned with the slot 74, as shown in Figure 13, and lifts the upper helmet off the lower one.

A second attachment mechanism (not shown) is disposed opposite the first attachment mechanism and is its mirror image, being appropriately biased. Both levers must be engaged or disengaged when donning or doffing the helmet.

Some other features of the attachment mechanism 60 are shown in Figure 10. The attachment mechanism may have two lugs 80 to which the visor 58, and the liner 56 may be attached, in which case the lowest portion of the leg of the housing to which the lugs are attached may be formed as U-shape to provide a stop for the visor 58. A connector 82 for breathing apparatus may be formed on an external surface of the housing.

Each feature disclosed in this specification (which term includes the claims) and/or shown in the drawings may be incorporated in the invention independently of other disclosed and/or illustrated features. Statements in this specification of the "objects of the invention" relate to preferred embodiments of the invention, but not necessarily to all embodiments of the invention falling within the claims. The description of the invention with reference to the drawings is by way of example only.

The text of the abstract filed herewith is hereby deemed to be repeated here in full as part of the specification.

A firefighter's helmet comprises an inner protective shell configured to be worn on its own as a helmet and an outer protective shell configured to be fitted over the inner shell and releasably retained thereon, comprising retaining mechanism for retaining the inner shell in the outer shell, wherein the retaining mechanism is moveable by a user whilst wearing the inner shell between a first position in which the retaining mechanism engages a said shell substantially to prevent relative movement between the two shells; and a second position in which the retaining mechanism permits relative movement of the shells whereby allowing the donning or doffing of the outer shell by the user.

Publish figures 1A and 1B

Claims

1. A firefighter's helmet comprising an inner protective shell configured to be worn on its own as a helmet and an outer protective shell configured to be fitted over the inner shell and releasably retained thereon, comprising retaining mechanism for retaining the inner shell in the outer shell, wherein the retaining mechanism is moveable by a user whilst wearing the inner shell between a first position in which the retaining mechanism engages a said shell substantially to prevent relative movement between the two shells; and a second position in which the retaining mechanism permits relative movement of the shells whereby allowing the donning or doffing of the outer shell by the user.
2. A helmet as claimed in claim 1, wherein the outer shell has an outwardly extending brim or cape.
3. A helmet according to claim 1 or claim 2, comprising a spacer for spacing the outer shell from the inner shell.
4. A helmet according to any of claims 1 to 3, comprising a visor which is accommodated between the inner and outer shells when not in use.
5. A helmet according to any preceding claim, wherein the retaining mechanism is resiliently biased towards the first position.
6. A helmet according to Claim 5 wherein the retaining mechanism is moveable by a user whilst wearing the inner shell in order to move it from the first to the second position for allowing the introduction or removal of the outer shell on to or off the inner shell.
7. A helmet according to any preceding claim wherein the retaining mechanism is pivotally connected to the helmet.

8. A helmet according to Claim 7 wherein the retaining mechanism is pivotally mounted on an attachment mechanism which is connected to the outer shell, the retaining mechanism thereby being spaced from the outer shell.

5

9. A helmet according to Claim 8 wherein the inner helmet comprises a slot, which is engageable by the attachment mechanism such that when the retaining mechanism is in the second position the attachment mechanism can be moved through the slot whilst when the retaining mechanism is in the first position the attachment mechanism cannot be moved through the slot.

10

10. A helmet according to Claim 9 wherein the retaining mechanism engages a lower edge of the slot when in the first position.

15

11. A helmet according to any of claims 8 to 10 wherein the attachment mechanism comprises a mounting for an accessory to the helmet.

12. A helmet according to any of claims 1 to 7, wherein the retaining mechanism is disposed on the outer shell.

20

13. A helmet according to Claim 12, wherein the retaining mechanism engages a lower edge of the inner shell.

14. A helmet according to any preceding claim, comprising a mounting for attaching at least one accessory to the helmet.

25

15. A helmet substantially as herein described with reference to the accompanying drawings.

30

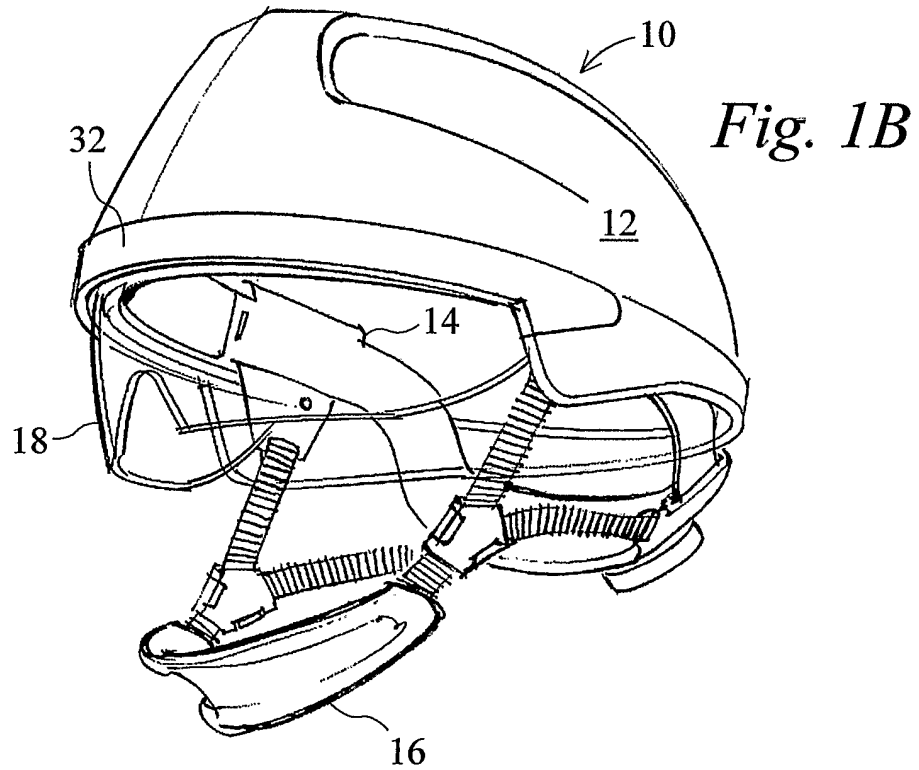
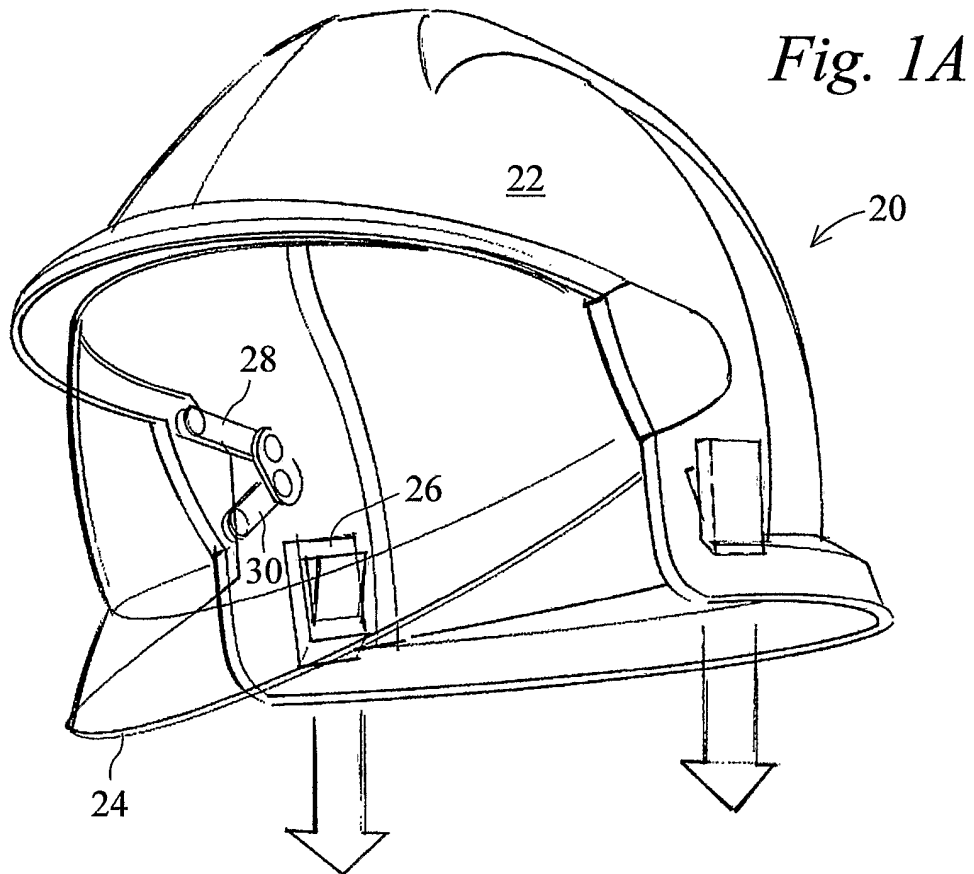

2/11

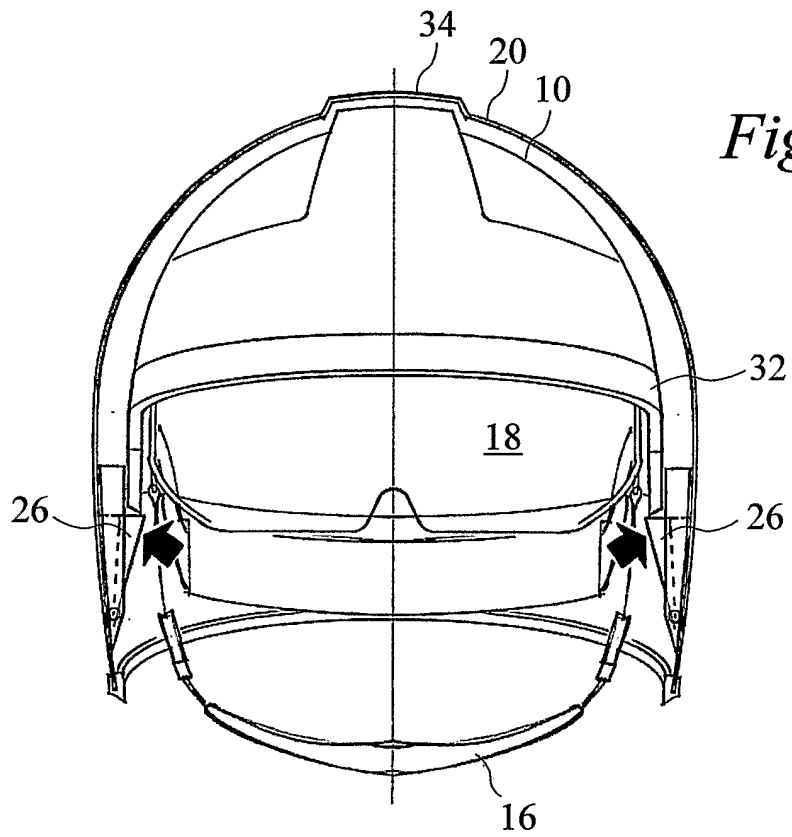

Fig. 2A

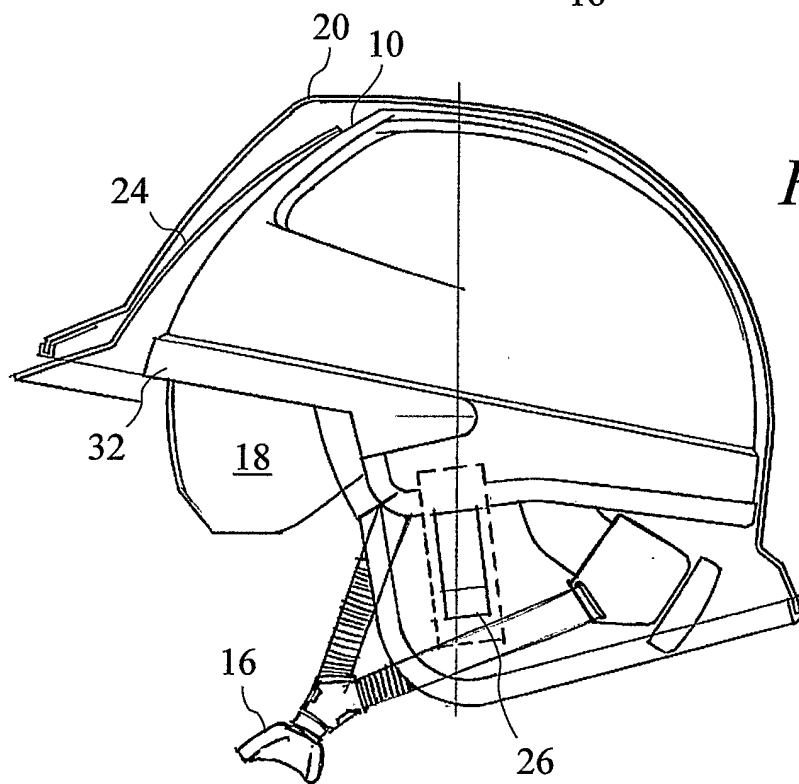

Fig. 2B

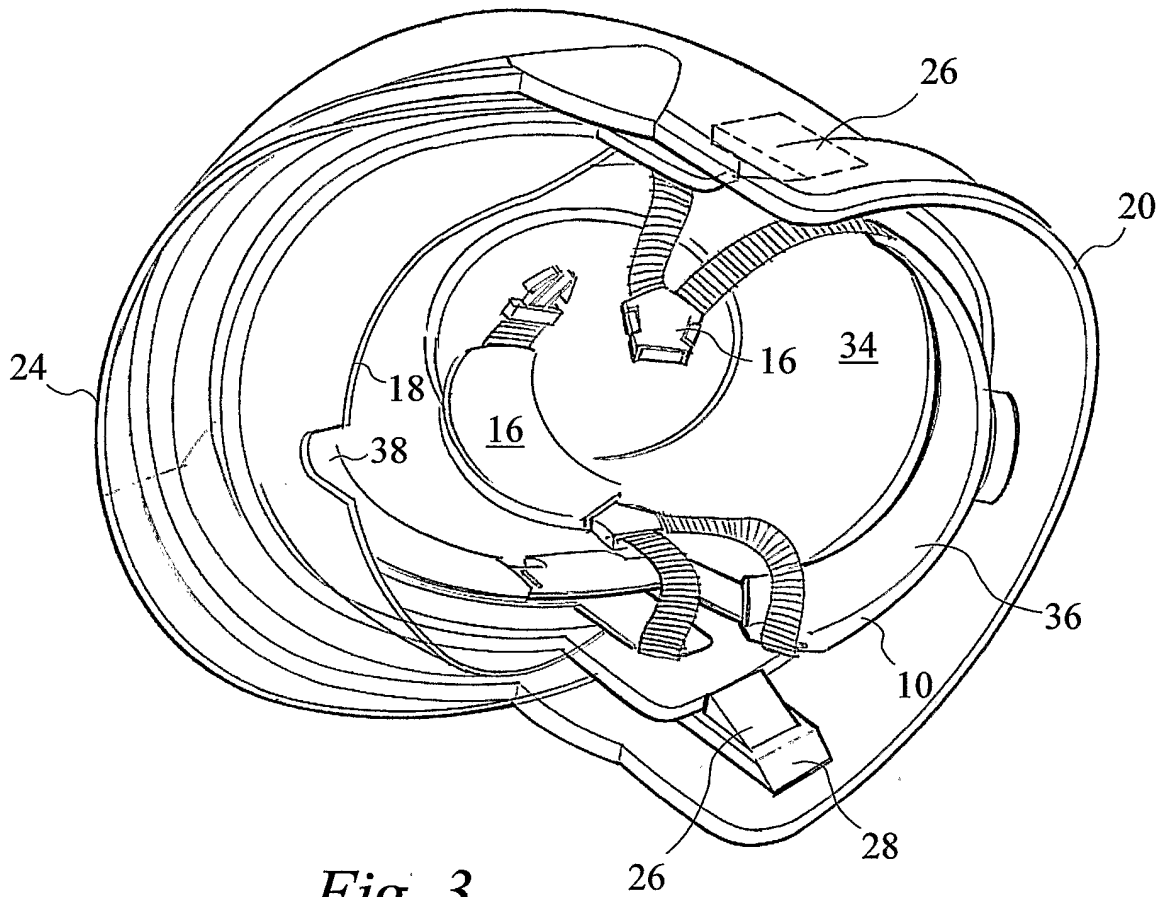

Fig. 3

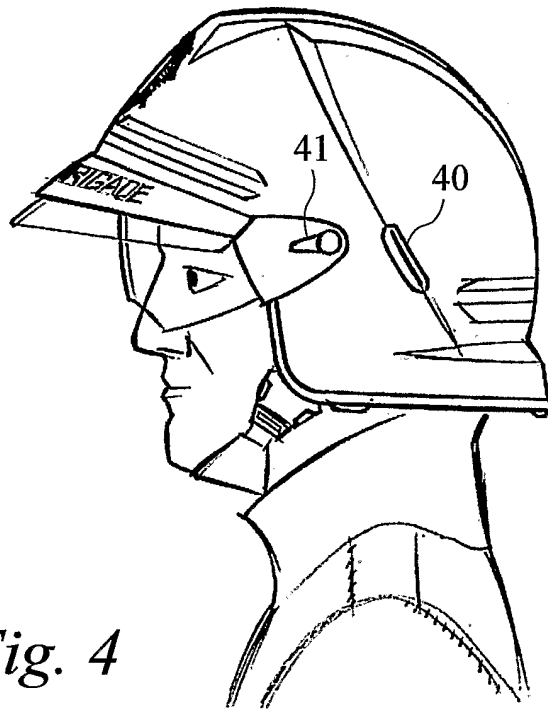

Fig. 4

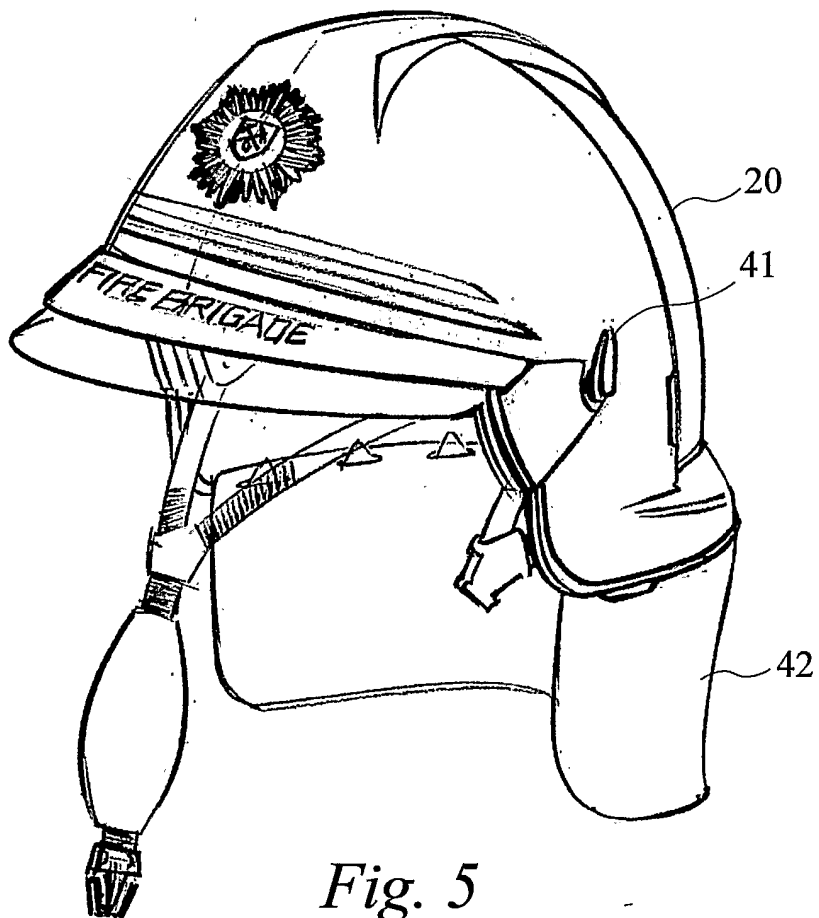

Fig. 5

5/11

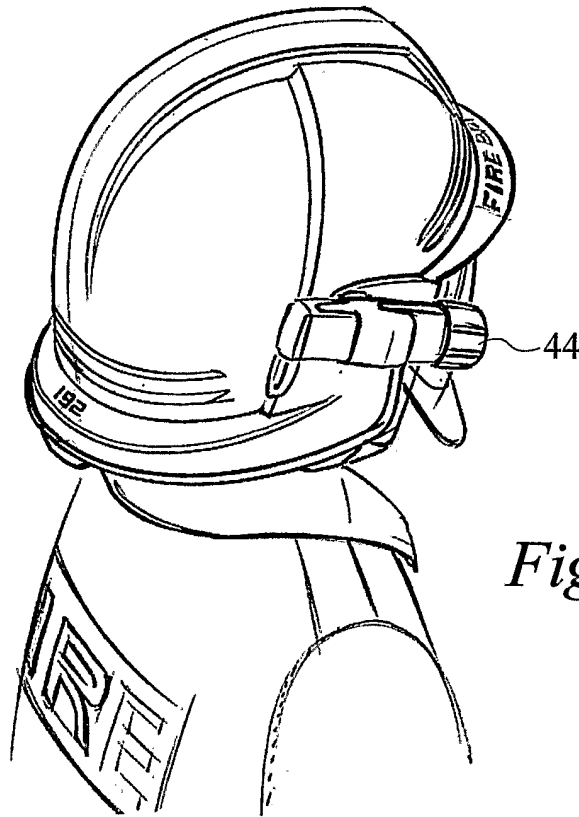

Fig. 6

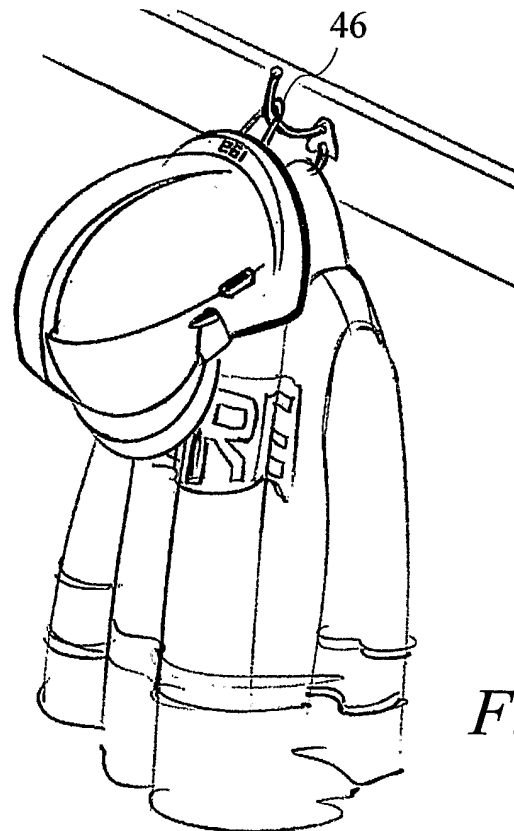

Fig. 7

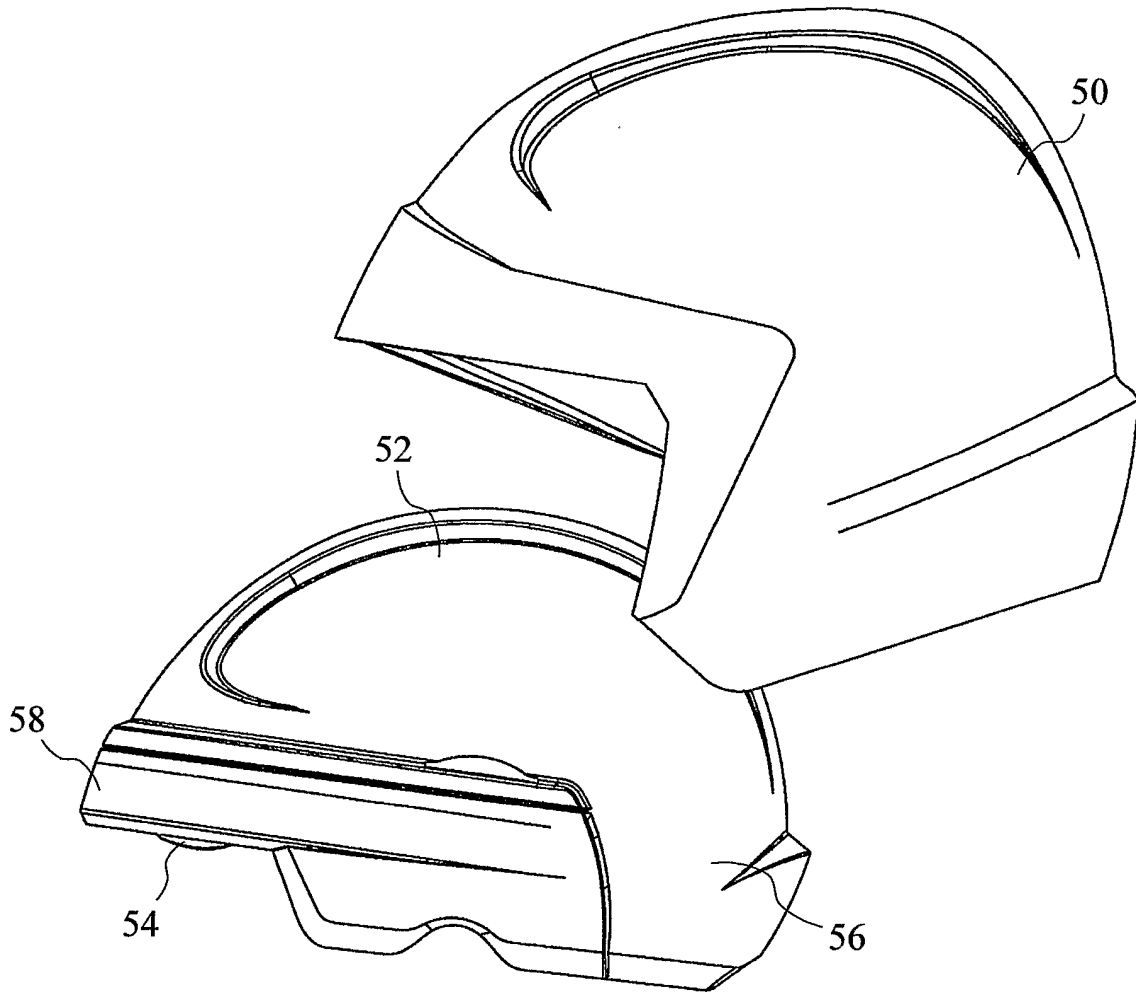

Fig. 8

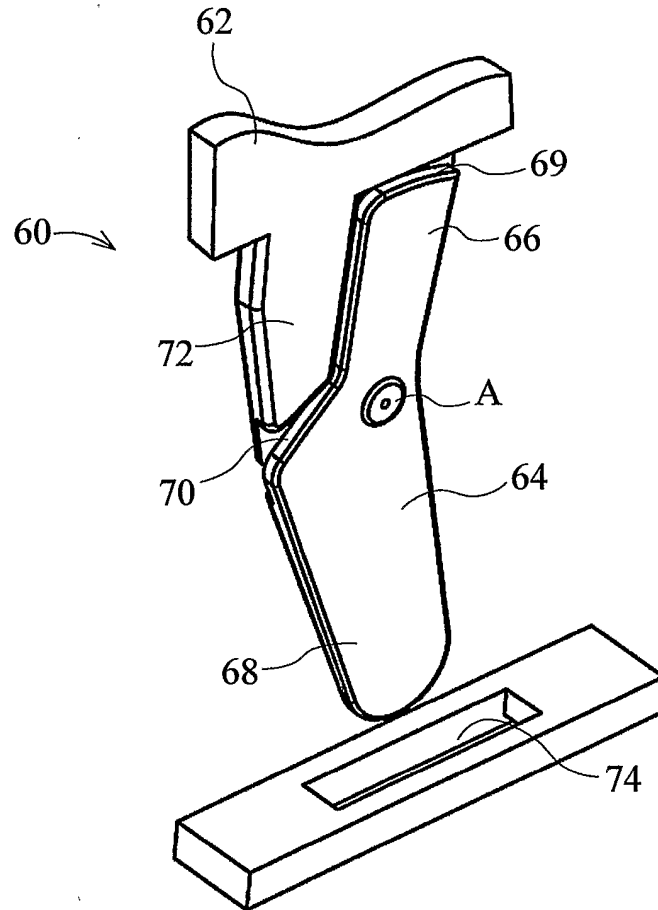

Fig. 9

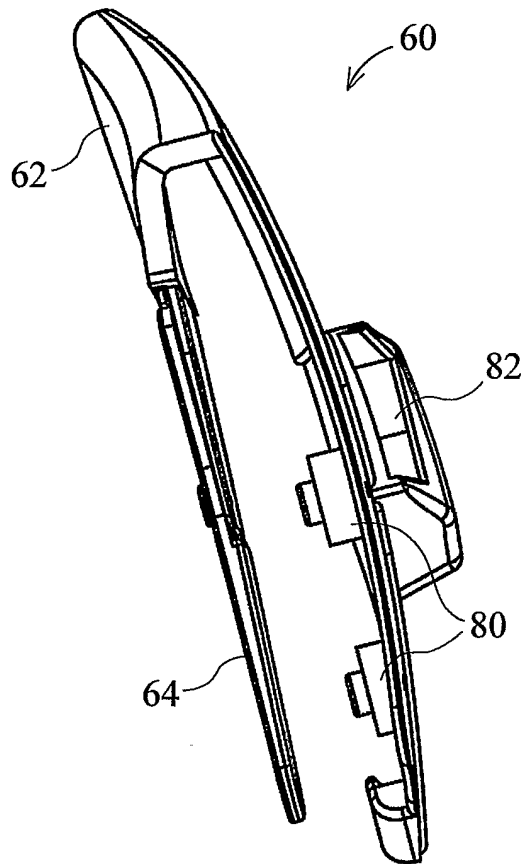

Fig. 10

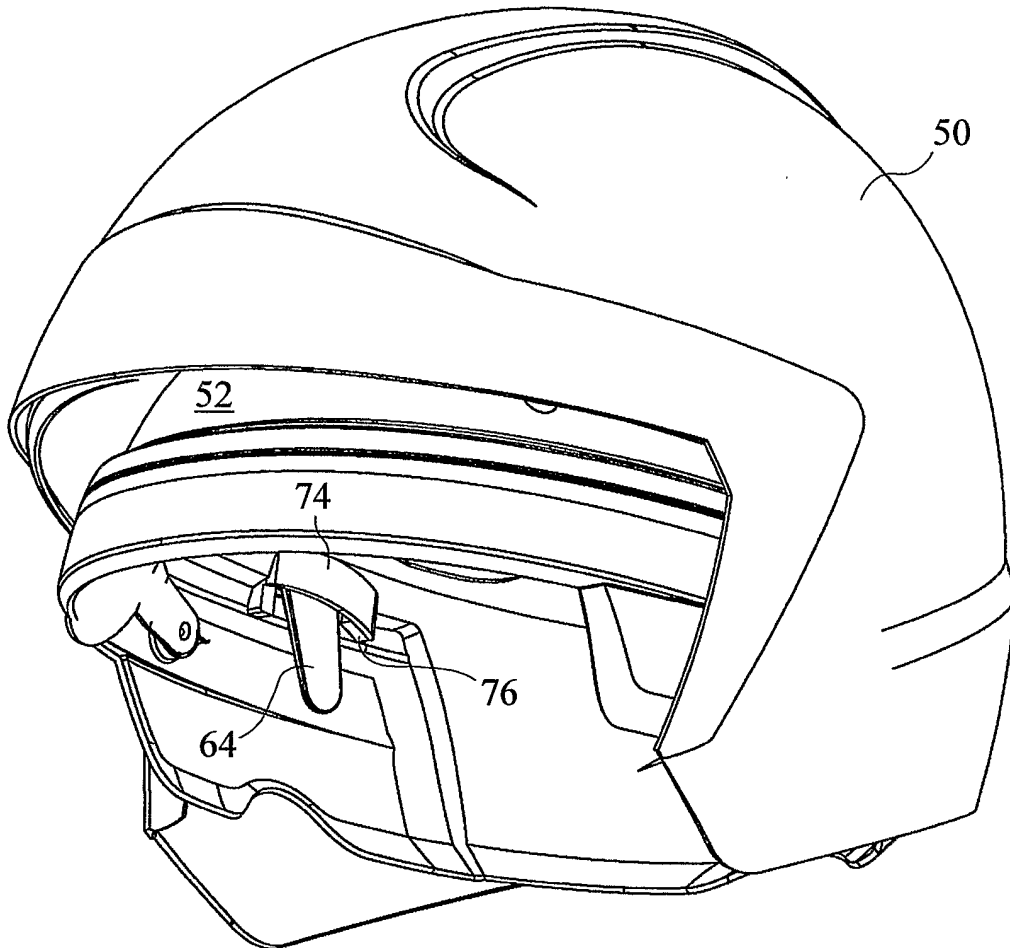

Fig. 11

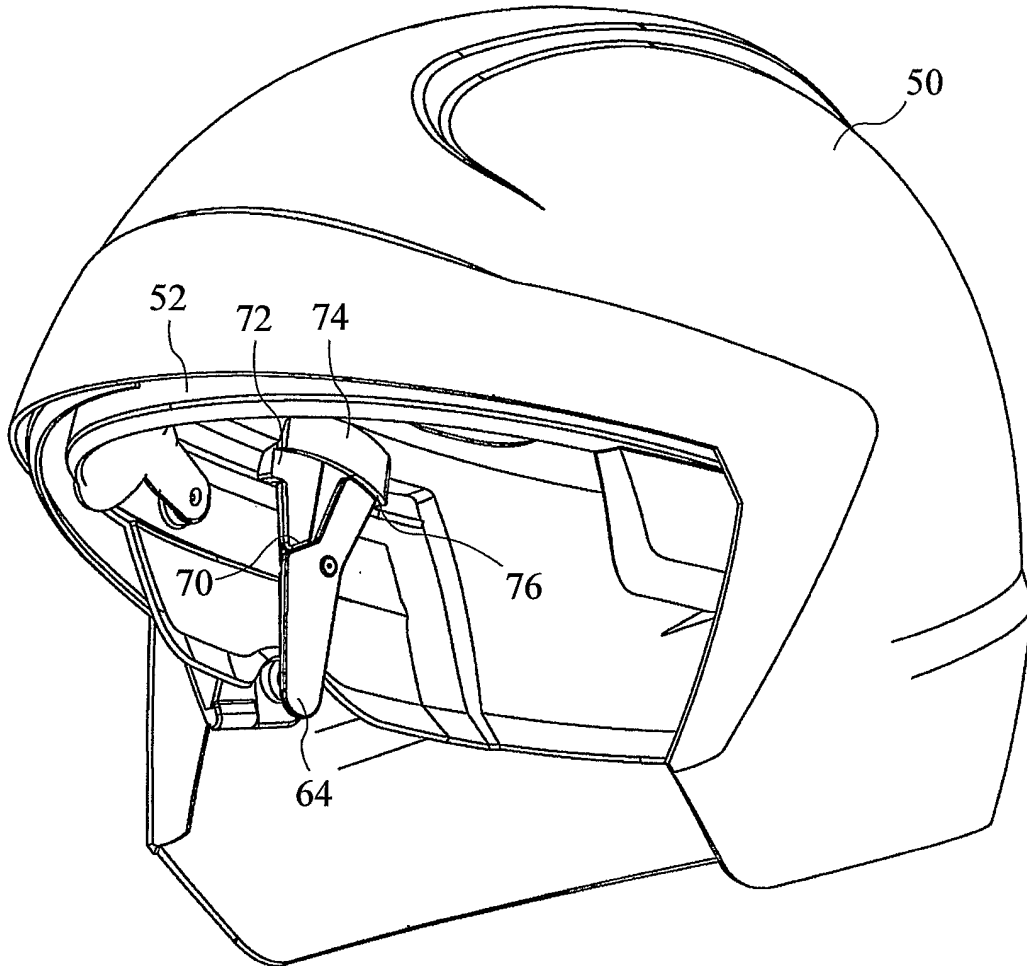

Fig. 12

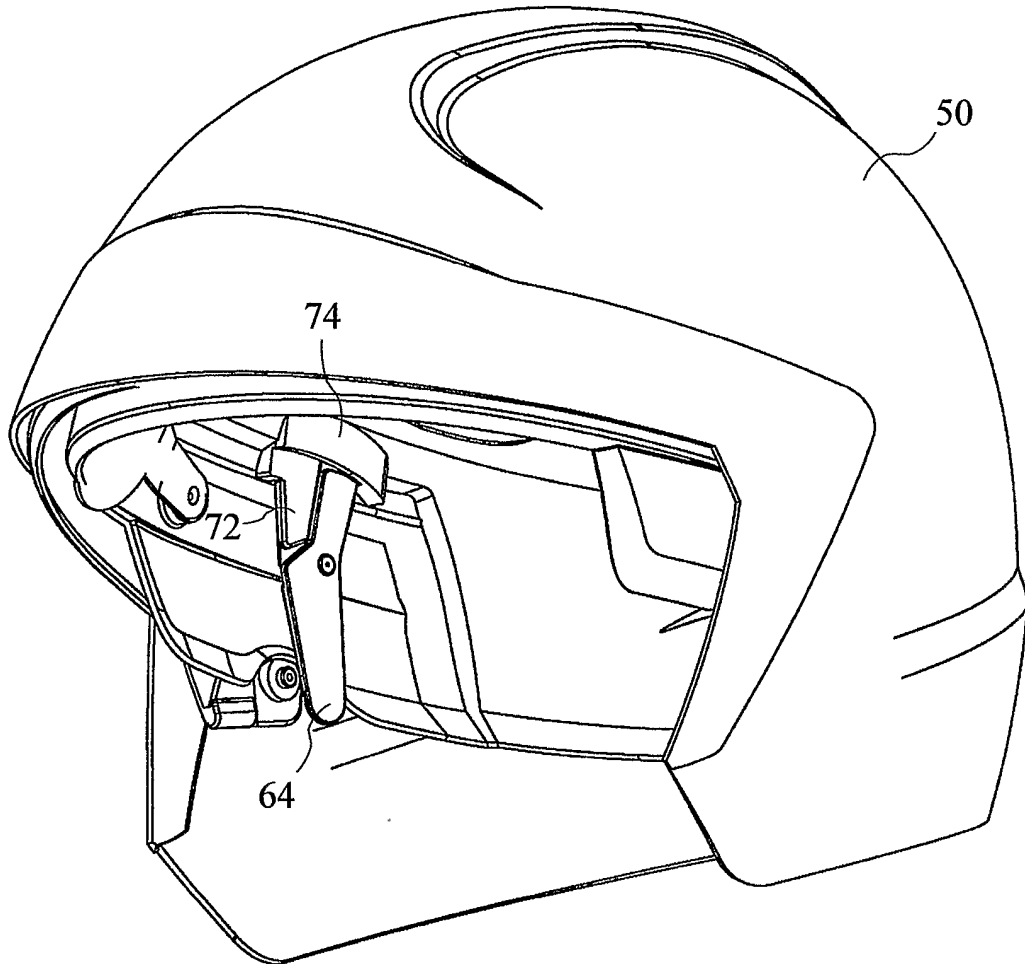

Fig. 13

INTERNATIONAL SEARCH REPORT

International Application No
PCT/GB2004/004290

A. CLASSIFICATION OF SUBJECT MATTER
IPC 7 A42B3/32

According to International Patent Classification (IPC) or to both national classification and IPC

B. FIELDS SEARCHED

Minimum documentation searched (classification system followed by classification symbols)
IPC 7 A42B

Documentation searched other than minimum documentation to the extent that such documents are included in the fields searched

Electronic data base consulted during the international search (name of data base and, where practical, search terms used)
EPO-Internal, WPI Data, PAJ

C. DOCUMENTS CONSIDERED TO BE RELEVANT

Category °	Citation of document, with indication, where appropriate, of the relevant passages	Relevant to claim No.
A	US 5 517 691 A (BLAKE BRUCE H) 21 May 1996 (1996-05-21) claim 1; figure 1	1,2
A	FR 2 750 299 A (SUIF FERNAND ALBERT) 2 January 1998 (1998-01-02) claim 1; figure 1	1,3
A	US 4 829 599 A (GIORGIO HUGO ET AL) 16 May 1989 (1989-05-16) claim 1; figure 1	1,2
A	PATENT ABSTRACTS OF JAPAN vol. 1999, no. 10, 31 August 1999 (1999-08-31) & JP 11 124719 A (SHIIRAIZU CORPORATION:KK), 11 May 1999 (1999-05-11) abstract	1

Further documents are listed in the continuation of box C.

Patent family members are listed in annex.

° Special categories of cited documents :

"A" document defining the general state of the art which is not considered to be of particular relevance
"E" earlier document but published on or after the international filing date
"L" document which may throw doubts on priority claim(s) or which is cited to establish the publication date of another citation or other special reason (as specified)
"O" document referring to an oral disclosure, use, exhibition or other means
"P" document published prior to the international filing date but later than the priority date claimed

"T" later document published after the international filing date or priority date and not in conflict with the application but cited to understand the principle or theory underlying the invention
"X" document of particular relevance; the claimed invention cannot be considered novel or cannot be considered to involve an inventive step when the document is taken alone
"Y" document of particular relevance; the claimed invention cannot be considered to involve an inventive step when the document is combined with one or more other such documents, such combination being obvious to a person skilled in the art.
"&" document member of the same patent family

Date of the actual completion of the international search

20 December 2004

Date of mailing of the international search report

04/02/2005

Name and mailing address of the ISA

European Patent Office, P.B. 5818 Patentlaan 2
NL - 2280 HV Rijswijk
Tel. (+31-70) 340-2040, Tx. 31 651 epo nl,
Fax: (+31-70) 340-3016

Authorized officer

D'Souza, J

INTERNATIONAL SEARCH REPORT

International Application No
PCT/GB2004/004290

Patent document cited in search report		Publication date	Patent family member(s)		Publication date
US 5517691	A	21-05-1996	NONE		
FR 2750299	A	02-01-1998	FR	2750299 A1	02-01-1998
US 4829599	A	16-05-1989	CA	1290500 C	15-10-1991
			US	4932076 A	12-06-1990
			CA	1321856 C2	07-09-1993
JP 11124719	A	11-05-1999	NONE		