



US 20060229650A1

(19) **United States**

(12) **Patent Application Publication**

**Vetter et al.**

(10) **Pub. No.: US 2006/0229650 A1**

(43) **Pub. Date: Oct. 12, 2006**

(54) **METHODS AND DEVICES FOR CUTTING AND COLLECTING SOFT TISSUE**

**Related U.S. Application Data**

(75) Inventors: **James W. Vetter**, Portola Valley, CA (US); **Ary S. Chernomorsky**, Walnut Creek, CA (US); **Mark J. Clifford**, Los Altos, CA (US); **Dan Brounstein**, Fremont, CA (US); **Scott C. Anderson**, Sunnyvale, CA (US)

(60) Division of application No. 10/272,452, filed on Oct. 16, 2002, now Pat. No. 7,044,956, which is a continuation-in-part of application No. 10/189,277, filed on Jul. 3, 2002.

**Publication Classification**

(51) **Int. Cl.**  
*A61B 17/32* (2006.01)  
(52) **U.S. Cl.** ..... **606/180**

Correspondence Address:  
**YOUNG LAW FIRM, P.C.**  
**ALAN W. YOUNG**  
**4370 ALPINE ROAD**  
**SUITE 106**  
**PORTOLA VALLEY, CA 94028 (US)**

(57) **ABSTRACT**

Devices and methods for cutting and collecting a specimen from a mass of tissue. The device may include an integrated cut and collect assembly. The integrated cut and collect assembly includes a cutting portion and a collection portion that includes a flexible membrane. The collection portion of the assembly is attached to the cutting portion thereof. The cutting portion is configured to cut the specimen from the mass of tissue and the collection portion is configured to collect the cut specimen and to encapsulate and isolate the cut specimen within the membrane to enable its safe retraction from the mass of tissue.

(73) Assignee: **Rubicon Medical, Inc.**, Redwood City, CA

(21) Appl. No.: **11/391,791**

(22) Filed: **Mar. 28, 2006**

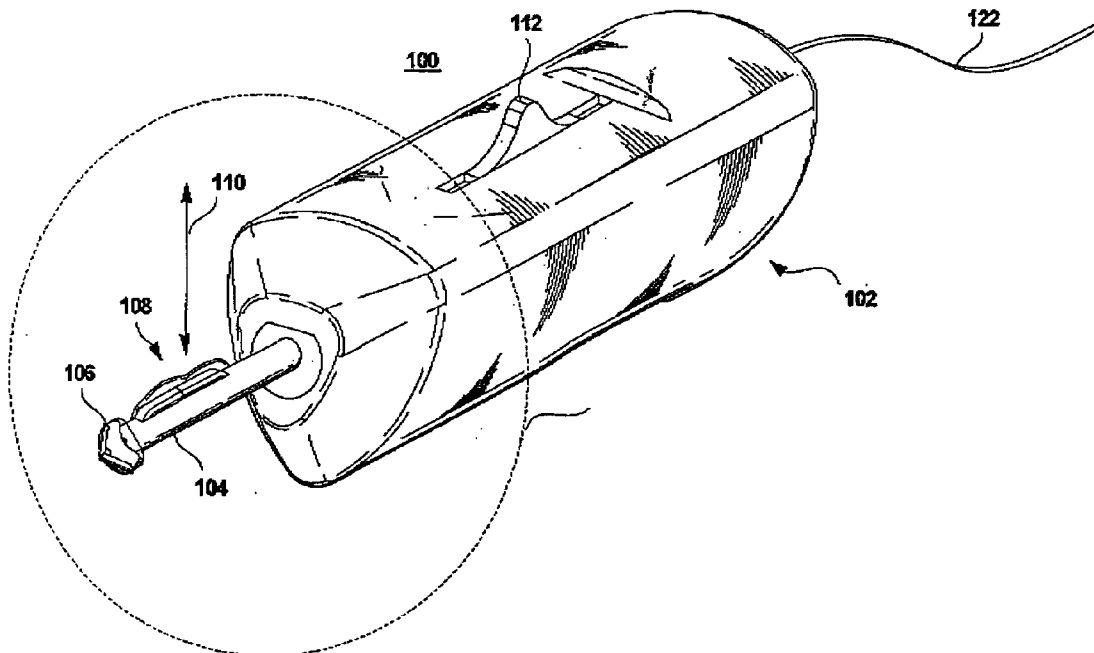

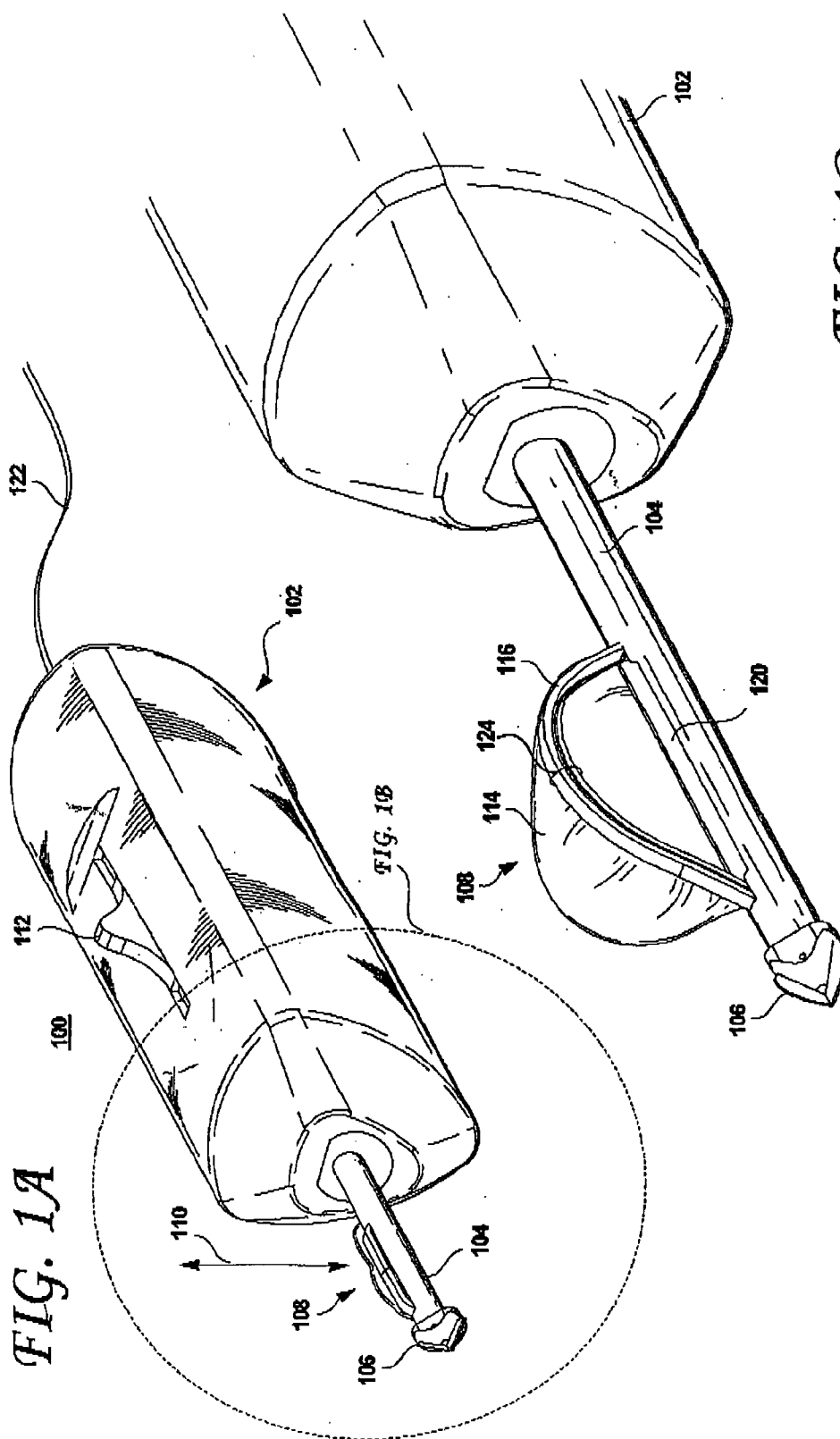

FIG. 1A

FIG. 1B

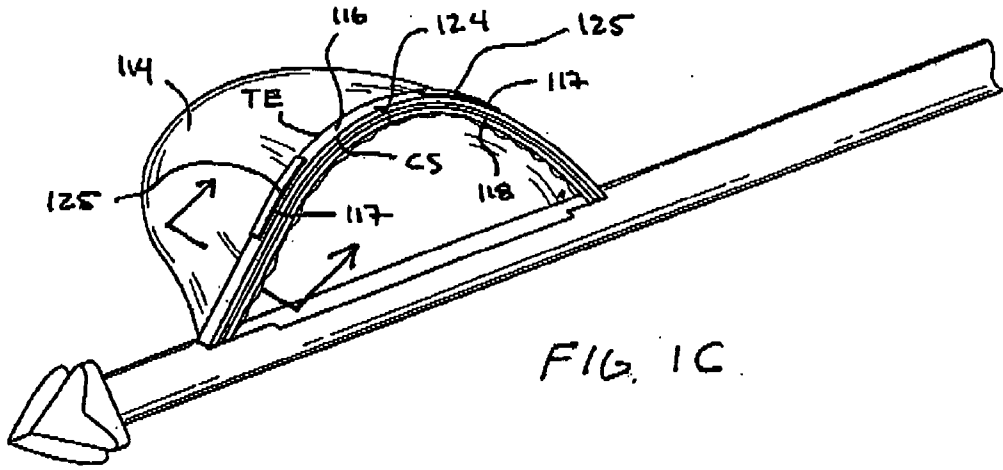

FIG. 1C

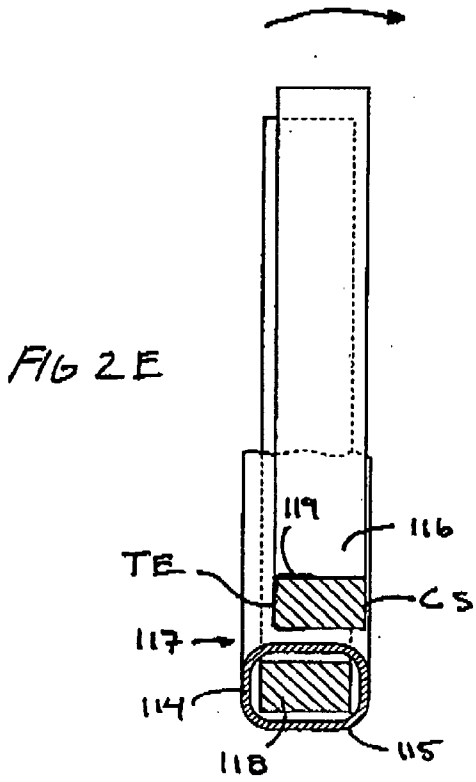

FIG. 2E

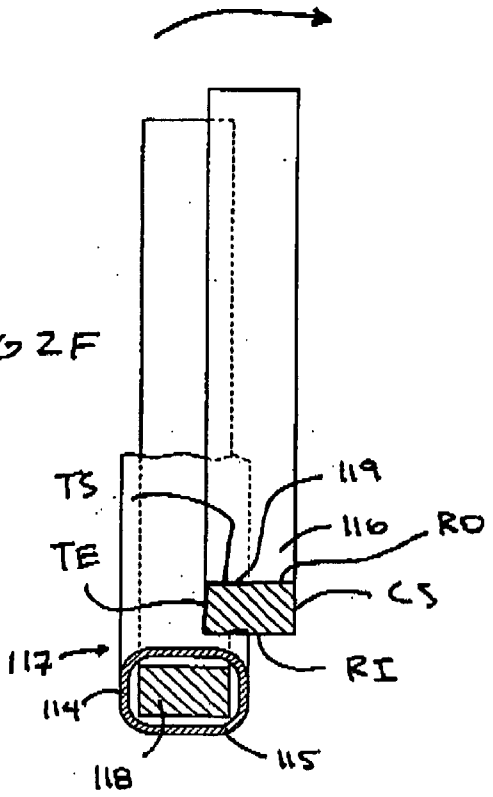

FIG. 2F

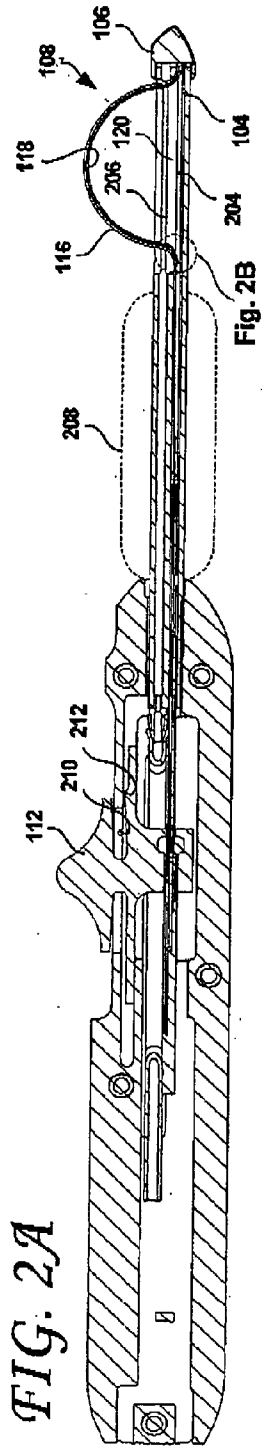

Fig. 2B

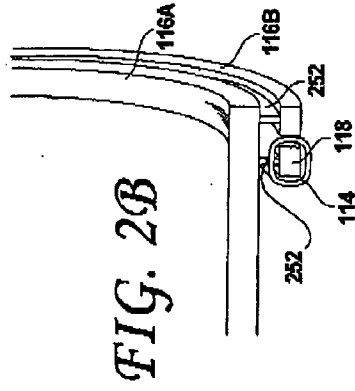

FIG. 2B

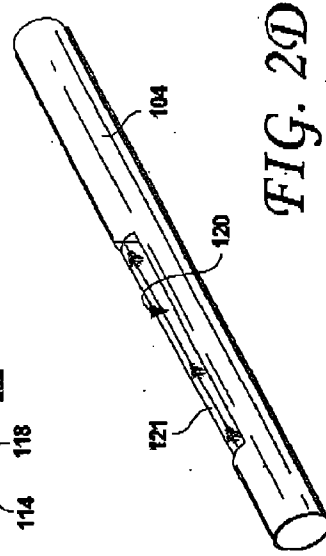

FIG. 2D

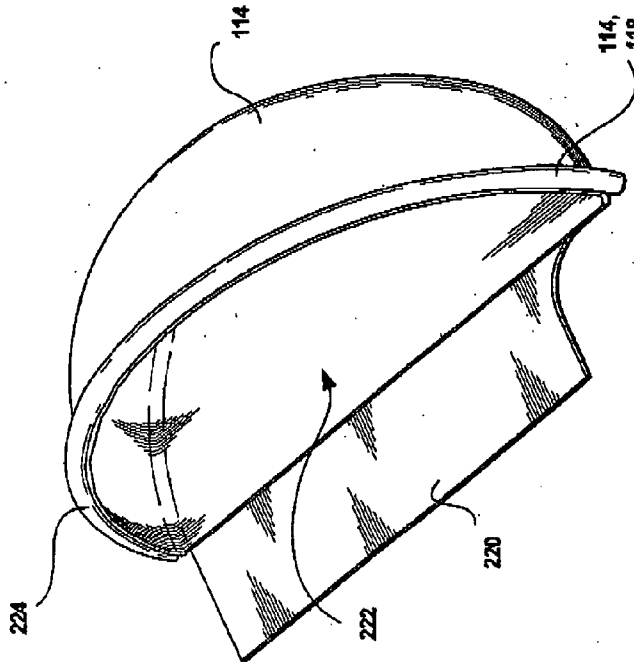

FIG. 2C

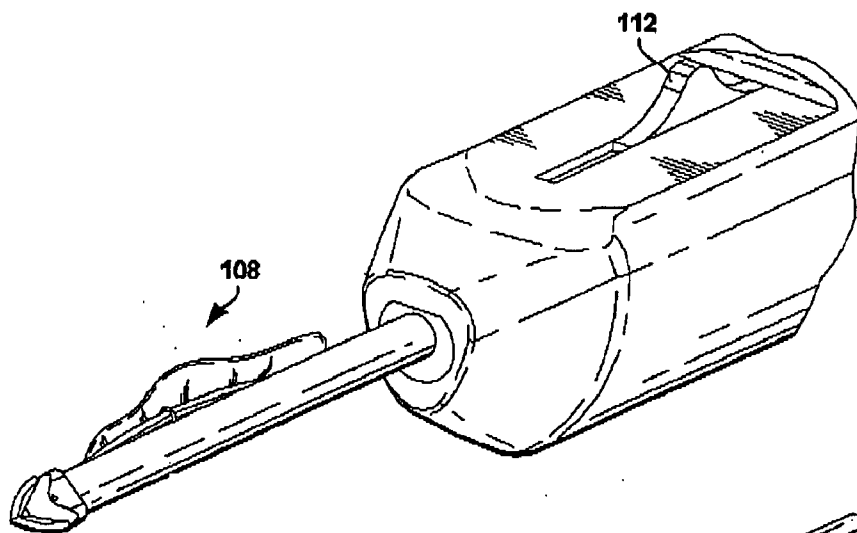

FIG. 3

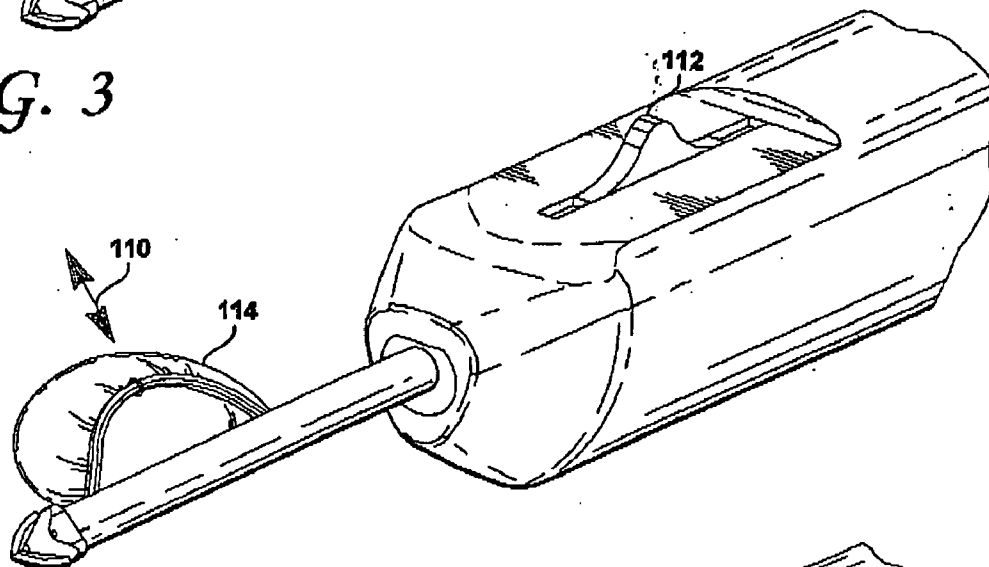

FIG. 4

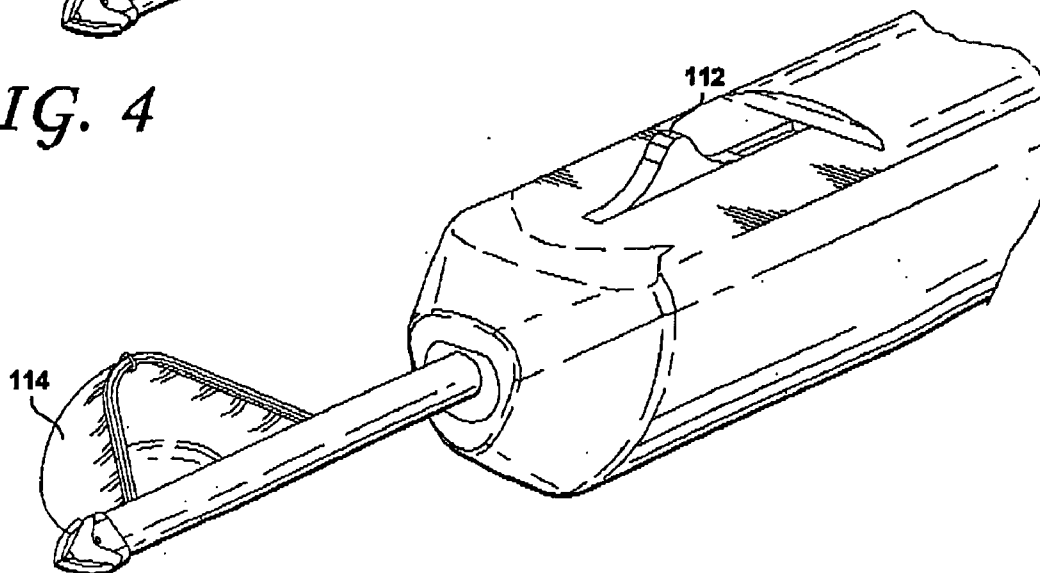

FIG. 5

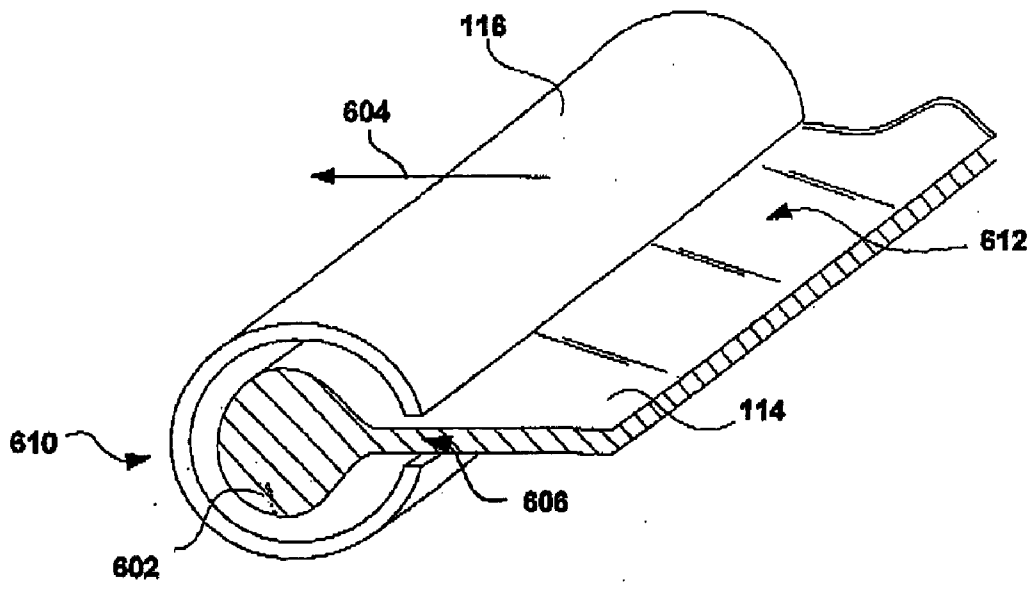

FIG. 6

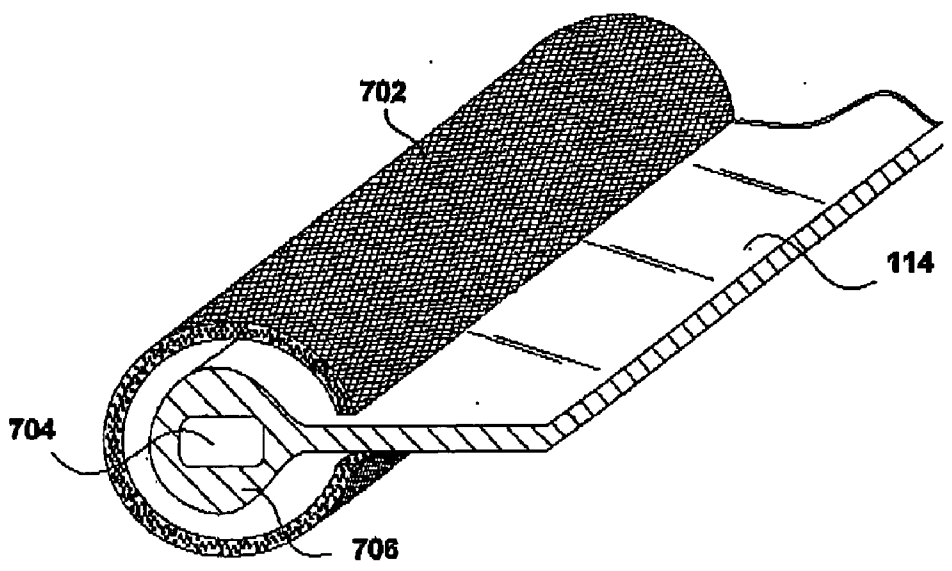
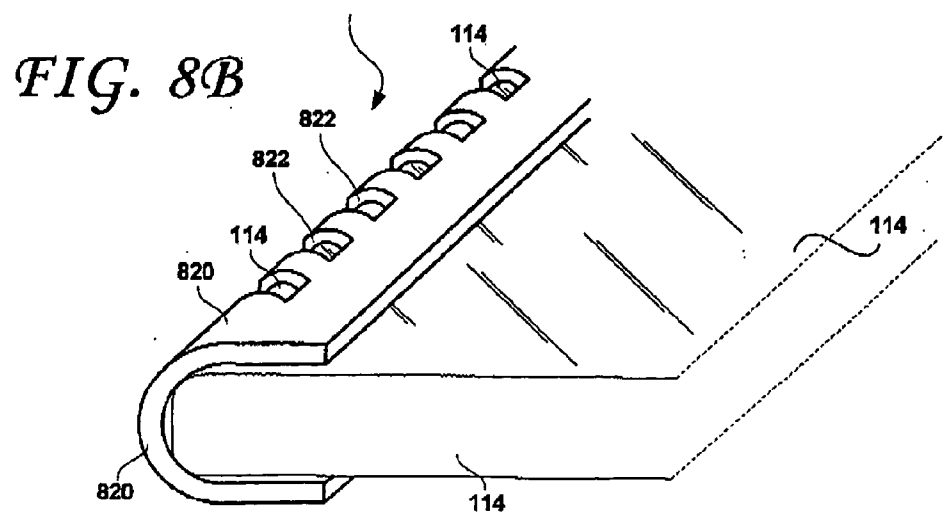
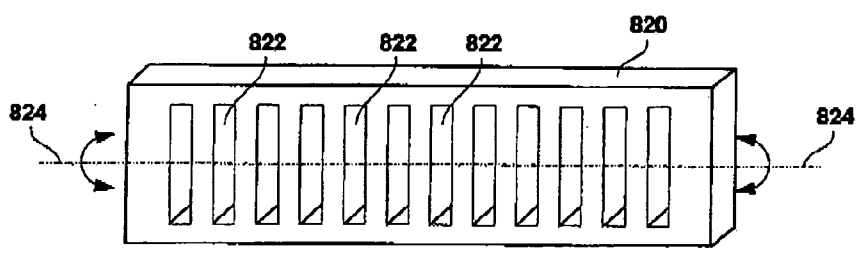
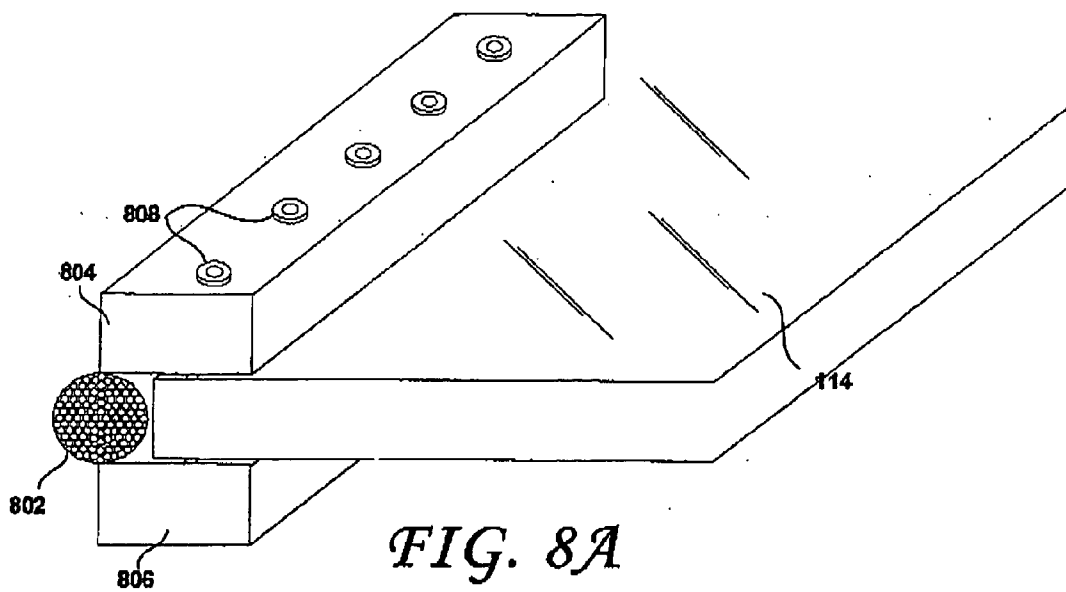

FIG. 7



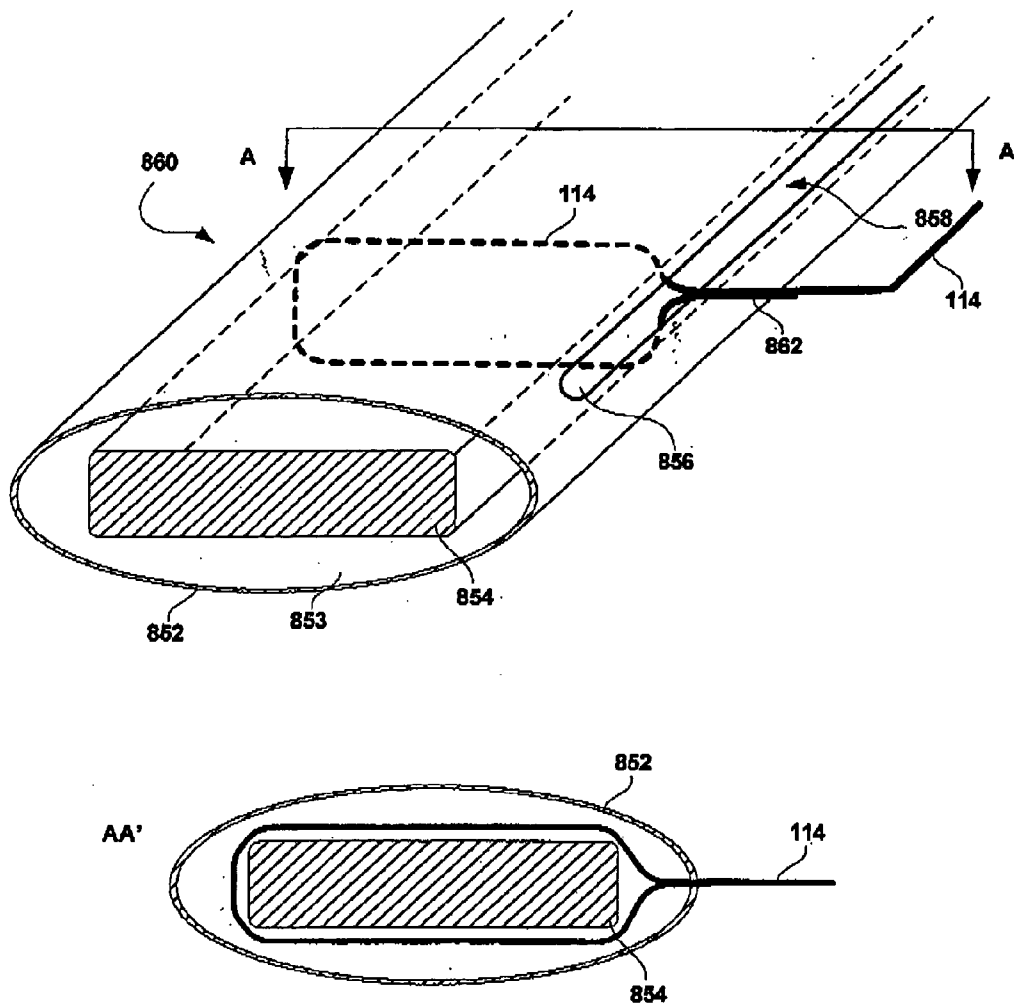
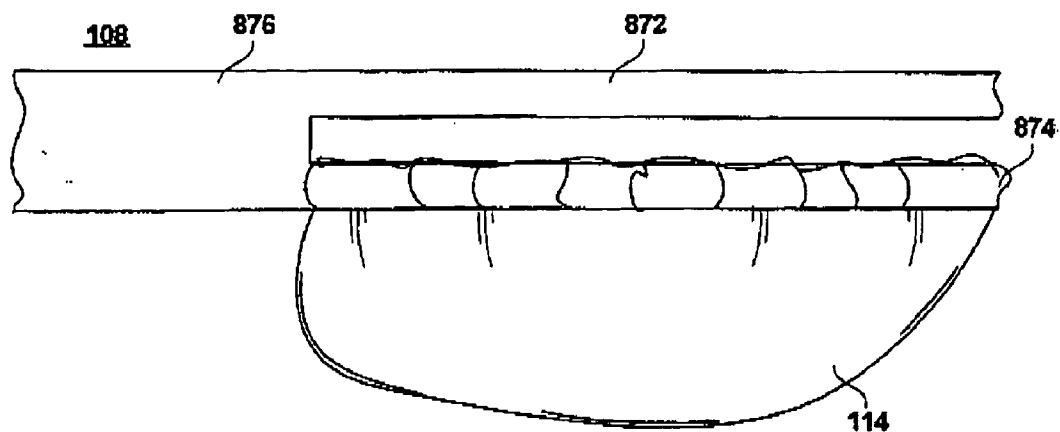
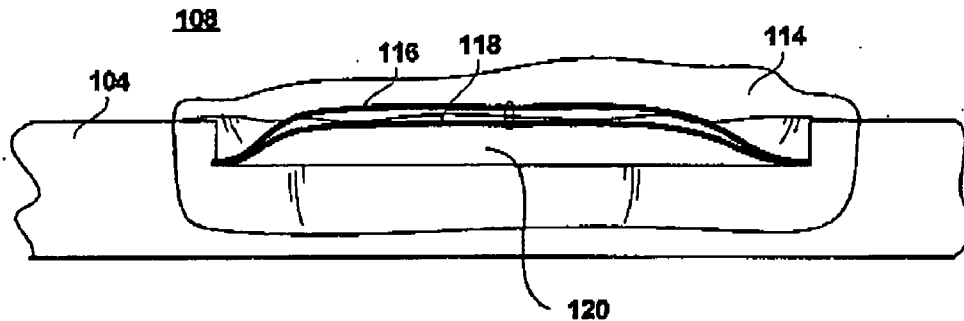

FIG. 8C

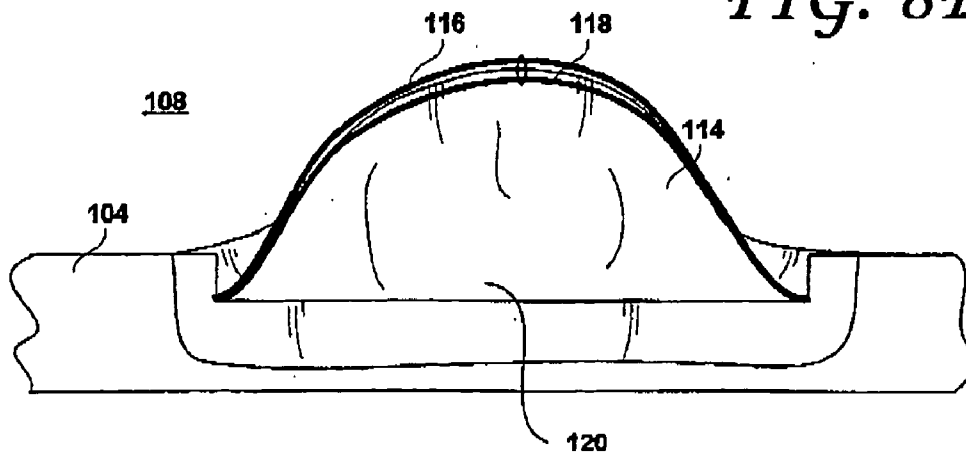

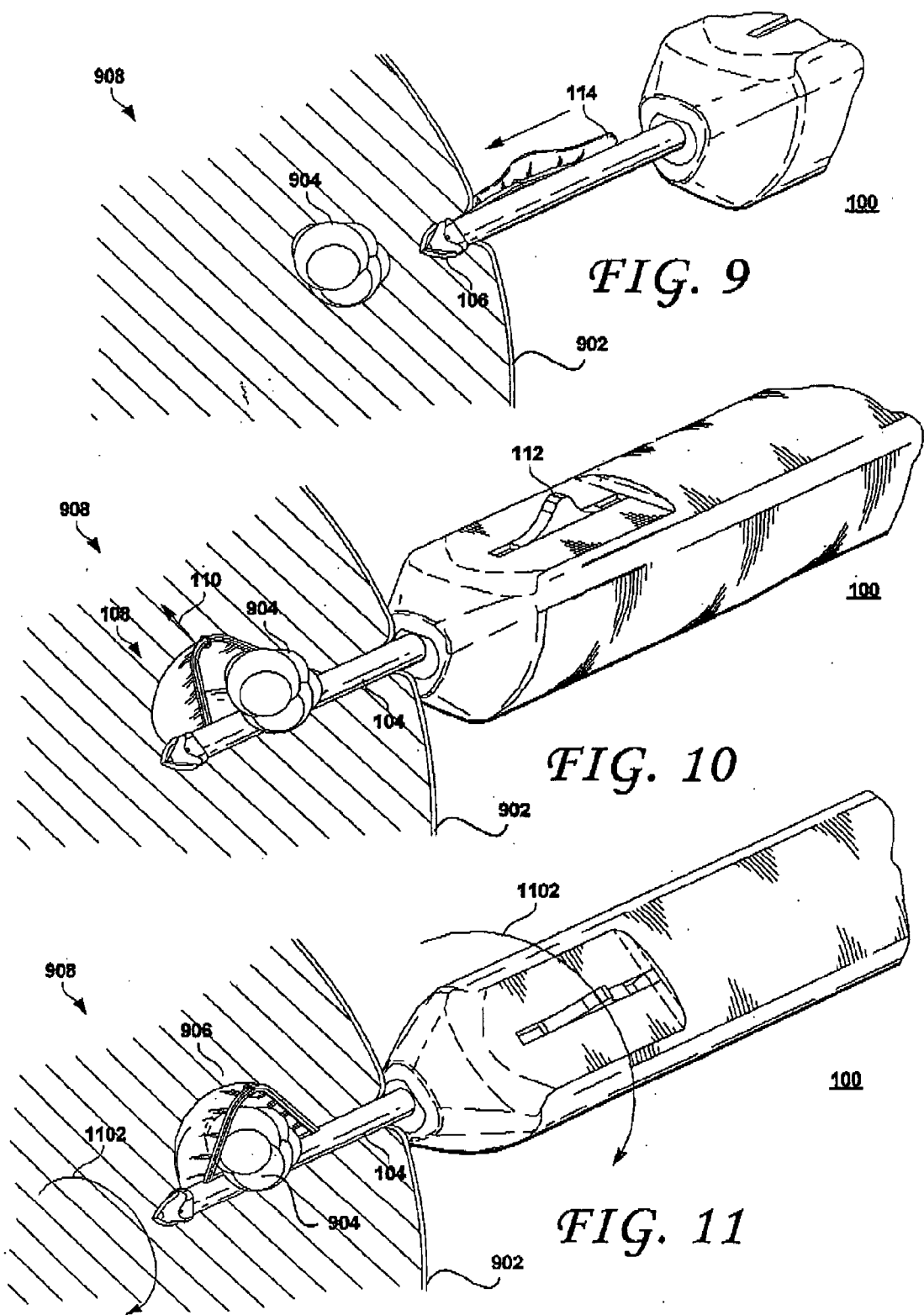

*FIG. 8D*



*FIG. 8E*





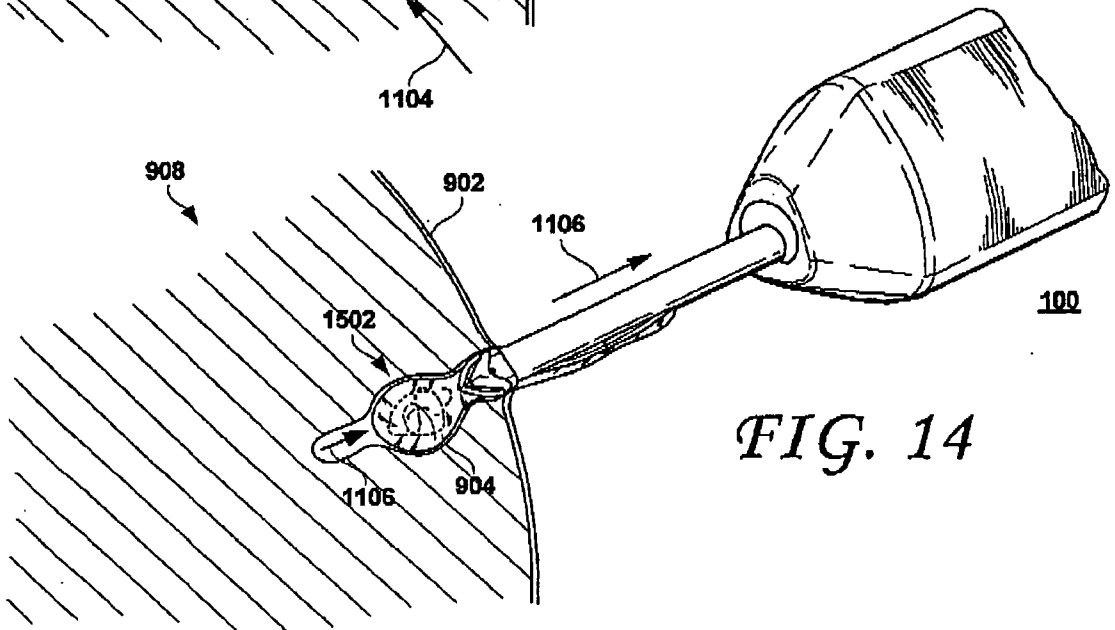
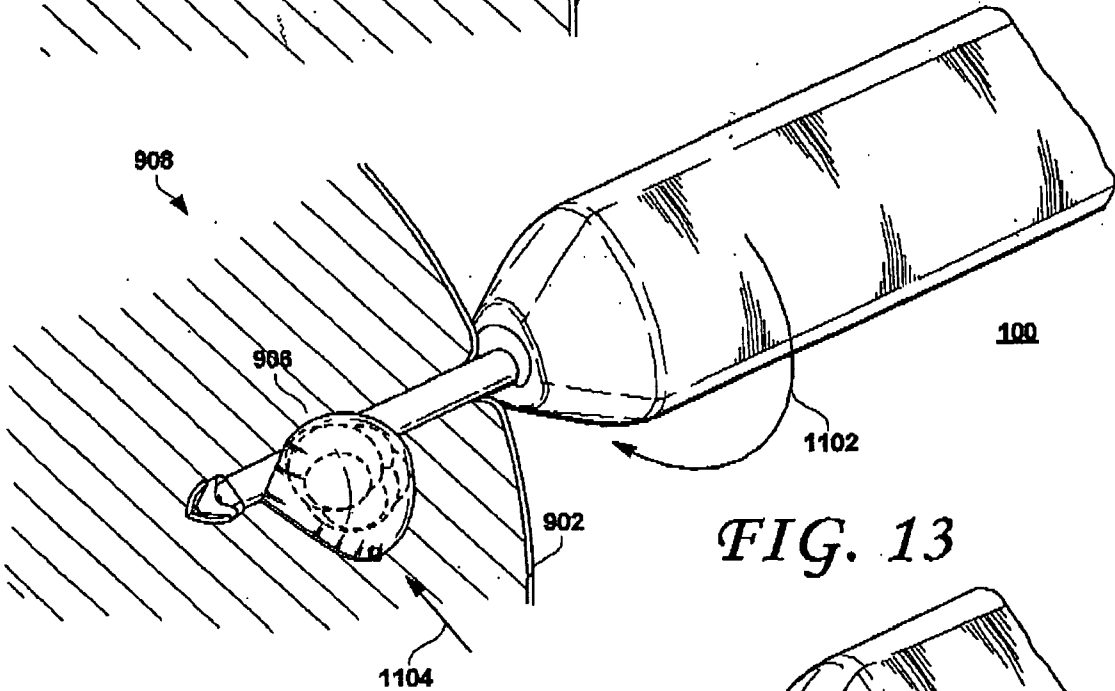
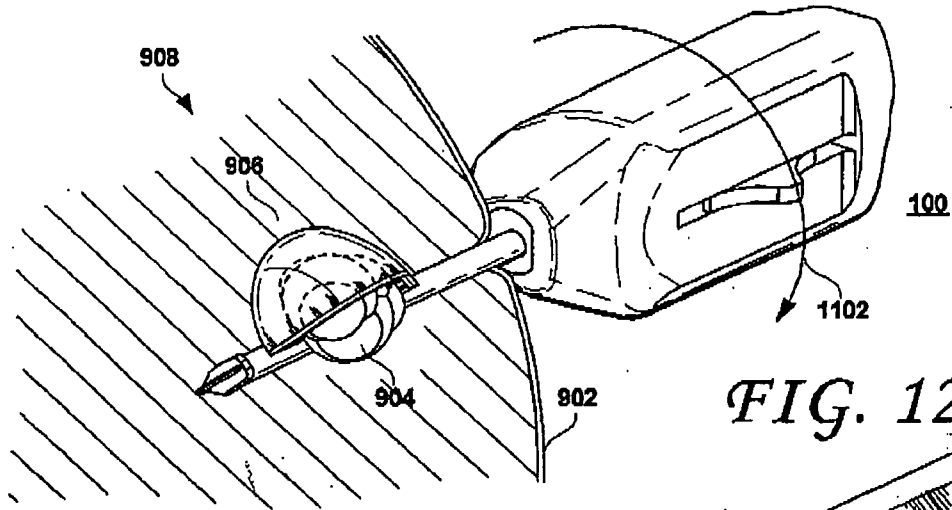

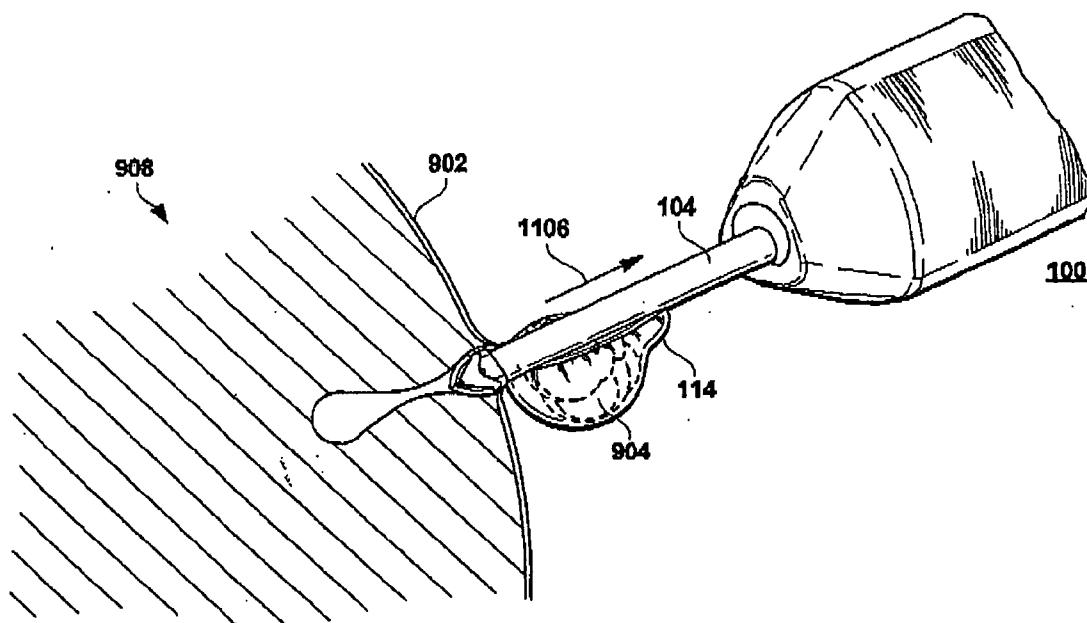

FIG. 15

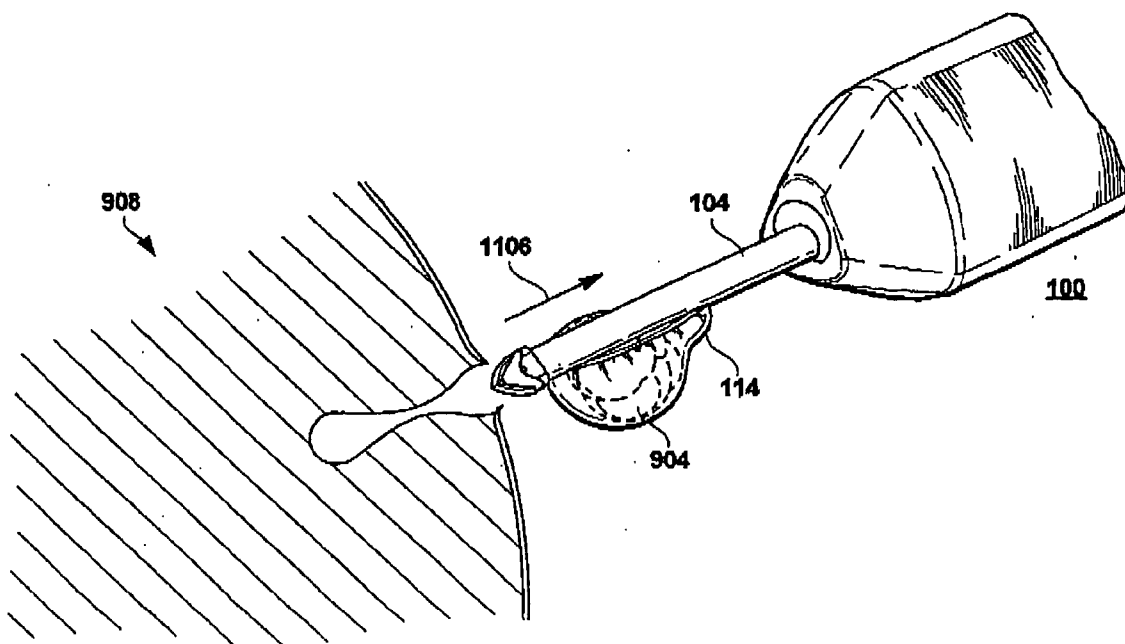

FIG. 16

**METHODS AND DEVICES FOR CUTTING AND COLLECTING SOFT TISSUE**

[0001] This application is a divisional application of prior copending application Ser. No. 10/272,172, filed Oct. 16, 2002, which is a continuation-in-part of application Ser. No. 10/189,277, filed on Jul. 3, 2002, from which applications priority is hereby claimed under 35 U.S.C. §120, and both applications of which are hereby incorporated herein by reference in their entirety.

**BACKGROUND OF THE INVENTION**

[0002] 1. Field of the Invention

[0003] The present invention pertains to the field of soft tissue excisional devices and methods. In particular, the present invention relates to the field of devices and methods for excising specimen from soft tissue, such as breast tissue, for example.

[0004] 2. Description of the Related Art

[0005] Breast cancer is a major threat and concern to women. Early detection and treatment of suspicious or cancerous lesions in the breast has been shown to improve long-term survival of the patient. The trend is, therefore, to encourage women not only to perform monthly self-breast examination and obtain a yearly breast examination by a qualified physician, but also to undergo annual screening mammography commencing at age 40. Mammography is the only screening modality available today that can detect small, nonpalpable lesions. These nonpalpable lesions may appear as opaque densities relative to normal breast parenchyma and fat or as clusters of microcalcifications.

[0006] The conventional method for diagnosing, localizing and excising nonpalpable lesions detected by mammography generally involves a time-consuming, multi-step process. First, the patient goes to the radiology department where the radiologist finds and localizes the lesion either using mammography or ultrasound guidance. Once localized, a radio-opaque wire is inserted into the breast. The distal end of the wire may include a small hook or loop. Ideally, this is placed adjacent to the suspicious area to be biopsied. The patient is then transported to the operating room. Under general or local anesthesia, the surgeon performs a procedure called a needle-localized breast biopsy. In the needle-localized breast biopsy, the surgeon, guided by the wire previously placed in the patient's breast, excises a mass of tissue around the distal end of the wire. The specimen is sent to the radiology department where a specimen radiograph is taken to confirm that the suspicious lesion is contained within the excised specimen. Meanwhile, the surgeon, patient, anesthesiologist and operating room staff, wait in the operating room for confirmation of that fact from the radiologist before the operation is completed. The suspicious lesion should ideally be excised in toto with a small margin or rim of normal breast tissue on all sides. Obtaining good margins of normal tissue is extremely dependent upon the skill and experience of the surgeon, and often an excessively large amount of normal breast tissue is removed to ensure that the lesion is located within the specimen. This increases the risk of post-operative complications, including bleeding and permanent breast deformity. As 80% of breast biopsies today are benign, many women unnecessarily suffer from permanent scarring and deformity from such benign breast biopsies.

[0007] More recently, less invasive techniques have been developed to sample or biopsy the suspicious lesions to obtain a histological diagnosis. The simplest of the newer techniques is to attempt visualization of the lesion by external ultrasound. If seen by external ultrasound, the lesion can be biopsied while being continuously visualized. This technique allows the physician to see the biopsy needle as it actually enters the lesion, thus ensuring that the correct area is sampled. Current sampling systems for use with external ultrasound guidance include a fine needle aspirate, core needle biopsy or vacuum-assisted biopsy devices.

[0008] Another conventional technique localizes the suspicious lesion using stereotactic digital mammography. The patient is placed prone on a special table that includes a hole to allow the designated breast to dangle therethrough. The breast is compressed between two mammography plates, which stabilizes the breast to be biopsied and allows the digital mammograms to be taken. At least two images are taken at two angular positions to obtain stereotactic views. The x, y and z coordinates targeting the lesion are calculated by a computer. The physician then aligns a special mechanical stage mounted under the table that places the biopsy device into the breast to obtain the sample or samples. There are believed to be three methods available to biopsy lesions using a stereotactic table: (1) fine needle aspiration, (2) core needle biopsy and (3) vacuum-assisted core needle biopsy.

[0009] Fine needle aspiration uses a small gauge needle, usually 20 to 25 gauge, to aspirate a small sample of cells from the lesion or suspicious area. The sample is smeared onto slides that are stained and examined by a cytopathologist. In this technique, individual cells in the smears are examined, and tissue architecture or histology is generally not preserved. Fine needle aspiration is also very dependent upon the skill and experience of the operator and can result in a high non-diagnostic rate (up to about 83%), due to inadequate sample collection or preparation.

[0010] Core needle biopsy uses a larger size needle, usually 14 gauge to sample the lesion. Tissue architecture and histology are preserved with this method. A side-cutting device, consisting of an inner trough with an outer cutting cannula is attached to a spring-loaded device for a rapid semi-automated firing action. After the lesion is localized, local anesthetic is instilled and a small incision is made in the skin with a scalpel. The device enters the breast and the needle tip is guided into the breast up to the targeted lesion. The device is fired. First, the inner cannula containing the trough rapidly penetrates the lesion. Immediately following this, the outer cutting cannula rapidly advances over the inner cannula cutting a sample of tissue off in the trough. The whole device is then removed and the sample retrieved. Multiple penetrations of the core needle through the breast and into the lesion are required to obtain an adequate sampling of the lesion. Over 10 samples have been recommended by some.

[0011] The vacuum-assisted breast biopsy system is a larger semi-automated side-cutting device. It is usually 11 gauge in diameter and is more sophisticated than the core needle biopsy device. Multiple large samples can be obtained from the lesion without having to reinsert the needle each time. A vacuum is added to suck the tissue into the trough. The rapid firing action of the spring-loaded core needle device is replaced with an oscillating outer cannula

that cuts the breast tissue off in the trough. The physician controls the speed at which the outer cannula advances over the trough and can rotate the alignment of the trough in a clockwise fashion to obtain multiple samples.

[0012] If a fine needle aspirate, needle core biopsy or vacuum-assisted biopsy shows malignancy or a specific benign diagnosis of atypical hyperplasia, then the patient needs to undergo another procedure, the traditional needle-localized breast biopsy, to fully excise the area with an adequate margin of normal breast tissue. Sometimes the vacuum-assisted device removes the whole targeted lesion. If this occurs, a small titanium clip should be placed in the biopsy field. This clip marks the area if a needle-localized breast biopsy is subsequently required for the previously mentioned reasons.

[0013] Another method of biopsying the suspicious lesion utilizes a large end-cutting core device measuring 0.5 cm to 2.0 cm in diameter. This also uses the stereotactic table for stabilization and localization. After the lesion coordinates are calculated and local anesthesia instilled, an incision large enough is permit entry of the bore is made at the entry site with a scalpel. The breast tissue is cored down to and past the lesion. Once the specimen is retrieved, the patient is turned onto her back and the surgeon cauterizes bleeding vessels under direct vision. The incision, measuring 0.5 to larger than 2.0 cm is sutured closed.

[0014] The stereotactic table requires awkward positioning of the patient and may be extremely uncomfortable. The woman must lie prone during the entire procedure, which may be impossible for some patients. In addition, the lesion to be biopsied must be in the center working area of the mammography plates. This may be extremely difficult and uncomfortable for the patient if the lesion is very posterior near the chest wall or high towards the axilla.

[0015] The woman is subjected to increased radiation exposure as multiple radiographs are required throughout the course of the procedure to: (1) confirm that the lesion is within the working area of the mammography plates, (2) obtain the stereotactic coordinates (at least two views), (3) verify the positioning of the biopsy needle prior to obtaining tissue, and (4) verify that the lesion was indeed sampled. If any difficulty is encountered during the procedure, additional radiographic exposures are required to verify correction of the problem.

[0016] Using the core needle biopsy or vacuum-assisted device, bleeding is controlled only by manual pressure. Bleeding is generally not an issue with fine needle aspiration, but is a legitimate complication of the former two methods. Ecchymoses, breast edema and hematomas can occur. This causes increased post-procedural pain and delays healing. Rarely, the patient may require an emergency operation to control and evacuate a tense hematoma.

[0017] Another major concern is the possibility of tumor dissemination. The core needle biopsy and vacuum-assisted devices both cut into the tumor and carve out multiple samples for examination. While cutting into the tumor, cancerous cells may be dislodged. Cutting across blood vessels at the same time may allow the freed cancerous cells access to the blood stream, thus possibly seeding the tumor beyond its original locus. The long-term consequences of tumor seeding with the risk of blood borne metastases are

unknown at this time, as the techniques are relatively new. However, documented instances of cancerous cells seeding locally into needle tracks exist. There are numerous reports of metastases growing in needle tracks from previous biopsies of a cancerous mass. Most of these are from lung or liver cancers. However, at least one case of mucinous carcinoma of the breast growing in a needle track has been reported. The long-term consequences of neoplasm seeding into needle tracks are currently unknown, again because the techniques are relatively new. Some recommend excision of the entire needle track, including the skin entry site, during the definitive surgical procedure for a diagnosed cancer, whether it is a lumpectomy or a mastectomy. Others assume that with a lumpectomy, the post-operative radiation therapy will destroy any displaced cancer cells in the needle track. With the trend towards treating very small cancers only by excision and without a post-excision course of radiation therapy, the risk of cancer cells metastasizing and growing in needle tracks is very real.

[0018] The large core cutting device (0.5 cm to 2.0 cm) generally eliminates the risk of needle track seeding as it is designed to excise the lesion intact. A stereotactic table is required with the same inherent awkwardness for the patient, as discussed above. Bleeding is controlled, albeit manually, requiring that the patient wait until the end of the procedure to be turned over. Compression is used to stabilize the breast and localize the lesions. The breast, however, may be torqued and distorted between the compression plates such that when the plates are removed after the biopsy, the large core track left behind may not be straight, but actually tortuous. This can result in permanent breast deformity.

[0019] The location of the insertion site into the breast is dictated by the positioning of the breast in the machine and not by the physician. The entry site is usually away from the cosmetically preferred nipple-areolar complex and is usually located on the more exposed areas of the breast. For the fine needle aspirate, core biopsy and vacuum-assisted devices, the incision is usually very small and the scar almost unappreciable. However, in the case of the large core biopsy device (0.5 to 2.0 cm), a large incision is needed. Such a large incision often results in a non-aesthetically placed scar.

[0020] The newer conventional minimally invasive breast biopsy devices have improved in some ways the ability to diagnose mammographically detected nonpalpable lesions. These devices give the patient a choice as to how she wants the diagnosis to be made. Moreover, these devices are substantially less expensive than the older traditional needle-localized breast biopsy. They are not, however, the final solution. Due to the above-discussed problems and risks associated with compression, needle-track seeding, blood borne metastases, bleeding, radiation exposure and awkwardness of the stereotactic table, more refined devices and methods are needed to resolve these issues. Also, the conventional biopsy devices do not consider margins in their excisions and if cancer is diagnosed, the patient must undergo a needle-localized breast lumpectomy to ensure that adequate margins are removed around the cancer. Devices and methods, therefore, must address the problem of obtaining adequate margins so that a second procedure is not required. Margins, moreover, cannot be assessed while the breast is being compressed.

[0021] Commonly assigned U.S. Pat. No. 6,022,362, discloses a novel approach to soft tissue excisional devices. As

disclosed therein, the excisional device includes independently actuatable cutting and collection tools. As shown therein, the device may include a cutting tool attached near the distal tip of the device. At least a distal portion of the cutting tool is configured to selectively bow out of the window and to retract within the window. One embodiment of the device described in this patent also includes an independently actuatable tissue collection device that is separate from the cutting device and that is also externally attached near the distal end of the device. In this configuration, the tissue collection device independently collects the tissue severed by the cutting tool as the excisional is rotated and the cutting tool is independently bowed.

#### SUMMARY OF THE INVENTION

[0022] The present invention, according to one embodiment thereof, is a method of removing breast tissue. The method may include steps of providing a tissue cutting device having an elongate cutting element coupled to a shaft, the cutting element being movable between a bowed position and a retracted position, wherein a deployed part of the cutting element lies outside the shaft when in the bowed position, the deployed part of the cutting element having a cutting side which penetrates the tissue as the shaft is rotated; introducing the tissue cutting device into a breast; coupling a power source to the elongate cutting element; moving the elongate cutting element to the bowed position so that the deployed part of the cutting element lies outside the shaft; preventing energy from being transmitted from a portion of the deployed part of the cutting element for cutting to the tissue while the elongate cutting element is in the bowed position; and rotating the cutting device so that the cutting side of the bowed cutting element penetrates the breast tissue to cut the breast tissue for removal.

[0023] The preventing step may be carried out by preventing energy from being transmitted from a radially inner portion of the cutting element to the tissue. The preventing step may be carried out by partially covering the deployed part of the cutting element. Alternatively, the preventing step may be carried out by partially covering the deployed part of the cutting element with insulation which may prevent transmission of energy to the tissue. Alternatively still, the preventing step may be carried out by covering the deployed part of the cutting element with an element which may be also movable between bowed and retracted positions. The preventing step may be carried out with the element positioned adjacent a radially inner side of the cutting element. The preventing step may be carried out with a tissue collection element preventing contact between the tissue and the portion of the cutting element; and the rotating step may be carried out to sever tissue which may be collected by the tissue collection element. Or, the preventing step may be carried out with the portion of the cutting element not transmitting energy being primarily on a trailing side of the cutting element.

[0024] According to another embodiment thereof, the present invention is a device for removing tissue, comprising a shaft; a cutting element coupled to the shaft, the cutting element being movable between a bowed position and a retracted position, a deployed part of the cutting element lies outside the shaft when in the bowed position, the deployed part of the cutting element having a cutting side which penetrates the tissue as the shaft may be rotated, the cutting

element having means for preventing energy for cutting tissue from being transmitted from a portion of the deployed part of the bowed cutting element to the tissue.

[0025] The preventing means may prevent energy from being transmitted from a radially inner portion of the cutting element to the tissue. The preventing means partially may cover the deployed part of the cutting element. The preventing means may include insulation which partially may cover the deployed part of the cutting element. Alternatively, the preventing means may cover the deployed part of the cutting element with an element which may be also movable between bowed and retracted positions. The preventing means may include an element positioned adjacent a radially inner side of the cutting element. According to still another embodiment, the preventing means may include a tissue collection element which may prevent contact between the tissue being cut and the portion of the cutting element, the tissue collection element collecting the tissue being cut by the cutting element. The preventing step means may prevent transmission of energy to the tissue primarily from a trailing side of the cutting element which may be opposite the cutting side.

[0026] According to another embodiment, the present invention is a device for removing breast tissue, comprising: a shaft; a cutting element mounted to the shaft, the cutting element being movable between a bowed position and a straightened position, the cutting element bowing outward away from the shaft when in the bowed position, the cutting element having an elongate cutting side which cuts tissue when the shaft may be rotated, the cutting element having a length which may be at least 25 times larger than a width of the cutting element.

[0027] The cutting element may have an exposed surface area for transmitting energy to the tissue being cut, the exposed surface area including a radially inner part and a radially outer part, the radially outer part being larger than the radially inner part. Only one cutting element may be mounted to the shaft. The cutting element may have a rectangular cross-sectional shape. The device may also include a tissue collection element coupled to at least one of the cutting element and the shaft, the tissue collection element collecting tissue which may be severed by the cutting element. The length of the cutting element may be at least 40 times larger than the width of the cutting element, for example. The length of the cutting element may be at least 100 times larger than the width of the cutting element, for example. The cutting element may have an effective width that is less than the width of the cutting element, the effective width being a width which is exposed for contact with the tissue being cut to transmit cutting energy to the tissue. The length of the cutting element may be at least 25 times larger than the effective width.

[0028] The present invention, according to yet another embodiment thereof, is a method of cutting breast tissue for removal, comprising the steps of: providing a tissue cutting device having an elongate cutting element, the cutting element being movable between a bowed position and a retracted position, the cutting element having a radially outer side and a radially inner side; introducing the tissue cutting device into a breast; moving the elongate cutting element to the bowed position; coupling a power source to the elongate cutting element; and rotating the cutting ele-

ment after the moving step so that the cutting element cuts the breast tissue, the radially outer side has a larger surface area for transmitting energy to cut the tissue than the radially inner side.

[0029] The rotating step may be carried out with the radially outer side having an exposed part for transmitting energy to the tissue which may be at least 20% larger than an exposed part of radially inner side for transmitting energy to the tissue. The rotating step may be carried out with the radially outer side having an exposed part for transmitting energy to the tissue which may be at least 35% larger than an exposed part of radially inner side for transmitting energy to the tissue. The rotating step may be carried out while partially covering at least part of the radially inner side of the cutting element. The rotating step may be carried out with a cover positioned adjacent the cutting element, the cover also being movable between bowed and retracted positions. The preventing step may be carried out with the cover positioned adjacent a radially inner side of the cutting element. The preventing step may be carried out with the portion of the cutting element not transmitting energy to the tissue being primarily on a trailing side of the cutting element. The preventing step may be carried out with a tissue collection element preventing contact between the tissue and the portion of the cutting element; and the rotating step may be carried out to sever tissue which may be collected by the tissue collection element. The preventing step may be carried out by insulating part of the deployed part of the cutting element to prevent transmission of energy to the tissue.

[0030] Another embodiment of the present invention is a device for cutting breast tissue for removal, comprising: a shaft; and an elongate cutting element mounted to the shaft, the cutting element being movable between a bowed position and a retracted position, the cutting element having a radially outer side and a radially inner side, the radially outer side has a larger surface area for transmitting energy to cut the tissue than the radially inner side.

[0031] The radially outer side may have an exposed part for transmitting energy to the tissue which may be at least 20% larger than an exposed part of radially inner side for transmitting energy to the tissue. The radially outer side may have an exposed part for transmitting energy to the tissue which may be at least 35% larger than an exposed part of radially inner side for transmitting energy to the tissue. The radially inner side of the cutting element may be partially covered. The radially inner side may be covered by a cover positioned adjacent the cutting element, the cover also being movable between bowed and retracted positions. The partially covered portion of the cutting element may be on a trailing side of the cutting element. The device may also include a tissue collection element for collecting tissue severed by the cutting element. The cutting element may have a deployed part lying outside the shaft in the bowed position, and at least part of the cutting element may be covered with insulation.

[0032] The present invention, according to yet another embodiment, is a device for cutting and collecting a specimen from a mass of tissue, comprising: an integrated cut and collect assembly, the integrated cut and collect assembly including a cutting portion and a collection portion that may include a flexible membrane, the collection portion being attached to the cutting portion, the cutting portion being

configured to cut the specimen from the mass of tissue and the collection portion being configured to collect the cut specimen and to isolate the cut specimen within the membrane.

[0033] According to another embodiment, a method of cutting and isolating a specimen from a mass of tissue may include steps of inserting an instrument that may include an integrated cut and collect assembly into the mass of tissue, the integrated cut and collect assembly including a cutting portion and a collection portion that may include a thin flexible membrane, the collection portion being attached to the cutting portion, the cutting portion being configured to cut the specimen from the mass of tissue and the collection portion being configured to collect the cut specimen from the mass of tissue and to isolate the cut specimen from the mass of tissue within the membrane, and isolating the specimen from surrounding tissue by cutting the specimen from the mass of tissue with the cutting portion and collecting the cut specimen within the flexible membrane of the collecting portion.

[0034] A device for cutting and collecting a specimen from a mass of tissue may include a shaft defining a proximal and a distal end; a work assembly near the distal end of the shaft, the work assembly being configured to cut the specimen from the mass of soft tissue and to isolate the cut specimen from surrounding tissue; a single actuator near the proximal end of the shaft, the single actuator being mechanically coupled to the work assembly such that rotation of the device and operation of the single actuator may be effective to cut, collect and isolate the specimen from the mass of tissue as the device may be rotated.

[0035] Another embodiment is a method of collecting a tissue specimen from a mass of tissue, comprising the steps of: inserting a surgical instrument into the mass of tissue to a target location within the mass of tissue, the instrument including a shaft and a work assembly near a distal end of the shaft, the work assembly being configured to controllably cut the specimen from the mass of soft tissue and to isolate the cut specimen from the mass of tissue within a tissue isolator; controlling the work assembly of the surgical instrument to cut and isolate the specimen, and retracting the instrument from the mass of tissue while the specimen may be isolated within the tissue isolator and at least partially trails the distal end of the shaft.

[0036] Lastly, a surgical instrument for retrieving a tissue specimen from a mass of tissue may include a shaft defining a proximal and a distal end, and a work assembly coupled to the shaft near the distal end thereof, the work assembly including: a tissue cutting portion configured to cut the tissue specimen from the mass of tissue; a tissue collection portion that may include a membrane, the membrane being configured to encapsulate and isolate the cut specimen from the mass of tissue and being adapted to stretch to enable the encapsulated specimen to at least partially trail the distal end of the shaft as the surgical instrument may be retracted from the mass of tissue.

#### BRIEF DESCRIPTION OF THE DRAWINGS

[0037] For a further understanding of the objects and advantages of the present invention, reference should be made to the following detailed description, taken in conjunction with the accompanying figures, in which:



[0038] **FIG. 1A** is perspective view of an excisional device according to an embodiment of the present invention.

[0039] **FIG. 1B** is a partial enlarged view of the excisional device of **FIG. 1A**, in which the integrated cut and collect assembly thereof is in an expanded configuration.

[0040] **FIG. 1C** shows the device of **FIG. 1B** with an element for retracting tissue away from the ribbon **116**.

[0041] **FIG. 2A** is a cross-sectional side view of an excisional device according to an embodiment of the present invention.

[0042] **FIG. 2B** is a perspective view of a portion of the integrated cut and collect assembly of **FIG. 2A**.

[0043] **FIG. 2C** is a perspective view of the collection portion of the integrated cut and collect assembly, showing the manner in which the flexible membrane may be attached to the assembly and the outer surface of the shaft of the present excisional device, according to an embodiment of the present invention.

[0044] **FIG. 2D** is a cross-sectional view showing the relative positions of the ribbons.

[0045] **FIG. 2E** shows an alternative view of **FIG. 2D** along the cross-section of **FIG. 1B**.

[0046] **FIG. 2F** shows another alternative view of **FIG. 2D**.

[0047] **FIG. 3** is a perspective view of an excisional device according to an embodiment of the present invention, with the integrated cut and collect assembly in the retracted position.

[0048] **FIG. 4** shows the excisional device of **FIG. 3**, with the integrated cut and collect assembly in an expanded position.

[0049] **FIG. 5** shows the excisional device of **FIG. 3**, with the integrated cut and collect assembly in a fully expanded position.

[0050] **FIG. 6** shows an exemplary configuration of the integrated cut and collect assembly of the present invention, detailing the manner in which the collecting portion may be attached to the cutting portion of the integrated cut and collect assembly.

[0051] **FIG. 7** shows another exemplary configuration of the integrated cut and collect assembly of the present invention.

[0052] **FIG. 8A** shows yet another exemplary configuration of the integrated cut and collect assembly of the present invention, detailing the manner in which the collecting portion may be attached to the cutting portion of the integrated cut and collect assembly.

[0053] **FIG. 8B** shows still another exemplary configuration of the integrated cut and collect assembly of the present invention, detailing the manner in which the collecting portion may be attached to the cutting portion of the integrated cut and collect assembly.

[0054] **FIG. 8C** shows a perspective and a cross sectional view of still another exemplary configuration of the integrated cut and collect assembly of the present invention.

[0055] **FIG. 8D** shows yet another exemplary configuration of the integrated cut and collect assembly of the present invention, detailing the manner in which the collecting portion may be attached to the cutting portion of the integrated cut and collect assembly.

[0056] **FIG. 8E** shows a still further exemplary configuration of the integrated cut and collect assembly of the present invention.

[0057] **FIG. 9** illustrates aspects of the present method for cutting and collecting a tissue specimen from a mass of tissue, according to an embodiment of the present invention.

[0058] **FIG. 10** illustrates further aspects of the present method for cutting and collecting a tissue specimen from a mass of tissue, according to an embodiment of the present invention.

[0059] **FIG. 11** illustrates still further aspects of the present method for cutting and collecting a tissue specimen from a mass of tissue, according to an embodiment of the present invention.

[0060] **FIG. 12** illustrates further aspects of the present method for cutting and collecting a tissue specimen from a mass of tissue, according to an embodiment of the present invention.

[0061] **FIG. 13** illustrates further aspects of the present method for cutting and collecting a tissue specimen from a mass of tissue, according to an embodiment of the present invention.

[0062] **FIG. 14** illustrates further aspects of the present method for cutting and collecting a tissue specimen from a mass of tissue, according to an embodiment of the present invention in which the collected and isolated (encapsulated) tissue specimen trails the distal tip of the excisional device as it is retracted from the tissue.

[0063] **FIG. 15** illustrates further aspects of the present method for cutting and collecting a tissue specimen from a mass of tissue, according to another embodiment of the present invention in which the collected and isolated tissue specimen trails the distal end of the excisional device as it is retracted from the tissue.

[0064] **FIG. 16** illustrates still further aspects of the present method for cutting and collecting a tissue specimen from a mass of tissue, in which the excisional device containing the tissue specimen has been fully removed from the tissue mass from which the specimen was cut, collected and isolated.

#### DESCRIPTION OF THE INVENTION

[0065] **FIG. 1A** is a perspective view of an excisional device according to an embodiment of the present invention. As shown, the excisional device **100** includes a proximal section **102** that may be configured to fit the physician's hand. Extending from the proximal section **102** is a shaft **104** that may be terminated by a distal tip **106**. However, an introducer may be used for the initial incision, whereupon the tip **106** may be omitted from the device **100**. The distal tip **106** is configured so as to easily penetrate a mass of tissue, and may feature curvilinear cutting surfaces (best seen in **FIG. 1B**). The distal tip **106** may be configured to be energized by a radio frequency (RF) energy source, supplied

via the electrical cord 122. However, the distal tip 106 need not be energized, as the sharpness of the cutting surfaces of the distal tip 106 is generally sufficient to easily penetrate the tissue to the target excision site. The distal tip 106 may be configured to be retractable and extendable, so as to reduce trauma. An integrated cut and collect assembly 108 is mounted near the distal tip 106 or near the distal most portion of the shaft 104. According to the present invention, the integrated cutting and collection assembly 108 is configured to cut a tissue specimen (a piece of tissue or a lesion) from the mass of tissue (such as, for example, breast tissue), to collect the cut specimen and to isolate the cut specimen from the surrounding tissue by, for example, encapsulating the same within a flexible bag-shaped membrane. Although the present invention finds advantageous utility in terms of excisional procedures on the female breast, it is understood that the present invention is not limited thereto. Indeed, the present methods and devices may be advantageously employed and deployed within most any mass of soft tissue. Moreover, although the present excisional device described and shown herein is presented as a hand held excisional device, it is to be understood that the proximal section 102 may be suitably modified to fit within a stereotactic unit for automated, semi-automated or manual operation.

[0066] According to the present invention, the integrated cut and collect assembly 108 includes a cutting portion and a collection portion that includes a flexible membrane 114. The collection portion of integrated cut and collect assembly 108 is attached to the cutting portion. As shown most clearly in FIG. 1B, the collection portion may be attached to the cutting portion, according to an embodiment of the present invention, by a small ring member 124 encircling both the cutting portion and part of the collecting portion so as to insure that the cutting and collection portions of the integrated cut and collect assembly 108 move together. As noted above, the cutting portion is configured to cut the specimen from the mass of tissue and the collection portion is configured to collect the cut specimen and to isolate the cut specimen from surrounding tissue. This isolation from surrounding tissue, according to the present invention, is carried out by a flexible membrane 114 that forms a part of the collecting portion of the integrated cut and collect assembly 108, as described in detail below.

[0067] The integrated cut and collect assembly 108 may be mechanically coupled to an actuator 112 such that operation of the actuator 112 causes a deployment of the integrated cut and collect assembly 108 from the retracted position shown in FIG. 1A in which the integrated cut and collect assembly 108 is at least partially retracted within a trough 120 defined within the shaft 104 to a selectable expanded position away from the shaft 104, as shown in FIG. 1B. For example, by pushing the actuator 112 in the distal direction (i.e., toward the distal tip 106), the integrated cut and collect assembly 108 transitions from the retracted position shown in FIG. 1A to a selectable variable expanded position illustrated in FIG. 1B in which the integrated cut and collect assembly 108 bows out radially relative to the longitudinal axis of the shaft 104 (i.e., in the direction of arrow 110 in FIG. 1A). The degree of bowing (expansion) of the integrated cut and collect assembly 108 depends upon the travel imposed upon the actuator 112 by the physician. In this manner, the physician may match the degree of expansion of the integrated cut and collect assembly 108 to the size of the targeted lesion or the size of the desired

specimen within the mass of tissue. The degree of expansion may be varied at will during the excisional procedure by means of direct observation by means of ultrasound or some other imaging or guidance modality disposed within the shaft 104 or external to the device 100.

[0068] The cutting portion may include a ribbon 116 that is pushed out of the trough 120 to assume the bowed shape of FIG. 1B. The ribbon may be energized by an RF energy source so as to efficiently cut the specimen from the mass of tissue. A standard, off the shelf and widely available RF generator, such as a ValleyLab Force FX Generator from ValleyLab of Boulder, Colo. may advantageously be used to energize the cutting portion of the integrated cut and collect assembly 108 of the present invention, although other RF generators may also be employed to energize the cutting portion of the integrated cut and collect assembly 108 and/or the tip 106 described herein. As the excisional device is rotated during the cutting of the specimen, the ribbon 116 of the cutting portion preferably forms the leading edge of the integrated cut and collect assembly 108. The collecting portion of the integrated cut and collect assembly 108 may also include a ribbon that is mechanically coupled to the cutting portion thereof, shown in FIG. 1B at reference numeral 118. The ribbon 118 of the collecting portion may at least partially overlap the ribbon 116 of the cutting portion. Attached to the collecting ribbon 118 and/or to the ribbon 116 of the cutting portion is a flexible membrane 114, which serves to collect and to isolate the collected specimen by drawing over the cut specimen and encapsulating same. The flexible membrane 114 may be shaped as a bag (a container that is closed on all sides except a selectively openable and closable opening) whose opening may be attached to both the shaft 104 and the collecting ribbon 118 and/or the ribbon 116 of the cutting portion of the integrated cut and collect assembly 108. Although the embodiment of the present invention shown in FIGS. 1A and 1B includes a cutting ribbon 116 and a collecting ribbon 118, both ribbons are expanded and retracted substantially simultaneously as they are mechanically coupled to one another to form the integrated cut and collect assembly 108, a single mechanical expandable and retractable loop. Alternatively, only a single ribbon may be present and the flexible membrane attached directly to such single ribbon, as detailed herein below. By virtue of this configuration, when the integrated cut and collect assembly 108 is in the expanded position (FIG. 1B), the bag is in an open configuration in which the tissue cut by the cutting portion is received and collected in the bag formed by the flexible membrane 114 as the device is rotated. However, when the integrated cut and collect assembly 108 is in the retracted position (FIG. 1A), the opening of the bag formed by the flexible membrane 114 is pinched shut or substantially shut, thereby trapping and encapsulating the collected specimen therein and isolating (or substantially isolating) the collected specimen from the surrounding tissue.

[0069] FIG. 2A is a cross-sectional side view of an excisional device according to an embodiment of the present invention. As shown, the actuator 112 may be mechanically coupled to the integrated cut and collect assembly 108 so that when the actuator is pushed in the proximal direction, the integrated cut and collect assembly 108 retracts within the trough 120 defined within the shaft 104. Conversely, when the actuator 112 is pushed in the distal direction, the integrated cut and collect assembly 108 is pushed out of the

trough 120 and expands out of the trough 120 to assume the bowed shape shown in FIG. 2A. The ribbon or ribbons of the integrated cut and collect assembly 108 may extend back to the actuator 112 through a first lumen 204 defined within the shaft 104 and may be attached to the actuator 112 to thereby enable movement of the actuator 112 to expand and retract the integrated cut and collect assembly 108. Alternatively, the ribbon 118 of the collecting portion of the integrated cut and collect assembly 108 may only extend a fraction of the length of the cutting ribbon 116. However, as the two ribbons are mechanically coupled to one another, expansion of the cutting ribbon 116 causes the simultaneous expansion of the collecting ribbon 118 without the collecting ribbon 118 being directly attached to the actuator 112.

[0070] A second lumen 206 may also be defined within the shaft 104. The second lumen 206 may be used, for example, to evacuate smoke and/or bodily fluids from the excision site within the mass of tissue. Alternatively the second lumen 206 defined within the shaft 104 may be used to deliver a pharmaceutical agent to the excisional site, such as, for example, an anesthetic, an analgesic and/or some other agent. Other uses may be found for such lumen. An inflatable balloon 208 may be coupled to the shaft 104. The balloon 208 may be inflated with, for example, a gas (air, an inert gas or carbon dioxide, for example) or a fluid such as saline. The balloon may serve several functions. For example, the balloon 208 may be configured to massage the mass of tissue by pulsating the inflation of the balloon, may be configured as a cooling sleeve, may be configured as a tissue expander, may be configured to stabilize the device when inserted in tissue, may be configured to seal the incision through which the device is inserted, to provide hemostasis, and/or to reduce capacitive coupling to reduce tissue heating. The balloon 208 may be inflated from a lumen defined within the excisional device and supplied to the device via a suitable port defined in the proximal end of the device. The actuator 112 may define one or more protrusions 212 and an interior surface of the device may include corresponding crenellations that are collectively and cooperatively configured to provide a number of set stops to the actuator 112 along its travel path and optionally a tactile feedback for the physician, who can set the integrated cut and collect assembly 108 to predetermined degrees of expansion without looking at the device during the excisional procedure. Indeed, during the procedure, as the physician expands the integrated cut and collect assembly 108, he or she will feel periodic increases in resistance followed by a tactile and/or audible release as the protrusions 212 slip into the crenellations 210.

[0071] FIG. 2B is a perspective view of a detail of the integrated cut and collect assembly 108 of FIG. 2A. According to this embodiment, the cutting ribbon includes a first cutter ribbon 116A and a second cutter ribbon 116B that may be welded (or otherwise attached) to the first cutter ribbon 116A, as shown by weld 224. Together, the first cutter ribbon 116A and the second cutter ribbon 116B constitute the leading (and cutting) edge of the integrated cut and collect assembly 108. Behind this leading edge is the collecting portion of the integrated cut and collect assembly 108. Specifically, behind the leading edge of the cutting portion is disposed the ribbon 118 to which the flexible membrane 114 is attached. The ribbon 118 to which the flexible membrane 114 is attached may also be welded (or otherwise attached) to the first cutter ribbon 116A, as also shown at

224. The first ribbon 116A may be relatively wider than the second ribbon 116B, so as to completely overlap both the second ribbon 116B and the ribbon 118 to which the flexible membrane 114 is attached. This gives the integrated cut and collect assembly 108 necessary rigidity, while allowing the second ribbon 116B and the ribbon 118 to be reduced in size, thereby reducing space and bulk. The three ribbons 116A, 116B and 118 are preferably kept at a voltage equipotential, so as to decrease the possibility of arcing when RF power is applied to the integrated cut and collect assembly 108. According to an advantageous embodiment of the present invention, only the first ribbon 116A need be coupled to the actuator 112. As the second ribbon 116B and the ribbon 118 are mechanically coupled to the first ribbon 116A, they will move in unison with the first ribbon 116A as the actuator 112 is moved by the physician or the stereotactic unit to which the device 100 may be coupled. The device may, of course, omit one of the ribbons 116A, 116B such as ribbon 116B as shown in FIGS. 2E and 2F leaving only ribbon 116A for cutting tissue. The description of ribbon 116 as used herein shall apply to ribbon 116A and/or ribbon 116B as shown in FIGS. 2C, 2E and 2F as applicable.

[0072] FIG. 2C is a perspective view of the collection portion of the integrated cut and collect assembly, showing the manner in which the flexible membrane 114 may be attached within the assembly 108 and to the outer surface of the shaft 104 of the present excisional device 100, according to an embodiment of the present invention. As shown therein, the flexible membrane 114 may include a lumen forming portion 224 through which the ribbon 118 (see FIG. 2B) is inserted, to provide rigidity to the mouth or opening 222 of the collecting portion of the integrated cut and collect assembly 108. The ribbon 118 is attached to the cutting ribbon 116 (116A, 116B) so as to expand and retract therewith under the action of the actuator 112. The flexible membrane 114 also includes a shaft attachment tab 220, which is configured to attach the flexible membrane 114 to the shaft 104 of the present excisional device. For example, the shaft attachment tab 220 may be attached to the shaft 104 through a mechanically and biologically appropriate adhesive. The remainder of the flexible membrane 114 may be shaped as a bag, the opening or mouth 222 thereof being delimited by the shaft attachment tab 220 and the lumen forming portion 225 through which the ribbon 118 runs. Therefore, when the actuator 112 causes the integrated cut and collect assembly 108 to expand, the opening 222 of the integrated cut and collect assembly 108 is opened and when the actuator 112 causes the integrated cut and collect assembly 108 to retract at least partially within the shaft 104, the mouth 222 of the bag formed by the flexible membrane 114 closes, effectively encapsulating and isolating whatever tissue, specimen or lesion has been cut and collected therein. The tissue is isolated, as the lumen forming portion 224, when the integrated cut and collect assembly 108 is in the retracted state, may be pressed against the shaft 104, thereby interposing a layer of the flexible membrane 114 between the collected tissue and the surrounding tissue.

[0073] As an alternative, the flexible membrane 114 may be attached to an exterior surface of the device 100 and to a tube defining a lumen running at least a portion of the length of the second ribbon 118. The flexible membrane may be attached thereto by means of an adhesive, for example. Other means and structures for attaching the flexible mem-

brane 114 to the cutting portion of the integrated cut and collect assembly 108 are disclosed herein below.

[0074] FIG. 2D is a perspective view of a shaft 104 of the present excisional device, showing further aspects thereof. As shown therein, the shaft 104 defines a trough 120 near the distal end thereof. Preferably, the trough 120 includes a ledge portion 121 that is cut out of the shaft 104. The ledge 121 allows additional room to accommodate the membrane 114 when the integrated cut and collect assembly 108 retracts within the trough 120. The ledge 121 within the trough 120 enables the integrated cut and collect assembly 108 to more fully retract within the trough 120 than would otherwise be possible without the ledge 121 by providing additional space for the membrane 114. Without the ledge 121, the bulk of the membrane 114 could hamper the full retraction of the integrated cut and collect assembly 108 into the trough 120. The integrated cut and collect assembly 108 is preferably at least partially retracted within the trough 120 when the cutting portion thereof is first energized, prior to initiating cutting of tissue. This separates the tissue to be cut from the cutting portion of the integrated cut and collect assembly 108 until the assembly has been sufficiently energized to efficiently cut through the tissue. The trough 120 is also instrumental in allowing the present excisional device to utilize a standard RF generator (e.g., one that does not rely upon feedback from an impedance sensor or the like to vary the applied power), such as the ValleyLab Force FX Generator discussed above. Keeping the integrated cut and collect assembly 108 at least partially retracted within the trough 120 also prevents excessive thermally-induced tissue damage, as all or most of the surface area of the cutting portion of the integrated cut and collect assembly 108 is kept away from the tissue until the cutting portion is fully energized (i.e., until the current density at the cutting portion of the integrated cut and collect assembly 108 is sufficient to initiate and maintain arcing). Other means and structures for enabling the RF cutting portion of the integrated cut and collect assembly 108 are disclosed in commonly assigned and co-pending application Ser. No. 09/732,848, filed Dec. 7, 2000, which application is hereby incorporated herein in its entirety.

[0075] FIGS. 3-5 collectively show the operation of integrated cut and collect assembly of the present excisional device. As shown in FIG. 3, the actuator 112 is in its proximal most position and the integrated cut and collect assembly 108 mechanically coupled thereto is in the substantially retracted position wherein both the cutting and collecting portions thereof are at least partially retracted within through 120 defined within the shaft 104. The flexible membrane 114 of the collecting portion may initially be folded, (at least partially) stowed in the trough 120 defined within the shaft 104, or simply loose. As the membrane 114 is preferably thin, smooth and flexible, it does not significantly hamper the insertion of the instrument as it penetrates the tissue mass. As shown in FIG. 4, sliding the actuator 112 in the distal direction causes the integrated cut and collect assembly 108 to expand in the direction shown by arrow 110. This expansion causes the cutting portion of the assembly 108 to bow radially out from the shaft 104 and the deployment of the flexible membrane 114 of the collecting portion. As the flexible membrane 114 is attached both to the outer surface of the shaft 104 and to the integrated cut and collect assembly 108, expansion of the integrated cut and collect assembly 108 opens the mouth of the bag shaped

flexible membrane 114 and retraction thereof (FIG. 3) closes the mouth thereof. FIG. 4 shows the device 100 in a configuration wherein the actuator 112 is engaged to its distal most position and the integrated cut and collect assembly 108 is fully expanded. By varying the position of the actuator 112, the physician may achieve a fine grained control over the deployment of the integrated cut and collect assembly 108 to suit even an irregularly-shaped and sized specimen or lesion to be cut, collected, isolated and retrieved.

[0076] The integrated cut and collect assembly 108, according to the present invention, may include one or more mechanically coupled ribbons or wires. For example, the device 100 may include a first ribbon 116 of the cutting portion and a second ribbon 118 to which the flexible membrane 114 is attached. Alternatively, the flexible membrane 114 may be attached to a trailing edge of the ribbon 116 of the cutting portion of the integrated cut and collect assembly 108. In such an embodiment, the integrated cut and collect assembly 108 does not include separate but mechanically coupled cutting and collecting portions, but instead includes only a single ribbon 116 or other (RF) cutting element to which the flexible membrane 114 is attached. Other methods and means of attaching the flexible membrane to the cutting portion are disclosed hereunder. Such methods and means may draw upon the physical mechanical structure of the cutting portion, the collecting portion, the ribbon 116 and/or 118 and the material of the flexible membrane 114.

[0077] FIG. 6 shows an exemplary configuration of the integrated cut and collect assembly of the present invention, detailing one possible manner in which the collecting portion may be attached to the cutting portion of the integrated cut and collect assembly 108. As shown therein, the integrated cut and collect assembly 108 may include only a single ribbon 116. This single ribbon 116 forms the cutting portion of the assembly 108. According to this embodiment, the ribbon 116 may be configured as a flexible tube with a longitudinal slit 606 through which the flexible membrane 114 emerges. The flexible membrane 114, according to this embodiment, may include a locally thicker (bulbous, for example) portion 602 that is disposed within the interior lumen 608 defined by the tube-shaped ribbon 116. The slit 606 is oriented such that the flexible membrane 114 extends out of the trailing edge 612 of the ribbon 116. As the ribbon 116 is expanded and energized and the excisional device 100 rotated, the leading edge 610 of the ribbon 116 cuts through the tissue, while the flexible membrane 114 is deployed and trails behind, collecting, isolating and encapsulating the cut tissue. The ribbon 116 need not be shaped as a tube, but may assume any shape that efficiently cuts through the tissue and secures the flexible membrane 114 thereto. Moreover, the ribbon need not completely encircle the locally thicker portion 602 of the flexible membrane 114. The ribbon 116 may be advantageously formed of a conductive and resilient material such as stainless steel, titanium, tungsten or a shape memory metal, such as a nickel titanium alloy sold under the name of Nitinol®, for example.

[0078] As an alternative to the solid ribbon 116, the cutting portion of the integrated cut and collect assembly 108 may include or be formed of a plurality of wires or ribbons braided in such a manner as to form the tissue cutting ribbon, as shown at 702 in FIG. 7. To provide additional rigidity, a

central reinforcing ribbon or mandrel **704** may be disposed within the interior lumen formed by the braided ribbon **702**. As shown in **FIG. 7**, the locally thicker portion **706** of the flexible membrane **114** may be formed around the central reinforcing ribbon **704**.

[0079] **FIG. 8A** shows another embodiment of the integrated cut and collect assembly **108**. As shown, the flexible membrane **114** of the collecting portion may be sandwiched between two flexible plates **806**, **808**. Rivets, pins and/or welds **808** secure the two plates **804**, **806** to one another with the flexible membrane **114** therebetween. The plates **804**, **806** are preferably sufficiently flexible to selectively assume the retracted shape and the expanded and bowed shape of the integrated cut and collect assembly **108**, as shown in **FIGS. 3 and 5**, respectively. The assembly of **FIG. 8A** may also include a solid or braided conductive (shown) ribbon or wire **802**. The ribbon **802** may also be sandwiched between the two plates **804**, **806** and held securely in place. In this case, the ribbon **802** defines the leading edge of the integrated cut and collect assembly **108** and the flexible membrane **114** the trailing edge thereof. The plates **804**, **806** and the rivets, welds or pins **808** may be formed of a conductive material. In that case, when the ribbon **802** is energized with RF energy, the ribbon **802** and the plates **804**, **806** are at a same voltage potential, which prevents or decreases the probability of arcing between the plates **804**, **806** and the ribbon **802**. Alternatively, only the wire or ribbon **802** may be formed of a conductive material and the plates **804**, **806** and the rivets, welds or pins formed of an insulating material. In this case, only then wire or ribbon **802** is energized and cuts through the tissue.

[0080] **FIG. 8B** shows yet another embodiment of the integrated cut and collect assembly **108**, in which the collecting portion is directly attached to the cutting portion thereof. As shown therein, the cutting portion of the integrated cut and collect assembly **108** may include a windowed conductive plate **802**. This conductive (metal, for example) plate **820** is preferably a thin plate in which openings **822** are defined. The thin plate **820**, according to this embodiment, forms the cutting portion of the integrated cut and collect assembly **108**. This cutting portion may be formed by bending the plate **820** along the longitudinal axis **824** to secure the flexible membrane **114** between the free edges thereof. The leading edge of the integrated cut and collect assembly **108**, therefore, may be formed by the bent plate **820** whereas the trailing edge thereof includes the flexible membrane **114**. The openings **822** in the plate **820** may facilitate the bending thereof, so as to allow the flexible membrane **114** to be securely attached thereto. Crimping of the free edges of the plate **820** and/or an adhesive may be used to secure the flexible membrane **114** to the plate **820**. The windows or openings **822** may be defined within the plate **820** by stamping, through a photoetching technique or by cutting, as those of skill in this art will recognize.

[0081] **FIG. 8C** shows a perspective and a cross sectional view of still another exemplary configuration of the integrated cut and collect assembly of the present invention. As shown therein, the cutting portion of the integrated cut and collect assembly **108** may be an elliptical cylinder that defines an interior lumen **853**. The cutting portion **824** may be energized with RF energy, as discussed above. A mandrel **854** may be disposed within the cutting portion **824**. A slot **828** is defined only within the trailing edge **858**, and not

within the leading (cutting) edge **860** of the cutting portion **851** of the integrated cut and collect assembly **108**. The flexible membrane **114** loops around the mandrel and emerges from the cutting portion **824** from the slot **828**. The flexible membrane **114** may be bonded at **862** after looping around the mandrel **854**. Alternatively, the mandrel **854** may be inserted in a lumen formed by the flexible membrane **114**. As with the other embodiments discussed relative to **FIGS. 6, 7 and 8**, the flexible membrane may also be attached to the outer surface of the shaft **104** by means of a tab, such as shown at reference numeral **220** in **FIG. 2C**, so as to allow the bag-shaped flexible membrane **114** to selectively open and close upon being acted upon by actuator **112**.

[0082] **FIG. 8D** shows yet another exemplary configuration of the integrated cut and collect assembly of the present invention, detailing the manner in which the collecting portion may be attached to the cutting portion of the integrated cut and collect assembly. As shown therein, the integrated cut and collect assembly **108** may be configured as a single ribbon **876** that defines a cutting portion **872** and a collecting portion **874**. The single ribbon **876** may be split at least along the length of the trough **120** of the shaft **104**. The distal ends of the cutting portion **872** and of the collecting portion **874** may be rejoined or may remain separate. The membrane **114** may define a lumen in which the free end of the collecting portion **874** may be introduced. Alternatively, the membrane **114** may be wrapped around the collecting portion **874** and secured thereto by means of an adhesive. The cutting portion **872** of the single ribbon **876** forms the leading edge of the integrated cut and collect assembly **108** as the device is rotated within the tissue and the specimen cut from the surrounding mass of tissue.

[0083] **FIG. 8E** shows another exemplary configuration of the integrated cut and collect assembly **108** of the present invention. The top figure of **FIG. 8E** shows the integrated cut and collect assembly **108** in the retracted position whereas the bottom figure shows the integrated cut and collect assembly **108** in the expanded position. As shown in the top figure, the membrane **114**, when the integrated cut and collect assembly **108** is in the retracted position, is stretched across the trough **120**. In this embodiment, the cutting portion of the integrated cut and collect assembly **108** may include a cutting ribbon **116** that emerges through the membrane **114** through a first slit therethrough and returns to the trough **120** through a second slit or opening defined therethrough. The cutting ribbon **116**, therefore, is configured to be exposed to the tissue to be cut when the device is inserted within the patient and is located on a first external-facing surface of the membrane **114**. The collecting portion of the integrated cut and collect assembly **108** may also include a collecting ribbon **118** that is located on a second surface of the membrane **114**. The membrane may be attached to the shaft **104** such that when the integrated cut and collect assembly **108** is expanded in the radial direction relative to the shaft **104**, the collecting ribbon **118** stretches the membrane **114** and causes the bag-shaped membrane **114** to define the mouth **222** (see **FIG. 2C**) of the collecting portion. After opening of the mouth or opening **222** by expansion of the integrated cut and collect assembly **108** and the stretching of the membrane **114** and after tissue has been collecting in the membrane **114**, the integrated cut and collect assembly **108** may be retracted at least partially within the trough **120**, causing the membrane **114** to return to the configuration shown in the top drawing of **FIG. 8E**.

That is, the membrane 114 stretches back over the trough 120, thereby at least partially isolating the collected specimen from the surrounding tissue. In this embodiment, the collecting ribbon 118 may not be attached to the membrane 114. Indeed, the collecting ribbon 118 may only act upon the membrane 114 to stretch the membrane 114 open by pushing on it in the radial direction. When the specimen has been collected and the integrated cut and collect assembly integrated cutting and collecting assembly 108 retracted at least partially within the trough 120, the resilient nature of the membrane 114 causes the membrane to stretch back over the trough 120.

[0084] The foregoing has detailed a number of exemplary embodiments of the integrated cut and collect assembly 108. Those of skill in the art, however, may devise other alternative configurations and structures to integrate the cutting and collecting functions of reference numeral 108 into a single, mechanically coupled assembly that is actuable by a single actuator, such as shown at 112. All such alternative configurations, however, are deemed to fall within the purview of the present invention.

[0085] FIGS. 9-16 show aspects of the present method for isolating a tissue specimen from surrounding tissue, according to embodiments of the present invention. As shown in FIG. 9, the excisional device 100 according to an embodiment of the present invention may be inserted through the skin 902 (or through the outermost tissue surface of the mass or organ from which the specimen is to be collected), either by making a prior incision therein or by allowing the distal tip 106 of the device 100 to make the initial cut. The distal tip 106 may be energized with RF energy during the insertion of the device 100 into the mass of tissue 908, but need not be. Satisfactory results are obtained by equipping the distal tip 106 with sharp blades and a conical shape, without the need for an RF energized tip. The integrated cut and collect assembly 108 should be initially in the retracted position, to enable it to readily penetrate the mass of tissue and advance to the target area (in this exemplary case, lesion 904) with the smallest possible profile. The shaft 104 may then be advanced (either through manual physician control or by means of a stereotactic setup) to a position wherein the integrated cut and collect assembly 108 is adjacent the target 904 and the target is approximately positioned in the middle of the integrated cut and collect assembly 108. As shown in FIG. 10, when the integrated cut and collect assembly 108 of the device 100 is positioned adjacent the target lesion 904, the integrated cut and collect assembly 108 may be expanded in the direction indicated by 110 by acting upon the actuator 112, after having fully energized the integrated cut and collect assembly 108 with RF energy, preferably while the integrated cut and collect assembly 108 is at least partially retracted within the trough 120. The integrated cut and collect assembly 108 may be expanded to up to its maximum expansion or to a selectable degree of expansion, advantageously under real time ultrasonic guidance and/or under another imaging modality. As shown at FIG. 11, the present excisional device 100 may then be rotated in the direction indicated by arrow 1102, while the integrated cut and collect assembly 108 remains energized with RF energy. In this manner, the leading edge of the RF-energized integrated cut and collect assembly 108 cuts through the tissue. Preferably the integrated cut and collect assembly 108 is expanded to a sufficient degree so as to cut a margin of healthy tissue around the target lesion 904, so as to decrease

the probability of seeding abnormal cells (e.g., cancerous or pre-cancerous) into and around the excision site and the retraction path. As shown in FIG. 11, as the energized integrated cut and collect assembly 108 is rotated, it cuts around the lesion 904. As the trailing edge of the integrated cut and collect assembly 108 has deployed the collecting portion thereof, the cut lesion or specimen 904 is collected in the open bag formed by the trailing and close ended flexible membrane 114. As shown in FIGS. 12 and 13, the rotation 1102 of the device 100 may be continued as needed (preferably under ultrasonic guidance) until the specimen 904 has been at least partially severed from the surrounding tissue 906. At this point, the specimen 904 has been at least partially collected within the bag-shaped flexible membrane 114 of the collecting portion of the integrated cut and collect assembly 108. As shown at FIG. 14, to fully sever the specimen 904 from the surrounding tissue 906, the integrated cut and collect assembly 108, while still RF energized, may be retracted by acting proximally upon the actuator 112, thus causing the integrated cut and collect assembly 108 to move in the direction 1104 to capture and encapsulate the specimen 904 within the flexible membrane 114. As the bag-shaped flexible membrane is now closed, the cut and collected specimen is effectively isolated and encapsulated (or substantially isolated and encapsulated) from the surrounding tissue 906. Indeed, the cut and collected specimen 904 is now separated from the surrounding tissue by a layer of the flexible membrane 114. The RF to the integrated cut and collect assembly 108 may now be turned off.

[0086] As shown in FIG. 14, the cut, collected, encapsulated and isolated specimen 904 may then be recovered by retracting the device 100 from the mass of tissue 908 by moving the device 100 along the direction indicated at 1106. As shown in FIG. 14, the material of the flexible membrane 114 may be sufficiently elastic so as to allow the cut, collected and physically isolated specimen to stretch so as to at least partially trail the distal tip 106 as the device 100 is retracted along the insertion path through the mass of tissue 908, as shown at 1502 in FIG. 14. By configuring the integrated cut and collect assembly 108 so as to allow the specimen filled bag-shaped flexible membrane 114 to trail the distal tip 106, the initial incision into the skin and the diameter of the insertion and retraction path may be kept small, as neither the retraction path nor the incision need accommodate the full aggregate width of the shaft 104, the integrated cut and collect assembly 108 and the isolated specimen 904.

[0087] As shown in FIG. 15, the specimen-filled flexible membrane of the collecting portion of the integrated cut and collect assembly 108 may be configured so that it does not substantially trail the distal tip, or only does so partially during retraction of the device 100 from the mass of tissue from which the specimen was cut. The material of the flexible membrane 114 (as detailed below) and the configuration thereof may be chosen so as to achieve the desired behavior during the collecting, isolating and retracting phases of the present method. FIG. 16 shows a fully retracted device 100, containing a collected and isolated specimen 904 in which the tissue architecture has been maintained substantially intact. After full retraction of the device 100 from the mass of tissue, the incision within the skin 904 may be treated and closed according to standard surgical practices. During the excisional method detailed relative to FIGS. 9-16, the second lumen 206 (shown in

**FIG. 2A**) within the shaft **104** may be used, for example, to evacuate smoke and/or bodily fluids (e.g., blood) from the excision site within the mass of tissue **908**. Alternatively the second lumen **206** defined within the shaft **104** may be used to deliver a pharmaceutical agent to the excisional site, such as, for example, an anesthetic, an analgesic and/or some other agent. The inflatable balloon **208** shown in **FIG. 2A** may be may be inflated with, for example, a gas (air or carbon dioxide, for example) or a fluid (such as saline, for example). The balloon **208** may assist in stabilizing the present excisional device within the tissue mass after insertion therein and/or to provide some degree of hemostasis during the excisional procedure.

[0088] The flexible membrane **114** is preferably non-conductive and stable at high temperatures. For example, the material used in the flexible membrane should be RF resistant (i.e., have the ability to withstand the temperatures generated by the RF-energized cutting portion of the integrated cut and collect assembly integrated cutting and collecting assembly **108**). The flexible membrane **114**, therefore, should be stable (i.e., acceptably maintains its structural integrity and does not unacceptably melt, deform, burn or lose cohesion, tensile or shear strength) at temperatures at which the energized cutting portion operates. According to one embodiment of the present invention, the flexible membrane includes a non-main chain carbon based polymeric material, such as a silicone elastomer (such as polydimethylsiloxane, for example) or a silicone-containing elastomer. For example, the flexible membrane **114** of the collecting portion of the integrated cut and collect assembly **108** may include one or more of the following materials: an organic, inorganic or organic-inorganic polymer such as a silicone elastomer or a silicone-containing elastomer, a terephthalate, a tetrafluoroethylene, a polytetrafluoroethylene, a polyimide, a polyester, a polyolefin, Kevlar® and/or M5®, for example. The flexible membrane **114** may have a laminar structure that includes one or more reinforcing layers. Such reinforcing layers may include, for example, any of the above-listed materials and/or polyester, polyurethane or polyimide, for example. For example, the flexible membrane **114** may include NuSil 10-6640, a material manufactured by NuSil Technology of Carpinteria, Calif. The thickness of the flexible membrane may be freely chosen according to the desired characteristics of the collecting portion of the integrated cut and collect assembly **108**. For example, the flexible membrane **114** may be between about 0.0005 and about 0.1 inches. For example, the flexible membrane **114** may be chosen to have a thickness between about 0.0007 and 0.005 inches. For example, the flexible membrane **114** may be selected to have a thickness of between 0.001 and 0.015 inches.

[0089] When an adhesive is used to secure the flexible membrane to other structures of the device or the integrated cut and collect assembly **108**, a strong, biologically inert and safe adhesive may be used. Advantageously, a silicone containing or based adhesive or a cyanoacrylate containing or based adhesive may be used with good results.

[0090] In an aspect of the present invention, and as can be appreciated from the description and drawings provided herein, the devices and methods of the present invention may provide for retraction of tissue away from the ribbon **116** which cuts tissue. For example, **FIGS. 1B, 1C, 2B, 2C, 2E** and **2F** show the ribbon **118** holding the membrane **114**

partially or completely covering part of the ribbon **116** such as a radially inner side RI. The ribbon **118** and/or a tissue collection assembly **115** prevents tissue from contacting part of the radially inner RI side of the cutting ribbon **116** and, in particular, the trailing edge TE or trailing side TS of the ribbon **116** opposite the cutting side CS. This feature can provide advantages when starting or re-starting the RF cutting ribbon **116** when the ribbon **116** is already within tissue. By reducing the overall surface area of the RF cutting ribbon **116** that is exposed to tissue, the current density along other parts of the ribbon **116** may be sufficient to start the device using a conventional RF generator, optionally with an increased voltage applied to the ribbon **116**. This cannot be said of many prior art bowed RF cutting elements that provide cutting blades or ribbons exposed on both the radially inner and outer sides. Other means of reducing the surface area of the RF cutting ribbon **116** that is exposed to tissue are disclosed in commonly assigned and copending application Ser. No. 09/732,848, filed Dec. 7, 2000, which application is hereby incorporated herein in its entirety.

[0091] In another method and device of the present invention, the device may have a thickened portion **117** that trails the cutting side CS of the ribbon **116**. The thickened portion **117** retracts tissue away from the ribbon **116** providing the advantage described above. The thickened portion **117** may be at least two or even three times larger than the thickness of the ribbon **116**. The thickened portion **117** may be recessed from the cutting side CS by a distance of less than 0.25 inch or even less than 0.10 inch (**FIG. 2E**) or about 0.015 inch although any configuration may be used. Referring to **FIG. 1B**, the thickened portion is provided by the ribbon **118** and membrane **114** which cover the radially inner side RI of the ribbon **116** through which energy to cut tissue is transmitted. The thickened portion **117** may also simply be provided by the membrane **114** itself or another part of the tissue collection assembly **115**. As the membrane is drawn over the tissue being collected, the collapsed membrane **114** can also retract tissue away from the ribbon **116**.

[0092] Referring to **FIG. 1C**, the device may also provide for retraction of tissue away from the radially outer RO side of the ribbon **116**. The device of **FIG. 1C** is the same as the device of **FIG. 1B** except that the member **124** has been replaced by an element **125** which extends radially outward from the ribbon **116**. The element **125** is essentially a U-shaped sleeve of material having an opening to fit around the trailing side of the ribbon **116**. The sleeve does not transmit RF energy to cut tissue and, in this sense, insulates the ribbon as well as providing retraction away from the cutting side CS. Of course, the element **125** providing retraction of tissue may also transmit RF to cut tissue without departing from various aspects of the invention. The element **125** may be retained by ribbon **116**, ribbon **118**, member **124**, or the tissue collection assembly **115** such as the membrane **114**. Finally, as can be readily appreciated, the ribbon **118** may be separately movable from the ribbon **116** with a separate actuator having similar structure as actuator for ribbon **116** thereby allowing the user to selectively cover parts of the ribbon **116**. In still another aspect of the devices and methods of the present invention, the devices may reduce transmission of energy to cut tissue through parts of the cutting ribbon **116** to the tissue so that the current density is increased at other portions thereof to initiate RF cutting. The tissue retraction devices described above also provide a gap between the ribbon **116** and tissue which can help

initiate RF cutting by providing an ionizing path between the tissue and ribbon. For example, the gap may be simply filled with air, argon, saline or another suitable gas or liquid.

[0093] Another way of preventing transmission of energy from parts of the ribbon 116 to the tissue is to coat the ribbon 116 with a coating 119 such as silicone, ceramic and PTFE. The coating 119 may be applied to any part of the ribbon 116. For example, the trailing side of the ribbon 116 may be coated to essentially coat half the ribbon 116. By coating the ribbon 116 in this manner, half of the cutting ribbon 116 remains exposed for transmitting cutting energy to the tissue. As used herein, the effective width shall mean the part of the ribbon that is exposed to tissue. By coating half the ribbon, for example, the effective width is half the width of the ribbon 116. When partially covering, coating or retracting tissue away from the radially inner and/or radially outer side, one side may have an exposed part which is at least 20% larger, and even 35% larger, than an exposed part of the other side. Of course, the radially outer side may also be completely covered, coated or tissue may be retracted completely away from the radially inner side without departing from numerous aspects of the invention. For example, if the ribbon is recessed only a small amount, such as 0.015 inch, and covered by the membrane 114 the radially inner side will completely covered as shown in FIG. 2F. Finally, other ways of preventing transmission of RF energy to the tissue and/or retracting tissue away from the cutting element can be appreciated from commonly assigned and copending application Ser. No. 10/098,014, filed on Mar. 14, 2002, and commonly assigned and copending application Ser. No. 10/066,428, filed on Jan. 31, 2002, both applications of which are hereby incorporated herein by reference in their entirety.

[0094] In a further aspect of the present invention, the cutting ribbon 116 has an exposed length which cuts tissue which may be 25, 40 or even 100 times larger than the ribbon 116 width or effective width and a length to thickness ratio twice as large. The relatively thin, elongate ribbon 116 maintains sufficient mechanical stability and integrity to sweep through many tissue types. A problem encountered by more robust ribbons known in some prior art is that these ribbons may have difficulty initiating an RF arc within tissue since the ribbons have such large surface areas in contact with tissue. For a given applied voltage, the large surface area reduces the likelihood that the current density will be sufficient to initiate RF cutting using common RF generators. The relatively narrow ribbons of the present invention minimize this problem. Although the ribbon 116 is relatively small, the present invention may be used to remove relatively large tissue masses. In a preferred embodiment, for example, the ribbon 116 has a length of about 1.9 inch, a width of about 0.027 inch and a thickness of about 0.012 inch, which provides a length to width ratio of about 70 to 1 and a length to thickness ratio of over 158 to 1. Of course, the cutting element (ribbon 116) may be configured in a number of different sizes without departing from the invention. When using the device to extract relatively large intact portions of tissue from the breast, the cutting element preferably has a tissue-exposed length of about 1.5 to 5.5 inch. The cutting element is preferably made of stainless steel such as 304 stainless steel, but may, of course, be made of or include any other suitable material such as tungsten, titanium or another stainless steel. The device preferably has only one cutting element mounted to the shaft, or stated

another way, has one cutting surface or cutting edge, although more cutting elements or ribbons may be used with some aspects of the present invention.

[0095] While the foregoing detailed description has described preferred embodiments of the present invention, it is to be understood that the above description is illustrative only and not limiting of the disclosed invention. For example, the shape of the flexible membrane 114 may differ from that described and depicted herein, as may the structure of the integrated cut and collect assembly 108. Those of skill in this art will recognize other alternative embodiments and all such embodiments are deemed to fall within the scope of the present invention. Thus, the present invention should be limited only by the claims as set forth below.

What is claimed is:

1-28. (canceled)

29. A method of removing breast tissue, comprising the steps of:

- providing a tissue cutting device having an elongate cutting element coupled to a shaft, the cutting element being movable between a bowed position and a retracted position, wherein a deployed part of the cutting element lies outside the shaft when in the bowed position, the deployed part of the cutting element having a cutting side which penetrates the tissue as the shaft is rotated;

- introducing the tissue cutting device into a breast;

- coupling a power source to the elongate cutting element;
- moving the elongate cutting element to the bowed position so that the deployed part of the cutting element lies outside the shaft;

- preventing energy from being transmitted from a portion of the deployed part of the cutting element for cutting to the tissue while the elongate cutting element is in the bowed position; and

- rotating the cutting device so that the cutting side of the bowed cutting element penetrates the breast tissue to cut the breast tissue for removal.

30. The method of claim 29, wherein:

- the preventing step is carried out by preventing energy from being transmitted from a radially inner portion of the cutting element to the tissue.

31. The method of claim 29, wherein:

- the preventing step is carried out by partially covering the deployed part of the cutting element.

32. The method of claim 31, wherein:

- the preventing step is carried out by partially covering the deployed part of the cutting element with insulation which prevents transmission of energy to the tissue.

33. The method of claim 29, wherein:

- the preventing step is carried out by covering the deployed part of the cutting element with an element which is also movable between bowed and retracted positions.

34. The method of claim 33, wherein:

- the preventing step is carried out with the element positioned adjacent a radially inner side of the cutting element.



**35.** The method of claim 33, wherein:

the preventing step is carried out with a tissue collection element preventing contact between the tissue and the portion of the cutting element; and

the rotating step is carried out to sever tissue which is collected by the tissue collection element.

**36.** The method of claim 29, wherein:

the preventing step is carried out with the portion of the cutting element not transmitting energy being primarily on a trailing side of the cutting element.

**37.** A device for removing tissue, comprising:

a shaft;

a cutting element coupled to the shaft, the cutting element being movable between a bowed position and a retracted position, wherein a deployed part of the cutting element lies outside the shaft when in the bowed position, the deployed part of the cutting element having a cutting side which penetrates the tissue as the shaft is rotated, the cutting element having means for preventing energy for cutting tissue from being transmitted from a portion of the deployed part of the bowed cutting element to the tissue.

**38.** The device of claim 37, wherein:

the preventing means prevents energy from being transmitted from a radially inner portion of the cutting element to the tissue.

**39.** The device of claim 37, wherein:

the preventing means partially covers the deployed part of the cutting element.

**40.** The device of claim 37, wherein:

the preventing means includes insulation which partially covers the deployed part of the cutting element.

**41.** The device of claim 37, wherein:

the preventing means covers the deployed part of the cutting element with an element which is also movable between bowed and retracted positions.

**42.** The device of claim 37, wherein:

the preventing means includes an element positioned adjacent a radially inner side of the cutting element.

**43.** The device of claim 37, wherein:

the preventing means includes a tissue collection element which prevents contact between the tissue being cut and the portion of the cutting element, the tissue collection element collecting the tissue being cut by the cutting element.

**44.** The device of claim 37, wherein:

the preventing step means prevents transmission of energy to the tissue primarily from a trailing side of the cutting element which is opposite the cutting side.

**45.** A device for removing breast tissue, comprising:

a shaft;

a cutting element mounted to the shaft, the cutting element being movable between a bowed position and a straightened position, the cutting element bowing outward away from the shaft when in the bowed position, the cutting element having an elongate cutting side which cuts tissue when the shaft is rotated, the cutting

element having a length which is at least 25 times larger than a width of the cutting element.

**46.** The device of claim 45, wherein:

the cutting element has an exposed surface area for transmitting energy to the tissue being cut, the exposed surface area including a radially inner part and a radially outer part, the radially outer part being larger than the radially inner part.

**47.** The device of claim 45, wherein:

only one cutting element is mounted to the shaft.

**48.** The device of claim 45, wherein:

the cutting element has a rectangular cross-sectional shape.

**49.** The device of claim 45, further comprising:

a tissue collection element coupled to at least one of the cutting element and the shaft, the tissue collection element collecting tissue which is severed by the cutting element.

**50.** The device of claim 45, wherein:

the length of the cutting element is at least 40 times larger than the width of the cutting element.

**51.** The device of claim 45, wherein:

the length of the cutting element is at least 100 times larger than the width of the cutting element.

**52.** The device of claim 45, wherein:

the cutting element has an effective width that is less than the width of the cutting element, the effective width being a width which is exposed for contact with the tissue being cut to transmit cutting energy to the tissue.

**53-55.** (canceled)

**56.** A method of cutting breast tissue for removal, comprising the steps of:

providing a tissue cutting device having an elongate cutting element, the cutting element being movable between a bowed position and a retracted position, the cutting element having a radially outer side and a radially inner side;

introducing the tissue cutting device into a breast;

moving the elongate cutting element to the bowed position;

coupling a power source to the elongate cutting element; and

rotating the cutting element after the moving step so that the cutting element cuts the breast tissue, wherein the radially outer side has a larger surface area for transmitting energy to cut the tissue than the radially inner side.

**57.** The method of claim 56, wherein:

the rotating step is carried out with the radially outer side having an exposed part for transmitting energy to the tissue which is at least 20% larger than an exposed part of the radially inner side for transmitting energy to the tissue.

**58.** The method of claim 56, wherein:

the rotating step is carried out with the radially outer side having an exposed part for transmitting energy to the

tissue which is at least 35% larger than an exposed part of the radially inner side for transmitting energy to the tissue.

**59.** The method of claim 56, wherein:

the rotating step is carried out while partially covering at least part of the radially inner side of the cutting element.

**60.** The method of claim 56, wherein:

the rotating step is carried out with a cover positioned adjacent the cutting element, the cover also being movable between bowed and retracted positions.

**61.** The method of claim 60, wherein:

the preventing step is carried out with the cover positioned adjacent a radially inner side of the cutting element.

**62.** The method of claim 56, wherein:

the preventing step is carried out with the portion of the cutting element not transmitting energy to the tissue being primarily on a trailing side of the cutting element.

**63.** The method of claim 56, wherein:

the preventing step is carried out with a tissue collection element preventing contact between the tissue and the portion of the cutting element; and

the rotating step is carried out to sever tissue which is collected by the tissue collection element.

**64.** The method of claim 56, wherein:

the preventing step is carried out by insulating part of the deployed part of the cutting element to prevent transmission of energy to the tissue.

**65.** A device for cutting breast tissue for removal, comprising:

a shaft; and

an elongate cutting element mounted to the shaft, the cutting element being movable between a bowed position and a retracted position, the cutting element having a radially outer side and a radially inner side, wherein the radially outer side has a larger surface area for transmitting energy to cut the tissue than the radially inner side.

**66.** The device of claim 65, wherein:

the radially outer side has an exposed part for transmitting energy to the tissue which is at least 20% larger than an exposed part of radially inner side for transmitting energy to the tissue.

**67.** The device of claim 65, wherein:

the radially outer side has an exposed part for transmitting energy to the tissue which is at least 35% larger than an exposed part of radially inner side for transmitting energy to the tissue.

**68.** The device of claim 65, wherein:

the radially inner side of the cutting element is partially covered.

**69.** The device of claim 65, wherein:

the radially inner side is covered by a cover positioned adjacent the cutting element, the cover also being movable between bowed and retracted positions.

**70.** The device of claim 65, wherein:

the partially covered portion of the cutting element is on a trailing side of the cutting element.

**71.** The device of claim 65, further comprising:

a tissue collection element for collecting tissue severed by the cutting element.

**72.** The device of claim 65, wherein:

the cutting element has a deployed part lying outside the shaft in the bowed position, wherein at least part of the cutting element is covered with insulation.

**73.** A device for cutting and collecting a specimen from a mass of tissue, comprising:

an integrated cut and collect assembly, the integrated cut and collect assembly including a cutting portion and a collection portion that includes a flexible membrane, the collection portion being attached to the cutting portion, the cutting portion being configured to cut the specimen from the mass of tissue and the collection portion being configured to collect the cut specimen and to isolate the cut specimen within the membrane.

**74.** A method of cutting and isolating a specimen from a mass of tissue, comprising the steps of:

inserting an instrument that includes an integrated cut and collect assembly into the mass of tissue, the integrated cut and collect assembly including a cutting portion and a collection portion that includes a thin flexible membrane, the collection portion being attached to the cutting portion, the cutting portion being configured to cut the specimen from the mass of tissue and the collection portion being configured to collect the cut specimen from the mass of tissue and to isolate the cut specimen from the mass of tissue within the membrane,

isolating the specimen from surrounding tissue by cutting the specimen from the mass of tissue with the cutting portion and collecting the cut specimen within the flexible membrane of the collecting portion.

**75.** A device for cutting and collecting a specimen from a mass of tissue, comprising:

a shaft defining a proximal and a distal end;

a work assembly near the distal end of the shaft, the work assembly being configured to cut the specimen from the mass of soft tissue and to isolate the cut specimen from surrounding tissue;

a single actuator near the proximal end of the shaft, the single actuator being mechanically coupled to the work assembly such that rotation of the device and operation of the single actuator is effective to cut, collect and isolate the specimen from the mass of tissue as the device is rotated.

**76.** A method of collecting a tissue specimen from a mass of tissue, comprising the steps of:

inserting a surgical instrument into the mass of tissue to a target location within the mass of tissue, the instrument including a shaft and a work assembly near a distal end of the shaft, the work assembly being configured to controllably cut the specimen from the mass of soft tissue and to isolate the cut specimen from the mass of tissue within a tissue isolator;

controlling the work assembly of the surgical instrument to cut and isolate the specimen, and

retracting the instrument from the mass of tissue while the specimen is isolated within the tissue isolator and at least partially trails the distal end of the shaft.

77. A surgical instrument for retrieving a tissue specimen from a mass of tissue, comprising:

a shaft defining a proximal and a distal end, and

a work assembly coupled to the shaft near the distal end thereof, the work assembly including:

a tissue cutting portion configured to cut the tissue specimen from the mass of tissue;

a tissue collection portion that includes a membrane, the membrane being configured to encapsulate and isolate the cut specimen from the mass of tissue and being adapted to stretch to enable the encapsulated specimen to at least partially trail the distal end of the shaft as the surgical instrument is retracted from the mass of tissue.

\* \* \* \* \*