



- (51) International Patent Classification:
B01J 38/02 (2006.01) **B01J 19/24** (2006.01)
B01J 38/04 (2006.01)
- (21) International Application Number:
PCT/US2016/037558
- (22) International Filing Date:
15 June 2016 (15.06.2016)
- (25) Filing Language: English
- (26) Publication Language: English
- (30) Priority Data:
62/184,416 25 June 2015 (25.06.2015) US
- (71) Applicant: **UOP LLC** [US/US]; 25 East Algonquin Road, P. O. Box 5017, Des Plaines, Illinois 60017-5017 (US).
- (72) Inventors: **COX, Pelin**; Uop LLC, 25 East Algonquin Road, P.O. Box 5017, Des Plaines, Illinois 60017-5017 (US). **SCHLUETER, William D.**; Uop LLC, 25 East Algonquin Road, P.O. Box 5017, Des Plaines, Illinois 60017-5017 (US). **YANEZ, William**; Uop LLC, 25 East Algon-

quin Road, P.O. Box 5017, Des Plaines, Illinois 60017-5017 (US). **GROTT, Jeffrey**; Uop LLC, 25 East Algonquin Road, P.O. Box 5017, Des Plaines, Illinois 60017-5017 (US).

(74) Agent: **ROMANO, Ashley E.**; Uop LLC, 25 East Algonquin Road, P. O. Box 5017, Des Plaines, Illinois 60017-5017 (US).

(81) Designated States (unless otherwise indicated, for every kind of national protection available): AE, AG, AL, AM, AO, AT, AU, AZ, BA, BB, BG, BH, BN, BR, BW, BY, BZ, CA, CH, CL, CN, CO, CR, CU, CZ, DE, DK, DM, DO, DZ, EC, EE, EG, ES, FI, GB, GD, GE, GH, GM, GT, HN, HR, HU, ID, IL, IN, IR, IS, JP, KE, KG, KN, KP, KR, KZ, LA, LC, LK, LR, LS, LU, LY, MA, MD, ME, MG, MK, MN, MW, MX, MY, MZ, NA, NG, NI, NO, NZ, OM, PA, PE, PG, PH, PL, PT, QA, RO, RS, RU, RW, SA, SC, SD, SE, SG, SK, SL, SM, ST, SV, SY, TH, TJ, TM, TN, TR, TT, TZ, UA, UG, US, UZ, VC, VN, ZA, ZM, ZW.

(84) Designated States (unless otherwise indicated, for every kind of regional protection available): ARIPO (BW, GH,

[Continued on next page]

(54) Title: METHODS FOR CATALYST STRIPPING

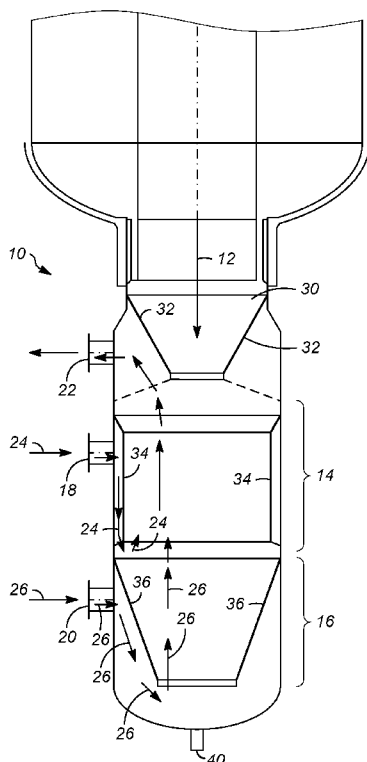

FIG. 1

(57) Abstract: A process is disclosed for an improved catalyst stripping process. The stripping vessel is divided into two zones. The first zone is a stripping zone where a substantial portion of the volatile hydrocarbons is removed at higher severity conditions. After the catalyst is stripped, the stripped catalyst moves to the lower cooling zone to be cooled at lower severity conditions. The flow rates, temperatures, pressures and the stripping and cooling zones are designed to ensure there is minimal volatile hydrocarbons on the catalyst by the time it leaves the stripping vessel. This design enables efficient stripping of volatile hydrocarbons at high severity conditions and eliminates these components from being stripped off elsewhere in the unit causing process and equipment issues.

WO 2016/209680 A1



GM, KE, LR, LS, MW, MZ, NA, RW, SD, SL, ST, SZ, TZ, UG, ZM, ZW), Eurasian (AM, AZ, BY, KG, KZ, RU, TJ, TM), European (AL, AT, BE, BG, CH, CY, CZ, DE, DK, EE, ES, FI, FR, GB, GR, HR, HU, IE, IS, IT, LT, LU, LV, MC, MK, MT, NL, NO, PL, PT, RO, RS, SE, SI, SK, SM, TR), OAPI (BF, BJ, CF, CG, CI, CM, GA, GN, GQ, GW, KM, ML, MR, NE, SN, TD, TG).

Published:

- *with international search report (Art. 21(3))*
- *before the expiration of the time limit for amending the claims and to be republished in the event of receipt of amendments (Rule 48.2(h))*

METHODS FOR CATALYST STRIPPING

STATEMENT OF PRIORITY

5 [0001] This application claims priority to U.S. Provisional Application No. 62/184416 which was filed June 25, 2015, the contents of which are hereby incorporated by reference in its entirety.

FIELD

[0002] The present subject matter relates generally to methods for catalyst stripping. More specifically, the present subject matter relates to methods for stripping and cooling a catalyst for reuse in the hydrocarbon conversion process.

10

BACKGROUND

[0003] Hydrocarbons, and in particular petroleum, are produced from the ground as a mixture. This mixture is converted to useful products through separation and processing of the streams in reactors. The conversion of the hydrocarbon streams to useful products is often through a catalytic process in a reactor. The catalysts can be solid or liquid, and can
15 comprise catalytic materials. In bi-functional catalysis, catalytic materials of acid such as zeolite and metals such as those in transition and main groups are combined to form a composite to facilitate the conversion process such as the one described in this subject application.

[0004] During the processing of the hydrocarbons, the catalysts deactivate over time.
20 One primary cause of deactivation is the generation and buildup of non-volatile coke on the catalyst. The accumulation of non-volatile coke covers or blocks access to catalytic sites on the catalyst therefore, the spent catalyst is regenerated and returned to the reactor for further use. The regeneration of the catalyst is normally performed through the removal of the coke, where the coke is combusted at a high-temperature with a gas having
25 oxygen. During the processing of the hydrocarbons, in addition to non-volatile coke lay down on the catalyst volatile hydrocarbons are also absorbed onto the catalyst. Prior to regeneration it is desirable to remove or strip the volatile hydrocarbons from the spent catalyst. Volatile hydrocarbons if not stripped properly will come off during high temperature regeneration or reactor conditions and foul the associated equipments such as

reactor and regenerator internals, compressors, heat exchanging equipment, pipes and other vessels causing significant cleaning cost and reduction in plant operation time due to associated shutdowns. Preferred level of stripping necessitates high severity temperatures to desorb a substantial amount of volatilizable carbonaceous materials.

5 Normally stripping is carried out in a so-called stripper, which is limited to low severity temperatures enabling the catalyst to be lifted or transported to the regenerator. Low temperature operation invariably causes insufficient stripping of the volatile hydrocarbon species. Normally, this so-called stripper is an elongated vessel provided with side-to-side interior baffle. The spent catalyst is cascaded downwardly over the stripper baffle while
10 the gas stream flowing counter currently to the descending catalyst.

SUMMARY

[0005] The present subject matter provides an improved catalyst stripping process. The stripping zone is divided into two zones, a stripping zone and a cooling zone. In the stripping zone, a substantial portion of the residual volatile hydrocarbons is removed at
15 higher severity conditions. After the catalyst is stripped, the stripped catalyst moves to a cooling zone to be cooled at lower severity conditions. The flow rates, temperatures, pressures and the stripping zone are designed to ensure there is minimal volatile hydrocarbon left on the catalyst by the time it leaves the stripping zone. This design eliminates high levels of residual volatile hydrocarbons in both the regeneration zone and
20 the reactors.

[0006] In the stripping zone, a first gas is passed into the stripping zone and flows over the catalyst to remove a substantial portion of residual volatile hydrocarbons. The first gas is heated to a temperature between 200°C and 650°C before passing into the stripping zone. The first gas is distributed around the stripping zone and flows through the catalyst
25 countercurrently passing up through the first stripping zone. The second gas is at a temperature between 38°C and 300°C before passing into the cooling zone. The second gas flows up through the cooling zone and flows counter currently against the catalyst before exiting the cooling zone. The stripped and cooled catalyst is withdrawn through the catalyst outlet at the bottom of the cooling zone.

[0007] Additional objects, advantages and novel features of the examples will be set forth in part in the description which follows, and in part will become apparent to those skilled in the art upon examination of the following description and the accompanying drawings or may be learned by production or operation of the examples. The objects and advantages of the concepts may be realized and attained by means of the methodologies, instrumentalities and combinations particularly pointed out in the appended claims.

DEFINITIONS

[0008] As used herein, the term “dehydrocyclodimerization” is also referred to as aromatization of light paraffins. Within the subject disclosure, dehydrocyclodimerization and aromatization of light hydrocarbons are used interchangeably.

[0009] As used herein, the term “stream”, “feed”, “product”, “part” or “portion” can include various hydrocarbon molecules, such as straight-chain, branched, or cyclic alkanes, alkenes, alkadienes, and alkynes, and optionally other substances, such as gases, e.g., hydrogen, or impurities, such as heavy metals, and sulfur and nitrogen compounds. The stream can also include aromatic and non-aromatic hydrocarbons. Moreover, the hydrocarbon molecules may be abbreviated C₁, C₂, C₃, C_n where “n” represents the number of carbon atoms in the one or more hydrocarbon molecules or the abbreviation may be used as an adjective for, e.g., non-aromatics or compounds. Similarly, aromatic compounds may be abbreviated A₆, A₇, A₈, A_n where “n” represents the number of carbon atoms in the one or more aromatic molecules. Furthermore, a superscript “+” or “-” may be used with an abbreviated one or more hydrocarbons notation, e.g., C₃₊ or C₃₋, which is inclusive of the abbreviated one or more hydrocarbons. As an example, the abbreviation “C₃₊” means one or more hydrocarbon molecules of three or more carbon atoms.

[0010] As used herein, the term “zone” can refer to an area including one or more equipment items and/or one or more sub-zones. Equipment items can include, but are not limited to, one or more reactors or reactor vessels, separation vessels, distillation towers, heaters, exchangers, pipes, pumps, compressors, and controllers. Additionally, an equipment item, such as a reactor, dryer, or vessel, can further include one or more zones or sub-zones.

[0011] As used herein, the term "active metal" can include metals selected from IUPAC Groups that include 6, 7, 8, 9, 10, 13 and mixtures of thereof. The IUPAC Group 6 through 10 includes without limitation chromium, molybdenum, tungsten, rhenium, platinum, palladium, rhodium, iridium, ruthenium, osmium, zinc, copper, and silver. The IUPAC Group 13 includes without limitation gallium and indium.

[0012] As used herein, the term "modifier metal" can include metals selected from IUPAC Groups 11-17. The IUPAC Group 11 through 17 includes without limitation sulfur, gold, tin, germanium, and lead.

[0013] As used herein, the term "thermal mass ratio" (TMR) is defined as the ratio of the gas flow rate to the catalyst circulation rate.

[0014] As used herein, the term "volatile hydrocarbons" can include hydrocarbons that are aromatic or non-aromatic, straight chain, branched or cyclic alkanes, alkenes and alkadienes.

BRIEF DESCRIPTION OF THE DRAWINGS

[0015] The drawing figures depict one or more implementations in accord with the present concepts, by way of example only, not by way of limitations. In the figures, like reference numerals refer to the same or similar elements.

[0016] FIG. 1 is a cross-sectional view of a vessel embodying the present invention.

[0017] FIG. 2 is another cross-sectional view of a vessel embodying the present invention.

DETAILED DESCRIPTION

[0018] The following detailed description is merely exemplary in nature and is not intended to limit the application and uses of the embodiment described. Furthermore, there is no intention to be bound by any theory presented in the preceding background or the following detailed description.

[0019] FIG. 1 illustrates a diagram of various embodiments of the processes described herein. Those skilled in the art will recognize that this process flow diagram has been simplified by the elimination of many pieces of process equipment including for example,

heat exchangers, process control systems, pumps, fractionation column overhead, reboiler systems and reactor internals, etc. which are not necessary to an understanding of the process. It may also be readily discerned that the process flow presented in the drawing may be modified in many aspects without departing from the basic overall concept. For example, the depiction of required heat exchangers in the drawing have been held to a minimum for purposes of simplicity. Those skilled in the art will recognize that the choice of heat exchange methods employed to obtain the necessary heating and cooling at various points within the process is subject to a large amount of variation as to how it is performed. In a process as complex as this, there exists many possibilities for indirect heat exchange between different process streams. Depending on the specific location and circumstance of the installation of the subject process, it may also be desired to employ heat exchange against steam, hot oil, or process streams from other processing units not shown on the drawing.

[0020] With reference to FIG. 1, a system and process in accordance with various embodiments includes a vessel **10**. A stream of spent catalyst particles **12** is continuously introduced to the vessel **10**. Although the term continuous is applied to this process herein, the process may include a continuous, semi-continuous, or batch process where small amounts of catalyst are withdrawn from the reactor and passed to the stripping zone on a relatively continuous basis. The catalyst particles **12** flow downward through the vessel **10**. The catalyst particles **12** may exit from a reactor. The reactor may be a dehydrogenation reactor, a reforming reactor, a dehydrocyclodimerization reactor, or any other reactor used in the conversion of hydrocarbons. The vessel **10** is divided into an upper stripping zone **14** and a lower cooling zone **16**. In the example shown in FIG. 1, the upper stripping zone **14** is in communication with the lower cooling zone **16**. However, it is also contemplated that there may be an intermediate section. The intermediate section may allow for the separation of the upper stripping zone **14** and the lower cooling zone **16** by interposing the intermediate section in between the upper stripping zone **14** and the lower cooling zone **16**. As catalyst particles **12** flow down through the opening **30**, the catalyst particles **12** are directed into the upper stripping zone **14** via the baffle **32**. The baffle **32** may be conical in shape. The opening of the baffle **32** allows for the catalyst particles **12** to enter the upper stripping zone **14**. The top portion of the baffle **32** is connected to the inner wall of the vessel **10** whereas the bottom portion of the baffle **32** is

truncated and provides an opening for the catalyst particles **12** to pass through. The bottom portion of the baffle **32** is lower than the outlet **22** so that the catalyst particles **12** entering the upper stripping zone **14** do not interfere with the gas exiting the outlet **22**.

[0021] In the upper stripping zone **14**, a first gas **24** enters through the upper stripping zone inlet **18** and contacts the catalyst particles **12** to reduce the residual volatile hydrocarbons on the catalyst particles **12**. After the first gas **24** enters the vessel **10** through the upper stripping zone inlet **18**, the first gas is directed downwardly by prevention of upward flow by a cylindrical baffle **34** and then the first gas enters the upper stripping zone **14** and rises up the upper stripping zone **14**. In the example illustrated in FIG. 1, the baffle **34** is cylindrical. The top portion of the baffle **34** is connected to the inside of the vessel **10**. The baffle **34** curves inward so that the gas entering the inlet **18** has space to enter the upper stripping zone **14**. The catalyst particles **12** flow down through the upper stripping zone **14** at a rate to provide sufficient time for the catalyst particles **12** to be thoroughly stripped. The catalyst particles **12** contact the first gas counter-currently. However, it is also contemplated that the catalyst particles **12** may contact the first gas co-currently as well. The catalyst will have an average residence time in the upper stripping zone between 0.1 hours and 3 hours, with a preferred time between 1 hour and 2 hours. In an aspect, at least 25 wt% of the totally residual volatile hydrocarbons on the catalyst is removed in the first stripping zone.

[0022] The first gas may be cycled through a upper stripping zone **14** using a first blower for circulation of the gas. The first gas may also be cycled using a compressor. The first gas may include hydrogen. However, it is also contemplated that the gas may include H₂, N₂, Ar, He, C₁, C₂, C₃, CO₂, or mixtures thereof. The first gas is heated to a stripping temperature before passing to the upper stripping zone as the first gas stream through inlet **24**. The first gas exits the stripping zone **14** through the outlet **22** which may be higher than the inlet **18**. The upper stripping zone temperature is between 200°C and 650°C, with a preferable temperature between 300°C and 500°C. The pressure for the upper stripping zone is between 2 psig (13.7 kPa (g)) to 75 psig (517 kPa (g)) and thermal mass ratio of the first gas stream is between 0.8 and 5.

[0023] In the example shown in FIG. 1, the first gas stream **24** flows counter-currently to the catalyst to contact the catalyst particles **12**. However, it is also contemplated that the

first gas stream **24** may flow co-currently to the catalyst particles **12**. The catalyst particles **12** flow downward from the upper stripping zone **14** using gravity. Therefore in the example where the catalyst particles **12** and the first gas stream **24** flow counter-currently, the first gas **24** must enter the first gas stream inlet **18** and exit the first gas stream outlet **22**. However, in the example where the catalyst particles **12** and the first gas stream **24** flow co-currently, the first gas stream **24** may enter at opening **22** and exit at opening **18**.

[0024] FIG. 1 illustrates no intermediate zone. Therefore, the upper stripping zone **14** may be in direct contact with the lower cooling zone **16**. Therefore, catalyst particles **12** may flow directly from the upper stripping zone **14** to the lower cooling zone **16**.

[0025] The catalyst is further processed and flows from the upper stripping zone **14** to the lower cooling zone **16**, where the catalyst is contacted with a second gas stream **26** for cooling of the catalyst particles **12**. The second gas **26** enters through the lower cooling zone inlet **20** and is cycled through the lower cooling zone **16** using a second blower for circulation of the gas. The second gas **26** may also be cycled using a compressor. The second gas is made up of hydrogen. However it is also contemplated that the second gas may include H₂, N₂, Ar, He, C₁, C₂, C₃, C₄, CO₂, air or mixtures thereof. The second gas **26** may be heated or cooled before passing to the lower cooling zone **16** as the second gas stream **26**. The second gas **26** exits the vessel **10** through the outlet **22**. In the embodiment illustrated in FIG. 1, the first gas stream **24** and the second gas stream **26** both exit the outlet **22**.

[0026] As illustrated in FIG. 1, as catalyst particles **12** flow down through the lower cooling zone **16** the catalyst particles **12** are directed into the lower cooling zone **16** via the baffle **36**. As catalyst particles **12** flow down into the lower cooling zone **16**, the catalyst particles **12** are directed into the lower cooling zone **16** via the baffle **36**. The baffle **36** may be conical in shape. The opening of the baffle **36** allows for the catalyst particles **12** to enter the lower cooling zone **16**. The top portion of the baffle **36** is connected to the inner wall of the vessel **10** whereas the bottom portion of the baffle **36** is truncated and provides an opening for the catalyst particles **12** to pass through. In the lower cooling zone **16**, a second gas **26** enters through the lower cooling zone inlet **20** and contacts the catalyst particles **12** to cool the catalyst particles **12**. After the second gas **26** enters the vessel **10** through the lower cooling zone inlet **20** the second gas **26** is directed downward

via the baffle **36** and then the second gas **26** enters the lower cooling zone **16** and rises up through the lower cooling zone **16**. The catalyst particles **12** flow down through the lower cooling zone **16** to provide sufficient time for the catalyst particles **12** to be cooled. The catalyst particles **12** contact the second gas **26** counter-currently. However, it is also
5 contemplated that the catalyst particles **12** may contact the second gas **26** co-currently as well. The second cooling temperature is between 30°C and 300°C, with a preferable temperature between 50°C and 200°C. The pressure for the lower cooling zone is between 2 psig (13.7 kPa (g)) to 50 psig (345 kPa (g)) and thermal mass ratio of the second gas stream is between 0.8 and 5. Depending on the temperature of the gas and the source the
10 gas comes from, the gas may be have to be heated or cooled to be brought to the preferred temperature.

[0027] The lower cooling zone **16** is operated and sized to allow for the catalyst to reside in the lower zone between 0.1 hours and 3 hours, with a preferred average residence time between 1 hour and 2 hours.

15 **[0028]** Once the catalyst particles **12** have been stripped in the upper stripping zone **14** and cooled in the lower cooling zone **16**, the catalyst particles **12** exit the vessel **10** via the opening **40**. Once the catalyst particles **12** leave the vessel **10**, they have been sufficiently stripped and cooled so they may be suitable for lifting. The upper stripping zone **14** minimizes the volatile hydrocarbon carryover to the regenerator, and the lower cooling
20 zone **16** ensures that the catalyst is suitable for lifting to the regenerator structure.

[0029] An advantage of the catalyst stripping process is that stripping and cooling of the catalyst in two or more separate zones can effectively remove the residual hydrocarbons therefore preventing downstream equipment issues, while keeping the stripping zone size minimal. The present subject matter further includes a lower cooling zone **16** where a
25 separate gas is used to cool the catalyst particles **12**.

[0030] Another embodiment is illustrated in FIG. 2. In this embodiment, the upper stripping zone **14** and the lower cooling zone **16** each include distinct inlets and outlets. Therefore, in this embodiment, the first gas **24** does not contact the second gas **26**. Here, the first gas **24** that enters the upper stripping zone via inlet **18** is directed by the baffle **34**
30 and enters the upper stripping zone **14** and then exits via outlet **22**. As illustrated in FIG. 2, the second gas **26** enters the lower cooling zone **16** via inlet **20** and is directed to the lower

cooling zone via the baffle 36. The second gas 26 then contacts the catalyst particles 12 in the lower cooling zone 16 and then is directed to the lower cooling zone outlet 23 via the baffle 38 and then exits the lower cooling zone 16 via outlet 23.

[0031] As illustrated in FIG. 2, the lower cooling zone 16 has an additional baffle 38. As
5 catalyst particles 12 flow down into the lower cooling zone 16, the catalyst particles 12 are directed into the lower cooling zone 16 via the baffle 38. Also, as explained above, the baffle 38 directs the first gas 24 to the outlet 23. The baffle 38 may be conical in shape. The opening of the baffle 38 allows for the catalyst particles 12 to enter the lower cooling zone 16. The top portion of the baffle 38 is connected to the inner wall of the vessel 10
10 whereas the bottom portion of the baffle 38 is truncated and provides an opening for the catalyst particles 12 to pass through. Once the catalyst particles 12 exit at the bottom of the baffle 38, the catalyst particles are further directed downward through the lower cooling zone 16 via baffle 36. Once the catalyst particles 12 have been stripped in the upper stripping zone 14 and cooled in the lower cooling zone 16, the catalyst particles 12 exit the
15 vessel 10 via the opening 40. Once the catalyst particles 12 leave the vessel 10, they have been sufficiently stripped and cooled so they may be suitable for lifting. The upper stripping zone 14 minimizes the hydrocarbon carryover to the regenerator, and the lower cooling zone 16 ensures that the catalyst is suitable for lifting to the regenerator structure.

[0032] In a further embodiment, the upper stripping zone and the lower cooling zone
20 may be housed in separate vessels. In this embodiment, the first gas would only enter the upper stripping zone in a first vessel, and the second gas would only enter the lower cooling zone in the second vessel. Therefore the catalyst particles would be stripped in the first vessel and cooled in the second vessel.

[0033] Another advantage of this method of catalyst stripping and cooling process is
25 that the multiple zones may have temperature control of each inlet gas entering the individual zones. The first gas stream and the second gas stream may include a common gas loop. For example, if the first gas stream and the second gas stream include a common gas loop the first gas and second gas streams may include the same temperature control, the same gas composition control, the same driers, or a mixture thereof. However, it is also
30 contemplated that the first gas stream and the second gas stream may have independent

gas loops. For example, in this configuration the composition, temperature, and the drier system of the first gas stream and the second gas stream may be independent.

[0034] Any suitable catalyst may be utilized. The catalyst may be amorphous silica-alumina or such as at least one molecular sieve including any suitable material, e.g., alumino-silicate. The catalyst can include an effective amount of the molecular sieve, which can be a zeolite with at least one pore having a 10 or higher member ring structure and can have one or higher dimension. Typically, the zeolite can have a Si/A₁₂ mole ratio of greater than 10:1, preferably 20:1 - 60:1. Preferred molecular sieves can include BEA, MTW, FAU (including zeolite Y and zeolite X), EMT, FAU/EMT intergrowth, MOR, LTL, ITH, ITW, MFI, MSE, MEL, MFI/MEL intergrowth, TUN, IMF, FER, TON, MFS, IWW, EUO, MTT, HEU, CHA, ERI, MWW, AEL, AFO, ATO, and LTA. Preferably, the zeolite can be MFI, MEL, MFI/MEL intergrowth, TUN, IMF, MSE and/or MTW. Suitable zeolite amounts in the catalyst may range from 1 - 100%, and preferably from 10 - 90%, by weight.

[0035] Generally, the catalyst includes at least one metal selected from active metals, and optionally at least one metal selected from modifier metals. The total active metal content on the catalyst by weight is less than 5% by weight. In some embodiments, the preferred total active metal content is less than 3.0%, in yet in another embodiment the preferred total active metal content is less than 1.5%, still in yet in another embodiment the total active metal content on the catalyst by weight is less than 0.5wt%. At least one metal is selected from IUPAC Groups that include 6, 7, 8, 9, 10, and 13. The IUPAC Group 6 through 10 includes without limitation chromium, molybdenum, tungsten, rhenium, platinum, palladium, rhodium, iridium, ruthenium and osmium, zinc, copper, and silver. The IUPAC Group 13 includes without limitation gallium, indium. In addition to at least one active metal, the catalyst may also contain at least one modifier metal selected from IUPAC Groups 11-17. The IUPAC Group 11 through 17 includes without limitation sulfur, gold, tin, germanium, and lead.

EXAMPLES

[0036] The following examples are intended to further illustrate the subject embodiments. These illustrations of different embodiments are not meant to limit the

claims to the particular details of these examples. These examples are based on boiling points of heavy aromatics components.

Table 1

| Formula | Name | BP (°C) | Rings |
|---------------------------------|---------------|---------|-------|
| C ₆ H ₆ | Benzene | 80 | 1 |
| C ₁₀ H ₈ | Naphthalene | 217 | 2 |
| C ₁₄ H ₁₀ | Anthracene | 340 | 3 |
| C ₁₆ H ₁₀ | Pyrene | 404 | 4 |
| C ₂₀ H ₁₂ | Benzopyrene | 495 | 5 |
| C ₂₂ H ₁₂ | Benzoperylene | 497 | 6 |
| C ₂₄ H ₁₂ | Coronene | 526 | 7 |
| C ₂₈ H ₁₄ | Benzocoronene | 605 | 8 |

- 5 [0037] Table 1 demonstrates the benefits of having a stripping zone design and a cooling zone as compared to a single stripping zone design operated at low temperatures. As shown in the Table 1, efficient stripping necessitates high severity temperatures to strip off volatile hydrocarbons which inevitably prevents these components from being stripped off elsewhere in the unit causing process and equipment issues.
- 10 [0038] It should be noted that various changes and modifications to the presently preferred embodiments described herein will be apparent to those skilled in the art. Such changes and modifications may be made without departing from the spirit and scope of the present subject matter and without diminishing its attendant advantages.

SPECIFIC EMBODIMENTS

- 15 [0039] While the following is described in conjunction with specific embodiments, it will be understood that this description is intended to illustrate and not limit the scope of the preceding description and the appended claims.

- [0040] A first embodiment of the invention is a method of stripping and cooling a catalyst comprising feeding a catalyst to a upper stripping zone operating at upper stripping zone conditions; passing a first gas stream comprising gas to the upper stripping zone, thereby generating a stripped catalyst; passing the stripped catalyst to a lower
- 20

cooling zone operating at lower cooling zone conditions that are less severe than the upper stripping zone conditions; and passing a second gas stream comprising gas to a lower cooling zone, thereby generating a stripped and cooled catalyst. An embodiment of the invention is one, any or all of prior embodiments in this paragraph up through the first

5 embodiment in this paragraph, wherein the upper stripping zone conditions include a temperature from 200°C (392°F) to 650°C (1202°F). An embodiment of the invention is one, any or all of prior embodiments in this paragraph up through the first embodiment in this paragraph, wherein the pressure for the upper stripping zone is between 2 psig (13.7 kPa (g)) to 75 psig (517 kPa (g)) and thermal mass ratio of the first gas stream is between

10 0.8 and 5. An embodiment of the invention is one, any or all of prior embodiments in this paragraph up through the first embodiment in this paragraph, wherein at least 25 wt% of the residual volatile hydrocarbons on the catalyst is removed in the upper stripping zone. An embodiment of the invention is one, any or all of prior embodiments in this paragraph up through the first embodiment in this paragraph, wherein the first gas stream flows

15 counter-currently to the catalyst. An embodiment of the invention is one, any or all of prior embodiments in this paragraph up through the first embodiment in this paragraph, wherein the first gas stream flows co-currently to the catalyst. An embodiment of the invention is one, any or all of prior embodiments in this paragraph up through the first embodiment in this paragraph, wherein the upper stripping zone residence times are

20 between 0.1 hours and 3 hours. An embodiment of the invention is one, any or all of prior embodiments in this paragraph up through the first embodiment in this paragraph, wherein the lower cooling zone conditions includes a temperature from 38°C (100°F) to 300°C (572°F). An embodiment of the invention is one, any or all of prior embodiments in this paragraph up through the first embodiment in this paragraph, wherein the pressure for the

25 lower stripping zone is between 2 psig (13.7 kPa (g)) to 50 psig(345 kPa (g)) and thermal mass ratio of the first gas stream is between 0.8 and 5. An embodiment of the invention is one, any or all of prior embodiments in this paragraph up through the first embodiment in this paragraph, wherein the second gas stream flows counter-currently to the catalyst. An embodiment of the invention is one, any or all of prior embodiments in this paragraph up

30 through the first embodiment in this paragraph, wherein the second gas stream flows co-currently with the catalyst. An embodiment of the invention is one, any or all of prior embodiments in this paragraph up through the first embodiment in this paragraph, wherein

the lower cooling zone residence times are between 0.1 hours and 3 hours. An

embodiment of the invention is one, any or all of prior embodiments in this paragraph up through the first embodiment in this paragraph, wherein the first gas stream contacts the second gas stream in the upper stripping zone before exiting the upper stripping zone. An

5 embodiment of the invention is one, any or all of prior embodiments in this paragraph up through the first embodiment in this paragraph, wherein the first gas stream exits the upper stripping zone from a first distinct outlet, and the second gas stream exits the lower cooling zone from a second distinct outlet. An embodiment of the invention is one, any or all of prior embodiments in this paragraph up through the first embodiment in this
10 paragraph, wherein the upper stripping zone and the lower cooling zone are housed in separate vessels.

[0041] A second embodiment of the invention is an apparatus for stripping and cooling a catalyst comprising a vessel having an upper portion wherein the upper portion includes an opening, a first baffle and an outlet, an upper stripping zone having a first inlet and a

15 second baffle and a lower cooling zone having a second inlet, a third baffle, and a bottom opening, wherein the upper stripping zone is in fluid communication with the lower cooling zone. An embodiment of the invention is one, any or all of prior embodiments in this paragraph up through the first embodiment in this paragraph, wherein the first baffle is a conical baffle having a top portion that is connected to the inside of the vessel and a
20 bottom portion that is truncated and provides an opening. An embodiment of the invention is one, any or all of prior embodiments in this paragraph up through the first embodiment in this paragraph, wherein the second baffle is a cylindrical baffle having a top portion which extends inward from the vessel and curves downward. An embodiment of the invention is one, any or all of prior embodiments in this paragraph up through the first
25 embodiment in this paragraph, wherein the third baffle is a conical baffle having a top portion that is connected to the inside of the vessel and a bottom portion that is truncated and provides an opening. An embodiment of the invention is one, any or all of prior embodiments in this paragraph up through the first embodiment in this paragraph, further comprising a second outlet in the lower cooling zone.

30 **[0042]** A third embodiment of the invention is an apparatus for stripping and cooling a catalyst comprising a vessel having a top opening having a first baffle and a first outlet, an upper stripping zone having a first inlet and a second baffle and a lower cooling zone

having a second outlet, a second inlet, a third baffle, and a bottom opening, wherein the upper stripping zone is in fluid communication with the lower cooling zone. An embodiment of the invention is one, any or all of prior embodiments in this paragraph up through the second embodiment in this paragraph, wherein the first baffle is a conical baffle having a top portion that is connected to the inside of the vessel and a bottom portion that is truncated and provides an opening. An embodiment of the invention is one, any or all of prior embodiments in this paragraph up through the second embodiment in this paragraph, wherein the second baffle is a cylindrical baffle having a top portion which extends inward from the vessel and curves downward. An embodiment of the invention is one, any or all of prior embodiments in this paragraph up through the second embodiment in this paragraph, wherein the third baffle is a conical baffle having a top portion that is connected to the inside of the vessel and a bottom portion that is truncated and provides an opening.

[0043] A fourth embodiment of the invention is an apparatus for stripping and cooling a catalyst comprising a vessel having a top opening having a first baffle and a first outlet, an upper stripping zone having a first inlet and a second baffle and a lower cooling zone having a second outlet, a third baffle, a second inlet, a fourth baffle, and a bottom opening, wherein the upper stripping zone is in fluid communication with the lower cooling zone. An embodiment of the invention is one, any or all of prior embodiments in this paragraph up through the third embodiment in this paragraph, wherein the first baffle is a conical baffle having a top portion that is connected to the inside of the vessel and a bottom portion that is truncated and provides an opening. An embodiment of the invention is one, any or all of prior embodiments in this paragraph up through the third embodiment in this paragraph, wherein the second baffle is a cylindrical baffle having a top portion which extends inward from the vessel and curves downward. An embodiment of the invention is one, any or all of prior embodiments in this paragraph up through the third embodiment in this paragraph, wherein the third baffle is a conical baffle having a top portion that is connected to the inside of the vessel and a bottom portion that is truncated and provides an opening. An embodiment of the invention is one, any or all of prior embodiments in this paragraph up through the third embodiment in this paragraph, wherein the fourth baffle is a conical baffle having a top portion that is connected to the inside of the vessel and a bottom portion that is truncated and provides an opening.

[0044] A fifth embodiment of the invention is an apparatus for stripping and cooling a catalyst comprising a first vessel having a top opening having a first baffle and a first outlet, a stripping zone having a first inlet and a second baffle; and a second vessel having a cooling zone having a second outlet, a third baffle, a second inlet, a fourth baffle, and a bottom opening. An embodiment of the invention is one, any or all of prior embodiments in this paragraph up through the fourth embodiment in this paragraph, wherein the first vessel is coupled to the second vessel. An embodiment of the invention is one, any or all of prior embodiments in this paragraph up through the fourth embodiment in this paragraph, wherein the first baffle is a conical baffle having a top portion that is connected to the inside of the vessel and a bottom portion that is truncated and provides an opening. An embodiment of the invention is one, any or all of prior embodiments in this paragraph up through the fourth embodiment in this paragraph, wherein the second baffle is a cylindrical baffle having a top portion which extends inward from the vessel and curves downward. An embodiment of the invention is one, any or all of prior embodiments in this paragraph up through the fourth embodiment in this paragraph, wherein the third baffle is a conical baffle having a top portion that is connected to the inside of the vessel and a bottom portion that is truncated and provides an opening. An embodiment of the invention is one, any or all of prior embodiments in this paragraph up through the fourth embodiment in this paragraph, wherein the fourth baffle is a conical baffle having a top portion that is connected to the inside of the vessel and a bottom portion that is truncated and provides an opening.

[0045] Without further elaboration, it is believed that using the preceding description that one skilled in the art can utilize the present invention to its fullest extent and easily ascertain the essential characteristics of this invention, without departing from the spirit and scope thereof, to make various changes and modifications of the invention and to adapt it to various usages and conditions. The preceding preferred specific embodiments are, therefore, to be construed as merely illustrative, and not limiting the remainder of the disclosure in any way whatsoever, and that it is intended to cover various modifications and equivalent arrangements included within the scope of the appended claims.

[0046] In the foregoing, all temperatures are set forth in degrees Celsius and, all parts and percentages are by weight, unless otherwise indicated.

CLAIMS:

1. A method of stripping and cooling a catalyst comprising:
feeding a catalyst to a upper stripping zone operating at upper stripping zone conditions;
5 passing a first gas stream comprising gas to the upper stripping zone, thereby generating a stripped catalyst;
passing the stripped catalyst to a lower cooling zone operating at lower cooling zone conditions that are less severe than the upper stripping zone conditions; and
passing a second gas stream comprising gas to a lower cooling zone, thereby generating a
10 stripped and cooled catalyst.
2. The method of claim 1, wherein the upper stripping zone conditions include a temperature from 200°C (392°F) to 650°C (1202°F).
- 15 3. The method of claim 1, wherein the pressure for the upper stripping zone is between 2 psig (13.7 kPa (g)) to 75 psig (517 kPa (g)) and thermal mass ratio of the first gas stream is between 0.8 and 5.
4. The method of claim 1, wherein at least 25 wt% of the residual volatile
20 hydrocarbons on the catalyst is removed in the upper stripping zone.
5. The method of claim 1, wherein the first gas stream flows counter-currently to the catalyst.
- 25 6. An apparatus for stripping and cooling a catalyst comprising:
a vessel having an upper portion wherein the upper portion includes an opening, a first baffle and an outlet, an upper stripping zone having a first inlet and a second baffle and a lower cooling zone having a second inlet, a third baffle, and a bottom opening,
wherein the upper stripping zone is in fluid communication with the lower cooling zone.
30

7. The apparatus of claim 6, wherein the first baffle is a conical baffle having a top portion that is connected to the inside of the vessel and a bottom portion that is truncated and provides an opening.
- 5 8. The apparatus of claim 6, wherein the second baffle is a cylindrical baffle having a top portion which extends inward from the vessel and curves downward.
9. The apparatus of claim 6, wherein the third baffle is a conical baffle having a top portion that is connected to the inside of the vessel and a bottom portion that is truncated
10 and provides an opening.
10. The apparatus of claim 6, further comprising a second outlet in the lower cooling zone.

1/2

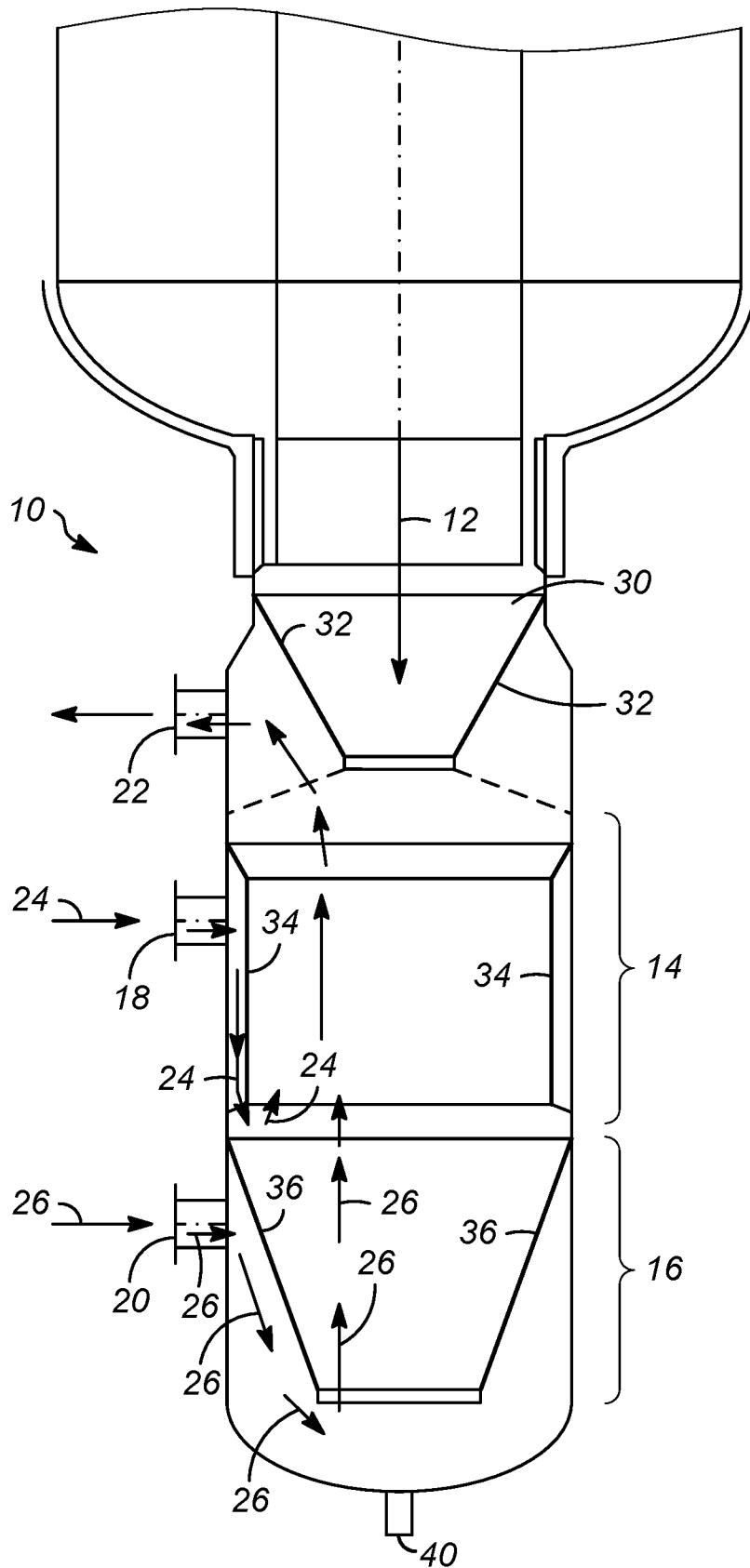

FIG. 1

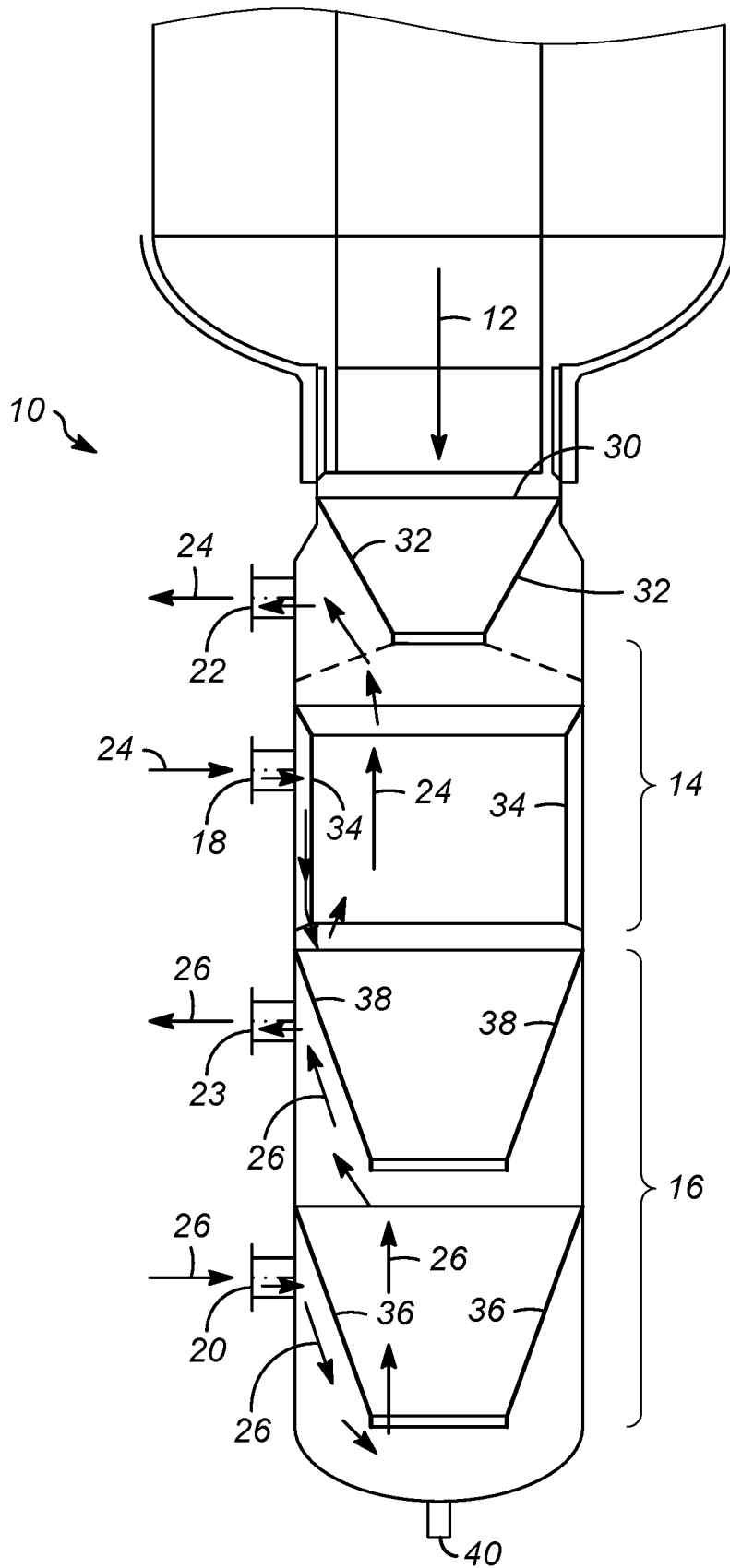

FIG. 2

INTERNATIONAL SEARCH REPORT

International application No.

PCT/US 2016/037558

| A. CLASSIFICATION OF SUBJECT MATTER | | |
|---|---|--|
| <i>B01J 38/02 (2006.01)</i> <i>B01J 38/04 (2006.01)</i> <i>B01J 19/24 (2006.01)</i> | | |
| According to International Patent Classification (IPC) or to both national classification and IPC | | |
| B. FIELDS SEARCHED | | |
| Minimum documentation searched (classification system followed by classification symbols) | | |
| B01J 19/24, 38/02, 38/04 | | |
| Documentation searched other than minimum documentation to the extent that such documents are included in the fields searched | | |
| Electronic data base consulted during the international search (name of data base and, where practicable, search terms used) | | |
| PatSearch (RUPTO internal), USPTO, PAJ, Esp@cenet, DWPI, EAPATIS, PATENTSCOPE | | |
| C. DOCUMENTS CONSIDERED TO BE RELEVANT | | |
| Category* | Citation of document, with indication, where appropriate, of the relevant passages | Relevant to claim No. |
| X | US 4917790 A (MOBIL OIL CORPORATION) 17.04.1990, claims, col. 5, lines 10-20, col. 7, lines 24-68, col. 8, lines 1-14, col. 9, lines 1-5 | 1-5 |
| A | | 6-10 |
| A | US 8173567 B2 (UOP LLC) 08.05.2012 | 1-10 |
| A | WO 2013/142044 A2 (UOP LLC) 26.09.2013 | 1-10 |
| A | US 4820404 A (MOBIL OIL CORPORATION) 11.04.1989 | 1-10 |
| <input type="checkbox"/> Further documents are listed in the continuation of Box C. <input type="checkbox"/> See patent family annex. | | |
| * Special categories of cited documents: | “T” | later document published after the international filing date or priority date and not in conflict with the application but cited to understand the principle or theory underlying the invention |
| “A” document defining the general state of the art which is not considered to be of particular relevance | “X” | document of particular relevance; the claimed invention cannot be considered novel or cannot be considered to involve an inventive step when the document is taken alone |
| “E” earlier document but published on or after the international filing date | “Y” | document of particular relevance; the claimed invention cannot be considered to involve an inventive step when the document is combined with one or more other such documents, such combination being obvious to a person skilled in the art |
| “L” document which may throw doubts on priority claim(s) or which is cited to establish the publication date of another citation or other special reason (as specified) | “&” | document member of the same patent family |
| “O” document referring to an oral disclosure, use, exhibition or other means | | |
| “P” document published prior to the international filing date but later than the priority date claimed | | |
| Date of the actual completion of the international search | Date of mailing of the international search report | |
| 06 October 2016 (06.10.2016) | 20 October 2016 (20.10.2016) | |
| Name and mailing address of the ISA/RU: Federal Institute of Industrial Property, Berezhkovskaya nab., 30-1, Moscow, G-59, GSP-3, Russia, 125993 Facsimile No: (8-495) 531-63-18, (8-499) 243-33-37 | Authorized officer E. Zelenina Telephone No. 8-499-240-25-91 | |