



US00D923665S

(12) **United States Design Patent**  
**Wang**

(10) **Patent No.:** **US D923,665 S**

(45) **Date of Patent:** **\*\* Jun. 29, 2021**

(54) **CAR AIR PUMP**

(71) Applicant: **Quanfei Wang**, Zhejiang (CN)

(72) Inventor: **Quanfei Wang**, Zhejiang (CN)

(\*\*) Term: **15 Years**

(21) Appl. No.: **29/741,821**

(22) Filed: **Jul. 16, 2020**

(51) **LOC (13) Cl.** ..... **15-02**

(52) **U.S. Cl.**  
USPC ..... **D15/7**

(58) **Field of Classification Search**

USPC ..... D15/7-9, 144.1; D23/225, 231, 232,  
D23/366, 356; D12/114; D14/139, 154,  
D14/155, 196, 209.1, 214, 221; D24/108,  
D24/110, 168, 170, 231, 232  
CPC ..... F04B 53/14; F04B 53/92; F04B 33/00;  
F04B 33/005; F04B 1/005; F04B 39/102;  
F04D 13/06; F04D 29/22; F04D 29/046;  
F04D 29/2266; F16K 11/048; F16K  
15/20; F16K 31/602; F16L 37/18; F16L  
37/20

See application file for complete search history.

(56) **References Cited**

**U.S. PATENT DOCUMENTS**

D295,181 S *	4/1988	Vitaloni	.....	D15/9
D296,104 S *	6/1988	Hung	.....	D15/9
D301,887 S *	6/1989	Price	.....	D15/7
D340,726 S *	10/1993	Wang	.....	D15/7
D388,789 S *	1/1998	Kokkinis	.....	D14/194
D403,330 S *	12/1998	Williams	.....	D15/9
D407,413 S *	3/1999	Wang	.....	D15/9
D466,908 S	12/2002	Poon	.....	
D484,890 S *	1/2004	Hsiao	.....	D15/9
D491,196 S	6/2004	Poon	.....	
D498,469 S *	11/2004	Ashfield	.....	D14/188
D518,078 S *	3/2006	Persson	.....	D15/144.1
D540,826 S *	4/2007	Wang	.....	D15/9
D541,309 S *	4/2007	Wang	.....	D15/9

D548,751 S *	8/2007	Snider	.....	D15/7
D555,472 S *	11/2007	Gedanke	.....	D9/418
D572,273 S *	7/2008	Carpenter	.....	D15/7
D589,533 S	3/2009	Anderson	.....	
D597,105 S *	7/2009	Geisler	.....	D15/9
D641,344 S *	7/2011	Thomas	.....	D14/242
D707,719 S *	6/2014	Kamijyo	.....	D15/7
D771,017 S *	11/2016	Sasaki	.....	D14/214
D777,231 S *	1/2017	Ide	.....	D15/144
D797,078 S *	9/2017	Nugent	.....	D14/214
D814,525 S	4/2018	Yang	.....	
D817,362 S	5/2018	Kennedy et al.	.....	
D826,282 S *	8/2018	Mead	.....	D15/7
D830,415 S	10/2018	Kennedy et al.	.....	

(Continued)

**OTHER PUBLICATIONS**

Campbell Hausfeld, RP410099AV Home Inflation System, (first available Jul. 20, 2011), Amazon.com, URL:<https://www.amazon.com/Campbell-Hausfeld-RP410099AV-Inflation-System/dp/B005CMHUA4> (Year: 2011).\*

*Primary Examiner* — Sheryl Lane

*Assistant Examiner* — Mark T. Philipps

(57) **CLAIM**

The ornamental design for a car air pump, as shown and described.

**DESCRIPTION**

FIG. 1 is a perspective view of a car air pump showing my new design;  
FIG. 2 is a front elevation view thereof;  
FIG. 3 is a rear elevation view thereof;  
FIG. 4 is a left side elevation view thereof;  
FIG. 5 is a right side elevation view thereof;  
FIG. 6 is a top plan view thereof; and,  
FIG. 7 is a bottom plan view thereof.  
The broken lines depict portions of the car air pump that form no part of the claimed design.

**1 Claim, 7 Drawing Sheets**

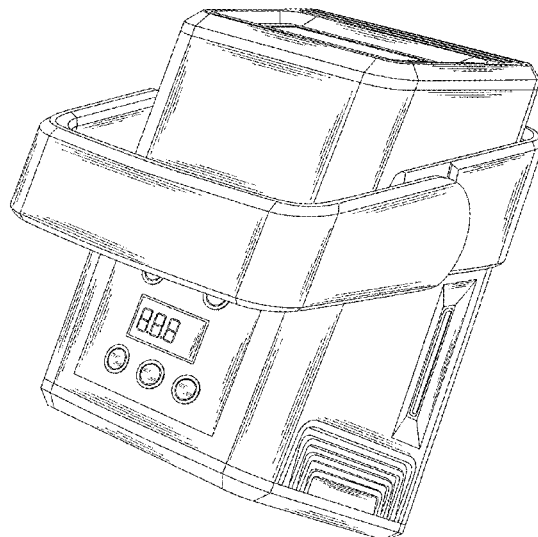

(56)

**References Cited**

U.S. PATENT DOCUMENTS

D830,417 S	10/2018	Sekula et al.	
D854,188 S *	7/2019	Schaeken .....	D24/232
D869,507 S	12/2019	Huang et al.	
D878,423 S *	3/2020	Andersson .....	D15/7
D888,013 S *	6/2020	Yu .....	D14/214
D896,281 S *	9/2020	Long .....	D15/9
D896,847 S *	9/2020	Janardhan .....	D15/7

\* cited by examiner

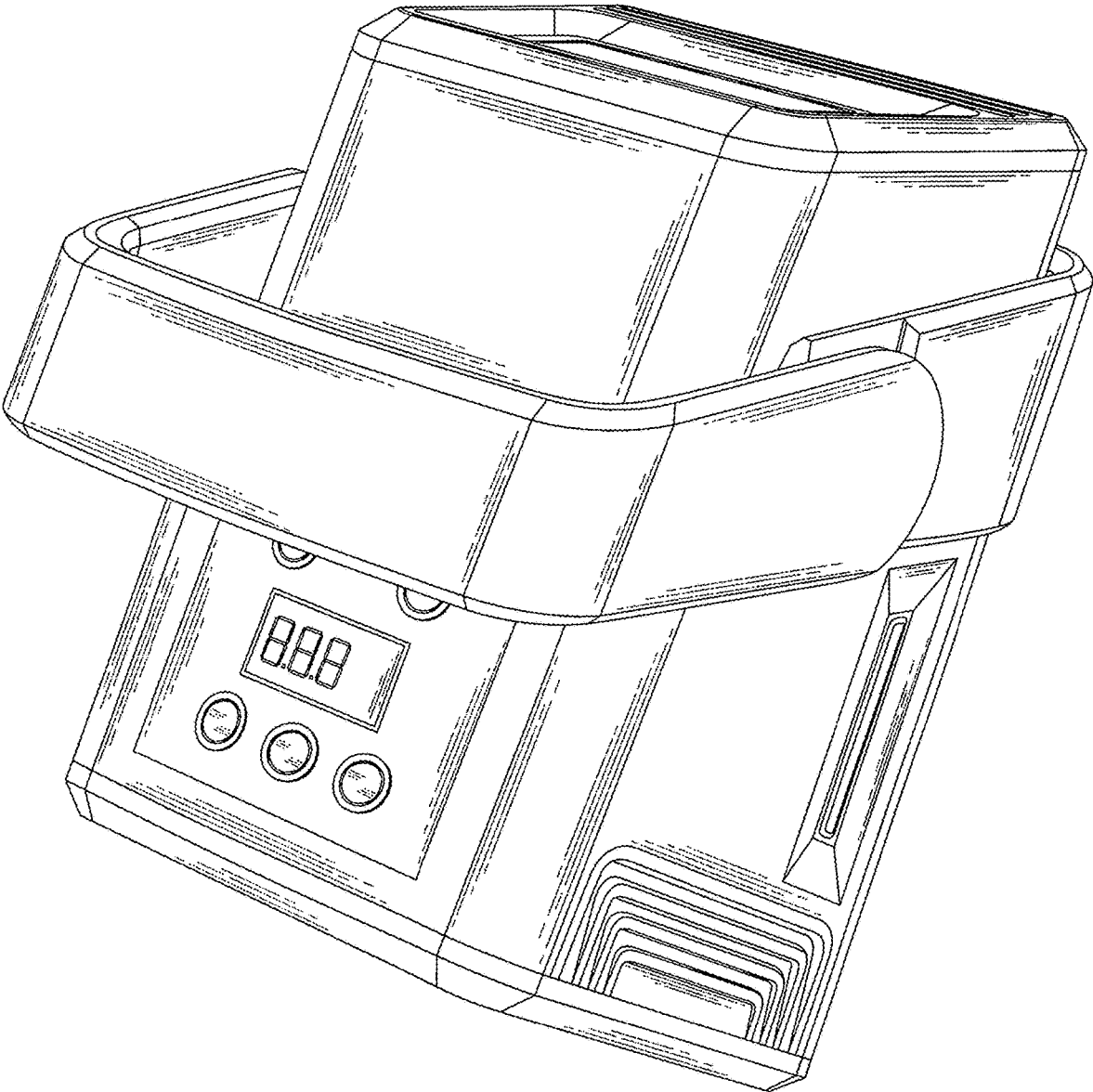

FIG. 1

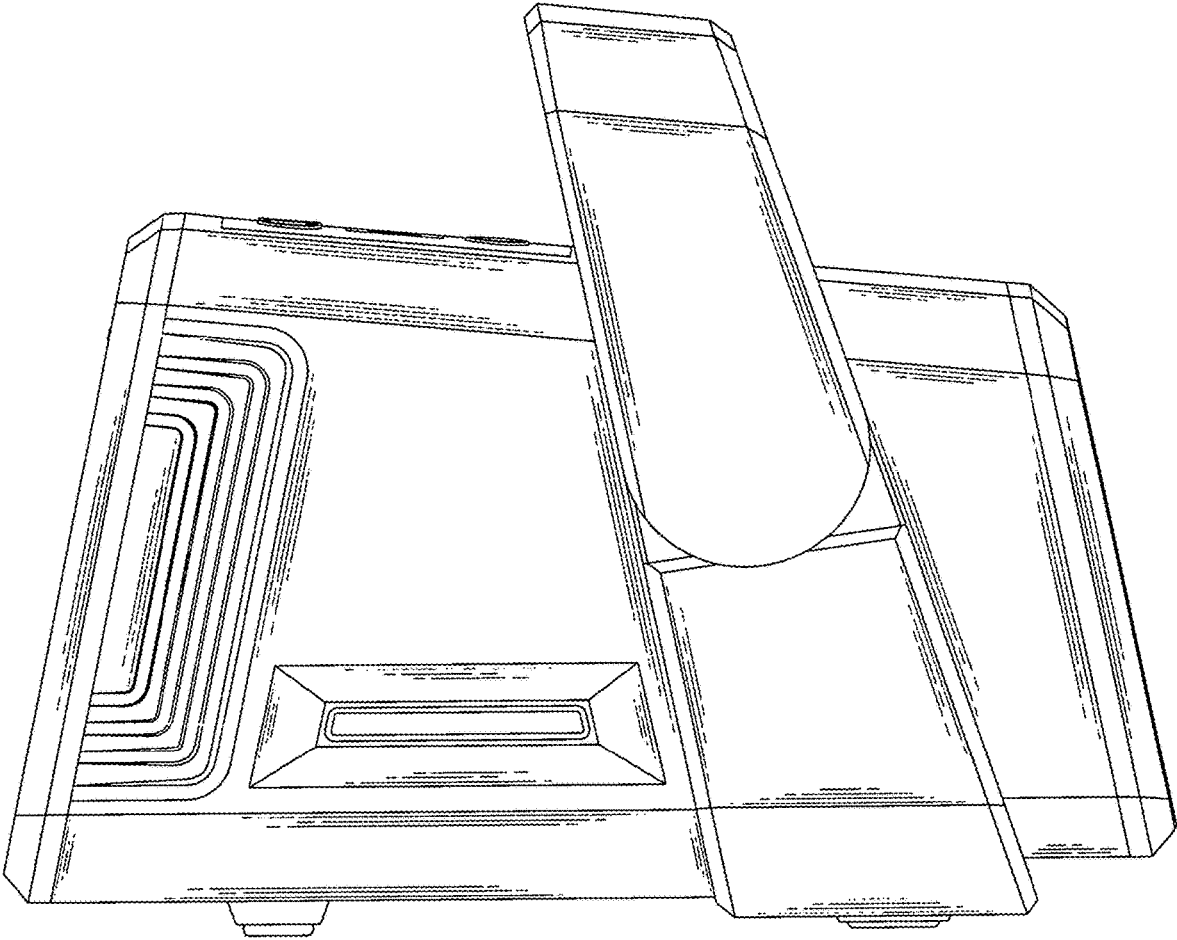

FIG. 2

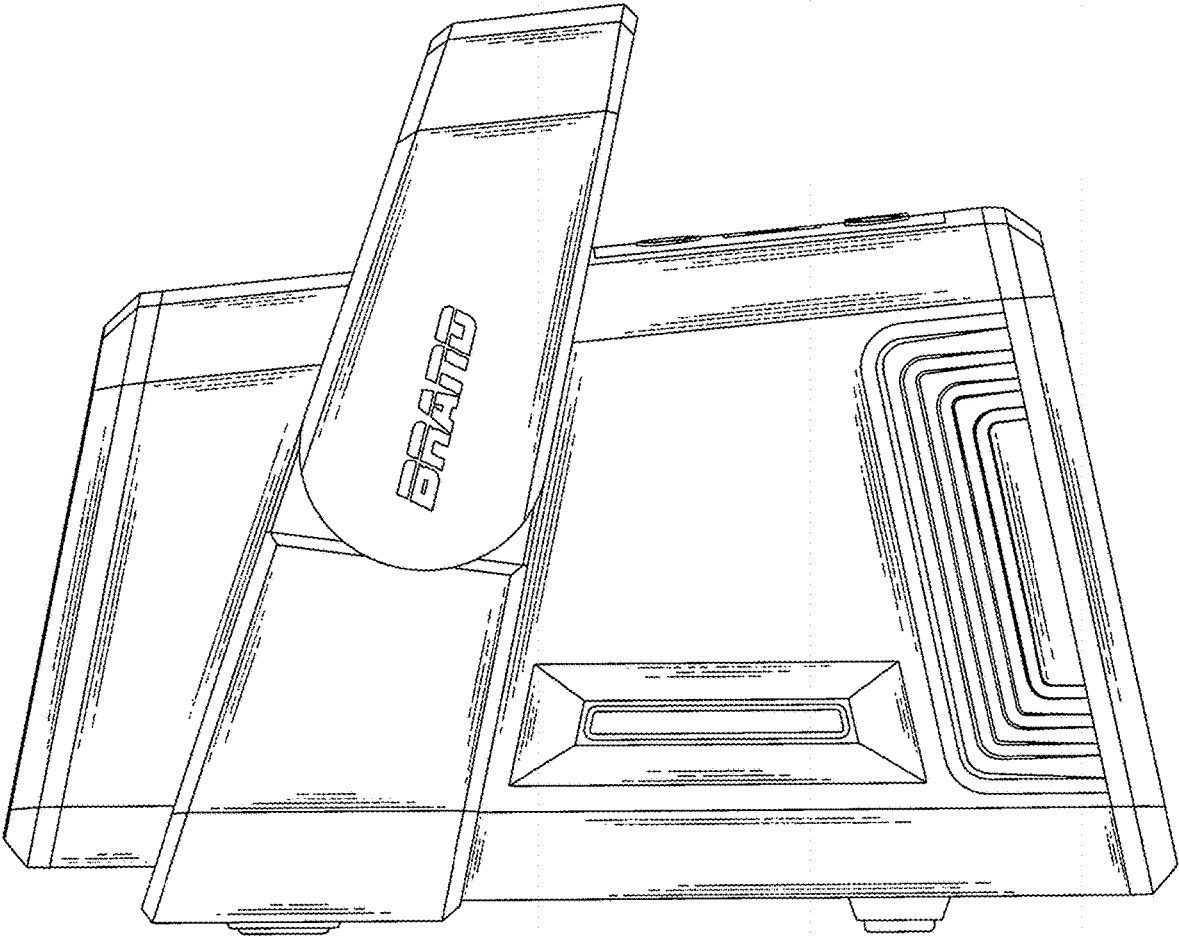

FIG. 3

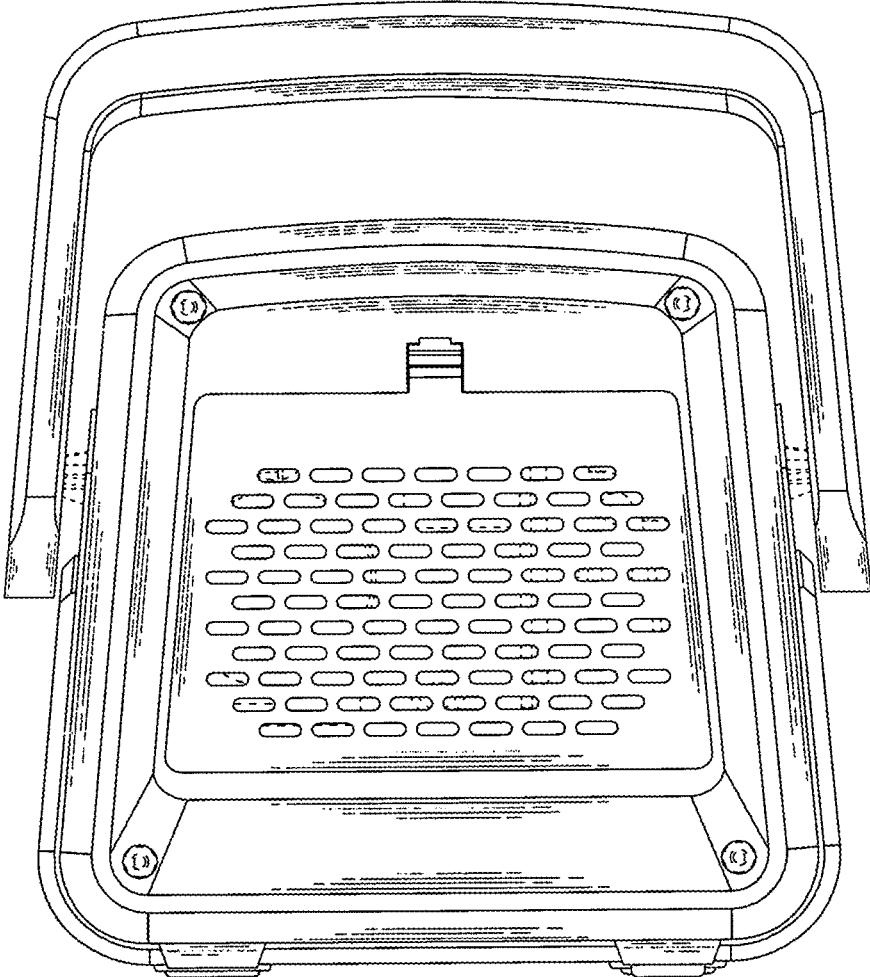

FIG. 4

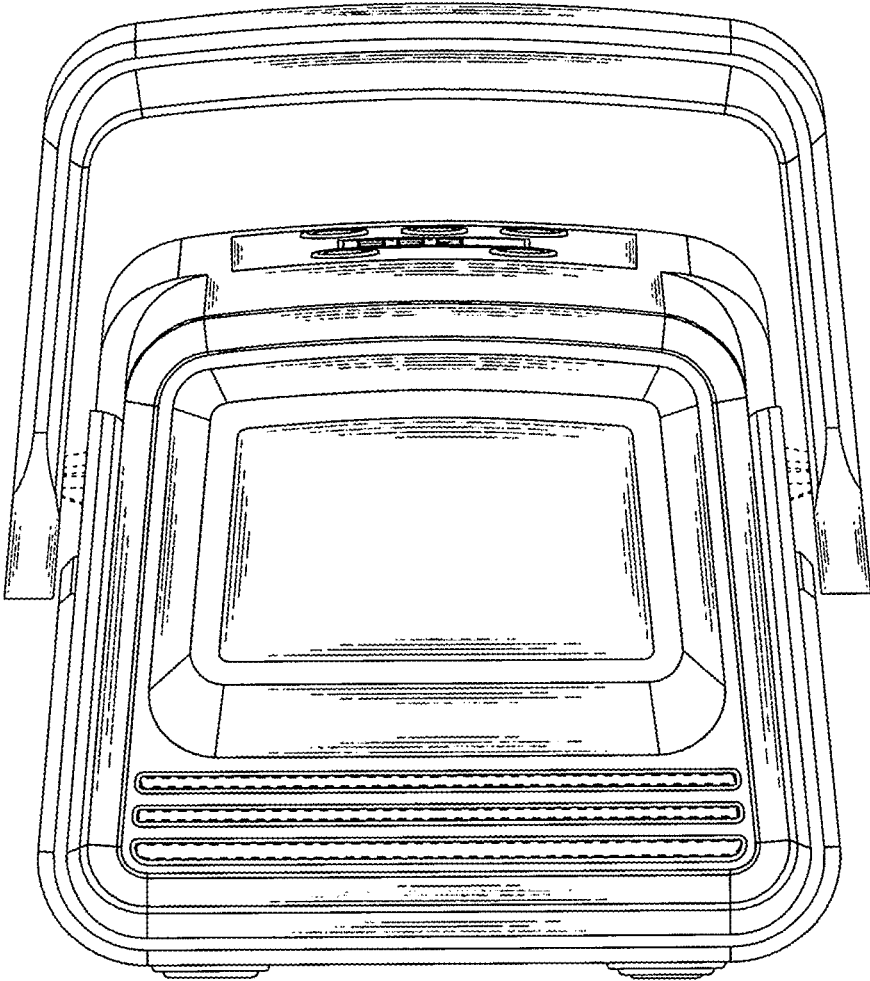

FIG. 5

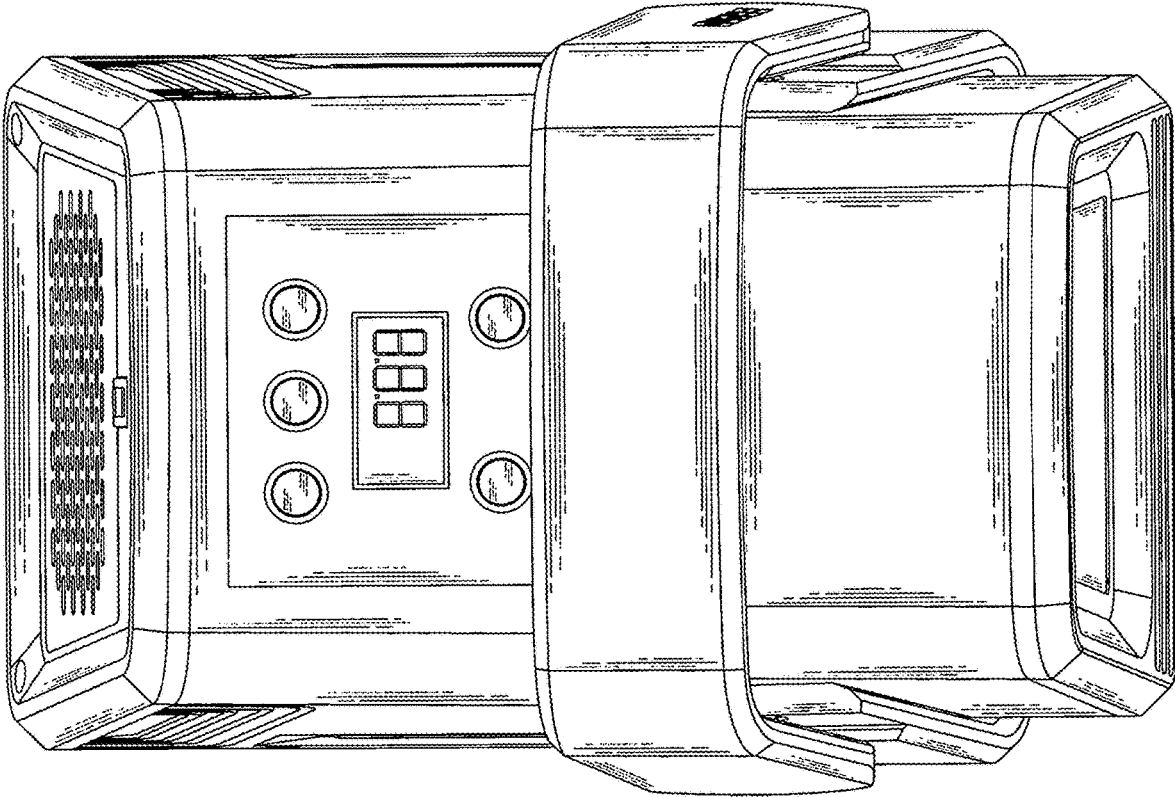

FIG. 6



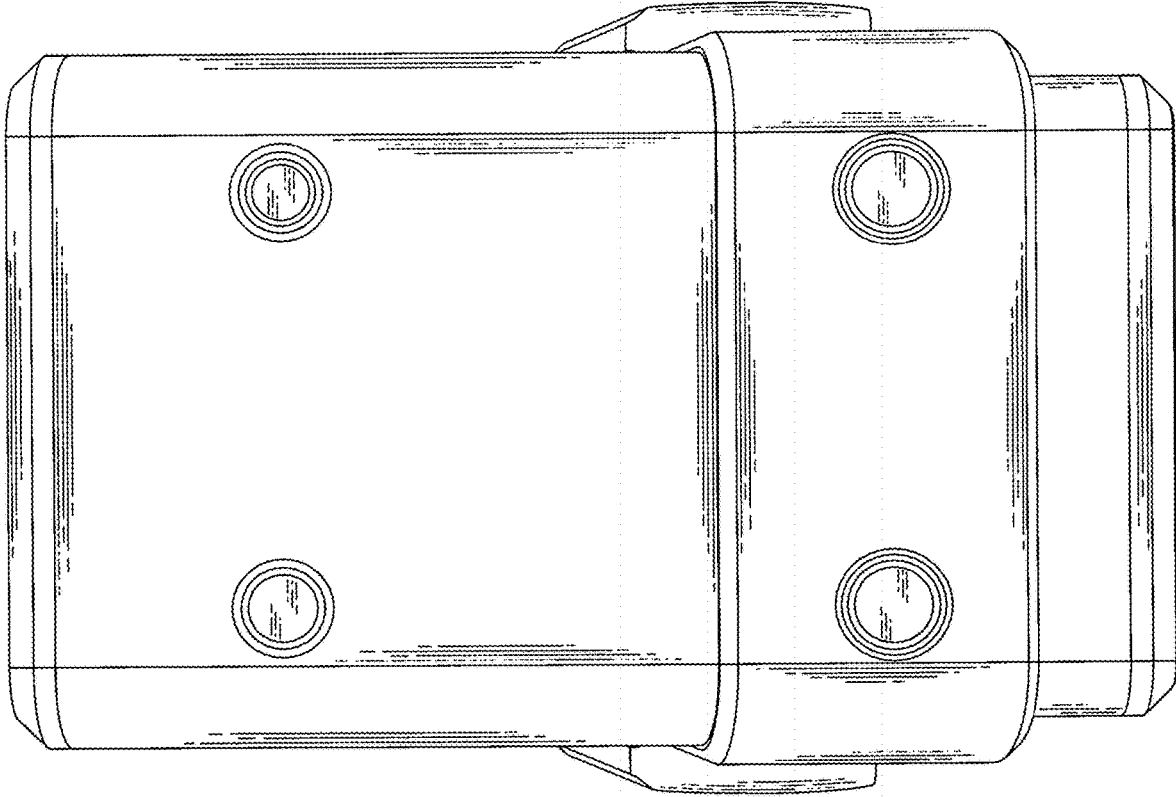

FIG. 7