

No. 842,751.

PATENTED JAN. 29, 1907.

J. A. BEXELL.
TEMPORARY BINDER.
APPLICATION FILED APR. 23, 1906.

3 SHEETS—SHEET 1.

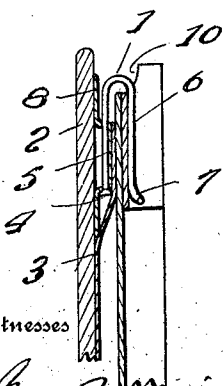
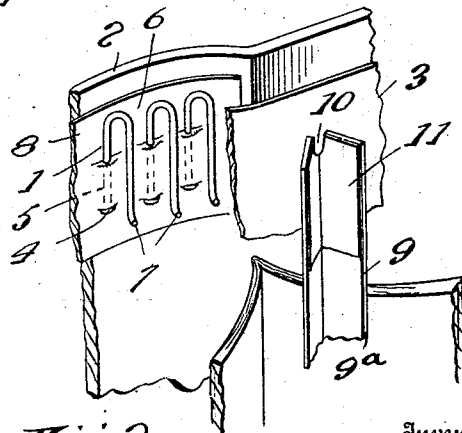
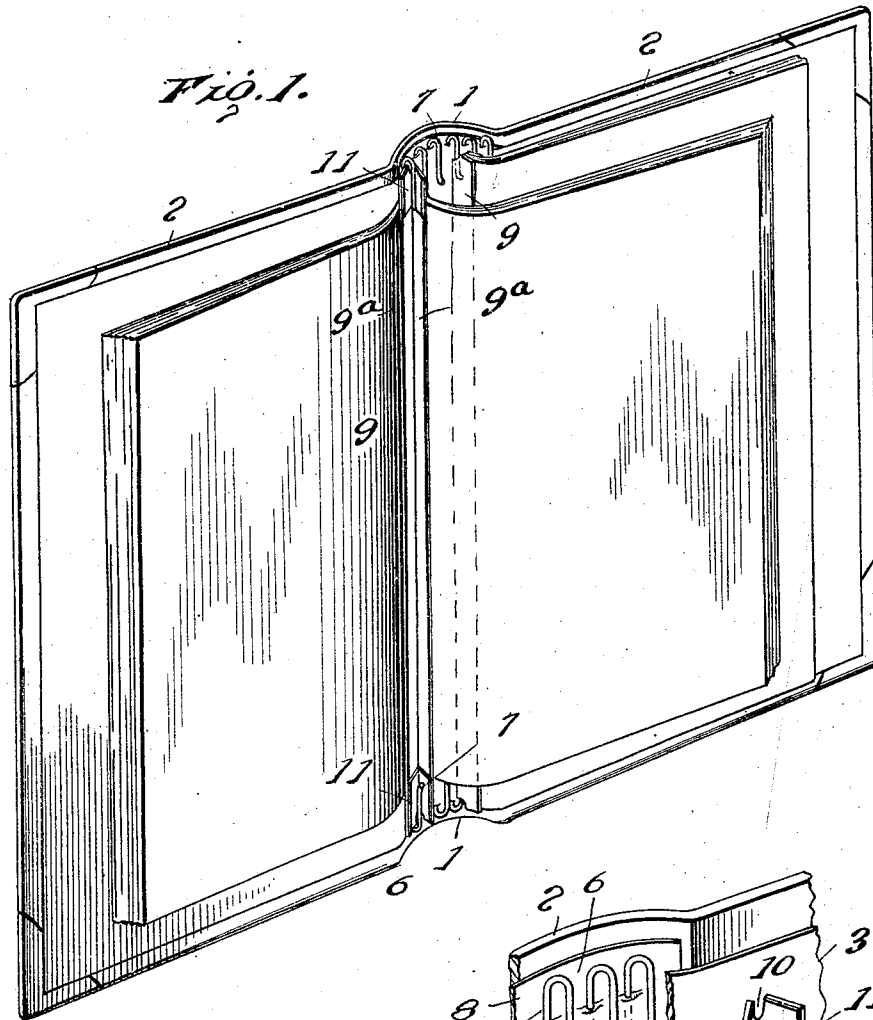

Fig. 3.

Fig. 2.

Inventor

J. A. Bexell

Witnesses

J. A. Bexell
W. J. Woodson

By

W. A. Macer, Attorneys

J. A. BEXELL.
TEMPORARY BINDER.
APPLICATION FILED APR. 23, 1906.

Fig. 4.

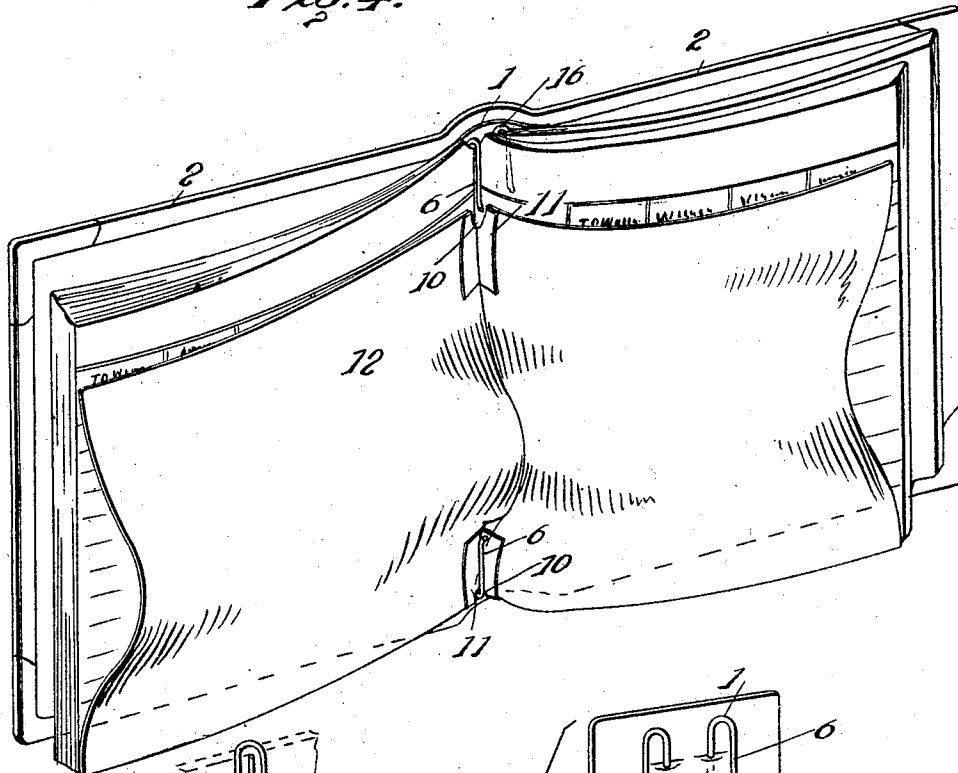

Fig. 5.

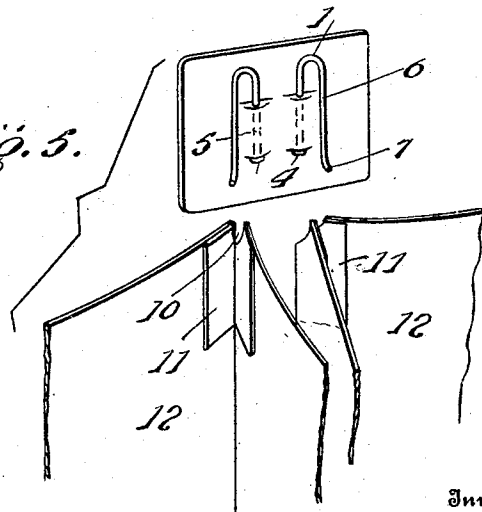

Fig. 15

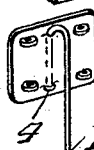
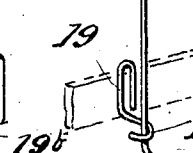
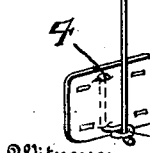
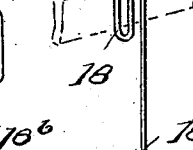

Fig. 14



Witnesses

J. A. Bexell
W. N. Woodson

Inventor

J. A. Bexell

By

Th. M. Coey, Attorneys

J. A. BEXELL.
TEMPORARY BINDER.
APPLICATION FILED APR. 23, 1906.

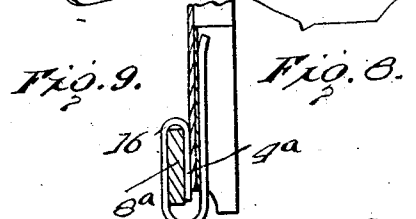
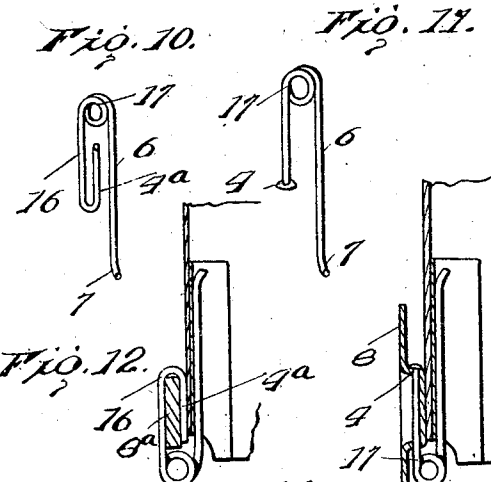
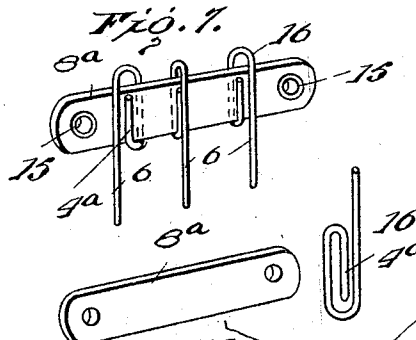
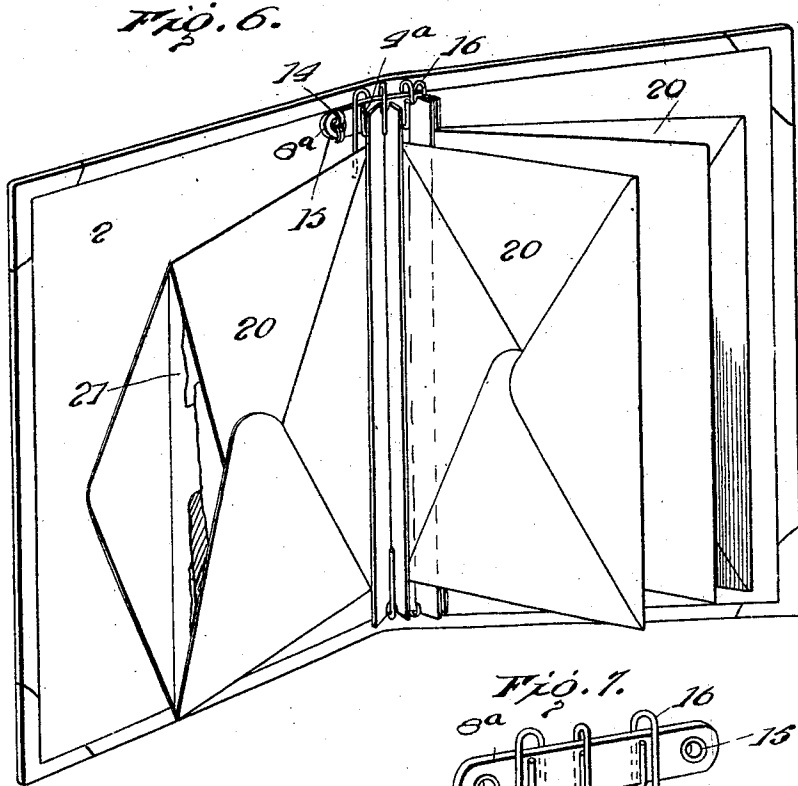

Witnesses
M. Woodson

Inventor
 J. A. Bexell
 By *H. A. Macy*, Attorneys.

UNITED STATES PATENT OFFICE.

JOHN A. BEXELL, OF LOGAN, UTAH.

TEMPORARY BINDER.

No. 842,751.

Specification of Letters Patent.

Patented Jan. 29, 1907.

Application filed April 23, 1906. Serial No. 313,310.

To all whom it may concern:

Be it known that I, JOHN A. BEXELL, a citizen of the United States, residing at Logan, in the county of Cache and State of Utah, have invented certain new and useful Improvements in Temporary Binders, of which the following is a specification.

My invention contemplates certain new and useful improvements in temporary binders, and is applicable for holding, in convenient position for handling, magazines, newspapers, or other periodicals or pamphlets or the like or loose leaves between protecting-covers in position for ready detachment and replacing whenever desired.

The object of the invention is to provide a temporary binder of this general nature which will be simple in construction and of a minimum of parts and which will be adapted to hold loose or bound-together leaves within protecting-covers in such a manner that they may be expeditiously and easily detached and replaced and in which the said leaves will be held within the covers without becoming worn by the attaching devices forming parts of my invention.

The invention consists in certain constructions and arrangements of parts and modifications thereof, as will be hereinafter fully described and claimed.

For a full description of the invention and the merits thereof and also to acquire a knowledge of the details of construction of the means for effecting the result reference is to be had to the following description and accompanying drawings, in which—

Figure 1 is a perspective view illustrating one embodiment of my invention. Fig. 2 is a detail fragmentary perspective view showing the parts detached from each other and in juxtaposition. Fig. 3 is a detail sectional view of that form of the temporary binder illustrated in Fig. 1. Fig. 4 is a perspective view illustrating that modification of the invention particularly adapted for use as a loose-leaf binder. Fig. 5 is a detail perspective view and fragmentary view of some of the parts shown in Fig. 4 detached from each other. Fig. 6 is a detail perspective view showing other modifications. Fig. 7 is a detail perspective view of a portion of the modified form of the binder illustrated in Fig. 6. Fig. 8 illustrates in detail perspective and side view, respectively, one of the supporting-strips and fasteners. Fig. 9 illustrates in de-

tail sectional view the application of the parts shown in Figs. 7 and 8. Figs. 10 and 11 are detail perspective views of two forms of fasteners employed. Figs. 12 and 13 are detail sectional views illustrating the application of the fasteners shown in Figs. 10 and 11, respectively. Fig. 14 is a detail perspective view illustrating another modified form of fasteners. Fig. 15 is a detail perspective view illustrating still another modified form of fastener.

Corresponding and like parts are referred to in the following description and indicated in all the views of the drawings by the same reference characters.

In one and possibly the most simple form or embodiment of my invention fasteners 1 are employed at both top and bottom edges of the protecting-covers 2 and at the middle or meeting portions of said covers. The covers 2 may be composed of any desired material, either stiff or flexible, and they are usually, as is customary, joined together by the flexible connecting-web 3. As shown in the drawings, the said fasteners 1 are constituted by pins having heads 4 at one end, preferably straight attaching-shanks 5, and inwardly-extending returned or bent portions 6, bent slightly outward beyond the heads 4 at their extremities, as indicated at 7. The said extremities are preferably blunt. It will be noted, therefore, that the fasteners 1 are substantially U shape. The fasteners 1 are secured to supporting-strips 8 of leather or any suitable material, and in the embodiment of the invention now being described the said fasteners are inserted through the thickness of the supporting-strips first outwardly and then inwardly and in a general direction at right angles to the top and bottom edges of the protecting-covers, the open sides of the upper set of U-shaped fasteners 1 facing downwardly and the fasteners of the lower set facing upwardly, as clearly shown in the drawings. As many of these fasteners 1 as may be desired may be secured to the respective supporting-strips 8.

If it be desired to temporarily bind a periodical between the protecting-covers 2, there is preferably provided in connection with the fastener 1 a protective strip 9, which comprises two sections 9^a, connected together along their longitudinal edges or integral with each other, as shown, and of any desired material sufficiently stiff for the pur-

pose. For instance, a light-weight cardboard or stiff Manila paper may be used. Each protecting-strip 9 is provided at each end with a recess 10 and is also preferably provided at its ends with reinforce-sections 11, of linen or similar durable and tenacious material. The reinforces 11 are preferably located only on the inner sides of the sections 9^a of the protecting-strips 9 at the ends thereof and at the joint between said sections and are preferably of a length equal to or greater than the length of the portions 6 of the fasteners 1. The reinforces are designed to receive the wear of the fastener as well as to prevent the ends of the protective strips 9 from splitting. In practice when the protective strips 9 are employed the periodical or periodicals are placed between the protecting-covers 2 and are opened, preferably at about their middle, and are inserted at their upper and lower edges underneath or into correspondingly opposite top and bottom fasteners. The protective strip 9 is then applied in a manner that is manifest, and preferably when used with a pamphlet, periodical, or the like the protective strips are of marginal width only—that is, they are not full pages, but are of a width which is not calculated to extend over the reading matter. If it be desired to use this embodiment of my invention as a loose-leaf binder, it may be preferred to employ protective strips 12, as illustrated in Fig. 4, said strips 12 being substantially like the protective strips 9, except that the strips 12 are full pages and are used as filler-in sheets between every two sections. Protective strips or sheets 12 not only assist in holding the loose leaves in position, but they protect said leaves from the wear of the fasteners just as the protective strips 9 do. Fig. 4 also illustrates how the loose or bound sheets may be inserted within and detached from the temporary binder embodying the improvements of my invention, it being understood from said view that the sheets are doubled transversely at about the middle of their height, as shown, and then slipped first one edge and then the other underneath the fastening-pins. The said view also shows that the loose sheets themselves, as well as the filler-in sheets or protective strips may, if desired, be provided with recesses at top and bottom edges, so as to prevent the loose sheets, or the periodical or the like, from moving sidewise in the protective covers when secured between the same by my devices.

The fasteners 1, as well as the other fasteners hereinafter described, are preferably composed of spring brass wire, although it is manifest that my invention is not limited to the employment of this material.

The supporting-strips 8 may be glued or stitched at their ends between the protecting-

covers 2, and, as illustrated in Fig. 3, they may be covered by the ordinary flexible fabric strip 3, the portions 6 of the fasteners extending on the outside of such fabric. Instead of gluing or sewing the supporting-strips 8 in place they may be provided, as shown in Fig. 6, at each end with an aperture designed to receive a temporary fastener 14, extending through the protecting-covers 2, and the apertures may be provided with metallic or other eyelets 15 or not, just as desired. When the supporting-strips are fastened as just now described, it is evident that they may be detached at either or both ends. Preferably with these means of fastening the supporting-strips, which are here designated 8^a, I may employ in lieu of the fasteners 1 fasteners 16. As illustrated in Fig. 7, the fasteners 16 are provided, instead of heads, with returned ends 4^a, designed to embrace and be slidably mounted upon the supporting-strips 8^a, so that they may be detached therefrom by unfastening either end or both ends of said strips. Both the fasteners 1 and fasteners 16 may be provided with coils 17, as illustrated in Figs. 10 and 11, or such coils may be omitted, if desired.

In the modification illustrated in Fig. 14 the fastening devices comprise complementary members 18 and 19, arranged at top and bottom of the protecting-covers and secured in any manner to the supporting-strips, the member 18 being extended, as indicated at 18^a, to project entirely across the magazine or pamphlet secured in the binder and arranged for detachable engagement with a hook 19^a on the other member 19. This modification is particularly adapted for use in binding magazines or pamphlets which are stapled longitudinally. The members 18 and 19 may either or both be provided with coils, if desired; but the same are not essential.

As illustrated in Fig. 15, the supporting-strips which the fasteners are designed to pierce may be stapled to the parts to which they are to be attached. This view also shows that the fasteners (here designated 18^b and 19^b) are similar in some respects to the fasteners 18 and 19 and may be provided with heads 4 like the fasteners 1 before described instead of the loops shown in Fig. 14.

In still another modification of my invention the leaves 20, as illustrated in Fig. 6, may be constituted by envelopes or the like 21, providing pockets for the reception of clippings, so as to produce a scrap-book or similar device. Every two opposite leaves constituted by the envelopes 21 or similar receptacles are connected together, the connection either being an integral one or through the instrumentality of independent securing devices, and they may be held in at top and bottom edges with the same fastening device and protective strips or sheets that are used

in other modifications of my invention, or the envelopes themselves may serve as protective strips or sheets.

From the foregoing description, in connection with the accompanying drawings, it will be seen that I have provided an improved temporary binder capable of a variety of uses and embodying novel and useful features which result in a device of this character possessing the characteristics of simplicity, durability, and effectiveness of operation.

Having thus described the invention, what is claimed as new is—

1. A temporary binder, comprising protecting-covers, U-shaped fasteners secured at top and bottom edges of said cover at the middle thereof, said fasteners facing each other, and protective strips designed for insertion at their ends underneath the oppositely-facing fasteners, and designed to secure to said fasteners loose or bound-together leaves.

2. A temporary binder, comprising protecting-covers, U-shaped fasteners secured at top and bottom of said covers at the middle thereof, the open sides of said fasteners facing each other, top and bottom fasteners being considered, supporting-strips to which said fasteners are directly attached, and protective strips designed to have their ends in-

serted under the said fasteners, as and for the purpose specified.

3. A temporary binder, comprising protecting-covers, an upper and a lower set of U-shaped fasteners secured to said cover at the middle thereof, and protective strips provided at their ends with reinforces and designed to be inserted under said fasteners at their ends.

4. A temporary binder comprising protecting-covers, an upper and a lower set of U-shaped fasteners secured to said cover at the middle thereof, and protective strips provided at their ends with reinforces and recesses and designed to be inserted at their ends under said fasteners.

5. A temporary binder comprising protecting-covers, supporting-strips secured to said covers at top and bottom at the middle thereof, and fasteners provided with returned ends ⁴ designed to embrace said supporting-strips whereby to detachably connect the fasteners to said strips.

In testimony whereof I affix my signature in presence of two witnesses.

JOHN A. BEXELL. [L. s.]

Witnesses:

J. L. COBURN,
D. M. STEPHENS.