



US 20170056156A1

(19) **United States**

(12) **Patent Application Publication**
RYAN

(10) **Pub. No.: US 2017/0056156 A1**

(43) **Pub. Date: Mar. 2, 2017**

(54) **APPARATUS AND METHODS FOR
ENDOLUMINAL GRAFT PLACEMENT**

(71) Applicant: **Timothy J. RYAN**, San Pedro, CA
(US)

(72) Inventor: **Timothy J. RYAN**, San Pedro, CA
(US)

(21) Appl. No.: **15/349,758**

(22) Filed: **Nov. 11, 2016**

Related U.S. Application Data

(60) Continuation of application No. 13/928,280, filed on Jun. 26, 2013, which is a division of application No. 13/281,973, filed on Oct. 26, 2011, now abandoned, which is a division of application No. 08/463,836, filed on Jun. 5, 1995, now Pat. No. 8,206,427, which is a division of application No. 08/255,681, filed on Jun. 8, 1994, now abandoned.

Publication Classification

(51) **Int. Cl.**
A61F 2/07 (2006.01)
A61F 2/954 (2006.01)
A61F 2/915 (2006.01)
(52) **U.S. Cl.**
CPC *A61F 2/07* (2013.01); *A61F 2/915*
(2013.01); *A61F 2/954* (2013.01); *A61F*
2002/067 (2013.01)

(57) **ABSTRACT**

A vascular graft comprises a perforate tubular compressible frame having a fabric liner disposed over at least a portion of the frames lumen. The graft may be used in combination with a base structure to form a bifurcated graft in situ. The base structure compresses a compressible frame having a fabric liner which defines a pair of divergent legs. The base structure is positioned within the aorta so that one leg enters each iliac. The tubular grafts can then be introduced into each leg to form the bifurcated structure. A graft delivery catheter includes a controllably flared sheath which facilitates recapture of a partially deployed graft.

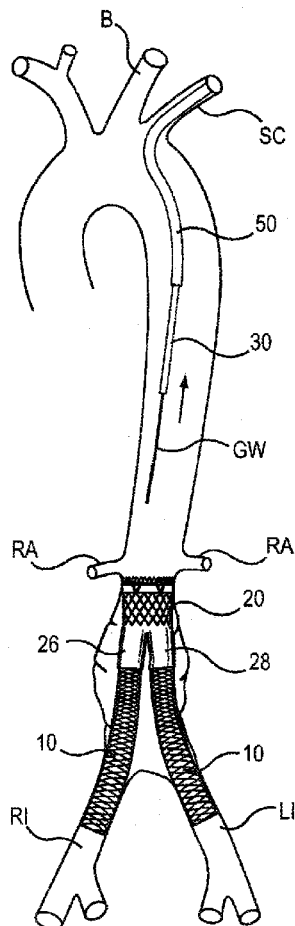

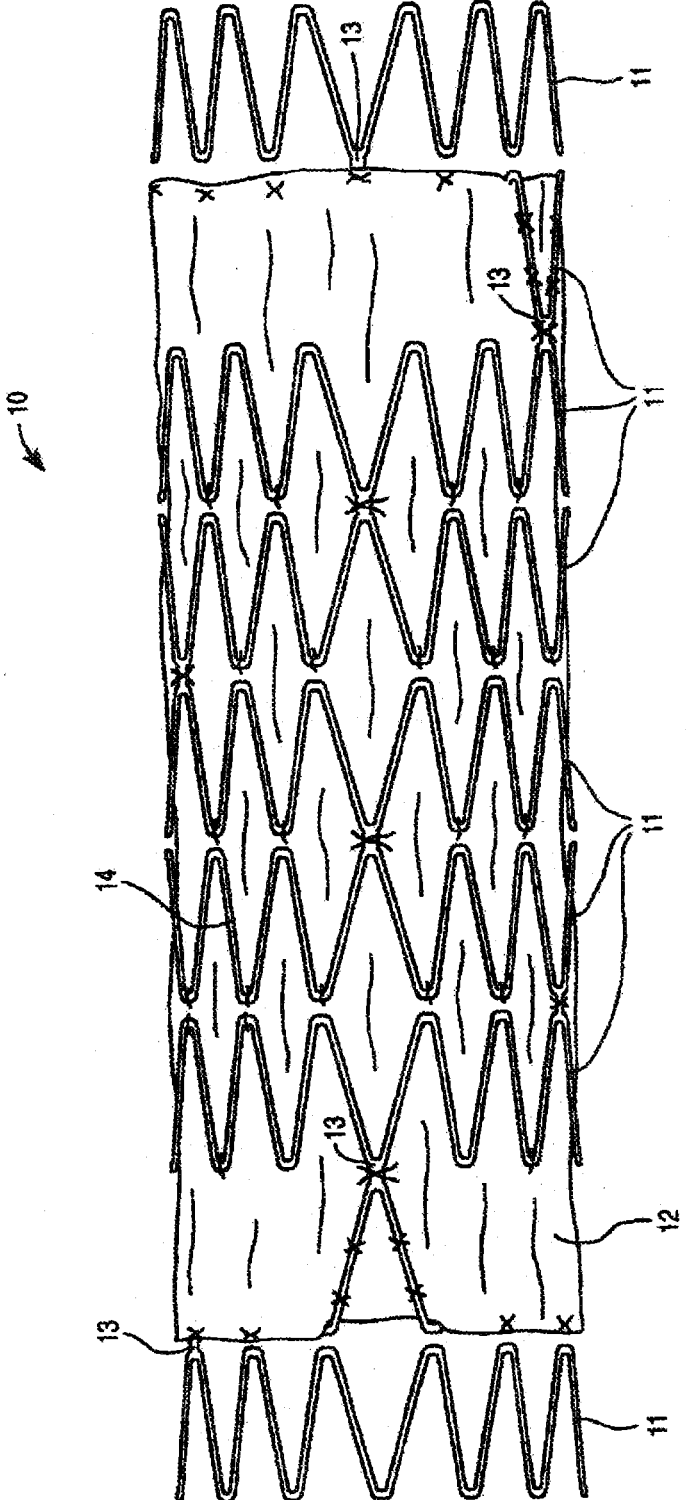

FIG. 1

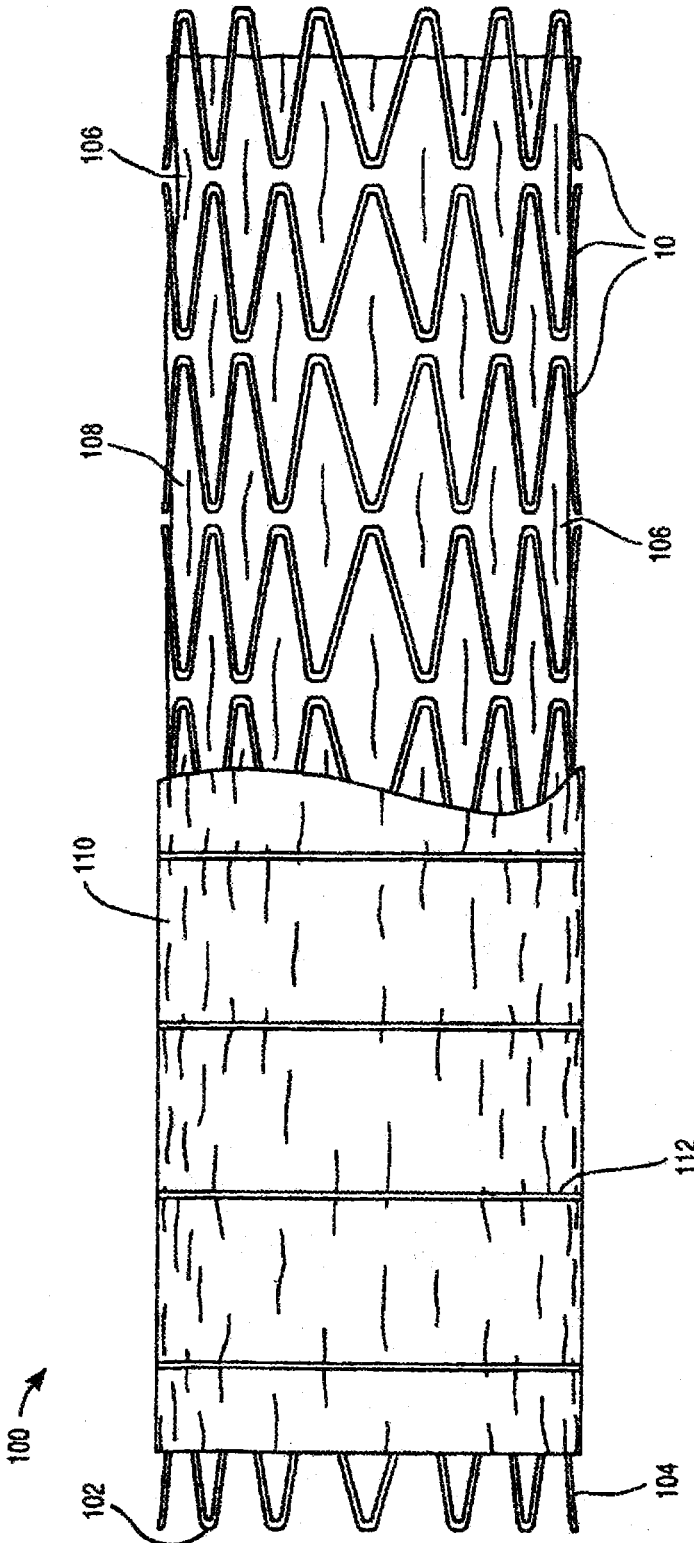

FIG. 1A

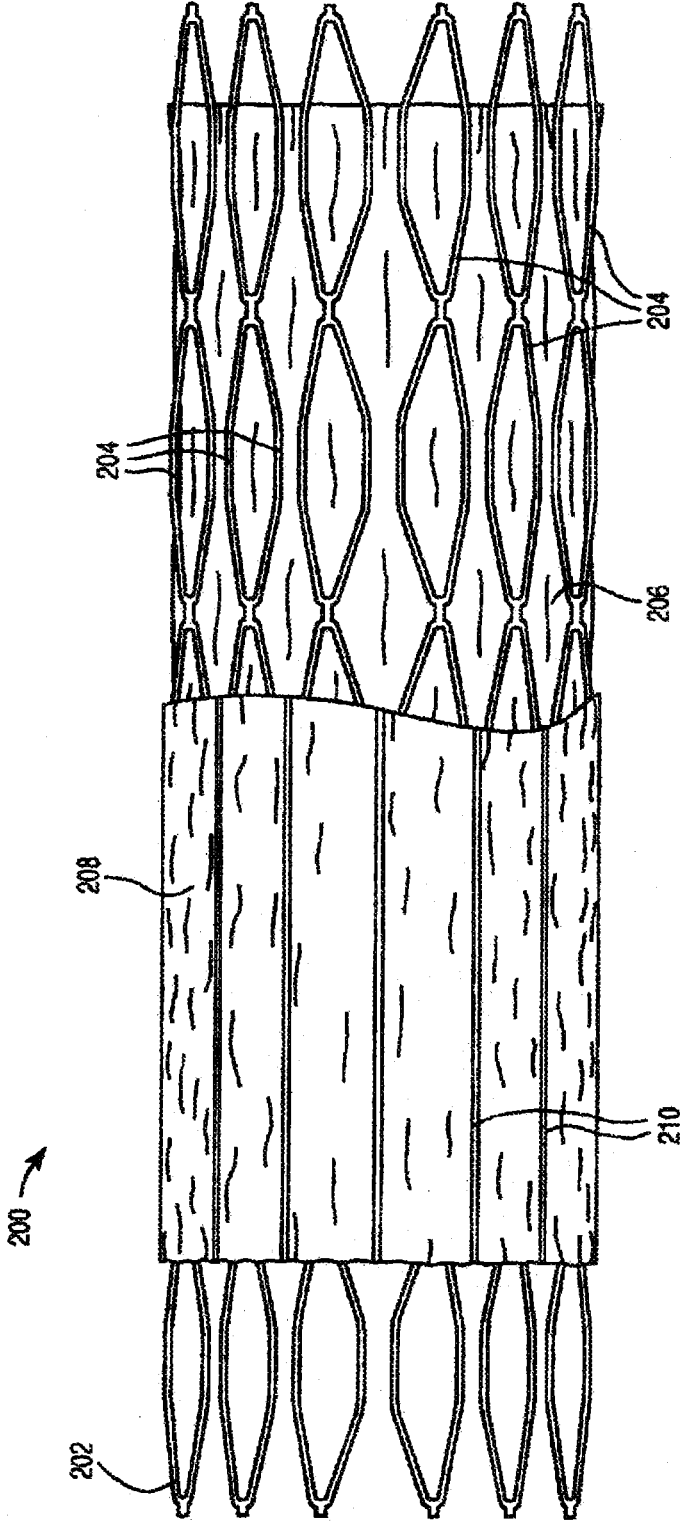

FIG. 1B

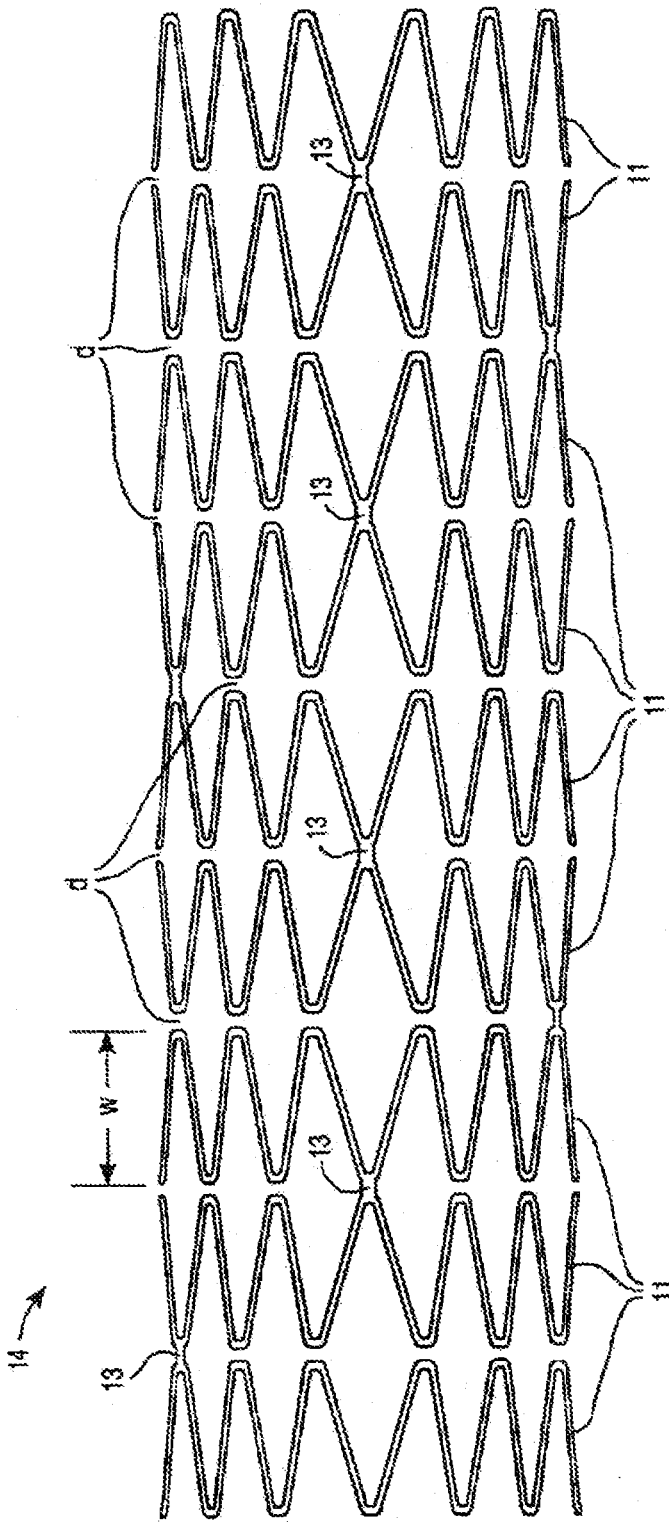
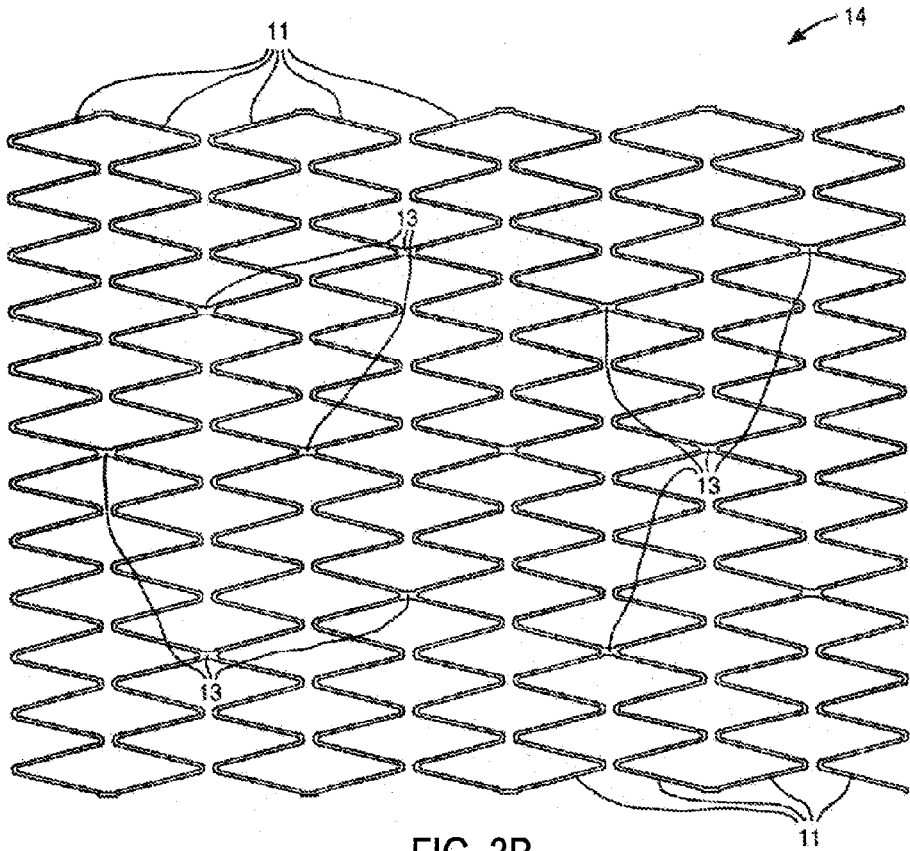
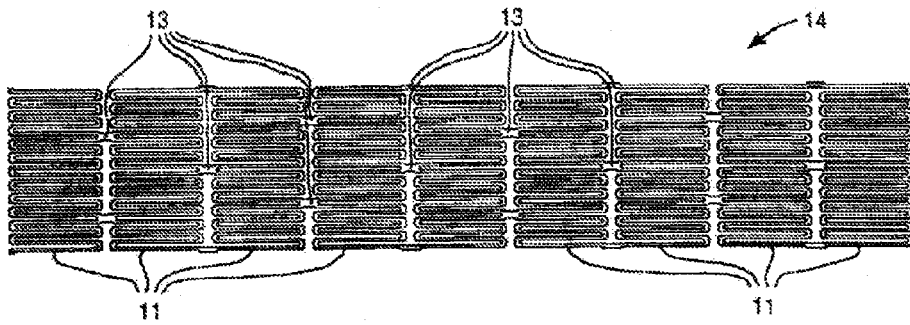

FIG. 2



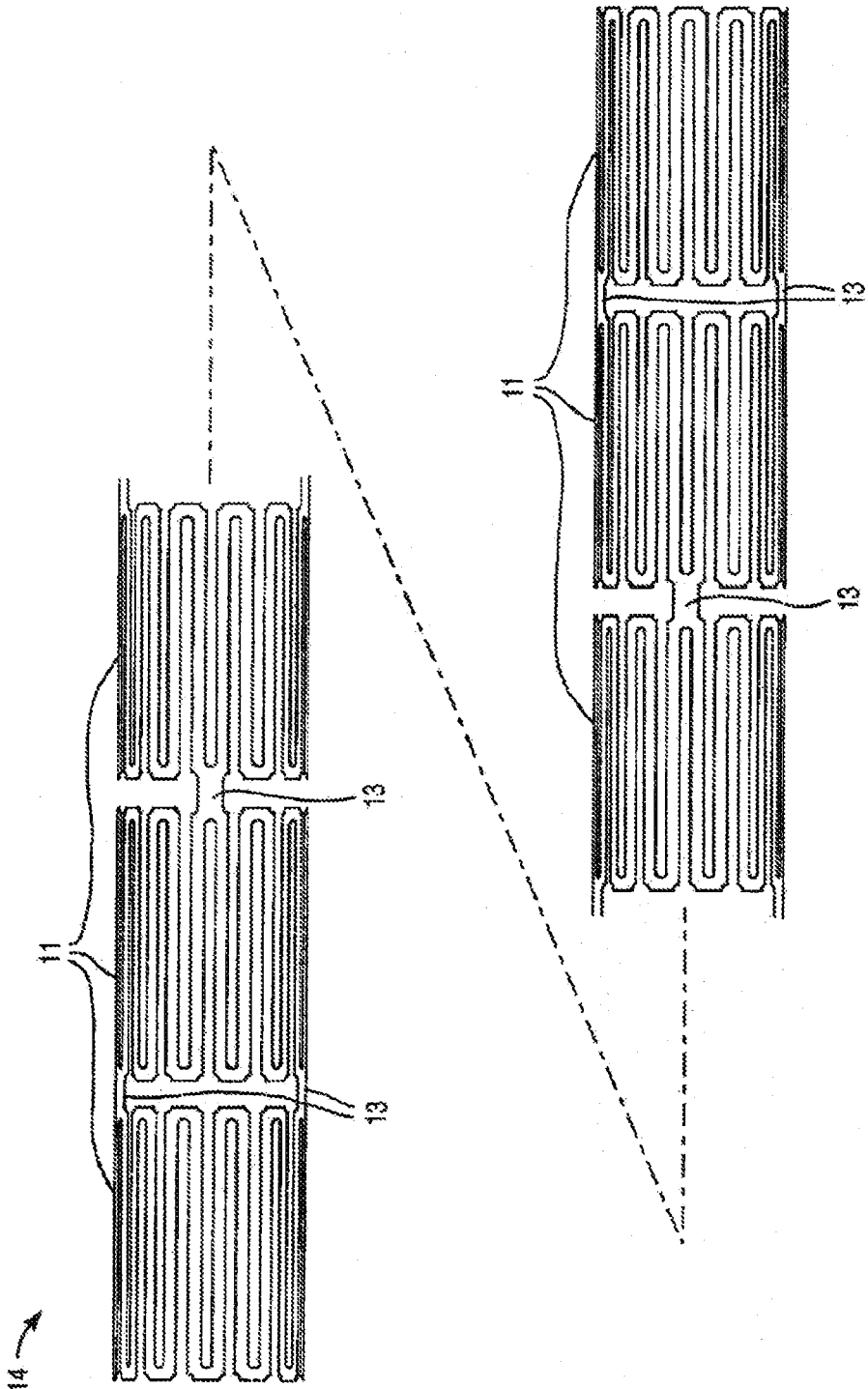

FIG. 4

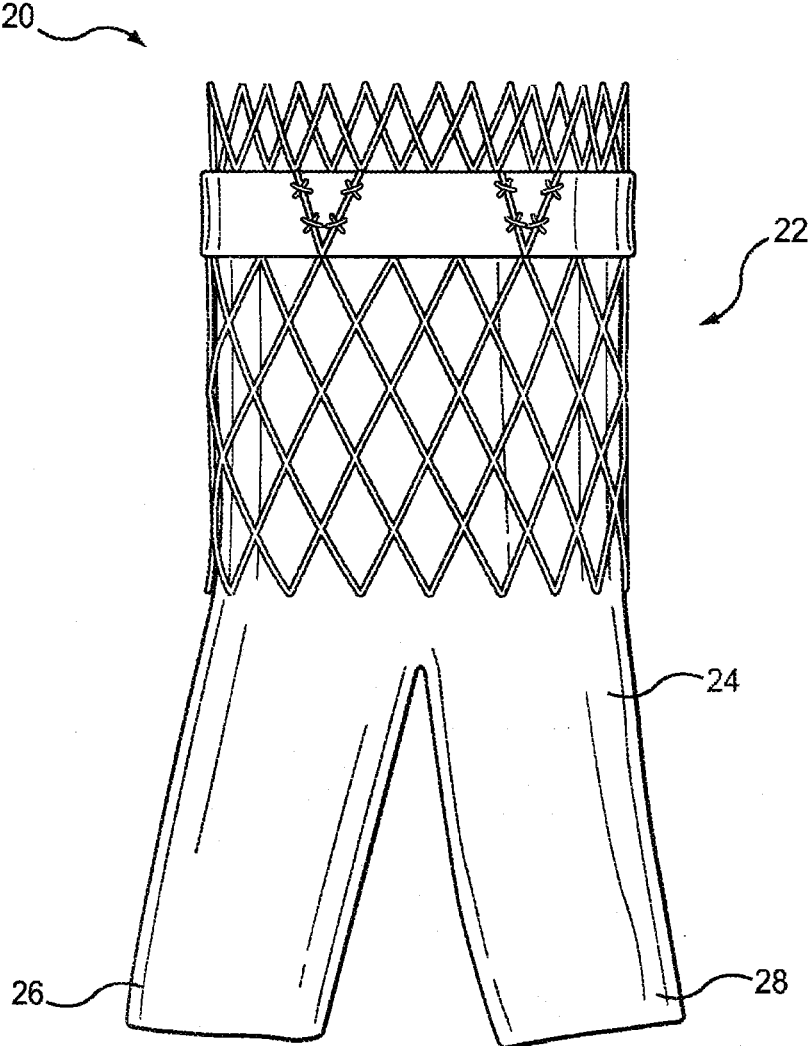

FIG. 5

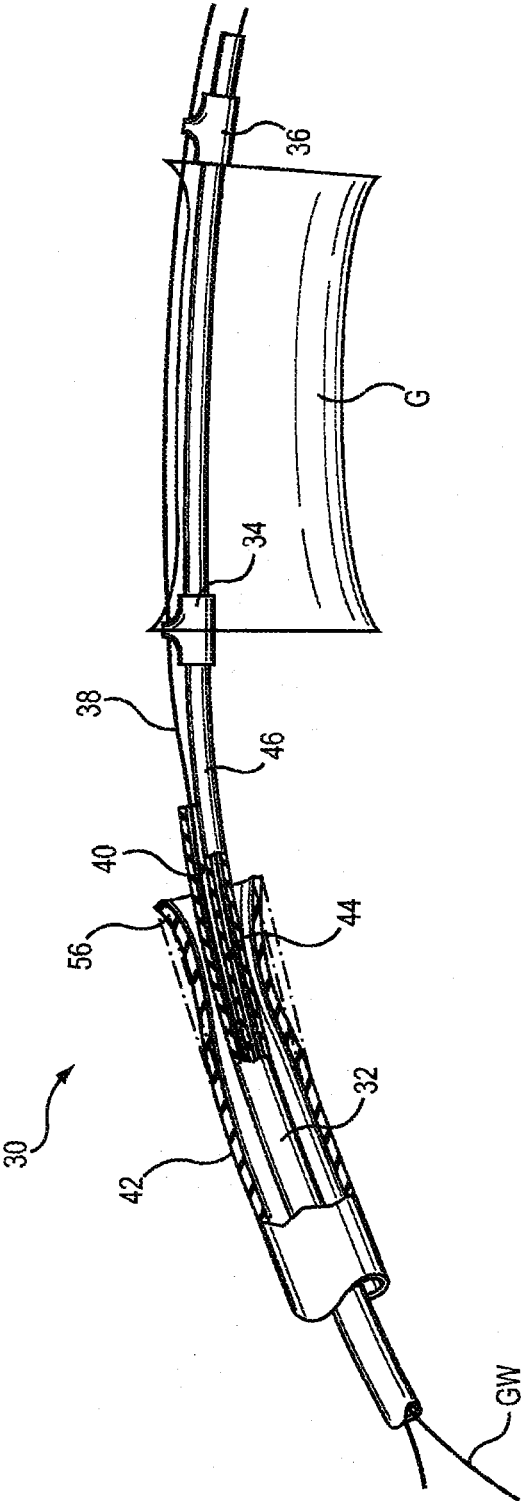

FIG. 6

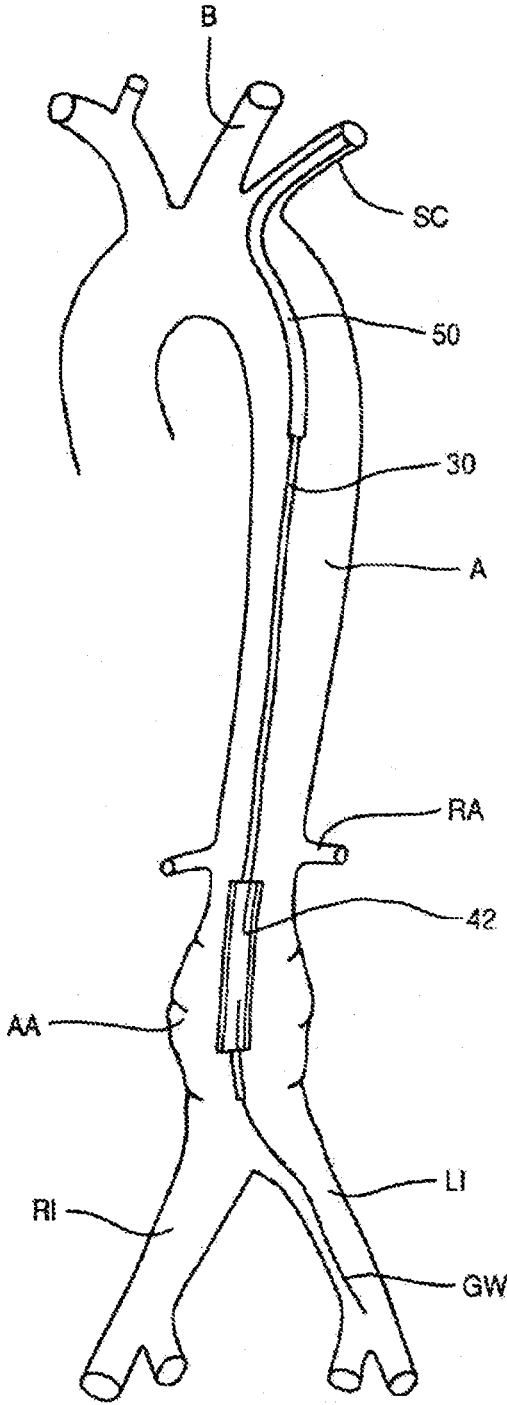

FIG. 7

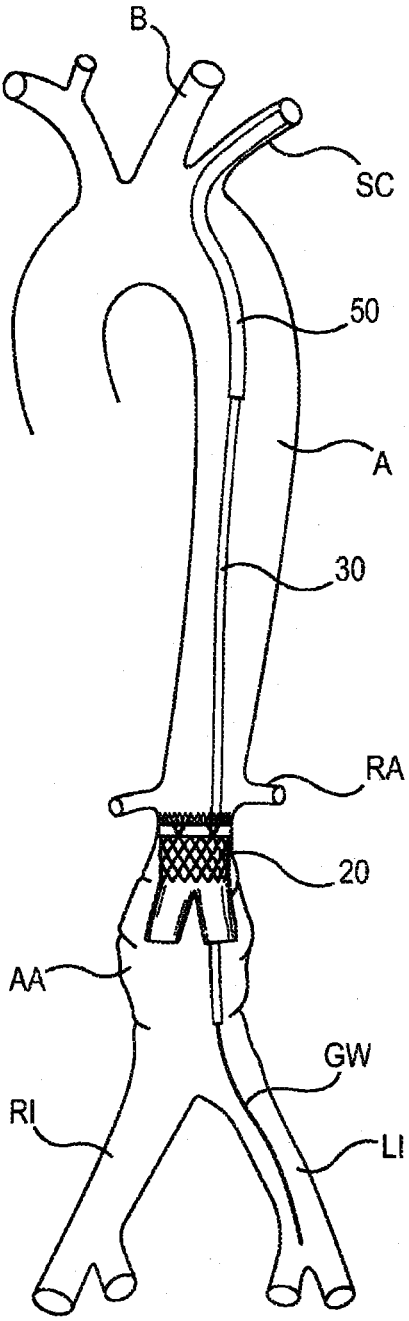

FIG. 8

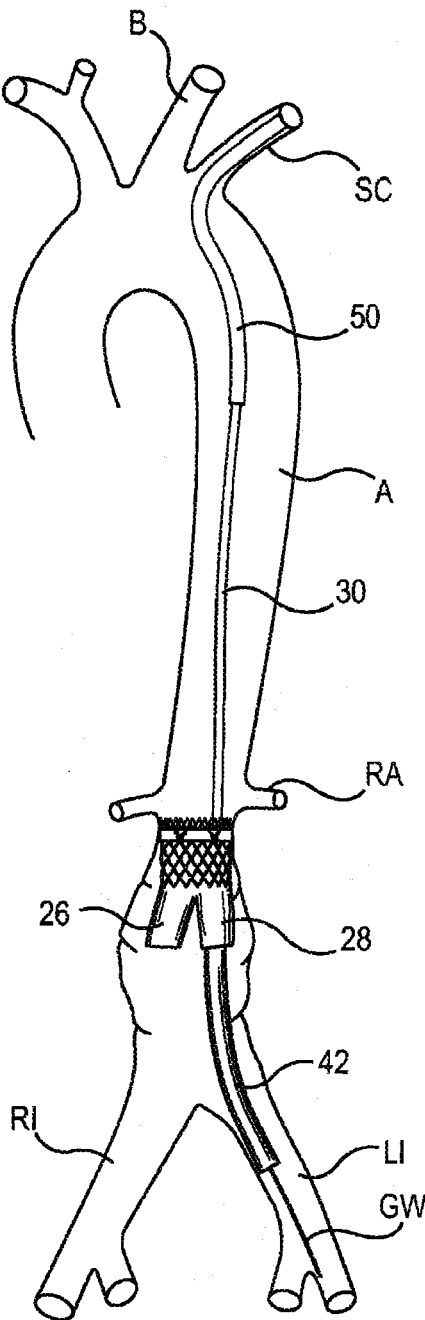

FIG. 9

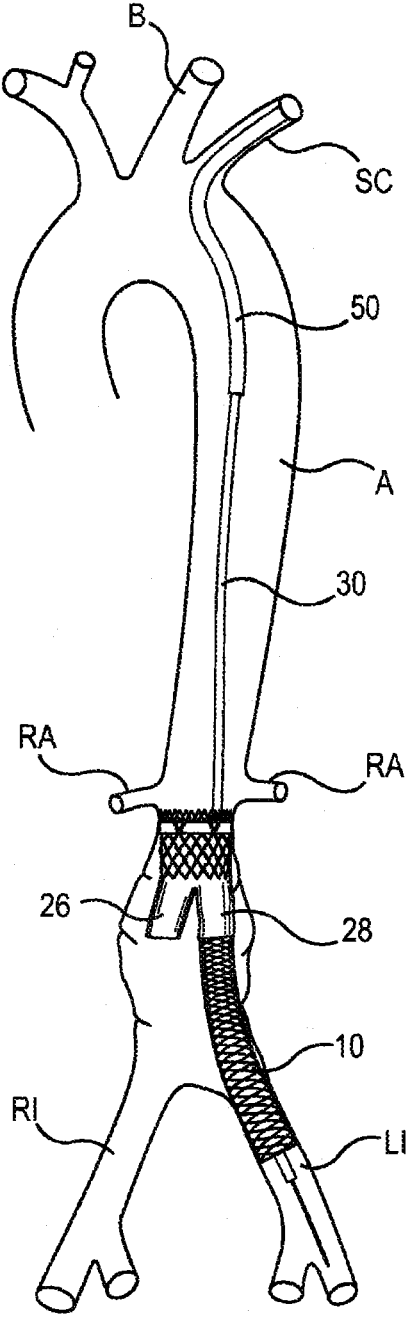

FIG. 10

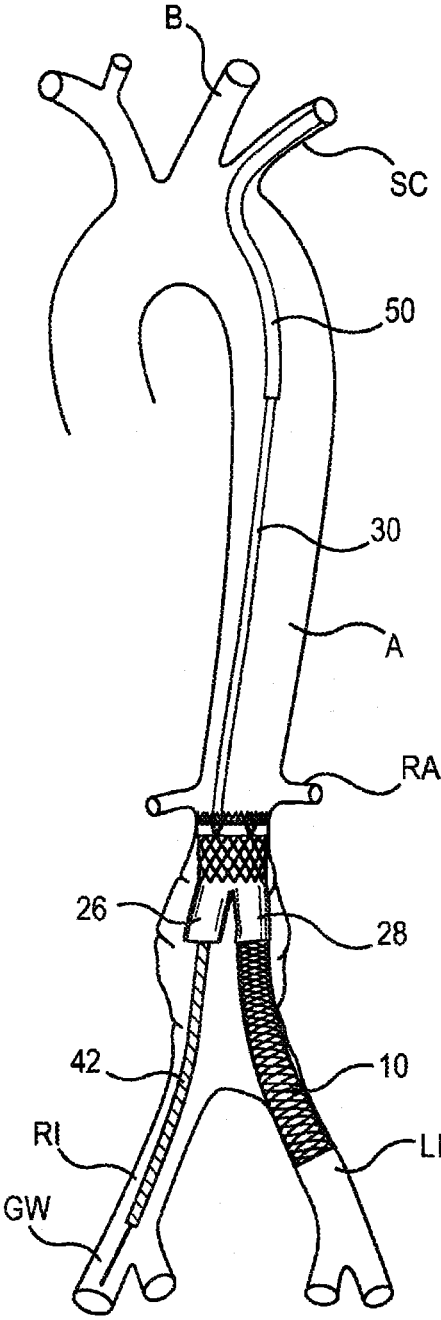

FIG. 11

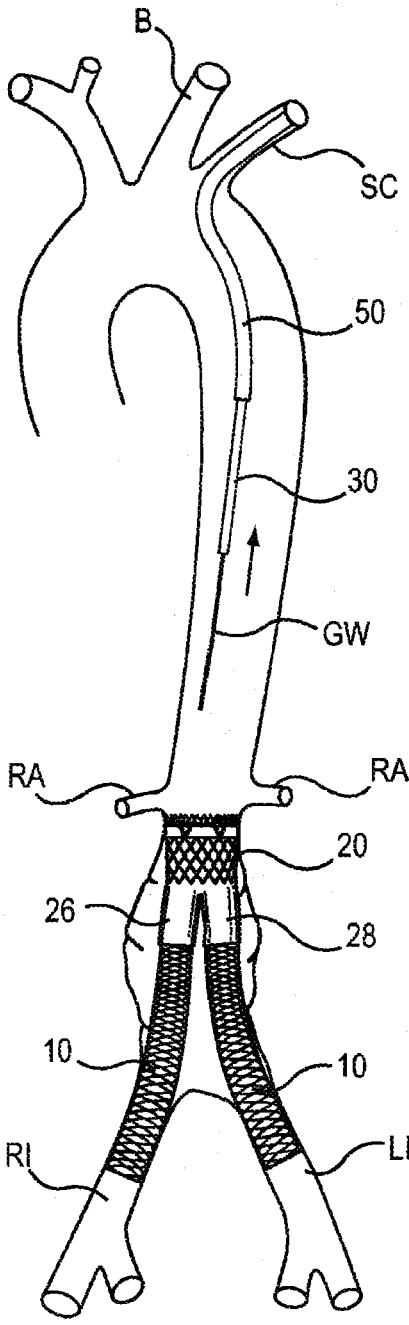

FIG. 12

APPARATUS AND METHODS FOR ENDOLUMINAL GRAFT PLACEMENT

RELATED APPLICATION DATA

[0001] This application is a divisional of co-pending application Ser. No. 13/281,973, filed Oct. 26, 2011, which is a divisional of Ser. No. 08/463,836, filed Jun. 5, 1995, now U.S. Pat. No. 8,206,427, which is a divisional of application Ser. No. 08/255,681, filed Jun. 8, 1994, the entire disclosures of which are expressly incorporated by reference herein.

BACKGROUND OF THE INVENTION

[0002] 1. Field of the Invention

[0003] The present invention relates generally to apparatus and methods for endoluminal placement of grafts, stents, and other structures. More particularly, the present invention relates to a low profile, compressible graft structure and apparatus and methods for vascular placement of such structures for the treatment of abdominal and other aneurysms.

[0004] Vascular aneurysms are the result of abnormal dilation of a blood vessel, usually resulting from disease and/or genetic predisposition which can weaken the arterial wall and allow it to expand. While aneurysms can occur in any blood vessel, most occur in the aorta and peripheral arteries, with the majority of aortic aneurysms occurring in the abdominal aorta, usually beginning below the renal arteries and often extending distally into one or both of the iliac arteries.

[0005] Aortic aneurysms are most commonly treated in open surgical procedures where the diseased vessel segment is bypassed and repaired with an artificial vascular graft. While considered to be an effective surgical technique, particularly considering the alternative of a usually fatal ruptured abdominal aortic aneurysm, conventional vascular graft surgery suffers from a number of disadvantages. The surgical procedure is complex and require experienced surgeons and well equipped surgical facilities. Even with the best surgeons and equipment, however, patients being treated frequently are elderly and weakened from cardiovascular and other diseases, reducing the number of eligible patients. Even for eligible patients prior to rupture, conventional aneurysm repair has a relatively high mortality rate, usually from 3% to 10%. Morbidity related to the conventional surgery includes myocardial infarction, renal failure, impotence, paralysis, and other conditions. Additionally, even with successful surgery, recovery takes several weeks, and often requires a lengthy hospital stay.

[0006] In order to overcome some or all of these drawbacks, endovascular graft placement for the treatment of aneurysms has been proposed. Although very promising, many of the proposed methods and apparatus suffer from other problems. Often times the proposed graft structures will have exposed anchors or frame which can be thrombogenic. It is also difficult to provide graft structures which remain sealed to the blood vessel lumen to prevent the leakage or bypass of blood into the weakened aneurysm, especially when subjected to external deforming forces which result from vessel expansion and contraction as the heart beats. Many vascular graft structures have difficulty in conforming to the internal arterial wall, particularly since the wall can have a highly non-uniform surface as a result of atherosclerosis and calcification and is expanding and con-

tracting with the patient's heartbeat and blood flow. Additionally, many previous vascular graft structures are difficult to position and anchor within the target region of the vessel. **[0007]** For these reasons, it would be desirable to provide improved apparatus and methods for the endovascular placement of intraluminal grafts for treating aneurysms and other conditions. It would be particularly desirable if the graft structures were easy to place in the target region, displayed little or no thrombogenicity, provided a firm seal to the vascular wall to prevent leakage and blood bypass, and were able to conform to uniform and non-uniform blood vessel walls, even while the wall is expanding and contracting with the patient's heartbeat.

[0008] 2. Description in the Background Art

[0009] Vascular grafts and devices for their transluminal placement are described in U.S. Pat. Nos. 5,219,355; 5,211,658, 5,104,399; 5,078,726; 4,820,298; 4,787,899; 4,617,932; 4,562,596; 4,577,631; and 4,140,126; and European Patent Publications 508 473; 466 518; and 461 791. Expandable and self-expanding vascular stents are described in U.S. Pat. Nos. 5,147,370; 4,994,071; and 4,776,337; European patent Publications 575 719; 556 850; 540 290; 536 610; and 481 365; and German patent Publication DE 42 19 949. A flexible vascular stent structure having counter wound helical elements, some of which are separated at particular locations to enhance flexibility, is commercially available from Angiomed, Karlsruhe, Germany, as described in a brochure entitled Memotherm Iliaca Stents.

[0010] Catheters for placing vascular stents are described in U.S. Pat. Nos. 5,192,297; 5,092,877; 5,089,005; 5,037,427; 4,969,890; and 4,886,062.

[0011] Vascular grafts intended for open surgical implantation are described in U.S. Pat. Nos. 5,236,447; 5,084,065; 4,842,575; 3,945,052; and 3,657,744; and PCT applications WO 88/00313 and WO 80/02641; and SU 1697787.

[0012] Nickel titanium alloys and their use in medical devices are described in U.S. Pat. Nos. 4,665,906 and 4,505,767.

SUMMARY OF THE INVENTION

[0013] The present invention comprises apparatus and methods for the endoluminal placement of intraluminal grafts for the treatment of disease conditions, particularly aneurysms. The intraluminal grafts comprise a radially compressible, perforate tubular frame having a proximal end, a distal end, and an axial lumen between said ends. An interior liner, typically a fabric, polymeric sheet, membrane, or the like, covers all or most of the surface of the lumen of the tubular frame, extending from a near-proximal location to a near-distal location. The liner is attached to the frame at at least one end, as well as at a plurality of locations between said ends. Optionally, a second liner may be provided over at least a portion of the exterior of the frame to cover both sides of the frame. Such exterior coverage provides a circumferential seal against the inner wall of the blood vessel lumen in order to inhibit leakage of blood flow between the graft and the luminal wall into the aneurysm or stenosis which is being treated.

[0014] The grafts of the present invention will find particular use in the treatment of vascular conditions, such as abdominal and other aneurysms, vascular stenoses, and other conditions which require creation of an artificial vessel lumen. For the treatment of vascular stenoses, the graft may serve as a stent to maintain vessel patency in a manner

similar to that described in the above-described U.S. and foreign patent documents relating to stents. Other intraluminal uses of the devices and methods of the present invention include stenting of the ureter, urethra, biliary tract, and the like. The devices and methods may also be used for the creation of temporary or long term lumens, such as the formation of a fistula.

[0015] Such graft structures provide a number of advantages over previously proposed designs, particularly for vascular uses. By covering the lumen of the tubular frame, thrombogenicity of the graft resulting from exposed frame elements is greatly reduced or eliminated. Such reduction of thrombogenicity is achieved while maintaining the benefits of having a frame structure extending over the graft. Such an external frame helps anchor the graft in place and maintain patency and evenness of the graft lumen, both of which are advantages over graft structures which are anchored and supported only at each end. The vascular grafts of the present invention are also self-expanding and easy to place. The self-expanding nature of the frame also counteracts external deforming forces that may result from the continuous physiologic expansion and contraction of the blood vessel lumen. Moreover, the lack of cleats, tines, or other penetrating elements on the graft allows the graft to more closely conform to the surrounding vessel wall and facilitates retrieval and/or repositioning of the graft, as will be described in more detail hereinafter. Additionally, the resilient tubular frame structure permits the graft to conform to even irregular regions of the blood vessel wall as the wall is expanding and contracting as a result of the pumping of the patient's heart.

[0016] The tubular frame preferably comprises a plurality of radially compressible band or ring structures, each of which have a relaxed (i.e., non-compressed) diameter which is greater than the diameter of the blood vessel to be treated. Adjacent compressible band members may be independent of each other or may be joined at one or more locations therebetween. If joined, the bands are preferably joined at only two diametrically opposed points to enhance flexibility of the frame over its length. Independent band members will be held together by their attachment to the interior and/or exterior, liner(s).

[0017] Alternatively, the tubular frame may comprise a plurality of laterally compressible axial members, with adjacent axial members preferably not being directly connected to each other. The axial members will usually comprise a multiplicity of repeating structural units, e.g., diamond-shaped elements, which are axially connected. The axial members will be attached to the inner liner, either by stitching or by capturing the axial members in pockets formed between the inner liner and an outer liner disposed over the frame. The pockets may be formed by attaching the inner and outer liners to each other along axial lines between adjacent axial members.

[0018] The present invention also provides methods and systems for the in situ placement of bifurcated grafts for the treatment of aorto-iliac segments and other bifurcated lumens. The system comprises a bifurcated base structure including a proximal anchor, typically a self-expanding frame, which defines a common flow lumen and a pair of connector legs that establish divergent flow lumens from the common flow lumen. The system also includes a first tubular graft which can be anchored within first of the connector legs to form a continuous extension of the first divergent

flow lumen and a second tubular graft which can be anchored within a second of the connector legs to form a continuous extension of the second divergent flow lumen. The method of placement comprises first introducing the bifurcated base structure so that the anchor section is positioned within a primary vessel, i.e., the aorta, below the renal arteries. After the bifurcated base structure is anchored, the first tubular graft is introduced into the first connector leg and anchored between said leg and the first branch artery, e.g., the right iliac. The second tubular graft is then inserted into the second connector section and anchored between the second connector and the second branch artery. By properly selecting the dimensions of the bifurcated base structure, the first tubular graft, and the second tubular graft, the resulting bifurcated graft structure can have dimensions which are specifically matched to the vessel dimensions being treated. Preferably, the bifurcated base structure, first tubular graft, and second tubular graft, will be formed from radially compressible perforate tubular frames having interior and/or exterior liners, generally as described above for the preferred vascular graft of the present invention. The radially compressible perforate tubular frame on the base structure, however, will terminate above the region where the connector legs diverge. The connector legs below the divergent region will be reinforced by placement and expansion of the tubular graft structures therein.

[0019] The present invention further provides a delivery catheter for endovascular placement of radially compressible grafts or stents, such as the vascular grafts and bifurcated base structures described above. The catheter comprises an elongate shaft having a proximal end and a distal end. Preferably, a retaining structure is provided near the distal end of the shaft for holding the graft or the stent on the shaft until such a time that the graft or stent is positively released, e.g., by withdrawing a pull wire which extends through locking stays on either side of the graft or stent. The delivery catheter further comprises a sheath slidably mounted over the shaft. The sheath is initially disposed to cover and restrain the radially compressed graft or stent while the catheter is being intervascularly introduced to a desired target location. The sheath may then be withdrawn, releasing the radially compressed graft or stent to occupy and anchor within the vasculature or other body lumen. Preferably, the graft or stent will remain fixed to the shaft even while the sheath is being withdrawn so that the physician can recapture the graft by advancing the sheath back over its exterior. Only after the graft or stent is fully expanded at the target location within the vessel lumen is the graft or stent finally released. Preferably, the sheath will have a flared or outwardly tapered distal end to facilitate both release and recapture of the graft or stent by axial translation of the sheath. The flared end may be fixed or deployable, i.e., selectively shiftable between a flared and a non-flared configuration. Preferably, the flared end will be deployable so that the sheath may be introduced with the distal end in its non-flared configuration to minimize its profile. After properly positioning the sheath, the distal end may be opened to assume its tapered configuration.

BRIEF DESCRIPTION OF THE DRAWINGS

[0020] FIG. 1 is a side view of a vascular graft constructed in accordance with the principles of the present invention.

[0021] FIG. 1A is a side view of a first alternate embodiment of a vascular graft constructed in accordance with the principles of the present invention.

[0022] FIG. 1B is a side view of a second alternate embodiment of a vascular graft constructed in accordance with the principles of the present invention.

[0023] FIG. 2 is a side view of a radially compressible perforate tubular frame of a type which may be used in a vascular graft of FIG. 1.

[0024] FIGS. 3A and 3B are a schematic illustrations showing the joining pattern of the radially compressible band members of the tubular frame of FIG. 2.

[0025] FIG. 4 illustrates a structure which has been etched from a tube and which may be subsequently expanded to form the tubular frame of FIG. 2.

[0026] FIG. 5 illustrates a bifurcated base structure which is part of a system for forming a bifurcated graft in situ.

[0027] FIG. 6 illustrates the distal end of a graft and stent placement catheter constructed in accordance with the principles of the present invention.

[0028] FIG. 7-12 illustrate placement of a bifurcated aortic graft using the bifurcated graft placement system of the present invention.

DESCRIPTION OF THE SPECIFIC EMBODIMENT

[0029] The present invention provides apparatus and methods for the transluminal placement of graft structures, particularly within the vascular system for treatment of aneurysms and other vascular conditions, but also in other body lumens, such as ureter, urethra, biliary tract, gastrointestinal tract, and the like, for the treatment of other conditions which benefit from the introduction of a reinforcing or protective structure in the lumen. The apparatus and methods can also find use in the creation of artificial lumens through solid tissue and structures, such as the placement of a TE fistula via an endoscope. The vascular grafts will be placed endovascularly. As used herein, "endovascularly" will mean placement by percutaneous or cutdown transluminal procedures using a catheter over a guidewire under fluoroscopic guidance. The catheters and guidewires may be introduced through conventional access sites to the vascular system, such as through the brachial and subclavian arteries for access to the aorta and through the femoral arteries for access to the aorta or to peripheral and branch blood vessels.

[0030] A vascular graft according to the present invention will comprise a radially compressible perforate tubular frame and an inner or interior liner attached within a central lumen defined by the frame and optionally a second or outer liner formed over the exterior of the frame. The radially compressible frame can take a variety of forms, usually comprising or consisting of a plurality of independent or interconnected structural elements, such as rings, bands, helical elements, serpentine elements, axial struts, parallel bars, and the like, that can be compressed from a relaxed, large diameter configuration to a small diameter configuration to facilitate introduction, as discussed below. It is necessary, of course, that the liner(s) remain attached to the frame both in its radially compressed configuration and in its expanded, relaxed configuration.

[0031] A preferred configuration for the tubular frame comprises a plurality of radially compressible band members, where adjacent band members are joined to each other at only two diametrically opposed points in order to enhance

flexibility. In a particularly preferred aspect, the diametrically opposed attachment points are rotationally staggered in order to provide flexibility in more than one direction. A preferred method for forming such a tubular frame is described in more detail hereinafter. In another preferred configuration, at least some of the bands of the frame are independent, i.e., are not directly connected to each other. Instead, the bands are connected only to the liner(s) which maintain the axial integrity of the graft. Preferably, the independent bands are stitched or sealed between interior and exterior liners, as will be described in more detail below. Other suitable frame structures are described in the patent literature.

[0032] In an alternate configuration, the perforate tubular frame comprises a plurality of laterally compressible axial members which are attached directly, e.g., by stitching, or indirectly, e.g., by lamination, to the inner liner. The axial members may be a multiplicity of repeating structural elements, such as diamonds, or could be formed from two or more overlapping elements. By positioning the axial members in pockets formed between an inner liner and an outer liner, the axial elements will be able to flex independently while providing the desired radial compressibility and self-expansion characteristics for the graft.

[0033] The dimensions of the tubular graft will depend on the intended use. Typically, the graft will have a length in the range from about 50 mm to 500 mm, preferably from about 80 mm to 200 mm for vascular applications. The relaxed diameter will usually be in the range from about 4 mm to 45 mm, preferably being in the range from about 5 mm to 25 mm for vascular applications. The graft will be radially compressible to a diameter in the range from 3 mm to 9 mm, preferably from 4 mm to 6 mm for vascular applications.

[0034] The liner(s) will be composed of conventional biological graft materials, such as polyesters, polytetrafluoroethylenes (PTFE's), polyurethanes, and the like, usually being in the form of woven fabrics, non-woven fabrics, polymeric sheets, membranes, and the like. A presently preferred, fabric liner material is a plain woven polyester, such as type 56 Dacron® yarn (Dupont, Wilmington, Del.), having a weight of 40 denier, woven at 27 filaments with 178 warp yarns per circumferential inch, and 78 yarns per inch in the fill direction.

[0035] The liner will be attached to the interior lumen of the tubular frame and will cover most or all of the interior surface of the lumen. For example, the liner may be stitched or otherwise secured to the tubular frame along a plurality of circumferentially spaced-apart axial lines. Such attachment permits the liner to fold along a plurality of axial fold lines when the frame is radially compressed. The liner will further be able to open and conform to the luminal wall of the tubular frame as the frame expands. Alternatively, when inner and outer liners are used, the liners may be stitched, heat welded, or ultrasonically welded together to sandwich the tubular frame therebetween. In an exemplary embodiment where a plurality of independent band members are disposed between interior and exterior liners, the liners are secured together along circumferential lines between adjacent band members to form pockets for holding the band members. In a second exemplary embodiment where a plurality of independent axial members are disposed between interior and exterior liners, the liners are secured together along axial lines to form pockets for holding the axial members.

[0036] The liner will preferably be circumferentially sealed against the tubular frame at at least one end, preferably at both ends in the case of straight (non-bifurcated) grafts. It is also preferred in some cases that the distal and proximal end of the perforate tubular frame be exposed, i.e., not covered by the liner material, typically over a length in the range from about 1 mm to 25 mm. Frame which is not covered by the liner permits blood perfusion through the perforations and into branch arteries such as the renal arteries in the case of abdominal aorta grafts, while providing additional area for anchoring the frame against the blood vessel lumen. In an exemplary embodiment, the liner will extend through the frame and over the exterior surface near either or both ends to provide a more effective seal against the adjacent blood vessel wall.

[0037] The radially compressible perforate tubular frame will be composed of a resilient material, usually metal, often times a heat and/or shape memory alloy, such as nickel titanium alloys which are commercially available under the trade name Nitinol®. The frames may also be composed of other highly elastic metals, such as MP-35 N, Elgiloy, 316 L stainless steel, and the like. In the case of Nitinol® and other memory alloys, the phase transition between austenitic and martensitic states may occur between an introduction temperature, e.g., room temperature (approximately 22° C.), and body temperature (37° C.), to minimize stress on the unexpanded frame and enhance radial expansion of the frame from its radially compressed condition. Expansion can also be achieved based on the highly elastic nature of the alloy, rather than true shape recovery based on phase change.

[0038] In some cases, it may be desirable to form a tubular frame having different elastic or other mechanical properties at different regions along its length. For example, it is possible to heat treat different regions of the tubular frame so that some regions possess elastic properties while others become malleable so that they may be deformed by external force. For example, by providing at least one malleable end portion and an elastic (radially compressible) middle portion, the graft can be firmly expanded and implanted by internal balloon expansion force (to anchor the end(s) in the inner wall of the blood vessel) while the middle will remain open due to the elastic nature of the tubular member. Malleable end portions are a particular advantage since they can be expanded with a sufficient force, and re-expanded if necessary, to assure a good seal with the blood vessel wall. Alternatively, the malleable ends could be formed from a different material than that of the middle portion of the tubular frame. The use of different materials would be particularly convenient when the frame is formed from a plurality of independent bands, where one or more band members at either or both ends could be formed of a malleable metal. Usually, such malleable end(s) will extend over a distance in the range from 5 mm to 50 mm, preferably from 5 mm to 20 mm.

[0039] Malleable portions or segments can also be formed in other parts of the tubular frame. For example, some circumferentially spaced-apart segments of the tubular frame could be malleable while the remaining circumferential segments would be elastic. The frame would thus remain elastic but have an added malleability to permit expansion by applying an internal expansion force. Such a construction would be advantageous since it would allow the diameter of the graft or stent structure to be expanded if the initial diameter (which resulted entirely from elastic expansion)

were not large enough for any reason. The proportion of elastic material to malleable material in the tubular frame can be selected to provide a desired balance between the extend of initial, elastic opening and the availability of additional, malleable opening. Such construction can be achieved by selective heat treatment of portions of a frame composed of a single alloy material, e.g. nickel titanium alloy, or by forming circumferential segments of the frame from different materials having different elastic/malleable properties. In particular, individual laterally compressible axial members **204** (as described in connection with FIG. 1B) could be formed from materials having different elastic/malleable properties.

[0040] Referring now to FIGS. 1-4, an exemplary graft structure **10** will be described. The graft structure **10** includes a fabric liner **12** and a radially compressible perforate tubular frame **14**. For convenience, the frame **14** is illustrated by itself in FIG. 2. The frame is illustrated in its expanded (relaxed) configuration in each of these figures, but may be radially compressed by applying a radially inward compressive force, usually by placing the graft **10** in an outer sheath, as will be described in more detail herein-after.

[0041] The tubular frame **14** comprises a plurality of radially compressible band members **11**, each of which comprises a zig-zag or z-shaped element which forms a continuous circular ring. Each band member **11** will typically have a width *w* in the range from 2 mm to 15 mm, and the tubular frame will comprise from 1 to 30 individual band members. Adjacent band members **11** are preferably spaced-apart from each other by a short distance *d* and are joined by bridge elements **13**. Flexibility is enhanced by providing only two diametrically opposed bridge elements **13** between each adjacent pair of band members **11**. As will be described further with reference to FIG. 1A, flexibility can be further enhanced by leaving the band members connected only by the liner.

[0042] Usually, the perforate tubular frame **14** will be left open at each end, e.g., at least a portion of the last band member **11** will remain uncovered by the liner **12**. The liner **12** will be stitched or otherwise secured to the band members **11**, preferably at the junctions or nodes when the element reverses direction to form the z-pattern (although the stitching should not cross over between the band members in a way that would restrict flexibility). The liner **12** will usually pass outward from the inner lumen of the tubular frame **14** to the exterior of the frame through the gap between adjacent band members, as illustrated in FIG. 1. The portion of liner **12** on the exterior of the tubular frame **14** helps seal the end(s) of the graft **10** against the wall of the blood vessel or other body lumen in which it is disposed.

[0043] The joining pattern of adjacent band members **11** is best illustrated in FIGS. 3A and 3B. FIG. 3A illustrates the tubular frame **14** as it would look if unrolled onto a flat surface. FIG. 3B is similar to FIG. 3A, except that the band members are expanded. The expansion is shown at 30°, but will frequently extend up to 60° or higher in use.

[0044] A preferred method for forming the tubular frame **14** in the present invention may be described with reference to FIG. 4. A tube of the desired elastic material, such as nickel titanium alloy having a phase transformation temperature significantly below 37° C., preferably between 30° C. and 32° C., is obtained. The tube will have dimensions roughly equal to the desired dimensions of the frame when

radially compressed. The tube may be drawn, rolled, or otherwise treated to achieve the desired wall thickness, diameter, and the like. Suitable wall thicknesses are in the range of about 0.1 mm to 0.5 mm. A pattern of axial slots is then formed in the tube, as illustrated in FIG. 4. The slots may be formed by electrical discharge machining (EDM), photochemical etching, laser cutting, machining or other conventional techniques. After the slots have been formed, the tube is mechanically expanded to its desired final (relaxed) diameter and heat treated at a suitable temperature to set the tube in the desired expanded state. Sharp edges are removed by conventional techniques, such as deburring, abrasive extrusion, or the like. The result of the expansion is the tubular frame illustrated in FIGS. 1 and 2.

[0045] Preferably, each end of the liner 12 will be circumferentially sealed at or near the distal and proximal ends of the tubular graft. As illustrated in FIG. 1A, this can be achieved by folding over the end of the liner 12 onto the external surface of the graft 10. Conveniently, this can be done through the gaps which are present between adjacent band members 14. Where the junctions 13 remain, the liner 12 can be carefully stitched onto the underlying surface of the frame, as shown at 18 in FIG. 1A. Other techniques for circumferentially sealing the liner include heat or ultrasonic welding of the liner, laminating an outer gasket, sewing an outer reinforcement member, or the like.

[0046] Referring now to FIG. 1A, an alternative embodiment 100 of a vascular graft constructed in accordance with the principles of the present invention will be described. The graft 100 comprises a perforate tubular frame 102 which includes a plurality of independent (non-connected) band members 104 separated from each other by gaps 106. The perforate tubular frame 102 is similar in construction to frame 14 of graft 10, except that adjacent band members 104 are not directly connected to each other. Band members 104 will be connected only by an inner liner 108 and an outer liner 110, where the inner and outer liners together encase or sandwich the otherwise free-floating band members 104. In order to secure the band members 104 in place, and secure the liners to the perforate tubular frame 102, the inner and outer liners are joined together along circumferential lines 112, preferably located in the gaps 106 between adjacent band members 104. The liners may be joined together by stitching, heat welding, ultrasonic welding, or the like. In the exemplary embodiment, the liners 108 and 110 are formed from polymeric sheet material and are joined together by ultrasonic welding. The band members 104 at each end of the graft 100 will have to be further secured to the liners 108 and 110. For example, they could be stitched, welded, or otherwise joined to the liners to hold them in place. The dimensions, materials, and other aspects of the graft 100 will be generally the same as those described previously for graft 10.

[0047] Referring now to FIG. 1B, a second alternative embodiment 200 of the vascular graft of the present invention is illustrated. The graft 200 comprises a perforate tubular frame 202 including a plurality of laterally compressible axial members 204. Each axial member 204 comprises a plurality of diamond-shaped structural elements which are connected to each other in a linear fashion. It will be appreciated that each diamond-shaped structural element is laterally compressible so that the frame 202 as a whole may be radially compressed from a reduced-diameter configuration to an expanded-diameter configuration. As illus-

trated in FIG. 1B, the frame is in a partially compressed configuration. The axial members 202 will be captured between an inner liner 206 and an outer liner 208. The inner liner 206 and outer liner 208 will be secured to each other along a plurality of axial lines 210 disposed between adjacent axial members 204. In this way, each axial member 204 will be captured within a pocket formed between the inner liner 206 and outer liner 208. As with previous embodiments, the ends of the frame may extend beyond the liners to provide for improved anchoring and perfusion on either side of the graft.

[0048] Referring now to FIG. 5, a bifurcated base structure for forming a bifurcated graft in combination with a pair of the vascular grafts 10 just discussed will be described. The bifurcated base structure 20 comprises an anchor segment 22, which typically will be a radially compressible perforate frame having a structure similar or identical to that just discussed. The frame of anchor 22 will typically have a length in the range from about 5 mm to 50 mm, and a diameter in the range from about 5 mm to 30 mm. A liner 24 will be disposed within the frame 22, typically being circumferentially sealed near the upper end of the frame, e.g., being folded over and stitched as described previously. As with the straight graft embodiment of FIGS. 1-4, the proximal end of the liner 24 will preferably be distally spaced-apart from the proximal end of the anchor segment 22, typically by a distance in the range from 1 mm to 25 mm. The fabric 24 defines a common flow lumen at its upper end and a pair of divergent flow lumens at its lower end, one in each leg 26 and 28. The legs 26 and 28 are preferably not covered by the frame of anchor 22. The fabric legs 26 and 28 will each have a diameter in the range from 6 mm to 18 mm and a length in the range from 5 mm to 30 mm. The dimensions of each leg need not be the same.

[0049] Referring now to FIG. 6, a catheter 30 for delivering the vascular graft 10 or bifurcated base structure 20 will be described. The catheter 30 includes a shaft 32 having a pair of axially spaced-apart stays 34 and 36. A pull wire 38 extends through a lumen 40 of shaft 32 and through protrusions on each of the stays 34 and 36. A sheath 42 is slidably disposed over the shaft 32 so that it may be advanced over the stays 34 and 36. Guidewire 34 extends through the shaft 32 and shaft extension 46 to facilitate vascular introduction of the catheter 30. A radially compressible graft G (such as graft 10) is placed over the distal end of the shaft extension 46, generally being aligned between the stays 34 and 36. The pull wire 38 is then advanced through the stays 34 and 36 so that it passes through each end of the graft G to maintain the graft in place until the pull wire is withdrawn. While the pull wire 38 remains in place, the sheath 42 may be axially advanced over the graft to radially compress the graft into its desired low profile diameter. The sheath 42 includes a flared (i.e., outwardly tapered) distal end 46 to facilitate advancing the sheath over the graft, in particular so that the graft may be recaptured when it is partially deployed, as described hereinafter. The outward taper may be permanently fixed in the body of the sheath, but will preferably be selectively deployable between the tapered configuration and a non-tapered or straight configuration (shown in broken line) to facilitate introduction of the sheath through the vasculature or other body lumen. A variety of suitable mechanisms for selectively expanding the distal end of the sheath are known in the art, such as pull wires and the like. The sheath 42 will

be introduced through the vasculature through a conventional introducer sleeve having a proximal hemostasis valve.

[0050] The catheter **30** may be modified to provide alternate delivery techniques for the graft **G**. For example, the catheter **30** may include a balloon at or near its distal end for use with grafts having malleable portions which need to be expanded. The catheter **30** might also include bumpers or other means for aligning the graft on the shaft **46** while the sheath **42** is being retracted. A variety of other catheter constructions and techniques for delivering the radially-compressible graft and stent structures of the present invention.

[0051] Referring now to FIGS. **7-12**, placement of a bifurcated graft structure in an abdominal aortic aneurysm **AA** of a patient will be described. Initially, the delivery catheter **30** is introduced through an introducer sleeve **50** via an antegrade approach (e.g. the subclavian artery **SC**), as illustrated in FIG. **7**. The bifurcated base structure is initially maintained within sheath **42** so that it remains radially compressed. After the compressed base structure **20** is properly positioned, the sheath **42** will be withdrawn, allowing the base structure **20** to expand in place, as illustrated in FIG. **8**. The catheter **30** may then be withdrawn, leaving the guidewire **GW** in place. A vascular graft **10** is then mounted on the catheter **30** and reintroduced so that the compressed vascular graft lies within the fabric liner leg **28** while covered with sheath **42**, as illustrated in FIG. **9**. The sheath **42** is then withdrawn so that the vascular graft **10** will expand both within the leg **28** and the left iliac **LI**, as illustrated in FIG. **10**. The catheter **30** is then withdrawn, and the guidewire is transferred from the left iliac **LI** to the right iliac **RI**. Alternatively, a separate guidewire could be introduced. Catheter **30** is then reintroduced over the guidewire with sheath **42** covering a second vascular graft **10** and advanced into the right iliac, as illustrated in FIG. **11**. The sheath **42** is then withdrawn, allowing the second vascular graft **10** to expand within both the right iliac **RI** and the second leg **26** of the fabric liner. The completed bifurcated graft structure is then in place, as illustrated in FIG. **12**, and the guidewire **GW**, catheter **30**, and introducer sheath **50** may then be withdrawn.

[0052] Femoral access and retrograde placement of the graft structures of the present invention will be possible although such an approach is not presently preferred.

[0053] Positioning and repositioning of the stent-graft structure of the present invention can be facilitated by use of an ultrasonic imaging catheter or guidewire, such as the guidewires described in U.S. Pat. No. 5,095,911 and PCT WO 93/16642. Such ultrasonic guidewires can be used in place of the conventional guidewire **30** illustrated in FIGS. **7-12**, typically being sealed by a hemostasis valve at the proximal end of the delivery catheter **30**. Locking means, clamps, markings, and the like, may be provided on either or both of the delivery catheter **30** and the imaging guidewire to assure proper positioning of the ultrasonic transducer within the stent-graft structure during the placement procedure. The aneurysm or other anomaly being treated can then be precisely located prior to release of the stent-graft **10**. After partial placement, proper location of the stent-graft **10** can be confirmed with the ultrasonic imaging device. If the position is not correct, the stent-graft **10** can be drawn back into the sheath **42**, and the stent-graft be repositioned prior to complete release. The use of an ultrasonic imaging

guidewire is advantageous since there is no need to exchange the guidewire for a separate ultrasonic imaging catheter.

[0054] Although the foregoing invention has been described in some detail by way of illustration and example, for purposes of clarity of understanding, it will be obvious that certain changes and modifications may be practiced within the scope of the appended claims.

1. A method for introducing a vascular graft into a primary artery which divides into first and second branch arteries, said method comprising:

introducing and deploying a bifurcated structure including an anchor section and first and second connector sections so that the anchor section is disposed within the primary artery and the first and second connector sections extend toward the first and second branch arteries and thereafter;

introducing a first tubular graft into the first connector section and anchoring said first tubular graft to extend between the first connector section and the first branch artery to form a first continuous flow path from the primary artery to the first branch artery; and

introducing a second tubular graft into the second connector section and anchoring said second tubular graft to extend between the second connector section and the second branch artery to form a second continuous flow path from the primary artery to the second branch artery.

2. A method as in claim **1**, wherein the primary artery is an aorta, the first branch artery is a right iliac, and the second branch artery is a left iliac.

3. A method as in claim **1**, wherein the anchor section of the bifurcated structure is radially compressed while being introduced.

4. A method as in claim **3**, wherein the anchor section is composed of a resilient material, said method further comprising releasing the radially compressed anchor section at a target location with the primary artery.

5. A method as in claim **1**, wherein the bifurcated structure is introduced through the primary artery in an antegrade direction.

6. A method as in claim **1**, wherein the bifurcated structure is introduced through a branch artery in a retrograde direction.

7. A method as in claim **1**, wherein the first tubular graft is radially compressed while being introduced.

8. A method as in claim **7**, wherein the first tubular graft is composed of a resilient material, said method further comprising releasing the radially compressed graft to anchor simultaneously within the first connector and the first branch artery.

9. A method as in claim **1**, wherein the first tubular graft is introduced through the primary artery in an antegrade direction.

10. A method as in claim **1**, wherein the first tubular graft is introduced through a branch artery in a retrograde direction.

11. A method as in claim **1**, wherein the second tubular graft is radially compressed while being introduced.

12. A method as in claim **11**, wherein the second tubular graft is composed of a resilient material, said method further comprising releasing the radially compressed graft to anchor simultaneously within the second connector and the second branch artery.

13. A method as in claim 1, wherein the second tubular graft is introduced through the primary artery in an antegrade direction.

14. A method as in claim 1, wherein the second tubular graft is introduced through a branch artery in a retrograde direction.

15. A method for treating an aneurysm by introducing a vascular graft into a primary artery which branches into first and second branch arteries, said method comprising:

introducing into a patient's vasculature an anchor section and first tubular graft of the vascular graft so that the anchor section is disposed within the primary artery and the first tubular graft is at least partially disposed within the first branch artery to form a first continuous flow path from the primary artery to the first branch artery; and

securing a second tubular graft to the anchor section via a connector leg of the anchor section to form a second continuous flow path from the primary artery to the second branch artery, wherein each of the grafts comprises a tubular frame and a liner.

16. A method as in claim 15, wherein the primary artery is an aorta, the first branch artery is a right iliac, and the second branch artery is a left iliac.

17. A method as in claim 15, wherein the anchor section and first tubular graft of the vascular graft are radially compressed while being introduced.

18. A method as in claim 17, wherein the anchor section and first tubular graft of the vascular graft are resilient, said introducing step comprising releasing the radially compressed anchor section and first tubular graft at a target location with the vasculature.

19. A method as in claim 18, wherein the anchor section and first tubular graft of the vascular graft are introduced through the primary artery in an antegrade direction.

20. A method as in claim 18, wherein the anchor section and first tubular graft of the vascular graft are introduced through a branch artery in a retrograde direction.

21. A method as in claim 18, wherein the second tubular graft is radially compressed while being introduced.

22. A method as in claim 21, wherein the second tubular graft is resilient, said method further comprising releasing the radially compressed second tubular graft to anchor within the connector leg on the anchor section.

23. A method as in claim 22, wherein the second tubular graft is introduced through the primary artery in an antegrade direction.

24. A method as in claim 22, wherein the second tubular graft is introduced through a branch artery in a retrograde direction.

25. A method as in claim 15, wherein the introducing step comprises securing the first tubular graft to the anchor section of the vascular graft after the anchor section has been disposed within the primary artery.

26. A method as in claim 25, wherein the first tubular graft is secured to the anchor section via a second connector leg of the anchor section.

27. A method as in claim 26, wherein the first tubular graft is resilient and wherein the securing of the first tubular graft to the anchor section comprises releasing the first tubular graft from a compressed configuration to expand within the second connector leg and the first branch artery.

28. A method as in claim 27, wherein the second tubular graft is resilient and wherein the securing of the second tubular graft to the anchor section comprises releasing the second tubular graft from a compressed configuration to expand within its respective connector leg and the second branch artery.

29. A method as in claim 25, wherein the primary artery is an aorta, the first branch artery is a right iliac, and the second branch artery is a left iliac.

30. A method as in claim 29, wherein the second tubular graft is resilient and wherein the securing of the second tubular graft to the anchor section comprises releasing the second tubular graft from a compressed configuration to expand within the connector leg and the left iliac.

31. A method as in claim 25, wherein the anchor section of the vascular graft is radially compressed while being introduced.

32. A method as in claim 31, wherein the anchor section is resilient, said introducing step comprising releasing the radially compressed anchor section at a target location with the vasculature.

33. A method as in claim 32, wherein the anchor section of the vascular graft is introduced through the primary artery in an antegrade direction.

34. A method as in claim 32, wherein the anchor section of the vascular graft is introduced through a branch artery in a retrograde direction.

35. A method as in claim 25, wherein the first tubular graft is radially compressed while being introduced.

36. A method as in claim 35, wherein the first tubular graft is resilient, said introducing step comprising releasing the radially compressed first tubular graft to anchor within a second connector leg on the anchor section.

37. A method as in claim 36, wherein the first tubular graft is introduced through the primary artery in an antegrade direction.

38. A method as in claim 36, wherein the first tubular graft is introduced through a branch artery in a retrograde direction.

39. A method as in claim 36, wherein the second tubular graft is radially compressed while being introduced.

40. A method as in claim 39, wherein the second tubular graft is resilient, said method further comprising releasing the radially compressed second tubular graft to anchor simultaneously within the connector leg on the anchor section and the second branch artery.

41. A method as in claim 40, wherein the second tubular graft is introduced through the primary artery in an antegrade direction.

42. A method as in claim 40, wherein the second tubular graft is introduced through a branch artery in a retrograde direction.

* * * * *