

(19)



Europäisches Patentamt
European Patent Office
Office européen des brevets



(11)

EP 0 686 721 B1

(12)

EUROPEAN PATENT SPECIFICATION

(45) Date of publication and mention
of the grant of the patent:
10.05.2000 Bulletin 2000/19

(51) Int. Cl.⁷: **D06F 39/00**

(21) Application number: **94108840.3**

(22) Date of filing: **09.06.1994**

(54) **Method for optimising water utilisation in a washing machine, washing-drying machine or the like during the use thereof**

Verfahren zum Optimieren der Wasserausnutzung in Waschmaschinen

Procédé pour optimiser l'utilisation de l'eau dans les machines à laver

(84) Designated Contracting States:
DE FR GB

(43) Date of publication of application:
13.12.1995 Bulletin 1995/50

(73) Proprietor:
WHIRLPOOL EUROPE B.V.
5507 SK Veldhoven (NL)

(72) Inventors:
• **Paganini, Raffaele,**
c/o Whirlpool Italia s.r.l.
I-21025 Comerio (IT)
• **Turetta, Daniele,**
c/o Whirlpool Italia s.r.l.
I-21025 Comerio (IT)

• **Civanelli, Claudio,**
c/o Whirlpool Italia s.r.l.
I-21025 Comerio (IT)

(74) Representative:
Guerci, Alessandro
Whirlpool Europe S.r.l.
Patent Department
Viale G. Borghi 27
21025 Comerio (VA) (IT)

(56) References cited:
EP-A- 0 441 984 **EP-A- 0 526 860**
FR-A- 1 398 580 **FR-A- 2 455 648**
FR-A- 2 485 576

• **PATENT ABSTRACTS OF JAPAN** vol. 17, no. 119
(C-1034) 12 March 1993 & JP-A-04 300 587
(HITACHI LTD) 23 October 1992

EP 0 686 721 B1

Note: Within nine months from the publication of the mention of the grant of the European patent, any person may give notice to the European Patent Office of opposition to the European patent granted. Notice of opposition shall be filed in a written reasoned statement. It shall not be deemed to have been filed until the opposition fee has been paid. (Art. 99(1) European Patent Convention).

Description

[0001] This invention relates to a method for optimizing water consumption by a washing machine, a washing-drying machine or the like in washing and rinsing a load or clothes placed in its usual drum, in accordance with the introduction to the main claim. The invention also relates to a device for implementing the aforesaid method.

[0002] EP-A-0 441984 suggests, in a washing machine, a control unit using the fuzzy logic to evaluate the clothes load and the water quantity in the different cycles using water conductivity measuring means.

[0003] Various arrangements (methods and corresponding devices) are known for reducing water consumption by a washing machine or the like, and in particular for achieving suitable water utilization at least during rinsing, on the basis of the quantity of detergent absorbed by the load, but these have various drawbacks. In particular, these known arrangements do not achieve the set object in that they either still result in excessive water utilization particularly during rinsing or, in attempting to overcome this, they do not result in total detergent removal from the load. This can result in an allergic user reaction to the detergent still present in the clothes when he wears them.

[0004] Methods and devices are known for evaluating the water quantity to be used in a washing machine during clothes washing and rinsing. In particular, devices are known which measure the water conductivity on termination of the wash stage or of a rinse stage in order to determine the water quantity to be used for the next stage in the treatment of the load in said machine. However these known devices and methods operate in accordance with logics comprising the definition of precise predetermined water levels based on the measured water conductivity. These levels can either be totally insufficient for complete detergent removal or be considerably higher than required for this removal.

[0005] Methods and devices are also known for evaluating the weight of the load placed in a washing machine or the like in order to define a suitable water quantity (which is hence fixed) for use in each machine operation stage. This water quantity is not changed in any way after the wash stage, even if after the first rinse stage the clothes retain only a minimum detergent quantity, which could be removed by a water volume much smaller than that set at the start of operation of the washing machine. Known methods and devices therefore do not completely attain the object of properly limiting the water quantity user, by the appliance during the treatment of the load, neither do they provide a metered water utilization, at least for each rinse stage, based on the detergent quantity still present in the load after the preceding treatment stage (such as a rinse stage).

[0006] An object of the present invention is to provide a method and corresponding device which over-

come the drawbacks of analogous known devices and methods.

[0007] A particular object of the invention is to provide a method and corresponding device which allow optimized water utilization in a washing machine or the like and in particular, during each rinse stage, on the basis of the detergent used for washing and remaining associated with the load after a preceding rinse stage.

[0008] A further object is to provide a method and corresponding device able to achieve high rinsing efficiency, ie able to free the clothes from the detergent for any fed quantity of this latter, even if the user has introduced into the usual drawer a detergent quantity greater than that required for washing the load being treated.

[0009] A further object is to provide a method and device able to achieve optimum washing and rinsing of the load even if its weight has been erroneously evaluated during the initial stage of its treatment.

[0010] A further object is to provide a method enabling the rinse stage to be shortened, with consequent reduction in the appliance operating costs.

[0011] These and further objects which will be apparent to the expert of the art are attained by a method and device for its implementation in accordance with the accompanying claims.

[0012] According to the invention at least the evaluation of the water quantity to be used in the rinse stage following a first wash stage is effected by the known fuzzy logic procedure. This latter has been known for some time and is used in various technical sectors. For example US4910684 describes a method for controlling a rotary kiln during its start-up. This text amply describes the use of fuzzy logic. This latter, as known and as described in said prior patent, uses rules defined by "linguistic operations" relative to the control actions to be taken on the basis of a given process condition, ie "if" a certain condition arises, "then" a certain control action is taken. The key elements in the control rules are terms such as "medium reduction", "open slightly", "high", "somewhat low" and the like. In linguistic approximation in accordance with fuzzy logic each of these terms is represented by a single fuzzy function which for a given process condition is used to establish a value within the range (0,1). Hence the logic value of a condition which in binary logic is usually restricted to "true" or "false" (0 or 1), can have any value within the range (0,1) in fuzzy logic, the logic value being a measure of the fulfilment of the condition for a given process state.

[0013] The present invention will be more apparent from the accompanying drawings, which are provided by way of non-limiting example and in which:

Figure 1 represents a block scheme of the device according to the invention;

Figure 1A is a schematic representation of a first embodiment of a washing machine provided with the device of the invention;

Figures 2 and 3 are schematic representations of a

second embodiment of a washing machine during two different stages of implementation of the method according to the invention;

Figure 4 represents part of the washing machine of Figures 2 and 3;

Figure 5 represents a flow diagram of the method of the invention applied to the washing machine of Figure 1A;

Figures 5A, 5B, 5C and 5D represent respectively: a table of the variables used by the fuzzy logic to execute the method of the invention in the machine of Figure 1A; a graph showing conductivity against grade value; a graph showing water level in a preceding rinse stage against grade value; and a graph showing water level regulation in a subsequent rinse stage against grade value, these graphs representing the fuzzy logic used by the device of Figure 1;

Figures 6 and 7 represent respectively a graph of time against rpm and a graph of time against current, these being used in a stage in the implementation of the method of Figure 5;

Figures 8, 9 and 10 represent respectively the table of the variables used by the fuzzy logic to execute a stage of the method of the invention and graphs in accordance with said logic showing current (DI) against grade value (Figure 9) and rinse water level (WRL) against grade value (Figure 10);

Figure 11 represents a more detailed flow diagram of the particular implementation of the method of Figure 5 in the machine of Figures 2, 3 and 4;

Figure 12 is a schematic representation of a third embodiment of a washing machine in which the method of the invention is implemented;

Figure 12A represents a detailed flow diagram of a particular implementation of the method of Figure 5 in the machine of Figure 12;

Figure 13 represents a stage in the method of Figure 12A;

Figure 14 represents a graph of time against conductivity, showing the variation in the conductivity of the water in the washing machine after a first, a second and a third rinse stage respectively.

[0014] With reference to Figures 1 to 4, a washing machine (or the like) comprises a cabinet 1, and a drum 2 rotating within a tub 3 into the top of which there opens a pipe 4 (from a usual detergent distribution drawer 5) and into the bottom of which, in the machine of Figures 2 and 3, there opens a pipe 6. This latter originates from a pipe 7 to which it is connected via a three-way solenoid valve 8, this pipe terminating in the drawer 5 and being connected, upstream of the solenoid valve 8, to a wash water feed pipe 10 and to a prewash water feed pipe 11. Solenoid valves 12 and 13 respectively are contained in these latter (see Figure 4).

[0015] With particular reference to Figures 1 and 1A, on the bottom of the tub 3 there is positioned a con-

ductivity sensor 14, for example a conductivity cell, a further sensor 14A being positioned in the pipe 7. Each sensor 14, 14A is connected to an operating and control unit 15 for the washing machine. This unit, preferably of microprocessor type, operates in accordance with fuzzy logic and is connected to a known current sensor 16 associated with the usual electric motor of the appliance and used to measure the current absorbed by said motor at least before the wash stage, to a pressure sensor 17 used to provide the unit 15 with a continuous indication of the water level in the tub 3, and to a temperature sensor 18 (for example a negative temperature coefficient or NTC sensor) to enable the unit 15 to measure the temperature of the water in the tub. The sensor 17 can be replaced by a flowmeter 18A to enable the tub 3 to be filled to a predetermined level. The unit 15 consequently continuously receives the signals from said sensors, and in accordance with fuzzy logic controls the solenoid valves 8, 12, 13, the possible flowmeter 18A, a usual heating element 19 positioned in the tub 3, a usual discharge pump 20, and an electric motor control member 21 (of known type). The unit 15 also dialogues with a usual interface 22 (such as a keypad, one or two knobs and a display) positioned on a face of the cabinet 1 (not shown) by which the user selects in known manner the wash program which the machine is to execute and notes the state of execution of this program.

[0016] Figure 1 also shows a usual power supply 23 from the electric mains 24.

[0017] The method of the invention will now be described with initial reference to Figures 1, 1A, 5, 5A, B, C, D and 6 to 10.

[0018] After selecting the wash program via the interface 22, the user presses the machine start button (not shown) to start the process shown in Figure 5.

[0019] The block 30 represents the start of the procedure of said method.

[0020] On pressing the start button, the unit 15 acts on the motor control member 21 to operate the appliance electric motor. By means of this action the motor (see Figure 6) firstly gradually increases its rpm and then undergoes a steep rise (ramp) by considerably increasing its rpm within a very short time, followed by its stoppage. This corresponds to the motor current absorption shown in Figure 7, which shows a current peak value (IMAX) and a mean reference value (IREF) calculated in any known manner. At this point the unit 15 evaluates the difference DI between the current IMAX and the current IREF.

[0021] As shown for example in Figure 9, with fuzzy logic the values of the grade value of the calculated value DI are divided within the cartesian plane into areas in accordance with the known rules of this logic: the area A1 corresponds to a low grade value (L1), the area A2 corresponds to a medium degree (M) and the area A3 corresponds to a high degree (H). For example, if the value DI is 285, then in fuzzy logic DI has a low

grade value of about 40% and a medium of about 70%. According to said logic and consequently in known manner, the unit 15 determines substantially the output values weighted on the basis of said grade values, and in accordance with the known mathematical formula:

$$\text{COG} = \frac{\sum_{i=1}^n \mu(X_i) X_i}{\sum_{i=1}^n \mu(X_i)}$$

calculates the resultant value corresponding to the water quantity to be used in the next operating stage of the washing machine. In the formula, in known manner:

- COG is the centre of gravity of the sum of the resultant vectors pertaining to the assemblage of vectors determined via the respective output junctions according to values defined in fuzzy logic as shown schematically in Figure 10;
- $\mu(X_i)$ is the generic vector corresponding to the vertex of each geometrical figure (triangle) in Figure 10, this vector having an amplitude defined on the basis of the grade value determined as described in relation to Figure 9;
- X_i is the generic abscissa value corresponding to the aforesaid vector.

[0022] The resultant output, hence corresponding to the centre of gravity of the individual outputs weighted in accordance with the known rules of fuzzy logic, is calculated by the unit 15. All this is achieved in the blocks 31 (current measurement) and 32 (fuzzy logic routine execution) in which the weight of the load placed in the drum 2 is evaluated (Figure 5).

[0023] Having determined the value DI (and hence the weight of the load in the drum 3) by the rules of fuzzy logic (shown schematically in the "truth table" of Figure 8) and using this value as "input data", the unit 15 uses known calculation algorithms to define in proportion the water quantity (in litres or in terms of levels) necessary for effectively washing said load and for effecting a first rinse stage (or simply a first rinse).

[0024] The blocks 31, 32 and 33 define a stage 34 in which the weight of the load and of the water required for its washing and for the first rinse are determined. Alternatively the stage 34 can be used for determining the water quantity to be used for only the first rinse stage, the water quantity to be used for the wash being unequivocally determined by the attainment of a suitable water level in the tub 3. This level is attained and checked (by the unit 15) via the flowmeter 18A, if provided.

[0025] After the stage corresponding to the block 33, the unit 15 starts the washing of the load (block 35).

During this latter the unit monitors the water level by means of the pressure sensor 17 and its temperature by means of the sensor 18. The stage represented by the block 35 is effected by usual procedures, and on their termination (evaluated in the stage represented by the block 36) the pump 20 is activated to discharge the water from the tub 3.

[0026] Simultaneously the drum 2 is made to rotate (in known manner) at a spinning speed such as to expel water from the load.

[0027] A further stage 34 can then be executed to improve the evaluation of the load weight before executing the rinse stage so as to optimize the value representing the water quantity to be used for implementing the first rinse stage. This further stage 34 following the wash could also totally replace the analogous stage preceding the wash.

[0028] After emptying the tub 3 and after the said spinning, a first rinse stage (block 37) starts, effected by introducing into the tub a water quantity evaluated in the stage corresponding to the block 33 (or the equivalent stage executed after the wash).

[0029] During this rinse the conductivity of the water in the tub 3 is evaluated continuously. This is done in the manner described hereinafter.

[0030] When the first rinse terminates (evaluated within the block 38), for example when a suitable time period (typically 180 seconds) has passed from its commencement, the unit 15 evaluates the relative conductivity of the water by comparing (by difference) the conductivity (reference conductivity, Cr) of the water introduced into the tub 3 and the conductivity (Cd) evaluated during the rinse stage. On the basis of this evaluation (block 39) and the water quantity used in this first rinse stage, the unit 15 operating (block 40) by fuzzy logic determines (block 41) the new water level to be used in the subsequent second rinse stage (block 42) after the water used in the preceding rinse stage has been discharged.

[0031] The block 42 is followed by the blocks 43, 44, 45 and 46 which execute stages identical to and corresponding to the stages 38, 39, 40 and 41 respectively.

[0032] In the stage represented by the block 46 an evaluation is made (in the aforesaid manner) of the water quantity to be used in a third rinse (block 47), as is usually included in the operating program of the washing machine. On termination of this latter or when the end of said third rinse has been evaluated (block 48), the unit 15 finally discharges the water from the tub 3 and halts the machine (block 49) after a usual spin stage.

[0033] In particular it should be noted that the evaluation of the water conductivity during stage 44 is done by comparing the conductivity (Cr) of the water introduced into the tub 3 (measured continuously by the sensor 14A) with that of the water present in the tub 3 after the second rinse. This latter value is different from the corresponding value used in block 39 because the first

rinse has already removed a large part of the detergent (responsible for the conductivity variation of the water coming into contact with the load after its washing, compared with the reference value C_r) from the clothes in the drum 2.

[0034] A different embodiment of the previously described (general) method represented in Figure 5 will now be described with reference to the washing machine embodiment shown in Figures 2, 3 and 4 and with reference to Figure 11. In these figures, parts corresponding to the already described figures are indicated by the same reference numerals.

[0035] As has been already stated and as is well known, the conductivity of the water (or rather of the aqueous solution) present in the tub 3 is a value representative of the quantity of detergent dissolved in the water or of how much detergent remains associated with the clothes contained in the drum after their wash or after the preceding rinse stage. This value generally decreases with the successive rinses, but how it varies cannot be predefined with certainty. This value in fact depends on various variables such as the type of clothes fabric and the quantity and type of detergent introduced into the drawer 5.

[0036] To initialize the unit 15 with regard to the reference conductivity (C_r) of the water entering the tub 3, the unit 15 executes for example stage 51 of the method shown in Figure 11.

[0037] At a first moment (block 52) the unit 15 acts on the solenoid valve 8 to close access to the drawer 5 by the water originating from at least one of the pipes 10, 11, and to feed it into the pipe 6 (this being shown by the block 52 of Figure 11). Following this, said unit operates at least one solenoid valve 12 or 13 (to feed water into the tub) and evaluates the water level in the tub 3 without operating the motor via the member 21. When a predetermined minimum level of water sufficient to enable its conductivity to be measured by the sensor 14 has been reached in said tub, the unit 15 returns the valve 8 to the position closing the pipe 6 to the water and enabling it to flow into the drawer 5.

[0038] This unit then determines the value of the conductivity measured by the sensor 14 (block 54) and takes it as the reference value C_r .

[0039] The successive evaluations (blocks 39 and 44) of the difference between the measured or instantaneous value (C_d) and the reference value (C_r) can be carried out according to any known method.

[0040] A further example of evaluating the water conductivity and its consequences for defining, in accordance with fuzzy logic, the water quantity to be used in each rinse subsequent to the first is given in Figures 12 to 14, in which parts corresponding to those of the already described figures are indicated by the same reference numerals. Specifically, the washing machine of Figure 12 is similar to that of Figure 1A, but is without the sensor 14A.

[0041] It will be assumed that each rinse (Figure

14) comprises a first phase "i" in which water is fed into the tub 3, a phase "a" in which the load is agitated (possibly comprising the phase "i") and a phase "ds" of predetermined duration during which this load is spun and the water discharged. In particular, following the commencement of each rinse (block 13A of Figure 13), ie in the instability phase, the conductivity undergoes considerable swings related to the "fall" of the water containing detergent (taken from the load) in the tub. According to the particular aspect of the invention, when the load agitation phase commences (phase "a" in Figure 14) there is a first evaluation of the water conductivity measurement (block 13B of Figure 13).

[0042] During the entire agitation phase "a" and hence for a time T_1 (as shown in Figure 14) in relation to the first rinse, or T_2 or T_3 for the other rinses, the conductivity measured by the sensor 14 increases in accordance with an exponential law (curve X). In order to evaluate the detergent concentration in the water the unit 15 analyzes the angle γ which the tangent Z to the curve X forms with a straight line P parallel to the conductivity axis passing through that point on the time axis at the commencement of the period subsequent to the instability phase "i", ie at the start of the period T_1 (ie when the unit 15 detects a continuously increasing conductivity). The aforesaid evaluation is executed in accordance with the flow diagram of Figure 13 and as indicated by the block 37A (or 42A) of Figure 12A. In particular, the determination of the angle γ is effected indirectly by evaluating the angle α and remembering that $\gamma_n = 90^\circ - \alpha_n$ where the subscript n indicates the different rinses and the angle α is the angle which the said tangent Z forms with a straight line Q parallel to the time axis and passing through the point of tangency between the straight line Z and the curve X.

[0043] More specifically, with reference to Figure 13, after determining the conductivity value C_1 the unit 15 waits (block 13C of Figure 13) a predetermined time and after having determined (block 13D) the end of this time it reads the conductivity value (C_2) attained at each moment by the water in the tub during the period T_1 (block 13E) or during the equivalent periods of the other rinses. Said unit then calculates the difference between this value and the reference value (block 13F) so as to define a conductivity variation ($\Delta C = C_2 - C_1$) which together with the time T_1 is used (block 13G) by the unit 15 to determine in accordance with fuzzy logic the value of the angle γ from the angle α using known calculation algorithms. This value is representative of the quantity of detergent present in the load before the start of the relative rinse stage and is used by the unit 15 to determine in accordance with fuzzy logic (and by procedures analogous to those described heretofore in relation to Figures 5A, B, C, D) the water quantity to be used for the next rinse.

[0044] Following determination of the angle α (and hence of the angle γ), the unit 15 compares

(block 13H) its value with a predetermined value (Γ) and if less than this latter it proceeds to recalculate the conductivity value after replacing the reference value (C1) with that previously calculated (C2). If however this value is lower than the predetermined value (Γ) the rinsing is halted (block 13L). This is because the conductivity variation is negligible or less than an optimum predetermined minimum value. Consequently by measuring the conductivity variation it is possible to determine the moment in which it can be considered that the load agitation (phase "a" of the rinse) has reached termination as it is no longer possible to further remove detergent associated with the clothes after said rinse phase.

[0045] The angle gamma is evaluated during each rinse. As can be seen from the aforesaid figures, the angle gamma (indicated by the subscripts 1, 2 and 3 depending on the rinse) tends to become increasingly larger (ie the angle alpha becomes increasingly smaller), this being representative of a decrease in the quantity of detergent removed from the load contained in the drum 2. Rinsing is halted on reaching the aforesaid situation leading to the block 13L of Figure 14 (this condition usually being reached at the third rinse). Alternatively, rinsing is halted after a predetermined time.

[0046] As stated, the value of the angle gamma (indirectly obtained from the angle alpha) is used by the unit 15 to determine by fuzzy logic the quantity of water to introduce into the tub for the operating stage following the preceding one in which said angle was calculated. This is done by taking into consideration the water quantity used in the preceding spin calculated by the rules of fuzzy logic (analogously to that shown in Figures 5A, B, C and D).

[0047] Because of fuzzy logic this determination is as accurate as possible and enables water utilization to be optimized during the entire wash and rinse cycle of the appliance. Said logic results in substantially continuous definition of the water quantity to be used in the washing machine for removing the detergent from the load without the need for approximations (generally in excess) which usually lead to a considerable wastage of water.

[0048] In addition, by properly gauging the water quantity to be fed into the machine during the various stages of its operation and particularly during the rinse stage, the time of execution of this latter is shortened leading to a considerable saving in time and energy.

Claims

1. A method for optimizing water utilization in a washing machine (1), washing-drying machine or the like during its use, said machine treating a load or clothes placed in a drum (2) rotating within a tub (3) and driven by an electric motor, said treatment comprising a wash stage and a plurality of successive rinse stages, the weight of the load in the drum

(2) and the conductivity of the wash water and/or of the water of any rinse stage being evaluated in order to obtain at least one definition of the water quantity to be used for rinsing, this evaluation being in accordance with fuzzy logic, characterized in that the determination of the water conductivity, representative of the quantity of detergent absorbed by the clothes, is effected in each rinse stage, this evaluation allowing proper determination of the water quantity to be introduced into the machine tub (3) for the execution of each subsequent rinse stage to enable said detergent quantity to be reduced to a value less than a minimum predetermined value, said water quantity to be introduced into the tub (3) being gauged on the detergent quantity, as evaluated by fuzzy logic, which has remained associated with the load after a preceding stage in the treatment thereof.

2. A method as claimed in claim 1, characterized in that a value corresponding to the water quantity in a preceding rinse (37, 42) is used, in combination with the value corresponding to the detergent quantity present in said preceding rinse, to determine in accordance with fuzzy logic the water quantity to be introduced into the tub (3) to execute the next rinse stage (42, 47).

3. A method as claimed in claim 1, characterised in that the fuzzy logic evaluation of the water quantity to be utilized at least for the first rinse stage (37) is effected on the basis of the weight of the load introduced into the rotating drum (2) and also evaluated in accordance with this logic.

4. A method as claimed in claim 3, characterised in that the fuzzy logic evaluation of the load weight is also used to define the water quantity to be used for executing the wash stage.

5. A method as claimed in claim 3 or 4, characterised by determining by fuzzy logic a characteristic of the electric motor (31) on the basis of which the weight of the load placed in the drum (2) is determined, the value of said characteristic being used by said logic to successively determine the quantity of water to be introduced into the tub (3) for washing the load (35) and/or for the first rinse stage (37).

6. A method as claimed in claim 1, characterised by comprising, following the washing of the load (35) but before the first rinse stage (37), a further stage (34) of evaluating by fuzzy logic the weight of the load introduced into the drum.

7. A method as claimed in claim 1, characterised in that, prior to the wash (35) and following the load weight evaluation stage (34), a stage (51) is exe-

cuted in which the conductivity of the water introduced into the tub (3) is evaluated to be taken as a reference value.

8. A method as claimed in claim 1, characterised in that the fuzzy logic evaluation of the detergent quantity dissolved in the water in the tub (3) is effected by measuring the water conductivity at least at the start of each rinse stage (37, 42). 5
9. A device for implementing the method of claim 1 in a washing machine of the type comprising a control unit (15) for the wash program of the appliance and an electric motor for rotating a drum within a tub to which wash water is fed, said control unit (15) being connected at least to means (14) for measuring the conductivity of the water which has definitely come into contact with the clothes in the rotating drum (2) characterized in that said control unit (15) operates in accordance with the rules of the fuzzy logic to evaluate the water quantity necessary in the washing and/or rinsing stages on the box of the measured conductivity. 10 15 20
10. A device as claimed in claim 9, characterised by comprising further means (14a) for measuring the conductivity of the water which has been introduced into the tub (3) but has not come into contact with the clothes, said means being connected to the unit (15) operating in accordance with fuzzy logic. 25 30
11. A device as claimed in claim 9, characterised by comprising means (16) for measuring a parameter characteristic of the electric motor and connected to the unit (15) operating in accordance with the rules of fuzzy logic, said means (16) enabling said unit to evaluate the weight of the load introduced into the rotating drum (2). 35
12. A device as claimed in claim 9, characterised in that the means (14) for measuring the conductivity of the water which has definitely come into contact with the load in the rotating drum (2) are positioned within the tub (3) in proximity to its bottom. 40
13. A device as claimed in claim 10, characterised in that the further conductivity measurement means (14a) are positioned within a pipe (7) for feeding water to a usual detergent drawer (5). 45 50
14. A device as claimed in claim 10, characterised by comprising a pipe (6) which connects to the bottom of the tub (3) the pipe (7) feeding water to the detergent drawer, at the intersection between said pipes there being provided a controlled valve member arranged to direct the water introduced into the machine initially towards said bottom of the tub (3) and then towards said drawer (5), in correspond-

ence with said bottom there being positioned means for measuring the conductivity of the water entering the machine and then the conductivity of the water which has come into contact with the load containing the detergent.

Patentansprüche

1. Verfahren zur Optimierung der Wasserausnutzung einer Waschmaschine (1), einer Wasch-Trocknungsmaschine oder dergleichen während ihrer Benutzung, wobei diese Maschine eine Ladung oder Wäsche behandelt, die in eine in einer Wanne (3) rotierende und durch einen Elektromotor betriebene Trommel (2) eingelegt ist, diese Behandlung aus einem Waschschrift und einer Vielzahl von aufeinanderfolgenden Spülschritten besteht, das Gewicht der Ladung in der Trommel (2) und die Leitfähigkeit des Waschwassers und/oder des Wassers für jeden Spülschritt ausgewertet wird, um mindestens eine Festlegung der beim Spülen zu verwendenden Wassermenge zu erhalten, und diese Auswertung nach der Fuzzy-Logik erfolgt, dadurch gekennzeichnet,

dass die Bestimmung der Wasserleitfähigkeit, die für die Menge des von der Wäsche absorbierten Reinigungsmittels repräsentativ ist, während jedes Spülschritts erfolgt, wobei diese Auswertung eine genaue Bestimmung der in die Maschinenwanne (3) einzulassenden Wassermenge für die Ausführung jedes der aufeinanderfolgenden Spülschritte erlaubt, damit diese Reinigungsmittelmenge auf einen Wert verringert werden kann, der geringer als ein bestimmter Minimalwert ist, und wobei die in die Wanne (3) einzulassende Wassermenge genau nach der Reinigungsmittelmenge abgemessen ist, die nach der Fuzzy-Logik berechnet und in der Ladung nach einem vorhergehenden Behandlungsschritt verblieben ist.

2. Verfahren nach Anspruch 1, dadurch gekennzeichnet,

dass ein Wert, der der Wassermenge für ein vorhergehendes Spülen (37, 42) entspricht, in Kombination mit einem Wert, der der beim vorhergehenden Spülen verwendeten Reinigungsmittelmenge entspricht, nach der Fuzzy-Logik zur Bestimmung derjenigen Wassermenge dient, die in die Wanne (3) zur Ausführung des nächsten Spülschritts (42, 47) einzulassen ist.

3. Verfahren nach Anspruch 1, dadurch gekennzeichnet,

dass die Fuzzy-Logikauswertung der mindestens für den ersten Spülschritt (37) auszunutzenden Wassermenge auf der Basis des nach der Fuzzy-Logik ausgewerteten Gewichts der in die Drehtrommel (2) eingeführten Ladung erfolgt.

4. Verfahren nach Anspruch 3, dadurch gekennzeichnet,

dass die Fuzzy-Logikauswertung des Ladungsgewichts auch zur Bestimmung derjenigen Wassermenge verwendet wird, die zur Ausführung des Waschschriffs zu verwenden ist.

5. Verfahren nach Anspruch 3 oder 4, dadurch gekennzeichnet,

dass nach der Fuzzy-Logik ein Leistungsmerkmal des Elektromotors (31) bestimmt wird und dass auf der Basis dieses Leistungsmerkmals das Gewicht der in die Trommel (2) eingelegten Ladung bestimmt wird, wobei der Wert dieses Leistungsmerkmals von dieser Logik dazu benutzt wird, die in die Wanne (3) zum Waschen der Ladung (35) und/oder für den ersten Spülschritt (37) einzulassende Wassermenge aufeinanderfolgend festzulegen.

6. Verfahren nach Anspruch 1, dadurch gekennzeichnet,

dass ein weiterer Schritt (34) vorgesehen ist, der dem Waschen der Ladung (35) folgt, jedoch vor dem ersten Spülschritt (37) liegt, und der nach der Fuzzy-Logik das Gewicht der in die Trommel eingelegten Ladung auswertet.

7. Verfahren nach Anspruch 1, dadurch gekennzeichnet,

dass vor dem Waschen (35) und nach dem Schritt (34) zur Auswertung des Ladungsgewichts ein Schritt (51) ausgeführt wird, bei dem die Leitfähigkeit des in die Wanne (3) eingelassenen Wassers ausgewertet wird, um als Bezugswert zu dienen.

8. Verfahren nach Anspruch 1, dadurch gekennzeichnet,

dass die Fuzzy-Logikauswertung der im Wasser in der Wanne (3) gelösten Reinigungsmittelmenge dadurch bewirkt wird, dass die Wasserleitfähigkeit mindestens beim Start jedes Spülschritts (37, 42) gemessen wird.

9. Vorrichtung zur Durchführung des Verfahrens nach Anspruchs 1 in einer Waschmaschine mit einer Steuereinheit (15) für das Waschprogramm der Maschine und einem Elektromotor zum Drehen einer Trommel in der Wanne, der Waschwasser zugeführt wird, wobei die Steuereinheit (15) mindestens mit Mitteln (14) zur Messung der Leitfähigkeit des Wassers verbunden ist, das bestimmt mit der in der Drehtrommel (2) vorhandenen Wäsche in Berührung kommt, dadurch gekennzeichnet,

dass die Steuereinheit (15) nach den Regeln der Fuzzy-Logik arbeitet, um diejenige Wassermenge, die in den Wasch- und/oder Spülschritten nötig ist, auf der Basis der gemessenen Leitfähigkeit auszuwerten.

10. Vorrichtung nach Anspruch 9, dadurch gekennzeichnet,

dass weitere Mittel (14A) zur Messung der Leitfähigkeit des Wassers, das in die Wanne (3) eingelassen worden, aber nicht mit der Wäsche in Berührung gekommen ist, vorgesehen sind, wobei diese Mittel mit der nach der Fuzzy-Logik arbeitenden Steuereinheit (15) verbunden sind.

11. Vorrichtung nach Anspruch 9, dadurch gekennzeichnet,

dass Mittel (16) zur Messung eines Leistungsparameters des Elektromotors vorgesehen und mit der nach den Regeln der Fuzzy-Logik arbeitenden Steuereinheit verbunden sind und dass diese Mittel (16) der Einheit ermöglichen, das Gewicht der in die Drehtrommel (2) eingelegten Ladung auszuwerten.

12. Vorrichtung nach Anspruch 9, dadurch gekennzeichnet,

dass die Mittel (14) zur Messung der Leitfähigkeit des bestimmt mit der Ladung in der Drehtrommel (2) in Berührung kommenden Wassers in der Wanne (3) in der Nähe des Bodens der Wanne angeordnet sind.

13. Vorrichtung nach Anspruch 10, dadurch gekennzeichnet,

dass die weiteren Leitfähigkeitsmeßmittel (14A) in einer Leitung (7) zur Zuführung von Wasser zu einem üblichen Reinigungsmittelschub (5) angeordnet sind.

14. Vorrichtung nach Anspruch 10,

dadurch gekennzeichnet,

dass eine Leitung (6) vorgesehen ist, die die Wasser zum Reinigungsmittleinschub zuführende Leitung (7) mit dem Boden der Wanne (3) verbindet,

dass am Schnittpunkt dieser Leitungen ein gesteuertes Ventilglied vorgesehen ist, das derart ausgebildet ist,

dass es das in die Maschine eingelassene Wasser anfangs zum Boden der Wanne (3) und dann zum Einschub (5) hin lenkt, und

dass in Verbindung mit dem Wannensboden Mittel zur Messung der Leitfähigkeit des in die Maschine eingelassenen Wassers und dann der Leitfähigkeit desjenigen Wassers angeordnet sind, das mit der das Reinigungsmittel enthaltenden Ladung in Berührung gekommen ist.

Revendications

1. Procédé pour optimiser l'utilisation d'eau dans un lave-linge (1), un lave-linge - séchoir ou analogue pendant son utilisation, ledit lave-linge traitant une charge ou des vêtements placés dans un tambour (2) tournant à l'intérieur d'une cuve (3) entraînée par un moteur électrique, ledit traitement comprenant une étape de lavage et une pluralité d'étapes successives de rinçage, le poids de la charge dans le tambour (2) et la conductivité de l'eau de lavage et/ou de l'eau de l'une quelconque des étapes de rinçage étant évalués pour l'obtention d'au moins une définition de la quantité d'eau devant être utilisée pour le rinçage, cette évaluation étant effectuée conformément à la logique floue, caractérisé en ce que la détermination de la conductivité de l'eau, qui est représentative de la quantité de détergent absorbée par les vêtements, est exécutée lors de chaque étape de rinçage, cette évaluation permettant une détermination correcte de la quantité d'eau devant être introduite dans la cuve (3) de la machine pour l'exécution de chaque étape de rinçage suivante de manière à permettre une réduction de ladite quantité de détergent à une valeur inférieure à une valeur minimale prédéterminée, ladite quantité d'eau devant être introduite dans la cuve (3) étant calibrée en fonction de la quantité de détergent, qui est évaluée par la logique floue et est restée fixée à la charge après une étape précédente lors du traitement de cette charge.
2. Procédé selon la revendication 1, caractérisé en ce qu'on utilise une valeur correspondant à la quantité d'eau lors d'une étape de rinçage (37,42), en combinaison avec la valeur correspondant à la quantité de détergent présente lors dudit rinçage précédent, pour déterminer, conformément à la logique floue, la quantité d'eau devant être introduite dans la cuve (3) pour exécuter l'étape suivante de rinçage (42,47).
3. Procédé selon la revendication 1, caractérisé en ce que l'évaluation, au moyen de la logique floue, de la quantité d'eau devant être utilisée au moins pour la première étape de rinçage (37) est exécutée sur la base du poids de la charge introduite dans le tambour rotatif (2) et est également évaluée conformément à cette logique.
4. Procédé selon la revendication 3, caractérisé en ce que l'évaluation, au moyen de la logique floue, du poids de la charge est également utilisée pour définir la quantité d'eau devant être utilisée pour exécuter l'étape de lavage.
5. Procédé selon la revendication 3 ou 4, caractérisé par la détermination, au moyen de la logique floue, d'une caractéristique du moteur électrique (31), sur la base de laquelle le poids de la charge placée dans le tambour (2) est déterminé, la valeur de ladite caractéristique étant utilisée par ladite logique pour déterminer successivement la quantité d'eau devant être introduite dans la cuve (3) pour le lavage de la charge (35) et/ou pour la première étape de rinçage (37).
6. Procédé selon la revendication 1, caractérisé en ce qu'il comprend, à la suite du lavage de la charge (35), mais avant la première étape de rinçage (37), une étape suivante (34) d'évaluation, au moyen de la logique floue, du poids de la charge introduite dans le tambour.
7. Procédé selon la revendication 1, caractérisé en ce qu'avant le lavage (35) et après l'étape (34) d'évaluation du poids de la charge, une étape (51) est exécutée, lors de laquelle la conductivité de l'eau introduite dans la cuve (3) est évaluée pour être prise en tant que valeur de référence.
8. Procédé selon la revendication 1, caractérisé en ce que l'évaluation, au moyen de la logique floue, de la quantité de détergent dissoute dans l'eau à l'intérieur de la cuve (3) est exécutée au moyen d'une mesure de la conductivité de l'eau au moins lors du démarrage de chaque étape de rinçage (37,42).
9. Dispositif pour la mise en oeuvre du procédé selon la revendication 1 dans un lave-linge du type comprenant une unité de commande (15) pour le programme de lavage de l'appareil et un moteur électrique pour faire tourner un tambour à l'intérieur d'une cuve, dans laquelle une eau de lavage est introduite, ladite unité de commande (15) étant connectée au moins à des moyens (14) pour mesurer la conductivité de l'eau, qui est venue, d'une

manière définie, en contact avec les vêtements situés dans le tambour rotatif (2), caractérisé en ce que ladite unité de commande (15) fonctionne conformément aux règles de la logique floue pour évaluer la quantité d'eau nécessaire lors des étapes de lavage et/ou de rinçage, sur la base de la conductivité mesurée. 5

10. Dispositif selon la revendication 9, caractérisé en ce qu'il comprend en outre des moyens (14a) pour mesurer la conductivité de l'eau qui a été introduite dans la cuve (3), mais n'est pas venue en contact avec les vêtements, lesdits moyens étant connectés à l'unité (4) fonctionnant conformément à la logique floue. 10 15

11. Dispositif selon la revendication 9, caractérisé en ce qu'il comporte des moyens (16) pour mesurer un paramètre caractéristique du moteur électrique, connectés à l'unité (4) fonctionnant conformément aux règles de la logique floue, lesdits moyens (16) permettant à ladite unité d'évaluer le poids de la charge introduite dans le tambour rotatif (2). 20

12. Dispositif selon la revendication 9, caractérisé en ce que les moyens (14) pour mesurer la conductivité de l'eau, qui vient en contact, d'une manière définie, avec la charge située dans le tambour rotatif (2) sont positionnés à l'intérieur de la cuve (3), à proximité de son fond. 25 30

13. Dispositif selon la revendication 10, caractérisé en ce que les autres moyens de mesure de conductivité (14a) sont disposés dans une canalisation (7) servant à envoyer de l'eau à un tiroir usuel à détergent (5). 35

14. Dispositif selon la revendication 10, caractérisé en ce qu'il comporte une canalisation (6) qui raccorde le fond de la cuve (3) à la canalisation (7) amenant l'eau au tiroir à détergent, tandis qu'au niveau de l'intersection entre lesdites canalisations il est prévu un élément de soupape commandé, agencé de manière à introduire l'eau initialement introduite dans la machine en direction dudit fond de la cuve (3), puis en direction dudit tiroir (5), et qu'en rapport avec ledit fond de la cuve sont disposés des moyens pour mesurer la conductivité de l'eau pénétrant dans la machine, puis la conductivité de l'eau qui est venue en contact avec la charge contenant le détergent. 40 45 50

55

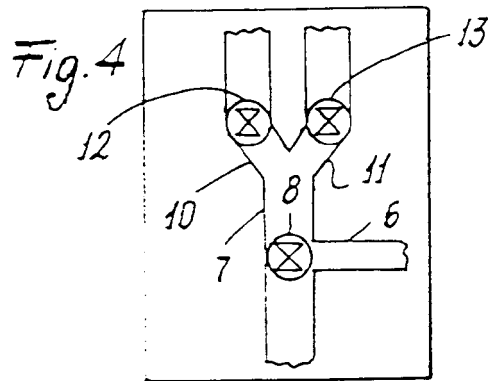
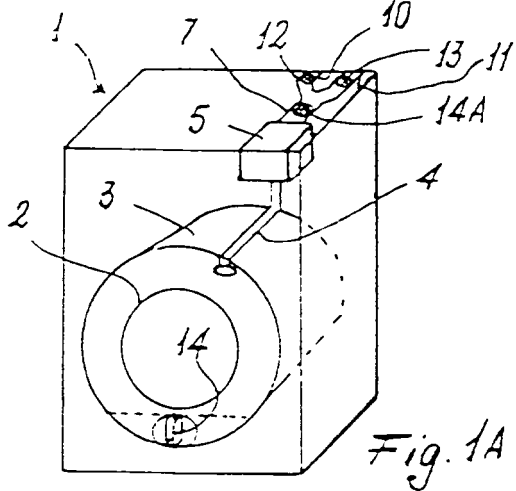
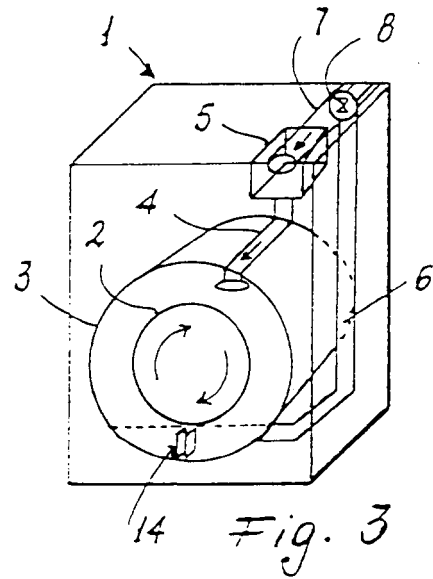
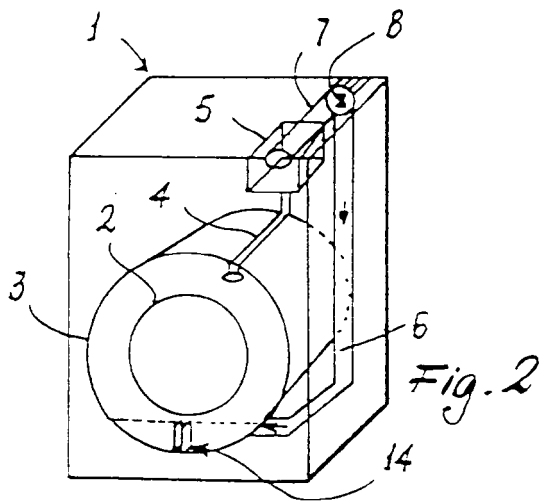
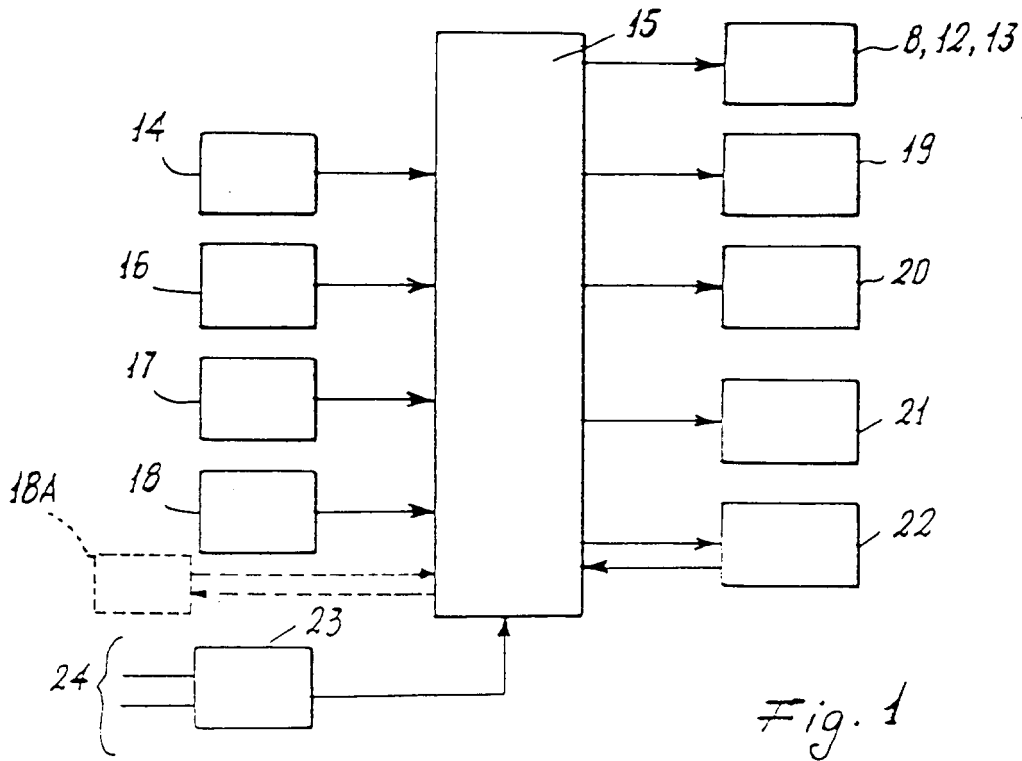

PREVIOUS WATER LEVEL CONDUCTIVITY VARIATION	LOW	MEDIUM	HIGH
SMALL	ZERO (Z)	SMALL POSITIVE (SP)	LARGE POSITIVE (LP)
MEDIUM	SMALL NEGATIVE (SN)	ZERO (Z)	SMALL POSITIVE (SP)
LARGE	LARGE NEGATIVE (LN)	SMALL NEGATIVE (SN)	ZERO (Z)

Fig. 5A

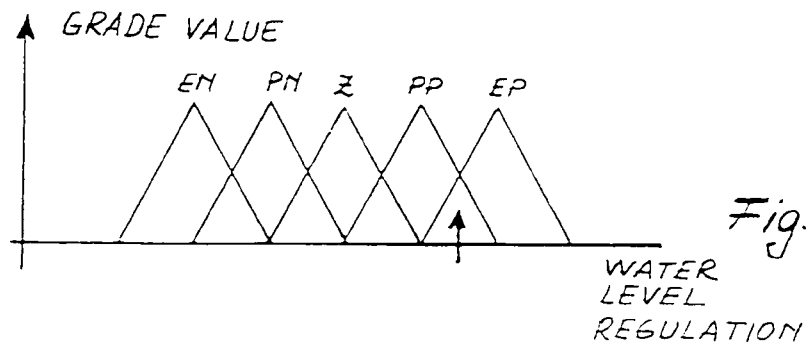
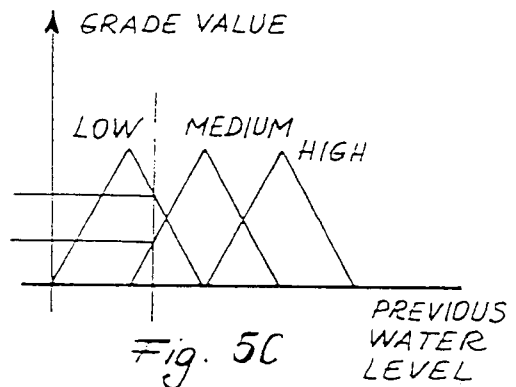
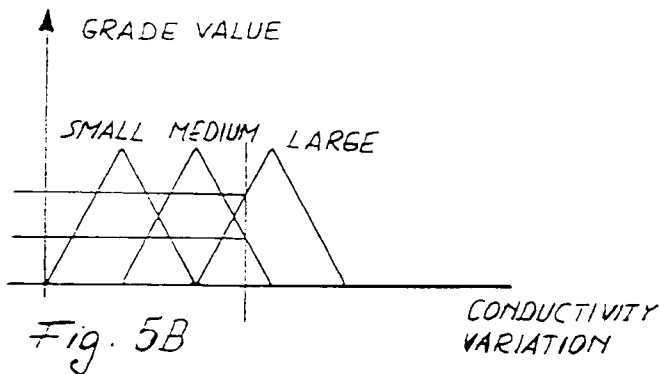

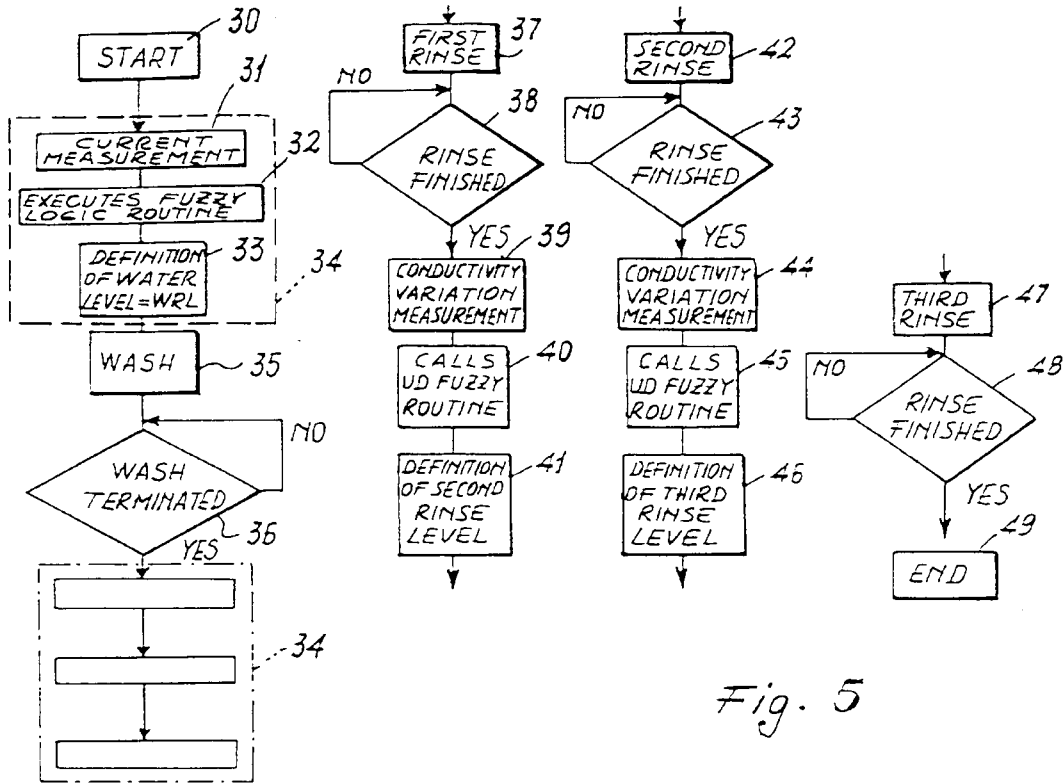

Fig. 5

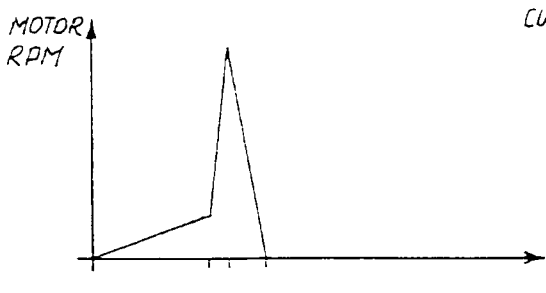

Fig. 6

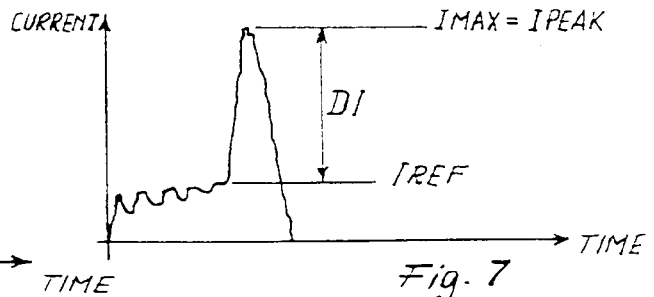

Fig. 7

INPUT DI	L	M	H
OUTPUT WRL	L	M	H

Fig. 8

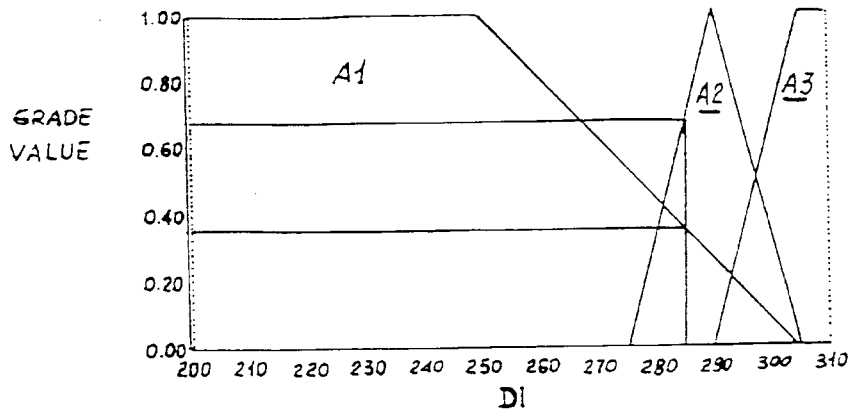

Fig. 9

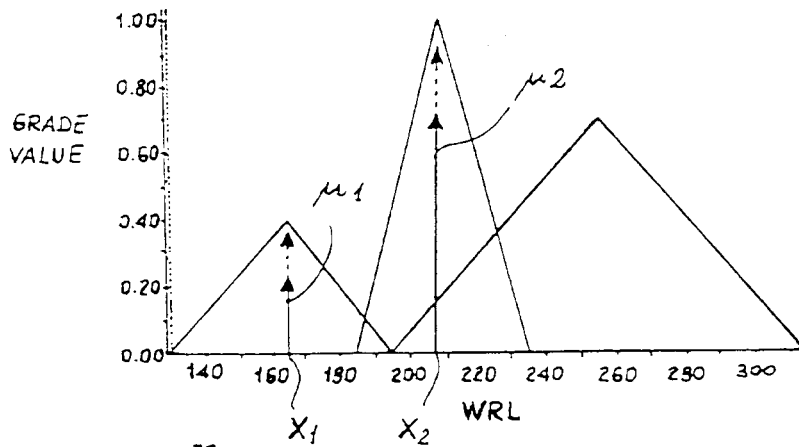

Fig. 10

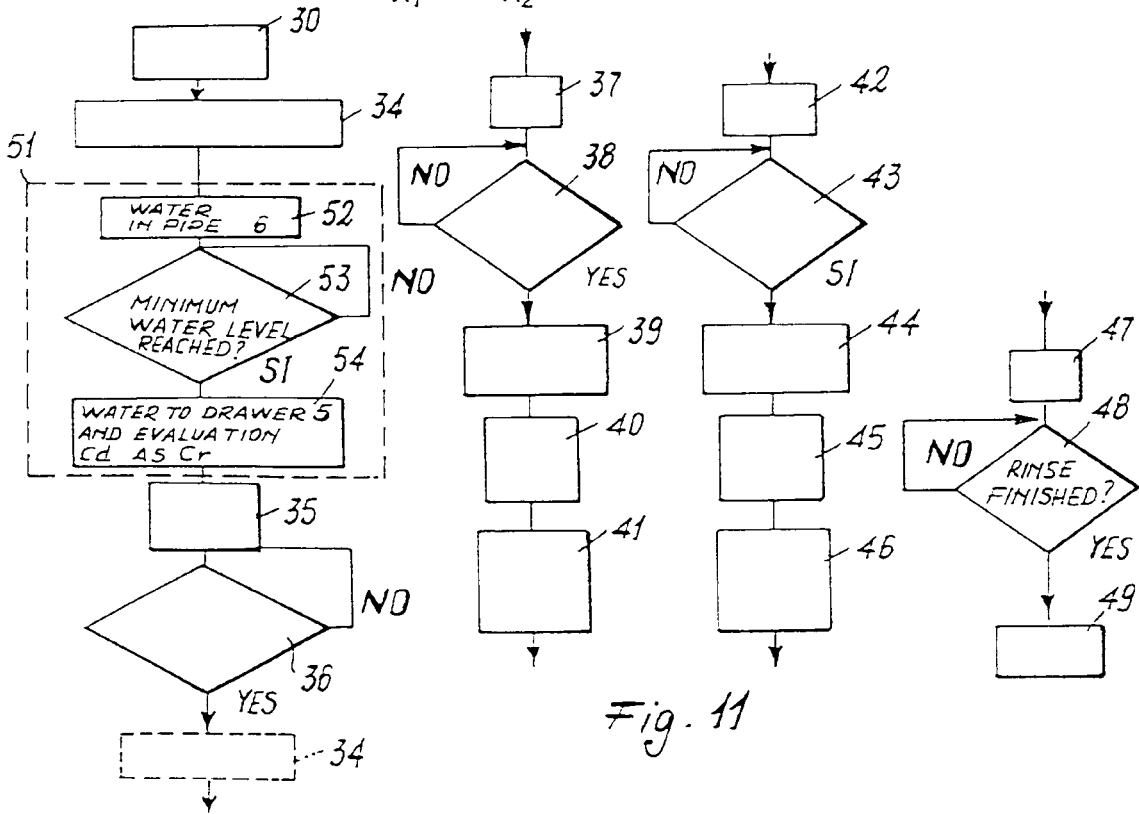

Fig. 11

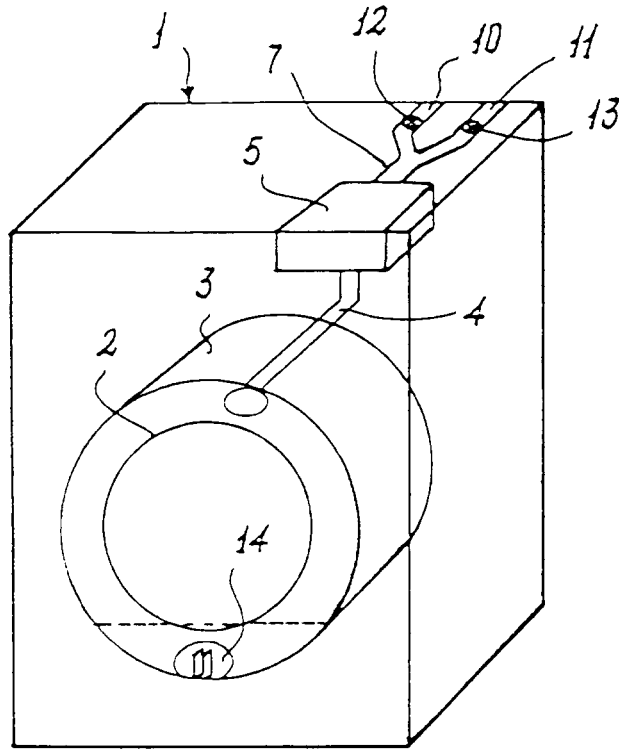

Fig. 12

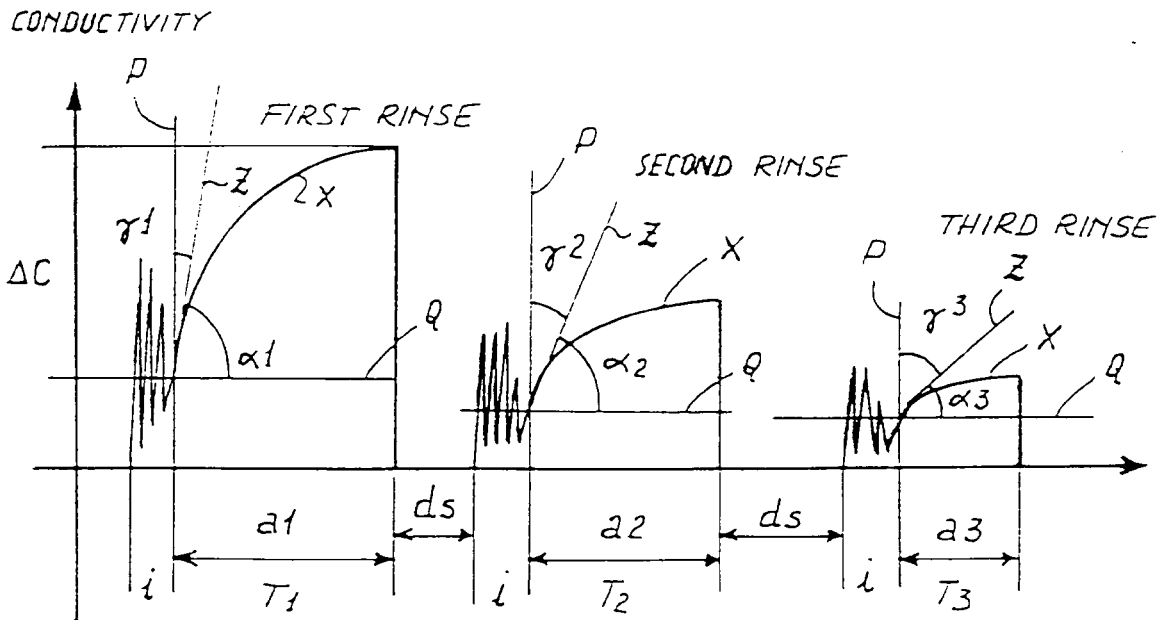

Fig. 14

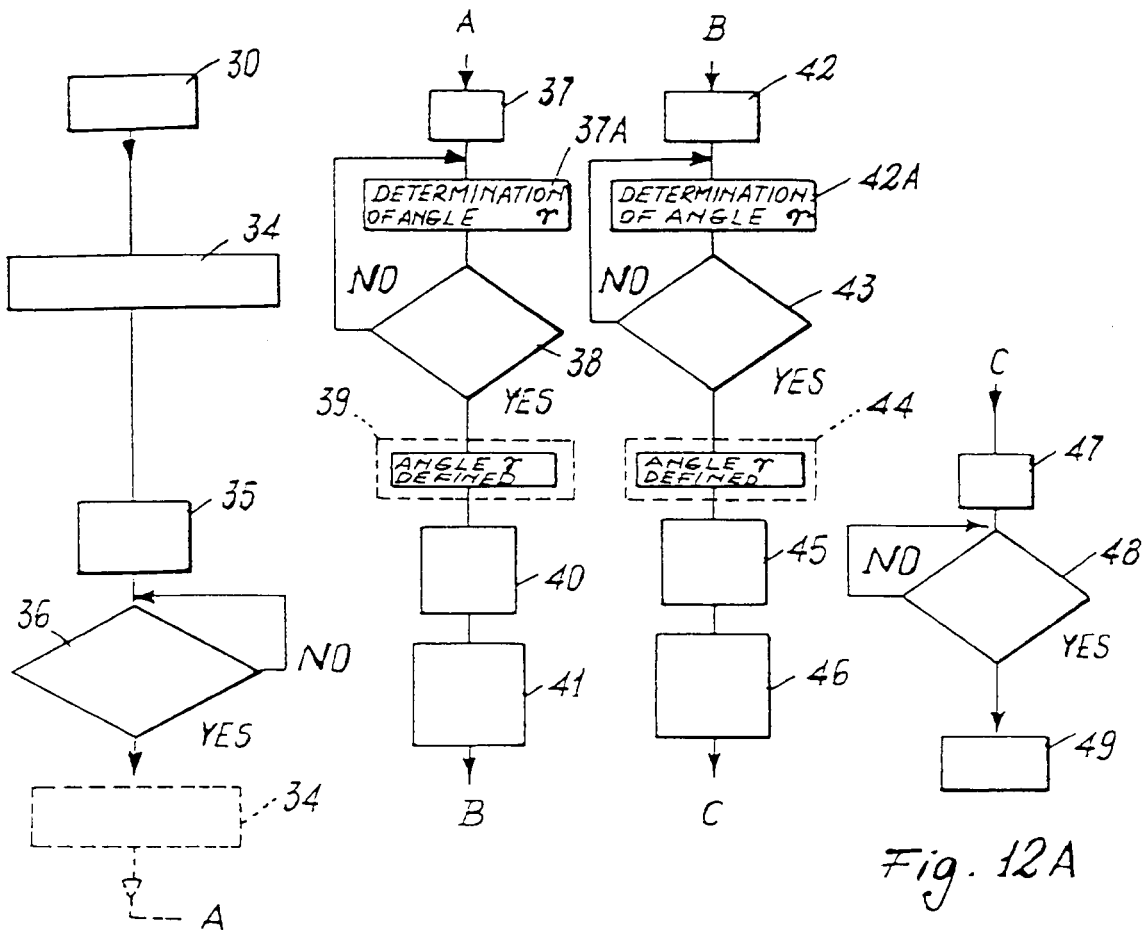

Fig. 12A

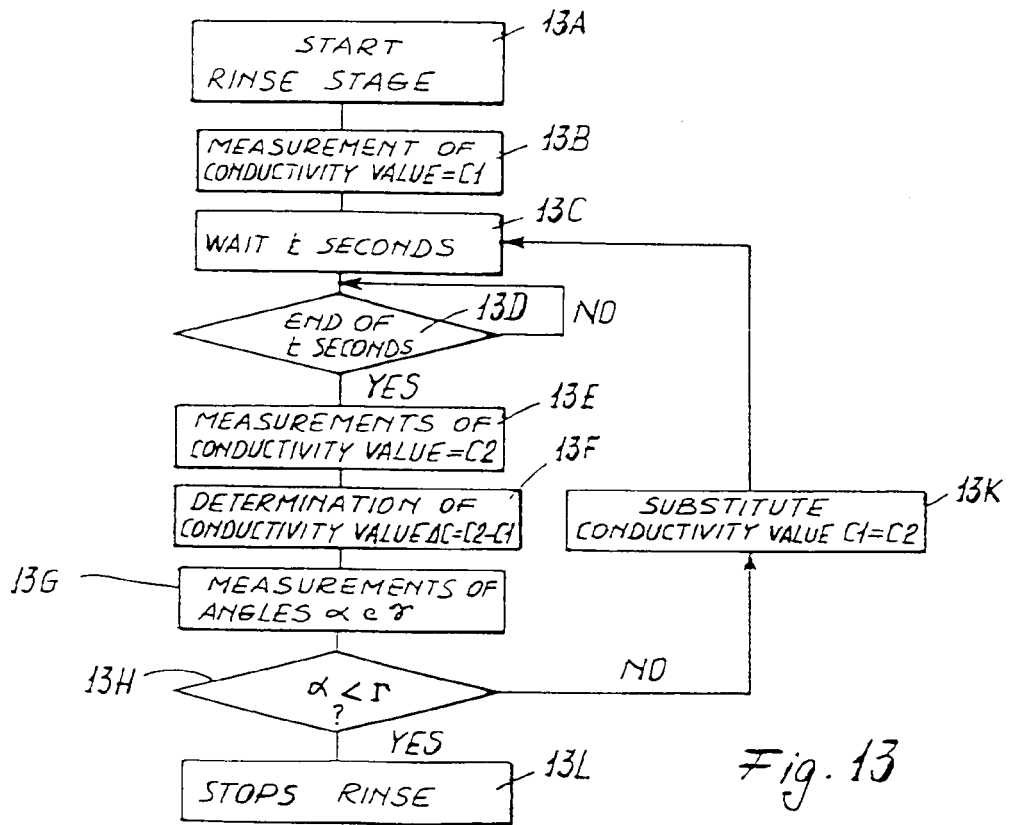

Fig. 13