



US 20100089935A1

(19) **United States**

(12) **Patent Application Publication**
HEILMAN et al.

(10) **Pub. No.: US 2010/0089935 A1**

(43) **Pub. Date: Apr. 15, 2010**

(54) **CONTAINER HAVING A LID THAT IS OPENABLE UPON APPLICATION OF A DOWNWARD FORCE**

(22) Filed: **Oct. 13, 2008**

Publication Classification

(76) Inventors: **LAURA LYNN HEILMAN,**
PETERSBURG, KY (US);
MICHAEL SEAN FARRELL,
TERRACE PARK, OH (US);
GERALD BOYD ZINNBAUER,
CORNELIUS, NC (US)

(51) **Int. Cl.**
B65D 43/14 (2006.01)
B65D 51/04 (2006.01)

(52) **U.S. Cl. 220/833; 220/810**

(57) **ABSTRACT**

A container having a base and a single-hinged lid. The base has one or more walls that define an interior volume and an opening that permits access to the interior volume. The single-hinged lid is movably attached to the base and the lid at least partially covers the opening in a closed state and permits a user access to the opening in an open state. The lid is transitionable from the closed state to an open state upon the user applying a net downward force to the lid that covers the opening.

Correspondence Address:
THE PROCTER & GAMBLE COMPANY
Global Legal Department - IP
Sycamore Building - 4th Floor, 299 East Sixth
Street
CINCINNATI, OH 45202 (US)

(21) Appl. No.: **12/250,091**

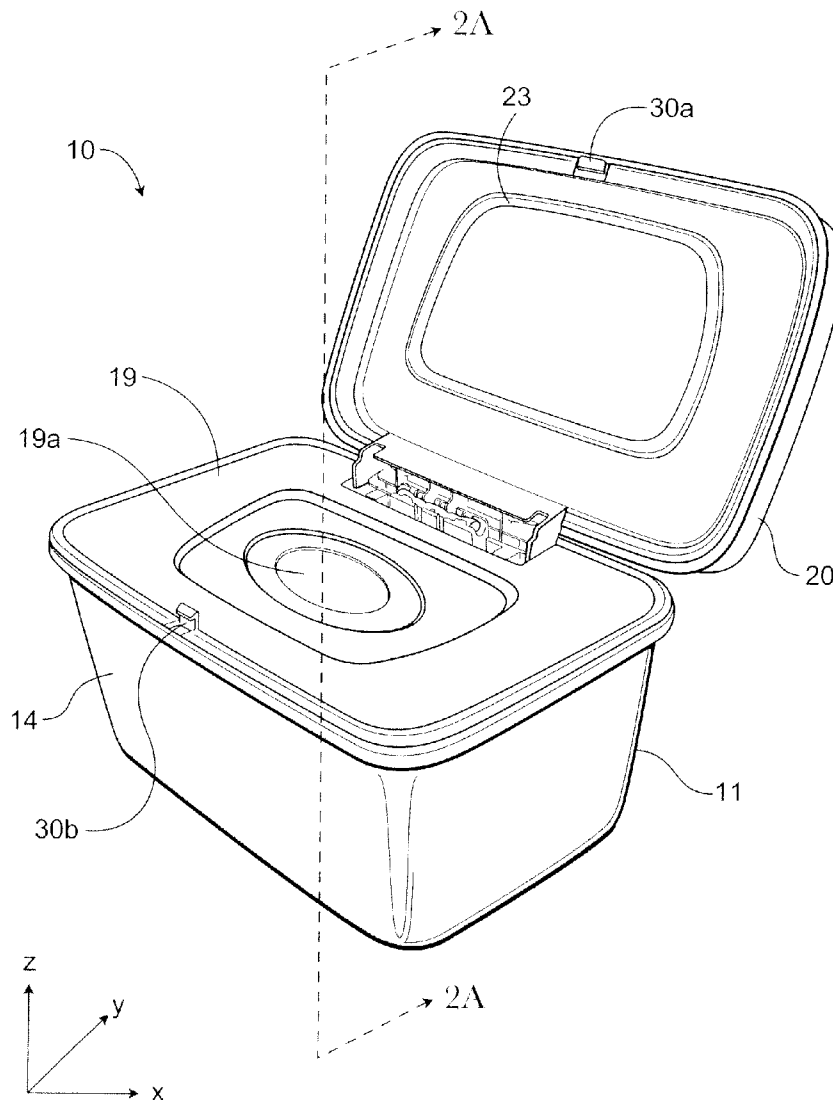

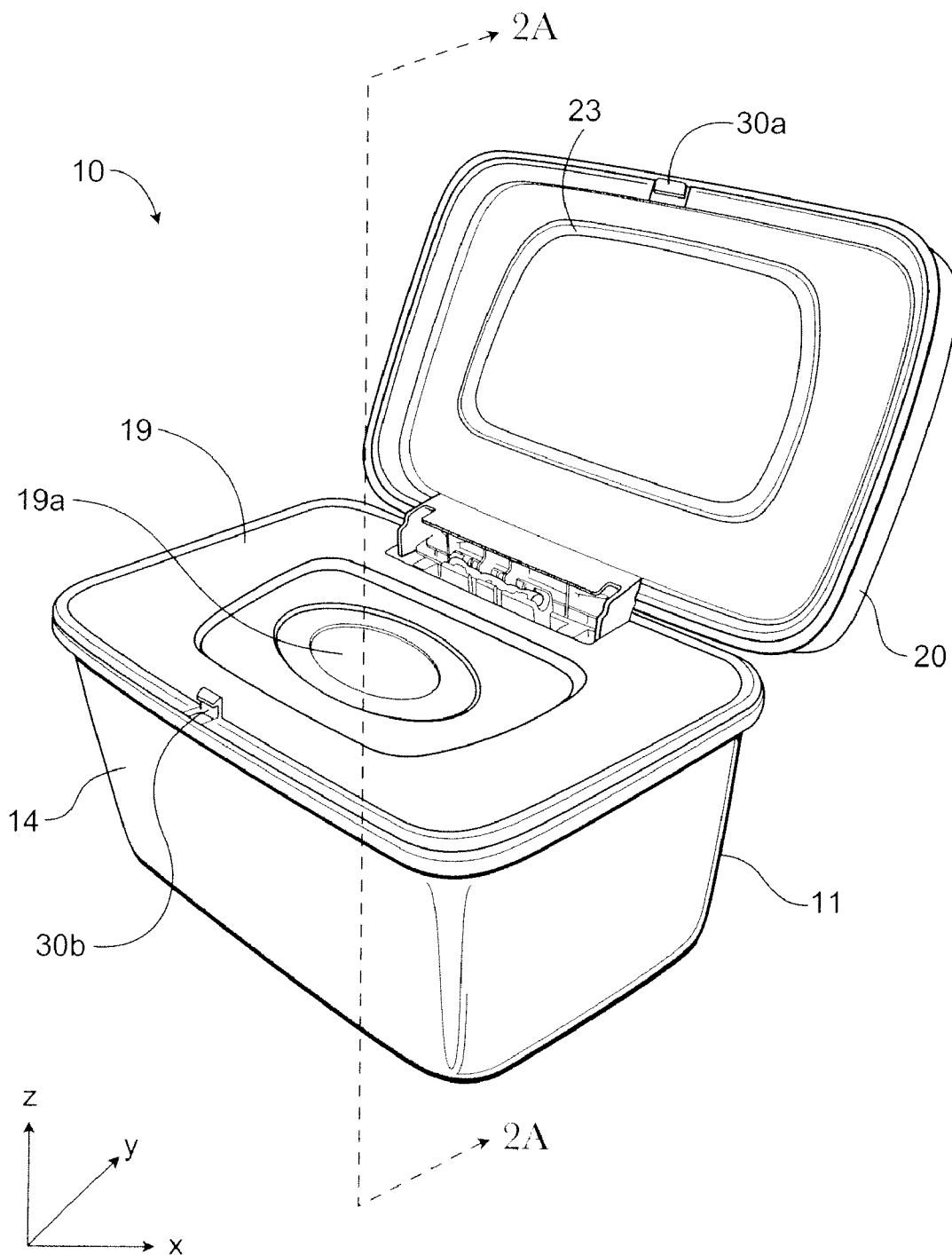

Fig. 1A

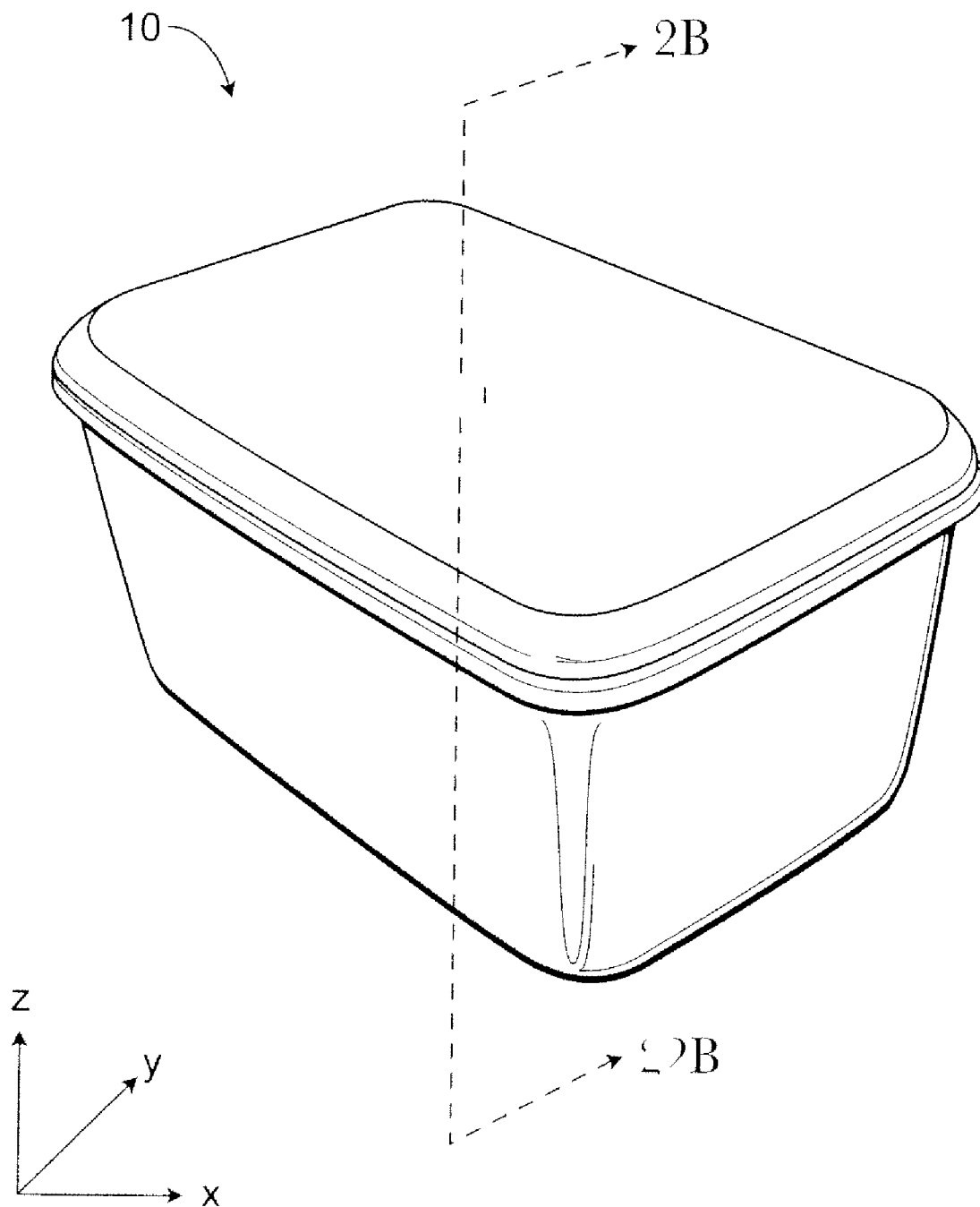

Fig. 1B.

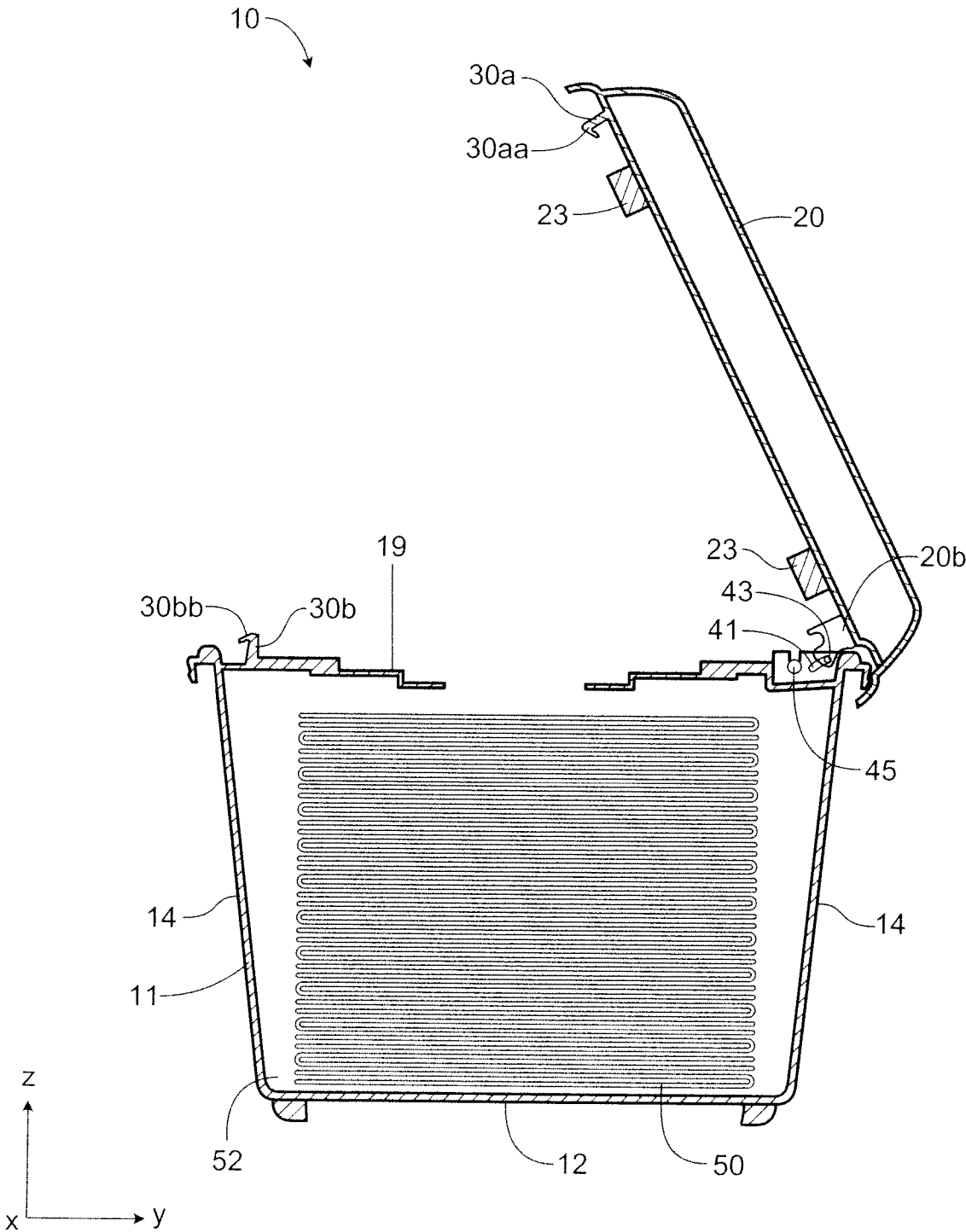

Fig. 2A

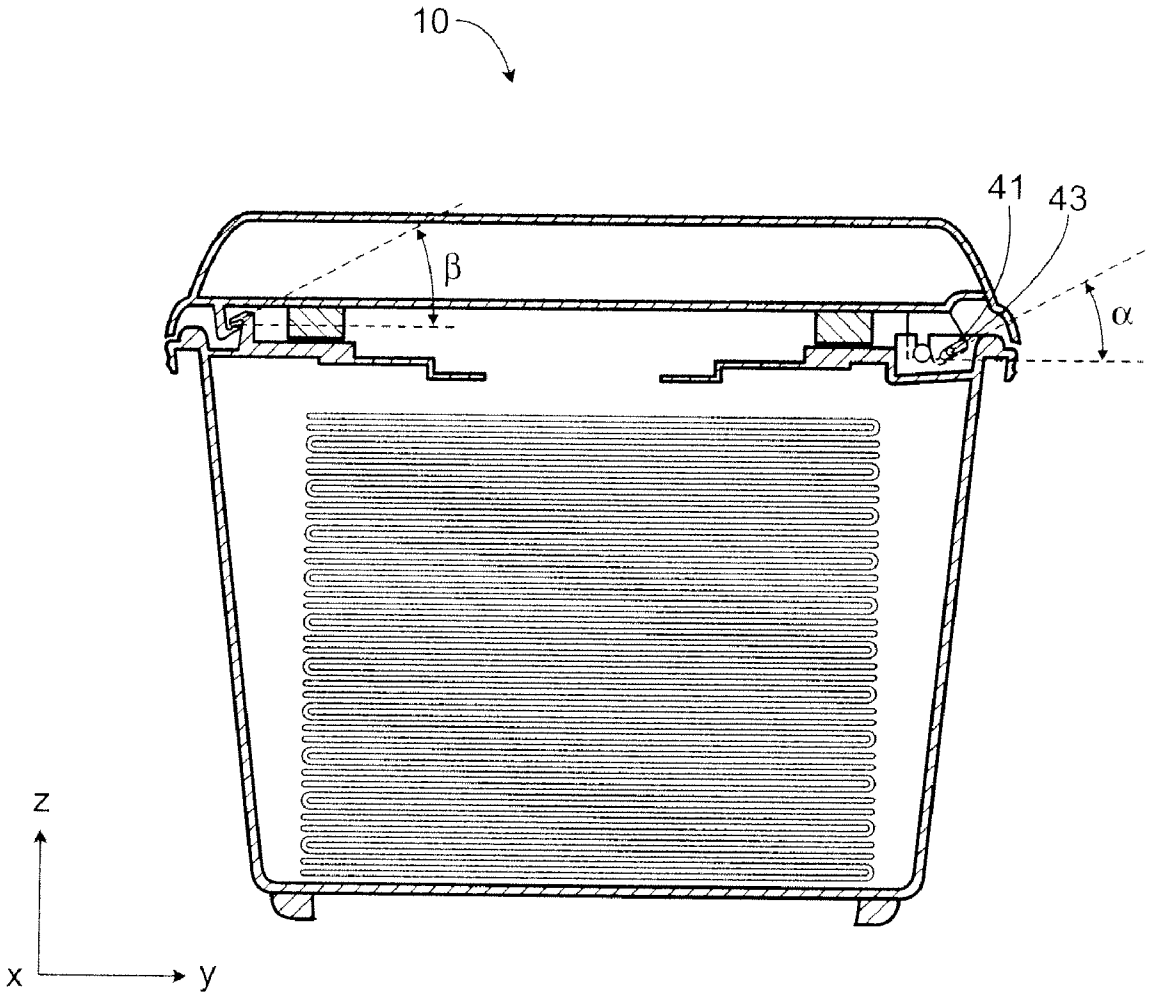

Fig. 2B

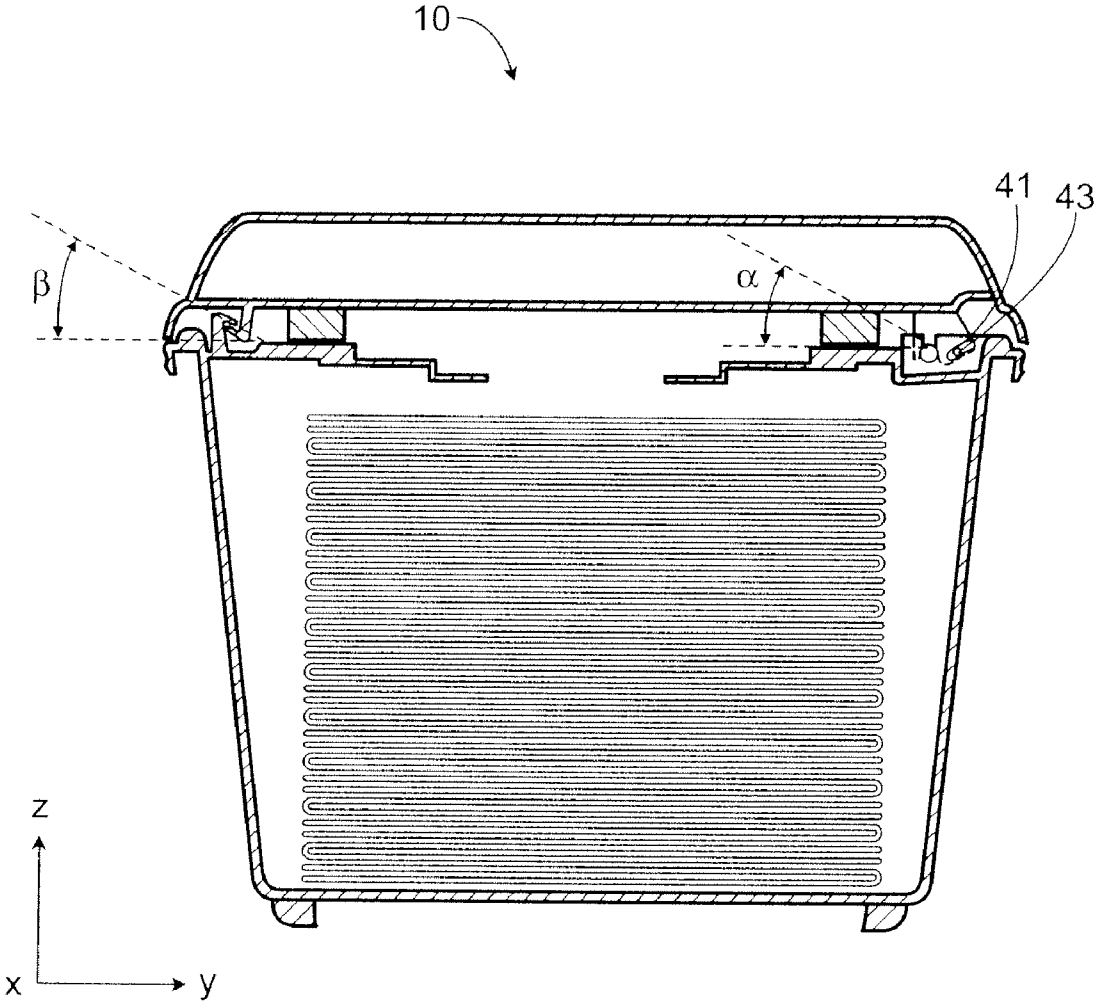

Fig. 2C

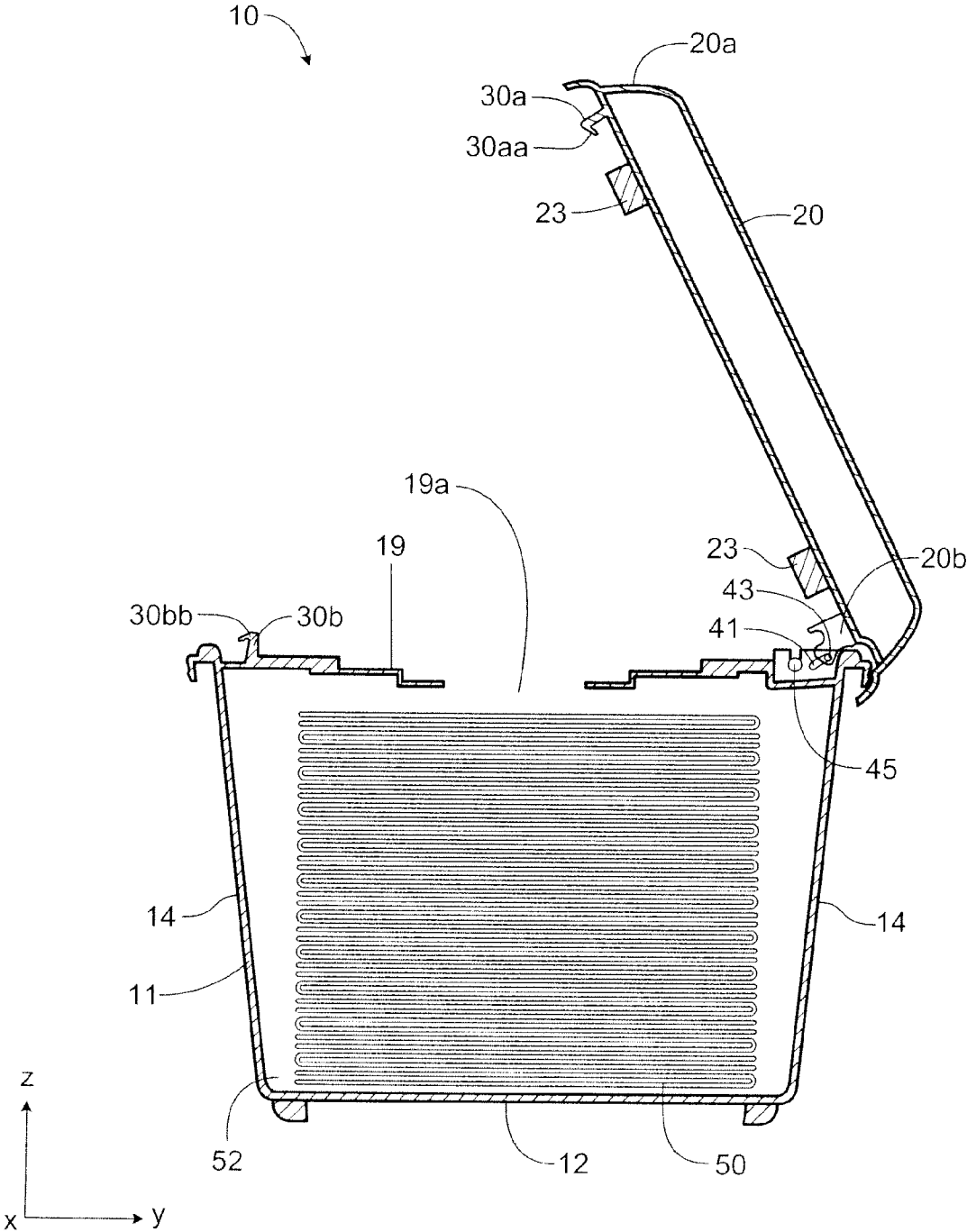

Fig. 3A

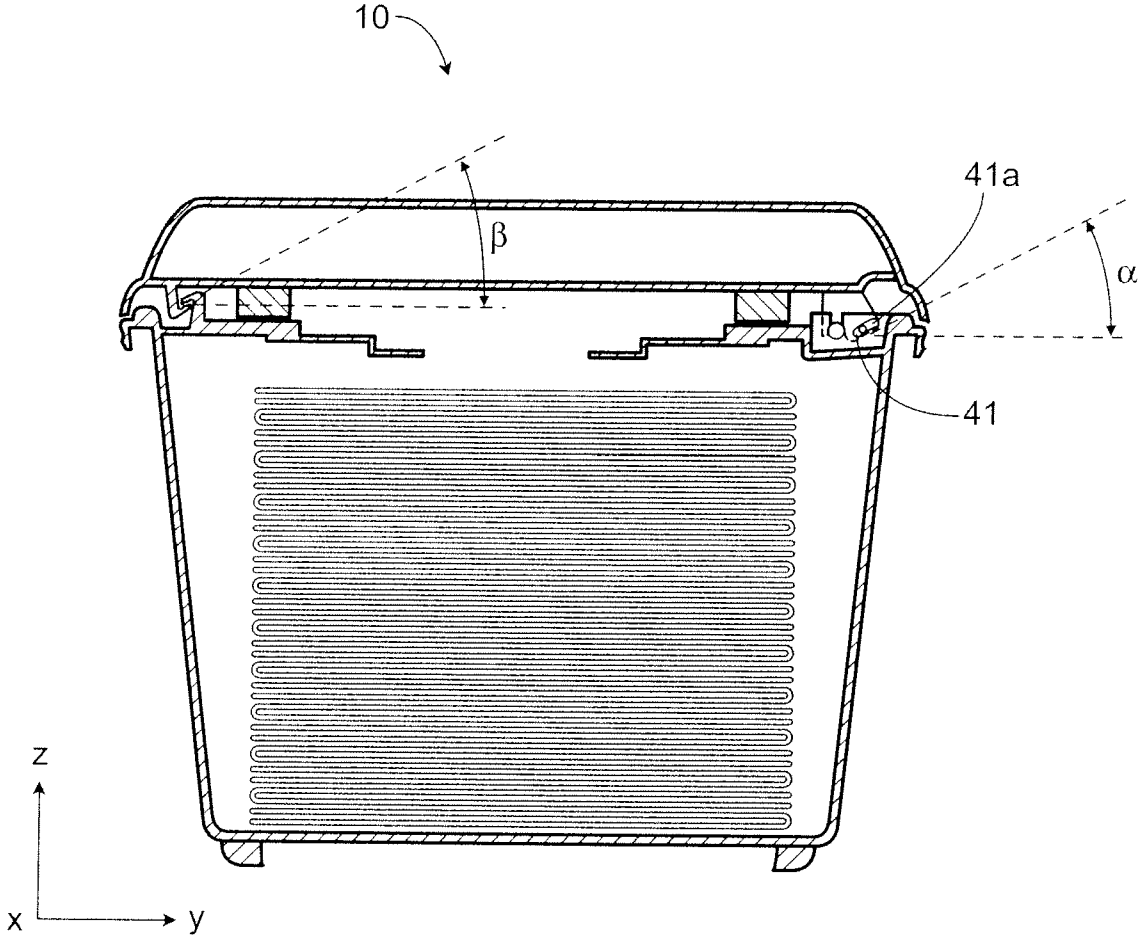

Fig. 3B

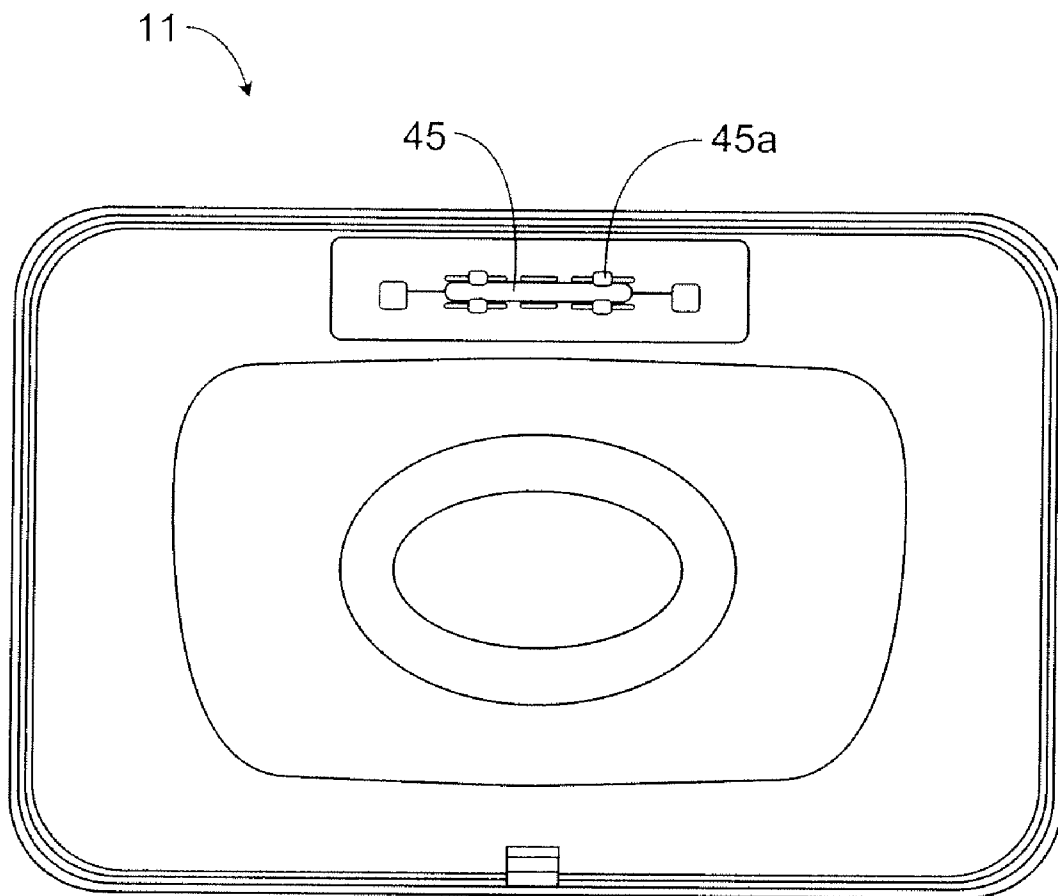

Fig. 4A

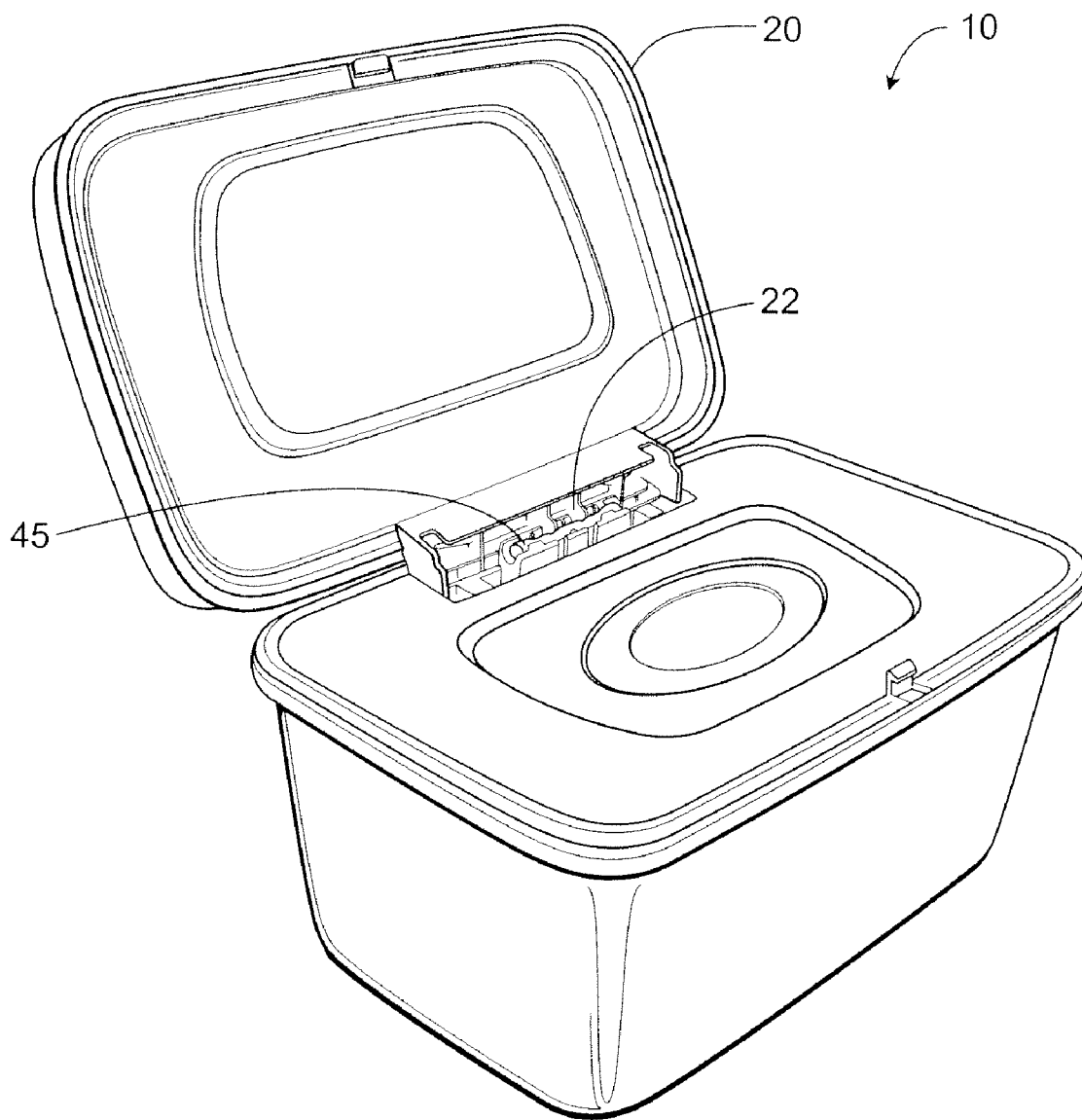

Fig. 4B

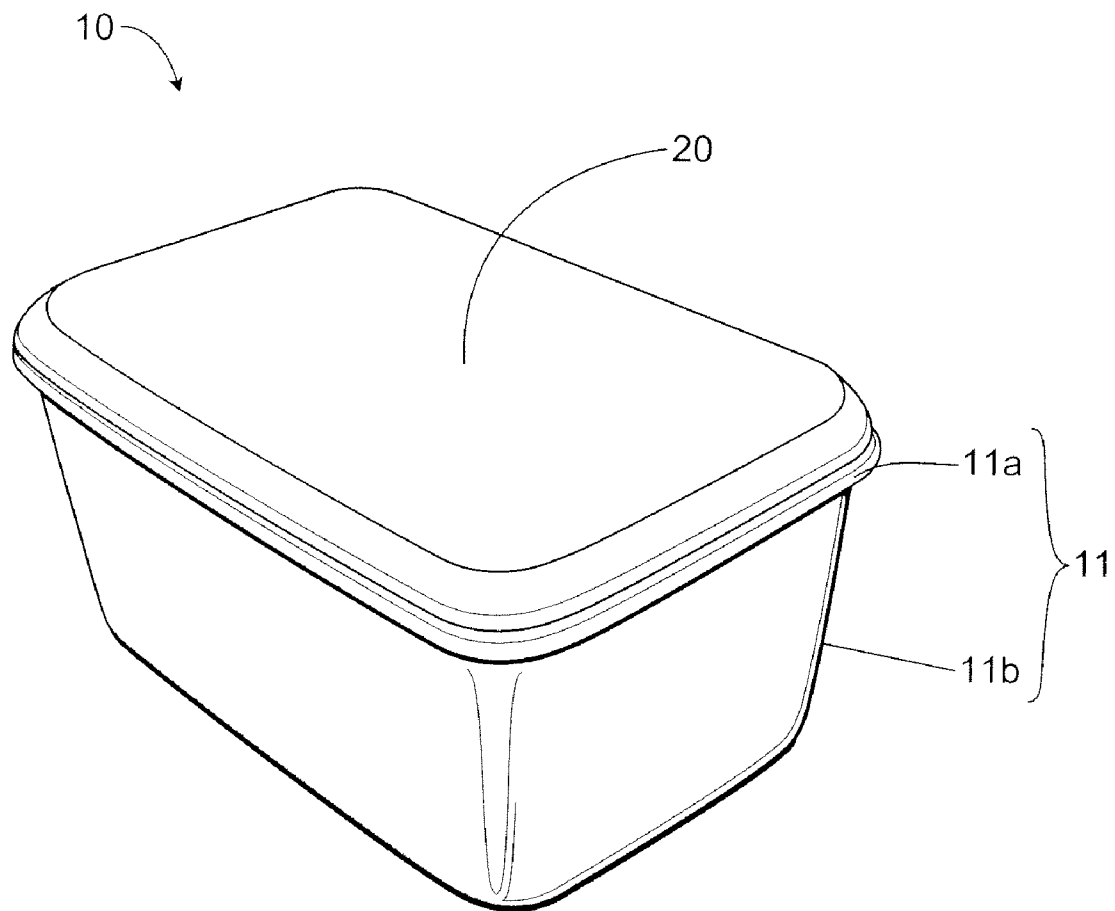

Fig. 5A

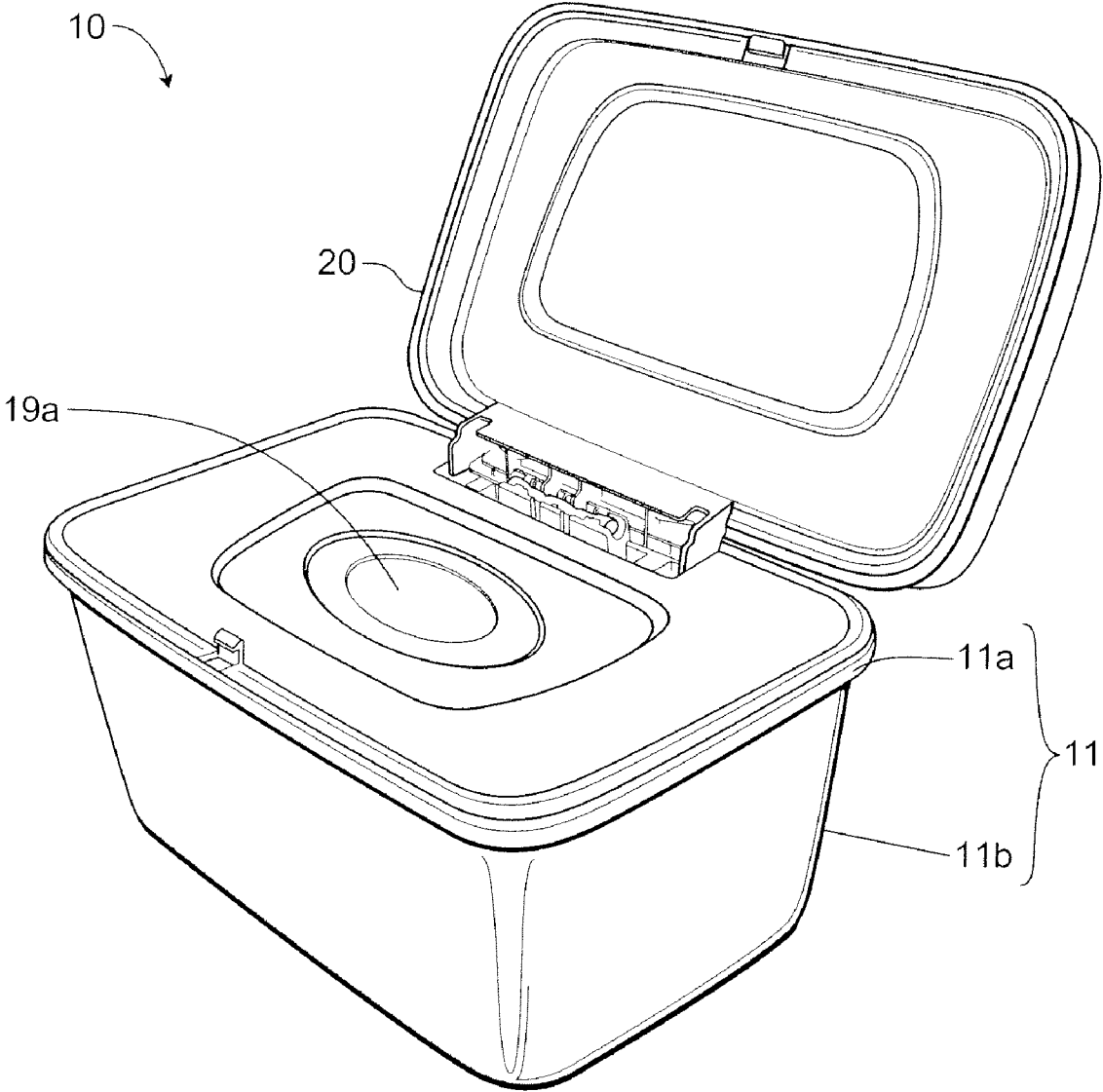

Fig. 5B

CONTAINER HAVING A LID THAT IS OPENABLE UPON APPLICATION OF A DOWNWARD FORCE

FIELD OF THE INVENTION

[0001] This invention relates generally to a container, and more specifically to a container that provides improved functionality by providing a product container having a lid that is openable upon application of a downward force.

BACKGROUND OF THE INVENTION

[0002] Product packaging, such as containers, boxes, and the like, are well known in the consumer products art. However, even with the large number of products which are sold and stored in packages, a number of problems with different packages still exist. For example, many packages have a lid that is either threaded, or that snaps into place. While such containers may provide exceptional sealing and closure properties, one disadvantage to such containers is that the container often requires two handed operation for successful opening and closing.

[0003] An alternative type of package that provides a high level of ease of opening is one which is “self opening.” In other words, a button or other mechanism may be depressed causing the top of the package to open. However, a number of challenges arise in the area of self-opening product packaging. Typically, a package which has an opening mechanism contains a number of components and/or parts—especially in the opening mechanism. Unfortunately, because each component used adds cost to the package, the more components used, the higher a package will cost—causing the overall price of a product to rise and possibly lose some competitive advantage to competitors’ products which may be packaged in more economical packaging. An alternative option to the multiple parts for an opening mechanism is to use a molding process that molds one or more additional materials to the initial part. One of skill in the art will appreciate that such a process may add to the complexity and cost of the mold and part, but can help improve the overall cost due to a simplified assembly processes. Furthermore, the use of a second material offers additional consumer benefit such as an actual and/or perceived seal when the same material is added to opening areas. While a seal may not be important for all products, a moisture barrier is especially helpful for a product such as a wet wipe product because such a product may lose its moisture content (i.e., dry out) if exposed for an extended period of time to the outside elements. Unfortunately, some products need a high level of ease of opening and cannot justify the added cost of the secondary mold process or the optional seal. Thus, it may be advantageous for a manufacturer of multiple product lines to produce multiple containers to meet financial needs of the individual product lines.

[0004] Some producers provide a package that may open upon application of a force to the top, rather than to a button, but such packages involve the use of multiple hinges. While such a container provides the benefit of relatively easy one-handed operation, from the consumer’s perspective, such a container tends to have a reduced-sized opening due to the multiple-hingedness of the lid. Thus, there exists the need for

a container that is relatively easy to open, is versatile, inexpensive to produce, providing easy product access, with a relatively sleek design.

SUMMARY OF THE INVENTION

[0005] In one embodiment the present invention is directed to a container comprising: (i) a base comprising one or more walls that define an interior volume and an opening that permits access to the interior volume; (ii) a single-hinged lid wherein the lid is movably attached to the base wherein the lid at least partially covers the opening in a closed state and permits a user access to the opening in an open state; wherein the lid is transitionable from the closed state to an open state upon the user applying a force to the lid that covers the opening.

[0006] In another embodiment the present invention is directed to a container comprising: (i) a base comprising one or more walls that define an interior volume and an opening that permits access to the interior volume; (ii) a lid, wherein the lid is movably attached to the base wherein the lid at least partially covers the opening in a closed state and permits a user access to the opening in an open state; wherein the lid is transitionable from the closed state to an open state upon the user applying a force to a portion of the lid that covers the opening.

[0007] In yet another embodiment the present invention is directed to a container comprising a (i) a base comprising a closed bottom, an open top, a body having an enclosed perimeter between the bottom and the top, a first locking mechanism, and one or more slots in the body wherein each of the one or more slots has a slide surface area; wherein the bottom, top, and body together define an interior volume; (ii) a lid comprising a second locking mechanism and a hinge wherein the hinge has a slide surface area; wherein the one or more slots extend around the hinge; wherein the slide surface area of the slots is greater than the slide surface area of the hinge; and wherein the first locking mechanism and second locking mechanism are matably engageable.

BRIEF DESCRIPTION OF THE DRAWINGS

[0008] FIG. 1A is a perspective view of an exemplary embodiment of a container according to the present invention in an open configuration.

[0009] FIG. 1B is a perspective view of an exemplary embodiment of a container according to the present invention in a closed configuration.

[0010] FIG. 2A is a cross-sectional view of an exemplary embodiment of the container according to FIG. 1A taken along line 2A-2A.

[0011] FIG. 2B is a cross-sectional view of an exemplary embodiment of the container according to FIG. 1B taken along line 2B-2B.

[0012] FIG. 2C is a cross sectional view of an alternative embodiment of the container according to FIG. 1A taken along line 2A-2A.

[0013] FIG. 3A is a cross-sectional view of an exemplary embodiment of the container according to FIG. 1A taken along line 3A-3A.

[0014] FIG. 3B is a cross-sectional view of an exemplary embodiment of the container according to FIG. 1B taken along line 3B-3B.

[0015] FIG. 2A is a cross-sectional view of an exemplary embodiment of the container according to FIG. 1A taken along line 2A-2A.

[0016] FIG. 4 is a top view of an exemplary embodiment of a base according to the present invention.

[0017] FIG. 5A is a perspective view of an exemplary embodiment of a container according to the present invention in a closed configuration.

[0018] FIG. 5B is a perspective view of an exemplary embodiment of a container according to the present invention in an open configuration.

DETAILED DESCRIPTION

Definitions

[0019] “Container”, as used herein, refers to any package, box, holder, vessel, envelope, carton, and the like in which at least a portion of a product can be placed for shipping, transport, storage and/or sale. A container may be any shape or size that is required for the desired function or product and may be, for example, round, square, rectangular. Exemplary containers are disclosed in U.S. Pat. Nos. 6,401,968, 6,523,690 and 5,785,179 and in U.S. Pat. App. Pub. Nos. 2008/0099596A1 and 2005/0067313A1. In one embodiment, the container is constructed from a thermal plastic elastomer (TPE) material or from a polyethylene or polypropylene resin. In another embodiment the lid and/or body may be molded from a polypropylene material or any other suitable thermoplastic material such as polyethylene, polystyrene, acrylonitril butadiene styrene (ABS), polyester, polyvinyl chloride, polycarbonate, or elastomer, or a blend of these compounds. Alternatively, a container may be made from another material such as wood, metal, or glass. In one embodiment, a container comprises a base and a lid. One of skill in the art will appreciate that the lid and base may be constructed from the same, or different, materials. In one embodiment a container of the present invention may be operated (i.e., opened and/or closed) by applying a force to the lid-portion of the container. In another embodiment, the force is a non-twisting force. In yet another embodiment still, the force is a net downward force. This configuration may be compared to many containers in which a button attached to the body is depressed to operate the container. Exemplary embodiments of such containers are described in U.S. Pat. App. Pub. Nos. 2007/0278229A1, 2008/0128451A1 and 2006/0096984A1.

[0020] “Base”, as used herein, refers to a portion of the container which forms the body of the container. In one embodiment, a base is comprised of a front panel, rear panel, bottom panel, and side panels. In another embodiment, a base comprises a closed bottom, an open top, a body having an enclosed perimeter between the bottom and the top, a first locking mechanism, and one or more slots in the body wherein each of the one or more slots has a slide surface area. In yet another embodiment the base comprises one or more walls that define an interior volume and an opening that permits access to the interior volume. In some embodiments a base of the present invention may comprise a cavity between the panels in which product may be stored.

[0021] “Lid”, as used herein, refers to a portion of the container which forms the top and/or cover section of the container. A container having a lid and a base may be configured such that the lid is relative to a base in a way that the container may be in an open configuration or in a closed configuration. In one embodiment a lid may be depressed (or

otherwise have some force exerted thereon) to cause the container to go from a closed state to an open state. A lid may be single-hinged. In other words, a lid may have one hinge attached thereto. Such a lid may be compared to, and distinguished from, a double-hinged lid in which a lid has more than one hinge attached (or integral) thereto. Such an exemplary double-hinged lid is described in U.S. Pat. No. 6,732,873.

[0022] “Product”, as used herein, refers to any object, material or substance that is intended for use by a consumer. In some nonlimiting embodiments, a product may be selected from the group consisting of wipes, napkins, facial tissues, bathroom tissue, paper towels, baby care products, feminine care products, household care products, personal care products, and combinations thereof. Products are described in greater detail infra.

[0023] “Disposed on”, as used herein, refers to the placement or position of one element relative to another element, where the elements are connected to or in physical contact with one another. For example, when a first element is disposed on a second element, the first and second elements may be joined together or formed together to provide an integral or unitary article. A first element may also be disposed on a second element when the first element is applied to the second element, for example, by a printing method or a coating method.

[0024] “Moisture impermeable”, as used herein, means that an element resists and, ideally, prevents the passage of liquid and/or gaseous compositions (e.g., water and/or water vapor) from one side of the element to the opposing side of the element. For example, a wipes container for storing wet wipes will typically include one or more walls that resist the passage and/or penetration of liquid water and water vapor through the wall of the wipes container in order to prevent or at least delay moisture loss from the wet wipes. Thus, the walls of the container are said to be moisture impermeable.

[0025] “Wipe”, as used herein, refers a fibrous substrate, for example a nonwoven, used for cleaning skin and other surfaces. “Wet-wipe” refers to a wipe that includes more than 10% of a liquid composition by weight of the wet-wipe. The liquid composition may be impregnated into the wipe or the liquid composition may be fugitive (i.e., free to move from one portion of the wet wipe to another portion).

[0026] “Substrate”, as used herein, refers to the underlying material of which an element or component is made. In a 2-layer laminate structure, for example, each layer of the laminate may include the same or different materials, which materials may both be substrates. However, it is to be understood that in certain embodiments only the base layer of the laminate may be referred to as the substrate. Additionally, the laminate itself may also be a substrate for use in forming yet another component.

[0027] “Nonwoven”, as used herein, refers to a porous, fibrous structure made from an assembly of continuous fibers, coextruded fibers, noncontinuous fibers or combinations thereof, without weaving, knitting, or felting. Non-limiting examples of suitable processes for making a nonwoven include spunbonding, carding, meltblowing, air laying, wet laying, coform, and the like. The nonwoven structure may comprise one or more layers of such fibrous assemblies, wherein each layer may include continuous fibers, coextruded fibers, noncontinuous fibers and combinations thereof.

[0028] “Elastic member”, as used herein, refers to a component of a package or container which is capable of substan-

tially recovering size and shape after deformation. In one embodiment, when used in a container of the present invention an elastic member may be used to provide a resistive force to one or more components of the container. In another embodiment, an elastic member may be used to provide a resistive force between components of the container. For example, an elastic member may be used to provide a resistive force to the lid. In one embodiment, an elastic member may be rubber, silicone, TPE, or some other polymeric material. In another embodiment, an elastic member may be a spring.

[0029] “Slideably engageable”, as used herein, refers to the ability of two or more components to be engaged in a mating arrangement by sliding one component along another component.

Container

[0030] FIG. 1A shows an exemplary embodiment of a container 10 according to the present invention in an open configuration. In the exemplary embodiment, the container 10 may include a base 11. The base 11 comprises a bottom 12, a top 19, and a body 14 having an enclosed perimeter between the bottom 12 and the top 19. Put another way, the base 11 comprises one or more walls that define an interior volume. The top 19 of the base 11 may optionally comprise an opening 19a through which any product may be extracted from, or placed into, the container 10. The exemplary container 10 of FIG. 1A also includes a lid 20 hingedly and/or movably connected to the body of the base 11. In one embodiment the lid 20 is a single-hinged lid that at least partially covers the opening 19a when the container 10 is in a closed state and permits a user access to the opening 19a when the container 10 is in an open state. In the embodiment shown in FIG. 1A, the lid 20 is attached to the base 11 by a single hinge to any suitable part of the base 11 and the lid is a unitary member. That is, the lid 20 does not comprise an additional hinge. In another embodiment, the lid is transitionable from the closed state to an open state upon the user applying a force to a portion of the lid 20 that covers the opening 19a.

[0031] Access to the interior volume may be beneficial so that a consumer may access product(s) disposed therein. For example, such a container 10 may hold a wipes product and when a supply of wipes is depleted within the container 10, the container 10 may be refilled with replacement wipes.

[0032] The exemplary container 10 may also comprise a first locking mechanism 30a and a second locking mechanism 30b. The first locking mechanism 30a may be attached to, and may extend from, the base 11. The second locking mechanism 30b may be attached to, and may extend from, the lid 20. The first and second locking mechanisms 30a, 30b may be juxtaposed such that they are slideably engageable to secure the container 10 in a “closed” state (i.e., the lid 20 and base 11 overlap) (FIG. 1B). Additionally, the first and second locking mechanisms 30a, 30b are slideably disengageable to allow the container to transition from a “closed” state (FIG. 1B) to an “open” state (FIG. 1A).

[0033] The exemplary container 10 may also optionally comprise a sealing member 23. The container may be used to provide a means for storage and dispensing of wet wipes products, or some other product with relatively high moisture content. In such an instance, by providing a compressible polymeric member 23 around the opening 19a through which product may be extracted will improve the retention of moisture of such a wet wipes product.

[0034] FIG. 2A is a cross-sectional view of the exemplary container 10 of FIG. 1A taken along line 2A-2A. In the embodiment shown in FIG. 2A, the container 10 includes a base 11 having a bottom 12, a top 19, and a body 14 having an enclosed perimeter between the bottom 12 and the top 19. The top 19 further comprises an opening 19a wherein a consumer may access the product 50 disposed in the base cavity 52 of the container 10. The base 11 includes one or more hinges 43 extending therefrom. The lid 20 may be hingedly connected to the base 11. In the exemplary embodiment, the lid 20 comprises one or more extending slots 41. In the exemplary embodiment the one or more extending slots 41 may extend around the one or more hinges 43. In one embodiment a slot 41 further comprises a locking nub 41a. In some embodiments a locking nub 41a may provide stability to the lid as it opens. In particular, the locking nub 41a may hold the lid in place so that the locking mechanisms 30a, 30b may be more easily separated before the elastic member pulls the lid back to the closed position. In other words, this locking nub 41a may give the locking mechanisms 30a, 30b time to start vertical or rotational motion to clear each other. The first and second locking mechanisms 30a, 30b may extend from any area of the base 11 and/or lid 20 (respectively) that may be suitable for allowing the locking mechanisms to matably engage.

[0035] Both the slots 41 and hinges 43 have a so-called slide surface area. In the case of a slot 41, the slide surface area of the slot 41 is the surface area of the opening in the same plane as the wall the slot 41 is in. For example, in the embodiment shown in FIG. 2A, the slide surface area of the slot is measured as the surface area the slot 41 (or the hinge 43) occupies in the y-z plane. In the case of a hinge, the slide surface area is the surface area of the hinge 43 is the area measured in the y-z plane (as shown in FIG. 2A). In other words, the slide surface area of the hinge 43 is the area of the cross-section of the hinge, the cross section taken along the axis of the hinge 43. In one embodiment, a slot 41 may have a slide surface area that is larger than the slide surface area of a corresponding hinge 43.

[0036] Comparing the ratio of the slide surface area of the hinge 43 and the slide surface area of the slot 41 may be an efficient way to describe the distance that the hinge must travel relative to the slot and/or size of the hinge regardless of the size and/or shape of the slot. By providing a slot 41 with a slide surface area greater than the slide surface area of the corresponding hinge 43, the lid 20 will be slideable relative to the slot 41. In one embodiment the slot 41 has a surface area of from 1.1 to about 50 times the slide surface area of the hinge 43. In another embodiment, the slot 41 has a slide surface area of from about 1.1 to about 25 times the slide surface area of the hinge 43.

[0037] In one embodiment the container 10 further comprises an elastic member 45 which may provide a resistive force to the lid 20. In the exemplary embodiment, the lid 20 may be moved and/or slid and/or rotated and/or pivoted relative to the hinge 43. In one embodiment the lid 20 comprises a slot 41 which may be juxtaposed at an angle α or be configured such that the hinge 43 may move relative to the slot 41 at an angle α . One of skill in the art will appreciate the fact that α depends on the relative direction which the slot will move relative to the hinge. This is exemplified in FIG. 2C wherein the slot 41 is sloping in the opposite direction compared to the slot in FIG. 2A, but α is the same measurement in both embodiments. By convention α is measured as the smallest

angle relative to the x-axis. In another embodiment α is from about 10° to about 80° . In still another embodiment α is from about 20° to about 40° .

[0038] In a particular embodiment the first and second locking mechanisms **30a**, **30b** comprise first and second tabs **30aa**, **30bb** (respectively) which provide a means for mechanical mating engagement of the first and second tabs **30a**, **30b**. In one embodiment the locking mechanisms **30a**, **30b** and tabs **30aa**, **30bb** are juxtaposed such that the tabs engage at an angle β . In one embodiment β is from about 10° to about 80° . In another embodiment still, β is from about 20° to about 40° . By providing β such that β is similar to α (i.e., $\alpha \approx \beta$ or $\alpha = \beta$) or in another embodiment wherein $\alpha > \beta$ the lid will engage/disengage with relative ease upon application of force to the lid because the lid will move along the hinge **43** resulting in the first locking mechanism **30a** sliding relative to the second locking mechanism **30b**. Once the locking mechanisms **30a**, **30b** are no longer in contact, the elastic member **45** provides resistance against the lid **20**, causing the lid **20** to open. In one embodiment the length of the tabs **30aa**, **30bb** and the length of the slot **41** are about the same or are relatively similar. In another embodiment the length of the tabs **30aa**, **30bb** (in one embodiment, the length by which the tabs engage) is less than the length of the slot. The hinge may slide a distance that is greater than the length by which the locking mechanisms **30a**, **30b** engage to provide for relatively efficient opening and closing. By providing such dimensions, the container lid will be relatively easy to engage/disengage.

[0039] In one embodiment, a force may be applied to the lid **20** when the container **10** is in an open configuration in order to close the container **10**. The lid **20** may be pushed such that the lid **20** rotates about the hinge **43** and the first and second locking mechanisms **30a**, **30b** are brought into contacting engagement. Upon continued application of force to the lid **20**, the lid **20** will slide the slot **41** about the hinge and the lid **20** will engage with the elastic member **45**. As the lid moves along the slot **41** about the hinge **43**, the first and second locking mechanisms **30a**, **30b** are in sliding engagement until the first tab **30aa** passes the end of the second tab **30bb** and the elastic member **45** exerts a resistive force against the lid **20** which may cause the lid **20** to move back and subsequently provide engagement between the first and second locking mechanisms **30a**, **30b**.

[0040] FIG. 2B shows an exemplary embodiment of a cross-sectional view of the container of FIG. 1B taken along line 2B-2B. The configuration of parts in the embodiment of FIG. 2B is as described in FIG. 2A.

[0041] FIG. 3A is an exemplary alternative embodiment of a cross sectional view of the container **10** of FIG. 1A taken along line 3A-3A. In the embodiment shown in FIG. 3A, the container **10** includes a base **11** comprising a bottom **12**, a top **19**, and a body **14** having an enclosed perimeter between the bottom **12** and the top **19**. The exemplary container **10** of FIG. 1A also includes a lid **20** hingedly connected to the body **14** of the base **11**. The top **19** of the base **11** may optionally comprise an opening **19a** through which any product may be extracted from, or placed into, the container **10**. The base **11** includes one or more slots **41** provided therein. In the exemplary alternative embodiment, the lid **20** comprises one or more hinges **43** and the one or more extending slots **41** may extend around the one or more hinges **43**.

[0042] FIG. 3B shows an exemplary embodiment of a cross-sectional view of the container of FIG. 1B taken along

line 3B-3B. The configuration of parts in the embodiment of FIG. 3B is as described in FIG. 3A.

[0043] Surprisingly, it was found that by providing a container as exemplified supra, a user could open the container with relative ease by simply applying a force to the lid.

[0044] The container may be constructed of any material suitable for the product being contained by the container. In one embodiment the container is constructed from a moisture impermeable material, such as a polymeric material. In one embodiment, the container is constructed from a thermoplastic resin such as a polyethylene or polypropylene resin. In another embodiment the lid and/or body may be molded from a polypropylene material or any other suitable thermoplastic material such as polyethylene, polystyrene, acrylonitril butadiene styrene (ABS), polyester, polyvinyl chloride, polycarbonate, or elastomer, or a blend of these compounds.

Elastic Member

[0045] FIG. 4A shows an overhead view of an exemplary embodiment of a base **11** according to the present invention. In the exemplary embodiment the elastic member **45** is supported by a plurality of elastic member supporting members **45a** which may be attached to, or extending from, any suitable portion of the base **11**. FIG. 4B shows a perspective view of an exemplary container **10** comprising an elastic member **45**. The lid **20** further comprises a hooking mechanism **22** wherein the hooking mechanism **22** engages with the elastic member **45**. The embodiment of FIG. 4B is particularly efficient because by positioning the elastic member **45** near the hinges, a relatively low amount of force will be required to open the lid **20**.

Base: Alternative "Easy Loading" Embodiment

[0046] FIG. 5A shows a perspective view of an exemplary embodiment of a container **10** having a base **11** wherein the base **11** comprises a first section **11a** and a second section **11b**, the intersection at which is partially and/or totally separable and/or openable. FIG. 5A shows the base in a closed configuration. FIG. 5B shows the base **11** in an open configuration. By providing such an embodiment, referred to as a "lid in a lid" embodiment, it may be relatively easier and/or faster for the container **10** to be loaded with a product. In the exemplary embodiment, once the product is loaded, the lid **20** may be closed and product may be accessed through an opening **19a** by opening and closing the lid **20**. In one embodiment, a base may have multiple and/or movable sections.

Sealing Member

[0047] In some embodiments the present invention container may include a sealing member of the present invention may be of any shape. In one embodiment, the sealing member may be annular such that it surrounds an opening in the top panel of the container. The sealing member may be made of any suitable material. In one embodiment, the sealing member may have relatively good elastic properties and resistance to volatile solvents, in one embodiment the sealing member is made of a rubber-based material or of some polymeric material. In another embodiment the sealing member may be a silicon gasket.

[0048] In one embodiment, a sealing member may be obtained by mixing a curable liquid form organopolysiloxane and a liquid form silicon based cross-linker curing agent. One of skill in the art may appreciate that the cure chemistry of the

silicon gasket is a condensation reaction of OH-terminated poly-alkyl-siloxanes with functional poly-alkoxy-silanes. A catalyst may be used to facilitate such reactions. In yet another embodiment the sealing member may be applied as a pre-formed, solid component which may be fit and/or mated to the lid.

[0049] In still another embodiment, a sealing member may be constructed from a TPE or TPR material. This embodiment may be useful because the sealing member is constructed from the same molding technology as the container.

Product

[0050] In one embodiment, a container of the present invention may be used to hold any product or good that may be desired. For example, a present invention container may be used to hold paper products. Exemplary paper products may be selected from the group consisting of: paper towels, facial tissues, bathroom tissue, cleaning cloths, lens cloths, low-lint cloths, sanitary tissue products, wet wipes, wipes, the like, and combinations thereof.

[0051] In another nonlimiting embodiment, a container of the present invention may be used to hold product selected from the group consisting of: household cleaners, laundry tablets, dish tablets, deodorizers, combinations thereof, and the like. In yet another nonlimiting embodiment, a container of the present invention may be used to hold product selected from the group consisting of: foodstuffs, candy, vitamins, the like, and combinations thereof. In still another nonlimiting embodiment, a container of the present invention may be used to hold hardware, bolts, screws, tools, the like, and combinations thereof. In some embodiments, a product as envisioned by the present invention excludes waste products and/or waste materials.

Product: Wipes

[0052] In some nonlimiting embodiments, the products used with a container of the present invention may be wipes. Commonly known consumer wipes, such as dry or pre-moistened wipes may be disposable and/or dispersible and/or flushable. In another embodiment the products may be wet wipes. Various different types of disposable wiping products such as, for example, wipes, facial tissues, bath tissues, paper towels, and napkins are commonly used by consumers. Such wiping products can include dry products or saturated or pre-moistened wiping products. Saturated or pre-moistened wiping products are used in a variety of different wiping and polishing applications. Pre-moistened wipes are commonly sold in a stack of individual, folded sheets packaged in a plastic container for use as baby wipes. In other applications, the wipes are treated with an antibacterial agent and packaged as a sanitary wiper. Whether the wiping products are wet or dry, it may be desirable to provide a container for storing and dispensing the wiping products. Such wipes may also include articles used for application of substances to the body, including but not limited to application of make-up, skin conditioners, ointments, medications and mixtures thereof. Such wipes may also include articles used for the cleaning or grooming of pets, and articles used for the general cleansing of surfaces and objects, such as household kitchen and bathroom surfaces, eyeglasses, exercise and athletic equipment, automotive surfaces and the like. Such wipes may also be used in the hospital or clinical environment to clean up bodily fluids and the like.

[0053] The wipes products may comprise man-made fibers, natural fibers and combinations thereof, and may or may not be biodegradable. Nonlimiting examples of man-made fibers include: rayon, which in turn includes but is not limited to viscose, lyocell and mixtures thereof; polyhydroxyalkanoates; polylactic acid; polyester; and mixtures thereof. Non-limiting examples of natural fibers include: pulp, cotton, wool, silk, jute, linen, ramie, hemp, flax, camel hair, kenaf, and mixtures thereof. Non-thermoplastic fibers that are of use in the present invention are selected from the group consisting of: rayon, which in turn includes but is not limited to viscose, lyocell and mixtures thereof; pulp; cotton; wool; silk; jute; linen; ramie; hemp; flax; camel hair; kenaf; and mixtures thereof.

[0054] The wipes may be folded and stacked in a common container such as a tub. The sanitary tissue products of the present invention may be folded in any of various known folding patterns, such as C-folding and Z-folding. Use of a Z-fold pattern may enable a folded stack of sanitary tissue products to be interleaved with overlapping portions. One of skill in the art will appreciate that any paper product, and not just wipes, may be folded as described and provided in a present invention container if it is so required.

[0055] The wipes of the present invention may further comprise a surface comprising a design, such as a surface pattern and/or prints, which may provide aesthetic appeal. Nonlimiting examples of prints include figures, patterns, letters, pictures and combinations thereof. Further, the sanitary tissue products may comprise emboss patterns and/or texture.

[0056] It is noted that terms like “specifically,” “preferably,” “typically,” “generally,” and “often” are not utilized herein to limit the scope of the claimed invention or to imply that certain features are critical, essential, or even important to the structure or function of the claimed invention. Rather, these terms are merely intended to highlight alternative or additional features that may or may not be utilized in a particular embodiment of the present invention. It is also noted that terms like “substantially” and “about” are utilized herein to represent the inherent degree of uncertainty that may be attributed to any quantitative comparison, value, measurement, or other representation.

[0057] The dimensions and values disclosed herein are not to be understood as being strictly limited to the exact numerical values recited. Instead, unless otherwise specified, each such dimension is intended to mean both the recited value and a functionally equivalent range surrounding that value. For example, a dimension disclosed as “40 mm” is intended to mean “about 40 mm”.

[0058] All documents cited in the Detailed Description of the Invention are, in relevant part, incorporated herein by reference; the citation of any document is not to be construed as an admission that it is prior art with respect to the present invention. To the extent that any meaning or definition of a term in this written document conflicts with any meaning or definition of the term in a document incorporated by reference, the meaning or definition assigned to the term in this written document shall govern.

[0059] While particular embodiments of the present invention have been illustrated and described, it would be obvious to those skilled in the art that various other changes and modifications can be made without departing from the spirit and scope of the invention. It is therefore intended to cover in the appended claims all such changes and modifications that are within the scope of this invention.

What is claimed is:

1. A container comprising:
 - (i) a base comprising one or more walls that define an interior volume and an opening that permits access to the interior volume; and
 - (ii) a lid having one hinge;
 - wherein the lid is movably attached to the base;
 - wherein the lid at least partially covers the opening in a closed state and permits a user access to the opening in an open state;
 - wherein the lid is transitionable from the closed state to an open state upon the user applying a net downward force to the lid.
2. A container according to claim 1 wherein the base further comprises one or more slots; and wherein the one or more slots extend around the hinge.
3. A container according to claim 2 wherein the one or more slots have a slide surface area and wherein the hinge has a slide surface area; wherein the slide surface area of the hinge.
4. A container according to claim 1 wherein the lid further comprises a sealing member.
5. A container according to claim 1 wherein the lid is a unitary element.
6. A container comprising:
 - (i) a base comprising one or more walls that define an interior volume and an opening that permits access to the interior volume; and
 - (ii) a lid;
 - wherein the lid is movably attached to the base;
 - wherein the lid at least partially covers the opening in a closed state and permits a user access to the opening in an open state;
 - wherein the lid is transitionable from the closed state to an open state upon the user applying a net downward force to a portion of the lid that covers the opening.
7. A container according to claim 6 wherein the lid further comprises a hinge.
8. A container according to claim 7 wherein the lid further comprises one or more slots; and wherein the one or more slots extend around the hinge.
9. A container according to claim 8 wherein the one or more slots have a slide surface area and wherein the hinge has a slide surface area; wherein the slide surface area of the hinge.
10. A container according to claim 6 wherein the lid further comprises a sealing member.
11. A container according to claim 6 wherein the lid is a unitary element.
12. A container according to claim 8 wherein the net downward force is non-twisting.
13. A container comprising:
 - (i) a base comprising a closed bottom, an open top, a body having an enclosed perimeter between the bottom and the top, a first locking mechanism, and one or more slots in the body, wherein each of the one or more slots has a slide surface area;
 - wherein the bottom, top, and body together define an interior volume; and
 - (ii) a lid comprising a second locking mechanism and a hinge wherein the hinge has a slide surface area;
 - wherein the one or more slots extend around the hinge;
 - wherein the slide surface area of the slots is greater than the slide surface area of the hinge; and
 - wherein the first locking mechanism and second locking mechanism are engageable.
14. The container according to claim 15 wherein the hinge is movable relative to the one or more slots.
15. The container according to claim 13 wherein the base further comprises an elastic member, wherein the elastic member extends from a first point in the body to a second point in the body and wherein the elastic member is capable of providing a resistive force to the lid.
16. The container according to claim 13 wherein the slot is juxtaposed at an angle α and wherein the first locking mechanism and the second locking mechanism are juxtaposed at an angle β wherein α is about greater than or equal to β .
17. The container according to claim 13 wherein the first locking mechanism the second locking mechanism are slideably engageable.
18. The container according to claim 13 wherein the container is transitionable from a closed state to an open state upon application of a force on the lid.
19. The container according to claim 13 wherein at least one of the one or more slots further comprises a locking nub.
20. The container according to claim 13 wherein the slot is provided such that the hinge is slideable for a distance that is greater than the length by which the locking mechanisms engage.

* * * * *