

(No Model.)

A. E. BROWN.

HOISTING AND CONVEYING MACHINE.

No. 395,873.

Patented Jan. 8, 1889.

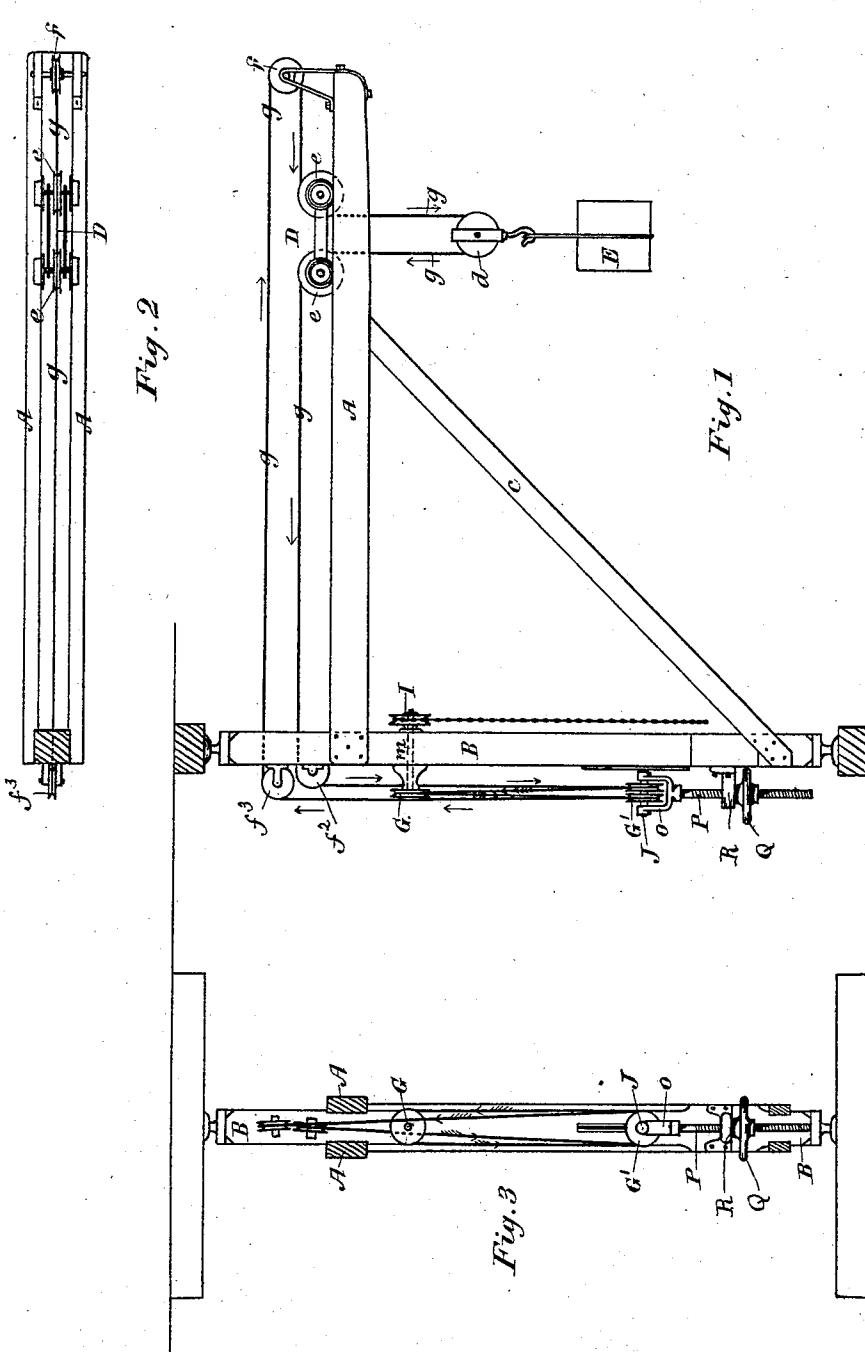

Witnesses

W. J. Graham.

H. Harman

Inventor

Alex. E. Brown.

By J. N. McIntire, Atty.

# UNITED STATES PATENT OFFICE.

ALEXANDER E. BROWN, OF CLEVELAND, OHIO.

## HOISTING AND CONVEYING MACHINE.

SPECIFICATION forming part of Letters Patent No. 395,873, dated January 8, 1889.

Application filed March 15, 1887. Serial No. 231,023. (No model.)

*To all whom it may concern:*

Be it known that I, ALEXANDER E. BROWN, of Cleveland, in the county of Cuyahoga and State of Ohio, have invented an Improved Hoisting and Conveying Machine or Apparatus; and I do hereby declare that the following is a full, clear, and exact description thereof, reference being had to the accompanying drawings, making part of this application.

My invention relates to certain new and useful improvements in that kind of apparatus or contrivance for both lifting and transporting loads in which both the raising and lowering movements of the weight to be manipulated, and also the traversing movement, of the weight are effected through the medium of a single rope or cable.

Previous to my invention machines or contrivances of this known character have been comparatively complicated in their construction and not always convenient and efficient in operation; and my improvements have for their object to simplify the construction and render more convenient of operation and less liable to derangement machines of this species.

To enable those skilled in the art to which my invention relates to understand and practice the same, I will now proceed to more fully describe it, referring by letters to the accompanying drawings, in which I illustrate a machine made according to my improvement.

In the drawings, Figure 1 is a side view or elevation of one of the known forms of crane or hoisting and conveying machine frames, (such as used generally in shops and other works for the handling of heavy stock or other articles,) but embracing my improvement. Fig. 2 is a top or plan view of the same. Fig. 3 is an end or rear view of the apparatus.

In the several figures the same part will be found designated by the same letter of reference.

A represents the horizontal beam or tramway of the crane, B the vertical post or framework about the axis of which the crane revolves, and C a suitable brace for giving the necessary rigidity to the structure. On the rail or rails of the tramway or beam A may be mounted to run in the usual manner any known form of carriage or trolley—such, for

instance, as represented at D—provided, by preference, with an attachable and detachable sheave-block, *d*, from which may be suspended or supported, as illustrated at E, the work, article, or material to be handled.

*f* is a sheave or pulley mounted at or near the outer end of the tramway A in fixed bearings, and over and partially around this sheave is passed the single rope or cable *g*, by which all the movements of the load-carrying contrivance are effected. This rope or cable, as will be seen by reference to Fig. 1, passes from the said pulley *f* (in the directions indicated by the arrows) partially over one of the sheaves *e* of the traveling carriage, thence downwardly and partially around the sheave or wheel of the block *d*; thence upwardly over the other pulley, *e*, of the carriage, thence rearwardly to and partially around the grooved wheel *f*<sup>2</sup>, thence down to and partially around the inner one of the set of wheels at G', thence up to and over the wheel G, thence down again to and partially around the outer one of the two wheels at G', and thence up to and over the wheel *f*<sup>3</sup>, from whence it runs to the point of beginning at the wheel *f*, first mentioned.

In the operation of the contrivance shown and so far described the power for moving the cable *g* (for the purpose of actuating the traversing carriage D, which supports at E the weight) is applied to the shaft *m*, upon which is mounted the sheave or chain-wheel seen at I, while the power used for the purpose of elevating and permitting the descent of the load at E is applied to a shaft, J, which carries the pulleys or wheels G, and which is operated as I will now explain.

In order to raise and lower the load in whatever position the traversing carriage D may be, it is necessary, as just stated, to move the shaft J and the wheels G' bodily from and toward the pulley or sheave G, and for this purpose said shaft J is mounted in a suitable carriage or sliding frame, O, from which depends rigidly a screw-shaft, P, and which is moved up and down by the application of power to a take-up and let-out hand-wheel nut, Q, the hub of which is threaded to shaft P and bears upwardly against a fixed stand, R, through which screw-shaft P slides.

In other words, whenever it may be required to raise or lower the load, the necessary operations are effected by simply turning in one direction or the other the nut-wheel Q on shaft P, which causes the screw-shaft P and the sliding frame or carriage O to move (in one direction or the other) on its ways, thus either shortening or lengthening the distance between the shaft J of the wheels G' and the fixed axis *m* of the grooved wheel or drum, (seen at G,) which of course either takes up or lets out the endless rope *g*, which, as before explained, passes in the directions shown and described around all the wheels or pulleys of the contrivance. By a simple rotation in one direction or the other of the shaft *m* of the grooved wheel shown at G the entire run of the rope or cable *g* is simply set in motion in one direction or the other, (without any change in its length being effected,) and in this manner the traversing carriage D is made to travel back and forth, as may be desired, upon its track on the beam A. Thus by the separate applications of power in the manner just described to either simply rotate the shaft *m* or to slide the carriage O, in which is mounted the shaft J, carrying the sheaves G', the load to be manipulated may be either raised or lowered or may be transported from one locality to another, as the requirements of the work being done may necessitate.

It will be understood, of course, that when necessary for the purpose of an expeditious or economic manipulation of the load both sets of actuating devices may be put in operation simultaneously, so that the load may be either raised or lowered at the same time that it is being moved laterally by a traversing movement of the carriage D.

Having now so fully shown and described my novel construction of machine that those skilled in the art can make and use the same, what I claim therein as new, and desire to secure by Letters Patent, is—

1. In combination with the suitably-supported elevated tramway of a hoisting and conveying machine of the type shown, a carriage adapted to travel on said tramway, the single endless rope or cable *g*, the load-supporting sheave-block *d*, the wheels *f*, *f*<sup>2</sup>, *f*<sup>3</sup>, and G, having fixed axes of motion, and the set of rope-wheels G', having their shaft or axis of motion J mounted in a vertically-movable carriage, O, the whole constructed and operating in the manner and for the purposes set forth.

2. In a hoisting and conveying machine of the type hereinbefore mentioned, the combination, with the elevated tramway, the carriage D, the endless cable *g*, the series of rope-wheels *f*, *f*<sup>2</sup>, *f*<sup>3</sup>, and G, of a drive-wheel, I, mounted fast on the shaft of wheel G, the vertically-adjustable carriage O, in which are mounted the wheels G', and provided with the screw-shaft P, and an actuating nut-wheel, Q, in engagement with said screw-shaft and bearing against a fixed stand, R, the whole arranged and operating substantially as and for the purposes set forth.

In witness whereof I have hereunto set my hand this 31st day of August, 1886.

ALEXANDER E. BROWN.

In presence of—

E. T. SCOVILL,  
CHAS. W. KELLY.