

(19) World Intellectual Property Organization
International Bureau



(43) International Publication Date
28 January 2010 (28.01.2010)

PCT

(10) International Publication Number
WO 2010/010509 A2

- (51) International Patent Classification:
G09F 11/29 (2006.01) *A45F 3/50* (2006.01)
- (21) International Application Number:
PCT/IB2009/053151
- (22) International Filing Date:
21 July 2009 (21.07.2009)
- (25) Filing Language: English
- (26) Publication Language: English
- (30) Priority Data:
2008/06308 21 July 2008 (21.07.2008) ZA
- (71) Applicant and
(72) Inventor: **KOUPIS, Andreas, Nicolaou** [ZA/ZA]; 7
Limosin Street, Helicon Heights, 9301 Bloemfontein
(ZA).
- (72) Inventor; and
(75) Inventor/Applicant (for US only): **LAMBOURN, Paul**
[ZA/ZA]; 14 Tulbagh Street, Alberante, 1449 Alberton
(ZA).
- (74) Agent: **D M KISCH INC**; P O Box 781218, 2146 Sand-
ton (ZA).

- (81) Designated States (unless otherwise indicated, for every kind of national protection available): AE, AG, AL, AM, AO, AT, AU, AZ, BA, BB, BG, BH, BR, BW, BY, BZ, CA, CH, CL, CN, CO, CR, CU, CZ, DE, DK, DM, DO, DZ, EC, EE, EG, ES, FI, GB, GD, GE, GH, GM, GT, HN, HR, HU, ID, IL, IN, IS, JP, KE, KG, KM, KN, KP, KR, KZ, LA, LC, LK, LR, LS, LT, LU, LY, MA, MD, ME, MG, MK, MN, MW, MX, MY, MZ, NA, NG, NI, NO, NZ, OM, PE, PG, PH, PL, PT, RO, RS, RU, SC, SD, SE, SG, SK, SL, SM, ST, SV, SY, TJ, TM, TN, TR, TT, TZ, UA, UG, US, UZ, VC, VN, ZA, ZM, ZW.
- (84) Designated States (unless otherwise indicated, for every kind of regional protection available): ARIPO (BW, GH, GM, KE, LS, MW, MZ, NA, SD, SL, SZ, TZ, UG, ZM, ZW), Eurasian (AM, AZ, BY, KG, KZ, MD, RU, TJ, TM), European (AT, BE, BG, CH, CY, CZ, DE, DK, EE, ES, FI, FR, GB, GR, HR, HU, IE, IS, IT, LT, LU, LV, MC, MK, MT, NL, NO, PL, PT, RO, SE, SI, SK, SM, TR), OAPI (BF, BJ, CF, CG, CI, CM, GA, GN, GQ, GW, ML, MR, NE, SN, TD, TG).

Published:

- without international search report and to be republished upon receipt of that report (Rule 48.2(g))

(54) Title: PLAN OR MAP PROTECTOR AND STORAGE APPARATUS

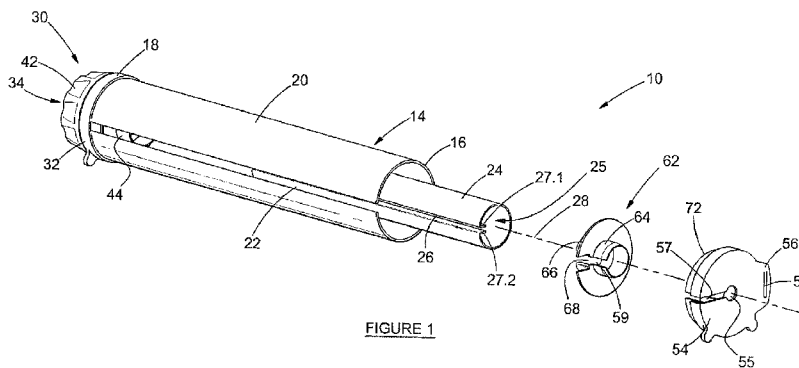

FIGURE 1

(57) Abstract: A portable holder (10) for at least one flexible sheet (12) comprises an inner elongate tube (24) comprising an arresting arrangement (25, 26) for removably arresting a peripheral region (12.1) of the at least one sheet and a coaxial outer elongate tube (14) defining a first elongate slot (22). The inner tube (24) is rotatable relative to the outer tube (14). A first end cap (54) for the outer tube (14) defines a slot (57). The outer tube (14) and inner tube (24) being user manipulatable relative to one another to bring the arresting arrangement (25, 26), first elongate slot (22) and slot (57) of the first end cap into register, so that the at least one sheet may be inserted into the holder to be arrested by the arresting arrangement. A winding mechanism (34) is provided for the inner tube to roll up the at least one sheet on the inner tube.



WO 2010/010509 A2

PLAN OR MAP PROTECTOR AND STORAGE APPARATUS

INTRODUCTION AND BACKGROUND

This invention relates to a holder or apparatus for housing sheets of flexible material, including but not limited to sheets of paper with drawings, plans and maps depicted thereby. The invention also relates to a storage system for such sheets.

It is well known that building plans are often provided on a set comprising a plurality of paper sheets. The sheets are normally A3 size or bigger and may be stacked on one another. The sheets are normally stored in a storeroom or office and, when required on a building site, they are rolled up for ease of transport. At the site, these rolls of sheets are often awkward to handle, to page through and are also subjected to harsh conditions, wherein they may be damaged. Furthermore, safe and convenient storage of the plans are also a problem.

OBJECT OF THE INVENTION

Accordingly, it is an object of the present invention to provide a holder for a plurality of sheets of flexible material and a storage system for such sheets, with which the applicant believes the aforementioned disadvantages may at least be alleviated.

SUMMARY OF THE INVENTION

According to the invention there is provided a portable holder for at least one flexible sheet, the holder comprising:

- an inner elongate member comprising an arresting arrangement for removably arresting a peripheral region of the at least one sheet;
- a coaxial outer elongate tube defining a first elongate slot;
- the inner and outer members being rotatable relative to one another;
- a first end cap for the outer tube mounted at a first end of the outer tube ;
- the first end cap defining a slot; and
- the outer tube and inner member being user manipulatable relative to one another to bring the arresting arrangement, first elongate slot and slot of the first end cap into register, so that the at least one sheet may be removed from the arresting arrangement and the holder, or, inserted into the holder to be arrested by the arresting arrangement.

The inner member may extend between the first end cap and a second end cap at a second end of the outer tube and the inner member may be rotatable relative to the first and second end caps and the outer tube.

The inner member may comprise an inner tube.

The arresting arrangement may comprise an axially extending second elongate slot defined in the inner tube.

The at least one sheet, but typically a plurality of stacked sheets, may be anchored to the inner tube by at least one device connected to the peripheral region of the sheet and which may be axially removable and receivable in a bore of the inner tube, but radially trapped therein with the at least one sheet extending through the second slot.

The at least one device may for example comprise an openable and closeable clamp comprising a first wing and a second wing hinged to a spine and at least one stud on the first wing which, when the first and second wings are hinged towards one another to a closed configuration, is removably arrested by a suitable formation, such as a hole, for example, on the second wing.

A thickness dimension of the clamp between the two wings in the closed configuration may be larger than a width of the second slot, so that the clamp cannot pass through the second slot and is radially trapped in the bore of the inner tube.

The holder may comprise a first radially extending sheet guide wheel towards the first end cap and a second radially extending sheet guide wheel towards the second end cap.

The second guide wheel may be linked to a winding mechanism to be driven thereby.

The winding mechanism may comprise a manually manipulatable wheel, which may be connected by a drive shaft to the second guide wheel. The drive shaft may be an axially extending shaft, for example a hexagonal shaft, which is integral with the second guide wheel and which extends through a hole in the second end cap for free rotation therein and to cooperate with a suitable formation, such as a hexagonal socket, on the manually manipulatable wheel.

In other embodiments, the winding mechanism may comprise automatic drive means such as an electric motor.

The holder may further comprise at least one protective sheet anchored to the inner member. In a preferred embodiment two protective sheets may be provided, so that the at least one sheet may be sandwiched therebetween. The holder may comprise a third and transparent sheet that is not anchored as aforesaid, but which may be

interleaved with the at least one sheet and selectively to be superimposed on a selected one of the at least one sheet, to enable a user to make notes or other marks in manuscript on the third sheet, to supplement the drawing or the like on an underlying sheet

The first, second and third sheets may be made from any durable material and are preferably transparent.

The invention also extends to sub-assemblies of the holder as herein defined or described.

BRIEF DESCRIPTION OF THE ACCOMPANYING DIAGRAMS

The invention will now further be described, by way of example only, with reference to the accompanying diagrams wherein:

- figure 1 is a diagrammatic three dimensional view partially exploded of a holder according to the invention for a stack comprising plurality of sheets of a flexible material;
- figure 2 is a diagrammatic perspective view of the holder and the stack of sheets being slid into the holder from a first end thereof;
- figure 3 is a similar view of the holder with the stack of sheets inserted into the holder and rolled up onto an inner tube in the holder;

- figure 4 is a similar view of the holder with the sheets paid out from the inner tube;
- figure 5 is an exploded three dimensional view of parts of the holder towards a second end thereof;
- figure 6 is a section on line VI in figure 2;
- figure 7 is a section on line VII in figure 3;
- figure 8 is a diagrammatic perspective view of a frame of a storage system; and
- figure 9 is a diagrammatic perspective view of the system.

DESCRIPTION OF A PREFERRED EMBODIMENT OF THE INVENTION

A holder according to the invention for at least one sheet 12 (shown in figure 2) of a flexible material, including but not limited to sheets of paper depicting plans, diagrams, drawings, maps etc is generally designated by the reference numeral 10 in figures 1 to 7 of the diagrams.

Referring to figure 1, the holder 10 comprises an elongate body 14 having a first end 16 and a second end 18. The body 14 comprises a first elongate member in the form of an outer tube 20 extending between the first and second ends and defining a first axially extending slot 22 through which the at least one sheet 12, in use extends. As will be explained hereinafter, a peripheral region of the at

least one sheet 12, in use, is anchored to a second elongate member in the form of a coaxial inner shaft or tube 24 (shown in figures 1, 5 to 7) defining a bore 25. The sheets may be rolled up onto the inner tube, to be user selectively manipulated between a first configuration (shown in figures 3 and 7) wherein it is fully rolled up onto the inner tube and a second configuration (shown in figures 4 and 6) wherein they are at least partially paid out from the inner tube and holder.

As best shown in figures 1, 5, 6 and 7, the inner tube 24 defines an axially extending second slot 26 between opposed inwardly extending lips 27.1 and 27.2, which are formed integrally with the tube 24. The inner tube is rotatable about its own axis 28 by a winding mechanism 30. As best shown in figure 5, in one example embodiment, the winding mechanism is provided at the second end 18 adjacent an end cap 32. The mechanism may be a manual mechanism as shown, comprising a manually manipulatable wheel 34 mounted immediately adjacent the end cap 32. The wheel cooperates with a driven sheet guide wheel 36 mounted in the outer tube 20 on the other side of the end cap 32 as the manually manipulatable wheel 34. The driven wheel comprises a hexagonal stub axle 38 extending axially outwardly through a large enough hole 40 in the end cap 32, so that it is freely rotatable therein. The axle is a tight fit in a formation, such as a

hexagonal socket 41, defined in an inside cheek of the wheel 34. The outside cheek of the wheel 34 comprises a handgrip 42.

On driven wheel 36 and on the other side thereof as the axle 38, there is provided an integral tubular flange 44 defining an interruption between opposed inwardly extending lips 46.1 and 46.2. An outside diameter of the flange is just smaller than an inside diameter of the inner tube 24, so that the flange is a tight fit in the tube with the lips 27.1 and 27.2 abutting against and engaging the lips 46.1 and 46.2.

As best shown in figure 5, the end cap 32 comprises a tubular and axially extending flange 48 having an outside diameter just smaller than an inside diameter of the outer tube 20, so that in use, the flange 48 is a snug fit at the second end 18 of the outer tube. The end cap 32 comprises an integral ear 50 defining a first slot 52.

Referring to figures 1 to 4 and 6, at first end 16 of the holder, there is provided an end cap 54. The end cap 54 comprises a second ear 56 defining a second slot 58. A shoulder band or suitable handle (not shown) may removably be secured to the holder through the slots 52 and 58, to facilitate carrying or handling of the holder 10 by a user.

Referring to figures 1 and 6, the end cap 54 defines a centre hole 55 and a slot 57 extending radially outwardly from the hole 55. On an inside cheek of the cap 54 there is provided an integral axially extending tubular bush. A sheet guide wheel 62 comprises a first integral tubular and axially extending flange 64 (see figure 1) having an outside diameter smaller than an inside diameter of the bush (not shown) on the end cap 54, so that the first flange is a rotatable fit in the bush on the cap. The wheel 62 comprises a second integral axially extending tubular flange 66 having an outside diameter just smaller than an inside diameter of the internal tube 24 and defining an interruption 68 between opposed lips. When the second flange 66 is received in the internal tube 24, the lips engage and abut against the lips 27.1 and 27.2. The wheel 62 and flange 64 define an axially extending slot 59 (shown in figure 1), which is axially in line with the interruption 68 and second slot 26 in the inner tube 24.

The end cap 54 comprises a tubular coaxial and axially extending flange 72 to secure the end cap to the outer tube 20.

Referring now to figure 2, the at least one sheet 12, but typically a stack of sheets are secured in a peripheral region 12.1 thereof to at least one clamp element 74.1 to 74.n. The clamp elements are similar in configuration and therefore clamp element 74.1 only will be

described in more detail with reference to figure 7. Clamp element 74.1 comprises first and second wings 76 and 78 hinged to a spine 80. The clamp element may be integrally formed from a suitable plastics material and the hinge may for example be provided by suitable reductions in the material. At least one integral stud 82 may stand proud from one wing and is removably receivable in a formation such as a hole 84, defined in the other wing. The thickness d of the clamp elements is larger than the width of the second slot 26 in the inner tube, but the width w and thickness d are smaller than the diameter of hole 55 in end cap 54, so that the clamp could pass through hole 55. In use, the clamps are mounted at the one end of the at least one sheet with the studs extending through holes 85 (shown in figure 2) punched into the at least one sheet 12. The axially aligned clamp members therefore form a spine in region 12.1 for the stack of papers. As shown in figure 2, at the opposed end 12.2 of the at least one sheet 12, there is provided an elongate protective and removable handling strip 86.

Referring to figure 2 and 6, to insert the at least one sheet into an empty holder, the winding wheel 34 is manipulated to bring slot 26 in inner tube 24 and slot 22 in outer tube 20 in register. The slot 57 in the first end cap is then also aligned with the aforementioned registering slots. The user then slides the spine region 12.1 of the at

least one sheet 12 comprising clamp elements 74.1 to 74.n axially through hole 55 and simultaneously the adjacent region of the at least one sheet through aligned slots 57, 22 and 26, until they reach the position shown in figure 4. Hence, the at least one sheet is inserted and/or removed from the holder without the necessity of disassembling or partially disassembling the holder. Because of the aforementioned relative dimensions, the clamp elements 74.1 to 74.n are radially trapped in the bore 25 of the inner tube as shown in figures 6 and 7.

The holder 10 may comprise at least one, preferably two transparent protective and liquid impermeable sheets (not shown), between which a stack of paper sheets 12 with drawings, plans, maps etc may be sandwiched. The strip 86 may be permanently secured to one of the protective sheets and may provide a fluid tight closure for the slot 22. The holder may further comprise a separate intermediate transparent sheet, which may not be anchored as aforesaid, but which may be removed from the stack by the user when paid out and then superimposed on any selected paper sheet in the stack, to enable the user to make notes or other additions in manuscript in an erasable or other ink on the intermediate sheet, to supplement the underlying drawing, for example.

It will be appreciated that the clamp elements 74.1 to 74.n, which are openable and closable to receive replacement or additional sheets and which, due to their configuration, are radially trapped in the inner tube, provide a convenient and easy to use mechanism of collating and storing a stack of sheets for storage in the holder. The holder with manually manipulatable winding wheel 34 provides a convenient mechanism for rolling up the stack or paying the stack out for use by a user. Other winding mechanisms such as a crank and/or an electric motor may also be used. The motor may be driven by battery and/or solar power. The motor may be controlled by a controller, which may be configured to cause the motor to pay out and/or pay in only predetermined lengths of the sheet. Other means to ensure that the sheets, when not anchored on the inner shaft as aforesaid, cannot be paid out entirely from the outer tube may comprise a brake, a length of string connected between the at least one sheet and the inner shaft or outer tube, a spring-loaded mechanism etc. A spring loaded mechanism may in any event be connected to the inner shaft to facilitate paying in the at least one sheet.

The optional protective transparent sheets protect the stack in harsh environments. The holder protects its contents and is believed to be convenient to carry and transport, as well as to store away.

A suitable bearing arrangement (not shown) may be provided between the inner tube and the end caps on the outer tube.

An array of at least two juxtaposed and interconnected holders may also be provided. In one embodiment of the array, two holders as herein described may be connected to one another back-to-back, so that the respective openings 22 face away from one another.

A more permanent storage system for stacks of at least one sheet 12.1 and which system may be used in an office or a store-room, is shown in figures 8 and 9. The system comprises a wall mountable frame 100 comprising a rectangular frame 102, strut members 104 and a plurality of removable rail providing suspension members 106. Each member 106 comprises an elongate body 108 defining a plurality of axially extending rails or channels 110.1 to 110.5. The channels may be inverted U-shaped and base members 111 at the free ends of the inverted U define a slot 113 between them having a width smaller than the thickness d of the clamp elements 74.1 to 74.n, so that the spine regions may be trapped in the channels in a manner similarly to within the bore 25 of the inner tube 24, when the housed in the holder 10, as hereinbefore described. At opposed ends of the body there are provided inverted U-shaped engagement members 112 for removably engaging opposed end members of frame 102. The aforementioned

channels are configured slidingly and removably to receive the aforementioned spine region 12.1 of a stack of at least one sheet 12.

Hence, the stack may be stored in an office or store-room on frame 102. When drawings in the stack are required at a building site remote from the storage site, the stack may be removed from the frame, inserted into an empty holder 10 as hereinbefore described, transported to the remote site, used there as hereinbefore described, transported back to the storage site and reinserted in the channel of the suspension member, by axially sliding the spine region into the channel.

The invention also extends to a system comprising the storage system as herein defined and or described and at least one holder as herein defined and/or described.

Claims

1. A portable holder for at least one flexible sheet, the holder comprising:
 - an inner elongate member comprising an arresting arrangement for removably arresting a peripheral region of the at least one sheet;
 - a coaxial outer elongate tube defining a first elongate slot;
 - the inner member and outer member being rotatable relative to one another;
 - a first end cap for the outer tube mounted at a first end of the outer tube ;
 - the first end cap defining a slot; and
 - the outer tube and inner member being user manipulatable relative to one another to bring the arresting arrangement, first elongate slot and slot of the first end cap into register, so that the at least one sheet may be removed from the arresting arrangement and the holder, or, inserted into the holder to be arrested by the arresting arrangement.

2. A holder as claimed in claim 1 wherein the inner member extends between the first end cap and a second end cap at a second end of the outer tube.

3. A holder as claimed in claim 1 or claim 2 wherein the inner member comprises an inner tube.
4. A holder as claimed in claim 3 wherein the arresting arrangement comprises a bore of the inner tube and an axially extending second elongate slot region defined in the inner tube.
5. A holder as claimed in claim 4 wherein the at least one sheet is arrested in the bore of the inner tube by at least one device connected to the peripheral region of the sheet and which device is axially removable and receivable in the bore of the inner tube, but radially trapped therein with the at least one sheet extending through the second slot.
6. A holder as claimed in claim 5 wherein the at least one device comprises an openable and closeable clamp comprising a first wing and a second wing hinged to a spine and at least one stud on the first wing which, when the first and second wings are hinged towards one another to a closed configuration, is removably arrested by a suitable formation on the second wing.
7. A holder as claimed in claim 6 wherein a thickness dimension of the clamp between the two wings in the closed configuration is

larger than a width of the second slot, so that the clamp cannot pass through the second slot and is radially trapped in the bore of the inner tube.

8. A holder as claimed in any one of claims 2 to 7 wherein the holder comprises a first radially extending sheet guide wheel towards the first end cap and a second radially extending sheet guide wheel towards the second end cap.
9. A holder as claimed in claim 8 wherein the second guide wheel is linked to a winding mechanism to be driven thereby.
10. A holder as claimed in claim 9 wherein the winding mechanism comprises a manually manipulatable wheel, which is connected by an axially extending drive shaft to the second guide wheel, the drive shaft extending through a hole in the second end cap for free rotation therein to cooperate with a suitable formation on the manually manipulatable wheel.
11. A holder as claimed in any one of claims 1 to 10 comprising at least one protective sheet anchored to the inner member.

12. A holder as claimed in claim 11 comprising first and second protective sheets with the at least one sheet sandwiched therebetween.
13. A holder as claimed in claim 12 comprising a third and transparent loose sheet.
14. A holder as claimed in claim 13 wherein the first, second and third sheets are made from a durable transparent material.
15. A system for storing and transporting at least one flexible sheet, the system comprising:
 - a central and stationary storage facility;
 - the facility comprising at least one suspender for suspending the at least one sheet by a peripheral region of the at least one sheet;
 - the sheet being removably receivable by the suspender; and
 - at least one portable holder as claimed in any one of claims 1 to 14.

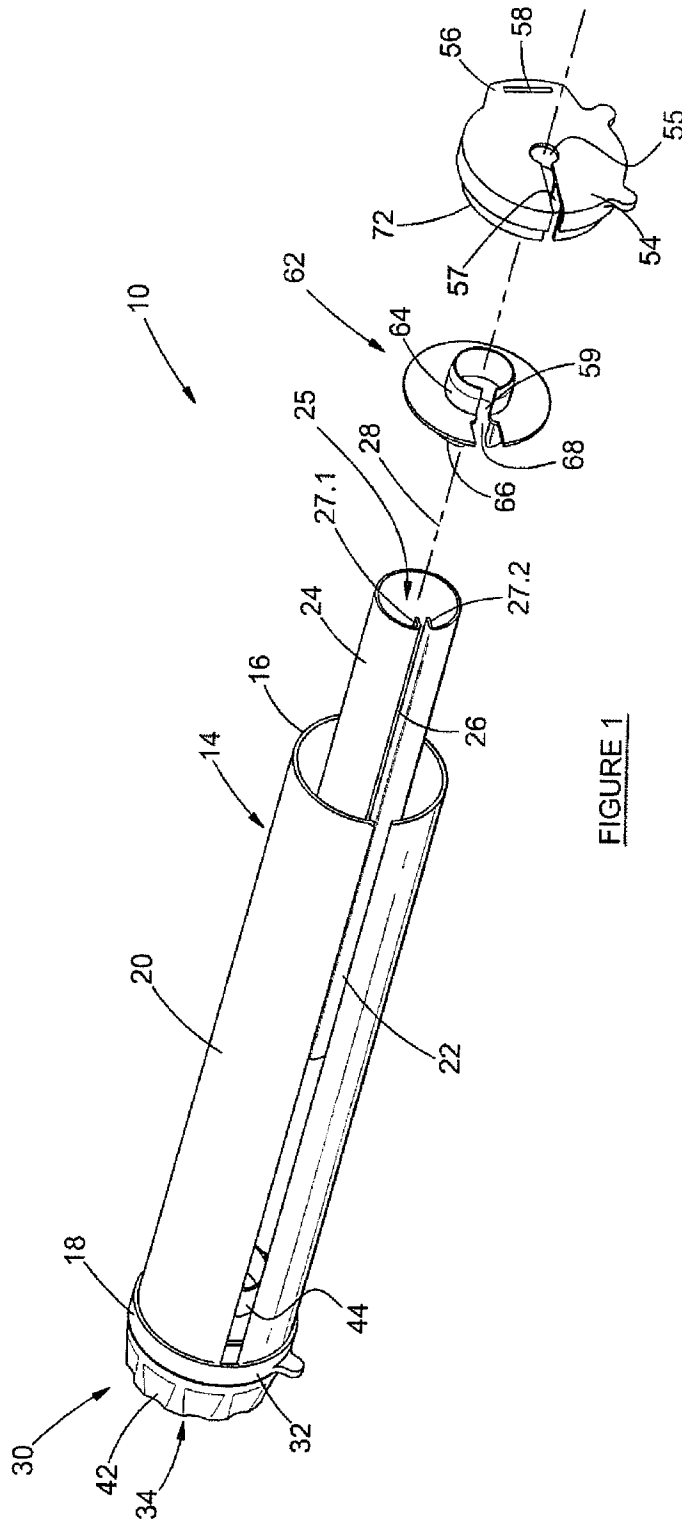

FIGURE 1

2/7

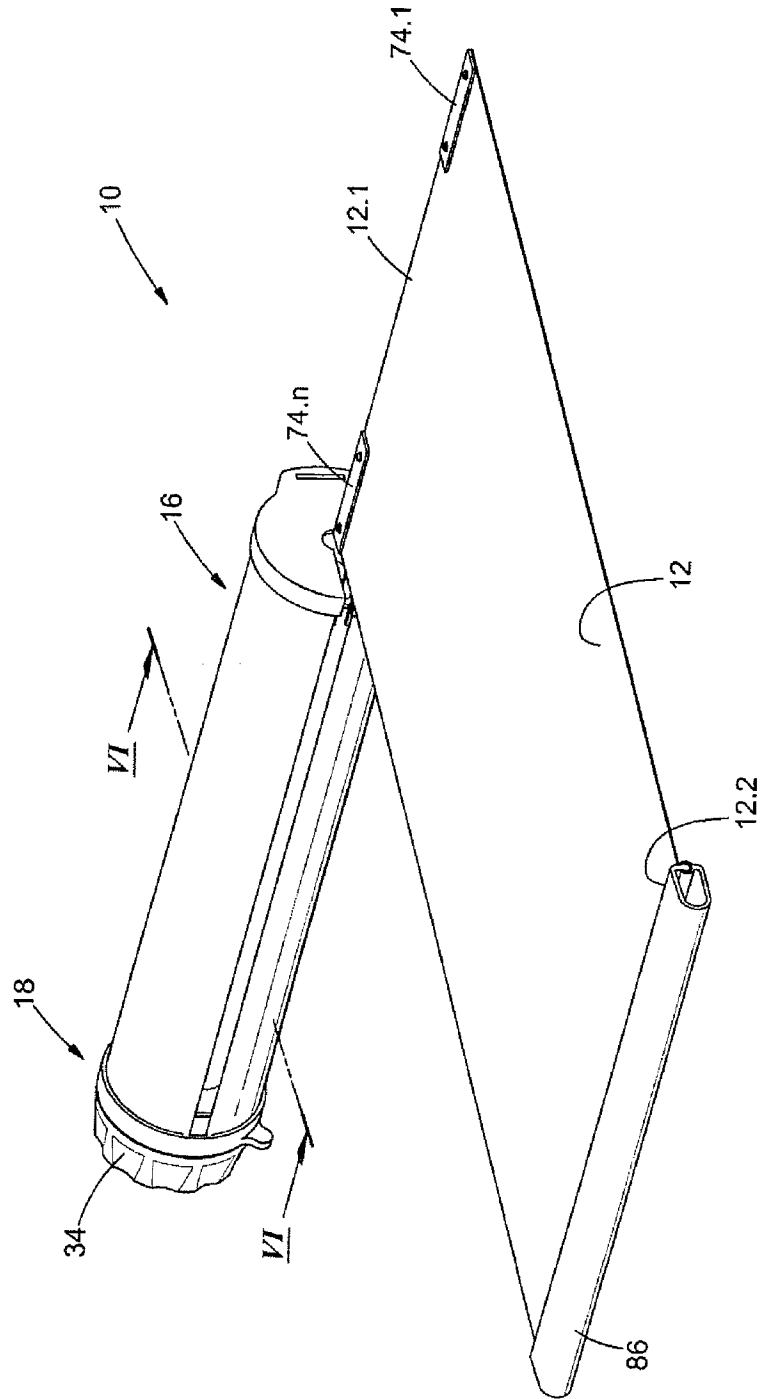

FIGURE 2

3/7

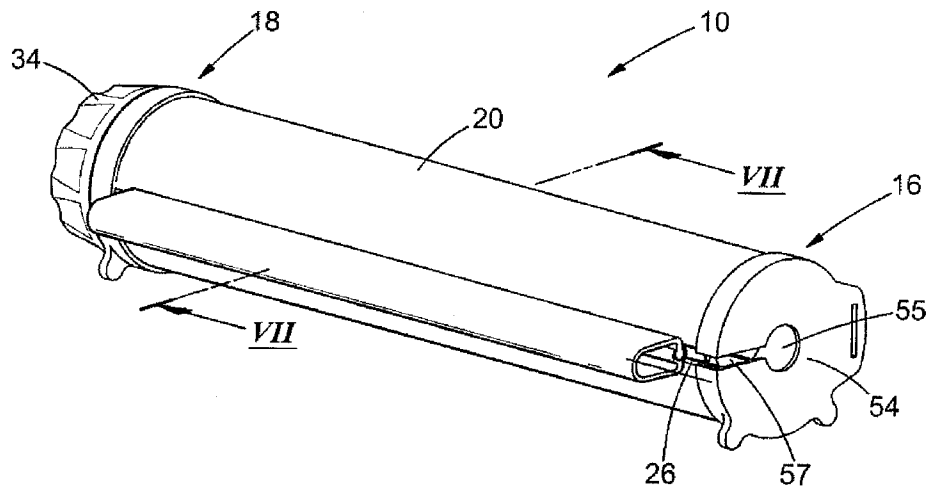

FIGURE 3

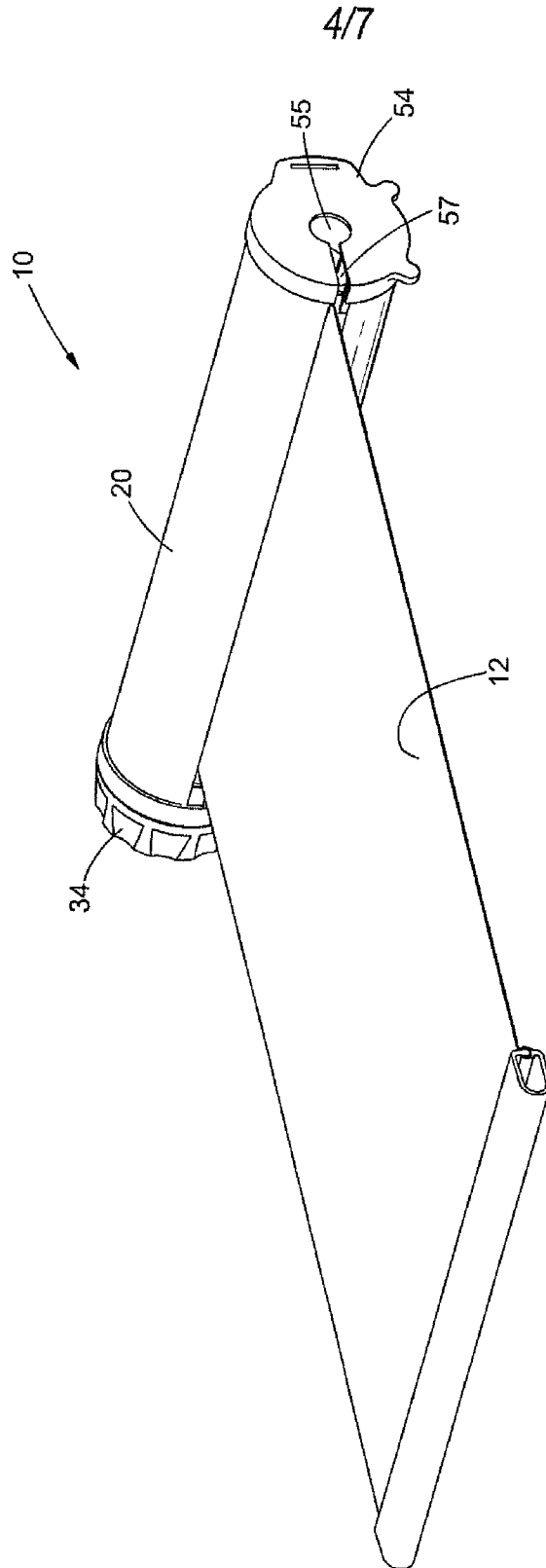

FIGURE 4

5/7

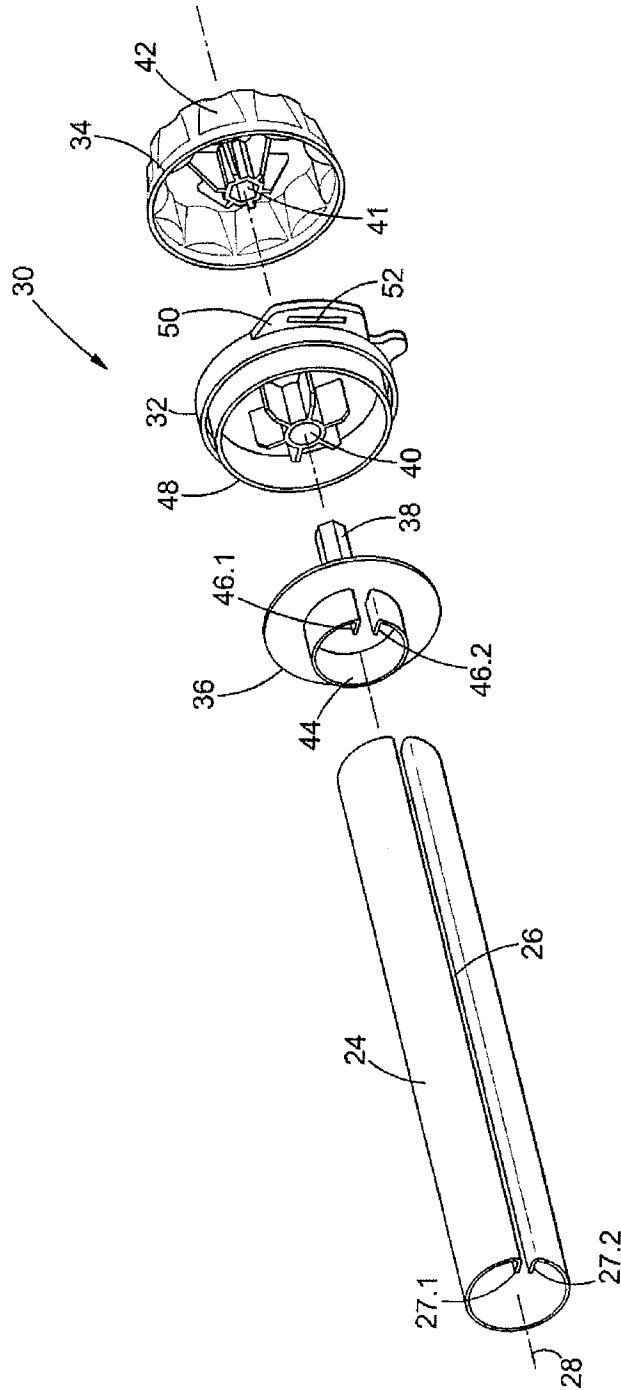

FIGURE 5

6/7

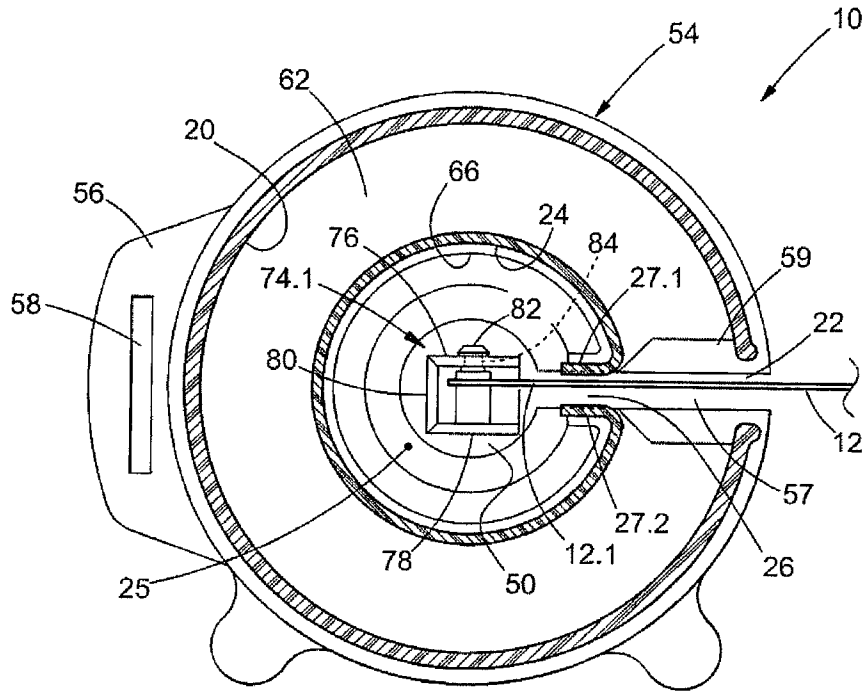

FIGURE 6

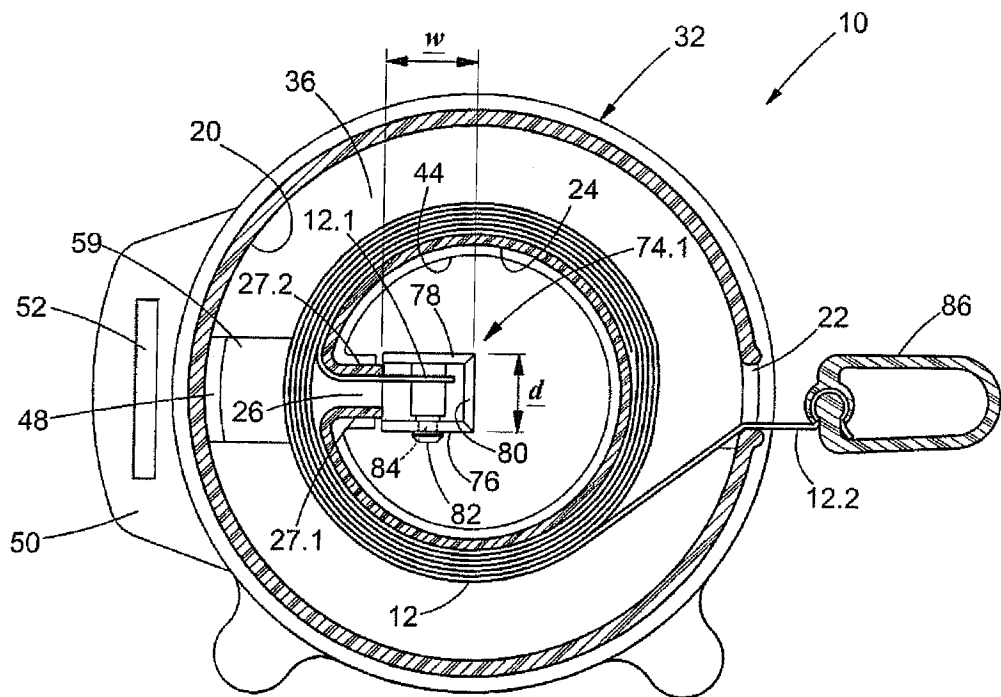

FIGURE 7

7/7

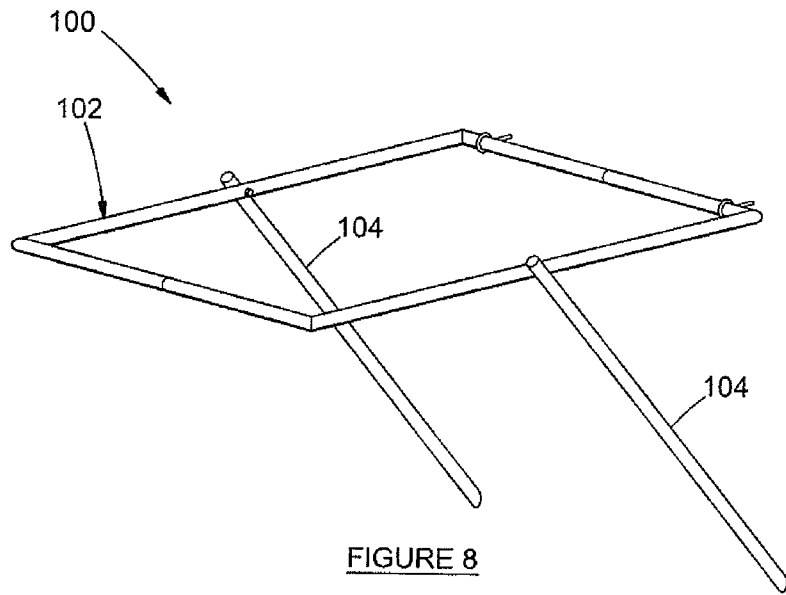

FIGURE 8

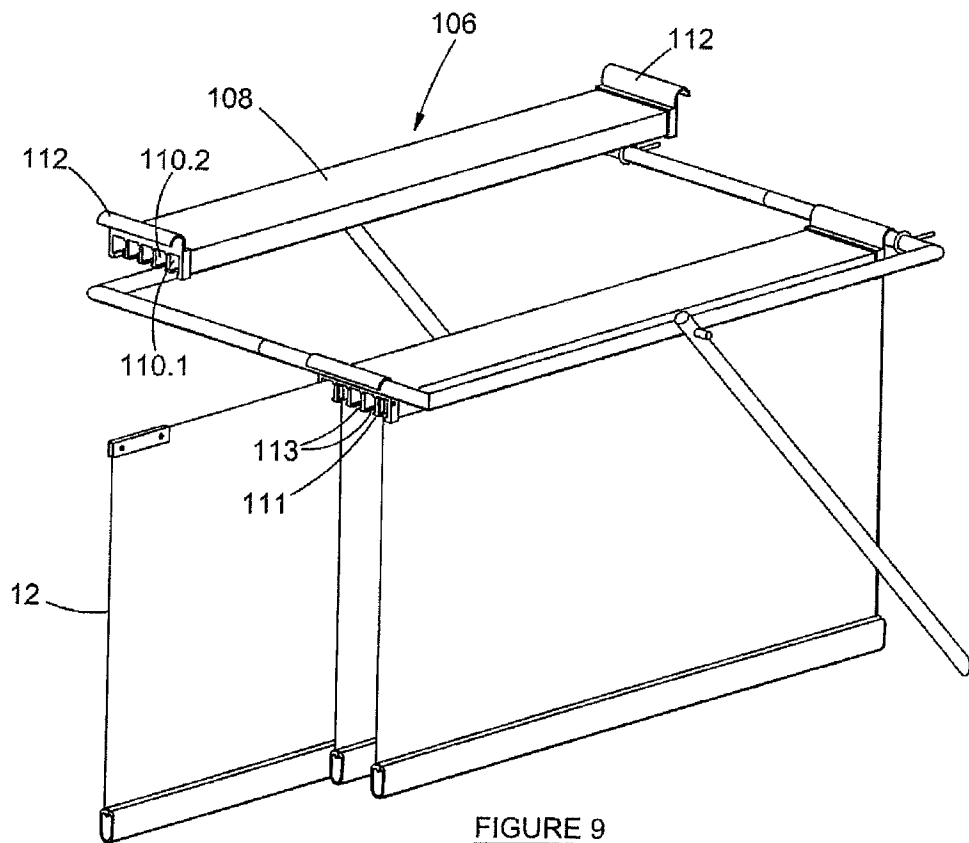

FIGURE 9