



US00RE47322E

(19) **United States**
(12) **Reissued Patent**
Danielson et al.

(10) **Patent Number:** **US RE47,322 E**
(45) **Date of Reissued Patent:** **Mar. 26, 2019**

(54) **RAPID EVACUATION AND CHARGING SYSTEM, AND APPARATUS AND METHODS RELATING THERETO**

Y10T 137/0447; Y10T 137/6109; Y10T 137/7613; Y10T 137/6011; Y10T 29/53596; Y10T 29/53552
USPC 137/315.41, 15.18, 315.11, 454.5; 29/213.1, 221.6; 62/292, 293, 77
See application file for complete search history.

(71) Applicant: **Fastest Inc.**, Roseville, MN (US)

(72) Inventors: **Robert B. Danielson**, Ham Lake, MN (US); **Stanlee Meisinger**, Roseville, MN (US)

(56) **References Cited**

U.S. PATENT DOCUMENTS

(73) Assignee: **FasTest, Inc.**, Roseville, MN (US)

2,006,712 A 7/1935 Forbes et al.
2,170,478 A 8/1939 Long et al.
2,524,951 A 10/1950 Ashton
2,594,641 A 4/1952 Griffith et al.

(21) Appl. No.: **15/622,512**

(Continued)

(22) Filed: **Jun. 14, 2017**

Related U.S. Patent Documents

FOREIGN PATENT DOCUMENTS

Reissue of:

(64) Patent No.: **6,901,947**
Issued: **Jun. 7, 2005**
Appl. No.: **10/005,965**
Filed: **Nov. 8, 2001**

FR 1512786 1/1968
FR 1512786 2/1968
GB 1123159 8/1968

U.S. Applications:

(60) Provisional application No. 60/246,796, filed on Nov. 8, 2000.

OTHER PUBLICATIONS

“From leak detection through evacuation and charging . . . How to make your total job easier, faster and more effective,” Ritchie Engineering Company, Inc., Edition 45a, 4 pgs (copyright 1995).
(Continued)

(51) **Int. Cl.**

F16L 37/23 (2006.01)
F16L 55/18 (2006.01)
F16L 37/00 (2006.01)

Primary Examiner — William C Doerrler
(74) *Attorney, Agent, or Firm* — Hamre, Schumann, Mueller & Larson, P.C.

(52) **U.S. Cl.**

CPC **F16L 37/23** (2013.01); **F16L 55/18** (2013.01); **Y10T 29/53552** (2015.01); **Y10T 29/53596** (2015.01); **Y10T 137/0447** (2015.04); **Y10T 137/0491** (2015.04); **Y10T 137/6011** (2015.04); **Y10T 137/6109** (2015.04); **Y10T 137/7613** (2015.04)

(57) **ABSTRACT**

A system for performing rapid charging and evacuation of systems that contain a fluid, such as cooling systems on refrigeration products. In addition, the invention relates to methods of accomplishing rapid charging and evacuation, as well as to tools that form part of the system and that are used to accomplish the methods.

(58) **Field of Classification Search**

CPC F16L 37/23; F16L 55/18; Y10T 137/0491;

28 Claims, 19 Drawing Sheets

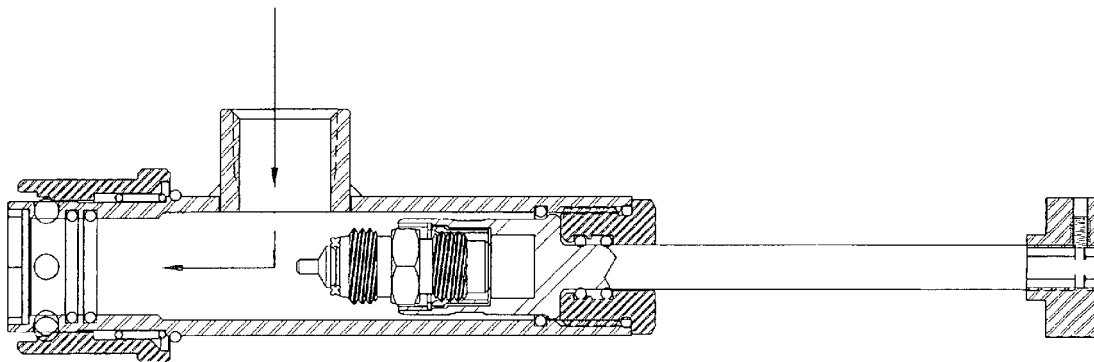

US RE47,322 E

Page 2

(56)

References Cited

U.S. PATENT DOCUMENTS

2,645,451 A 7/1953 Gladden
2,928,417 A 3/1960 Buckner et al.
3,083,723 A 4/1963 Duchin et al.
3,299,648 A * 1/1967 White B60H 1/00585
62/149
3,419,040 A 12/1968 Thibodeaux
3,756,273 A 9/1973 Hengesbach
3,800,824 A 4/1974 Medina
3,916,947 A 11/1975 Holmes et al.
3,935,713 A * 2/1976 Olson B25B 27/24
29/221.6
3,995,658 A 12/1976 Hager
4,026,320 A 5/1977 Grahl
4,182,370 A * 1/1980 Karcher 137/614.04
4,506,695 A 3/1985 Kuypers
4,644,973 A 2/1987 Itoh et al.
4,979,721 A 12/1990 Gilbert
5,067,521 A 11/1991 Jenks et al.

5,139,049 A 8/1992 Jensen et al.
5,349,998 A * 9/1994 Gonfiantini F25B 45/00
137/522
RE34,781 E * 11/1994 Spalink et al. 137/614.05
5,396,774 A 3/1995 Hubbell, Jr.
5,803,108 A * 9/1998 Schuessler et al. 29/221.5
6,039,303 A 3/2000 Danielson et al.
6,050,295 A 4/2000 Meisinger et al.
6,073,974 A 6/2000 Meisinger et al.
6,152,165 A * 11/2000 Fukuda B25B 13/48
137/223
6,354,100 B1 * 3/2002 Spanos F25B 45/00
137/454.2

OTHER PUBLICATIONS

"Robinair, World Choice Tools and Equipment For The HVAC/R Service Professional," Robinair Division, SPX Corporation, 3 pgs (copyright 1996).

* cited by examiner

FIG. 1
Prior Art

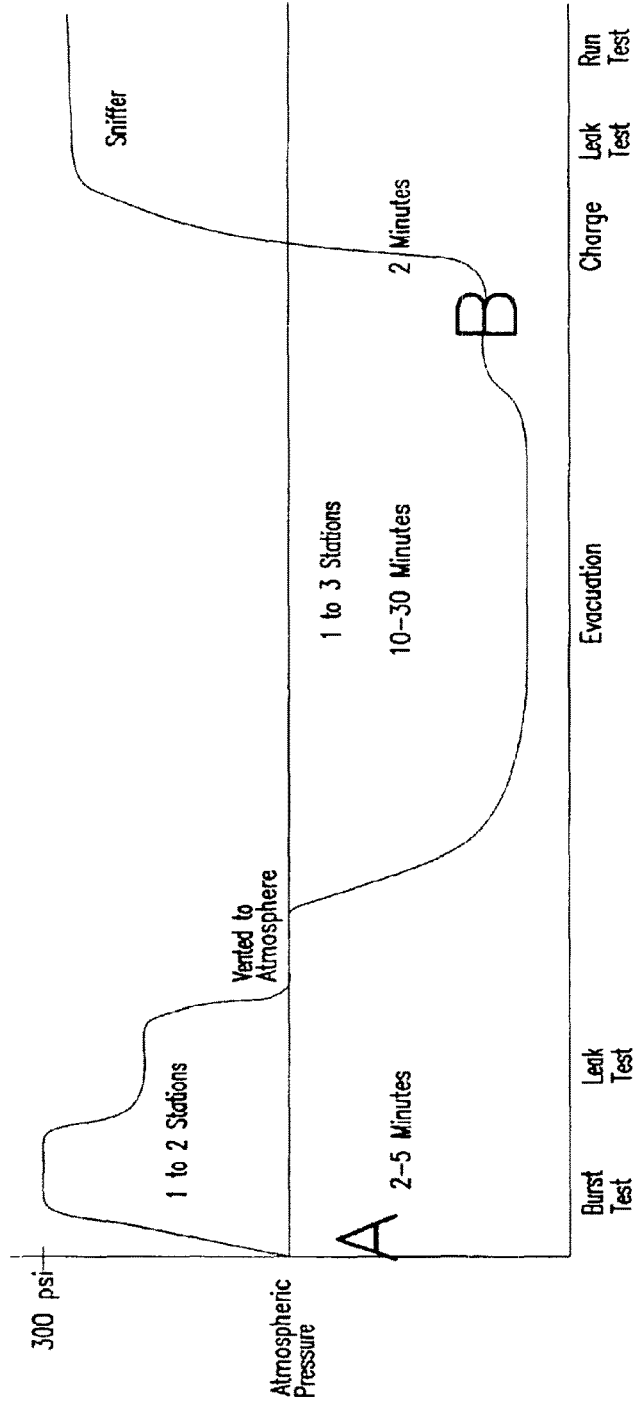
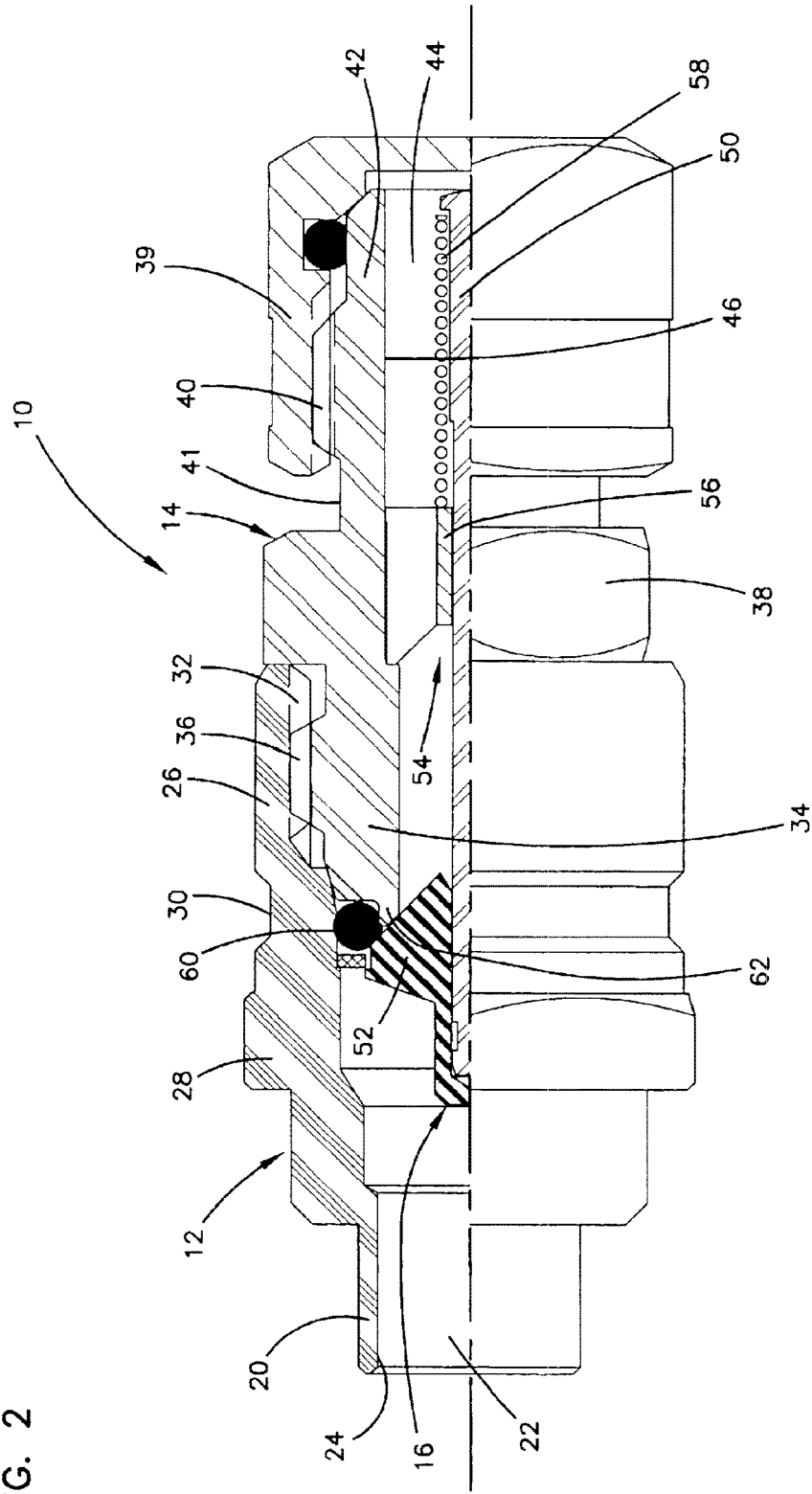

FIG. 2



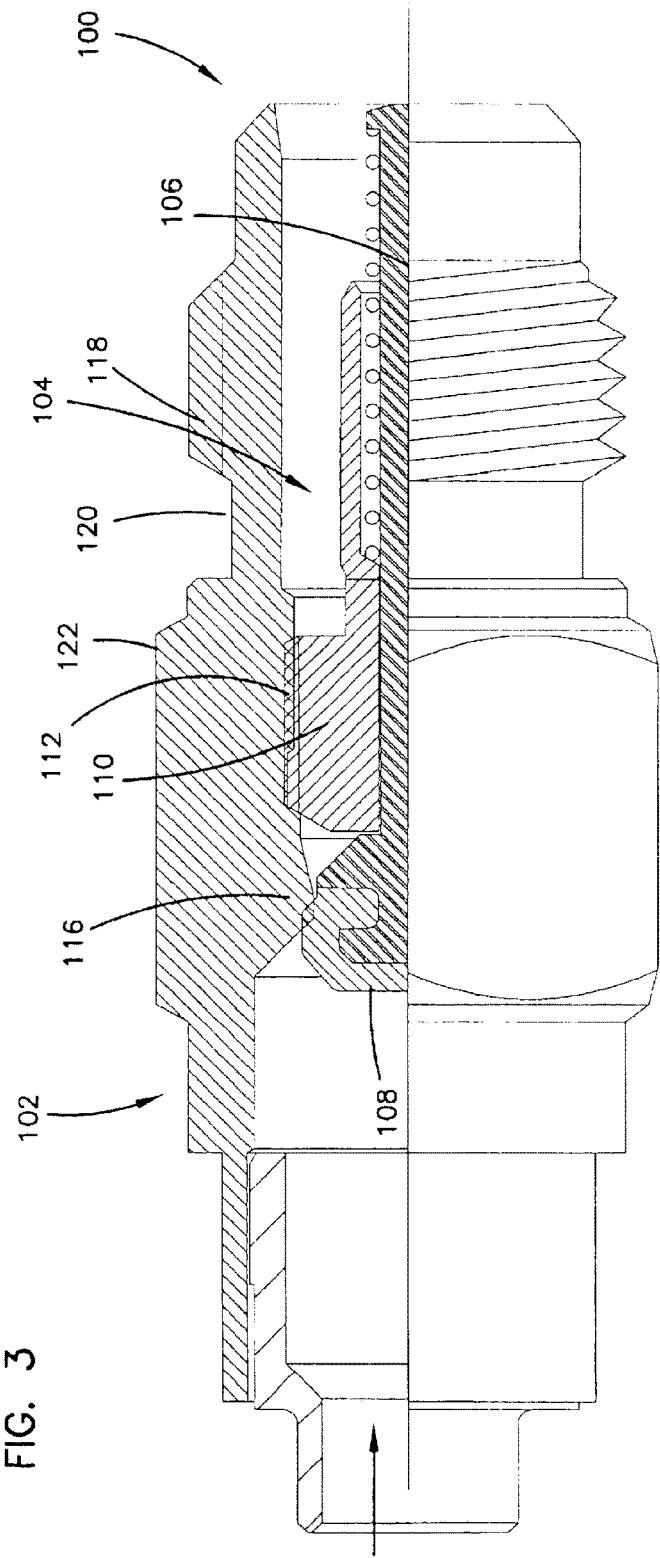
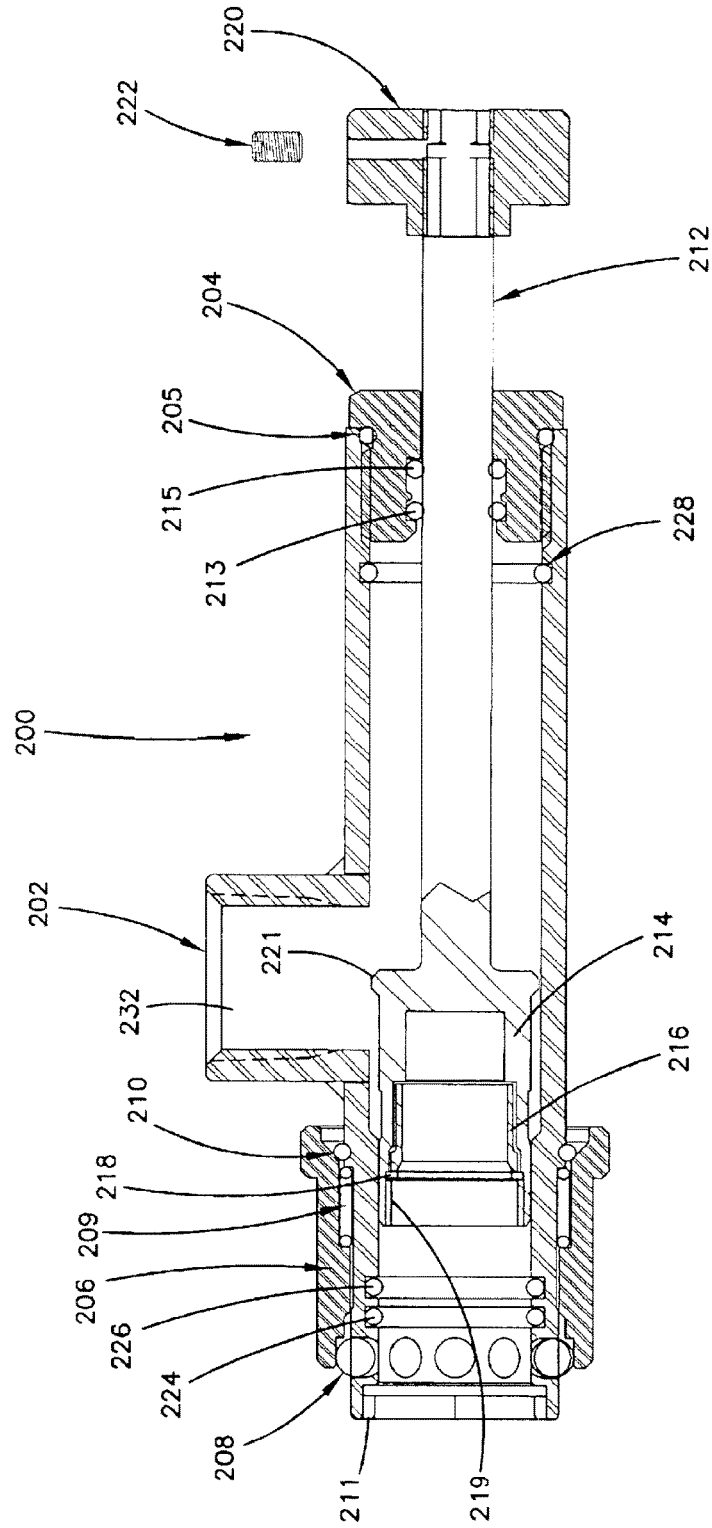

FIG. 3

FIG. 4



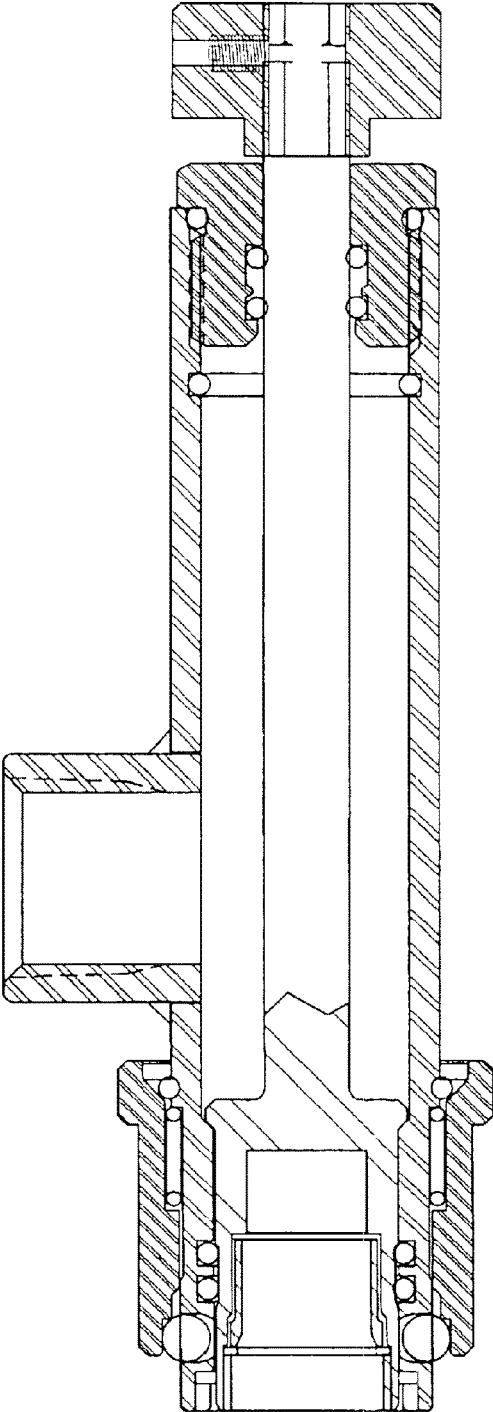

FIG. 5A

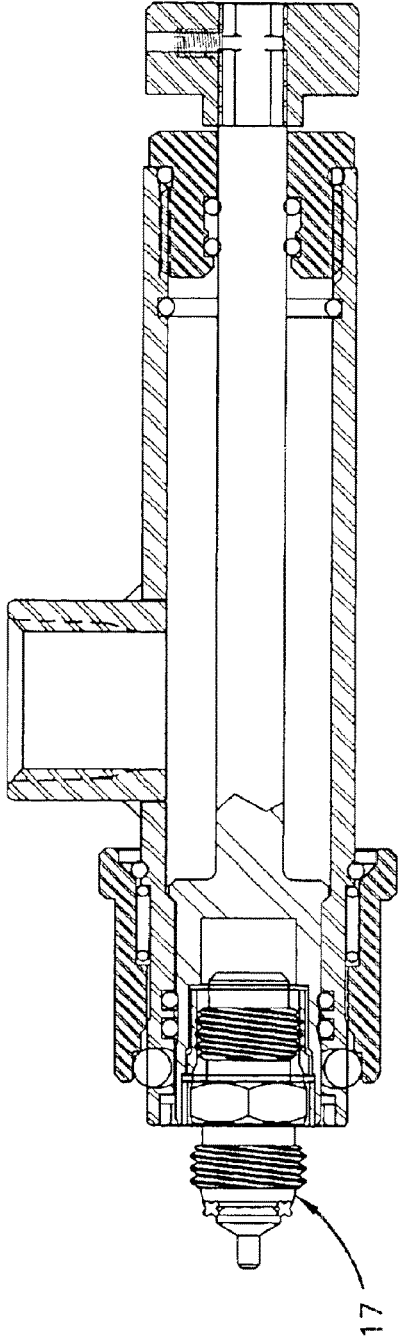

FIG. 5B

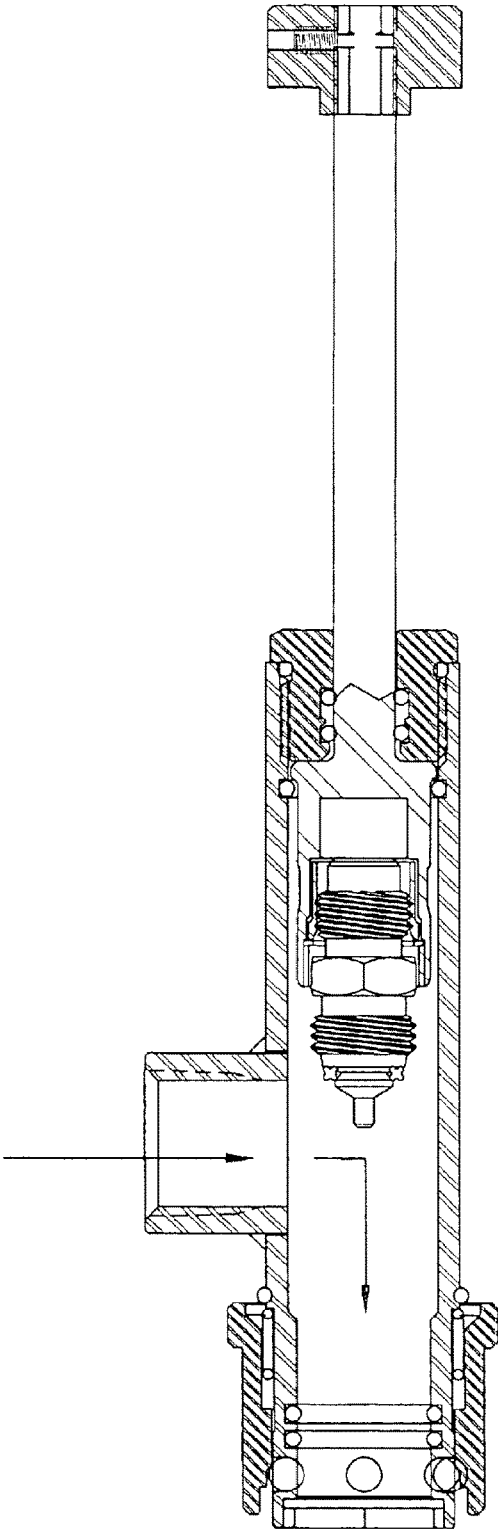

FIG. 5C

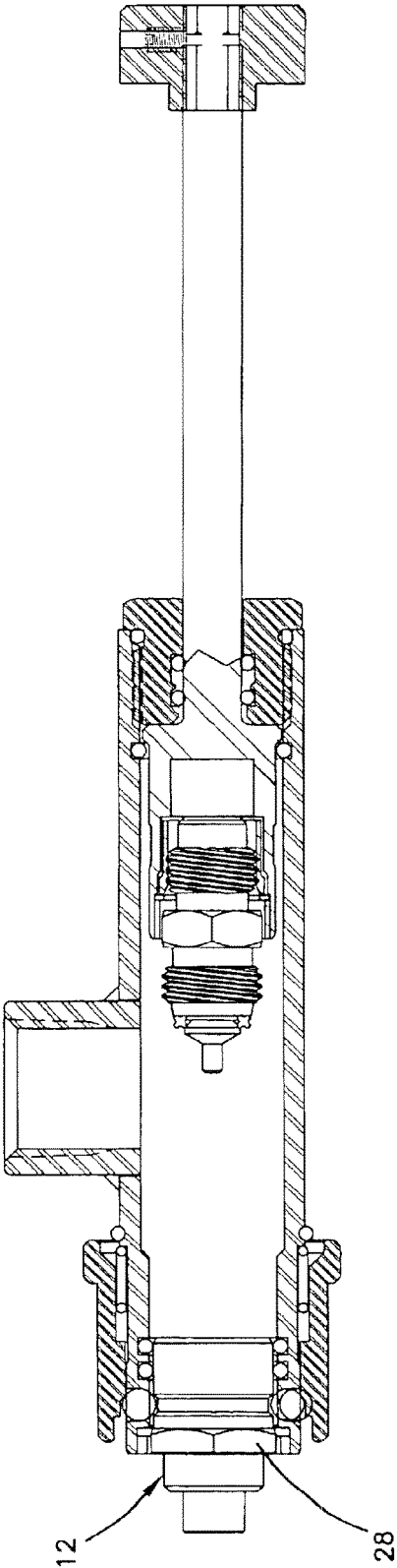

FIG. 5D

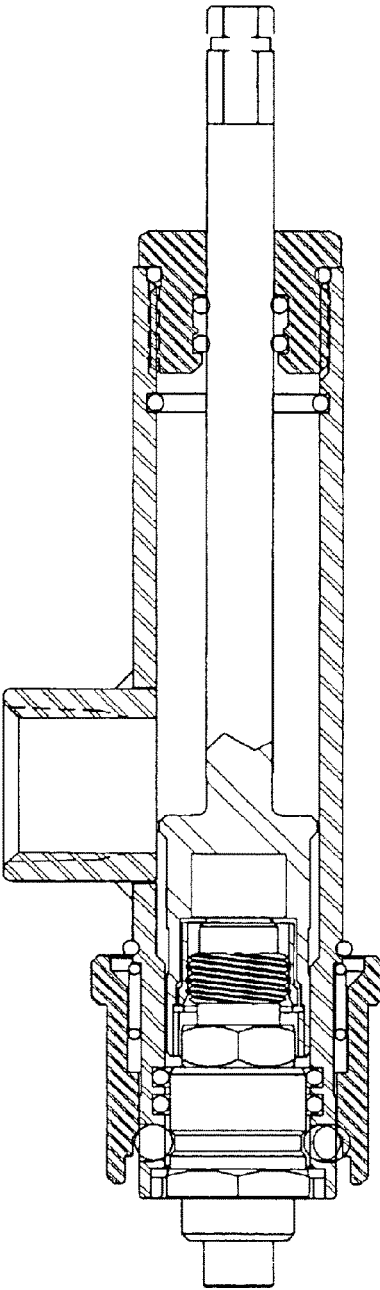
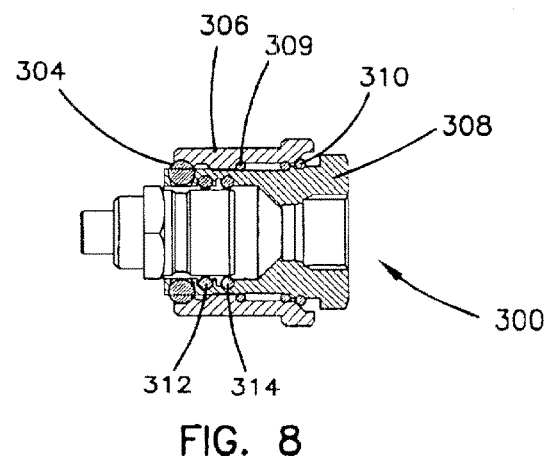
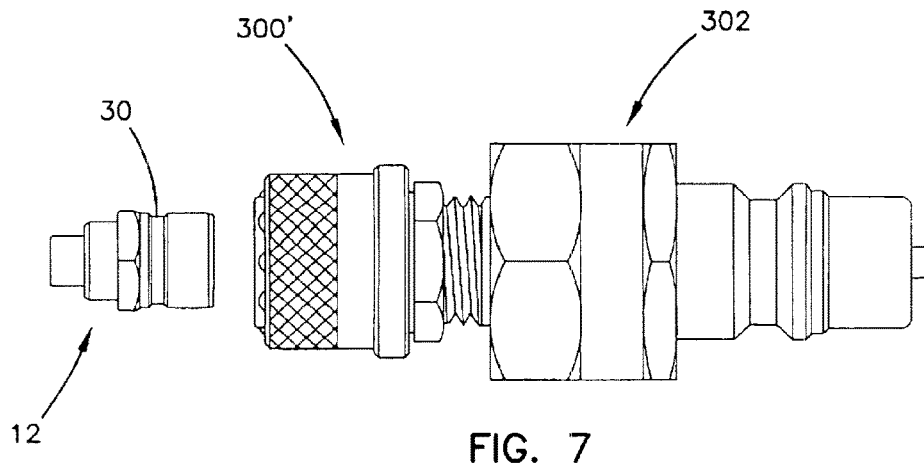
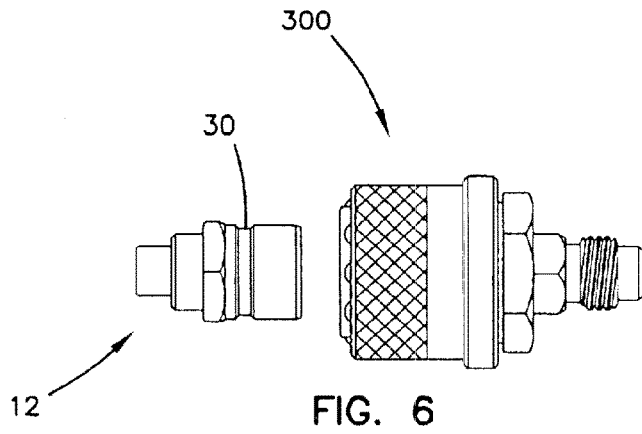

FIG. 5E



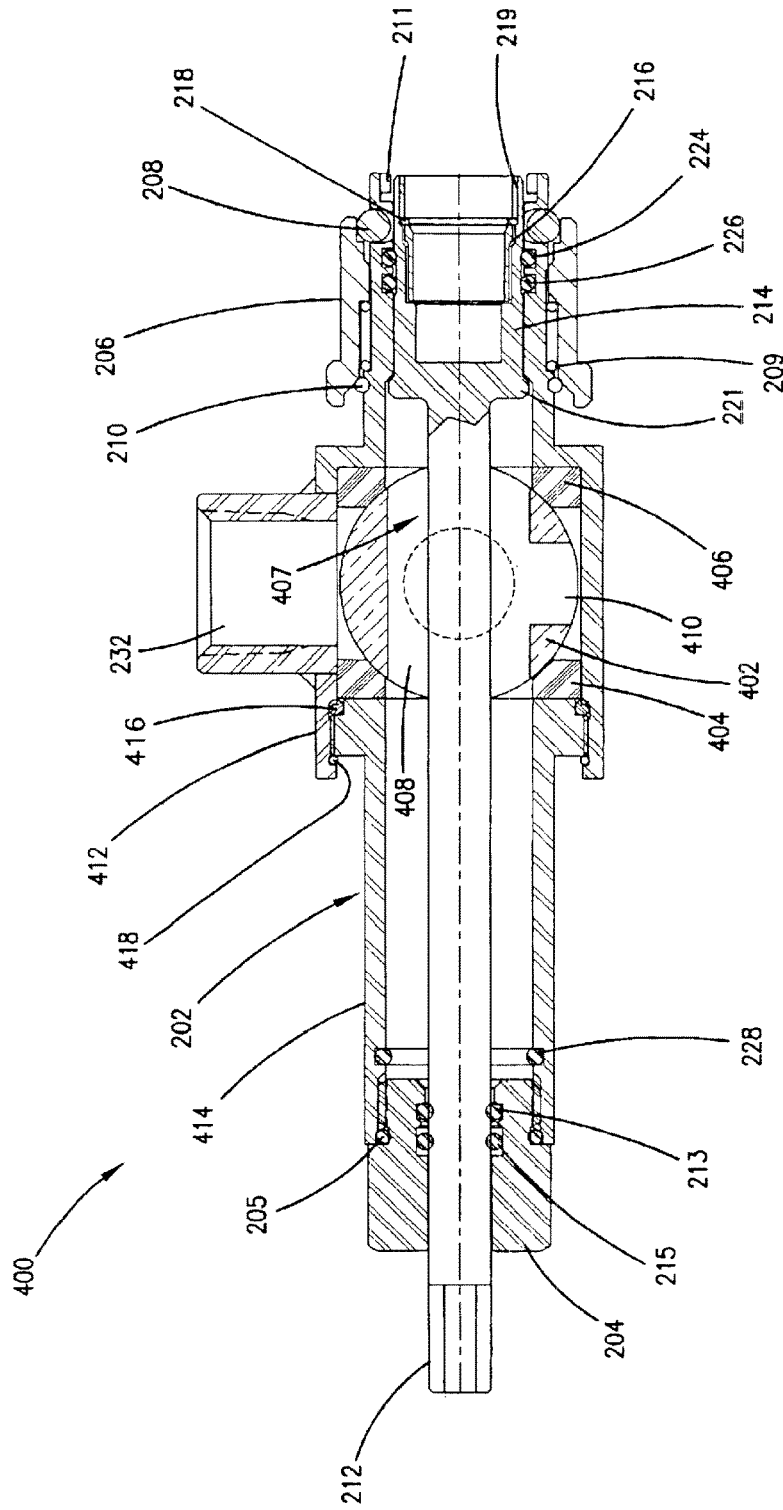

FIG. 9

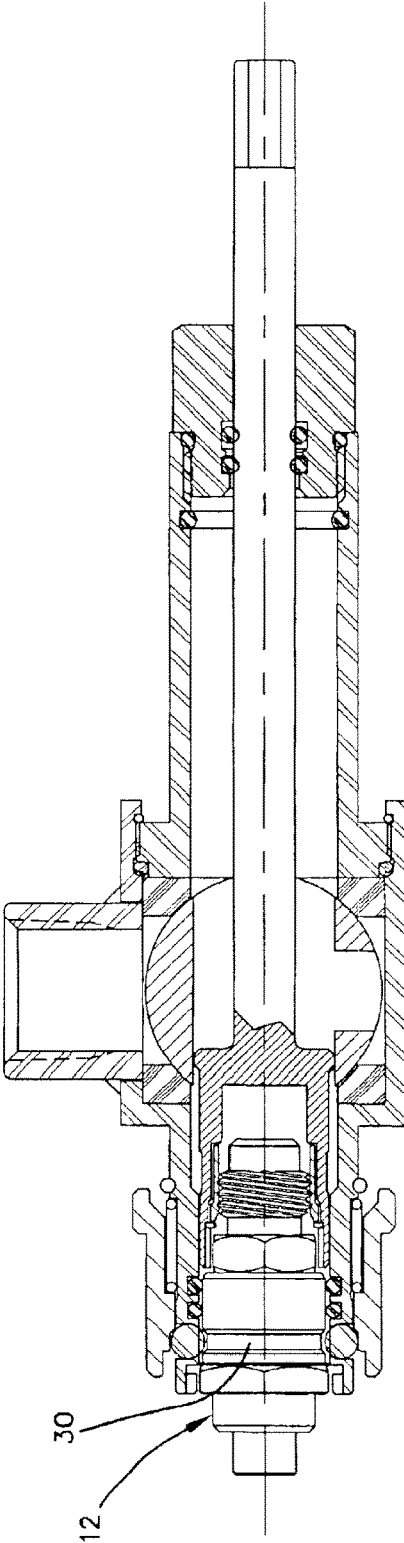

FIG. 10A

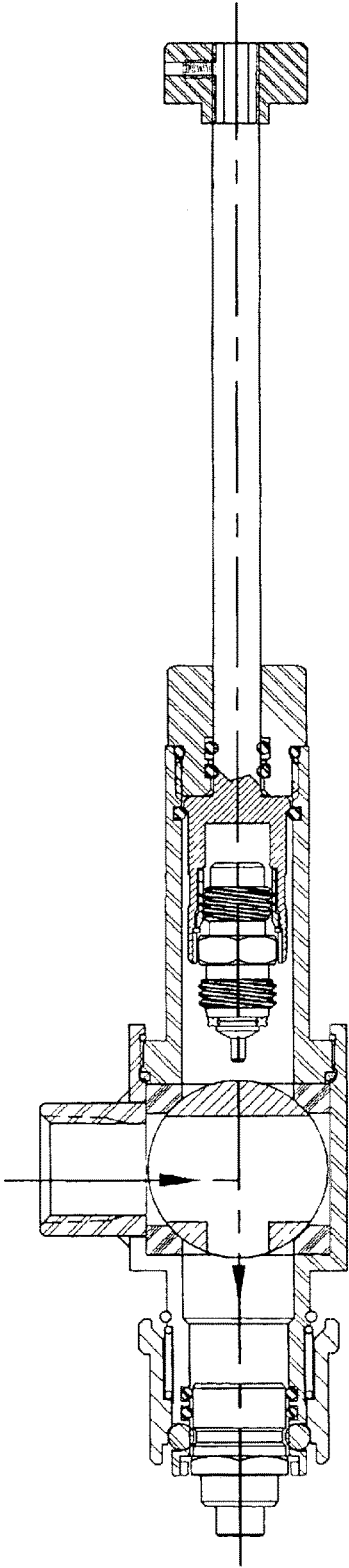

FIG. 10B

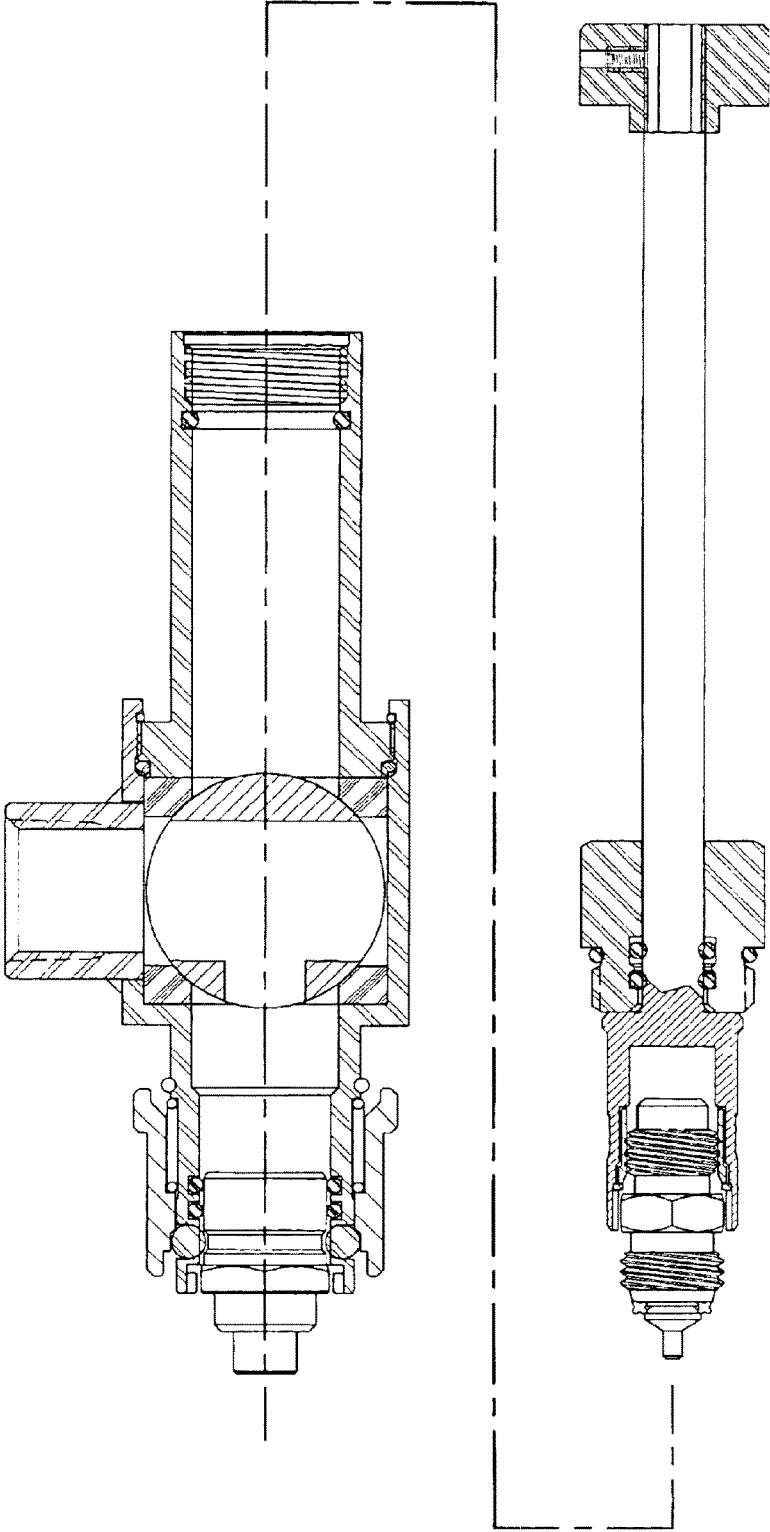
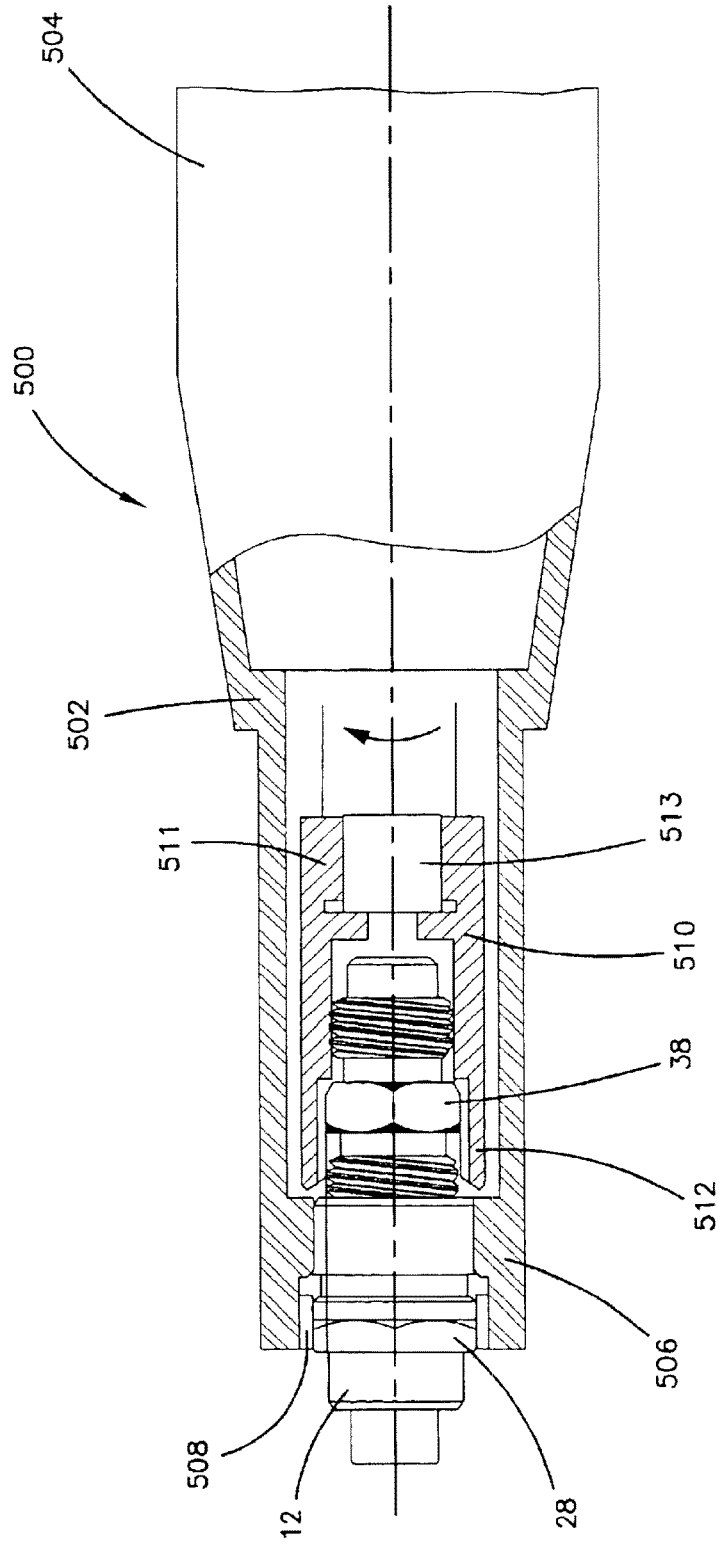

FIG. 10C

FIG. 11



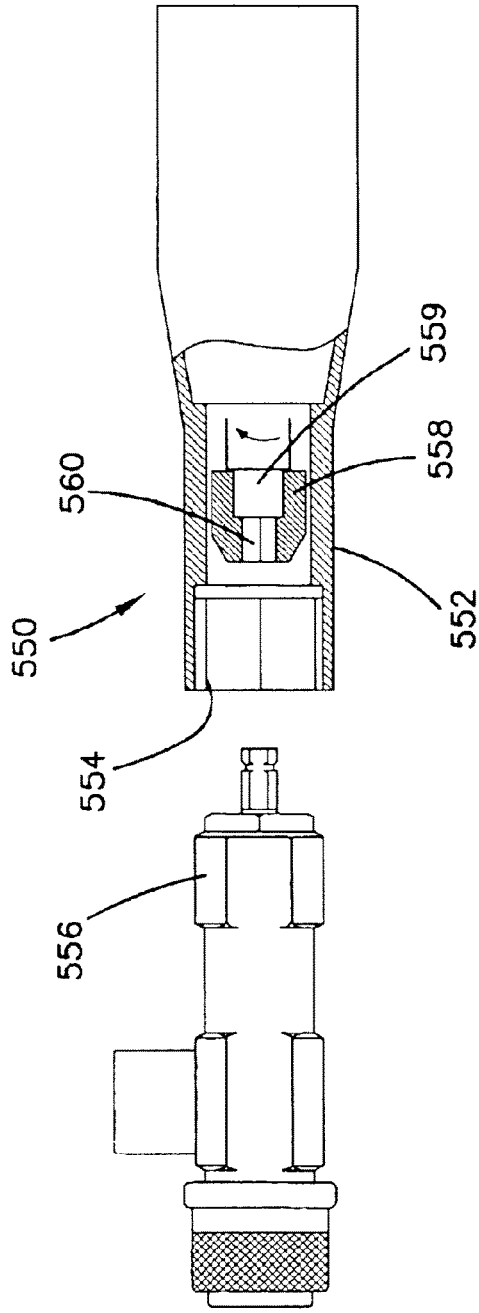

FIG. 12A

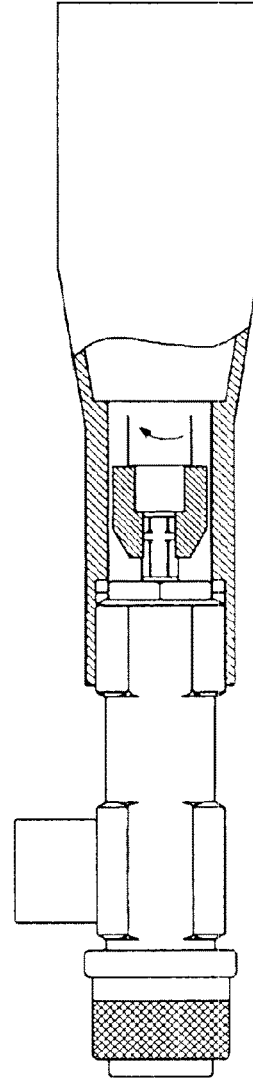

FIG. 12B

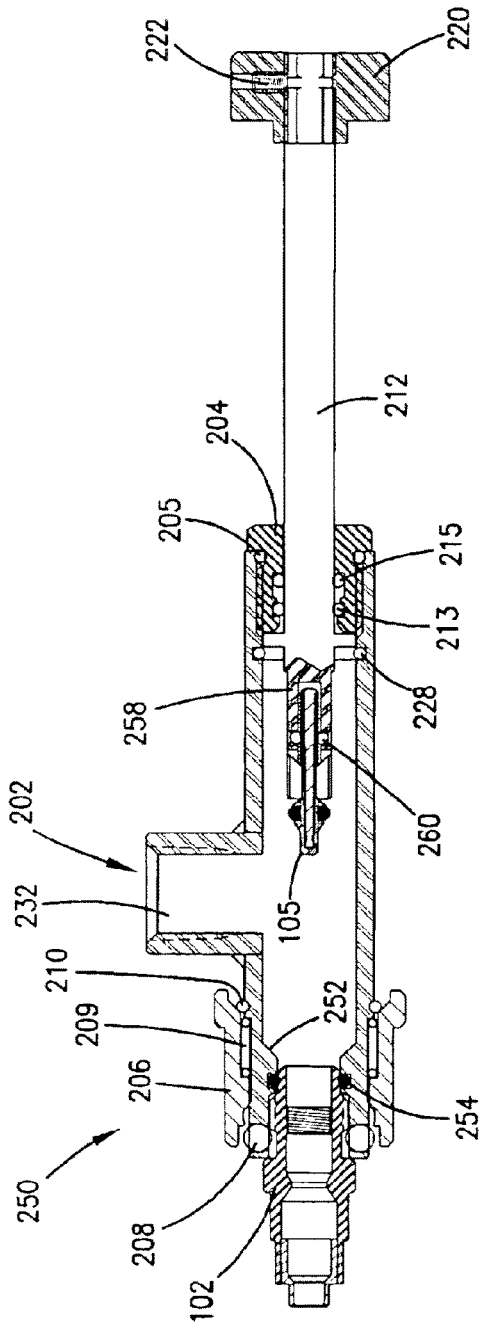

FIG. 13A

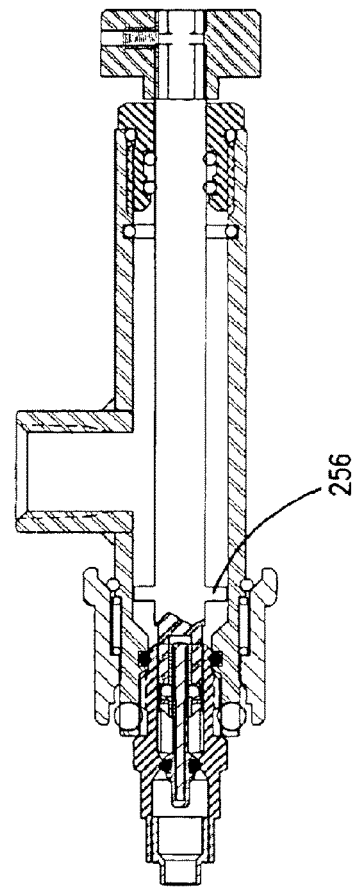
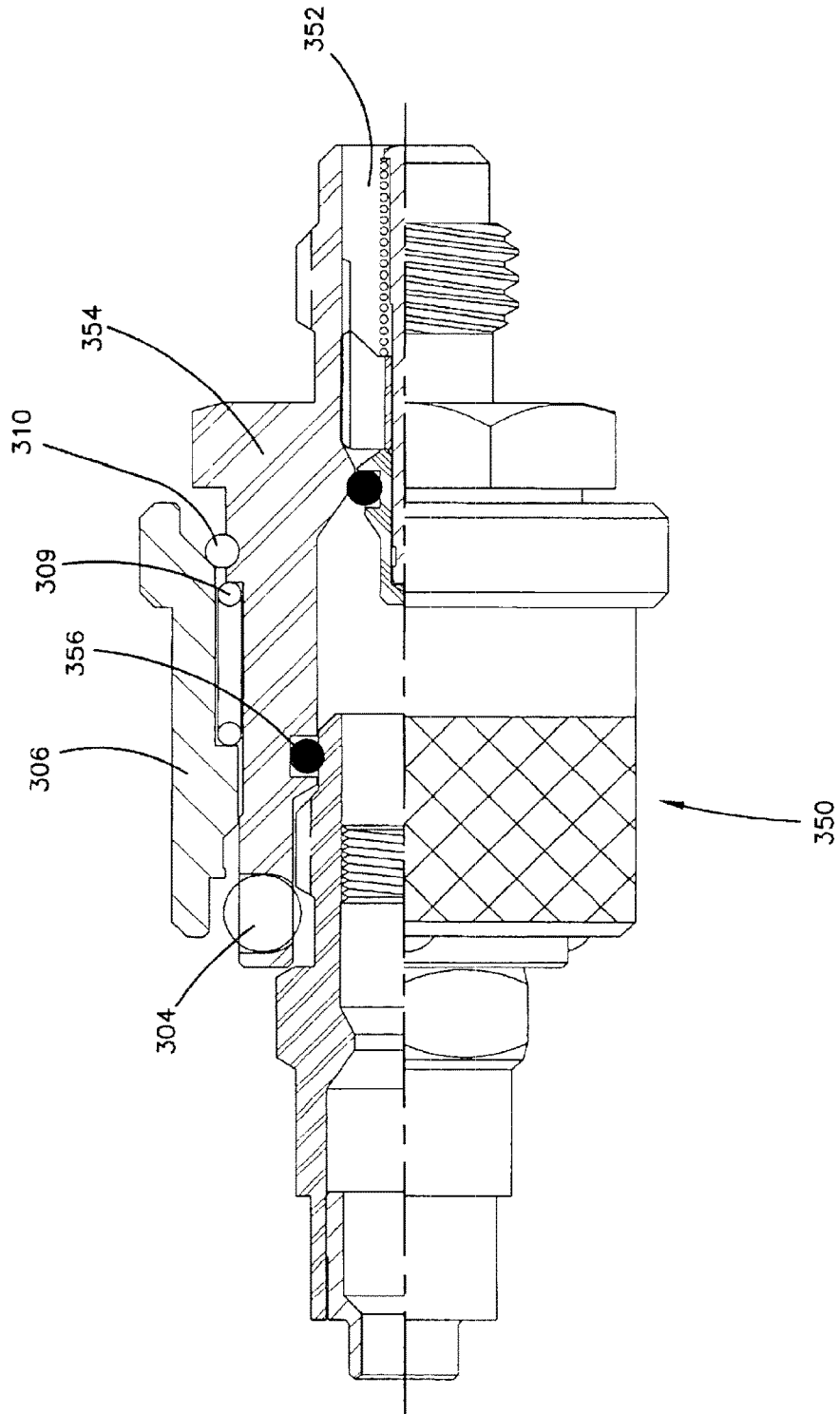

FIG. 13B

FIG. 14



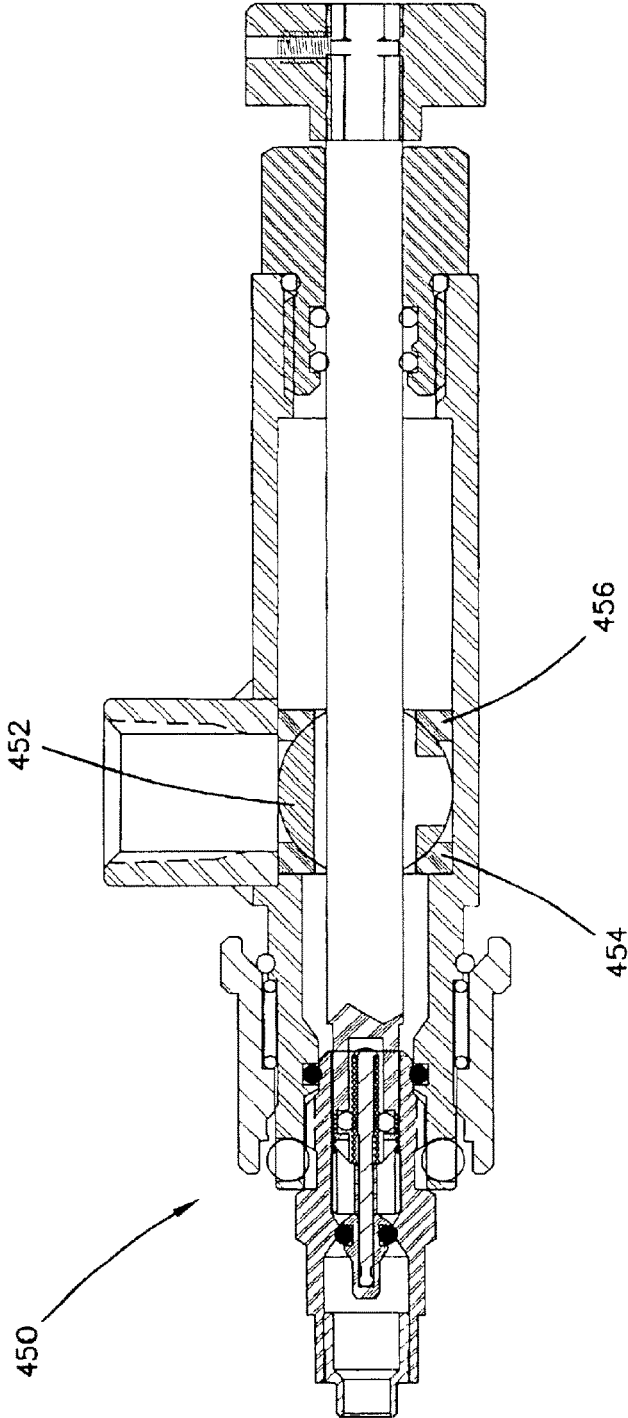

FIG. 15

**RAPID EVACUATION AND CHARGING
SYSTEM, AND APPARATUS AND METHODS
RELATING THERETO**

Matter enclosed in heavy brackets [] appears in the original patent but forms no part of this reissue specification; matter printed in italics indicates the additions made by reissue; a claim printed with strikethrough indicates that the claim was canceled, disclaimed, or held invalid by a prior post-patent action or proceeding.

This application claims the benefit of U.S. Provisional Application No. 60/246,796, filed Nov. 8, 2000.

FIELD OF THE INVENTION

The present invention relates generally to refrigeration systems, such as air conditioning units, refrigerators, and like products that utilize a refrigerant for cooling. More particularly, the present invention relates to a system to achieve rapid charging and/or evacuation of such systems, as well as to apparatus and methods relating thereto.

BACKGROUND OF THE INVENTION

Refrigeration products, such as air conditioning units and the like, employ a refrigerant contained in a closed loop system to provide cooling. Access to the closed loop system is commonly provided by a service connection, or service valve block. The service connection is valved to permit charging, evacuation, and/or testing of the closed loop system for a variety of purposes by manufacturing personnel during manufacture or by service personnel in the field.

A desirable feature of a service connection valve of a refrigeration product is the ability to permit high flow rates both into the closed loop system during charging as well as high flow rates out of the closed loop system during evacuation. In addition to permitting high flow rates, the valve should also be replaceable in the event of a failure of one or more of the valve components, such as a seal.

FIG. 1 illustrates a typical process that the cooling system of a refrigeration product undergoes during manufacturing. The system is first pressurized for testing purposes, during which a burst test followed by a leak test are performed. The tests can be performed either at a single testing station, or at separate stations. A typical total testing time takes from about 2 to about 5 minutes. After testing, the system is vented to atmosphere, followed by an evacuation. Evacuation typically takes from about 10 to about 30 minutes. Once evacuation is complete, the system is charged, which typically takes about 2 minutes, followed by another leak test during which the system is checked for leaks, and a subsequent run test. Each processing phase is often performed at a separate station, or one or more processing phases are performed at a single station. As evident from FIG. 1, the evacuation phase accounts for the largest percentage of the total processing time, and any reduction in evacuation time, thereby reducing the total processing time, would be beneficial. Any reduction in the other processing phase times would also be beneficial.

In addition, service personnel in the field access the cooling system of the refrigeration product through the service connection valve, typically for charging or evacua-

tion of the cooling system. A reduction in charging or evacuation time would also benefit service personnel as well.

High flow valves having high flow rates are disclosed in U.S. Pat. No. 6,050,295. This patent also discloses a service connection that utilizes a valve core, often called a schrader valve, for controlling access to a closed loop cooling system of a refrigeration system. As described in the patent, the flow rate provided by a schrader valve core is generally lower than the flow rates provided by the high flow valves disclosed in the patent. It is expected that the valves described in U.S. Pat. No. 6,050,295, when used on a refrigeration product, would permit a reduction in one or more of the processing phase times during manufacturing, as well as reducing charging and evacuation times for service personnel.

Manufacturing and service personnel also rely upon a variety of tools during manufacturing and servicing to connect with a service connection valve to provide access to the cooling system in order to conduct each processing phase. For example, valve core removal tools for removing and/or inserting schrader valve cores are available from Robinair of Montpelier, Ohio. These valve core removal tools utilize a screw thread coupling mechanism at one end thereof that screws onto threads on the schrader valve body for connecting the tool to the valve. However, it is expected that improved tooling will also facilitate the manufacturing and service processing phases.

There is a need for improvements in the manufacturing and service processes on refrigeration systems to reduce the overall time of the processes, as well as to make such processes easier on manufacturing and service personnel.

SUMMARY OF THE INVENTION

The invention provides a system for performing rapid charging and evacuation of systems that contain a fluid, such as cooling systems on refrigeration products. In addition, the invention relates to methods of accomplishing rapid charging and evacuation, as well as to tools that form part of the system and that are used to accomplish the methods.

In one aspect of the invention, a system for charging or evacuating a closed loop fluid system comprises a service connection valve adapted to be connected to the system. The service connection valve includes a valve seat adapted to be fixed to the system and a valve core that is adapted to be removably connectable to the valve seat. The system further includes a service tool that is connectable with the valve seat and which includes a port through which charging or evacuating operations can occur.

In another aspect of the invention, a method for charging or evacuating a closed loop fluid system is provided. The method includes attaching a service connection valve to the system, where the service connection valve includes a valve seat fixed to the system and a valve core that is removably connected to the valve seat. The method further includes removing the valve core from the valve seat, and charging or evacuating the system through the valve seat.

In another aspect of the invention, a tool to insert or remove a valve core into or from a valve seat is provided. The tool comprises a generally hollow body having an open end, a closed end, and a port positioned between the open and closed ends that can be placed in flow communication with the open end. Means adjacent the open end of the body releasably connects the body to the valve seat, and a socket within the body holds and retains the valve core. The socket is mounted for movement within the hollow body along a

longitudinal axis of the body between a first position adjacent the open end and a second position adjacent the closed end of the body.

In yet another aspect of the invention, a coupling for conducting servicing operations through a valve seat is provided. The coupling comprises a body having first and second open ends and a flow path extending through the body between the first and second ends. Means associated with the first open end of the body releasably connects the body to the valve seat, and a valve associated with the second open end of the body controls flow through the second open end.

In still another aspect of the invention, a tool that is attachable to a pneumatic gun for inserting or removing a valve core into or from a valve seat is provided. The tool comprises a holding head with a first end adapted to connect to a housing of the pneumatic gun and a second end formed with an internal hex. The tool also includes a drive head disposed within the holding head. The drive head includes a first end adapted for connection to a drive element of the pneumatic gun and a second end provided with a socket for driving the valve core.

A variety of additional advantages of the invention will be set forth in part in the description which follows, and in part will be apparent from the description, or may be learned by practice of the invention. The advantages of the invention will be realized and attained by means of the elements and combinations particularly pointed out in the claims. It is to be understood that both the foregoing general description and the following detailed description are exemplary and explanatory only and are not restrictive of the invention as claimed.

BRIEF DESCRIPTION OF THE DRAWINGS

FIG. 1 illustrates a typical process that a cooling system of a refrigeration product undergoes during manufacturing.

FIG. 2 is a partial cross-sectional view of a high flow service connection valve.

FIG. 3 is a cross-sectional view of a second embodiment of a high flow service connection valve.

FIG. 4 is a cross-sectional view of a tool for inserting a core into or removing a core from the service connection valve of FIG. 2.

FIGS. 5A-E illustrate the operation of the insertion tool.

FIG. 6 illustrates a coupling using the valve of FIG. 2.

FIG. 7 illustrates a second embodiment of a coupling using an alternative valve.

FIG. 8 is a cross-sectional view of the coupling of FIG. 6, with the valve removed, illustrating the details thereof.

FIG. 9 is a cross-sectional view of a tool for removing a core from or inserting a core into the service connection valve of FIG. 2.

FIGS. 10A-C illustrate the operation of the tool of FIG. 9.

FIG. 11 illustrates a torque tool for removing or inserting a core of the service connection valve of FIG. 2.

FIGS. 12A-B illustrate a torque tool operating with the core insertion or removal tool.

FIGS. 13A and 13B illustrate a tool for inserting a core into or removing a core from the service connection valve of FIG. 3.

FIG. 14 illustrates a valved connector for use with the service connection valve of FIG. 3.

FIG. 15 illustrates a tool for removing a core from or inserting a core into the service connection valve of FIG. 3.

DETAILED DESCRIPTION OF THE PREFERRED EMBODIMENTS

The invention relates to systems and methods for rapid evacuation, charging and/or testing of a system, such as a cooling system of a refrigeration product including air conditioning units, refrigerators and the like. The invention also relates to tooling used in such systems, as well as to methods relating thereto. The systems, methods and tooling aid both manufacturing and service personnel in performing evacuation, charging and testing operations.

The term "charging" as used herein includes the addition of a fluid into the system, whether the system is either completely empty of fluid or already contains fluid. The term "evacuation" as used herein includes the removal of portions of the fluid, or the entire amount of fluid, from the system. The term "testing" can include either charging or evacuation, as well as interactions with the system, such as pressure testing, whereby no fluid is added or removed. The term "processing" is meant to encompass charging, evacuation, testing and like interactions with the system.

Service Connection Valves

With reference to FIG. 2, one embodiment of a service connection valve 10 is illustrated. This valve is similar to valves disclosed in U.S. Pat. No. 6,050,295 and U.S. application Ser. No. 09/975,911 filed on Oct. 11, 2001 (now abandoned), which claims priority from U.S. Provisional Application No. 60/241,758, the disclosures of which are incorporated herein by reference.

The valve 10 is comprised of three primary components: a valve seat 12, a valve body 14, and a valve assembly 16. The valve seat 12 and valve body 14, which are formed from a metal such as brass, cooperate together to define a flow path through which a fluid, such as a refrigerant, is able to flow. The valve assembly 16 controls fluid flow through the valve 10. The valve body 14 and valve assembly 16 together form what will be referred to as a core 17 which can be removed from the seat 12.

The valve seat 12 is generally cylindrical and includes a first end region 20 that is illustrated as having a diameter that is reduced compared with the remainder of the valve seat. It is to be realized that the end region 20 could have a diameter that is about equal to, or greater than, the remainder of the valve seat 12, the diameter of the end region 20 being dependent upon the system to which the valve seat connects to. In the preferred use, the valve seat 12 is fixed to the refrigeration product in fluid communication with its closed loop cooling system by suitably securing the end region 20 to the refrigeration product, such as by brazing or welding, or by using threads. A central passage 22 defined by an interior wall 24 of the valve seat 12 extends from the first end region 20 to a second end region 26 of the valve seat. The seat 12 includes a hex head 28 formed thereon, and a cylindrical detent groove 30 is provided to facilitate engagement by a connector, such as a latching ball connector. Moreover, the interior wall 24 of the seat 12 is provided with threads 32 adjacent the end region 26.

The valve body 14 is also generally cylindrical, and includes an end region 34 that in use is disposed within the end region 26 of the seat 12. The end region 34 is provided with threads 36 that engage with the threads 32 on the seat 12 whereby the valve body 14 can be secured to, and detached from, the seat 12. A hex head 38 is also formed on the valve body 14 and abuts against the end region 26 of the seat 12 to limit insertion of the valve body. Threads 40 on the

exterior surface of the valve body **14** permit screwing of an end cap **39** onto an end region **42** of the valve body. The valve body **14** further includes a channel **41** defined behind the threads **40**.

A central passage **44** defined by an interior wall **46** of the valve body **14** extends from the end region **34** to the end region **42** of the valve body. The passage **44** is aligned with the passage **22** in use and the two passages **22**, **44** combine to form a flow path for fluid through the valve **10**.

The valve assembly **16** is supported within the body **14** so as to form a part thereof such that when the body **14** is removed from the seat **12**, the valve assembly is removed therewith. The valve assembly **16** includes an elongated valve stem **50** extending through the passage **44** parallel to the longitudinal axis thereof and a valve head **52** is secured to one end of the valve stem.

A spacer **54** is fixed within the passage **44** for slideably supporting the valve stem **50** to allow opening and closing movements of the valve stem and head. The spacer **54** includes a central sleeve **56** through which the valve stem **50** extends, and a plurality of spacer arms are circumferentially spaced around the sleeve **56** and extend toward the interior surface of the body **14** for supporting the central sleeve. There are preferably two or three of the spacer arms in order to provide adequate support for the central sleeve **56**. The spacer **54** can either be removably or non-removably mounted in the passage **44**.

A coil spring **58** surrounds the valve stem **50** and is engaged between the sleeve **56** and an enlarged end of the valve stem so as to bias the valve head **52** into sealed engagement with a seal **60**, as well as with a lip **62** on the valve body **14** to provide a metal to metal seal as a back-up to the seal **60**. Thus, flow through the valve **10** is prevented until the valve stem is biased, against the bias of the spring **58**, to unseat the valve head.

With reference to FIG. 3, a second embodiment of a service connection valve **100** is illustrated. The service connection valve **100** utilizes a one-piece valve body **102** rather than a separate valve seat and valve body as in FIG. 2. Service connection valves using a one-piece body are disclosed in U.S. Pat. No. 6,050,295 and U.S. application Ser. No. 09/975,911 (now abandoned), which claims priority from U.S. Provisional Application No. 60/241,758, the disclosures of which are incorporated herein by reference.

The exterior construction of the one-piece body **102** is similar to exteriors of the valve seat **12** and valve body **14** of FIG. 2. A valve assembly **104** is supported within the one-piece body **102** for controlling flow therethrough. The valve assembly **104** in this embodiment forms what will be referred to as a core **105**, which can be removed from the body **102**, with the body **102** forming what can be referred to as a valve seat for the core **105**. The valve assembly **104** includes a valve stem **106**, a valve head **108** and a spacer **110**.

The arms of the spacer **110** are formed with threads, that are designed to engage with a threaded section **112** formed on the interior wall of the one-piece body **102** adjacent to a reduced diameter valve seat portion **116**. The valve assembly **104**, via the spacer **110** and the threads **112**, can thus be inserted into and removed from the body **102**.

The body **102** also includes a threaded section **118** and a circumferential detent groove or channel **120** defined between the threaded section **118** and a hex head **122**. A latching connector can latch onto the body **102** by engaging with the channel **120** or with the threads of the threaded section **118**.

As used herein, the term "latching connector" refers to a connector that is designed to latch or clamp onto the seat **12** or body **102** to securely hold the tool to the seat **12** or body **102**. Examples of latching connectors include latching ball connectors, examples of which are disclosed in U.S. Pat. Nos. 6,039,303 and 6,073,974, and split collet connectors, an example of which is disclosed in U.S. Pat. No. 6,039,303. A latching ball connector will interact with the circumferential detent groove provided in the seat **12** or body **102**, while a split collet connector will interact with or slightly behind threads provided on the exterior surface of the seat **12** or body **102**.

Core Insertion/Removal Service Tool

FIGS. 4 and 5A-E illustrate a service tool **200** that is used to insert a core, i.e. valve body **14** and valve assembly **16**, into the valve seat **12** of the valve **10** in FIG. 2. The tool **200** can also be used to remove the core from the valve seat **12**, particularly when the system to which the valve **10** is connected is not pressurized. The tool **200** includes a generally cylindrical, hollow body **202**, that is open at one end, and at the opposite end is closed by a cap **204** that is preferably threaded into the end of the body **202**. An o-ring **205** seals between the cap **204** and the body **202**.

A connection means to permit connection to the valve seat **12** is disposed adjacent the open end of the body **202**. In the preferred embodiment, the connection means comprises a cylindrical sleeve **206** that is slidably disposed on the end region of the body **202**. A plurality of balls **208** are disposed within circumferentially spaced holes formed in the end region of the body **202**, and are actuated by the sleeve **206** in known fashion to connect to the seat **12**. The sleeve **206** is biased by a spring **209** toward a direction in which the balls are forced by the sleeve **206** down into their respective holes. A retaining ring **210**, disposed around the body **202**, limits the rearward movement of the sleeve **206** on the body. The interior of the body **202** is provided with a hex **211** that is designed to engage with the hex head **28** on the valve seat **12**.

A shaft **212** slidably and rotatably extends through the cap **204** and into the hollow body **202**. A pair of o-rings **213**, **215** seal between the shaft **212** and the cap **204**. One end of the shaft **212** is formed into, or has connected thereto, a socket **214**. Disposed within the socket **214** is a split collet core retainer **216** that is retained within the socket by a clip **218**. Further, the interior of the socket **214** adjacent the open end thereof is formed into an internal drive hex **219** to engage a hex head on the valve core, and the closed end of the socket **214** is provided with an exterior raised shoulder **221**.

The opposite end of the shaft **212** has connected thereto a knob **220** using a set screw **222** or the like. Moreover, a pair of seals **224**, **226** are disposed within circumferential grooves formed in the inner surface of the body adjacent the balls **208**, and a locking o-ring **228** is disposed within a circumferential groove formed in the inner surface of the body **202** adjacent the cap **204**.

The operation of the tool **200** to insert a core is as follows. The sleeve **206** is initially biased forward up against the balls **208** by the spring **209**. With reference to FIG. 5A, the sleeve **206** is pulled back and the shaft **212** is pushed completely forward, thereby exposing the collet **216** and the drive hex **219**. The core (i.e. the valve body **14** and valve assembly **16**) that is to be torqued into the seat is then inserted into the socket **214** by hand or otherwise, with the core being retained by the collet **216** and the drive hex **219** engaging the hex head **38** on the valve body **14**, as illustrated in FIG. 5B.

The shaft 212 is then pulled back, as shown in FIG. 5C, and the shaft is held in this position by the shoulder 221 and locking o-ring 228. Referring to FIG. 5D, the tool 200 is then attached to the valve seat 12 by pulling back on the sleeve 206 and allowing the balls 208 to move over the outer diameter of the seat 12 until they reach, and are forced into, the detent groove 30 on the seat by releasing the sleeve 206. The seals 224, 226 seal with the exterior surface of the seat 12 to prevent leakage. Finally, the core is torqued into the seat 12 by pushing the shaft 212 forward and threading the core into the seat, as illustrated in FIG. 5E. Core removal should be apparent from the description of the core insertion.

During use of the tool 200, the hex 211 engages the hex head 28 on the seat 12 and the drive hex 219 engages the hex head 38. As a result, the seat 12 is held by the body 202 and prevented from rotating as the core 17 (i.e. the body 14 and valve assembly 16) is inserted into (or removed from) the seat 12.

The body 202 is shown in the figures as including a port 232 through which a fluid can flow either into or out of the body. The port 232 allows the tool 200 to be connected to the seat 12 and thereafter for processing (i.e. evacuation, charging, testing, etc.) to occur through the tool 200. Processing would normally occur after the tool 200 is connected to the seat 12 and the shaft 212 has been pulled backward as shown in FIG. 5D. Once processing is completed, the shaft is pushed forward (see FIG. 5E), and the core inserted into the seat to thereby close the system. FIG. 5E illustrates the knob 220 as being removed from the shaft 212. Removal of the knob 220 permits the use of a tool, such as the torque tool later described herein, to be used to torque the core into the valve seat.

FIGS. 13A and 13B illustrate a service tool 250 that is used to insert the core, i.e. the valve assembly 104, of the service connection valve 100 of FIG. 3. Like the tool 200, the tool 250 can also be used to remove the core from the valve seat. The tool 250 is in many ways similar to the tool 200, and like elements will be referenced using the same reference numbers. One difference is that the body 202 is provided with an internal reduced diameter portion 252 provided with an o-ring seal 254 that seals with the exterior of the one-piece body 102. The threads on the exterior of the one-piece body engage the reduced diameter portion 252 and limits its insertion into the body.

Further, the shaft 212 is provided with a flange 256 adjacent a socket 258. The flange 256 cooperates with the locking o-ring 228 to retain the shaft 212 once it is pulled back, as shown in FIG. 13A. Further, the flange 256 slides along the inner surface of the body and stabilizes the shaft 212 during its movements.

The socket 258 is substantially smaller than the socket 214, as the socket is designed to receive and hold the valve stem 106 of the core. The socket 258 is provided with an internal o-ring 260 which surrounds and frictionally retains the stem 106 when it is inserted into the socket 258, as shown in FIG. 13A. Retainers other than an o-ring could be used as well.

The operation of the tool 250 is similar to the operation of the tool 200 and a detailed explanation of the operation of the tool 250 is therefore not necessary. It is to be understood that the torque tool (to be later described) is also used with the tool 250.

Valved Coupling

FIG. 6 illustrates a coupling 300 that is provided with a core 17', such as the core (i.e. valve body and valve

assembly) from the service connection valve of FIG. 2. Alternatively, FIG. 7 illustrates a coupling 300' with a National Pipe Thread NPT) 302 connected thereto, and a valved quick coupling, such as a Production Control Unit (PCU) valve or a Parker valve, connected to the NPT, to accommodate a hose or fitting. The couplings 300, 300' are designed to latch onto the valve seat 12 using latching balls 304 that engage in the detent groove 30 of the seat 12. The couplings 300, 300' provide a temporary valve for the seat 12 when the core 17 is not present.

FIG. 8 illustrates the details of the coupling 300, with the core 17' removed for clarity. The coupling 300 includes a connection means that is similar to the connection means in FIG. 4, including a sleeve 306 that is slideably disposed on a body 308 having first and second open ends and a flow path between the ends. The sleeve 306 is biased by a spring 309 toward a direction in which the balls 304 are forced by the sleeve 306 down into their respective holes. A retaining ring 310, disposed around the body 202, limits the rearward movement of the sleeve 306 on the body 308. In addition, a pair of seals 312, 314 disposed in grooves formed in the interior of the body 308 seal with the exterior surface of the seat 12 to prevent fluid leakage. The operation of the coupling 300 and how it connects to the seat 12 should be apparent from the discussion of the tools 200, 250, and further description of the operation is not provided.

It should be apparent that once the coupling 300 is connected to the seat 12, the valve core 17' in the coupling 300 valves the seat 12 and prevents escape of working fluid. Any processing operations can then be carried on through the coupling 300 by connecting a suitable processing line to the end of the valve core 17' by using a latching connector to engage the channel 41' or the threads 40'. Further, the hex head 38' is accessible for engagement by a corresponding hex on a tool as described herein. Connection of a processing line to the valve core opens the valve associated with the core to permit flow through the coupling 300. The coupling 300' is constructed and operates in similar fashion to the coupling 300.

FIG. 14 illustrates a coupling 350 for use with the one-piece body 102 of the service connection valve 100 of FIG. 3. The coupling 350 is provided with a valve assembly 352, identical to the valve assembly 104, to control flow through the coupling 350. Alternatively, an arrangement as in FIG. 7 could be used on the coupling 350 in place of the valve assembly 352.

The coupling 350 is similar to the coupling 300 and similar elements will be referenced using the same reference numerals. The body 354 of the coupling 350 has a greater axial length than the body 308 of the coupling 300 to accommodate the valve assembly 352. A seal 356 seals with the exterior surface of the one-piece body 102. The latching balls 304 latch in the channel 120 behind the threaded section 118 on the exterior of the body 102. As an alternative to latching balls, a split collet assembly that latches onto or behind the threaded section 118 could be used as well.

Core Removal/Insertion Service Tool

FIGS. 9 and 10A-C illustrate a service tool 400 that is used to remove a core from the valve 10 in FIG. 2 while the system to which the valve 10 is attached is pressurized, as well as insert the core into the valve. As can be seen from FIGS. 9 and 10A-C, many elements of the tool 400 are substantially identical to elements of the tool 200, and like elements are referenced using the same reference numerals.

Because the tool **400** connects to a pressurized system, the tool **400** must be designed to prevent fluid escape from the system when the core is removed. To accomplish this, a ball valve **402** is disposed in the body **202**. The ball **402** is rotatably supported by a pair of Teflon seats **404**, **406** disposed in the body. A passage **407** is formed through the ball **402**, with a first section **408** of the passage having a diameter that is sufficient to allow passage of the shoulder **221** and socket **214** when the axis of the section **408** is aligned with the axis of the shaft **212** and when the shaft **212** is pulled backward. A second section **410** of the passage is selectively alignable with the open end of the body **202** by rotating the ball **402**, as illustrated in FIG. **10B**.

The ball **402** is connected to a handle (not shown) disposed exteriorly of the body **202** by which the ball is rotated between a first position, shown in FIG. **9**, and a second position, shown in FIG. **10B**. In the first position of the ball **402**, flow through the tool **400** is prevented and the section **408** is generally aligned with the shaft **212**. In the second position, the section **410** faces the open end of the body **202** while the section **408** communicates the port **232** with the open end of the body. The ball **402** is rotatable about an axis that is perpendicular to the shaft **212** and perpendicular to the axis of the port **232**.

In the tool **400**, the body **202** is comprised of a front body **412** and a rear body **414** detachably connected to the front body, preferably by threading the rear body **414** into the front body **412**. The seats **404**, **406** seal and prevent fluid leakage from between the front and rear bodies, and a snap ring **416** retains the seats **404**, **406** within the front body. In addition, a clip **418** retains the rear body **414** within the front body **412**. This construction permits assembly of the seats **404**, **406** and ball **402** into the tool **400**, as well as replacement of the seats and ball if the need arises.

The operation of the tool **400** is illustrated in FIGS. **10A-C**. As indicated, the tool **400** is designed for use with the valve **10** that is attached to a pressurized system. Initially, the tool **400** is attached to the valve **10**, as shown in FIG. **10A**, by latching onto the detent groove **30** of the seat **12**. At this stage, the hex **211** engages the hex head **28** on the seat **12**, the seals **224**, **226** seal with the exterior of the seat **12**, the drive hex **219** engages the hex head **38** on the body **14**, and the collet **216** grips and retains the core. The knob is not attached to the shaft **212** to permit use of the torque tool, later described, to thread the core out of the seat **12**. Once the core is threaded out, the shaft **212** is pulled backward, as shown in FIG. **10B**, thereby pulling the core into the rear body **414**. The ball valve **402** is then rotated 90 degrees to its second position to allow flow through the port **232** and into and through the seat **12**. In this position, the ball valve **402** also closes off flow to the core disposed in the rear body **414**. After the ball valve **402** is rotated, the shaft **212** along with the core held thereby can be removed from the tool **400** as shown in FIG. **10C**. The core, either the same core or a new core, can thereafter be inserted by simply reversing the process used to remove the core.

FIG. **15** illustrates a service tool **450** for removing the core from the service connection valve **100** of FIG. **3** as well as inserting the core into the valve **100**. The tool **450** is substantially identical to the tool **250** of FIGS. **13A-B**, and similar elements are referenced using the same reference numerals. However, the tool **450** includes a ball valve **452** and ball valve seats **454**, **456** that are similar to the ball valve and valve seats in FIG. **9**. Moreover, the shaft **212** is not provided with the flange **256** that was used in the embodiment of FIGS. **13A** and **13B**, to permit the shaft and the valve core held thereby to be pulled backward through the

ball valve **452**. The tool **450** functions similarly to the tool **400**, and is therefore not further described.

Torque Tool

FIG. **11** illustrates a tool **500** that is used to either insert a core into or remove a core from the valves **10** and **100**. The tool **500** is not used with any of the tools **200**, **250**, **300**, **350**, **400**, **450**. Instead, the tool **500** acts directly on the cores of the valves **10**, **100**. The tool **500** is designed to attach to a conventional pneumatic gun (not shown) or the like, and is operated by the pneumatic gun.

The tool **500** includes an elongated, generally cylindrical external holding head **502** with a first end region **504** that is designed to fit over the housing of the pneumatic gun to attach the head **502** to the gun, and an end region **506** that engages with the valve seat **12**. The end region **506** includes an internal hex **508** that engages with the hex head **28** of the seat **12**. The holding head **502**, when attached to the pneumatic gun, holds the seat **12** against rotation.

The tool **500** further includes an elongated, generally cylindrical internal drive head **510** that is disposed longitudinally within the holding head **502**. The drive head **510** includes an end **511** that connects to the drive element **513** on the pneumatic gun, preferably via a standard socket connection. Therefore, when the drive element **513** rotates, the drive head **510** is also rotated, with the holding head **502** remaining stationary. The other end of the drive head **510** is constructed as a socket having an internal diameter that is sized to permit the drive head **510** to slide over, and drive, the valve core. The socket of the drive head **510** includes an internal hex **512** that engages with the hex head **38** on the valve body **14**, so that the valve core is able to be rotated by the drive head **510**.

In use, the tool **500**, which has been attached to the pneumatic gun, is fit onto the valve **10** as illustrated in FIG. **11**. The gun is then actuated to rotate the drive head **510** to either insert or remove the valve core. A pneumatic gun, as is known in the art, typically includes a selector to permit the drive element of the gun to rotate in a first or second direction. Therefore, rotation of the drive head **510** in one direction will cause the valve core to be threaded into the valve seat **12**, while rotation of the drive head in the opposite direction causes the valve core to be unthreaded from the valve seat. Because the holding head **502** holds the seat **12**, no torque is transferred to the operator of the pneumatic gun or to the joint between the seat **12** and the product to which the seat **12** is connected.

FIGS. **12A-B** illustrates another torque tool **550** that attaches to a pneumatic gun or the like and which is designed for use with a core insertion or removal tool, such as the tools **200**, **250**, **400**, **450**. The tool **550** includes an external holding head **552** that has an internal hex **554** designed to engage with a hex **556** formed on the exterior of the body of the insertion or removal tool. The tool **550** also includes an internal drive head **558** that is driven by the drive element **559** of the pneumatic gun. The drive head **558** includes a socket **560** that is designed to engage with, and drive, the end of the shaft **212** from which the knob **220** has been removed. In operation, the holding head **552** holds the tool body while the drive head **558** drives the shaft **212**, and no torque is transferred to the operator of the pneumatic gun or to the joint of the seat **12**.

Processing and System Operation

Referring once again to FIG. **1**, it was earlier described herein that the processes and tests shown therein are often

11

performed at separate stations. A typical process flow that a refrigeration product undergoes is as follows:

- Station 1 ⇒ Burst Test
- Station 2 ⇒ Rough Leak test
⇒ Vent to Atmosphere
- Station 3 ⇒ Rough Evacuation
- Station 4 ⇒ Final Evacuation
- Station 5 ⇒ System Charged (with refrigerant)
- Station 6 ⇒ Leak Test
- Station 7 ⇒ Run Test

The system of the invention will be described in relation to this typical process flow. It is to be realized that the process is exemplary, and that the system of the invention could be used with other process flows. Given this typical process flow, there are at least three different scenarios by which the system of the invention could be utilized.

Scenario 1

At station 1, a valve core is inserted into the tool 200, 250. The tool is then attached to the valve seat 12 (or body 102) which has been previously affixed to the refrigeration product. The tool stays with the product through station 4. Therefore, the burst test, the rough leak test and venting to atmosphere, the rough evacuation and the final evacuation all occur with the tool 200, 250 in place, and any fluid flow occurs through the port 232. In this scenario, a valved quick connection, such as a PCU or a Parker valve, must be connected to the port 232 to prevent flow therethrough while the product moves between stations, and to permit connection with a processing line at each station. After the final evacuation is finished, the valve core is inserted into the seat using the tool 200, 250 and the torque tool 550, and the tool is then removed. The product, which is now valved by a complete valve 10, 100, proceeds to station 5 where it is filled with refrigerant. Preferably, the refrigerant processing line at station 5 is provided with a connector to permit connection to the valve 10, 100. A suitable connector is disclosed in U.S. Pat. No. 6,039,303. As described in this patent, the connector is designed to latch onto the valve and open the valve assembly within the valve. Once the system is charged with refrigerant, the product proceeds to stations 6 and 7 for a leak test and run test, respectively. No tools of the system are used at stations 6 and 7. However, at station 7, a connector, such as a connector disclosed in U.S. Pat. No. 6,039,303, is used to connect to the system for monitoring parameters such as pressure and temperature during the run test.

A benefit provided by this scenario is that maximum flow is achieved at every station. Notably, when the valve core is removed from the valve seat, flow occurs through the valve seat unrestricted by the valve core. Further, when the valve core is inserted, the high flow benefits provided by the valves 10, 100 are achieved. Another benefit of this scenario is that if the rough evacuation and final evacuation are at different stations, there is no loss in vacuum as the product moves from station 3 to station 4.

Scenario 2

At station 1, a connector, such as the coupling 300 of FIG. 6, is attached to the valve seat 12 (or body 102) which has been previously affixed to the refrigeration product. Using an additional connector, such as the connector in U.S. Pat. No. 6,039,303, the burst test is performed. The coupling 300 then stays with the product through station 2. After station 2, the coupling 300 is removed and the system is allowed to vent to atmosphere. The product then proceeds to a station that combines the evacuations of stations 3 and 4 mentioned above. The tool 200, 250 is attached to the seat 12 at this station, and evacuation occurs through the port 232, to

12

provide maximum flow into and out of the system. Once evacuation is complete, the valve core is installed using the tool 200, 250 and the tool 550. After the valve core is installed, the product is moved to station 5 for charging. Again, a connector from U.S. Pat. No. 6,039,303 can be used to perform the charging. After charging, the product proceeds to stations 6 and 7 for further processing as in scenario 1.

A benefit provided by this scenario is that maximum flow is achieved during evacuation. The evacuation requires the most amount of time to complete, and therefore increasing flow rate permits a reduction in evacuation time. In addition, the only tool that moves with the product down the processing line is the coupling 300. Since each product has a coupling 300 in this scenario, a relatively large number of couplings at station 1 are needed. However, the coupling 300 is a relatively inexpensive tool, and therefore it is more economically feasible to have the large quantity of couplings 300 that are needed at station 1.

Scenario 3

At station 1, a valve 10, 100 is inserted, using the tool 200, 250, into the valve seat 12 (or body 102) which has been attached to the product. The core of the valve is then torqued into the seat using the tool 500. A connector, such as a connector disclosed in U.S. Pat. No. 6,039,303, is present at station 1 to connect to the valve to perform the burst test. Likewise, stations 2-5 each include a connector like that disclosed in U.S. Pat. No. 6,039,303 to perform their respective processing. After charging, the product proceeds to stations 6 and 7 for further processing as in scenario 1.

A benefit of this scenario is that none of the tools of the system move with the product down the processing line. Therefore, numerous tools are not required.

In each of scenarios 1, 2 and 3, the tool 400 or 450 could be used in place of the tool 200, 250. Use of the tool 400, 450 would also be required if there is a leak in the valve core and the core requires replacement. This could occur either during manufacturing, such as during the processing at one of the stations 1-7, or in the field during use of the product.

Further, use of the tool 550 would be required any time the valve core is inserted into the seat 12 using the tool 200, 250, 400, 450. In contrast, the tool 500 would be used any time the valve core is directly inserted into the valve seat 12 without any additional tools, such as by hand. Hand tools, such as wrenches and the like, could also be used to insert the valve core into the valve seat.

The above specification, examples and data provide a complete description of the manufacture and use of the composition of the invention. Since many embodiments of the invention can be made without departing from the spirit and scope of the invention, the invention resides in the claims hereinafter appended.

We claim:

1. A system for performing processing operations on a closed loop fluid system, comprising:
 - a service connection valve adapted to be connected to the closed loop fluid system, the service connection valve including a valve seat adapted to be fixed to the closed loop fluid system and a valve core that is adapted to be removably connectable to said valve seat, and said valve seat includes an exterior surface portion comprising a detent groove to permit connection with a latching connector; [and]
 - the valve seat includes a hex head;*
 - the valve core includes a valve body and a valve assembly within the valve body, the valve core is removably*

13

attached to the valve seat via first threads, and the valve core includes a hex head; and

a service tool that is connectable with said valve seat, said service tool including:

- a) a latching connector that is engageable with said exterior surface portion for connecting said service tool to said valve [seat] seat;
- b) a removal/insertion mechanism that is capable of engaging said valve core so as to permit removal of said valve core from, or insertion of said valve core into, said valve seat; and
- c) a port through which fluid flow can occur.

[2. A system according to claim 1, wherein said valve core comprises a valve body adapted to be detachably connected to said valve seat, and a valve assembly connected to said valve body.]

3. A system according to claim [2] 1, wherein said valve assembly is detachably connected to said valve body.

[4. A system according to claim 1, wherein said valve seat comprises a one-piece body, and said valve core comprises a valve assembly adapted to be detachably connected to said one-piece body.]

5. A system according to claim 1, wherein said latching connector comprises a latching ball connector.

6. A system according to claim 1, wherein said exterior surface portion comprises threads.

7. A system according to claim 1, wherein [said valve seat comprises a hex head, and] said latching connector comprises a generally hollow body with an open end having a hex that is engageable with said hex head *of the valve seat*.

8. A system according to claim 7, wherein [said valve core includes a hex head, and] said removal/insertion mechanism includes a drive hex that is engageable with said hex head on said valve core.

9. A system according to claim 1, wherein said service tool further includes a valve for controlling fluid flow therethrough.

10. A system according to claim 1, wherein said removal/insertion mechanism includes a split collet assembly [or] for gripping said valve core.

11. A service tool for connecting to a valve seat and removing/inserting a valve core from/into the valve seat, comprising:

a generally hollow body having an open end, a closed end, and a port positioned between the open and closed ends;

a latching connector connected to said body adjacent the open end thereof to releasably connect said body to the valve seat, wherein said latching connector comprises a latching ball connector; and

a removal/insertion mechanism disposed within said body, said removal/insertion mechanism being movable within said hollow body along a longitudinal axis of said body between a first position adjacent the open end and a second position adjacent the closed end of said body;

said open end of said body has a hex.

12. A service tool according to claim 11, wherein said removal/insertion mechanism comprises a socket that is designed to hold and retain said valve core.

13. A service tool according to claim 12, further including a shaft connected to said socket, said shaft is oriented parallel to the longitudinal axis and extends through the closed end of said body to the exterior thereof.

14. A service tool according to claim 12, further including a valve mounted in said body between the open end and said port, said valve is mounted for movement between a first

14

position which prevents fluid communication between the open end and said port and a second position which permits fluid communication between the open end and said port.

15. A service tool according to claim 14, wherein said valve includes a passage therethrough that is sized to permit passage of said socket therethrough when said valve is at the first position.

[16. A service tool according to claim 11, wherein said open end of said body has a hex.]

17. A service tool according to claim [16] 11, wherein said removal/insertion mechanism includes a drive hex.

18. A service tool according to claim 12, wherein said socket includes a split collet assembly disposed therein.

19. A service tool for connecting to a valve seat and removing/inserting a valve core from/into the valve seat, comprising:

a generally hollow body having an open end, a closed end, and a port positioned between the open and closed ends;

a connector connected to said body adjacent the open end thereof to connect said body to the valve seat; and

a removal/insertion mechanism disposed within said body, said removal/insertion mechanism being movable within said hollow body along a longitudinal axis of said body between a first position adjacent the open end and a second position adjacent the closed end or said body, said removal/insertion mechanism including a split collet assembly for gripping the valve core.

20. A service tool according to claim 19, wherein said open end of said body has a hex.

21. A service tool according to claim 20, wherein said removal/insertion mechanism further includes a drive hex.

22. A service tool for connecting to a valve seat and removing/inserting a valve core from/into the valve seat, comprising:

a generally hollow body having an open end, a closed end, and a port positioned between the open and closed ends, said open end of said body having a hex;

a connector connected to said body adjacent the open end thereof to connect said body to the valve seat; and

a removal/insertion mechanism disposed within said body, said removal/insertion mechanism being movable within said hollow body along a longitudinal axis of said body between a first position adjacent the open end and a second position adjacent the closed end of said body, and said removal/insertion mechanism further includes a drive hex.

23. A method of performing processing operations on a closed loop fluid system, comprising:

attaching a service connection valve to the closed loop fluid system, the service connection valve including a valve seat fixed to the closed loop fluid system and a valve core that is removably connected to said valve seat, and said valve seat includes an exterior surface portion that is adapted to permit connection with a latching connector;

latching a service tool to said valve seat using a latching connector, said service tool including a removal/insertion mechanism that is capable of engaging said valve core so as to permit removal of said valve core from, or insertion of said valve core into, said valve [seat] seat, *a valve that is mounted for movement between a first position where flow through said tool is prevented and a second position where flow through said tool is permitted;*

removing said valve core from said valve seat using said removal/insertion mechanism of said service tool,

15

wherein removing said valve core occurs when said valve is in the first position; and

performing a processing operation on the closed loop fluid system through said valve seat, *and the processing operation is performed when said valve is in the second position.*

[24. A method according to claim 23, wherein said service tool further includes a valve that is mounted for movement between a first position where flow through said tool is prevented and a second position where flow through said tool is permitted, and wherein removing said valve core occurs when said valve is in the first position and the processing operation is performed when said valve is in the second position.]

25. A method according to claim 23, further including inserting said valve core back into said valve seat using said service tool after charging or evacuating.

26. A coupling for conducting servicing operations through a valve seat, comprising:

a body having first and second open ends and a flow path extending through said body between the first and second ends;

a latching connector associated with the first open end of said body to latch said body to the valve seat; and

a valve core associated with the second open end of said body controlling flow through said second open end, said valve core includes a portion thereof that projects beyond the second open end, and the portion of said valve core that projects beyond the second open end includes an exterior surface with a detent groove and threads adjacent the detent groove.

27. A coupling according to claim 26, wherein said valve core is detachably connected to said body within the second open end thereof, and the portion of said valve core that projects beyond the second open end further includes a hex head on the exterior surface adjacent the detent groove.

28. A system for performing processing operations on a closed loop fluid system, comprising:

a service connection valve adapted to be connected to the closed loop fluid system, the service connection valve including a valve seat adapted to be fixed to the closed loop fluid system and a valve core that is adapted to be removably connectable to said valve seat, and said valve seat includes an exterior surface portion that is adapted to permit connection with a latching connector; [and]

the valve seat includes a hex head;

the valve core includes a valve body and a valve assembly within the valve body, the valve core is removably attached to the valve seat via first threads, and the valve core includes a hex head; and

a service tool that is connectable with said valve seat, said service tool including:

a) a latching connector that is engageable with said exterior surface portion for connecting said service

16

tool to said valve seat, said latching connector comprising a latching ball connector;

b) a removal/insertion mechanism that is capable of engaging said valve core so as to permit removal of said valve core from, or insertion of said valve core into, said valve seat; and

c) a port through which fluid flow can occur.

29. A system for performing processing operations on a closed loop fluid system, comprising:

a service connection valve adapted to be connected to the closed loop fluid system, the service connection valve including a valve seat adapted to be fixed to the closed loop fluid system and a valve core that is adapted to be removably connectable to said valve seat, and said valve seat includes an exterior surface portion that is adapted to permit connection with a latching connector; and

a service tool that is connectable with said valve seat, said service tool including:

a) a latching connector that is engageable with said exterior surface portion for connecting said service tool to said valve seat;

b) a removal/insertion mechanism that is capable of engaging said valve core so as to permit removal of said valve core from, or insertion of said valve core into, said valve seat, said removal/insertion mechanism includes a split collet assembly for gripping said valve core; and

c) a port through which fluid flow can occur.

30. A service tool for connecting to a valve seat and removing/inserting a valve core from/into the valve seat, comprising:

a generally hollow body having an open end, a closed end, and a port positioned between the open and closed ends;

a latching connector connected to said body adjacent the open end thereof to releasably connect said body to the valve seat; and

a removal/insertion mechanism disposed within said body, said removal/insertion mechanism being movable within said hollow body along a longitudinal axis of said body in between a first position adjacent the open end and a second position adjacent the closed end of said body, wherein said removal/insertion mechanism comprises a socket that is designed to hold and retain said valve core, and said socket includes a split collet assembly disposed therein.

31. A system according to claim 1, wherein the hex head of the valve core abuts against an end of the valve seat.

32. A system according to claim 1, wherein the valve core includes second threads, the hex head of the valve core is between the first threads and the second threads, and the valve core includes a channel between the hex head of the valve core and the second threads.

* * * * *