



(12) **United States Design Patent**
van Breugel et al.

(10) **Patent No.:** **US D826,584 S**
(45) **Date of Patent:** **** Aug. 28, 2018**

(54) **CHILD'S SEAT**

1/006; A47D 1/06; A47D 1/002; A47D 1/004

(71) Applicant: **Thule Sweden AB**, Hillerstorp (SE)

See application file for complete search history.

(72) Inventors: **Gert-Jan van Breugel**, Tuil (NL); **Jort Nijhuis**, Amsterdam (NL); **Albert Nieuwenhuis**, Geldermalsen (NL); **Joline Karelse**, Utrecht (NL)

(56) **References Cited**

U.S. PATENT DOCUMENTS

| | | | |
|--------------|---------|----------------|--------------|
| D336,785 S | 6/1993 | Matsuda | |
| D613,955 S | 4/2010 | Kho et al. | |
| D688,474 S | 8/2013 | Tu | |
| D727,640 S | 4/2015 | Carell | |
| D727,641 S | 4/2015 | Eriksson | |
| D796,854 S | 9/2017 | Larsson et al. | |
| D799,220 S * | 10/2017 | van Breugel | D6/333 |

(73) Assignee: **Thule Sweden AB**, Hillerstorp (SE)

(**) Term: **15 Years**

OTHER PUBLICATIONS

(21) Appl. No.: **29/616,652**

Yepp.com, "Mini", <<http://web.archive.org/web/20150813030705/http://www.yepp.nl/en/product/mini/>>, dated Jul. 3, 2015.
Yepp.com, "Maxi", <<http://web.archive.org/web/20151127121935/http://www.yepp.nl/en/product/maxi/>>, dated Jul. 3, 2015.

(22) Filed: **Sep. 7, 2017**

Related U.S. Application Data

* cited by examiner

(63) Continuation of application No. 29/572,383, filed on Jul. 27, 2016.

Primary Examiner — Abraham Bahta
(74) *Attorney, Agent, or Firm* — Sterne, Kessler, Goldstein & Fox P.L.L.C.

(51) **LOC (11) Cl.** **06-01**

(52) **U.S. Cl.**
USPC **D6/333**

(57) **CLAIM**

(58) **Field of Classification Search**
USPC D6/333–336, 339, 344, 702, 716, D6/716.1–716.7; 297/183.1–183.4, 297/184.13, 184.15, 184.17, 250.1, 255, 297/256.1, 256.15, 219.12, 463.1; D12/129–130, 133; D21/412, 428, 419; 280/30–31; 5/94, 98.1, 99.1, 101–102, 5/105, 655, 93.1, 12.1; 24/200
CPC . B60N 2/00; B60N 2/005; B60N 2/24; B60N 2/015; B60N 2/42; B60N 2/26; A47C 13/00; A47C 4/54; A47C 4/00; A47C 4/02; A47C 3/029; A47C 3/025; A47C 3/021; A47C 3/0252; A47D 1/00; A47D

The ornamental design for a child's seat, as shown and described.

DESCRIPTION

FIG. 1 is a top front perspective view of a child's seat showing the claimed design;
FIG. 2 is a bottom rear perspective view thereof;
FIG. 3 is a front view thereof;
FIG. 4 is a rear view thereof;
FIG. 5 is a left side view thereof;
FIG. 6 is a right side view thereof;
FIG. 7 is a top view thereof; and,
FIG. 8 is a bottom view thereof.

(Continued)

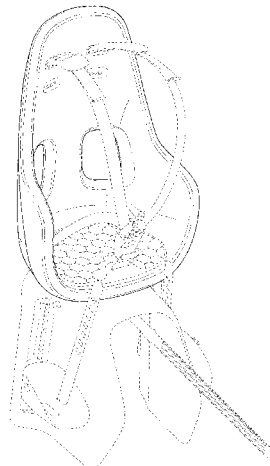

The broken lines in the figures show portions of the child's seat that form no part of the claimed design.

1 Claim, 8 Drawing Sheets

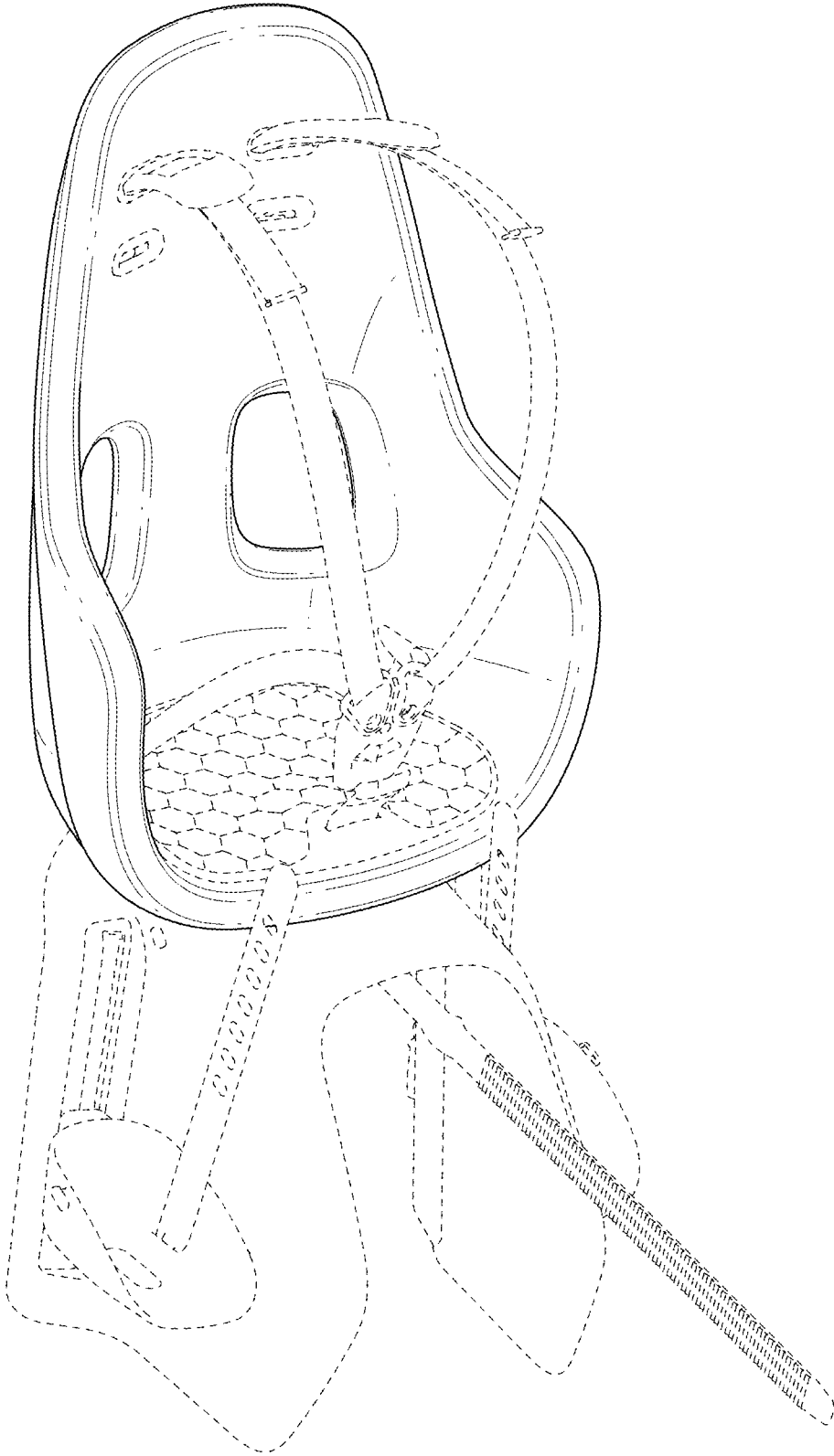

FIG. 1

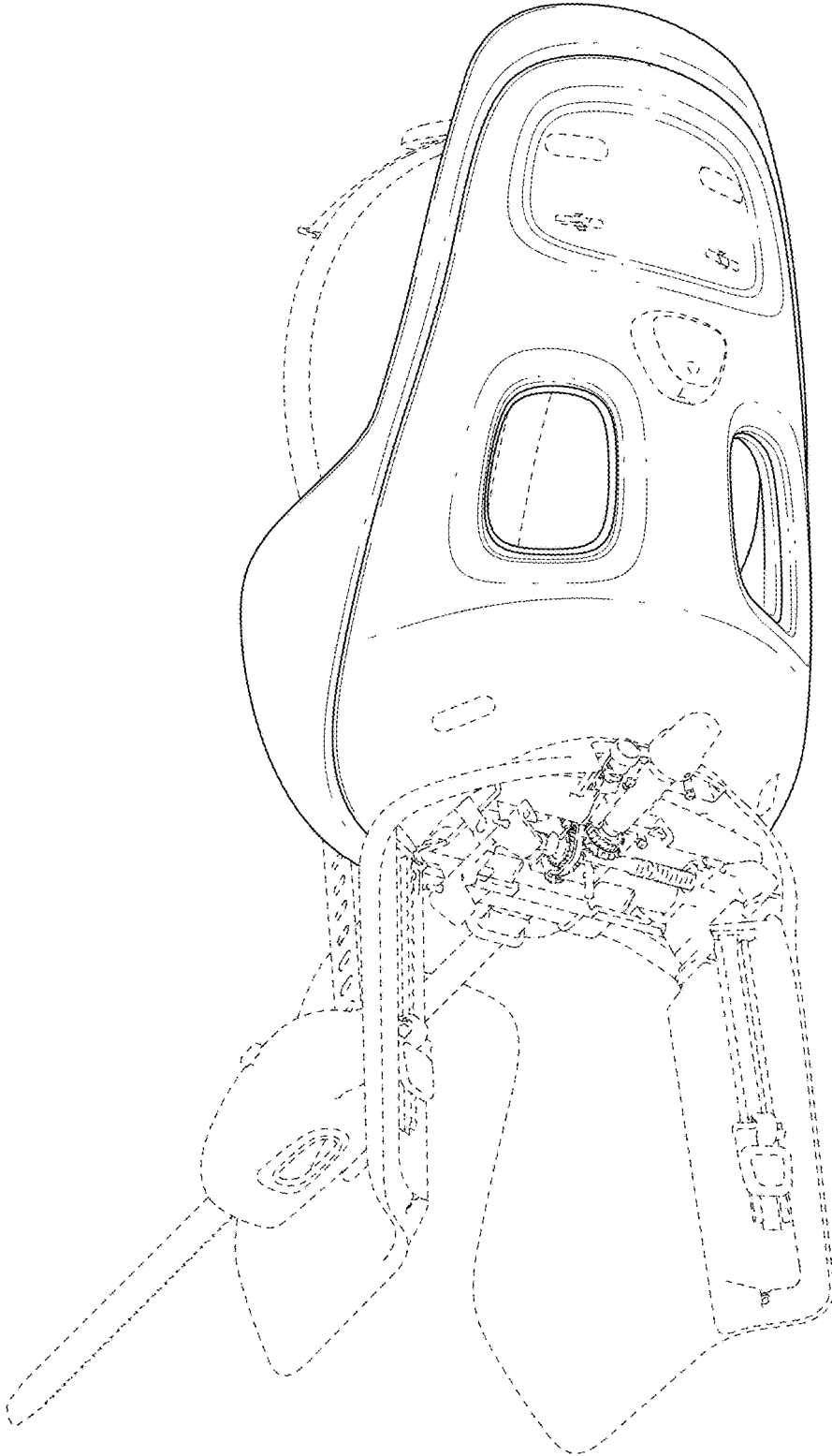

FIG. 2

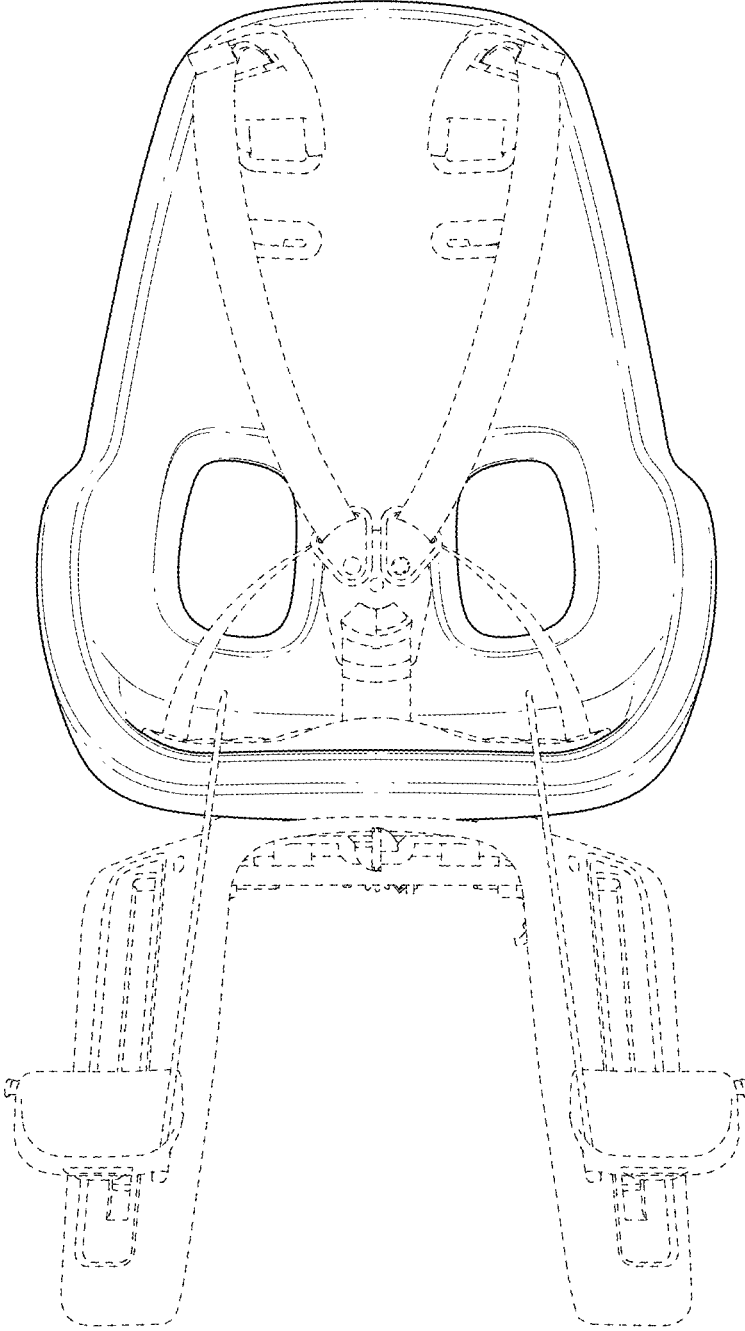

FIG. 3

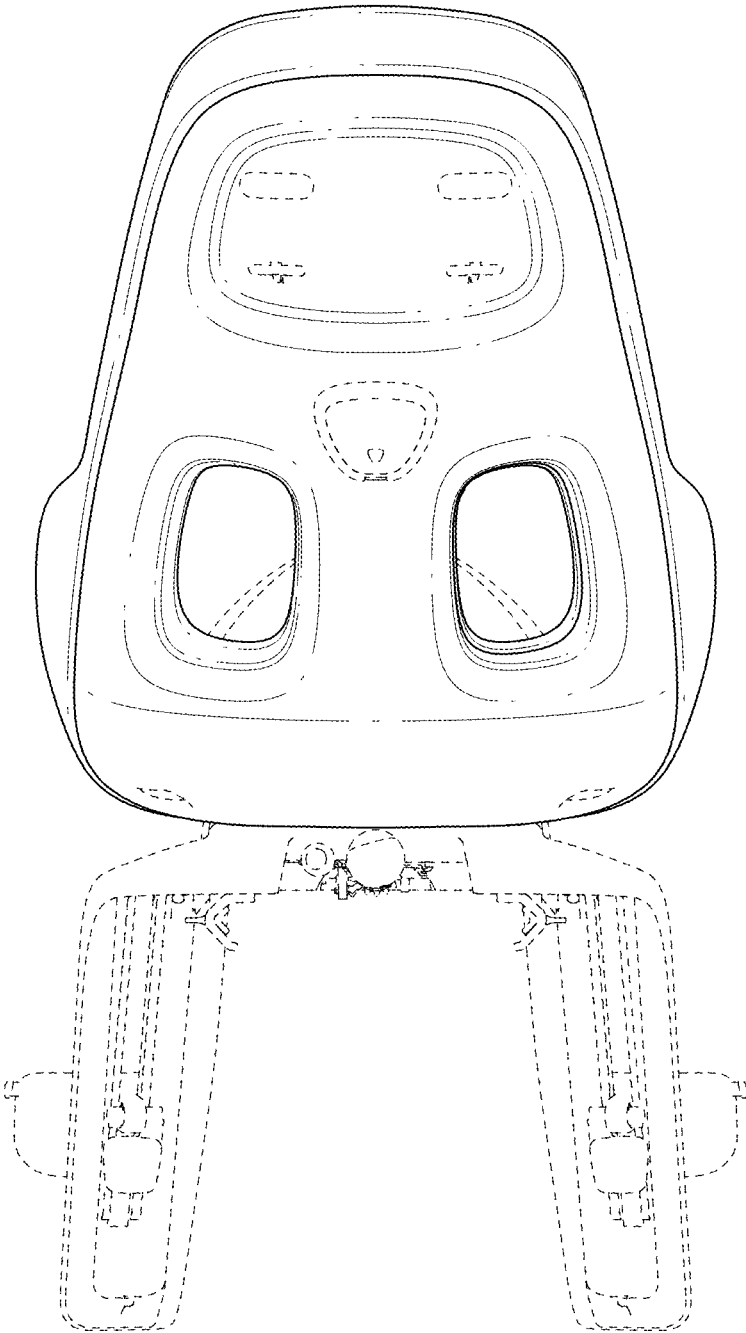

FIG. 4

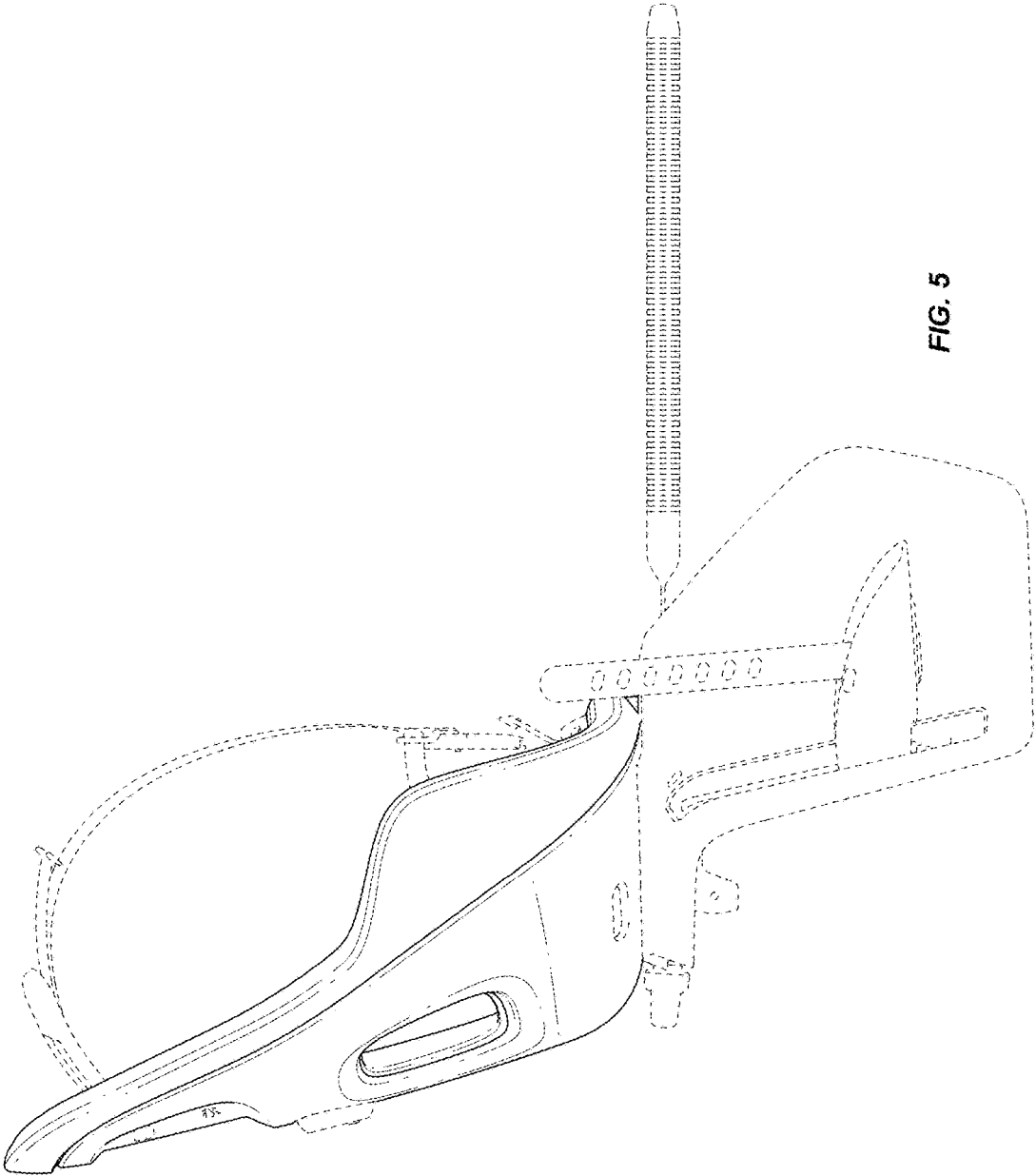

FIG. 5

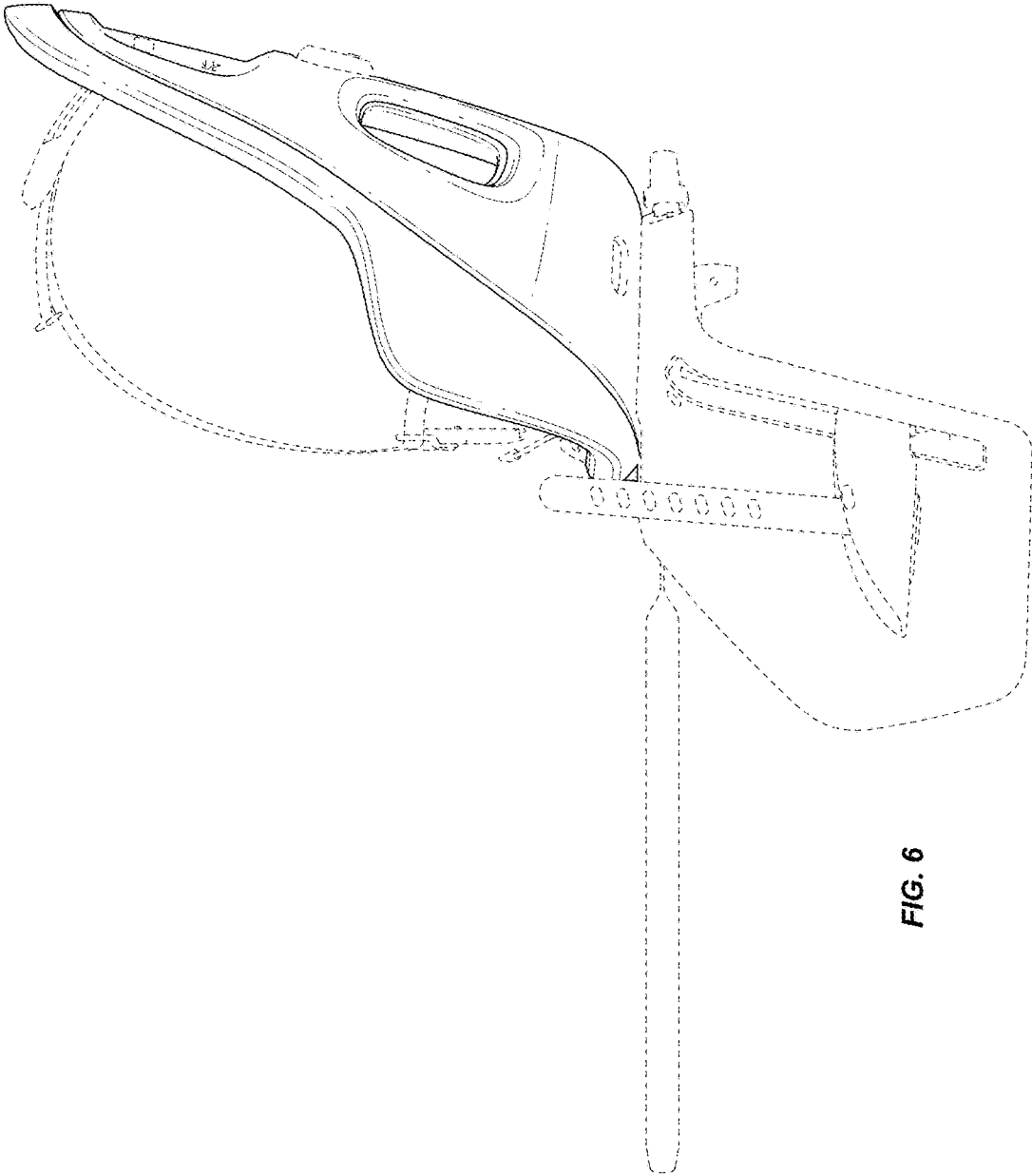

FIG. 6

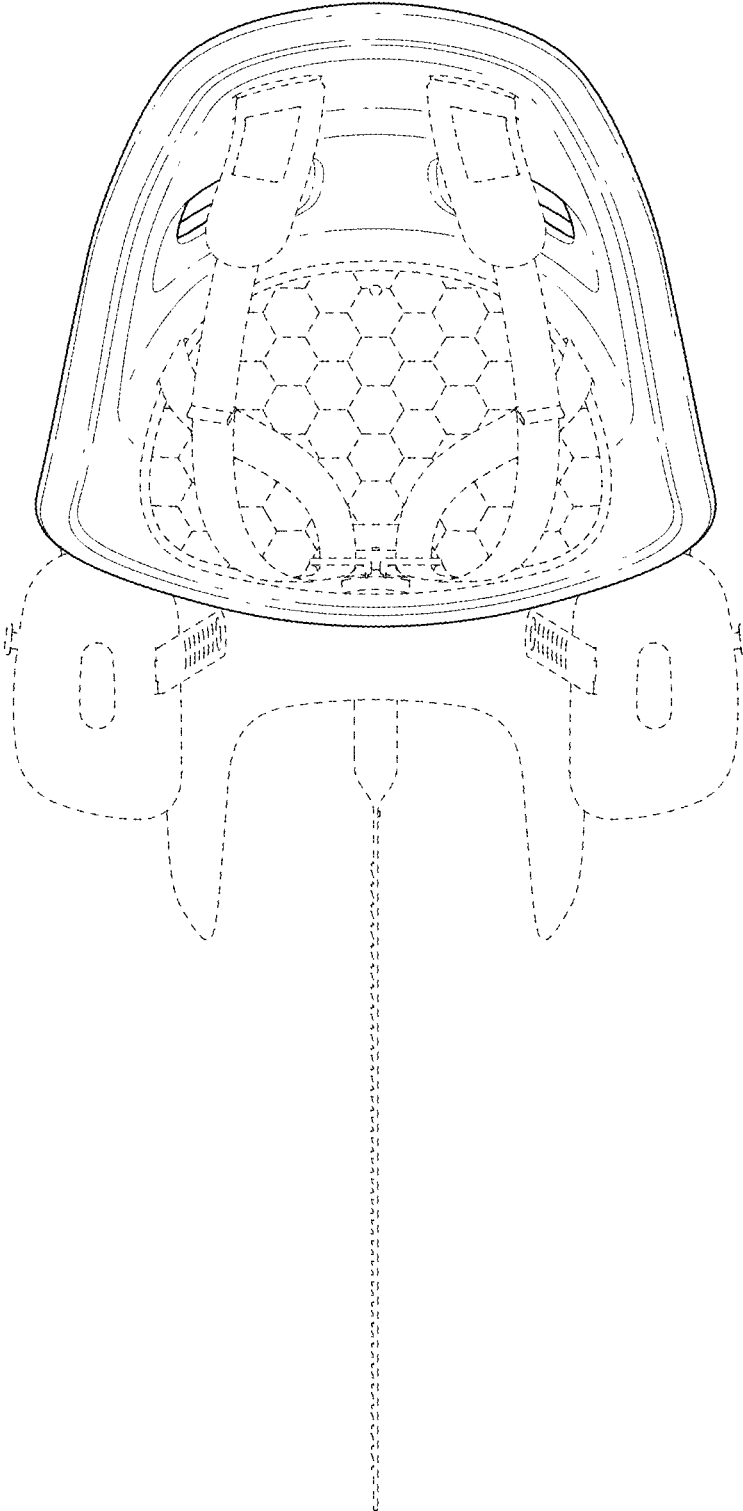

FIG. 7

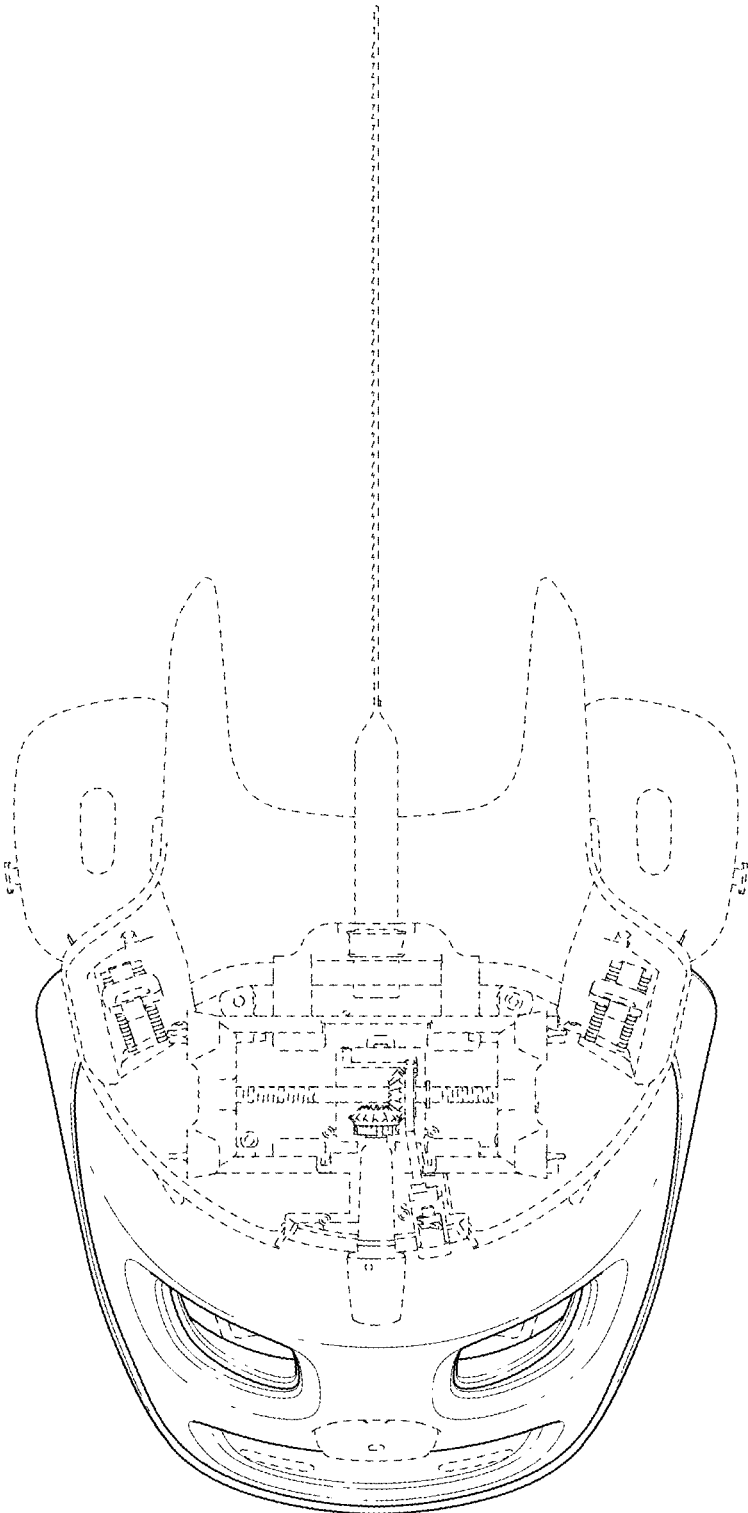

FIG. 8