

(No Model.)

2 Sheets—Sheet 1.

O. H. DECUMBUS.

PROJECTILE RECEIVER FOR TARGETS.

No. 385,546.

Patented July 3, 1888.

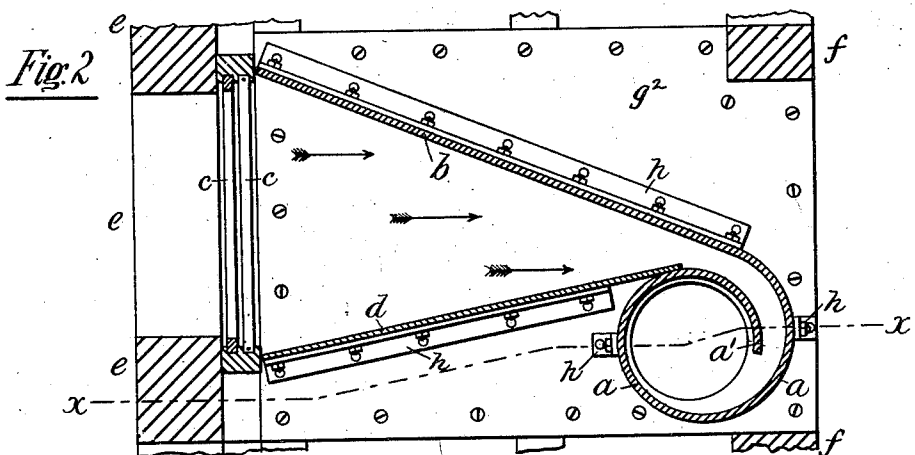
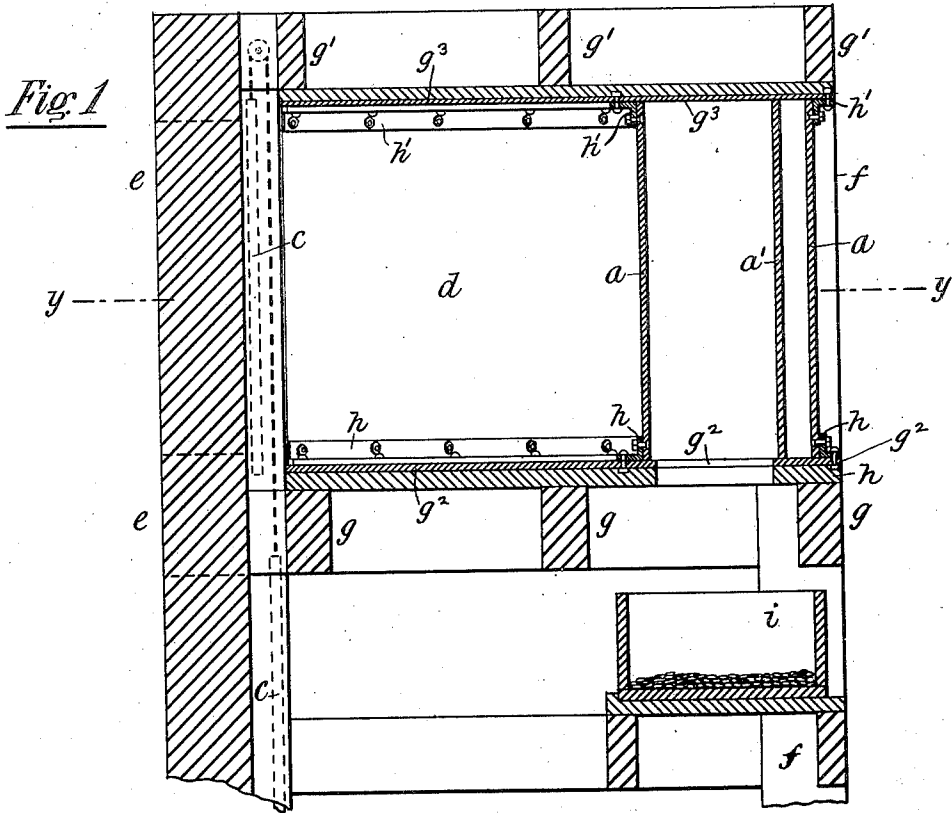

Witnesses.

Henry D. Williams.
Edwin Seger

O. H. Decumbus.
Inventor
By his attorney W. H. Kenyon.

O. H. DECUMBUS.

PROJECTILE RECEIVER FOR TARGETS.

No. 385,546.

Patented July 3, 1888.

Fig. 3

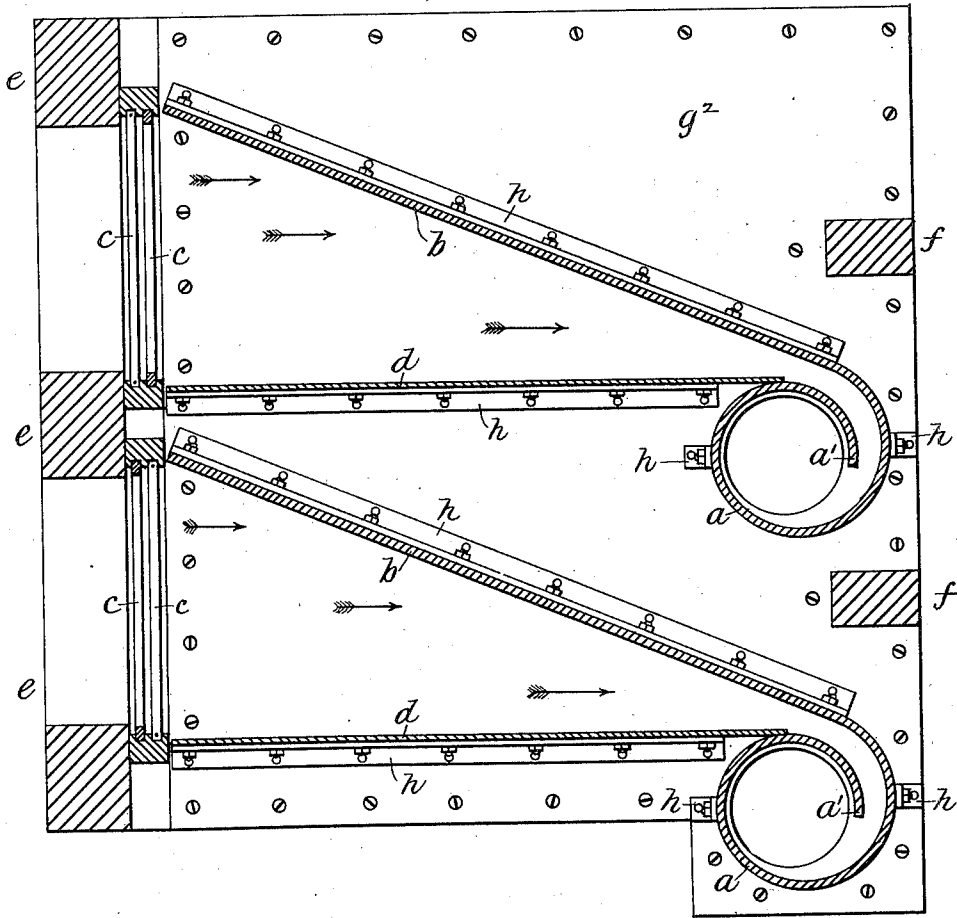

Witnesses

Henry D. Williams.
Edwin Seger

Oliver H. Decumbus.

Inventor.

By his attorney W. H. Kenyon.

UNITED STATES PATENT OFFICE.

OLIVER H. DECUMBUS, OF NEWARK, NEW JERSEY.

PROJECTILE-RECEIVER FOR TARGETS.

SPECIFICATION forming part of Letters Patent No. 385,546, dated July 3, 1888.

Application filed May 2, 1888. Serial No. 272,581. (No model.)

To all whom it may concern:

Be it known that I, OLIVER H. DECUMBUS, a citizen of the United States, residing at Newark, Essex county, State of New Jersey, have invented certain new and useful Improvements in Projectile-Receivers, of which the following is a specification, reference being had to the accompanying drawings, which form a part hereof.

The object of this invention is to provide a means for receiving bullets or other projectiles traveling at a high velocity; and it is especially adapted to be used in rifle-ranges to receive and retain the projectiles that have passed through the targets.

The invention comprises certain mechanical devices whereby the projectiles are deflected and guided until their energy of motion has been expended and they drop into suitable receptacles; and these devices consist, essentially, of a chamber the cross-section of which is a circle, ellipse, or other closed curve, and a plate projecting from the wall of said chamber and inclined at an acute angle to the path of the projectiles, a sufficient opening being made in the wall of the chamber to form a passage for the entrance of the projectiles. The plate is placed in such position in relation to the target that projectiles which have passed through the target strike the plate and are thereby deflected and slide along its surface and into the chamber, and continue to circulate around the chamber until their energy of motion is expended, when they drop into a receptacle suitably placed. I in some cases prefer to use a second deflecting-plate, also adapted to deflect and guide the projectiles into the receiving-chamber; but to describe my invention more particularly I will now refer to the accompanying drawings, in which—

Figure 1 is a sectional elevation, taken on the line $x x$, Fig. 2, showing my projectile-receiver placed behind a target. Fig. 2 is a horizontal section of the same on the line $y y$, Fig. 1; and Fig. 3 is a similar view showing two projectile-receivers of a modified construction.

The receiving-chamber, as shown in the drawings, is of approximately circular cross-section and rectangular vertical section, and the wall a of this chamber is made in one

piece with the deflecting-plate b , as clearly shown in Fig. 2. The deflecting-plate b projects tangentially from the wall a of the receiving-chamber, so that this wall and the plate form one continuous unbroken surface. An opening is made in the wall a at the point where the plate projects therefrom, and the wall is continued beyond this opening, forming an inner extension or tongue, a' , parallel to the outer wall, the function of which will be hereinafter described. The deflecting-plate b is vertically arranged and its position in relation to the targets $c c$ is such that projectiles which have passed through the targets strike the deflecting-plate at a very acute angle, as shown in Fig. 2, the arrows representing the direction of motion of such projectiles.

A second deflecting-plate, d , is shown in the main views of the drawings. The rear edge of this plate d rests against the wall a of the receiving-chamber, and the plate is so placed as to receive on its surface all projectiles passing through the targets that do not strike the deflecting-plate b . This deflecting-plate d is shown arranged at a more acute angle to the path of the projectiles than the plate b , and can therefore be made of thinner material.

In the modification shown in Fig. 3 the second plate, d , has no function to perform in deflecting the projectiles, all of which are received upon and deflected by the plate b ; and it will be evident from comparison of these drawings that the use of a second or auxiliary deflecting-plate effects a considerable saving in the general dimensions of the device.

The wall a , deflecting-plates b d , and other plates used in the apparatus are made of sheet steel, iron, or other suitable material.

The deflecting-plates and walls of the receiving-chamber are held in position by a frame-work of timbers. This supporting-frame will be varied to suit requirements and conditions. As shown in the drawings, this frame comprises the guarding-timbers $e e$, the rear supporting-timbers, $f f$, the floor-beams $g g$, and the roof-beams $g' g'$. The guarding-timbers $e e$ are so placed as to protect the frames of the targets, and are generally combined with other timbers (not shown) adapted to receive all projectiles that do not strike the targets, and between the guarding-timbers $e e$ a rectangular opening is formed which exposes

the targets. These targets *c c* are generally made of cloth or paper stretched upon rectangular frames and fitted to slide up and down in ways. Sash-cords running over pulleys connect the targets together, so that when one is pulled down the other rises in place. The lower ends of the timbers *e* and *f* and part of one of the targets are shown broken away in Fig. 1; but it is obvious that they can rest upon any flooring or foundation, sufficient height being allowed for working the targets. The construction and operation of the targets are such as commonly used, and therefore need not be carefully described or shown.

The deflecting-plates and wall of the receiving-chamber may be secured to this framing in any desired manner; but I prefer to provide a flooring and roof composed of or faced with metal plates, and to secure the deflecting-plates and wall of the chamber to these plates by angle-iron connections. A suitable wooden flooring is laid upon the floor-beams *g g*, and an iron plate or plates, *g' g'*, secured thereon. Angle-irons *h h* are bolted to this floor and to the lower ends of the plates *b* and *d* and wall *a* of the receiving-chamber. A wooden roofing is secured to the beams *g' g'*, and an iron facing, *g'' g''*, secured thereto, and the angle-irons *h' h'* connect this roofing with the deflecting-plates and wall of the receiving-chamber. An opening is cut in the flooring, so as to remove the bottom of the chamber, and a box or other suitable receptacle, *i*, is placed beneath this opening, so as to receive everything that falls therethrough. This box *i* rests upon a flooring and can be removed and replaced at pleasure. It will thus be observed that a wedge-shaped chamber lined with metal plates is formed, including the guarding-timbers *e*, and that all projectiles which have passed through the targets will impinge upon one of the deflecting-plates *b* or *d*. As the projectiles are composed of lead or similar soft and non-elastic material, the concussion with the deflecting-plate may slightly flatten them. There is little or no rebound, and as they strike at a very acute angle they are caused to slide along the surface of the plate. If they strike the plate *d*, they are caused to follow its surface to the rear end, and then, passing from the same in a straight line, impinge upon the plate *b*. Their subsequent course is similar to that of projectiles which have primarily impinged upon the plate *b*—that is, they are guided along, following the curvature of the same, and enter the receiving-chamber. They follow the wall *a* of the chamber until the end of the tongue *a'* is reached, and then, leaving the same on a tangential line, impinge again upon the wall *a*, follow its curvature, and repeat the previous movement, and this continues until the energy of motion of the projectiles is destroyed, and they fall through the opening in the floor into the receptacle *i*.

In Fig. 3 I have shown a modification in the

construction of my projectile-receiver. In this view the plate *d* is about parallel to the path of the projectiles, so that none of the projectiles impinge thereon. As before remarked, this construction necessitates increase in the dimensions of the apparatus when a similar angle of deflection is used as compared with that shown in the main views of the drawings. It will be seen that in this construction the second plate, *d*, is not a deflecting-plate and has no other function to perform than that of the metal-faced roof and floor—viz., to prevent all possibility of escape of the projectiles or particles of the same; and in Fig. 3 I have shown two sets of targets and receivers placed side by side, from which it will be seen that the targets can be placed in close proximity to each other—a great desideratum in rifle-ranges.

It is evident that the projectiles are received, controlled, and finally deposited into a suitable receptacle without subjecting any part of the device to severe concussions or blows. When a projectile strikes a deflecting-plate, it is moving at a high velocity; but the plate is inclined at such a sharp or acute angle to the direction of motion of the projectile that comparatively little resisting force is necessary to deflect the projectile, so that it will move on in contact with the surface of the plate, and as the projectile enters the receiving-chamber and circulates in contact with the wall *a* a slight centripetal pressure acts upon it, which gradually retards its motion. The utility of the tongue *a'* will now be apparent, as it serves to guide the projectile, so that after leaping across the opening it impinges upon the wall *a* at a more acute angle, and as the impelling force of the projectile is gradually destroyed the force of gravity pulls it downward, and it finally falls into the receptacle *c* somewhat flattened, but in condition to be remolded and again used, and this freedom from heavy strains permits the use of comparatively thin plates and light and inexpensive construction.

Various devices are at present used aiming to accomplish the object of this invention, but in all the projectile is checked by violent concussion, which causes partial or entire disintegration and liquefaction of the projectile. The spattering of fine particles often causes injury to the attendants manipulating the targets and signaling the score, and involves considerable waste of lead or other material of which the projectile is composed, whereas in my device every projectile that penetrates the targets is caught and retained without danger to the attendants or waste of material.

Having now described my invention, what I claim, and desire to secure by Letters Patent, is—

1. A projectile-receiving device consisting of a chamber the cross section of which is a closed curve and the wall of which is provided with a longitudinal opening, and a deflecting-plate extending from the wall at the opening therein and inclined at an acute angle to the

path of the projectiles, substantially as shown and described.

2. A projectile-receiving device consisting of a chamber the cross-section of which is a closed curve and the wall of which is provided with a longitudinal opening, an extension from the wall of the chamber overlapping said opening, and a deflecting-plate extending from the wall at the opening therein and inclined at an acute angle to the path of the projectiles, substantially as shown and described.

3. A projectile-receiving device consisting of a chamber the cross-section of which is a closed curve and the wall of which is provided with a longitudinal opening, a deflecting-plate extending from the wall at one side of the opening therein and inclined at an acute angle to the path of the projectiles, and a second deflecting-plate extending from the other side of the opening in the wall and also inclined at an acute angle to the path of the projectiles, substantially as shown and described.

4. A projectile-receiving device consisting of a chamber the cross-section of which is a closed curve and the wall of which is provided with a longitudinal opening, an extension from the wall of the chamber overlapping said opening, a deflecting-plate extending from the wall at one side of the opening therein and inclined at an acute angle to the path of the projectiles, and a second deflecting-plate extending from the other side of the opening in the

wall and also inclined at an acute angle to the path of the projectiles, substantially as shown and described.

5. A projectile-receiving device consisting of a chamber rectangular in vertical section and a closed curve in cross-section vertically arranged and provided with a longitudinal opening in its wall, a deflecting-plate also vertically arranged extending from the wall at the opening therein and inclined at an acute angle to the path of the projectiles, and an opening in the bottom of the chamber for the discharge of the projectiles, substantially as shown and described.

6. The combination, with guarding devices having a rectangular opening therein and a target exposed by said opening, of the projectile-receiving device consisting of a chamber the cross-section of which is a closed curve and the wall of which is provided with a longitudinal opening, and a deflecting-plate extending from the wall at the opening therein, inclined at an acute angle to the path of the projectiles, and placed so as to receive upon its surface all projectiles that have passed through the target, substantially as shown and described.

OLIVER H. DECUMBUS.

Witnesses:

HENRY D. WILLIAMS,
ARTHUR VAN SICLEN.