

(12) **UK Patent Application** (19) **GB** (11) **2 300 549** (13) **A**

(43) Date of A Publication 06.11.1996

(21) Application No **9608913.1**
(22) Date of Filing **30.04.1996**
(30) Priority Data
(31) **9508901** (32) **02.05.1995** (33) **GB**

(71) Applicant(s)
Northern Telecom Limited

(Incorporated in Canada - Ontario)

**World Trade Center Of Montreal,
380 St Antoine Street West, 8th Floor, Montreal,
Quebec H2Y 3Y4, Canada**

(72) Inventor(s)
Paul Newson

(74) Agent and/or Address for Service
J P W Ryan
**Nortel limited, West Road, HARLOW, Essex,
CM20 2SH, United Kingdom**

(51) INT CL⁶
H04Q 7/30

(52) UK CL (Edition O)
**H4R RCC
U1S S2215**

(56) Documents Cited
EP 0526285 A2 WO 92/13400 A1

(58) Field of Search
UK CL (Edition O) **H4L LDA , H4R RCC**
INT CL⁶ **H04B 7/26 , H04H 1/02 , H04Q 7/30 7/38**
Online:WPI

(54) **Cellular comms using catv**

(57) A CATV distribution network provides an interface between a cellular communications base station and a plurality of mobile terminals. A head end signal processor disposed at a head end of the CATV network provides a first frequency conversion between a cellular communications radio frequency and the CATV network transmission frequency. A plurality of remote antenna drivers are disposed at the remote end of the CATV network and provide a second frequency conversion between the cellular communications radio frequency and the CATV network transmission frequency. Antennas coupled to the remote antenna drivers provide radio communications with the mobile terminals. The remote antenna drivers are arranged in groups, each group being operated in a simulcast manner. Dynamic range compression of the cellular communications traffic is provided on the upstream path between the mobile terminals and the base station.

Fig.1.

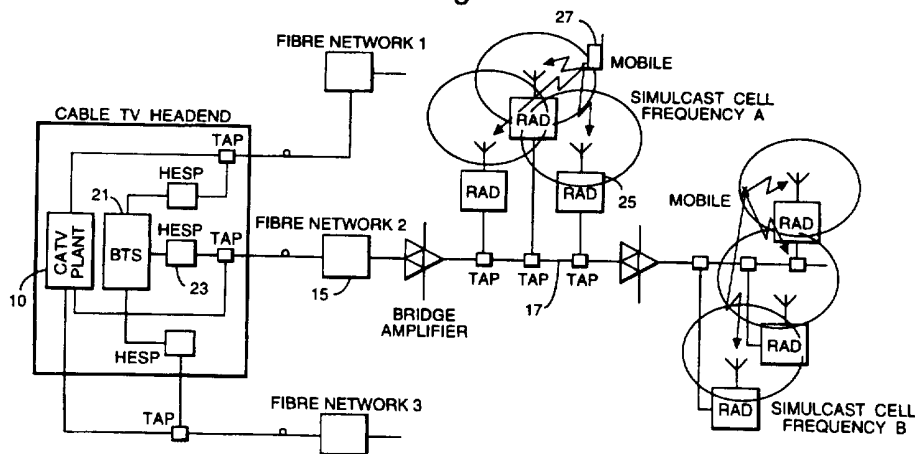

GB 2 300 549 A

Fig.1.

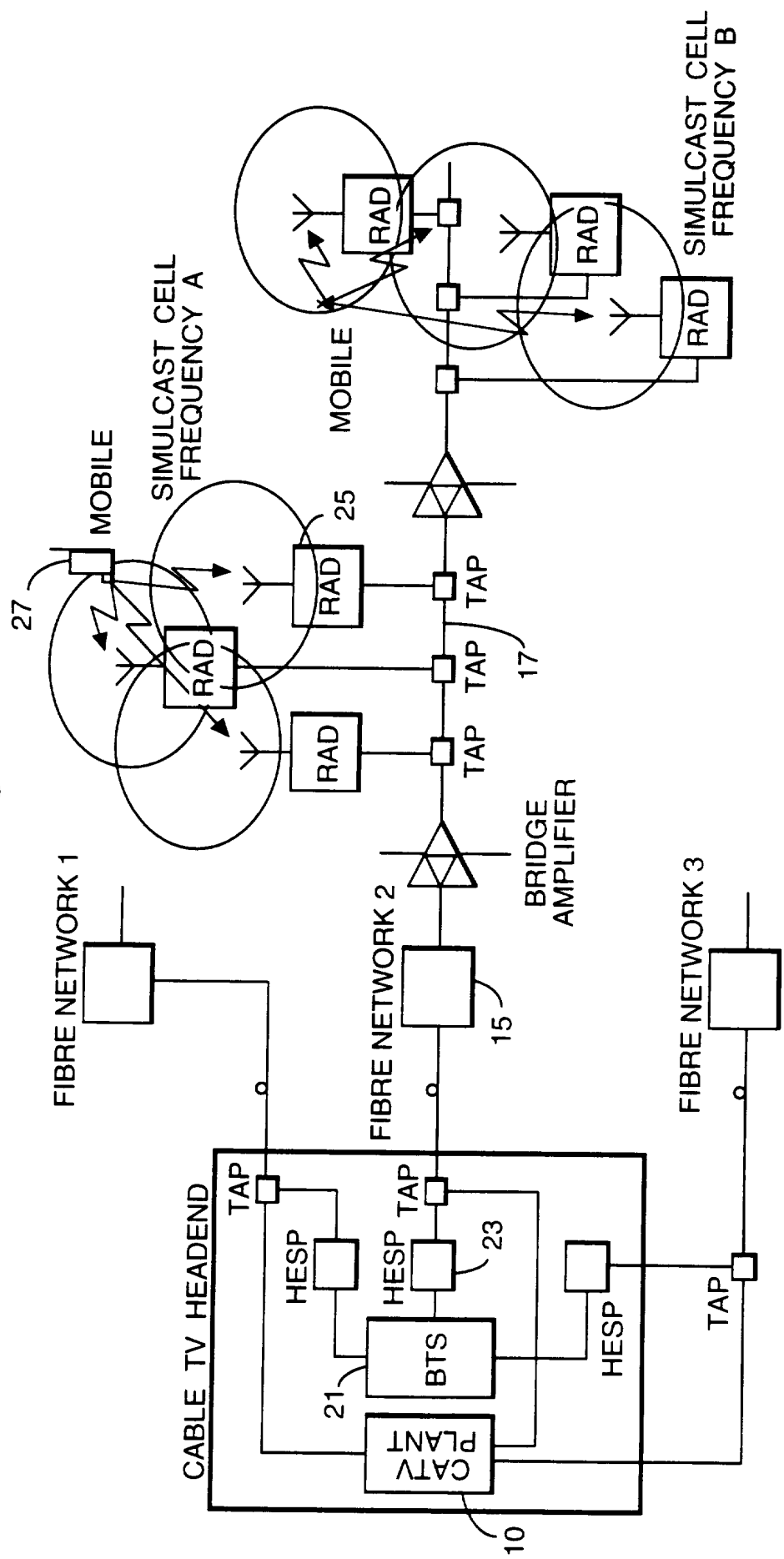

Fig.2.

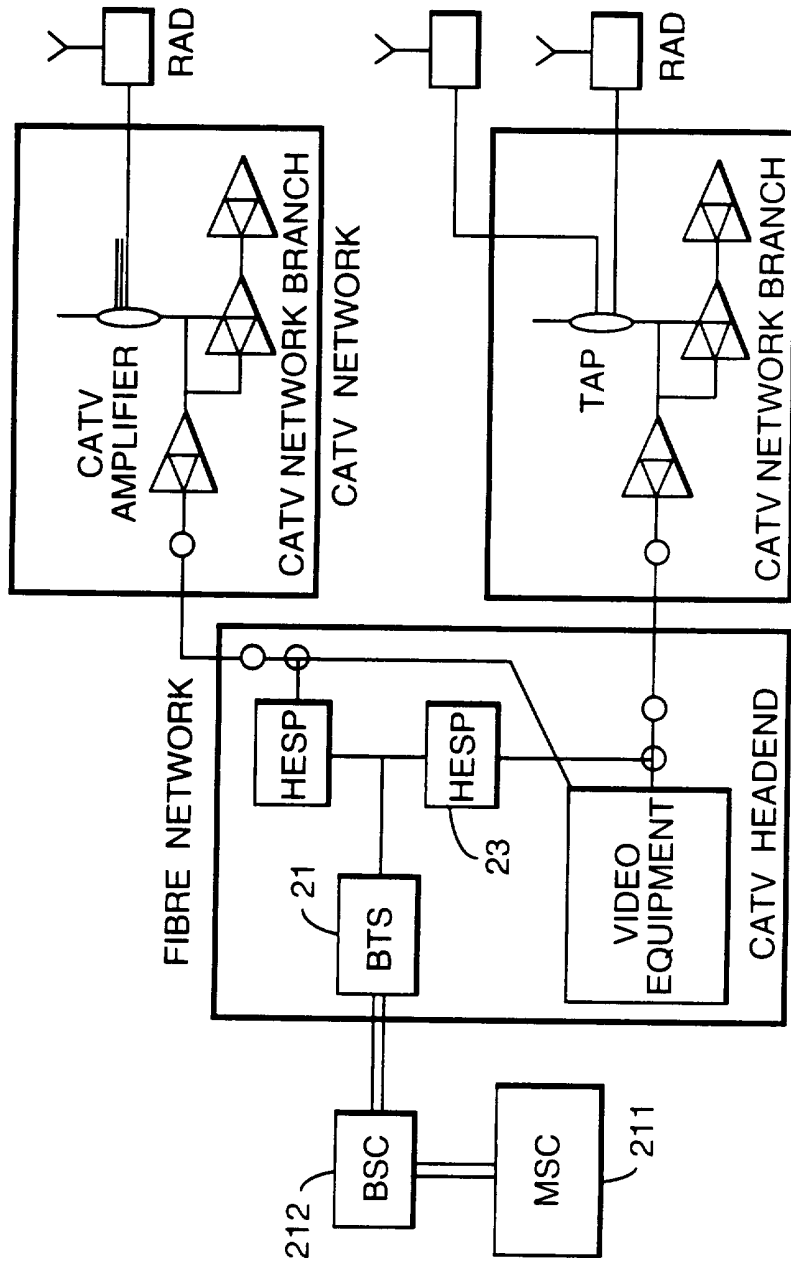

Fig.3a.

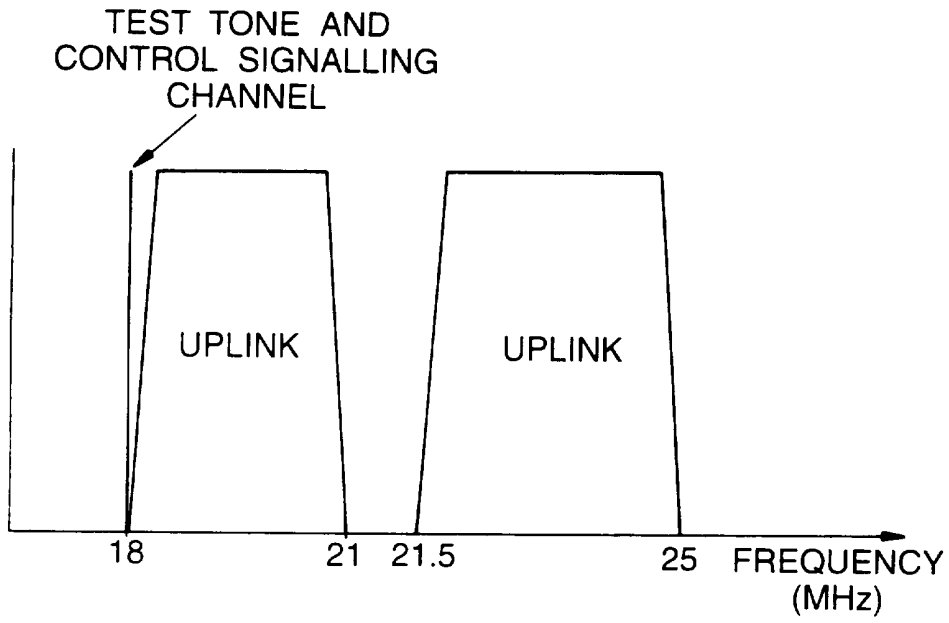
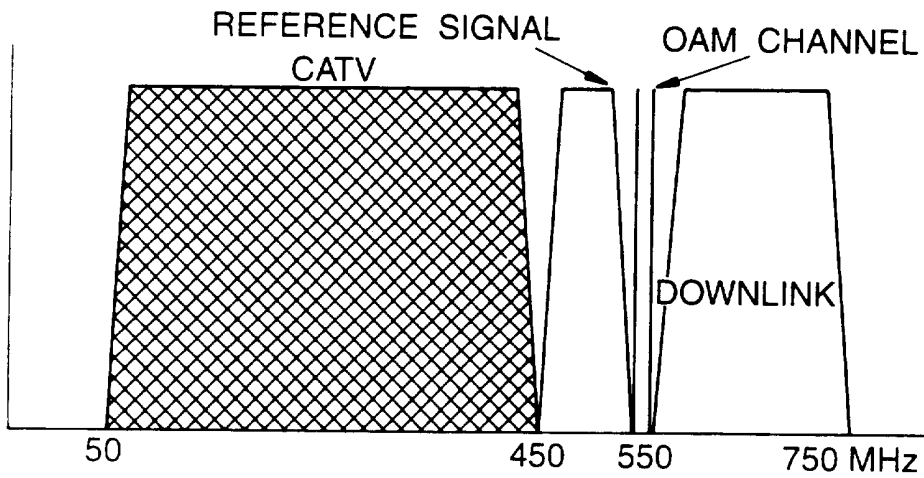

Fig.3b.



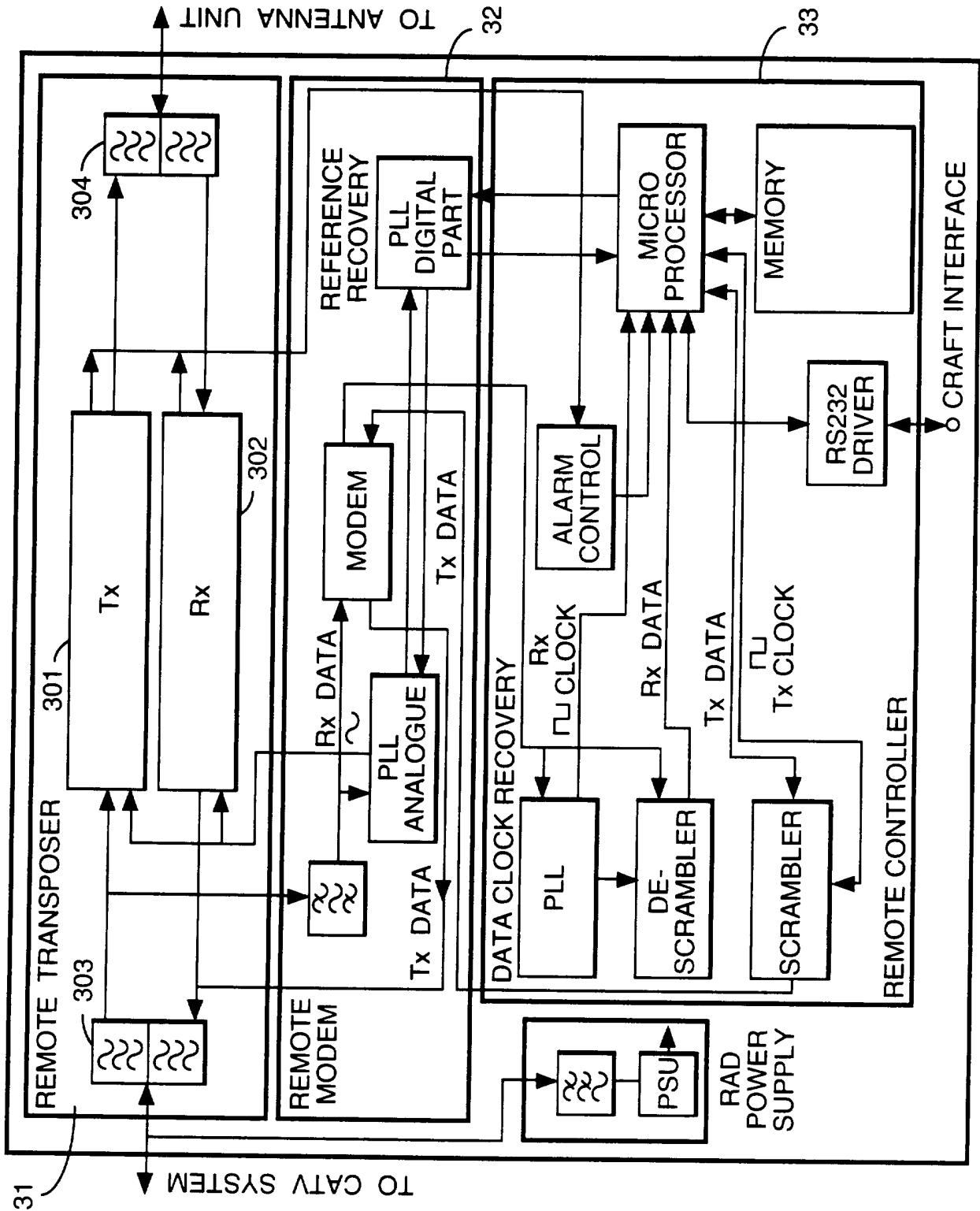

Fig. 4.

31

REMOTE TRANSPONDER

301

Tx

Rx

302

MODEM

REFERENCE RECOVERY

PLL ANALOGUE

PLL DIGITAL PART

DATA CLOCK RECOVERY

PLL

DE-SCRAMBLER

Rx CLOCK

Rx DATA

Tx DATA

Tx CLOCK

ALARM CONTROL

MICRO PROCESSOR

MEMORY

RS232 DRIVER

REMOTE CONTROLLER

CRAFT INTERFACE

303

Tx DATA

Rx DATA

Tx DATA

Tx DATA

Tx DATA

Rx CLOCK

Rx DATA

Tx DATA

Tx CLOCK

TO CATV SYSTEM

TO ANTENNA UNIT

32

33

Fig.5.

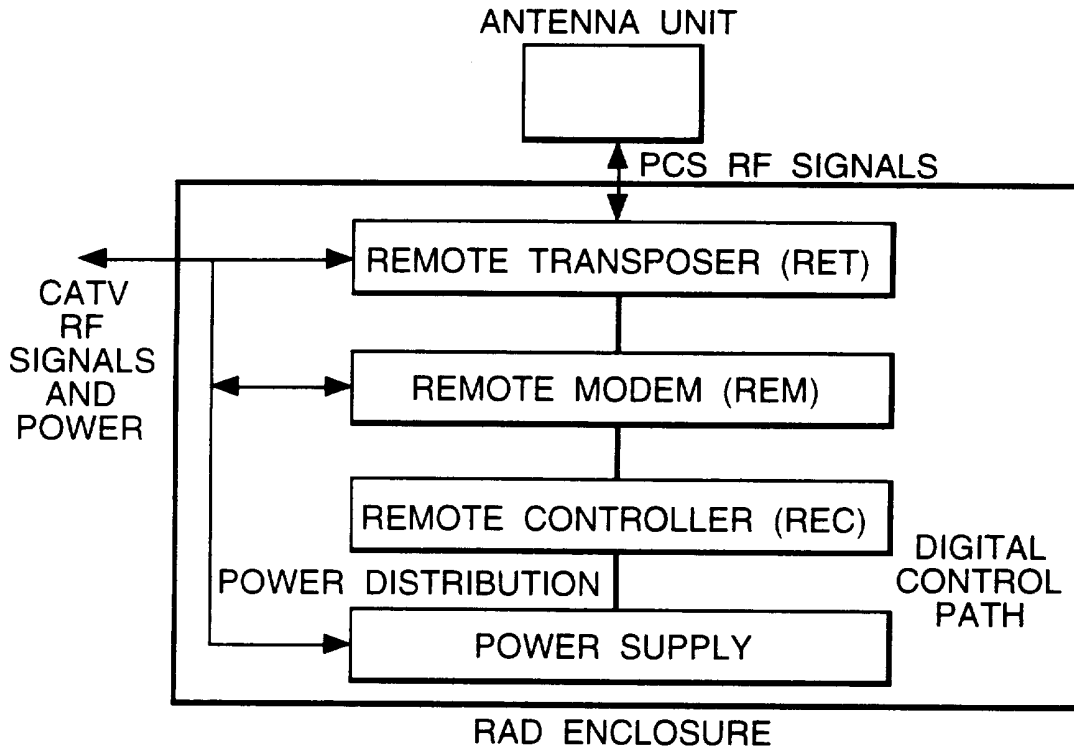

Fig.10.

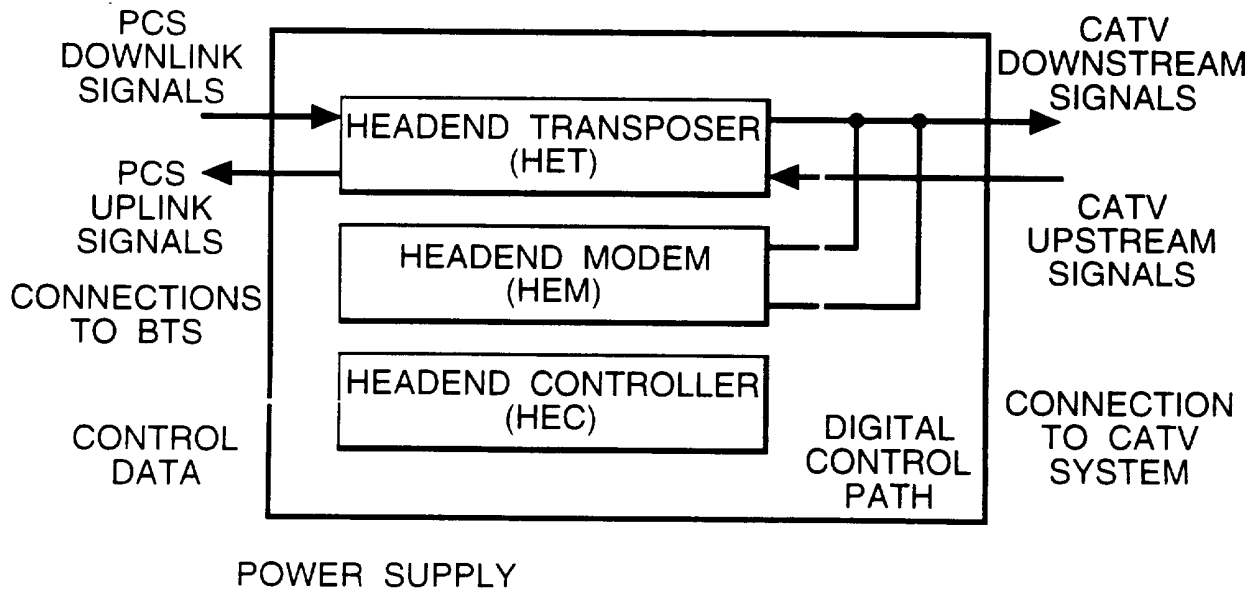

Fig.6.

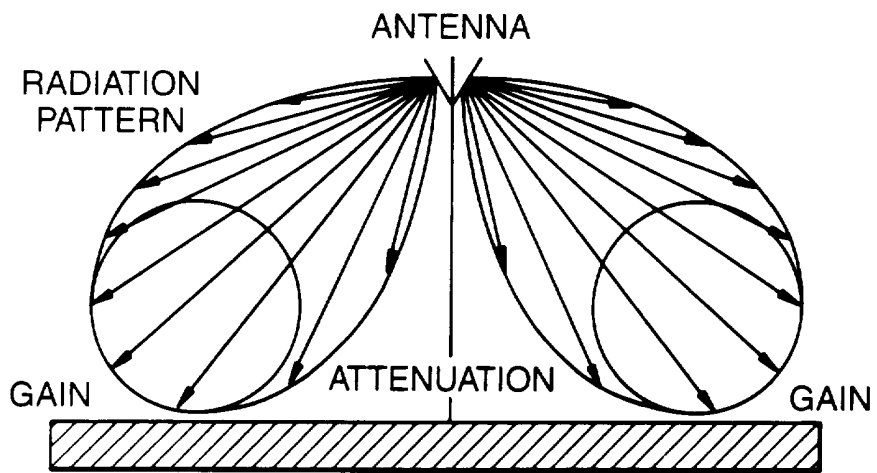

Fig.7.

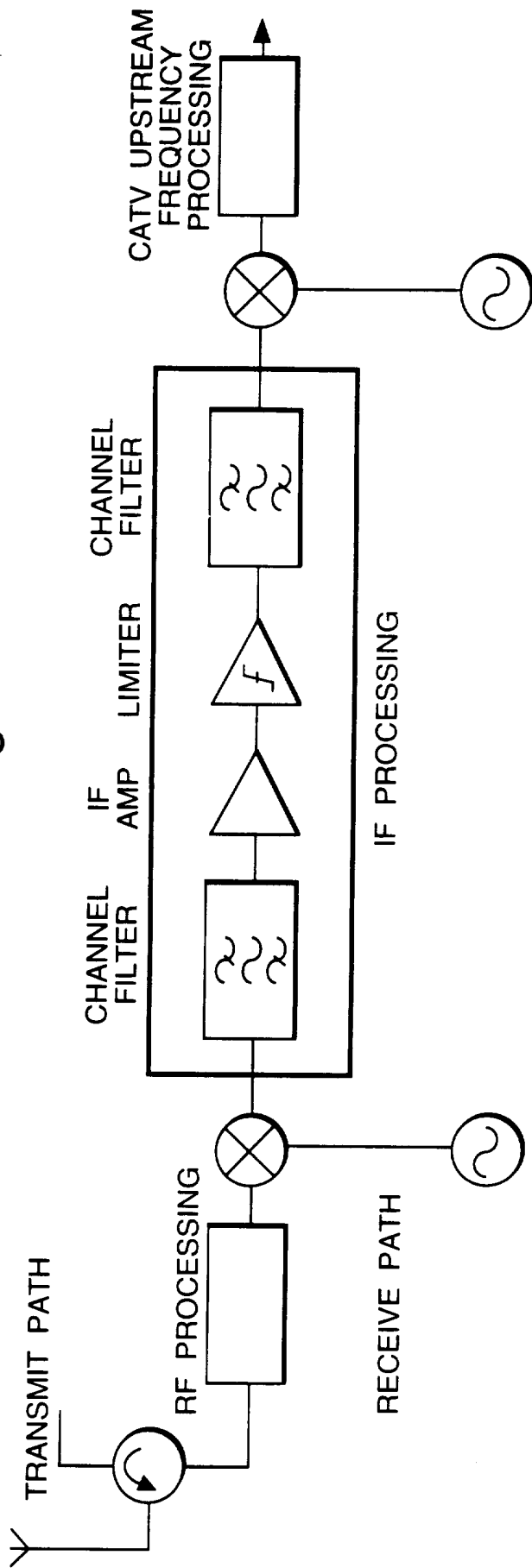

Fig.8.

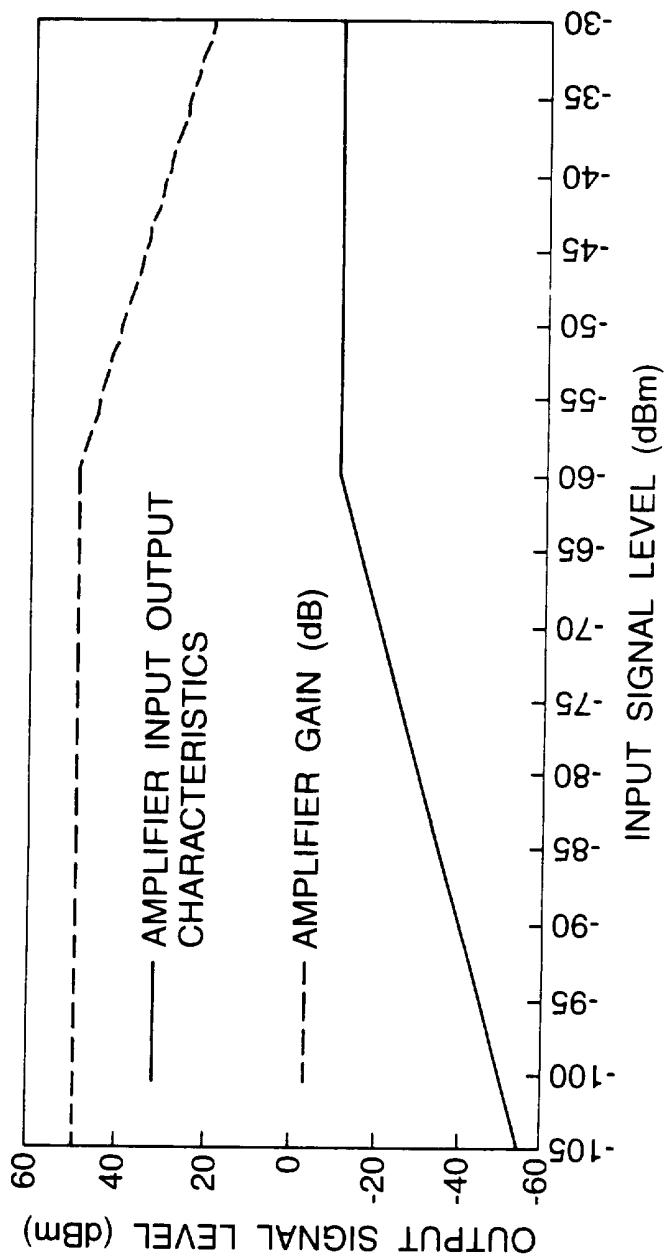
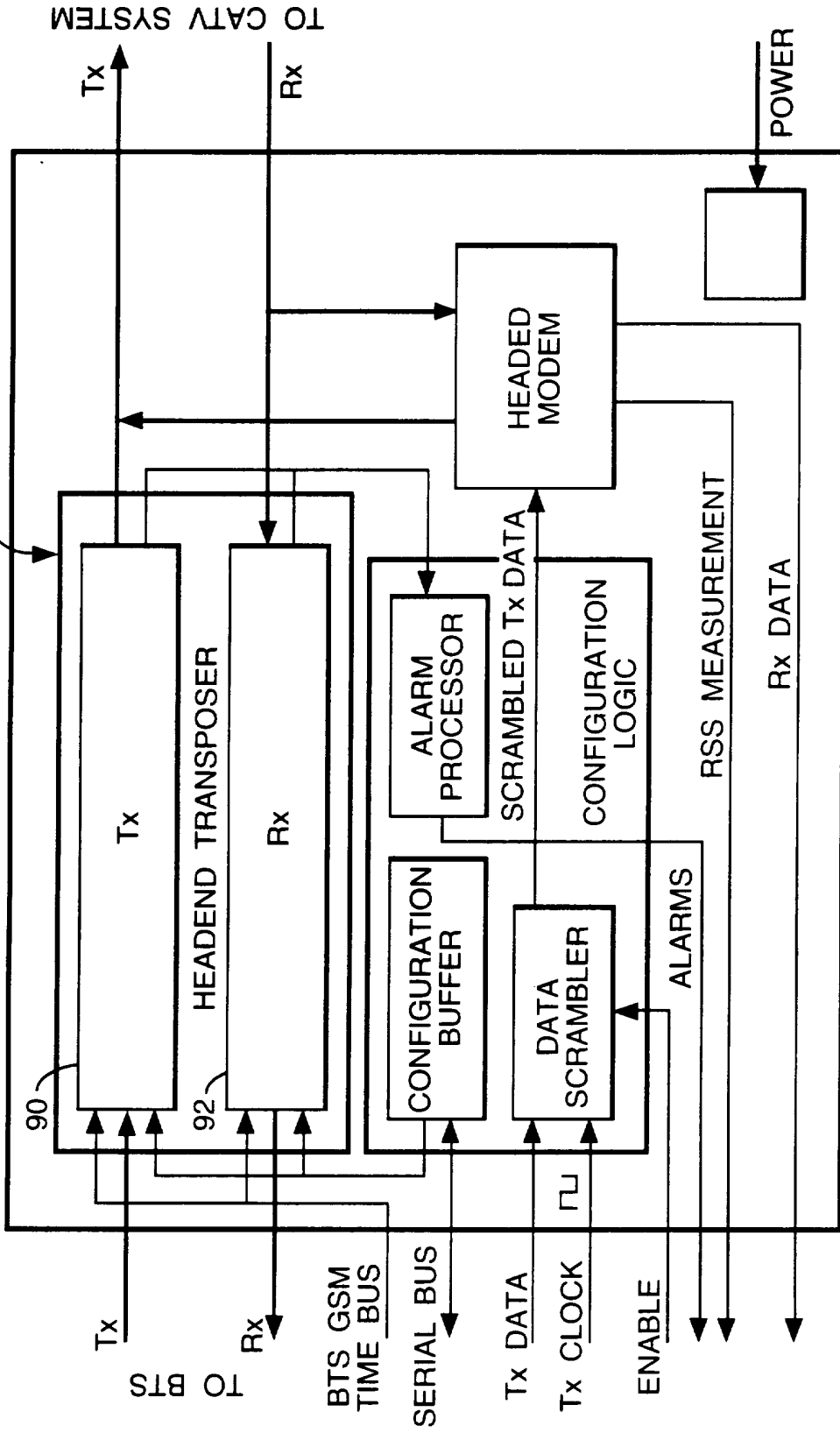

Fig.9.



COMMUNICATIONS SYSTEM

This invention relates to cable TV (CATV) systems and in particular to the provision of cellular radio communications via a CATV system.

5 Cable TV systems are becoming increasingly commonplace in urban areas where they provide a medium for the delivery of video services to customers. These systems have a large amount of spare bandwidth which the system providers can offer for the transport of additional services such as telephone traffic. A recent development of this telephony application has been a proposal to carry cellular
10 communications traffic, e.g. GSM or PCS traffic, over the cable network. In such an arrangement, a cellular base station is coupled via the cable network to a number of antennas to provide communication with mobile units in the service area of the antennas. A proposed system for cellular communication over a CATV network is described by R W Donaldson in
15 IEEE Transactions on Vehicular Technology, vol. 43 no. 3, pp666-70.

The potential use of CATV systems to carry cellular communications traffic has been restrained by a number of technical problems. Firstly, there is the problem of the limited dynamic range of most cable systems
20 which results in significant performance degradation when handling cellular communications traffic. A typical cellular system requires a nominal dynamic range of approximately 80 dB, whereas a typical cable system offers a dynamic range of about 30 dB for the downstream path or down link, and between 20 and 45 dB on the upstream path or uplink.
25 The 30 dB restriction on the down link is acceptable as cellular systems such as the GSM system can accommodate a signal to noise ratio as low as 9 dB. However, since the level at which uplink signals are directed into the cable system is dependent on the distance between a mobile terminal and its associated antenna, any dynamic range restriction on the

uplink results in a severe mismatch with the minimum sensitivity level of the cellular receiver. Under conditions that can be reasonably expected in a CATV system, this uplink dynamic range restriction reduces the effective transmission distance to an unacceptably low value. Secondly, cable systems intended for the transmission of mobile communications traffic are subject to the so-called near-far problem. Within a mobile system it is not possible to guarantee the signal level received at an antenna from a mobile. Consequently it is possible that low level transmissions from a wanted distant transmitter will be swamped by unwanted high power signals from a local transmitter operating on an adjacent channel. In a cable system, this problem is exacerbated by the inherent dynamic range limitation.

The object of the invention is to minimise or to overcome these disadvantages.

It is a further object of the invention to provide an improved communications system in which cellular communications traffic between mobile terminals and a base station is carried on a CATV network.

According to one aspect of the invention there is provided a cellular communications arrangement comprising a base station and a plurality of antennas coupled thereto via a cable communications network, said the antennas being arranged to operate in a simulcast mode, and wherein means are provided for compressing the dynamic range of cellular communications traffic carried on the cable network.

According to another aspect of the invention there is provided an arrangement for coupling a cellular communications base station with a plurality of mobile terminals via a CATV distribution network, the arrangement including a head end signal processor disposed at a head end of the CATV network and adapted to provide a first frequency conversion between a cellular communications radio frequency and a CATV network transmission frequency, a plurality of remote antenna drivers disposed at a remote end of the CATV network and adapted to provide a second frequency conversion between the cellular

communications radio frequency and the CATV network transmission frequency, and antennas one coupled to each said remote antenna driver for providing radio communications with said mobile terminals, wherein the remote antenna drivers are arranged in groups, the drivers
5 of each said group being operated on a common frequency in a simulcast mode, and wherein each said remote antenna driver incorporates means for compressing the dynamic range of cellular communications traffic carried on the cable network on an upstream path between the mobile terminals and the base station.

10 According to a further aspect of the invention there is provided a method of transmitting cellular communications traffic over a cable telecommunications network between a base station and a plurality of antennas, the method including operating the antennas in a simulcast
15 mode, and compressing the dynamic range of cellular communications traffic carried on the cable network.

The arrangement is intended for use with the GSM communications system, but it is not of course limited to that application.

20 Although the cable system carries traffic at allocated cable frequencies, the interfaces between the base station and the system head end and between the antennas and mobile terminals operate at the cellular system uplink and downlink frequencies. There is thus a transparent path
25 provided for mobile communications traffic between the base station and the mobiles and no significant modification of the cellular system is required.

30 An embodiment of the invention will now be described with reference to the accompanying drawings in which:-

Figure 1 is a general schematic diagram of a CATV system incorporating a cellular communications simulcast facility;

35 Figure 2 is a simplified schematic diagram of the system of figure 1 illustrating its interaction with an associated cellular communications system;

Figures 3a and 3b illustrate a typical cable frequency allocation plan for cellular traffic in the system of figure 1;

5 Figure 4 shows the construction of a remote antenna device (RAD) for use in the system of figure 1;

Figure 5 is a functional block diagram of the RAD construction of figure 4;

10 Figure 6 shows a radiation pattern employed by the RAD of figures 4 and 5;

15 Figure 7 is a block schematic diagram of the receive path of the RAD of figures 4 and 5;

Figure 8 is a graph illustrating the input/output characteristics of the RAD of figures 4 and 5 for uplink traffic;

20 Figure 9 shows the construction of a head end signal processor (HESP) for use in the system of figures 1 and 2; and

25 Figure 10 is a functional block diagram of the HESP of figure 9.

Referring to figure 1, the CATV system carries cable related traffic between a central CATV station 10, disposed at a head end 11, and a plurality of subscriber premises (not shown) via an optical fibre network 15 and a coaxial network 17. The system also carries cellular communications traffic between a cellular, e.g. GSM, base station 21, via a head end signal processor (HESP) 23 and a number of remote antenna drivers (RAD) 25 providing wireless communication with mobile terminals 27. Operation of the HESP and the RADs may be controlled by a processor (not shown) attached to the system. The RADs are operated in groups, the members of a group being operated on a

common frequency in a simulcast manner for uplink and downlink traffic. The effect of simulcasting is to merge the coverage areas served by each RAD in the cluster into a single simulcast cell within which a mobile terminal may roam without the necessity for handoff. Communication is thus effectively distributed throughout the simulcast cell. In the arrangement of figure 1, the system head end incorporates a number of HESPs each serving a respective set of RAD groups via a respective fibre network and each coupled to the cellular base station.

5

10 As is shown in figure 2, the base station 21 is controlled from a mobile switching centre 211 and a base station controller 212 forming part of a GSM network. It will be appreciated that, in the interests of clarity, only those parts of the GSM network that are essential to the understanding of the invention are illustrated in figure 2.

15

Referring to figures 1 and 2, on the downlink, each of the RAD's operating within a simulcast cluster transmits identical information to the mobile. In consequence, the mobile terminal receives several time shifted and attenuated versions of the same signal over the air interface.

20

This is analogous to multipath reception in a conventional system having only one antenna per cell and a GSM handset is adapted to accommodate and process received signals of this form via a channel equalisation technique. Thus, within the mobile terminal, the received signals are correlated and simulcast induced intersymbol interference

25

(ISI) is removed.

Simulcast operation on the uplink is similar to that described above. The signal transmitted from the mobile terminal is received by each of the RAD's in the simulcast cluster. Each RAD then transposes the radio signal to a frequency suitable for CATV upstream transmission. Since each RAD in the cluster operates on a substantially identical frequency both over the air interface and over the CATV network, the network itself is used to combine the uplink signals. At the system head end, the upstream cellur signals are converted or transposed back to the cellular traffic frequency by the HESP. At the base station, the simulcast signal is then processed and correlated to remove intersymbol interference. The use of simulcasting on the uplink significantly reduces the near-far

30

35

problem as a mobile terminal that is distant from one RAD in the group will, in general, be sufficiently close to another RAD of that group to provide an adequate signal. Further, as the RADs of the group have a single operating frequency, potentially interfering adjacent channel users will in general operate to distant RAD groups and will therefore be received only at low signal levels.

The number and disposition of the RADs, which are operated in a simulcast arrangement, will depend on the coverage requirements and the anticipated user density. The RADs may be configured to operate at the same frequency to form a single large simulcast cell or they may be divided into frequency groups to provide a number of smaller simulcast cells. The particular broadcast frequency will be determined by the licensing authority, but it is expected that the uplink will be in a band between 1850 and 1859 MHz and that the downlink will be in a band between 1930 and 1975, there being a 80MHz uplink/downlink duplex offset. Within each simulcast cell or cluster, the frequencies of the RADs are slightly offset from the nominal cell frequency typically by a value not exceeding 50Hz. We have found that this frequency offset is sufficient to ensure that any nulls within the simulcast cell persist for a maximum of a single data burst but not so large as to degrade the system performance.

The frequency allocation on the cable path will depend on the particular CATV network and on the location within the network. The reverse channel or back haul used for the uplink may be susceptible to HF interference and impulsive noise commonly referred to as ingress. Care will thus need to be taken to avoid frequencies with a high level of ingress. A typical frequency allocation plan for both the uplink and the downlink is shown in figure 3. In figure 3a, the uplink band allocation of 18 to 25MHz is derived from measurements which indicate a lower average ingress noise than other parts of the available spectrum. The gap at 21MHz avoids the currently allocated amateur radio band. Typically, the signalling channel operates at 18MHz occupying a 200kHz band. The remaining bandwidth may be used to transport the PCS traffic in 200kHz channels.

The downlink allocation (figure 3b) may be a 2MHz block disposed between 450 and 750MHz, the block being defined so as to coexist with the television channels that are carried by the network. The reference and signalling channels may be at 550 and 550.2MHz respectively.

5

The remote antenna device (RAD) is shown in figure 4 and its corresponding functional diagram is shown in figure 5. This device is coupled to the CATV network via a directional coupler and incorporates transmit (301) and receive (302) paths connected by diplex filtering (303, 304) to both the up and down links. The RAD is contained within a housing or enclosure comprises a remote transposer 31 providing an interface between the mobile radio and the CATV environments, a remote modem 32 which facilitates transmission of control data between the RAD and the system head end, and a remote controller 33. Communication between the RAD and the mobile terminals is effected via an antenna unit coupled to the RAD. The general functions of the RAD components or modules are detailed below.

10

15

The RAD Enclosure

20

The enclosure or housing comprises a mechanical structure containing the remote equipment. Advantageously, the housing is configured so as to be mounted on an overhead cable strand commonly used for equipment mounting in CATV systems. The housing can also be configured for mounting on a building or on a mast.

25

The Antenna Unit

This is used to radiate and receive the cellular radio signals and is mounted directly on the RAD enclosure.

30

The Remote Transposer

This module performs frequency transposition, filtering, amplification and dynamic range compression of the radio signals.

35

The Remote Controller

This module provides the control and configuration information for the RAD components and has four main functions:

The configuration and supervision of the RAD.

The provision of local configuration and monitoring via a RS232 standard interface 306 resident within the RAD.

5 The interpretation and formatting of digital information to be transmitted over the system control channels.

The performance of digital processing to extract a data clock from the downstream control signals.

The Remote Modem

10 This is used to facilitate the transmission and reception of digital control data between the DAS equipment at the system head end and the RAD. The remote modem is also used to recover the base station frequency reference which is distributed to all RADs via the network.

15

The Power Supply

This unit provides the power for all the RAD equipment. The unit receives its input power from a pseudo square wave signal that is provided by the CATV infrastructure.

20

A further function of the RAD is compression of the dynamic range of the mobile signals received over the air interface to match the limited dynamic range available over the CATV upstream path. Thus, the 80dB range typically required for conventional GSM traffic is compressed into a maximum of typically 45dB such that the -104dB minimum receiver sensitivity level specified within the GSM recommendations can be achieved.

25

30 A preferred radiation pattern for the RAD antenna is illustrated in figure 6. The pattern is generally omnidirectional which, when shown in cross-section as in figure 6, comprises two lobes so shaped that signals from mobiles close to the antenna are attenuated while signals from mobiles further from the antenna are provided with gain. The attenuation of signals from mobiles close to the antenna reduces the potential incidence of near-far interference

35

Figure 7 illustrates in schematic form the dynamic range compression technique employed in the RAD receive path. The path comprises an RF processing stage 61 coupled via a first mixer 62 to an IF processing stage whose input and output are provided with respective channel filters 63 and 64. The output from the IF processor is fed via a second mixer 65 to a CATV upstream frequency processing stage 66. A signal limiter stage 67 in the IF processing stage of the receive path is configured such that the RAD gain for low level signals is equal to the gain required for normal system operation, i.e. to compensate for the gain of the CATV signal path. However, signals received at or above a signal level of -60dBm are effectively clamped. In effect the system discards performance gains for high level signals and utilizes the available dynamic range for low level signals. In effect the system discards performance gains for high level signals and utilises the available dynamic range for low level signals. The typical RAD input/output characteristics providing this dynamic range compression are illustrated in Figure 8. We have found that this limitation of the dynamic range of the cellular traffic signals to a maximum value significantly reduces the dynamic range limitations of the cable system.

Referring again to Figure 7, the operation of the system is as follows. The uplink mobile signal is received via the antenna 66 and is isolated from transmitted signals within the circulator block 68. The RF signal is then filtered, amplified and down converted in the first mixer 62 to the intermediate frequency (IF). Dynamic range conversion then takes place. The IF signal is firstly filtered within the channel filter 63. This avoids the problems associated with adjacent channel interference which become particularly severe if signal limiting is employed. The signal is then amplified by IF amplifier 69 and limited by the limiter 67.

The process of limiting inevitably produces harmonics. These are removed by the second channel filter 64. The resulting signal is then converted to the required CATV upstream frequency in the second mixer 65 and again filtered and amplified before injection onto the CATV network. The local oscillators 71 and 72 associated with the first and second mixers respectively may be controlled in frequency from a pilot signal transmitted from the HESP at the system head end.

The construction of the head end signal processor (HESP) is shown in figure 9 and the corresponding functional diagram is shown in figure 10. In terms of signal processing, the HESP is similar in operation to the
5 RAD, although the HESP has much reduced control functionality and is used simply to process RF signals received from other system entities. In the case of mobile signals this involves transposing signals received from the BTS or or CATV system to predefined frequencies. In the case
10 of control data this involves either modulating signals from the head end system controller or demodulating signals received from the RADs.

Each of the BTS downlink signals is fed from the TRX associated with the HESP via a dedicated cable. This signal is fed to the transmit path
15 90 of the transposer 91 which in addition to frequency translation also performs filtering and amplification. This signal is then injected into the CATV network via a RF combiner. A downlink control channel is used to provide the RADs with configuration information, to poll the RADs for reports or alarms and to issue power up/power down commands.

20 On the uplink, the signals received on the receive path 92 from the CATV network are filtered to extract the mobile or cellular traffic which is then frequency converted to the cellular radio frequency and handed on to the base station.

25 To facilitate successful simulcasting, the gain of all the RADs in the simulcast cell as perceived by the base station is equalised. This may be achieved in the following way.

30 In the system, continuous HESP/RAD gain adjustment is provided on both the uplink and the downlink. The downlink gain may be controlled by the following mechanism.

35 The RAD continuously monitors its own signal output power and issues internal power up/ power down messages to regulate its output.

The HESP continuously monitors its own signal output power and issues internal power up/ power down messages to regulate its output.

- 5 The uplink gain is managed via the HESP and may be effected by the following mechanism.

The HESP polls each of the RADs with which it is associated

10

The HESP receives a response from each RAD. This response is processed and the received signal strength (RSS) on the upstream control channel is determined.

15

The HESP then determines from the received mobile signal strength the equivalent signal strength that would be received over the upstream information channel under conditions in which the received signal strength of the mobile is a maximum.

20

The power up/power down increment is determined by comparison of the required maximum RSS and received transformed RSS.

25

The result of the comparison is communicated to the RAD over the downstream control channel. The RAD then adjusts the power of both the control signal and the mobile signal.

- 30 The algorithm may be provided with a degree of hysteresis to prevent an unacceptably large number of power control commands.

In some applications there may be an advantage in operating the RADs in a simulcast cell in a quasi-synchronous manner e.g. to avoid persistent nulls in the cell. In such an arrangement the RAD synthesisers are designed such that a small offset frequency in excess of the 50 Hz offset discussed above can be provided. To overcome the consequential

35

performance degradation introduced by this offset, the local oscillators used on the uplink path are then provided with filtering so that oscillator far out phase noise does not contribute significantly to the noise floor of the receiver.

5

It will be understood that although the technique has been described with particular reference to the GSM cellular system, it is by no means limited to this particular system but is of general application to cellular communications systems in the provision of an interface between a base station and groups of antennas serving mobile terminals.

10

CLAIMS

1. A cellular communications arrangement comprising a base station and a plurality of antennas coupled thereto via a cable communications network, the system including means for operating groups of antennas each in a simulcast mode, and wherein the system includes means for compressing the dynamic range of cellular communications traffic carried on the cable network on an upstream path between the mobile terminals and the base station.
2. An arrangement for coupling a cellular communications base station with a plurality of mobile terminals via a CATV distribution network, the arrangement including a head end signal processor disposed at a head end of the CATV network and adapted to provide a first frequency conversion between a cellular communications radio frequency and a CATV network transmission frequency, a plurality of remote antenna drivers disposed at a remote end of the CATV network and adapted to provide a second frequency conversion between the cellular communications radio frequency and the CATV network transmission frequency, and antennas one coupled to each said remote antenna driver for providing radio communications with said mobile terminals, wherein the remote antenna drivers are arranged in groups, the drivers of each said group being operated on a common frequency in a simulcast mode, and wherein each said remote antenna driver incorporates means for compressing the dynamic range of cellular communications traffic carried on the cable network on an upstream path between the mobile terminals and the base station.
3. An arrangement as claimed in claim 2, wherein the remote antenna drivers of a said group are provided each with a frequency offset from said simulcast frequency whereby to prevent the generation of local signal nulls.
4. An arrangement as claimed in claim 2 or 3, wherein each said antenna has a radiation pattern such that signals from mobile terminals close to that antenna are attenuated and signals from mobile terminals

remote from the antenna are provided with gain whereby to provide a perceived signal level which is substantially distance independent.

- 5 5. An arrangement as claimed in claim 2, 3 or 4, wherein each said remote antenna device has means for adjusting the gain of upstream signals to the head end signal processor such that the signals received by the baser station from the remote antenna devices are of substantially uniform signal strength.
- 10 6. An arrangement for coupling a cellular communications base station with a plurality of mobile terminals via a CATV distribution network substantially as described herein with reference to and as shown in the accompanying drawings.
- 15 7. A method of transmitting cellular communications traffic over a cable telecommunications network between a cellular communications base station and a plurality of antennas serving mobile terminals, the method including operating the antennas at a common frequency in a simulcast mode, and compressing the dynamic range of cellular
20 communications traffic carried on the cable network on an upstream path between the mobile terminals and the base station.
8. A method as claimed in claim 7, wherein the antennas are provided each with a frequency offset from said simulcast frequency
25 whereby to prevent the generation of local signal nulls.
9. A method as claimed in claim 7 or 8, wherein each said antenna has a radiation pattern such that signals from mobile terminals close to that antenna are attenuated and signals from mobile terminals remote
30 from the antenna are provided with gain whereby to provide a perceived signal level which is substantially distance independent.
10. A method as claimed in claim 7, 8 or 9, wherein the gain of
35 upstream signals to the head end signal processor such that the signals received by the base station from the antennas are of substantially uniform signal strength.

11. A method of transmitting cellular communications traffic over a cable telecommunications network substantially as described herein with reference to and as shown in the accompanying drawings.



Application No: GB 9608913.1
Claims searched: 1-11

Examiner: Mr B J Spear
Date of search: 17 July 1996

**Patents Act 1977
Search Report under Section 17**

Databases searched:

UK Patent Office collections, including GB, EP, WO & US patent specifications, in:
UK CI (Ed.O): H4L (LDA); H4R (RCC)
Int CI (Ed.6): H04B 7/26; H04H 1/02; H04Q 7/30,7/38
Other: Online: WPI

Documents considered to be relevant:

Category	Identity of document and relevant passage	Relevant to claims
X	EP0526285A2 (Cable Television Labs. Inc) Whole document, eg Figs. 1 and 2 and col. 3 line 49 to col. 6 line 38.	1,2 and 7 at least.
X	WO92/13400A1 (Rogers CableTV) Whole document, eg Figs. 1-3 and page 22 line 10 to page 29 line 14	1,2 and 7 at least

X	Document indicating lack of novelty or inventive step	A	Document indicating technological background and/or state of the art.
Y	Document indicating lack of inventive step if combined with one or more other documents of same category.	P	Document published on or after the declared priority date but before the filing date of this invention.
&	Member of the same patent family	E	Patent document published on or after, but with priority date earlier than, the filing date of this application.