

W. A. HEILPRIN.
 AIR GUN.
 APPLICATION FILED NOV. 30, 1908.

944,188.

Patented Dec. 21, 1909.

2 SHEETS—SHEET 1.

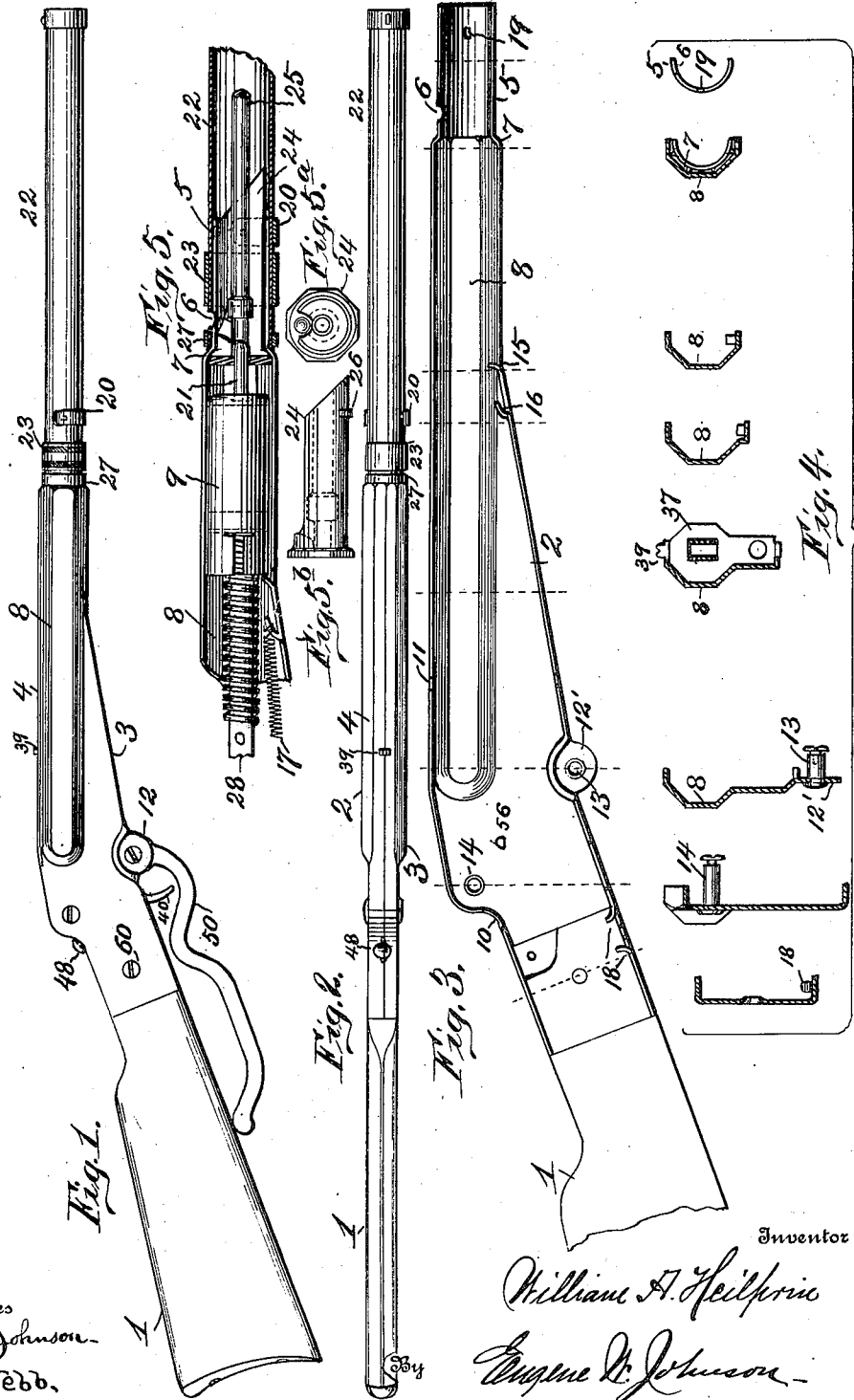

Witnesses
 J. C. Johnson
 C. E. Webb.

Inventor
 William A. Heilprin
 Eugene D. Johnson
 Attorney

W. A. HEILPRIN.
AIR GUN.

APPLICATION FILED NOV. 30, 1908.

Patented Dec. 21, 1909.

2 SHEETS—SHEET 2.

944,188.

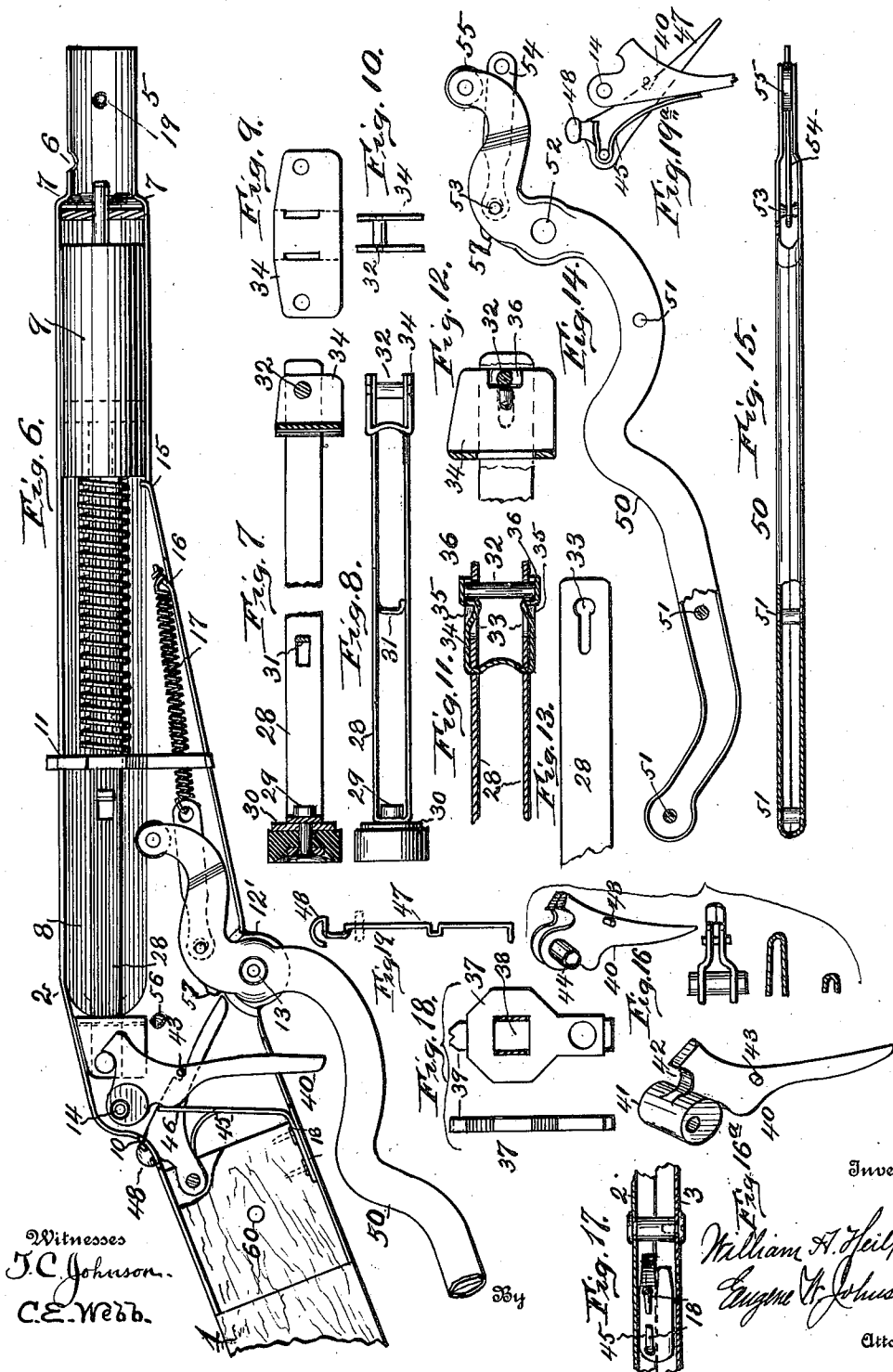

Witnesses
J.C. Johnson.
C.E. Webb.

Inventor

William A. Heilprin
Engineer

Attorney

UNITED STATES PATENT OFFICE.

WILLIAM A. HEILPRIN, OF PHILADELPHIA, PENNSYLVANIA.

AIR-GUN.

944,188.

Specification of Letters Patent.

Patented Dec. 21, 1909.

Application filed November 30, 1908. Serial No. 465,301.

To all whom it may concern:

Be it known that I, WILLIAM A. HEILPRIN, a citizen of the United States of America, residing at Philadelphia, in the county of Philadelphia and State of Pennsylvania, have invented new and useful Improvements in Air-Guns, of which the following is a specification.

The invention forming the subject matter of this application relates to that type of air-guns in which a lever retracts a piston-rod to compress the driving spring thereof, the initial rearward movement of the piston carrying with it the cylinder for the piston and a tube attached thereto so as to admit a shot or pellet from a magazine to a point in the rear of the barrel, such type of air-gun being known as the "Columbian air rifle".

The object of this invention is to provide an air-gun, lighter in weight and safer than those heretofore made, the parts thereof being constructed to be as effective in operation and more accessible than in air-guns heretofore manufactured, and in the make-up of an air-gun to accord with my invention the lever, the trigger and other parts are mounted on one section of the housing, the other side of the housing being readily removable so that access may be had to the operating mechanism without displacing the same, as will be hereinafter set forth or pointed out in the claims.

The invention further consists in the particular construction of the parts and in the combination thereof, including a housing made up of two side pieces, one of said side pieces carrying means for attaching thereto the lever and the trigger.

In the accompanying drawings Figure 1, is a side elevation of an air-gun made in accord with my invention. Fig. 2, is a top plan view. Fig. 3, is a side elevation of one of the sides of the housing. Fig. 4, is a series of cross sections taken on the dotted lines indicated on Fig. 3. Fig. 5, is a detail view with one of the sides of the housing removed. Fig. 5^a, is a rear elevation of the shot-race. Fig. 5^b, is a side elevation of the shot-race. Fig. 6, is a side elevation, one of the sides pieces of the housing being removed. Figs. 7, to 10, are views of the piston-rod. Figs. 11, 12 and 13 are detail views of modifications of the piston-rod. Fig. 14, is a side elevation, partly broken away of

the lever. Fig. 15, is a top plan view partly in section of the lever. Fig. 16, is a view of the preferred form of trigger. Fig. 16^a, is a view of a modified form of the trigger. Fig. 17, is a sectional detail of the spring for the trigger and the safety device. Fig. 18, is a side and a plan view of the abutment for the piston-actuating-spring. Fig. 19, is an end elevation of the safety device and Fig. 19^a is a modification of the safety-device.

The stock 1, has its fore-end reduced to receive the rear ends of the side pieces 2, and 3, which constitute the housing 4, the same being attached to the fore-end of the stock by screws 60, and if desired the fore-end of the stock may be cut away as shown in Fig. 6, to receive the rearward extending portion of a safety device, that is depressed before the trigger can be moved to release the piston. The side pieces 2, and 3, which together constitute a housing 4, for the movable parts of the operating mechanism are made up from two similarly shaped pieces of sheet metal, each piece shaped to provide at the fore-end semi-cylindrical or segmental ends 5, each being cut away to provide an opening 6, through which the shot may be passed to the magazine, the extensions 5, having recesses or perforations 19, with which prongs or pins on a clip 20, engage to hold the magazine against removal when the clip is in place. The semi-cylindrical extensions 5, are integral with the side pieces, there being present a shoulder 7, and the side pieces from the shoulder rearward are made up to provide a guiding and covering casing for the cylinder, the piston and the spring that drives the piston. The projecting portion 8, of the side pieces extends from the shoulders 7, rearward to a point above the fulcrum of the lever, and said parts 8 may be semi-octagonal, polygonal or semi-circular in cross section or of other shape to provide a support and guide for the cylinder 9, and to overlie the piston-rod and its spring.

The inward projecting edges of the side pieces 2, and 3, will abut when the gun is assembled, and in advance of where the stock enters a socket formed by the side pieces there is formed an ogee curve that connects or is between the inclined upper edges of the housing. The upper edge of each side piece is recessed at 10, to provide

an aperture through which is passed the upper end of a safety device, and at 11, for the passage of the upper end of the abutment. The lower edges of the side plates have downward extending lugs 12, and 12', the distance between the inner faces of the lugs being less than the distance between the adjacent parts of the side pieces 2 and 3, the formation providing an opening for the passage of the lever. The lug 12' of the side piece 2 has fixedly attached thereto a pin 13, that serves as a fulcrum for the lever, and a similar pin 14, is attached to the side piece 2 having mounted thereon the trigger, these pins being recessed to receive screws.

The lower edge of the side piece 2, is struck up to provide a stop 15, with which the end of the cylinder will engage when retracted and adjacent thereto is a prong 16, to which one end of the lever-spring 17, is attached, and if desired the trigger-spring 45, may be secured to the side piece 2, by prongs 18, they being passed through apertures in said spring after which they are bent to overlie the upper surface of the spring adjacent to the openings there-through, and when the prongs 18, are not present tacks or nails are used to attach the trigger spring to the stock 1, as indicated by dotted lines, see Fig. 6. The side pieces 2, and 3, are each recessed to receive the abutment and have apertures for the passage of screws that attach the stock to the side pieces of the housing.

The side pieces 2, and 3, may be varied as to shape, the principal feature thereof being to provide a two piece housing of such construction that the edges thereof will abut and in which the division line, on the upper side will be longitudinal and central.

The cylinder 9, is of the construction such as has been used in the "Columbian air rifle", and when the cylinder is moved rearward by its piston, it will engage with the stop 15, and in the rearward movement of the cylinder the tube 21, opens the way for the shot from the magazine 22. The magazine is loaded through the opening formed by the recesses 6, 6, and a registering opening in the magazine such opening being covered by a movable band 23, carried by the magazine. The spring-clip 20, is provided with inward projecting studs or pins that pass through perforations in the magazine and engage perforations or recesses in the extensions 5. This clip not only serves to hold the magazine in place against longitudinal displacement, but also serves to limit the forward movement of the band 23, upon the magazine.

The shot-race has at its rear end a flange shaped to correspond with the internal configuration of the forward end of the outwardly pressed portion of the side pieces, and as the shape is otherwise than circular,

the shot-race will be held against turning, the shoulder 7, preventing forward movement of the shot-race. The shot-race 24, may be struck up out of sheet metal or it may be cast in one or two pieces, and the same has a recess to receive an enlargement upon the rear end of the barrel 25, and a rib 26, to engage the forward end of the reduced portion 5, of the side sections. The construction of the shot-race and the side pieces is such that the shot-race will be held against longitudinal and rotary movement.

The magazine 22, has placed over its rear end a band 27, which is of slightly smaller diameter than the movable band 23, said band 27, serves to provide a finish between the shoulder 7, and the magazine tube, it also prevents expansion of the magazine tube.

The piston-rod or bar 28, is made up of a flat strip of metal bent to provide parallel side members which are secured to the piston by a rivet 29, one end thereof being upset over a washer 30. The side bars of the piston-rod are held apart or against compression by one or more spurs or prongs 31, which are integral with one of the side members and engage the inner side of the opposite side member. Instead of the integral spurs or prongs 31, a rivet or rivets may be substituted therefor. The rear ends of the side bars of the piston-rod are apertured for the passage of a pin or roller 32, and it is with this pin that the trigger engages to hold the piston-rod when the spring is compressed. As shown by Fig. 13, the side bars have key-hole slots or openings 33, the enlarged ends receiving the ends of a steel or hard metal pin 32, that is held in the openings 33, by the overlying side pieces of a plate 34. The plate 34 is made slightly concave between the side pieces of the piston-rod, and it has vertical slots for the passage therethrough of the ends of the side bars of the piston-rod. The parallel sides of the plate 34, in line with the key-hole slots 33 have inwardly pressed portions or catches 35, which enter the slots, and to the rear of the catches are outwardly pressed portions 36, which overlie the end of the roller or pin 32, so that the plate 34, holds the side-bars of the piston-rod in parallel relation, and maintains the pin or roller that is engaged by the trigger so that it may turn in its supports.

The plate or abutment 37, with which the spring of the piston-rod engages is shaped so that the exterior configuration of the sides of the plate will be the same as the interior shape of the sides of the housing, at the point of its attachment, and the abutment plate has an opening 38 for the passage of the piston-rod, and may have a smaller opening or recess in line therewith for the passage of the retracting spring 17, of the lever. The upper portion of the plate 37, extends

through the opening 11, above the housing to provide a rear sight 39, and the lower end of the plate is engaged by the lower edge of the housing. The plate 37, serves as a bearing for the spring of the piston-rod, as a rear sight and prevents the sides of the housing being compressed so that the edges thereof will overlap.

The trigger 40, when made as shown by Fig. 16^a, has side bosses or lateral extensions 41, a hook 42, with which the roller 32 of the piston-rod engages, and below the fulcrum of the trigger the projecting portions against which the trigger spring will bear. The trigger is also provided with a laterally projecting pin 43, that engages a notch or projection on the safety device. As shown by Fig. 16, the trigger may be made of sheet metal, a single piece being bent to provide a catch for the roller, an incline upon which the roller will ride, and the apertured sides may carry a tube 44, that takes the place of the bosses 41. The trigger spring 45, is slit at its upper end so that one of its end portions 46, engage the trigger below its fulcrum, the other member of the spring engaging the safety device or latch 47, or the same may be made as shown by Fig. 19^a. The safety device or latch 47, has at one end thumb-piece 48, located in use above the slot 10, and when the thumb-piece is pressed upon the safety device, will be moved upon its fulcrum to position the notch or projection formed therein out of the path of the pin 43; on the trigger. The lower end of the safety device lies in the path of a pin or projection 57 adjacent to the fulcrum of the lever 50, and when the lever is moved to force the piston-rod rearward, the safety device is moved rearward so that the trigger may be moved upon its fulcrum, the roller 32, engaging the inclined portion of the trigger prior to dropping into the catch.

The combined lever and trigger guard 50, is made up of two similar side pieces, which beyond the housing are oval in cross section, such side pieces being held together by means of shouldered rivets 51, and beyond the perforations 52, through which the stud 13, passes to provide the fulcrum for the lever, there is a centrally reduced stud or rivet 53, that centers a link 54, the other end of said link being attached to the spring 17. The inner end of the lever carries a roller 55, and the side pieces of the lever adjacent to such roller are bent inward to reduce the width so that the end and roller may readily press between the bars of the piston-rod, to engage the concave portion of the plate 34.

The housing below the plate 34, when positioned to be engaged by the trigger has inward projecting portions 56, to prevent the plate being moved downward when the trigger is pulled upon to release the piston-rod. It will be noted that when the lever

is moved to compress the spring that drives the piston, the lever on the stud or projection 57, will engage and move the safety device so that the trigger is moved by the roller on the plate attached to the piston-rod.

It will be noted that in the make-up of a gun in accord with my invention the aim has been to make the parts as light as possible and reduce the cost of the manufacture, and at the same time provide an air-gun which can be readily taken apart by removing first the barrel or magazine tube and the screws that connect one of the side pieces to the studs 13, and 14, as well as the screw that attaches the side piece to the stock.

The operation is similar to the "Columbian air rifle" which is manufactured under Letters Patent No. 487,169, dated Nov. 29, 1882. No. 603,549, dated May 3, 1893. No. 507,470, dated October 24, 1893 and No. 906,420, dated December 8, 1908. To load the magazine, the ring or band 23 is moved toward the muzzle of the gun a distance sufficient to uncover the opening 6, the shot or pellets being fed through such opening to the longitudinal way or recess in the shot race, and as the gun is held muzzle downward in loading, the magazine, the shot will roll into the magazine occupying the space between the barrel and the magazine. To charge the barrel or to load the gun, the barrel is raised and a single shot will be fed from the magazine through the way of the shot race, and as the cylinder is retracted by the lever the tube 21, at the end of the cylinder permits the shot to occupy the space immediately in the rear of the barrel. Rearward movement of the piston by the lever causes a movement rearward of the cylinder, and before the piston-rod completes its full movement rearward the lever will have contacted with the forward end of the safety device to move and hold the same out of the path of the projection on the trigger, so that the trigger may be moved by the cross bar which engages the catch portion of the trigger, and when the lever is released or moved toward the stock the safety will resume its normal position.

It will be noted that the safety device is placed out of engagement with the trigger when the lever is swung forward to retract the piston in charging or loading the gun, and that such safety device is normally in engagement with the trigger, so that the trigger can not be pulled or moved to release the piston until the same is moved by pressure upon the knob or end portion that extends through the casing in position to be pressed forward or rocked by the thumb when a finger is in position to pull the trigger. The construction provides a safety device for air guns in which the thumb has to hold the safety out of its normal position when the trigger is pulled to release the pis-

ton, and as soon as pressure is removed from the safety device it will move to lock the trigger.

5 The external part of the safety device is positioned so that when the stock is grasped in position for sighting the thumb will naturally engage and move the safety device out of the path of the pin on the trigger.

I claim—

10 1. In a gun of the type set forth, sheet-metal side casings one of the sides having permanently attached studs, a lever mounted upon one of the studs and a trigger mounted upon the other stud, the other side
15 of the casing having in line with the studs apertures and means for attaching such side of the casing to the studs.

2. In a gun, a pair of sheet metal side casings, studs fixedly attached to one of the side casings said studs having internally threaded recesses, a side casing having apertures therethrough which register with the studs, and screws the heads of which overlie the casing about the apertures when in engagement with the studs.

3. In a gun, a pair of sheet-metal side pieces which when connected constitute a casing having parallel portions, lugs on each of the side pieces which are bent inward to be out of line with the side pieces and to be nearer together than said side pieces, a stud attached to one of the lugs, the opposite lug having an aperture therethrough, a lever mounted upon the stud and means for connecting the apertured lug to the stud.

4. In a gun, sheet-metal side casings each having parallel sides from which depend lugs that extend inward and then downward to a point below the plane of the side casings, a stud which is fixedly attached to one of the lugs, a lever of a width to occupy the space between the lugs said lever being fulcrumed upon the stud and means for attaching the other lug to the stud.

5. In an air gun, a magazine tube, sheet metal side casings which are held together at their forward ends by the magazine tube, means for connecting the side casings one to the other at intermediate points and a stock to which the rear ends of the side casings are attached.

6. In an air-gun, a magazine tube, sheet-metal side casings which are held together at their forward ends by the magazine tube, and means for connecting the side casings one to the other at their rear ends, and at intermediate points.

7. In an air gun, a housing made up of sheet-metal side plates each plate being shaped to provide reduced fore-ends, a magazine tube one end of which engages the reduced fore-ends of the side plates, longitudinal enlargements in the rear of the fore ends, a cylinder, a piston and a spring therefor mounted within such longitudinal en-

largements, flat sides below and in the rear of the longitudinal enlargements for the reception of a lever, a trigger and springs therefor, and means for connecting the side plates such means also serving as fulcrums for the lever and the trigger.

8. In an air-gun, a housing made up of side plates each being provided at its fore-end with a reduced portion which is overlaid by the end of a magazine tube, longitudinal enlargements that extend rearward from the reduced portion of the side plates, straight sides that extend below and to the rear of the longitudinal enlargement, the side plates having inturned edges which abut, and connecting means, such connecting means providing fulcrums for a lever and for a trigger.

9. A gun having a cylinder, a piston and an actuating spring therefor, two side pieces between which such parts are mounted and incased, a magazine tube connecting the fore-ends of the side pieces, a stock to which the rear ends of the side pieces are attached, and studs fixedly attached to one of the side pieces to provide fulcrums for the lever and trigger.

10. In a gun, sheet-metal side pieces, the edges thereof having recesses, an abutment seated in said recesses and shaped to conform to the interior configuration of the side pieces in line with the recesses, and openings through the abutment for the passage of a piston rod and for a spring that engages the operating lever for the piston rod.

11. A trigger made up of a single piece of sheet-metal comprising rearward extending portions which are apertured for engagement with a pivot pin, and an inclined portion positioned in advance of the catch, substantially as shown.

12. A trigger made up of a single piece of sheet-metal and provided adjacent to its fulcrum with laterally extending bosses, a hook, an inclined portion extending from the upper end of the hook downward, and means below the fulcrum of the trigger for engagement with a latch, substantially as shown.

13. In a gun, a trigger, a spring actuated reciprocatory member that is movable to be engaged by the trigger, a lever for moving said member toward the trigger, a trigger lock which is normally held in engagement with the trigger to hold the trigger against movement said trigger lock being pivoted within the casing of the gun and having a part that extends through the casing on the side opposite the trigger; the inner end of the trigger lock being positioned to be engaged by the lever when the same is actuated to move the reciprocatory member toward the trigger.

14. In a gun, a trigger, a spring actuated

- lock for said trigger made up to provide a part that extends through the casing of the gun on the side opposite to which the trigger projects to provide means for manually moving the lock against the action of its spring to release the trigger, a lever for moving a part that is restrained by the trigger said lever engaging the lock and moving the same prior to contact of the trigger engaging part of the trigger.
15. In a gun, a trigger, a device for locking the trigger having a part that projects through the upper side of the casing of the gun to provide means for manually operating said device, a spring that normally holds the locking device in position to be engaged by the trigger and a movable member having a part within the casing that engages the locking device to move the same out of the path of the trigger.
16. In a gun, a trigger having a catch portion for retaining a piston, means on the trigger for engagement with a safety device, a safety device having a part which is normally held to be engaged by the means on the trigger and a part that is manually moved to position such part out of the path of the part on the trigger.
17. In a gun, a combined lever and trigger guard having parallel end portions within the casing of the gun, a link maintained in swinging engagement with the end portions of the lever and trigger guard; the link being of a length sufficient to extend beyond the parallel end portions of the lever and trigger guard and a spring attached at one end to the end of the link and at its other end to the casing of the gun.
18. In a lever and trigger guard, a link having apertured ends, and a rivet having a centrally reduced portion upon which the link is mounted for the purpose of centering the link upon the rivet.
19. A combined lever and trigger guard for guns, comprising connected side plates; the trigger guard and grasping portion of the lever being oval in cross section, parallel end portions beyond the fulcrum of the lever, and a roller maintained between said end portions.
20. A combined lever and trigger guard made up of two side plates which are connected one to the other by rivets, to provide the external member with a part which is oval in cross section, the inner member having substantially flat and parallel side pieces, a link pivoted between the side pieces, and a roller carried by the ends of the side pieces, substantially as shown.
21. In an air-gun of the type shown, side plates having inward extending flanges, said flanges having recesses for a combined spring abutment, and rear sight, an opening for the passage therethrough of a lever, an opening through which projects the lower end of a trigger, and above said opening an opening for the passage therethrough of the manually operated member of a safety device.
22. In an air-gun of the type shown, the combination with a lever having at one end a roller, of a piston rod having a plate attached to the ends of the side pieces of the piston rod, said plate having a vertical portion, which extends beyond the upper and lower edges of the piston rod.
23. A piston rod for air guns, comprising sheet metal side members each having apertures through their end portions, a transverse member which is passed through the apertures and a plate that is engaged by a lever and is held in place by the transverse member.
24. In an air-gun, a piston rod having side bars made up of a continuous piece of sheet-metal, a roller engaging plate apertured for the passage of the ends of the side bars and a roller with which the trigger engages, held against lateral movement by the side wings of the attached plate.
25. A piston rod for air-guns, having a spring incased part and means integral with the side plates of the piston rod for preventing compression thereof.
26. A piston rod provided at its ends with key-hole slots, a plate apertured for the passage of the ends of the piston rod, and provided with inwardly pressed portions to enter the slots, and outwardly pressed portions to overlie the ends of a trigger engaging roller, for the purpose set forth.
27. In combination with a trigger and a safety device for engagement therewith of a spring provided with independent acting ends that engage the safety device and trigger, substantially as shown.
28. In an air-gun, a shot-race which is provided at its rear end with a circumferential flange that is adapted to abut against shoulders formed on the side casing, the part of the shot-race beyond the flange being embraced by a reduced portion of the casing, substantially as shown.
29. In a gun, the combination with side casings, of a magazine tube, adapted to overlie the forward ends of the casings, a stock attached to the rear end portions of the casings, studs attached to one of the side pieces to provide supporting means for the trigger and lever of the gun, recesses in said side casings, and an abutment which engages the casings about said recesses.
30. In an air gun, the combination with the sheet metal side casings shaped to provide a chamber for a longitudinally movable cylinder, a stop on one of the side casings with which the cylinder will engage to limit its movement rearward, a cylinder, a piston

for the cylinder, a plate attached to the end of the piston rod opposite the piston, a lever fulcrumed to engage the plate to retract the piston rod, a trigger for holding the piston rod retracted and a projection which extends inward to be below the plate to prevent downward movement of the plate when the trigger is moved to release the piston rod.

31. In a gun, a spring actuated trigger provided below its fulcrum with a laterally extending portion, a safety device or lock for the trigger which is normally maintained in engagement with the laterally extending portion of the trigger and means for moving the safety device out of the path of the laterally extending portion of the trigger.

32. In a gun, a trigger that is spring actuated in one direction, a lock for the trigger, a spring for holding the lock in engagement with the trigger, a part integral with the lock that extends through the casing of the gun on the side opposite from which the trigger projects, and a manually operated lever which when moved upon its fulcrum engages a part of the lock within the casing to move the lock out of the path of the trigger.

33. In a gun, a spring actuated trigger, a spring actuated locking device therefor one end of the locking device extending through the casing of the gun for manually moving the locking device against the action of its spring, and means within the casing for engagement with the locking device to move

the locking device out of the path in which the trigger moves.

34. In a gun, a trigger, a spring actuated lock therefor, a piston rod that engages the trigger when retracted, and movable means for retracting the piston rod, said means also actuating the lock to permit movement of the trigger.

35. In a gun, a trigger, a pivoted locking pawl having a part that is normally positioned in the path of the trigger to hold the trigger against movement, a part on the pawl that projects exteriorly to be manually engaged to place the trigger engaging part of the pawl out of engagement with the trigger, a piston rod having means for engagement with the trigger, a lever for moving the piston rod against the action of its spring such lever also actuating the pawl to release the trigger so that it may engage the piston rod.

36. In a gun, a trigger having thereon a catch for engagement with a piston rod, a lever for moving the piston rod so that it may engage the trigger, a spring actuated locking device for the trigger having a part that is engaged by the lever to release the trigger so that the piston rod may engage therewith and exteriorly extending means on the pawl for manually moving the same to release the trigger.

WILLIAM A. HEILPRIN.

Witnesses:

MAUDE LOCKWOOD,
ALMA J. HARRISON.