

Dec. 29, 1931.

W. A. J. KREAGER

1,838,266

RETORT OR HEATER FOR USE IN HEATING LIQUIDS

Filed Aug. 24, 1928

2 Sheets-Sheet 1

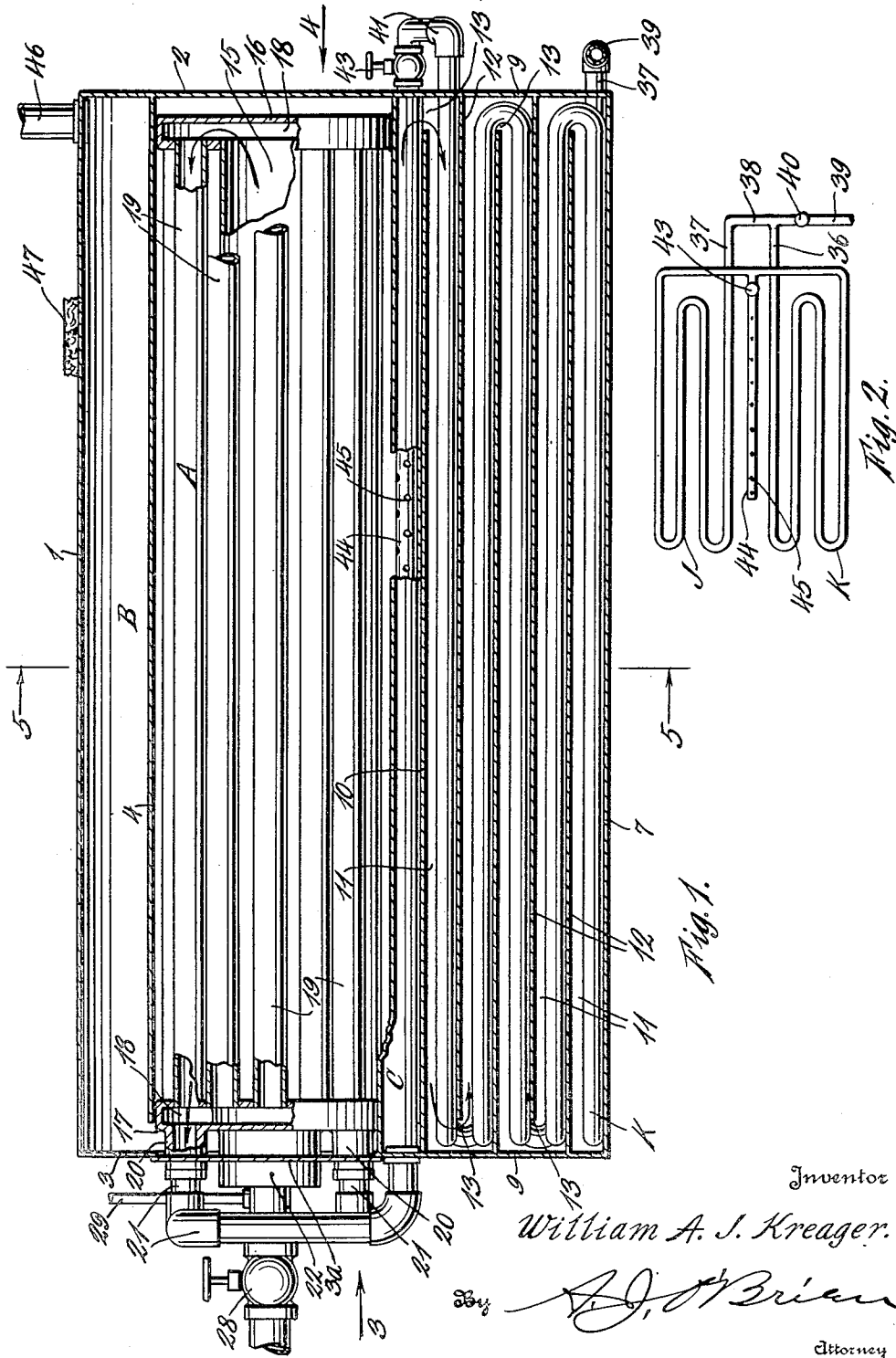

Inventor

William A. J. Kreager.

*A. J. Brian*

Attorney

Dec. 29, 1931.

W. A. J. KREAGER

1,838,266

RETORT OR HEATER FOR USE IN HEATING LIQUIDS

Filed Aug. 24, 1928

2 Sheets-Sheet 2

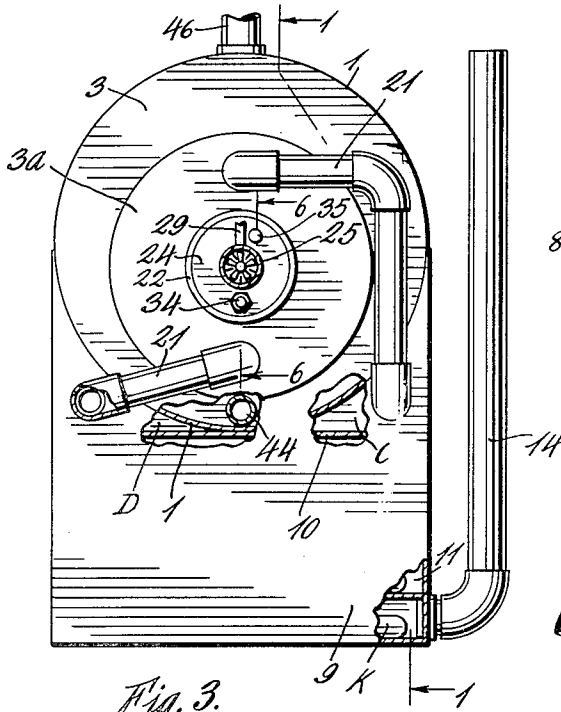

Fig. 3.

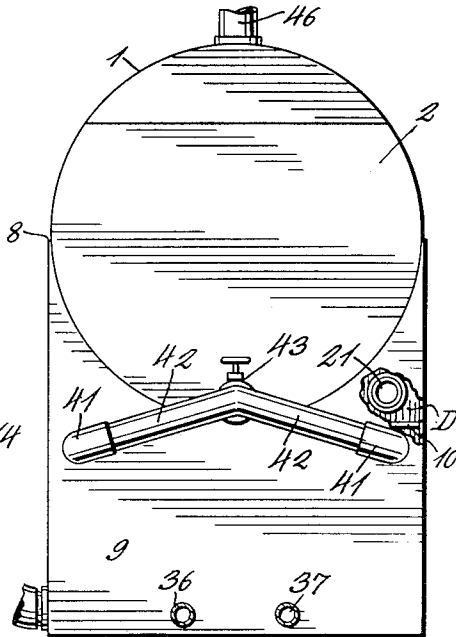

Fig. 4.

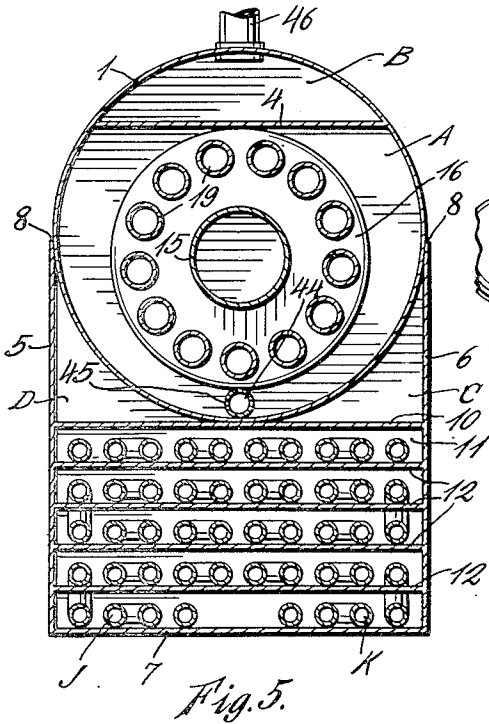

Fig. 5.

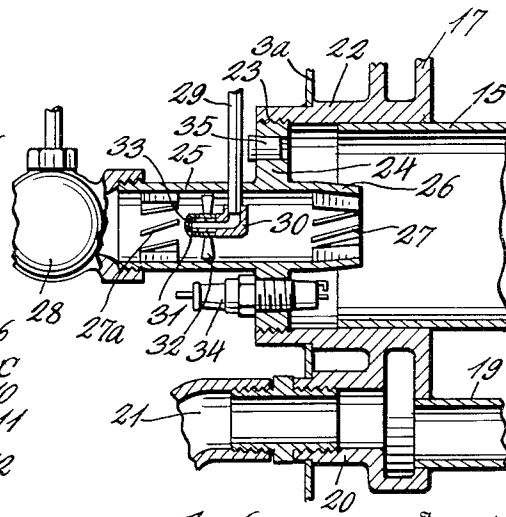

Fig. 6.

Inventor

William A. J. Kreager.

384 *L. O'Brien*

Attorney

# UNITED STATES PATENT OFFICE

WILLIAM A. J. KREAGER, OF DENVER, COLORADO, ASSIGNOR, BY MESNE ASSIGNMENTS,  
TO BARQUE ROYALTY, INC., OF DENVER, COLORADO, A CORPORATION OF COLORADO

## RETORT OR HEATER FOR USE IN HEATING LIQUIDS

Application filed August 24, 1928. Serial No. 301,894.

This invention relates to improvements in retorts or heaters for use in heating liquids and has reference more particularly in a heater for use in heating heavy oils, such as are employed in road construction and for similar purposes.

It is the object of this invention to produce a heater of a simple construction that can be used on the surface of the ground and which will very quickly heat a large amount of heavy oils with a small expenditure of fuel.

In handling heavy oils containing tar and asphalt, it is necessary to heat these oils before they will flow freely and it is for this purpose that this heater is primarily intended.

Fig. 1 is a longitudinal section taken on line 1—1, Fig. 3, with parts broken away so as to more clearly disclose the construction;

Fig. 2 is a diagrammatic representation of the pipe coils that are located in the flue passages;

Fig. 3 is a front end view of the retort with parts broken away;

Fig. 4 is a rear end view of the retort;

Fig. 5 is a section taken on line 5—5, Fig. 1; and

Fig. 6 is a section taken on line 6—6, Fig. 3.

In the drawings reference numeral 1 indicates a cylinder having its opposite ends closed by means of plates 2 and 3. Plate 4 divides the interior of the cylinder into two compartments. This plate is located to one side of the axis of the cylinder so as to form a chord and therefore divides the interior into a large and a small compartment which has been designated respectively by letters "A" and "B". The cylinder is supported by the side walls 5 and 6 of a heated chamber whose bottom has been indicated by reference numeral 7. The upper edges of walls 5 and 6 are preferably electrowelded to the cylinder along lines 8 so as to form a tight joint between the two. The ends of this heated chamber are closed by means of end plates 9. A transverse plate 10 extends longitudinally of the heated chamber directly underneath the cylinder 1 and extends the entire length of the heated chamber so as to separate the space below this plate entirely from the space

above it. The space above plate 10 will, of course, be divided into two similar compartments "C" and "D", which are separated both from the interior of the cylinder and from the space below the plate 10. As the cylinder is not welded or otherwise attached to the upper surface of plate 10, compartments "C" and "D" are not sealed from each other, but leakage may take place to some extent, as this is immaterial. That part of the heater chamber below plate 10 is divided into a plurality of thin wide flue passages 11 by means of plates 12, which are parallel, but which are each somewhat shorter than the length of the heated chamber so as to provide openings 13 at opposite ends, whereby the separate passages will be connected in series so that air or gases which are caused to flow through one will have to flow through all of these passages. The flue passages have one end in communication with the flue above and the opposite end in communication with the flue directly beneath, while the lowermost flue is connected to the atmosphere through a pipe 14. Located within the compartment "A" of cylinder 1, is a heater comprising an elongated tubular member 15, which has been shown as of cylindrical cross section, but which may, of course, be of any other suitable cross section and two headers 16 and 17, which are preferably made of cast iron and are drum shaped. These headers are hollow so that each has a chamber 18. The tubular member 15 extends outwardly through the end 3 of the cylinder in the manner shown in Fig. 1 and also extends through a center opening in the drum 17 from which it is separated by an imperforate wall while the inner end of tubular member 15 is in communication with the chamber 18 of the header 16. A plurality of flues 19 connect the two headers in the manner shown. Header 17 is provided with two bosses 20, that extend outwardly through the plate 3a and to the outer ends of which the pipes 21 are connected. These pipes connect the interior of manifold 17 with chambers "C" and "D" in the manner indicated in Fig. 3. The outer end of the tubular combustion chamber 15, instead of extending out past the plate 3a, preferably

terminates inside of the center hub 22 of manifold 17 and the hub extends outwardly beyond plate 3 in the manner shown in Fig. 6. The inner surface of hub 22 is threaded as indicated at 23 for the reception of the threaded flange 24 of the burner. This burner consists of a tubular member 25 which is integral with the flange 24 and which extends to both sides of the latter. The inner end of the burner has been indicated by reference numeral 26 and this is provided on its inner surface with a plurality of plates 27 that are secured to it and extend inwardly and are spirally arranged so that they will impart a rotary motion to any air that passes inwardly through the burner. The outer end of the burner has been provided with a plurality of similar plates 27a. A globe or other type of valve 28 is secured to the outer end of the burner and this controls the flow of compressed air. The source of this air has not been shown, as any source of air may be used. A pipe 29 extends inwardly into the interior of the burner and has secured to its inner end an L-shaped casting 30 which has a portion 31 that is located centrally with respect to the burner. This center portion 31 carries a rotatable fan 32 that is held in place by means of a perforated cap 33. When the burner is in operation, oil or other combustible fluid is introduced through the pipe 29 under pressure and emerges through the openings in cap 33, at the same time air under pressure is supplied through the valve 28 and as this rushes inwardly, it carries with it the fuel and as the mixture of air and fuel strikes the fan, the latter will start rotating, thereby assisting in completing the mixture, and if oil is employed instead of gas, the agitation caused by the fan will serve to break up the oil globules so as to produce a more complete mixture, which will be further agitated and more thoroughly mixed by the blades 27. A spark plug 34 extends through the flange 24 and serves as a means for igniting the mixture. A plug 35 is provided in flange 24 and this plug can be removed whenever it is desired to view the flame within the combustion chamber.

Let us now suppose that the burner is in operation and that the mixture of air and fuel is ignited, thereby causing a flame to project inwardly from the burner. The gases of combustion will pass through the other end of the chamber 15 and thence into the chamber 18 in the manifold 16 from which they will flow forwardly through the flues 19 and into the chamber in the manifold 17, from which they will pass through pipes 21 into the flue passages 11 and will pass through all of these in series and finally emerge through pipe 14. Located within the flue passages 11 are two pipe coils. These pipe coils have been designated by reference characters "J" and "K" in Fig. 2. The lower ends of these coils have been indicated by reference numerals 36 and 37, and these are connected by means of a pipe 38 to a common supply pipe 39, which extends to a pump or other source of oil under pressure. The flow of oil or liquid through pipe 39 is controlled by means of a valve 40. The coils "J" and "K" terminate in the upper flue passage and extend outwardly through the end plate 9, where they are connected by means of L's 41 with pipes 42, which, in turn, connect with a valve 43 which controls the flow of fluid to the pipe 44 that is located within the cylinder 1 and rests upon the bottom of the cylinder. Pipe 44 is provided with a large number of openings 45 so that any liquid or oil that enters this pipe will escape through the openings into the interior of the cylinder. As the liquid accumulates it will fill the chamber "A" and will flow through the opening at the end of plate 4 into chamber "B" and will then escape through the pipe 46, which may lead to a tank located on a wagon or to any other suitable tank where the liquid is to be stored. If the heater is used for heating water for the purpose of heating a building, the hot water that issues through pipe 46 will of course be returned to pipe 39, after it is circulated through the heating system, but if the apparatus is used for heating heavy oils for road work, the pipe 46 extends to a suitable location for discharging the heated oil into tanks by means of which the oil is transported.

It will now be seen that the hot gases or products of combustion will travel downwardly through the flue passages in the manner indicated by arrows in Fig. 1 and at the same time the oil or other liquid will pass through the pipe coils "J" and "K" in a direction opposite to that of the flue gases. The long distance in which the flue gases are in contact with the pipes containing the fluid will give ample opportunity for the heat of the gases to be transferred to the oil and as the temperature of the flue gases decreases, the temperature of the oil will also decrease and therefore the temperature gradient will remain substantially constant so as to effect a very efficient heat transfer between the gases and the oil or liquid to be heated. After the oil has been delivered to the interior of cylinder 1 by means of pipe 44, it will pass upwardly between the several flues 19 and surround the combustion chamber 15 and will therefore be subjected to the action of metal plates heated to a very high temperature. The passage of the liquid through chamber "B" further assures that there will be no appreciable escape of heat upwardly through this heater. When this heater is used in cold climates, it is, of course, desirable to have it encased in a brick structure or covered with some heat insulating material, which has not been shown but has been

indicated in Fig. 1 by reference numeral 47.

It has been found that by means of the apparatus shown on the drawings and described herein very great efficiency is obtained and that heavy oils can be very readily heated to any temperature desired with a smaller amount of fuel than ordinarily required for this purpose. Although it is customary to employ oil for fuel, it is, of course, possible to employ gases in lieu of the oils and this invention is therefore not limited to the specific nature of the fuel employed. As this apparatus is comparatively small, it can be built either as a stationary apparatus in which case it may be enclosed in brick work or may even be mounted on wheels so that it can be readily transported to whatever location is desired.

Particular attention is called to the fact that by means of this apparatus the hot gases of combustion always travel towards the place where the liquid is introduced and therefore the temperature of the liquid with which the pipes are in contact at any part of the passage decreases in somewhat the same proportion as the temperature of the flue gases and this results in a more thorough transfer of the heat than if the heat transfer were effected in any other manner.

Having described the invention what I claim as new is:

1. A device for heating liquids comprising, in combination, a cylindrical member closed at both ends, a tubular member extending through one end of the cylindrical member and terminating within the latter adjacent the other end, two drum-like headers located within the cylindrical member, one of said headers having an opening through which the tubular member passes, the second header being secured to the end of the tubular member with its interior in communication with the interior of the latter, means carried by the cylindrical member for slidably supporting the second header, a plurality of flues connecting the interiors of the headers with each other, a fuel burner secured to the end of the tubular member that is on the outside of the cylinder, a heating chamber secured to the underside of the cylinder, said chamber being divided by a plurality of spaced parallel horizontal plates into a plurality of wide narrow flue passages, each of which is in communication at one end with the flue directly above and at the other end with the flue below, the uppermost flue passage being in communication with the interior of the header nearest the fuel burner, the lowermost flue passage being in communication with the atmosphere so that the gaseous products of combustion may flow from the interior of the tubular member into one of the headers, thence through the flues to the other header and from thence through the flue passages to the atmosphere and means for conducting a

fluid from the outside of the heater to the interior of the cylinder, said means comprising pipes extending through the flue passages.

2. A device for heating liquids comprising, in combination, a cylindrical member closed at both ends, a tubular member extending through one end of the cylindrical member and terminating within the latter adjacent the other end, two drum-like headers located within the cylindrical member, one of said headers having an opening through which the tubular member passes, the second header secured to the end of the tubular member with its interior in communication with the interior of the latter, a plurality of flues connecting the interiors of the headers with each other, the second header being attached to the tubular member and to the flues only whereby the parts can expand relative to the cylindrical member without setting up strains, a heating chamber secured to the underside of the cylinder, said chamber being divided by a plurality of spaced parallel horizontal plates into a plurality of wide narrow flue passages, each of which is in communication at one end with the flue directly above and at the other end with the flue below, the uppermost flue passage being in communication with the interior of the header through which the tubular member passes, the lowermost flue passage being in communication with the atmosphere so that the gaseous products of combustion may flow from the interior of the tubular member into one of the headers thence through the flues to the other header and from thence through the flue passages to the atmosphere and means for conducting a fluid from the outside of the heater to the interior of the cylinder, said means comprising pipes extending through the flue passages, the interior of the cylinder being separated into two chambers by a horizontal plate lying to one side of the center, the two compartments being connected at one end.

3. A structure of the class described comprising a cylindrical member, a casing into the top of which the said member is set, a heating element located in the said member and comprising a tubular combustion chamber and comprising two spaced hollow headers connected by the combustion chamber and with one of which the chamber communicates at one end and through the other of which and the adjacent wall of the casing, the other end of the combustion chamber passes, and open-ended pipes surrounding the combustion chamber and in communication at their extremities with the respective headers; the header with which the tubular member communicates being movable with respect to the cylindrical member whereby the combustion chamber and flues can expand independently of the cylindrical member, spaced superimposed

- horizontal plates located in the casing below the cylindrical member and forming flues intercommunicating at alternate ends, the uppermost flue communicating with one of the headers of the heating element, and the lowermost flue with the atmosphere, a pipe manifold extending longitudinally and successively through the various flues and in communication at its lower end with a source of liquid supply, and at its upper end with the interior of the cylindrical member that surrounds the heating element, the last named member having an outlet at the top for the said liquid.
4. A liquid heater comprising a casing open at the top and having semi-circular end openings, a cylindrical member set into the top of and closing the chamber of said casing, a furnace element located in the cylindrical member and comprising a tubular combustion chamber extending lengthwise of said member, two spaced vertically disposed headers with one of which the combustion chamber communicates at one end and through the other of which and the adjacent wall of the casing, the said chamber passes, the header with which the combustion chamber communicates being movable with respect to the cylindrical member whereby the combustion chamber and flues can expand and contract at a different rate than the cylindrical member without producing excessive strains, and a set of tubes disposed around the combustion chamber and in communication at their ends with the respective headers; spaced, superimposed, horizontally disposed plates located in the casing below the cylindrical member, said plates being interrupted at alternate ends to form intercommunicating flues the uppermost of which is in communication at one end with the casing chamber below the cylindrical member, and the lowermost of which is in communication with the atmosphere, a conduit connecting the casing chamber below the cylindrical member with the header through which the combustion chamber passes, a pipe manifold for passing liquid through the said flues, said manifold being in communication at its lower end with a source of liquid supply, and a perforated pipe located in the cylindrical member with which the upper end of the said manifold is connected, the said member also having an opening at the top for the escape of said liquid.
5. In combination, apparatus for heating liquid comprising a casing, a cylindrical member set into the casing and closing the chamber of the latter, a furnace element located in the said member and comprising two vertically disposed spaced headers, a tubular combustion chamber in communication at one end with one header and passing through the other header and the adjacent wall of the casing, and open-ended flues connecting and communicating with the respective headers, the header with which the combustion chamber communicates being movable with respect to the cylindrical member whereby the combustion chamber and flues can expand and contract at a different rate than the cylindrical member without setting up severe strains; means for supplying the combustion chamber with fuel at its exposed end, means for conducting the products of combustion from one of the headers to the casing chamber below the cylindrical member, a pipe manifold located in the said portion of the casing chamber and in communication at its lower end with a source of liquid supply and at its upper end with the chamber of the cylindrical member, the last named chamber having a partition above the furnace element dividing it into upper and lower compartments which are in communication at one end of the partition, the uppermost compartment being open at the top for the escape of the heated liquid.
- In testimony whereof I affix my signature.  
WILLIAM A. J. KREAGER.

70

75

80

85

90

95

100

105

110

115

120

125

130