

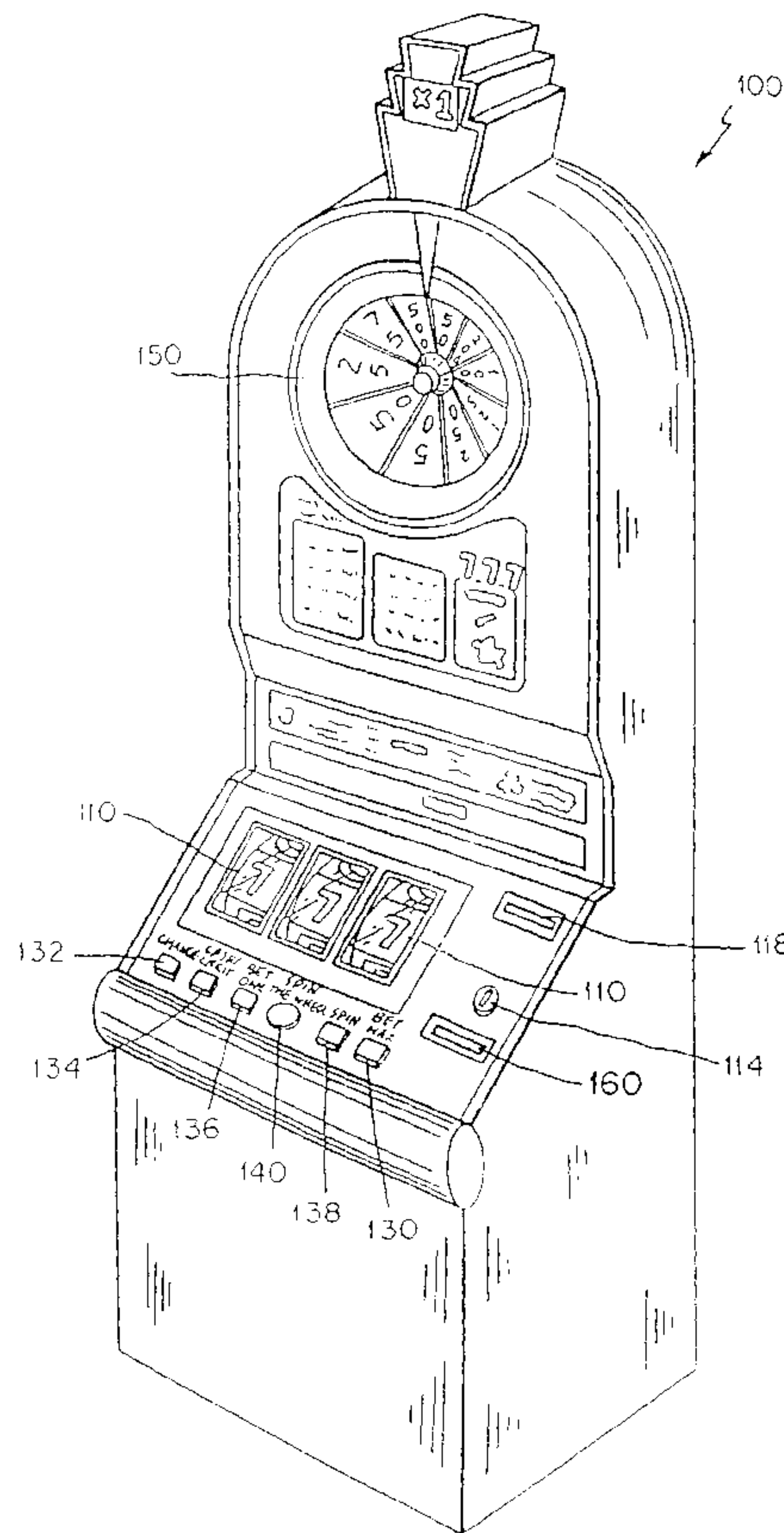

(86) Date de dépôt PCT/PCT Filing Date: 2001/09/05
 (87) Date publication PCT/PCT Publication Date: 2002/03/14
 (85) Entrée phase nationale/National Entry: 2003/03/03
 (86) N° demande PCT/PCT Application No.: US 2001/027507
 (87) N° publication PCT/PCT Publication No.: 2002/021468
 (30) Priorité/Priority: 2000/09/05 (09/655,252) US

(51) Cl.Int.⁷/Int.Cl.⁷ G07F 17/32
 (71) Demandeur/Applicant:
ANCHOR GAMING, US
 (72) Inventeurs/Inventors:
CANNON, LEE E., US;
MARONEY, MIKE, US;
GUINN, ROBERT, US;
ROEMER, MICK D., US;
ADAMS, WILLIAM R., US;
DEGRANDMAISON, JASON, US
 (74) Agent: SMART & BIGGAR

(54) Titre : PROCEDES ET APPAREILS DE DISTRIBUTION DE TICKETS VIA DES DISPOSITIFS DE JEU ET DES TERMINAUX DE LOTERIE
 (54) Title: METHODS AND APPARATUS FOR PROVIDING TICKETS FROM GAMING DEVICES AND/OR LOTTERY TERMINALS



(57) **Abrégé/Abstract:**

Gaming devices dispense tickets which are unrelated to a player's success on a particular game played on a gaming device or to the player's credits on a credit meter or other "cash out" indicator. The gaming devices provide gaming awards, and also

(57) **Abrégé(suite)/Abstract(continued):**

provide tickets. Other methods provide tickets during the play of wagering games. Still other embodiments comprise lottery terminals which dispense tickets other than those purchased by a lottery patron or won on a purchased lottery ticket.

(12) INTERNATIONAL APPLICATION PUBLISHED UNDER THE PATENT COOPERATION TREATY (PCT)

(19) World Intellectual Property Organization
International Bureau(43) International Publication Date
14 March 2002 (14.03.2002)

PCT

(10) International Publication Number
WO 02/21468 A2(51) International Patent Classification⁷: G07F 17/32

(21) International Application Number: PCT/US01/27507

(22) International Filing Date:
5 September 2001 (05.09.2001)

(25) Filing Language: English

(26) Publication Language: English

(30) Priority Data:
09/655,252 5 September 2000 (05.09.2000) US

(71) Applicant: ANCHOR GAMING [US/US]; 815 Pilot Road, Suite G, Las Vegas, NV 89119 (US).

(72) Inventors: CANNON, Lee, E.; 3550 Stucky Road, Bozeman, MT 59715 (US). MARONEY, Mike; 102 Erik Drive, Bozeman, MT 59715 (US). GUINN, Robert; 3052 Via Venezia, Henderson, NV 89052 (US). ROEMER,

Mick, D.; 31 Bridal Falls Court, Las Vegas, NV 89148 (US). ADAMS, William, R.; 5870 Darby, Las Vegas, NV 89146 (US). DEGRANDMAISON, Jason; 46 South LeClercde Place, Atlantic City, NJ 08401 (US).

(74) Agents: WALKOWSKI, Joseph, A. et al.; Traskbritt, 230 South 500 East, Suite 300, P.O. Box 2550, Salt Lake City, UT 84110 (US).

(81) Designated States (*national*): AE, AG, AL, AM, AT, AU, AZ, BA, BB, BG, BR, BY, BZ, CA, CH, CN, CO, CR, CU, CZ, DE, DK, DM, DZ, EC, EE, ES, FI, GB, GD, GE, GH, GM, HR, HU, ID, IL, IN, IS, JP, KE, KG, KP, KR, KZ, LC, LK, LR, LS, LT, LU, LV, MA, MD, MG, MK, MN, MW, MX, MZ, NO, NZ, PL, PT, RO, RU, SD, SE, SG, SI, SK, SL, TJ, TM, TR, TT, TZ, UA, UG, UZ, VN, YU, ZA, ZW.(84) Designated States (*regional*): ARIPO patent (GH, GM, KE, LS, MW, MZ, SD, SL, SZ, TZ, UG, ZW), Eurasian patent (AM, AZ, BY, KG, KZ, MD, RU, TJ, TM), European

[Continued on next page]

(54) Title: METHODS AND APPARATUS FOR PROVIDING TICKETS FROM GAMING DEVICES AND/OR LOTTERY TERMINALS

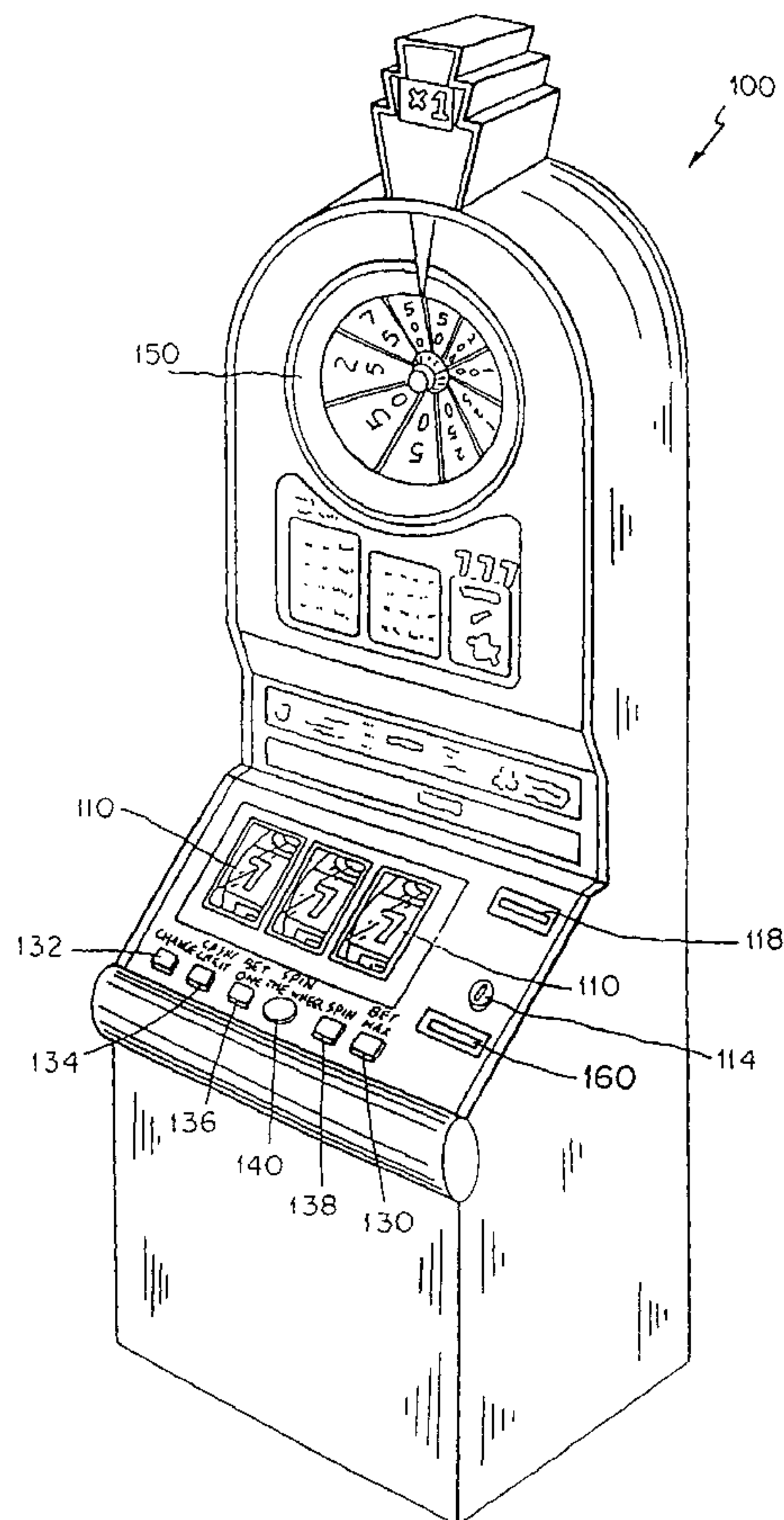

(57) Abstract: Gaming devices dispense tickets which are unrelated to a player's success on a particular game played on a gaming device or to the player's credits on a credit meter or other "cash out" indicator. The gaming devices provide gaming awards, and also provide tickets. Other methods provide tickets during the play of wagering games. Still other embodiments comprise lottery terminals which dispense tickets other than those purchased by a lottery patron or won on a purchased lottery ticket.

WO 02/21468 A2

WO 02/21468 A2



patent (AT, BE, CH, CY, DE, DK, ES, FI, FR, GB, GR, IE, IT, LU, MC, NL, PT, SE, TR), OAPI patent (BF, BJ, CF, CG, CI, CM, GA, GN, GQ, GW, ML, MR, NE, SN, TD, TG).

For two-letter codes and other abbreviations, refer to the "Guidance Notes on Codes and Abbreviations" appearing at the beginning of each regular issue of the PCT Gazette.

Published:

— *without international search report and to be republished upon receipt of that report*

METHODS AND APPARATUS FOR PROVIDING TICKETS FROM GAMING DEVICES AND/OR LOTTERY TERMINALS

5 The present invention relates to methods and apparatus for providing tickets from games of chance, such as gaming devices and from lottery terminals.

TECHNICAL FIELD

10 Gaming devices have been known which dispense winning awards in various forms. For example, it has been known to dispense winning prizes if a randomly determined outcome is one of a preselected plurality of winning outcomes from a greater plurality of possible outcomes. Such awards have been provided to players in the form of coins, currency, credits or tickets redeemable for prizes.

15 The assignee of the present invention owns U.S. Patent No. 5,397,125 entitled GAMING DEVICE WITH PAYOUTS OF MULTIPLE FORMS wherein winning players are provided with the opportunity of receiving payouts in at least two distinct forms, both of which are inherently valuable. For example, according to one embodiment, a first payout comprises a national currency while another form of payout comprises tokens formed of a precious metal such as silver or gold. It has also been
20 previously disclosed to dispense winning payouts consisting of either checks in a form redeemable at a bank or other "redeemable tickets," i.e., tickets which are redeemable for prizes at a gaming establishment.

25 It is believed that all of the prior art which dispenses various forms of awards provided those awards only if a player has won a game on the gaming device.

DISCLOSURE OF INVENTION

30 The present invention comprises various embodiments of gaming devices which dispense tickets which are supplemental to, unrelated to, and/or other than the gaming award. As used herein, the term "gaming award" is used to indicate an award provided to a player based upon the outcome of a game played on a gaming device or table game which is determined, at least in part, by some randomly determined gaming event. The gaming devices of the present invention provide gaming awards, typically in a form selected from the group consisting of coins, currency, credits or "redeemable tickets," in

-2-

response to a randomly determined event, and also provide supplemental and/or unrelated other "tickets". As used herein, the term "tickets" is used broadly to indicate printed and/or electronically encoded matter which may not have any inherent value such as an advertisement or announcement; however, it may be redeemable for services, 5 currency, discounts or other goods of value. The tickets of the present invention are actually dispensed, that is, some physical form is actually provided to a player. Additionally, according to some embodiments of the present invention, the tickets are actually printed, either in whole or in part, at the gaming device. The ticket dispensers and/or printers can be located internal to the housing of the gaming device or on the 10 exterior of the gaming device. As used herein, the term "coins" includes national currency and tokens, whether formed of a precious metal or some other material. The term "gaming establishment" includes casinos and other places where gaming is conducted.

According to some embodiments of the present invention, gaming devices are 15 provided which randomly determine some outcome and then provide a gaming award when preselected winning outcomes are determined, and also comprise means for dispensing tickets independently of those preselected winning outcomes. For example, a gaming device is provided with a random number generator which is used to randomly determine the outcome, e.g., final reel display on a reel slot machine, but the tickets are 20 dispensed independently of the particular outcome. The random number generator or other random event determining device is typically located within the housing of a gaming device; however, in the case of distributed gaming, one or more random number generators may be located in a host computer which is linked to a plurality of gaming terminals.

25 According to still further embodiments, tickets are dispensed according to criteria which include one or more particular outcomes of a random event determining device.

The dispensing and/or printing of the tickets can also be effected by criteria other than the random event determining device, for example, only at various times or 30 depending upon some other criteria, such as rate of play, length of play, or amount wagered, and/or may be in addition to one or more particular gaming awards.

-3-

Still further embodiments of the present invention comprise at least one random number generator for determining the outcome of a wagering game and a different random number generator for controlling one or more aspects of the dispensing of tickets. In this case, either random number generator can be located within the housing
5 of the gaming device or at some remote location which is linked to the gaming device.

Other embodiments of the present invention relate to methods of conducting games of chance wherein tickets to a future drawing are provided. As used herein, the term "drawing" is meant broadly to include lotteries, sweepstakes, and other random selections, wherein one or more winning indicia are randomly selected from a plurality
10 of such indicia. Other methods comprise providing tickets for play on that game or another game in conjunction with the tickets to a drawing.

Other embodiments of the present invention comprise methods of conducting wagering games comprising dispensing tickets which are redeemable for credits in a future game only after a predetermined period of time.

15 Other embodiments of the present invention comprise lottery terminals which dispense tickets other than the purchased tickets and based on criteria unrelated to the lottery patron's success from a purchased ticket.

These and other embodiments are described below.

20 BRIEF DESCRIPTION OF THE DRAWINGS

FIG. 1 illustrates one embodiment of the present invention on a reel slot machine.

FIG. 2 illustrates a second embodiment of the present invention on a video slot machine.

25 FIG. 3 illustrates another embodiment of the present invention on a reel slot machine.

FIG. 4 illustrates an embodiment of the present invention on a table game.

FIG. 5 illustrates a plurality of gaming devices linked to a host controller.

30 FIG. 6 illustrates an embodiment of the present invention on a lottery terminal.

-4-

BEST MODE OR MODES FOR CARRYING OUT THE INVENTION

Some embodiments of the present invention relate to gaming devices comprising ticket dispensers which dispense tickets in addition to and/or independent of the gaming award typically provided by the gaming device when a winning outcome is randomly selected from a plurality of possible outcomes. Other embodiments dispense tickets based on criteria unrelated to a randomly selected outcome.

One preferred embodiment of the present invention is illustrated in FIG. 1 wherein a gaming device 100 comprises a primary gaming unit in the form of a standard 3-reel slot machine with display reels 110 and a secondary or bonus event in the form of a wheel 150. Suitable controls and currency mechanisms including a coin slot 114, bill validator 118, and ticket dispenser 160 are provided. Furthermore, suitable player controls including CHANGE button 132, CASH/CREDIT button 134, BET ONE button 136, SPIN button 138, SPIN THE WHEEL button 140 and BET MAX button 130 are also provided.

In a similar video-display gaming device 200 illustrated in FIG. 2, the primary reels are illustrated on a video display 210 and a secondary event in the form of a video display of a rotatable reel 250 is provided. Furthermore, the outcome of the secondary gaming unit can be increased by a multiplier 270. In a manner similar to the embodiment illustrated in FIG. 1, suitable controls and currency mechanisms including a coin slot 214, bill validator 218, and a payout chute 220 are provided. Furthermore, suitable player controls including CHANGE button 232, CASH/CREDIT button 234, BET ONE button 236, SPIN button 238, SPIN THE WHEEL button 240 and BET MAX button 230 are also provided. Additionally, an external ticket dispenser 260 is provided. As indicated in these figures, the supplemental ticket dispenser can be, but is not necessarily, separate and distinct from the portion of the gaming device which provides the gaming awards.

A still further embodiment 300 of the present invention is shown in FIG. 3 wherein a ticket dispenser 360 is provided separately from a payout chute 320 which provides at least some of the gaming awards. In video-display gaming device 300 illustrated in FIG. 3, the primary reels are illustrated on a video display 310 and a secondary event in the form of a video display of a rotatable reel 350 is provided. Furthermore, the outcome of the secondary gaming unit can be increased by a multiplier

-5-

370. In a manner similar to the embodiment illustrated in FIG. 2, suitable controls and currency mechanisms including a coin slot 314, bill validator 318, and a payout chute 320 are provided. Furthermore, suitable player controls including CHANGE button 332, CASH/CREDIT button 334, BET ONE button 336, SPIN button 338, SPIN THE
5 WHEEL button 340 and BET MAX button 330 are also provided.

One preferred embodiment of the present invention comprises a gaming device which is coinless, i.e., which does not dispense coins. Instead, the gaming device prints a cash voucher of the credit balance when a player cashes out. The tickets of this embodiment of the present invention are preferably and advantageously printed by the
10 same printer that prints the cash vouchers. Those skilled in the art will appreciate that gaming awards are typically provided or indicated in the form of coins, currency, credits or redeemable tickets in response to a randomly determined outcome by the gaming device.

According to another embodiment of the present invention, a gaming device is
15 provided with a ticket dispenser which dispenses advertisements. For example, advertisements for a product or service unrelated to the gaming establishment can be provided. Additionally, either goods or services typically provided by the gaming establishment can be advertised or the ticket can be in the form of a coupon redeemable for such goods or services, such as free meals, a free room, a show, or credits on the
20 gaming device which dispensed the ticket, or credits on another game. The credits can be real credits or promotional credits, wherein real credits can be cashed out for cash while promotional credits can only be used to play a game and cannot be cashed out. From the present description, those skilled in the art will appreciate that the ticket dispensers of the present invention can be utilized to introduce players to new games at
25 the gaming establishment.

One embodiment of the present invention dispenses tickets in response to signals generated by the gaming establishment and/or to one or more signals input at a remote location such as at a control booth. For example, a gaming establishment or other game operator can program a host computer to dispense tickets automatically, with direct
30 operator input or with indirect operator input. In the case of tickets dispensed automatically, a system is set up and tickets are subsequently dispensed without further operator input. In instances of tickets being dispensed with direct operator input, a

-6-

specific signal is sent by an operator to a specific gaming device at a specific time. In the case of tickets dispensed with indirect operator input, after an operator provides input, for example, at a host computer, some device performs some function which affects the identity of the ticket recipient, the timing that the ticket is dispensed, and/or the award or promotion reflected on the dispensed ticket. For example, a casino operator can decide to issue a prize, such as a television set, and make an announcement which is broadcast throughout the casino. The announcement can give patrons a time in which a voucher for that prize will be dispensed from certain gaming devices. The dispensing of tickets can be limited to a certain subset of gaming devices or by other criteria determined by the gaming establishment. At the predetermined time, a casino operator then issues the voucher for the prize according to the predetermined criteria.

As shown in FIG. 5, a plurality of gaming devices 510 can be linked to a host computer-operated controller 520. In this manner, the dispensing of tickets in one or more of the manners described herein can be controlled and/or monitored by a host device 520 which is linked to a plurality of gaming devices.

According to another embodiment of the present invention, the ticket dispenser of the present invention will dispense tickets randomly throughout the day. According to one preferred embodiment, the random dispensing of tickets can require that the specific gaming device is being played; however, according to still another embodiment of the present invention, tickets are dispensed randomly throughout the day even if the particular gaming device from which the ticket is dispensed is not being played at that time.

According to still another embodiment of the present invention, tickets can be dispensed depending upon the outcome of another gaming device. For example, gaming devices within a certain area, such as those in close proximity to a first gaming device will dispense tickets if that first gaming device displays at least one of a plurality of possible outcomes. For example, if one gaming device provides a substantial prize, surrounding gaming devices can dispense consolation tickets, thereby adding to and expanding the merriment and excitement in that particular area of the gaming establishment.

According to another embodiment of the present invention, tickets will only be dispensed if the gaming device containing the ticket dispenser is being played at a certain

-7-

minimum rate of play, e.g., four plays per minute. Thus, the rate of play can be a threshold criteria above which the player must play to qualify for a ticket, while the actual dispensing of the ticket will depend on another criteria, such as a timer, a random number generator, etc.

5 According to another embodiment of the present invention, tickets are only dispensed if a player has placed a player tracking card in the gaming device. The ticket dispensed in accordance with one preferred embodiment of the present invention is supplemental to any value previously associated with a player tracking card.

10 As noted above, the tickets can be promotional tickets which do not have any inherent or redeemable value other than to provide information relating to a product or service which is available either at the gaming establishment or elsewhere. Preferably, however, the tickets are redeemable for some product or service. For example, the ticket can be redeemable for credit(s) on the gaming device from which it was dispensed or at some other game(s). Additionally, the tickets can be redeemable for services
15 provided by the gaming establishment. Furthermore, the tickets can be in the form of scratch-off tickets which when scratched off can provide monetary prizes, goods or services.

 According to one preferred embodiment of the present invention, a gaming device prints a ticket which provides eligibility for a drawing as well as at least one free
20 play after a predetermined time period. If the drawing is run with one or more numbers, the numbers can be chosen by the gaming device, by a host computer, or by a player through input controls such as a keypad or touch screen at the gaming device. The drawing can be conducted by the gaming establishment, by entry into a traditional government-run lottery, or through a third party drawing. Entry to the drawing can be
25 exclusively via the gaming devices or may also be permitted by individuals through the purchase of drawing tickets, as in the case of a traditional government lottery.

 According to this embodiment of the present invention, the ticket is preferably coded, for example, with a secure random number which serves as entry into a drawing. For example, the drawing can be conducted by one or more gaming establishments at
30 predetermined times, e.g., monthly. The dispensed ticket also advantageously provides a player with one or more credits on the gaming device which dispensed the ticket, on some other gaming device(s), or on a number of predetermined gaming devices.

-8-

Advantageously, the drawing feature and the ability to obtain game credits utilizing one of these dispensed tickets only becomes valid after a predetermined time period. For example, a gaming device may dispense tickets during one particular week which provides a player with game credits or at some future time and eligibility in a drawing which is conducted at a different future time. Alternatively, the future game credits and the drawing eligibility can be at the same time. Therefore, the patron can return to the games which incorporate this feature some predetermined time after the ticket was dispensed, insert the ticket into the gaming device and receive notification of his/her status regarding the drawing as well as credits on the gaming device for one or more free plays. Awards won from one of the disclosed drawings can be paid directly to the player or can be issued as credits to the gaming machine, or some combination, for example, lower tier awards provided at the gaming device while higher tier cash prizes only pay directly to a player. This embodiment of the present invention encourages return play and customer loyalty and provides a player with at least one additional chance of winning even after the player ends his or her current play session. This embodiment of the present invention also permits a gaming establishment to offer a relatively large, lottery-styled jackpot to a player. The manner in which a player is notified of the drawing outcome can be accomplished visually, audibly, with a gaming device on a leader board, or at some location remote from the gaming device, but most preferably within a participating gaming establishment. The drawing status indication is most preferably provided to the player on the gaming device which also offers the player one or more free plays. In this manner, a player can be introduced to new gaming devices. The tickets of this embodiment of the present invention can also be provided with an expiration. Thereby, a player may be provided with a specific time window for obtaining entry into the drawing or for free play credit.

According to this preferred embodiment of the present invention, a player may not be guaranteed that the winning numbers drawn for any specific period will produce a winner from the group of tickets dispensed for that particular drawing. If there is no winner, the jackpot preferably rolls over into a subsequent drawing. For example, if the drawing is determined by randomly selecting a single number from the numbers 1-10,000 for a drawing during the first week of September, yet only 1,500 tickets are dispensed containing entries to this particular drawing, then the winning number may not

-9-

have been dispensed and the drawing will either end without a winner and/or the jackpot will be rolled over into the subsequent drawing, for example, a drawing during the second week of September. The tickets of the present invention will also preferably have a printed time period during which a winning drawing ticket must be redeemed.

5 For example, for a drawing during the first week of September, a player may be required to redeem a winning ticket during the month of September. Any other time periods can be set as desired.

It is also within the scope of this aspect of the present invention to provide a player with game credits on a gaming device at the same times, different times, or
10 overlapping times as the drawing feature. For example, for a drawing during the first week of September, a player can be provided with game credits on specified gaming devices during the first two weeks of September or during any time during the months of September or October or, alternatively, only during the month of October. In the latter case, a player is encouraged to return to the particular gaming establishment
15 during September to determine the players status with respect to the drawing and again in October to receive free plays on the gaming device. Most preferably, the game credits become valid after the drawing in order to encourage a player to return to a gaming device. The free plays may simply be some number of credits which are either real or promotional. In the case of real credits, a player can cash out the credits for
20 money while promotional credits may only be used for play on a gaming device and cannot be cashed out.

When the ticket provides credits on a gaming device, either the same gaming device which dispensed the ticket or a different gaming device, the gaming device on which the free credits are provided preferably comprises an electronic reader for reading
25 the ticket. In this manner, a player can simply go to the gaming device at a valid time and insert the ticket to play a game.

According to this embodiment of the present invention, a gaming device is provided with suitable printers, controls and communication software in order to permit the desired control, monitoring and validation of dispensed tickets by the gaming
30 establishment or other entity responsible for the supervision and/or control of the tickets. One preferred ticket of this embodiment of the present invention will include information indicating the valid time window for the free play credit and a number or

-10-

numbers associated with a valid entry into the drawing and may also include promotional descriptions, disclaimers, expiration date, issue date, machine number, location identifier, and a bar code for validation purposes.

5 A somewhat simpler embodiment of the present invention comprises a gaming device and method for playing a game wherein the gaming device dispenses a drawing ticket comprising one or more sets of numbers or other indicia. According to this embodiment of the present invention, a drawing is held periodically and prizes are awarded to players holding winning tickets. The top prize of the drawing may be a fixed prize or a progressive prize based upon the total amounts wagered on participating
10 gaming devices. This feature can also have time limits such as those discussed with other embodiments.

While various preferred embodiments of the present invention comprise dispensing tickets from gaming devices such as reel slot machines and video gaming devices, according to other embodiments of the present invention, tickets for drawings,
15 game credits or free plays are dispensed during the play of wagering games commonly played on tables such as table card games, dice games, roulette, baccarat, etc. According to these embodiments of the present invention, the tickets can provide free credits or free plays on the game at which the ticket is dispensed or at some other game, most preferably only becoming valid after some predetermined period of time.
20 Alternatively and/or additionally, these tickets provide eligibility for a drawing.

Another embodiment of the present invention illustrated in FIG. 4 comprises a gaming table 400 which is provided with a playing surface 410, chip rack 420, card shoe 430 and discard tray 440. A plurality of player stations is located around the playing surface. While six stations are illustrated, it is within the scope of the present invention
25 to provide more or fewer player stations. According to this embodiment of the present invention, each playing area comprises a wager area 450, a card area 460 and a ticket dispenser 470. According to this embodiment of the present invention, a ticket is dispensed at times or in manners described in accordance with the other embodiments.

According to a still further embodiment of the present invention, a gaming
30 device issues a ticket which is not itself a drawing ticket but which is redeemable for a drawing ticket. According to this embodiment of the present invention, a player takes the dispensed ticket to either a booth wherein personnel issue the drawing ticket or to a

-11-

central ticket dispenser which is capable of reading the ticket dispensed from the gaming device, confirming that the dispensed ticket is valid and then issuing a drawing ticket to the player.

Thus, some embodiments of the present invention comprise providing tickets
5 valid for free play, real credits or promotional credits on a gaming device after some predetermined period of time. As used herein, when a ticket is said to be redeemable or valid only "after some predetermined period of time," that length of time can be fixed in terms of hours, days, weeks, etc. or can simply be the length of time from the dispensing of the ticket to some future time or future event, e.g., a drawing. The free play or
10 credits can be useful on the same gaming device which dispensed the tickets or at some other gaming device for promotional purposes, such as a new game which has recently been introduced.

All gaming devices and methods of the present invention can be used with coin games or with coinless games. In addition to the criteria above, the tickets of the
15 present invention can also be dispensed after the play of a certain number of games on a particular gaming device. This feature can encourage players to continue playing, particularly if the number of players required in order to receive a free ticket is displayed to the player. Thus, tickets can be dispensed based upon the number of games played, the cash amount played, or some other similar play amount measurement. The tickets
20 can also be dispensed by criteria which is time based, i.e., based upon the player's rate of play, or simply based on the cumulative time that a player has played. The present invention, therefore, is particularly attractive to gaming establishments which do not have an existing player tracking system since embodiments of the present invention can be implemented where a single gaming device itself tracks and rewards a qualified
25 amount of play by a player.

According to another aspect of the present invention, a periodic random promotion by a gaming establishment can utilize tickets dispensed at a gaming device. According to this embodiment of the present invention, a player can receive tickets for a random promotion if the player meets certain play criteria, for example, wagering a
30 predetermined amount during a certain period of time before the random promotion drawing. For example, if a player wagers twenty dollars, the player can receive a number for a monthly drawing. By the time of the monthly drawing, a player can accumulate

-12-

many tickets. This aspect of the present invention provides an easy way for a gaming establishment to dispense tickets while insuring that a player has met threshold criteria to qualify for the random promotion. The embodiments of the present invention which dispense drawing tickets are preferably of the quick-pick type, wherein the computer
5 picks the numbers. However, it is also within the scope of the present invention to provide a player with the ability to select his or her own numbers utilizing controls at the gaming device, for example, a touch screen number selector or a key pad.

All gaming devices of the present invention can be provided with ticket printers, coin hoppers, or both.

10 Aspects of the present invention may or may not have a direct relation to the payout of the specific wagering game with which it is associated. As used herein, the term "gaming device" is used broadly to include all wagering games of chance, including but not limited to slot machines and table games, video games, such as video poker and video lottery gaming machines, coin games, coinless machines, and cashless machines.

15 Certain aspects of the present invention offer the advantages of significantly increasing the possible payout of a gaming device. For example, a gaming establishment can be provided with a number of nickel slot machines or other gaming devices. These gaming devices can be provided with ticket dispensers attached to or incorporated into the cabinets of the gaming devices. The ticket dispensers will dispense promotional
20 scratch-off tickets to a player based on an event or string of events that are predetermined by the casino and controlled by another peripheral device, or by the casino's slot accounting/player tracking system. Some tickets may be redeemable for promotional items such as show tickets, dinners, rooms, etc., while other tickets may be valid for a large drawing such as a state lottery which provides a player with a chance to
25 win many millions of dollars. According to this aspect of the present invention, a gaming establishment would incur the expense of the promotions, as well as the expense of the drawing tickets, which is typically less than one dollar per ticket. The gaming establishment can regulate the frequency with which the tickets are dispensed and thus the associated cost of the promotion. This aspect of the present invention allows a
30 gaming establishment to offer a slot patron or other gaming device player a chance to win millions of dollars for just a single nickel bet. The denominations used are purely for illustration. From the present description, those skilled in the art will appreciate that

-13-

different prizes can be provided without departing from the scope of the present invention.

According to a still further embodiment of the present invention, a player who is playing a gaming device can query his account for comp dollars and/or comp points in real time from the gaming device. Those skilled in the art will appreciate that player tracking systems typically distinguish between “comp points” wherein a player may receive, for example, ten points for each dollar wagered and “comp dollars” which are typically provided to players from a discretionary fund dispensed by a casino and which are accumulated based on the casinos theoretical hold of a particular game. With comp dollars, a player will typically receive more comp dollars per dollar wagered when playing on a gaming device which has a relatively low theoretical payout. Typically, gaming devices only show a player’s comp points. If a player wishes to redeem comp points, the player must typically leave a gaming device and go to a club booth, which then issues a voucher for goods or services, e.g., a free dinner. In accordance with one aspect of the present invention, while a player is at a gaming device, the player can query his account in real time through the use of suitable controls. After suitable input from a player at a gaming device, which may comprise the input of a PIN number for security purposes, the gaming device will download information from a central player tracking system which provides an indication to the player at the gaming device of the player’s comp points. The player tracking system can also send information regarding particular options that a player has and indicate those options to the player right at the gaming device. Therefore, if a gaming establishment is running low on a particular award, for example, a particular jacket which is normally available to patrons with sufficient comp points, this option can be automatically removed from the option list displayed to the player on the gaming device. This embodiment of the present invention provides a labor savings for the casino and provides a more convenient method for player redemption of comp points or comp dollars. Utilizing those same controls, a player can obtain a printout of a voucher for a free meal or can have the goods, for example, the jacket, delivered to the player’s room or home address. This aspect of the present invention advantageously does not require a player to leave a gaming device in order to redeem “comp points” or “comp dollars.” According to this aspect of the present invention, a gaming device is preferably placed in a “wait” mode with a predetermined timeout

-14-

period so that the redemption of "comp points" or "comp dollars" can be completed during the short download period, preferably a matter of seconds, and internal checks can be performed to ensure that the formatting requests to the ticket are within valid ranges. Once the ticket is successfully printed, an acknowledgment can be sent back to the player tracking system of the gaming establishment so that the card reader display can be updated with the appropriate message. At the same time, the gaming device can display a message indicating to the player that the "comp" issuance has been completed. Also, if the "comp" ticket is unreadable, a jam occurs, or some other problem occurs, a recall from the game can be performed showing the ticket payout history along with the "comp" amount and the player tracking card number for the casino operator. If a "comp" redemption is requested and the game is in the middle of play, or in a state where the "comp" redemption cannot be processed, an appropriate message is preferably displayed to the player and sent back to the player tracking system of the gaming establishment indicating an appropriate error code corresponding to the gaming device's current state.

Tickets of certain embodiments of the present invention can be comp tickets which are issued when commanded by a central host computer which is connected to a plurality of gaming devices or by the gaming devices themselves. Comp tickets can be issued after a predetermined amount of wagering has been completed or if a player has played a game for a predetermined amount of time. The dispensing of comp tickets may also be dependent upon the rate of play, the amounts wagered, the number of games played, or the length of continuous game play. The comp ticket could also be awarded when a specific game outcome occurs which may or may not be related to a winning outcome on the gaming device. Alternatively, a comp ticket can be awarded if a player experiences one or more losing streaks of some predetermined length in order to perk up a losing player. Still furthermore, a compensation ticket can be provided as a result of a random outcome which is only determined after certain qualifying game play. One or more of these methods for issuing "comp" tickets can be activated at the same time. For example, according to one embodiment of the present invention, a plurality of different methods for awarding "comp" tickets can be active and configured into a single gaming device. The particular award which is provided with a specific "comp" ticket can be determined separately with each of the criteria for awarding the "comp" ticket.

-15-

Therefore, while a “comp” ticket can be awarded for one particular criteria, that ticket may have a different award value than a “comp” ticket awarded in response to a different “comp” ticket issuance criteria. Each “comp” ticket preferably comprises an identifying number, a textual description of the “comp” awarded, and textual instructions as to how to redeem the “comp” ticket. If a “comp” ticket is displayed on a gaming device, the description preferably displays only the “comp” award and not the instructions. However, the “comp” ticket itself is preferably printed with the redemption instructions and the identifying number along with the description of the particular “comp” award.

10 According to the following example, if the “comp” ticket is to be awarded in response to accumulated play, a particular game outcome, a losing streak, or a random outcome for a particular qualifying game event, then the particular value of the “comp” ticket may determine when a “comp” ticket is awardable. On the other hand, the value of the particular “comp” ticket would not determine if the “comp” ticket is awardable for “comp” tickets issued by a host computer. In order to monitor the accumulation of “comp” points, a gaming device is preferably configured such that each of the “comp” criteria which can result in the dispensing of a “comp” ticket is provided with a meter which accumulates amounts earned towards a “comp” award. If the meter reaches the value of the associated “comp”, the “comp” becomes awardable. Except for “comps” issued by a host computer, each meter will be incremented by some amount if certain specific conditions are met following each qualifying game played. A qualifying game, for example, is preferably one that meets the minimum bet requirements for a particular “comp” criteria. The minimum bet requirements can be specified either as a specific cash value or as requiring a MAX BET on the game. For each “comp” criteria, an increment size can be defined which determines the growth rate of the “comp” meter.

EXAMPLE

The following is an example of one method of issuing “comp” tickets according to different criteria which are described herein as “comp-type 0” through “comp-type 4” which are generally described as:

- “Comp-type 0” - HOST TRIGGERED
- “Comp-type 1” - ACCUMULATED PLAY
- “Comp-type 2” - GAME TRIGGERED

-16-

“Comp-type 3” - LOSING STREAK

“Comp-type 4” - RANDOM OUTCOME

In the case of “comp- type 0” - HOST TRIGGERED, the gaming establishment
5 or other game operator designates which “comp” to award and specifies whether a
ticket is issued from a gaming device immediately or after the next game is played. The
casino controls will specify whether the command to issue a “comp” ticket should be
ignored if the gaming device shows zero credits or whether the “comp” award should be
queued up until there is a credit balance.

10 The issuance of “comp” awards according to “comp-type 1” -
ACCUMULATED PLAY provides a wide variety of tracking ability. In this example,
time is broken up into periods of specified length. Internal metering is done on either
the number of games played or on the amount wagered during a specific time period.
To determine whether play is at a sufficient rate, a threshold is specified. If the metered
15 amount for a prior period meets or exceeds the threshold, then the play rate is
considered to be sufficient. For this “comp-type 1” an accumulation meter can be
incremented based upon the number of qualifying games played after sufficient play rate
has been achieved or upon those games that were played in the period prior to achieving
the play rate. In the former case, the accumulation can be based upon the increment size
20 times either the number of games or the amount wagered. In the latter case, the
accumulation can be based upon the increment size times either the number of periods
that were rate sufficient or the value metered for the period (number of games or
amount wagered). In addition, the accumulation meter can be configured to decrement
or clear if there is a lack of sufficient rate of play. To accomplish this, a delay in terms
25 of number of periods is specified. If this is set to zero, no decay/reset takes place. If
this number of periods passes without any qualified game play, the meter begins
decreasing by a specifiable reset decrement amount on each subsequent period. If the
reset decrement amount is specified as zero, the accumulation meter is simply reset.

In the case of “comp-type 2” - GAME TRIGGERED, wherein the issuance of a
30 “comp” ticket is triggered by some event during the normal play of the gaming device,
the controls for dispensing a “comp” ticket are configured to identify which game and
which award category within that game can trigger the incrementing of the
corresponding accumulation meter. The incrementing can be based on either the number

-17-

of games or upon the amount wagered. When the accumulation meter reaches the comp value, the “comp” ticket can be dispensed.

The “comp-type 3” - LOSING STREAK criteria need only be configured with the total number of qualifying games or the total amount wagered on qualifying games in
5 a row without a winner to be considered a losing streak. A single losing streak preferably adds an increment to an accumulation meter and, therefore, each single losing streak does not necessarily result in the dispensing of a “comp” ticket. After the accumulation meter has reached the comp value, the comp ticket can be dispensed.

For the “comp-type 4” - RANDOM OUTCOME criteria, the gaming
10 establishment need only specify an odds value ‘n’ that specifies that randomly, at an average of one in ‘n’ qualifying games, an accumulation meter will be incremented in accordance with a specific increment size. The increment size can be based upon the number of games or upon the amount wagered. When the accumulation meter reaches the comp value, the comp ticket can be dispensed.

15 Each “comp” type except “comp-type 0” (host triggered) has an accumulation meter for accumulating value towards a “comp”. The value in the “comp” accumulation meter is compared to the “comp” value for a given type of “comp” ticket. If the “comp” accumulation meter is greater than or equal to the “comp” value for that specific ticket, then that “comp” ticket is awardable. In this example where there are multiple “comp”
20 tickets corresponding to the different “comp” types, the gaming device can be configured to allow continued accumulation until the player selects his “comp”. Additionally, different prizes can be made available to a player based upon the amount of “comp” value accumulated. For example, one “comp” value may have one associated “comp” prize while more valuable prizes can be assigned higher “comp” values. In this
25 case, a player may be provided with the option of continuing to accumulate “comp” value in order to qualify for higher-value prizes. The higher value prizes become awardable when the accumulation meter reaches the corresponding “comp” value for any given prize. If accumulation is not enabled, the highest valued awardable “comp” is awarded.

30 This system also comprises a master meter which tracks the number of “comp” tickets awarded and the total value of those tickets. “Comp” tickets issued are also preferably logged into a cash-ticket log and into a game-play history log.

-18-

According to another embodiment of the present invention, a gaming system comprises multiple gaming devices wherein players can receive drawing tickets based upon certain game outcomes. At least one of the award categories causes the gaming machine to print a ticket which is valid in a drawing held periodically, e.g., weekly. The numbers or indicia can be selected by the gaming device in a quick-pick fashion or each gaming device can be provided with input apparatus for a player to choose his or her own numbers, for example, a touch screen or key pad. If a player is required to pick five or six numbers out of a large field of numbers, then prizes can be awarded for tickets with numbers matching three or more of the numbers drawn. The numbers may also be generated in a manner wherein they relate to the randomly determined outcome or some intermediate event of the wagering game. For example, if the game played on the gaming device comprises a spinning wheel or a Keno game, the number or numbers provided to the player may be the last number drawn on the wheel or Keno game. The drawing may also be non-numeric and can use any form of symbol. Matching all of the numbers or other symbols can provide the player with a progressive jackpot while other prizes are predetermined, fixed values. If the jackpot is not won, it preferably carries forward to the next drawing. If duplicate entry numbers are not allowed, a suitable number-generating algorithm can be used based upon the gaming device ID or upon a configured seed number provided to the gaming device, or the gaming devices can be linked such that no duplicate sets of numbers can be generated for a given drawing. If duplicate sets of numbers are permitted, then multiple winners would split the jackpot. A jackpot can be funded by the underlying game, e.g. with a percentage of the game play monies going to fund the drawing. In addition, lower-tier prizes can be cash prizes or merchandise.

The tickets issued in accordance with the present invention which are issued dependent upon a player's amount wagered, length of continuous play, etc., can measure the qualifying player activity from the start of a particular play session or at regular intervals. In the case of a play session, the play session is preferably defined as the time when money/credit is added so the gaming device no longer has a zero credit balance. The end of the play session is defined to be when the gaming device returns to a zero credit balance by the player either playing off or cashing out the credit balance and the machine staying at a zero credit balance for a certain period of time, e.g., 30

-19-

seconds. This length of time can be adjusted by the gaming establishment through an administrative screen on a host computer. The main purpose of adding the time period option is to accommodate situations where the same player has run out of money and will replenish the game and continue playing. Without this feature, the game would
5 assume the same player is a new player and would reset the accrual toward a ticket. For example, a gaming device can be set up to print a ticket when a total of \$500.00 has been wagered during a single play session. Alternatively, a gaming device can dispense tickets at regular intervals. For example, a ticket can be issued every time a predefined dollar amount has been wagered. For example, if a ticket is to be issued every time a
10 multiple of \$500.00 has been wagered over the life of the machine, then a player can receive a ticket as soon as he starts playing if a previous player or players had wagered close to, but slightly less than, the \$500.00 amount.

According to other embodiments of the present invention, tickets are dispensed from lottery terminals. The dispensed tickets are not related to the outcome on the
15 tickets purchased in a standard fashion by a lottery player. In the case of lottery terminals, players can randomly receive tickets when they purchase a lottery ticket. The ticket received may be lottery related, for example, a free scratch ticket or a free daily pick-3 entry. Alternatively, the dispensed ticket could be some other promotion or prize. The various aspects of the present invention can be used with both on-line
20 lottery tickets and two instant win tickets. Thus, the tickets of the present invention are in addition to tickets purchased by a lottery player and dispensed by a lottery terminal operator and are unrelated to the outcome on the tickets purchased by the player. Nonetheless, in addition to the random distribution of tickets to lottery ticket purchasers, other criteria can be utilized for dispensing the tickets of the present
25 invention from a lottery terminal. For example, a lottery player may be required to purchase three lottery tickets or to purchase lottery tickets of a predetermined value in order to qualify for the dispensing of these tickets. Upon qualifying, the tickets can be dispensed to qualifying lottery players either randomly or based upon some other criteria such as after a predetermined gross volume of purchases from either that particular
30 lottery terminal, a predetermined group of lottery terminals or all lottery terminals on that particular system and/or in a geographic location. Furthermore, lottery players can be provided with an identification number or magnetically encoded card which can be

-20-

swiped through or input into a lottery terminal. In this manner, a player's actual total purchases of lottery tickets within a given jurisdiction can be tracked and players can qualify for the tickets of the present invention based upon criteria such as total number of tickets purchased, total value of tickets purchased, frequency of play, frequency of
5 playing different games, etc.

FIG. 6 is an illustration of a lottery terminal which can be used in accordance with the scope of the present invention. The lottery terminal shown in FIG. 6 comprises a keyboard 610, a tiltable screen 620, ticket hopper 630, marketing display 640, bar code scanner 650, optical mark reader (OMR) 660 and magnetic strip reader 670.

10

-21-

CLAIMS

1. A gaming device comprising:
 - means for receiving a wager;
 - means for playing a wagering game wherein a player's success at said
 - 5 wagering game is, at least partially, randomly determined; and
 - means for providing a gaming award when a player is successful in said
 - wagering game and means for dispensing tickets which are not dependent on the
 - occurrence of any one particular winning outcome on said wagering game which
 - results in the player receiving a gaming award or on the player's existing credits.
 - 10
2. The gaming device according to claim 1, wherein said playing means comprises
- at least one reel display.
3. The gaming device according to claim 1, wherein said playing means comprises a
- 15 video display.
4. The gaming device according to claim 1, wherein said dispensing means is
- operable independent of said providing means.
- 20 5. The gaming device according to claim 1, wherein said providing means and said
- dispensing means comprise a ticket dispenser.
6. The gaming device according to claim 1, wherein said dispensing means is
- configured to dispense at least one ticket in response to an outcome on said wagering
- 25 game which does not result in a player receiving a gaming award.
7. The gaming device according to claim 1, wherein said dispensing means is
- configured to dispense at least one ticket in response to a series of outcomes on said
- wagering game which do not result in a player receiving a gaming award.
- 30

-22-

8. The gaming device according to claim 7, wherein said dispensing means is configured to dispense at least one ticket in response to a plurality of outcomes on said wagering game which do not result in a player receiving a gaming award within a predetermined time period.
- 5
9. The gaming device according to claim 1, wherein said dispensing means is configured to dispense a ticket after a predetermined number of plays on said gaming device.
- 10
10. The gaming device according to claim 1, wherein said dispensing means is configured to dispense a ticket randomly while said gaming device is being played.
11. The gaming device according to claim 1, wherein said dispensing means is configured to dispense a ticket randomly regardless of whether said gaming device is
- 15 being played.
12. The gaming device according to claim 1, further comprising means for receiving a player tracking card, and wherein said dispensing means is configured to only dispense tickets if a player tracking card has been inserted in said gaming device.
- 20
13. The gaming device according to claim 1 wherein said tickets comprise promotional tickets.
14. The gaming device according to claim 1 wherein said tickets comprise tickets
- 25 redeemable for at least one play on said gaming device.
15. The gaming device according to claim 1 wherein said dispensing means dispenses tickets redeemable for at least one play on another gaming device.
- 30
16. The gaming device according to claim 1 wherein said tickets comprise tickets redeemable for services provided by a gaming establishment.

-23-

17. The gaming device according to claim 1 wherein said tickets comprise scratch-off tickets.

18. The gaming device according to claim 1, further comprising a secondary gaming
5 unit comprising means for displaying a randomly selected indicia from a plurality of possible indicia.

19. The gaming device according to claim 18, wherein said secondary gaming unit comprises a wheel.

10

20. The gaming device according to claim 1, wherein said dispensing means dispenses a game ticket redeemable for play on a gaming device and a ticket providing eligibility to a drawing.

15 21. The gaming device according to claim 20 wherein said drawing ticket and said game ticket are on a single ticket.

22. The gaming device according to claim 20 wherein said drawing ticket and said game ticket are on separate tickets.

20

23. The gaming device according to claim 1 wherein said tickets comprise tickets for a drawing.

24. The gaming device according to claim 23, further comprising means for
25 automatically selecting at least one indicia from a predetermined set of indicia for said drawing.

25. The gaming device according to claim 24, wherein said selecting means is configured to select said indicia randomly.

30

26. The gaming device according to claim 24, wherein said indicia are numbers.

-24-

27. The gaming device according to claim 23, further comprising means for receiving a player's selection of at least one indicia from a predetermined set of indicia for said drawing.
- 5 28. The gaming device according to claim 27, wherein said receiving means comprises a keypad.
29. The gaming device according to claim 27, wherein said receiving means comprises a touch screen.
- 10 30. The gaming device according to claim 27, wherein said indicia are numbers.
31. The gaming device according to claim 1, wherein said dispensing means is configured to dispense tickets which are different in form from said gaming award.
- 15 32. The gaming device according to claim 1, wherein said dispensing means comprises means for printing said tickets.
33. The gaming device according to claim 32 wherein said printing means is configured to print indicia responsive to at least one of a plurality of signals generated at a location remote from said gaming device.
- 20 34. The gaming device according to claim 33, wherein said plurality of signals are generated by a gaming establishment.
- 25 35. The gaming device according to claim 34, wherein said plurality of signals are generated in direct response to operator input.
- 30 36. The gaming device according to claim 32, wherein said printing means is configured to print indicia responsive to at least one of a plurality of signals generated in response to player input at said gaming device.

-25-

37. A method of conducting a wagering game on an electronic gaming device, comprising:

5 providing a gaming device comprising means for playing a wagering game, means for accumulating comp points and means for displaying a visible indication of a player's accumulated comp points;

10 providing a player with an opportunity to place a wager;

playing a wagering game on said gaming device wherein a player's success at said wagering game is, at least partially, randomly determined; and

15 providing a player with the ability to redeem comp points by providing input at said gaming device.

38. The method of conducting a wagering game on an electronic gaming device according to claim 37, further comprising displaying at least one redemption option to a player at said gaming device.

15

39. The method of conducting a wagering game on an electronic gaming device according to claim 37, further comprising changing the display of at least one redemption option at said gaming device.

20 40. The method of conducting a wagering game on an electronic gaming device according to claim 37, further comprising requiring player input at said gaming device prior to displaying said player's accumulated comp points.

25 41. The method of conducting a wagering game on an electronic gaming device according to claim 37, further comprising requiring player input at said gaming device prior to redemption of comp points.

30 42. The method of conducting a wagering game on an electronic gaming device according to claim 37, wherein providing a player with the ability to redeem comp points comprises dispensing a ticket which is redeemable for the comp goods or services from said gaming device.

-26-

43. The method of conducting a wagering game on an electronic gaming device according to claim 42, wherein providing a player with the ability to redeem comp points also comprises printing a redeemable ticket at said gaming device.
- 5 44. The method of conducting a wagering game on an electronic gaming device according to claim 37, further comprising accumulating a plurality of comp values according to different comp criteria.
- 10 45. The method of conducting a wagering game on an electronic gaming device according to claim 37, wherein said plurality of comp values have corresponding comp awards.
- 15 46. The method of conducting a wagering game on an electronic gaming device according to claim 45, wherein each comp value has a different corresponding comp award.
- 20 47. The method of conducting a wagering game on an electronic gaming device according to claim 44, further comprising providing a player the opportunity to continue accumulating comp value according to a comp criteria even after said player has reached a comp value level which qualifies for an award.

FIG. 1

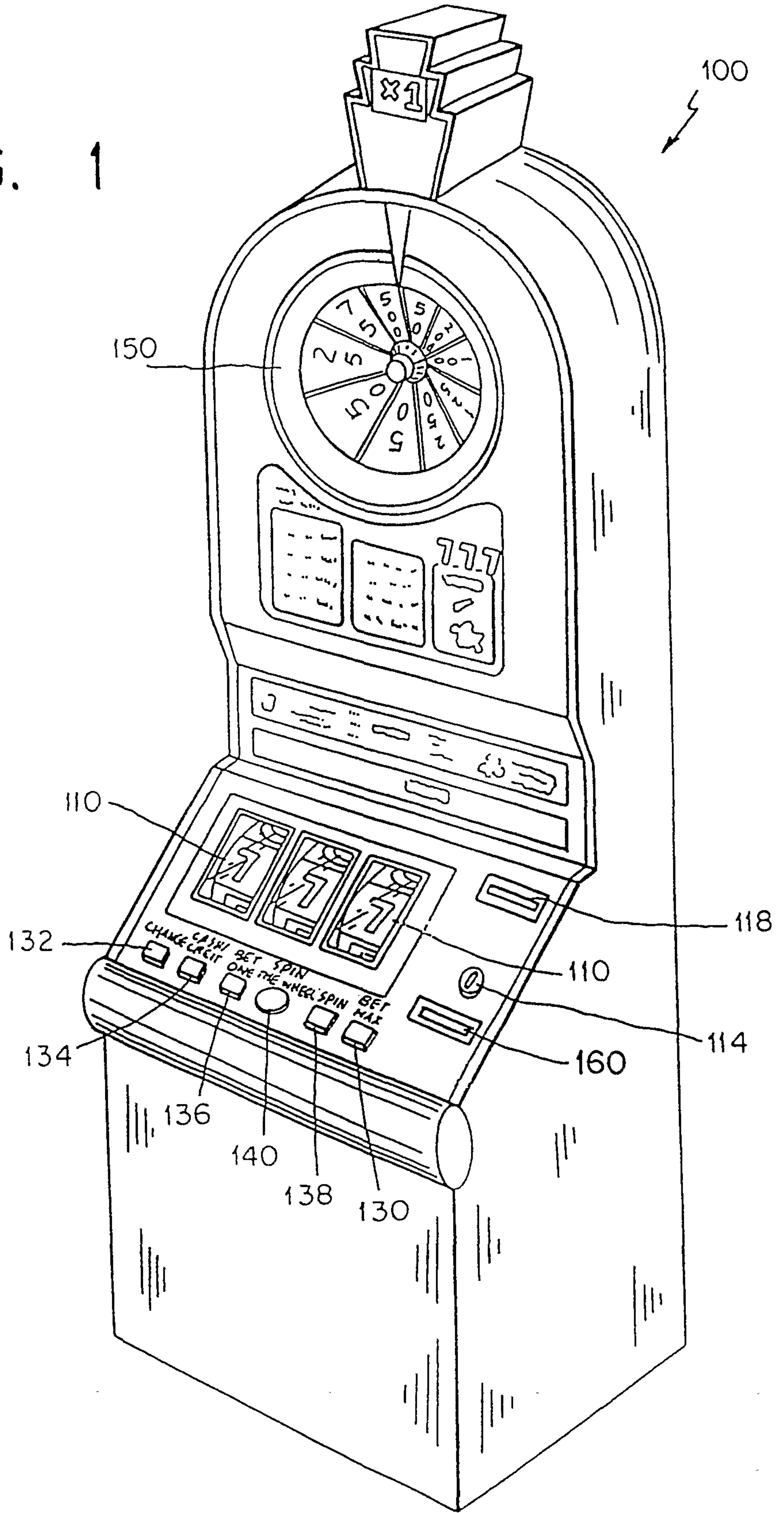
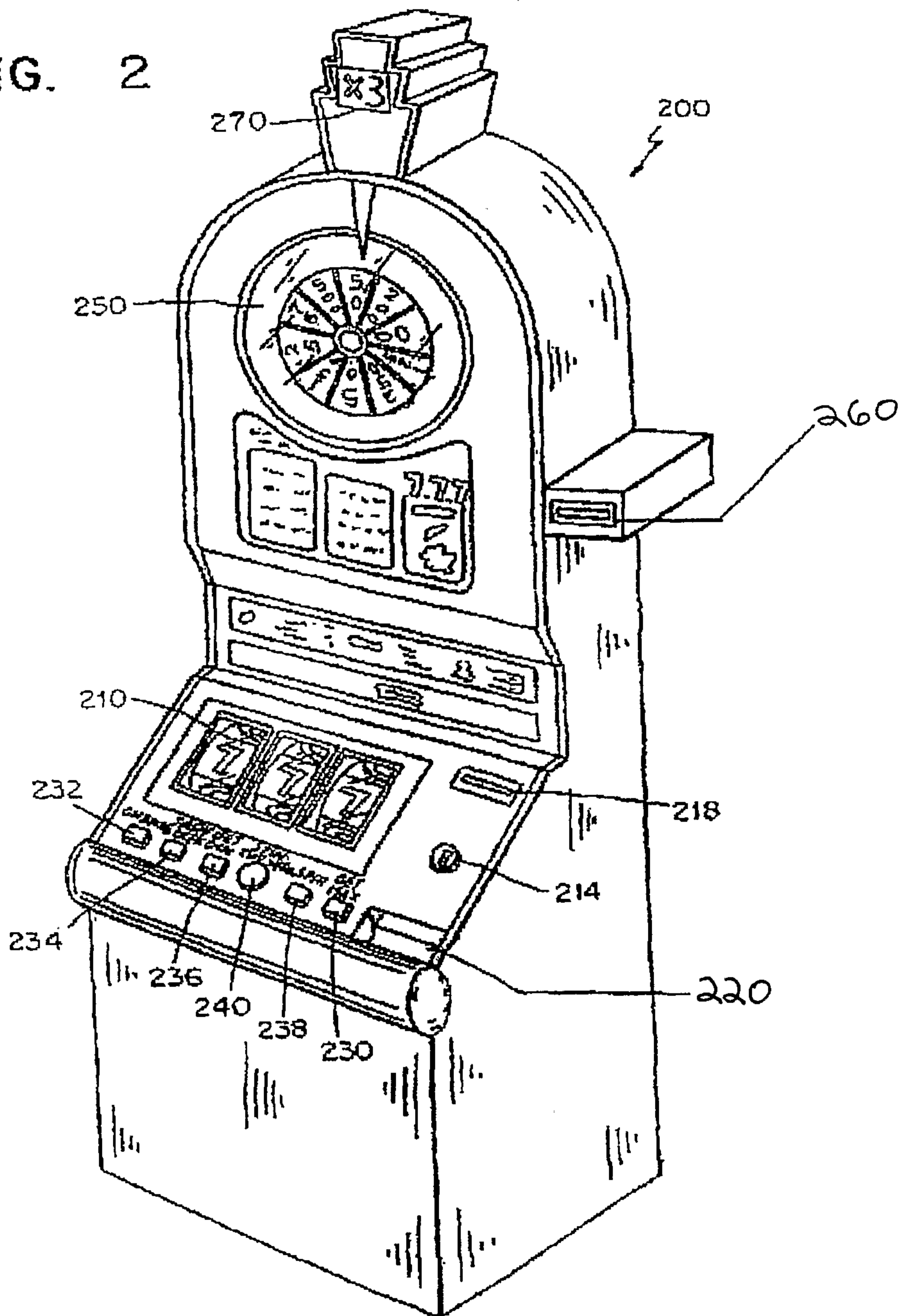

FIG. 2



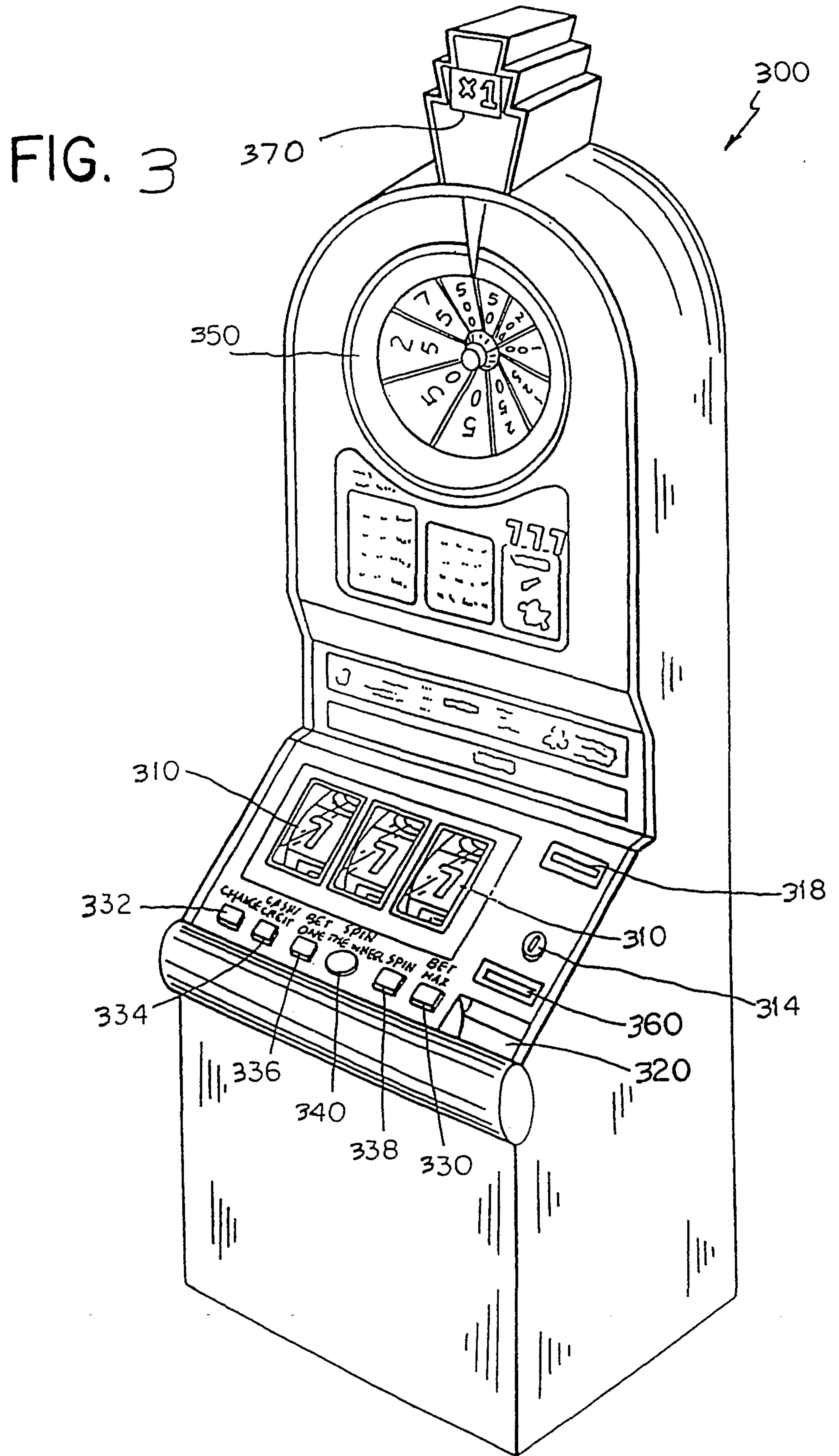

FIG. 4

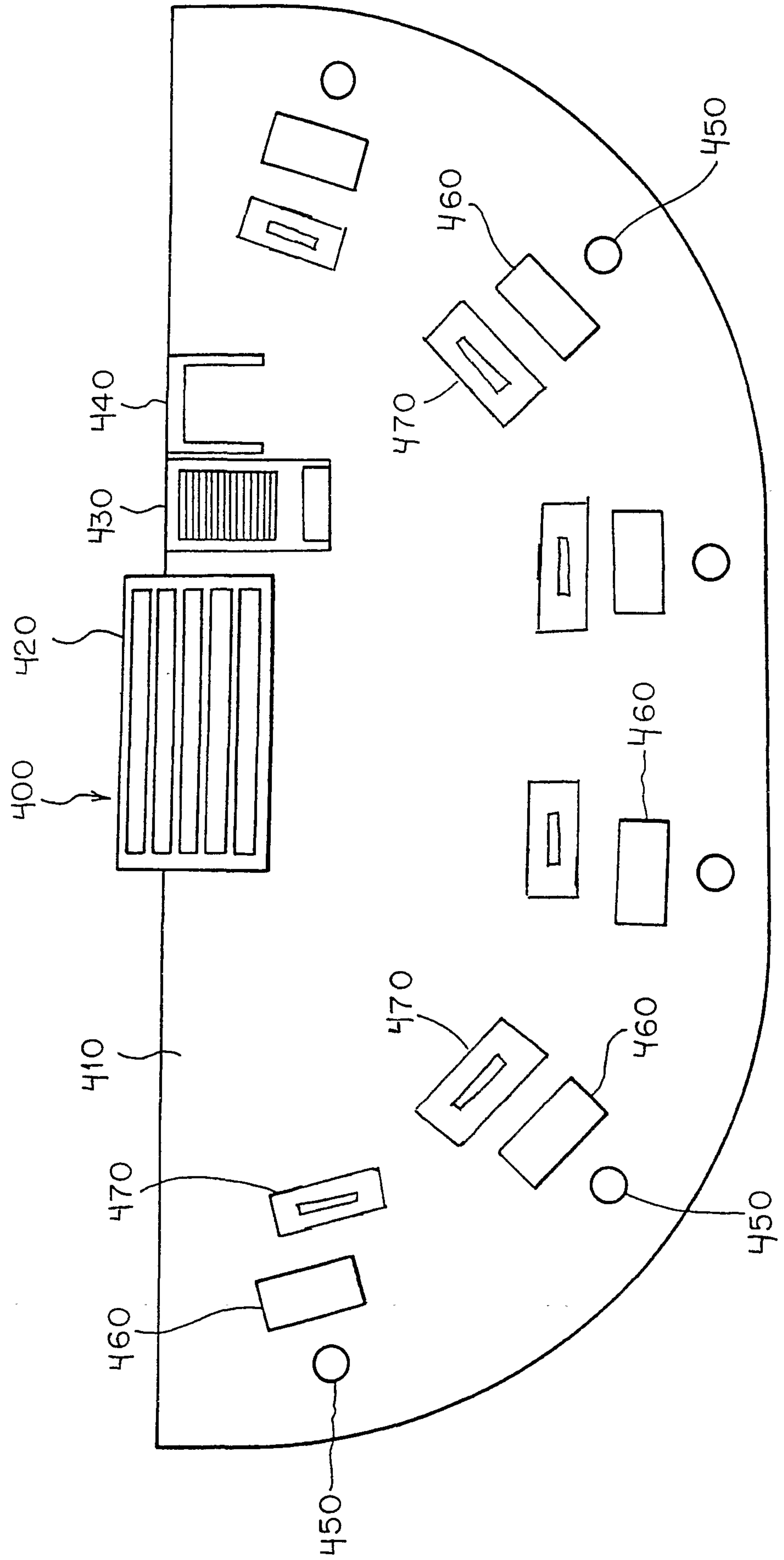

FIG. 5

