

(19) World Intellectual Property Organization
International Bureau



(43) International Publication Date
17 May 2001 (17.05.2001)

PCT

(10) International Publication Number
WO 01/34502 A1

- (51) International Patent Classification⁷: B65D 88/14, 88/74
- (21) International Application Number: PCT/SE00/02203
- (22) International Filing Date:
10 November 2000 (10.11.2000)
- (25) Filing Language: English
- (26) Publication Language: English
- (30) Priority Data:
9904127-9 12 November 1999 (12.11.1999) SE
- (71) Applicant (for all designated States except US): ENVIRO-TAINER ENGINEERING AB [SE/SE]; Lagga Marma, S-741 93 Knvista (SE).
- (72) Inventor; and
- (75) Inventor/Applicant (for US only): NORELIUS, Stefan [SE/SE]; Bruket 33, S-760 31 Edsbro (SE).
- (74) Agents: STENBORG, Anders et al.; Aros Patent AB, Box 1544, S-751 45 Uppsala (SE).
- (81) Designated States (national): AE, AG, AL, AM, AT, AT (utility model), AU, AZ, BA, BB, BG, BR, BY, BZ, CA, CH, CN, CR, CU, CZ, CZ (utility model), DE, DE (utility model), DK, DK (utility model), DM, DZ, EE, EE (utility model), ES, FI, FI (utility model), GB, GD, GE, GH, GM, HR, HU, ID, IL, IN, IS, JP, KE, KG, KP, KR, KR (utility model), KZ, LC, LK, LR, LS, LT, LU, LV, MA, MD, MG, MK, MN, MW, MX, MZ, NO, NZ, PL, PT, RO, RU, SD, SE, SG, SI, SK, SK (utility model), SL, TJ, TM, TR, TT, TZ, UA, UG, US, UZ, VN, YU, ZA, ZW.
- (84) Designated States (regional): ARIPO patent (GH, GM, KE, LS, MW, MZ, SD, SL, SZ, TZ, UG, ZW), Eurasian patent (AM, AZ, BY, KG, KZ, MD, RU, TJ, TM), European patent (AT, BE, CH, CY, DE, DK, ES, FI, FR, GB, GR, IE, IT, LU, MC, NL, PT, SE, TR), OAPI patent (BF, BJ, CF, CG, CI, CM, GA, GN, GW, ML, MR, NE, SN, TD, TG).
- Published:**
- With international search report.
 - Before the expiration of the time limit for amending the claims and to be republished in the event of receipt of amendments.
- For two-letter codes and other abbreviations, refer to the "Guidance Notes on Codes and Abbreviations" appearing at the beginning of each regular issue of the PCT Gazette.

(54) Title: CONTAINER FOR SENSITIVE CARGO

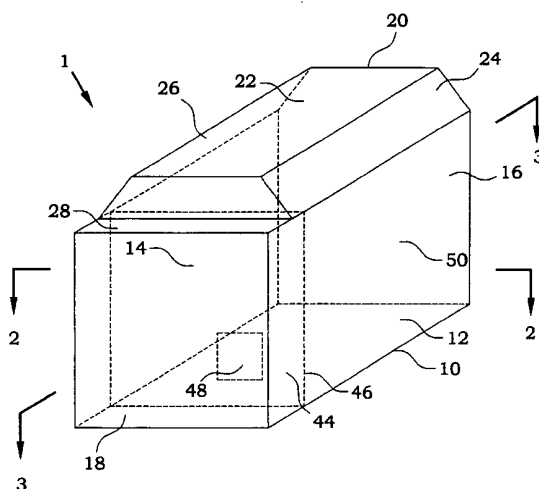

(57) Abstract: The present invention discloses a container with a height exceeding the normal container heights for air-freight. The increased ceiling height is provided in a central part (22) of the container, while portions (24, 26, 28) with reduced height is provided at least along one of the side walls (12, 14) and one of the end walls (16, 18), extending along the entire wall length. The container is made by a framework of profiles connected by thermally insulated panels. The profiles are preferably produced in two major metallic parts, interconnected by polymer connection profiles. The container is sealed for obtaining clean room conditions during transportation. A control compartment (44) is provided at one end of the container. A blow out panel (48) is provided at the wall separating the cargo compartment (50) from the control compartment (44).



WO 01/34502 A1

CONTAINER FOR SENSITIVE CARGO

TECHNICAL FIELD

5 The present invention relates in general to freight containers and in particular to air-cargo containers or other ULD:s (Unit Load Devices) equipped for transporting sensitive cargo.

BACKGROUND

10

In the prior art, ULD are provided e.g. by temperature regulating equipment. However, for cargo putting very large demands on temperature, humidity, cleanness, volume and load, there are at present no satisfactory solutions.

15

In the patent documents of US 4,046,277 and US 3,575,312, air-freight containers are disclosed, having portions of a lower height along the side walls, in order to fit to the shape of the cargo room of an air-plane. However, since the loading of such a container does not involve any turning of the container, this container has to be relatively short in order to fit through the

20

width of the entrance door to the air-plane.

SUMMARY

25

A general object of the present invention is thus to provide a container suitable for air-freight with improved possibilities to handle sensitive goods. An object of the present invention is to provide an air-freight container with improved properties concerning thermal isolation. A further object of the present invention is to provide an air-freight container designed for high point loads. Another object of the present invention is to provide an air-

30

freight container with an increased admitted cargo volume. Yet another object of the present invention is to provide an air-freight container which provides clean room conditions for the cargo compartment.

The above objects are achieved by a container according to the enclosed claims. In general words, a container with a height exceeding the normal container heights for air-cargo containers is provided. The increased ceiling height is provided in a central part of the container, sloping towards the longitudinal edges, extending along the entire longitudinal edge. At least one of the short sides presents a cut-away portion extending along the entire length of the short side, in order to facilitate loading in an air plane. The container is built from a framework of profiles connected by thermally insulated panels. The profiles are preferably produced in two major metallic parts, interconnected by polymer connection profiles, in order to break heating bridges. In a further preferred embodiment, the container is sealed for obtaining clean room conditions during transportation. A control compartment is provided at one end of the container, handling temperature and humidity control. A blow out panel is provided at the wall separating the cargo compartment from the control compartment. Furthermore, the base of the container is preferable built by an inner base of a panel, formed by two parallel sheets interconnected by vertical plates, attached to an outer base built of a framework of profiles. Attachment means, secured at the bottom side of the inner base, are provided for allowing point loads to be secured safely.

BRIEF DESCRIPTION OF THE DRAWINGS

The invention, together with further objects and advantages thereof, may best be understood by making reference to the following description taken together with the accompanying drawings, in which:

FIG. 1 is a schematic drawing of an embodiment of a container according to the present invention;

FIG. 2a-c are transversal cross-sections of a container according to the present invention;

FIG. 3a, 3b are longitudinal cross-sections of a container according to the present invention;

FIG. 4a is cross-sections of a construction profile, which can be used as a door frame of a container according to the present invention;

FIG. 4b is cross-sections of a construction profile, which can be used in a corner of a container according to the present invention;

5 FIG. 5 is a schematic drawing of a base element of a container according to an embodiment of the present invention; and

FIG. 6a, 6b are details of the drawing in fig. 5.

DETAILED DESCRIPTION

10 Unit Load Device (ULD) is a common term including different types of containers for air-freight. Thus, the use of the term ULD implies the intended use of the device for air-freight, and the requirements and problems connected therewith.

15 Fig. 1 illustrates an embodiment of the present invention. An air-freight container, generally referred to as 1, comprises a base 10, side walls 12, 14, end walls, 16, 18 and a ceiling 20. The walls 12-18 and the ceiling 20 are typically built by thermally insulating panels, connected by profiles. The
20 profiles are normally provided in each corner of the container 1, but may also be used elsewhere, where there is need for a structural enhancement.

The container of the present embodiment is primarily intended to be used as an air-freight container. Of course, the construction as such can be used as
25 a land or sea freight container as well. However, the central invention features solve problems connected with air-freight, and hence, the enclosed claims are only directed to containers for use in air-freight. For the land and sea transports, the container is provided with lifting and attachment means according to appropriate standards. The lifting means are e.g. provided at a
30 certain position, and the width and length of the container is also according to relevant standards. For air-cargo containers, there are other standards that have to be met, which normally gives a maximum height of the container. The standards puts some limitations on the shape and size of the

container. So does also the measures of the air planes. An air-cargo container is e.g. typically not higher than about 9 feet (2.8 meters), in order to fit into either of two positions in an upper deck cargo room of a Boeing 747 freighter. However, in certain cases, large cargo units are requested to be transported by air. If the height of the cargo unit exceeds the available inside measures of a container according to the air-cargo container standards, the unit has to be disassembled before transport.

According to the present invention, the useful height of an air-cargo container 1 may be increased, at least for a part of the loading area. In an air plane, the height limitations are set by the rounded-off shape of the cargo room. Since there are normally two positions in the cargo room, the limitations are really only present at one side of the container, since the ceiling of the cargo room increase towards the middle. By having a higher container ceiling height than normal, but letting the height decrease towards one of the side walls 12, 14, in order to meet the cargo room dimensions, the container 1 may still be possible to load in e.g. a Boeing 747 freighter. The portion of the ceiling 20 with reduced height 24, 26 may be present only at the side positioned against the wall of the air plane cargo room, but in order to be able to position the container 1 in any position in the cargo room, the portion of reduced height 24, 26 is preferably present at both sides of the container. However, the portion of reduced height 24, 26 always extends along the entire length of the container. The central part 22 of the container thus has ceiling height which may be considerably higher than with conventional containers.

When loading a general container in e.g. a Boeing 747 freighter, one of the end walls is entered into the cargo room through an opening. The container end will be brought until it reaches a stopping means of a transporting system within the cargo room. The container is then normally slowly turned along the air plane direction while putting it into its final position. The position of this stopping means is normally adjusted for normal height containers, which means that a container with an increased height may

collide with the ceiling in the inner part of the cargo room. This collision problem may be avoided by also providing a portion of reduced height 28 in the area close to one of the end walls, preferable the one opposite of the entrance doors of the container. The portion of reduced height 28 always extends along the entire width of the container. Preferably, this height reduction 28 towards the end door is only provided at one side. The height reduction 28 may be present at both sides, but will then either give a door height which is lower than the maximum height within the container, or give a complex design of the doors. Upon loading the container 1 according to the present invention in an air plane, the end wall 18 adjacent to a height reduction portion 28 is first entered into the cargo room, and this end wall 18 will be able to reach the stopping means without colliding with the ceiling of the air plane.

The portions with reduced height 24, 26, 28 may be designed in different ways. In the embodiment of fig. 1, the portion is divided into three parts, two side parts 24, 26, comprising sloping flat panels between the horizontal maximum height portion 22 and the side walls 12, 14, and one end part, which provides a recess 28 in the ceiling 20. Other designs are also possible. Fig. 2a-c illustrates the transversal cross section profile (taken along a line as illustrated by the line 2-2 in fig. 1) of a number of embodiments according to the present invention. In fig. 2a, one side is provided by a sloping plane 30, while the other side has the full height 22. Such a container may normally only be loaded into one particular side of the air plane. In fig. 2b, both sides are provided with recesses 32, 34, leaving a rectangular central volume 22. In fig. 2c, the sides of the ceiling are rounded off, providing a generally arc-shaped ceiling 36. In the same way, the end part 28 of the portion with reduced height may be designed with different shapes. A few embodiment are illustrated as longitudinal cross sections of a container (taken along a line as illustrated by the line 3-3 in fig. 1) in fig. 3a and 3b. In fig. 3a, both ends of the container are provided with a ceiling recess 38, 40. In fig. 3b, only one of the ends has a decreased height portion, comprising a flat sloping portion 42. As anyone skilled in the art understands, there are many possible

variations and modifications, which all follows the basic idea of a decreased ceiling height close to at least one of the side walls 12, 14 and at least one of the end walls 16, 18. One important feature is, however, that the decreased ceiling height extends along the entire width and length, respectively, of the container, in order to provide its intended collision-preventing effect.

In many cases, the goods transported by a container 1 require a certain temperature. The container may be equipped with heating and/or cooling arrangements. For large containers, the heat content of the transported goods is normally quite large, and the temperature may often be maintained within a admitted temperature interval just by providing a very good heat insulation of the container 1. The container 1 of fig. 1 is built by thermally insulated panels interconnected by profiles. The heat conductance through the panels is very low and the major heat transportation through the container walls usually takes place through the profiles, which typically are made of aluminium.

In fig. 4a, an alternative profile arrangement is presented, which provides a highly improved heat insulation. The profile arrangement comprises an outer metallic profile portion 62 and an inner metallic profile portion 60. These metallic profile portions 60, 62 are preferably of aluminium. The outer profile portion 62 and the inner profile portion 60 are interconnected by a number of distance profiles 70 made of a heat insulating material, preferably polymer material. The distance profiles 70 maintains the outer and inner profile portions 60, 62 separated in order to break any heat conducting bridges through the wall. The inner profile portion 60 comprises an inner retaining projection 76 and the outer profile portion 62 comprises an outer retaining projection 78. The insulating panels are positioned between these retaining projections and fastened thereto. The insulating panels are typically made of an outer polymer surface 66, and an inner polymer surface 68, between which an insulating material 64 is arranged.

The profiles 60, 62, 70 are serving as structural members of the container 1, providing rigidity and load bearing means. In certain cases, aluminium profiles may be too weak, in particular in the vicinity of e.g. doors. The profiles are then preferably designed forming cavities 72, closed or open, into which structural strength enhancing elements, such as steel beams may be introduced. The profile may also preferably be formed to provide the stationary part of a hinge for the container doors. The entire hinge may then easily be folded into the container wall, not requiring any space outside the surface of the wall. This reduces the risk for damages of such details. The outer profile portion may preferably also be provided with a sealing surface 73, against which the doors sealing is arranged when the door is closed. The sealing surface 73 is preferably inclined, having a thicker measure at the inner side than at the outer side. A closed container 1 in which a pressure lower than the surroundings have is present, is difficult to open unless the pressure difference is removed. The inclined surface 73 facilitates the opening of a door, since it almost immediately admits an air passage upon opening the door.

The profiles may also be used in ordinary corners without door arrangements. Such a profile arrangement is schematically illustrated in fig. 4b. Here, both metal profile portions 60, 62 have retaining projections 76, 78 in two directions, being capable of connecting two wall or ceiling panels 64-68. As anyone skilled in the art understands, the actual design of the profiles are adjusted according to the requirements, and many modifications and variations are thus possible.

Some goods to be transported may require extremely clean conditions, usually called clean room conditions. The number of particles in the air, the atmosphere composition etc. has to be carefully controlled. A container 1 for transporting of such goods thus has to be carefully sealed, in order to maintain the clean conditions inside. No exchange of air between the inside and the outside of the container 1 is admitted. This puts a number of constraints on the container construction. When transporting a container 1

in an air plane, the container 1 must be possible to open extremely fast, if a sudden drop of pressure occurs during the flight, in order to prevent the container from exploding. Regulations state that the container has to be possible to evacuate within 0.2 seconds. In containers having an admitted
5 air flow in and out from the container a double directed valve may be provided for this purpose. In containers 1 having clean room conditions inside, such a solution is out of the question.

The container 1 in fig. 1 is intended to be used for clean room conditions. At
10 one end of the container 1, a separate control compartment 44 is provided. In the control compartment 44, equipment for regulating the temperature and humidity of the cargo compartment 50 of the container 1 is placed (not shown in the figure for the sake of clarity). The climate equipment may e.g. comprise a heater, a cooler and a humidity controlling device. Moreover,
15 these components may be driven either by an electric motor or a diesel motor, depending on the available electrical connections. During flight, the motors have to be turned off due to safety regulations. The control compartment 44 is separated from the cargo compartment 50 by a separating wall 46. A blow out panel 48 is arranged at the separating wall
20 46. At an emergency situation, the pressure drop will rapidly evacuate the control compartment 44, which is connected with the outside by large ventilation openings. The pressure difference between the cargo compartment 50 and the control compartment 44 will be the same as the pressure different over any other of the walls of the cargo compartment 50.
25 The blow out panel 48 is arranged to be released at a certain pressure difference, and the air of the container evacuates easily through the control compartment 44.

When the blow out panel 48 releases, the pressure at the blow out panel 48
30 is so high that the blow out panel 48 will be thrown with a large force out from the separating wall 46. The outer wall 18 of the control compartment 44 will prevent the blow out panel 48 from leaving the container 1, thus also preventing it from damaging the air plane itself or any persons within the

cargo room of the air plane. By letting the blow out panel 48 be released into the control compartment 44, the external damage caused by such an action will be reduced.

5 When transporting heavy goods, certain additional precautions have to be made. If the load is distributed over the entire floor area, the base will experience a distributed load, which normally is easy to handle. However, if the load is present as point loads, at certain positions within the container 1, the situation is more severe. Furthermore, if the goods has to be secured
10 directly to the floor, the requirement for avoiding e.g. base distortions are large.

In fig. 5, a schematically drawing of an embodiment of a base of a container is illustrated in a partially separated view. The base 10 comprises a lower, outer base portion 80 and an upper, inner base portion 86. The outer base portion 80 is structurally rigid and preferably formed as a framework of beams 82. The interspaces 84 within the outer base portion 80 are preferably filled with thermally insulating material. The inner base portion 86 is secured to the outer base portion 80 e.g. by means of screwing it to the
15 beams 82 of the outer base portion 80. The inner base portion 86 is as shown in fig. 6a and 6b (which are detail drawings of the encircled part in fig. 5), preferably composed by substantially vertically positioned plates 96, preferably, aluminium plates, connected at the upper and lower edges thereof to an upper 92 and lower 94 cover sheet, respectively. The plates 96
20 may also be made of a thermally insulating material. The cover sheets 92, 94 are preferably made of a polymer material. The vertical plates 96 are preferably formed and positioned in closed geometrical patterns, with the plates 96 directed in at least two distinctive directions. A simple and preferred arrangement is a honeycomb pattern, as illustrated by fig. 6b.
25 Such an arrangement creates an inner base portion 86, which has a high rigidity for local strains. A closer arrangement of vertical plates 96 gives a higher load carrying capacity and a stiffer inner base portion 86. Since the inner base portion 86 furthermore is firmly fixed to the rigid outer base
30

portion 80, the assembly achieves a property of distributing point loads in an efficient way.

Attachment means 90 are provided at the inner base portion 86. The attachment means 90 are reachable from above, i.e. from the inside of the container 1, available for firmly fixing the load to the container floor. The attachment means 90 are firmly secured against the lower cover sheet 94 of the inner base portion 86, preferably from below, in order to use the rigidity and bending properties of the inner base portion 86. In the embodiment illustrated in fig. 6b, the attachment means comprises a base plate 98, screwed or riveted 102 to the bottom side of the lower cover sheet 94. From the base plate 98, a tube member 100 with inner threads extends through the inner base portion 86. The threaded tube 100 hence offering a secure attachment point for heavy point loads. With a cover sheet 92, 94 thickness of 0.1 inch (2.5 mm) and a honeycomb structure of aluminium plates with an honeycomb cell size of 1 inch (25 mm), the attachment means 90 will withstand a vertical load of 60 kN and a horizontal load of 150 kN. According to an ISO standard for air cargo containers, the floor should carry 2 tons per point and withstand collision forces of 2 G. The present construction will carry 15 tons per point and withstand 6 G.

It will be understood by those skilled in the art that various modifications and changes may be made to the present invention without departure from the scope thereof, which is defined by the appended claims. In the detailed description, an air-cargo container is described. However, also other unit load devices may be constructed from the same principles.

CLAIMS

1. A unit load device suitable for air-freight, comprising a base (10), side walls (12, 14), end walls (16, 18) and a ceiling (20), **characterised in that** said ceiling (20), along one at least of the side walls (12, 14) and along at least one of the end walls (16, 18), is provided with portion with a reduced height (24, 26, 28, 30, 32, 34, 36, 38, 40, 42), said portion with a reduced height (24, 26, 28, 30, 32, 34, 36, 38, 40, 42) extending along the entire length of respective wall (12, 14, 16, 18).

2. The unit load device according to claim 1, **characterised in that** said portion comprises a substantially flat, sloping plane (24, 26, 30, 42).

3. The unit load device according to claim 1, **characterised in that** said portion comprises a recess (28, 32, 34, 38, 40) in said ceiling (20).

4. The unit load device according to any of the claims 1 to 3, **characterised in that** said container end walls (16, 18), side walls (12, 14) and ceiling (20) are built by thermally insulating panels, interconnected by profiles, whereby at least one of said profiles has an inner portion (60) and an outer portion (62), interconnected by connection profiles (70) of polymer material.

5. The unit load device according to claim 4, **characterised in that** at least one of said profile portions (60, 62) provides a cavity (72) for a steel beam, enhancing the rigidity of said profile.

6. The unit load device according to claim 4 or 5, **characterised in that** at least one of said profiles provides a sealing surface (73).

7. The unit load device according to any of the claims 1 to 6, **characterised by**

a control compartment (94) for container climate control equipment, separated from the cargo compartment (50) of said container by a separating wall (46); and

a blow out panel (48) positioned at said separating wall (46).

5

8. The unit load device according to any of the claims 1 to 7, **characterised in that** said base (10) comprises a structurally rigid outer base portion (80) and an inner base portion (86), said inner base portion (86) comprising vertically positioned plates (96), connected at the upper and lower parts thereof to an upper (92) and lower (94) polymer sheet, respectively.

10

9. The unit load device according to claim 8, **characterised in that** said inner base portion (86) is provided with attachment means (90), available from above and secured at the lower polymer sheet (94).

15

10. The unit load device according to claim 9, **characterised in that** said attachment means (90) comprises a base plate (98), fastened at the lower side of said lower polymer sheet (94), and an tube member (100), having inner threads, said tube member (100) extending from said base plate (98) through said inner base portion (86).

20

1/4

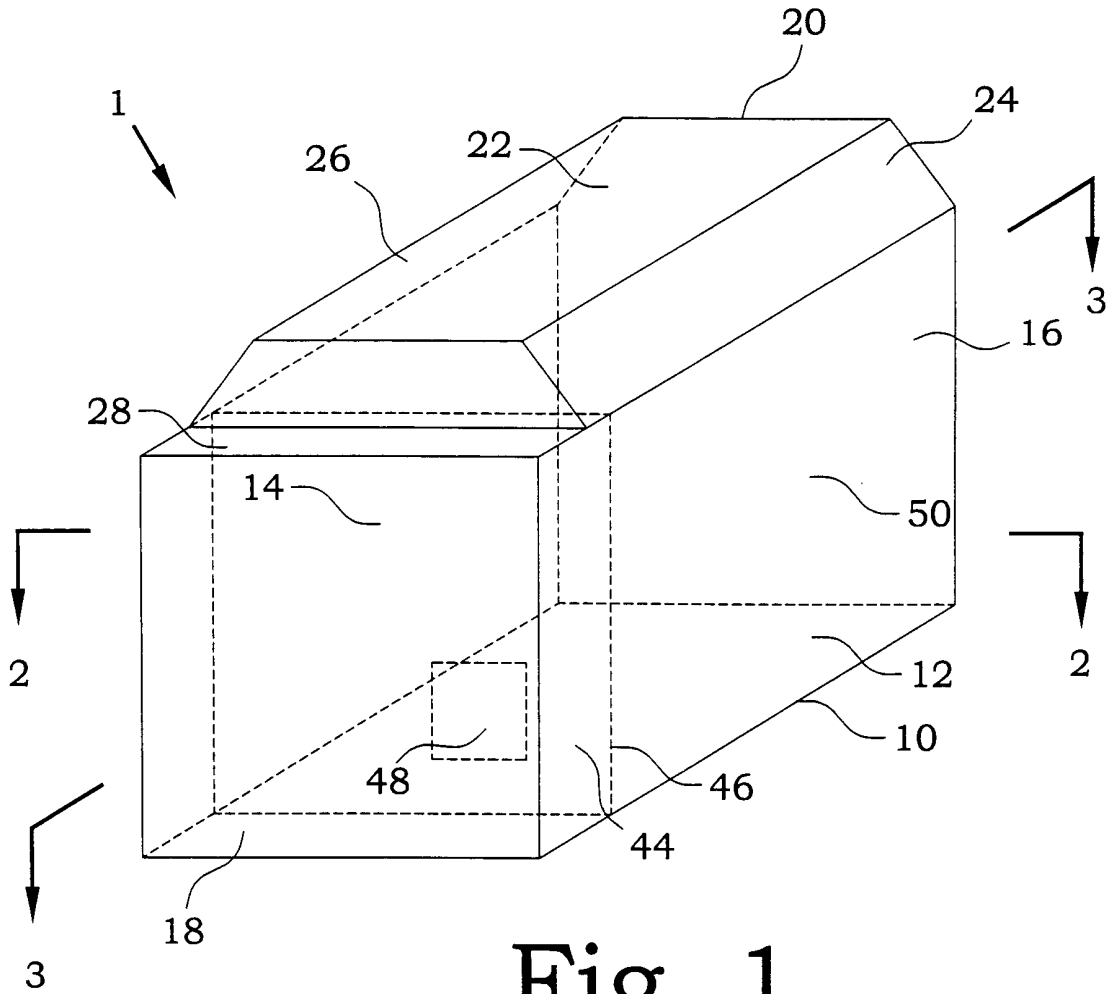

Fig. 1

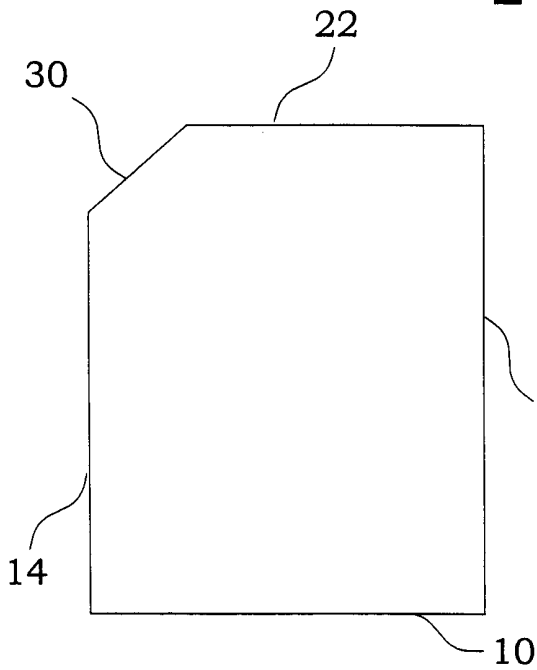

Fig. 2a

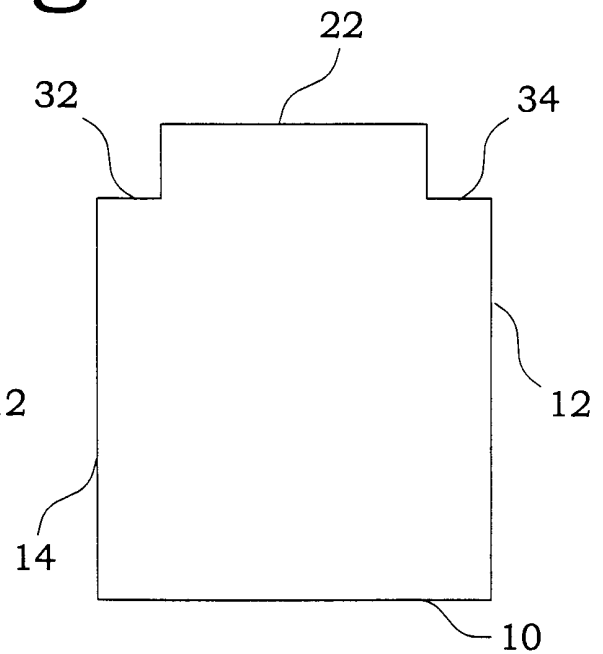

Fig. 2b

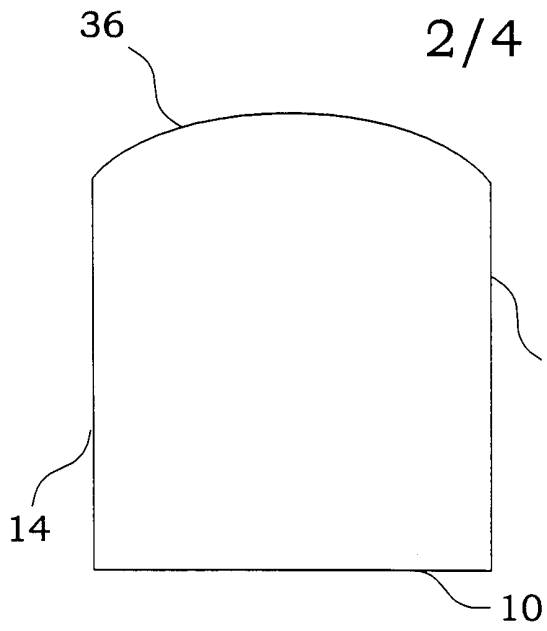

Fig. 2c

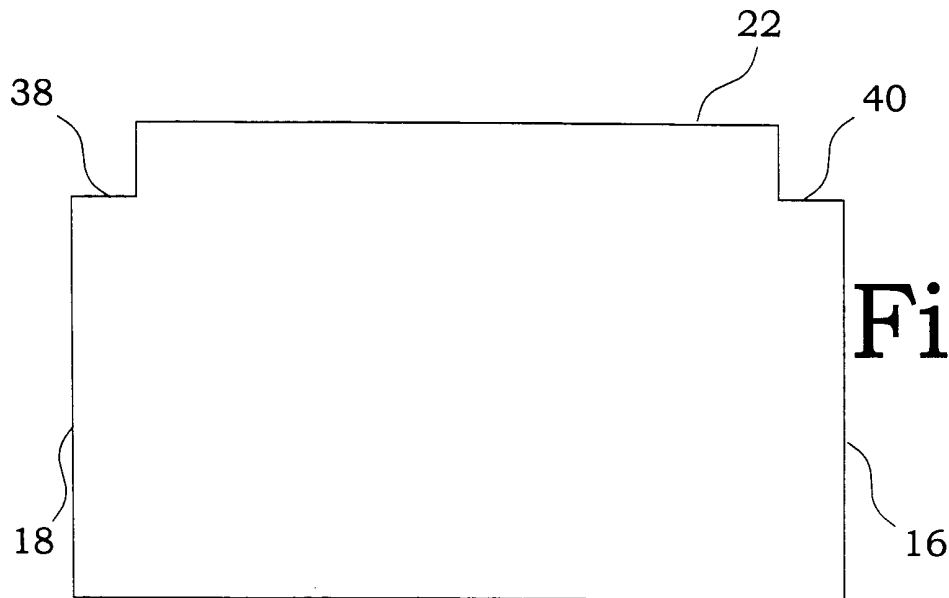

Fig. 3a

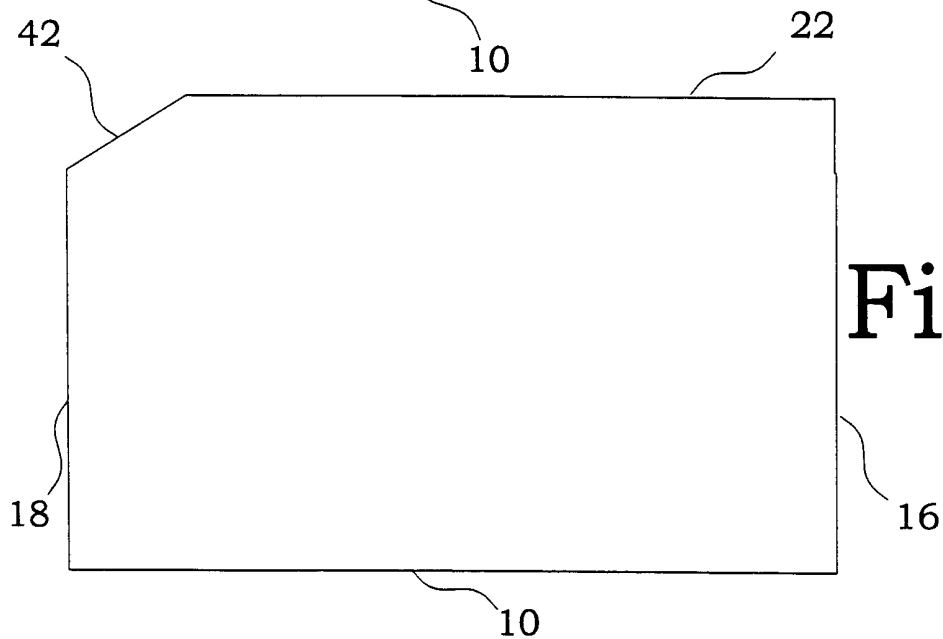
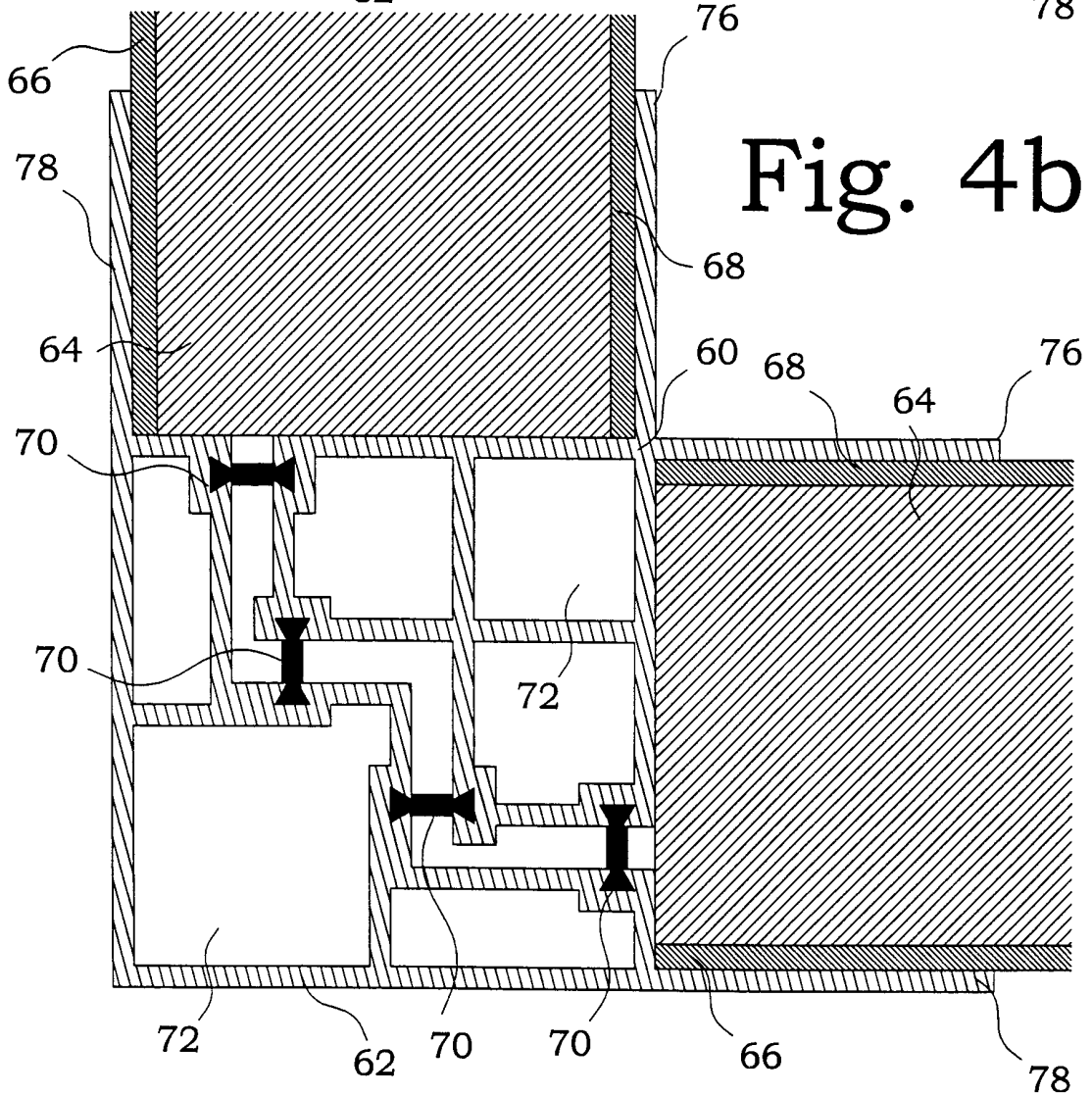
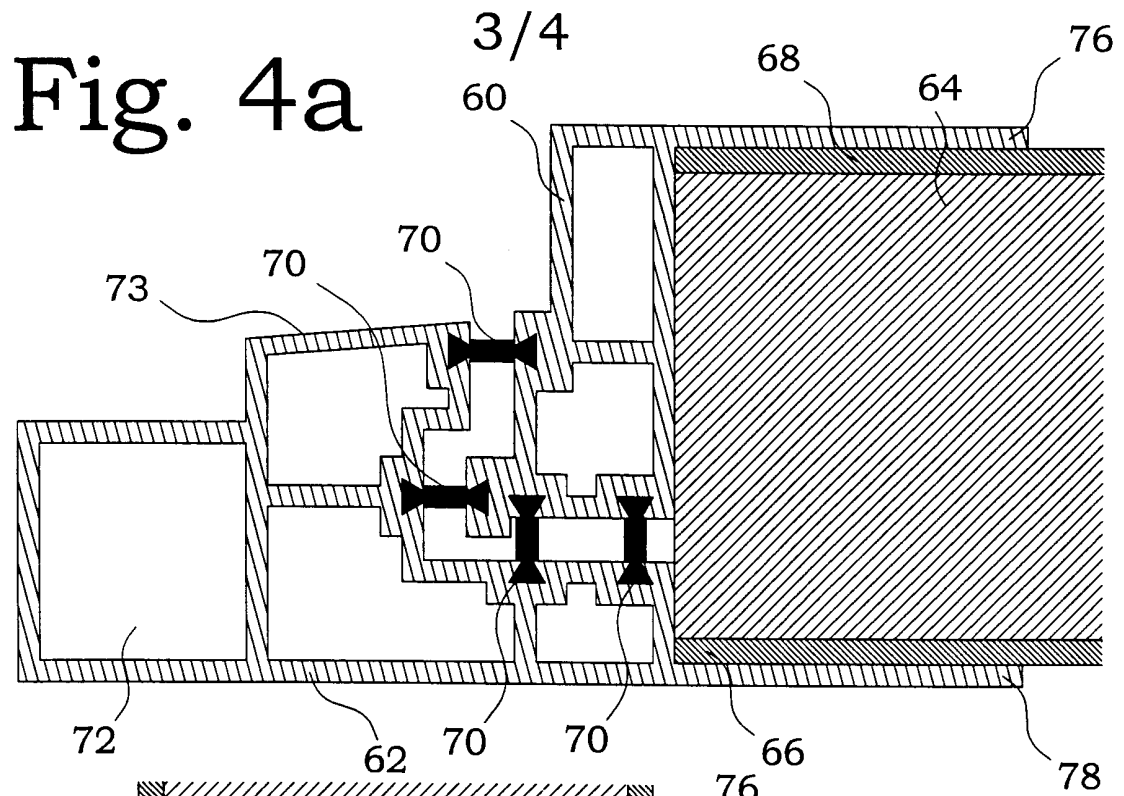

Fig. 3b



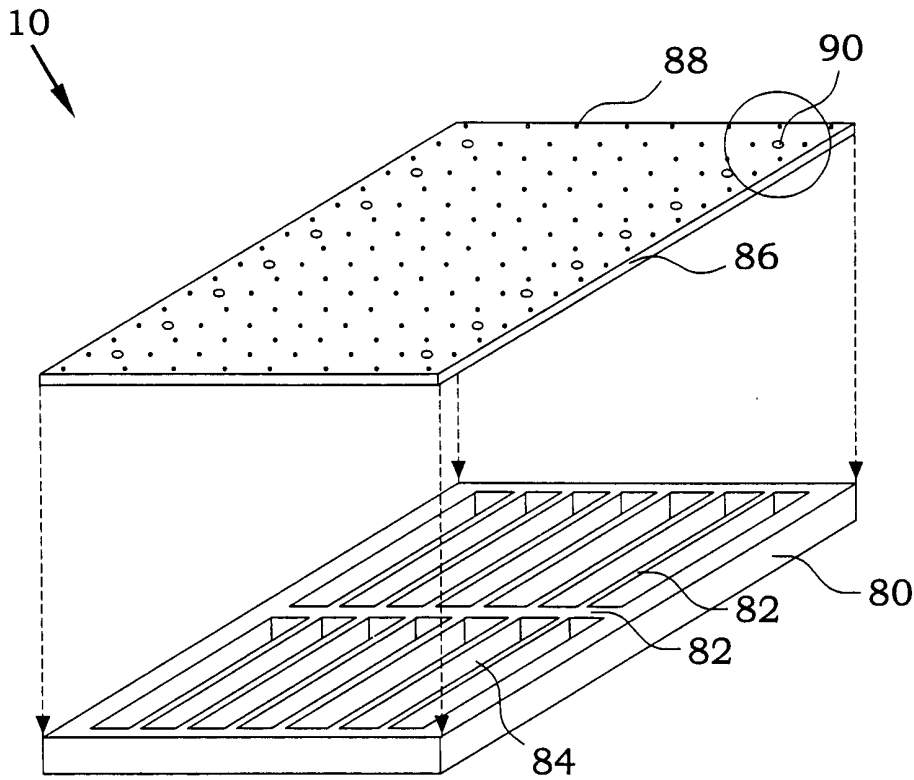

Fig. 5

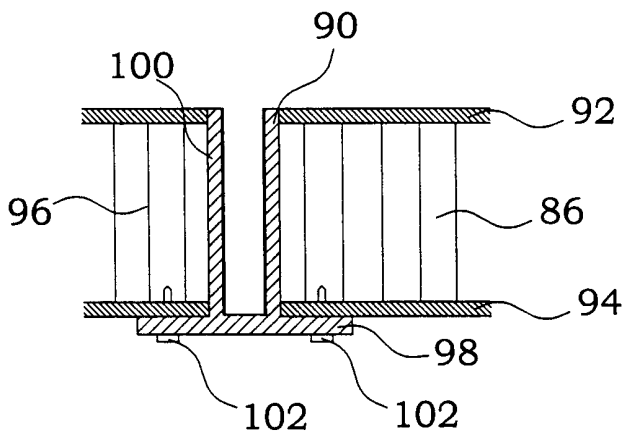

Fig. 6a

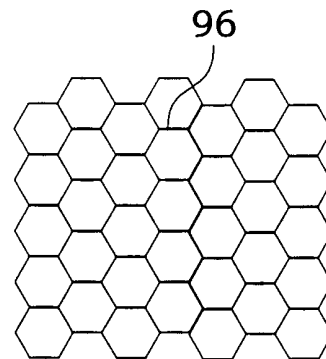

Fig. 6b

INTERNATIONAL SEARCH REPORT

International application No.

PCT/SE 00/02203

A. CLASSIFICATION OF SUBJECT MATTER		
IPC7: B65D 88/14, B65D 88/74 According to International Patent Classification (IPC) or to both national classification and IPC		
B. FIELDS SEARCHED		
Minimum documentation searched (classification system followed by classification symbols)		
IPC7: B65D		
Documentation searched other than minimum documentation to the extent that such documents are included in the fields searched		
SE,DK,FI,NO classes as above		
Electronic data base consulted during the international search (name of data base and, where practicable, search terms used)		
C. DOCUMENTS CONSIDERED TO BE RELEVANT		
Category*	Citation of document, with indication, where appropriate, of the relevant passages	Relevant to claim No.
A	WO 9107337 A1 (ROYAL ORDNANCE PLC), 30 May 1991 (30.05.91), figure 1, abstract --	7
A	WO 9215506 A1 (EUROTAINER AB), 17 Sept 1992 (17.09.92), figure 2 --	4
A	WO 9215507 A1 (EUROTAINER AB), 17 Sept 1992 (17.09.92), figure 2 --	4
A	WO 9322223 A1 (ROYAL ORDNANCE PLC), 11 November 1993 (11.11.93), figures 1,11, abstract --	4,7
<input checked="" type="checkbox"/> Further documents are listed in the continuation of Box C. <input checked="" type="checkbox"/> See patent family annex.		
<p>* Special categories of cited documents:</p> <p>"A" document defining the general state of the art which is not considered to be of particular relevance</p> <p>"E" earlier application or patent but published on or after the international filing date</p> <p>"L" document which may throw doubts on priority claim(s) or which is cited to establish the publication date of another citation or other special reason (as specified)</p> <p>"O" document referring to an oral disclosure, use, exhibition or other means</p> <p>"P" document published prior to the international filing date but later than the priority date claimed</p> <p>"T" later document published after the international filing date or priority date and not in conflict with the application but cited to understand the principle or theory underlying the invention</p> <p>"X" document of particular relevance: the claimed invention cannot be considered novel or cannot be considered to involve an inventive step when the document is taken alone</p> <p>"Y" document of particular relevance: the claimed invention cannot be considered to involve an inventive step when the document is combined with one or more other such documents, such combination being obvious to a person skilled in the art</p> <p>"&" document member of the same patent family</p>		
Date of the actual completion of the international search		Date of mailing of the international search report
2 March 2001		05-03-2001
Name and mailing address of the ISA/ Swedish Patent Office Box 5055, S-102 42 STOCKHOLM Facsimile No. +46 8 666 02 86		Authorized officer Anders Brinkman/MP Telephone No. +46 8 782 25 00

INTERNATIONAL SEARCH REPORT

International application No.

PCT/SE 00/02203

C (Continuation). DOCUMENTS CONSIDERED TO BE RELEVANT

Category*	Citation of document, with indication, where appropriate, of the relevant passages	Relevant to claim No.
A	WO 9712195 A1 (ALLIEDSIGNAL INC.), 3 April 1997 (03.04.97), page 15, line 16 - page 16, line 5, figures 10A-10D, abstract --	1,7
A	DE 1601899 A1 (LINDE AG), 6 May 1970 (06.05.70), figures 1,4, claim 1 --	1,7
A	DE 1816800 A1 (PRESSOTURN LTD.), 31 July 1969 (31.07.69), figure 5 --	1
A	DE 3151998 A1 (OSKAR DITTRICH GMBH & CO KG), 7 July 1983 (07.07.83), figures 1-3 --	1
A	DE 3709247 A1 (LONZA AG), 6 October 1988 (06.10.88), figure 1, abstract --	7
A	US 5183176 A (JOSEF MEIER ET AL), 2 February 1993 (02.02.93), figures 1,2, abstract --	1,4
A	US 5564599 A (GEORGE L. BARBER ET AL), 15 October 1996 (15.10.96), figure 1 -- -----	1,3

INTERNATIONAL SEARCH REPORT
Information on patent family members

05/02/01

International application No.
PCT/SE 00/02203

Patent document cited in search report	Publication date	Patent family member(s)	Publication date
WO 9107337 A1	30/05/91	AU 640426 B	26/08/93
		AU 6644890 A	13/06/91
		BR 9007005 A	28/01/92
		CA 2042030 A	09/05/91
		DE 69011848 D,T	27/04/95
		EP 0456779 A,B	21/11/91
		SE 0456779 T3	
		FI 97717 B,C	31/10/96
		FI 913227 D	00/00/00
		GB 8925193 D	00/00/00
		JP 2934311 B	16/08/99
		JP 4502744 T	21/05/92
		US 5360129 A	01/11/94
WO 9215506 A1	17/09/92	AU 1334092 A	06/10/92
		DE 69117067 D,T	02/10/96
		EP 0553229 A,B	04/08/93
		JP 6501555 T	17/02/94
		SE 467106 B,C	25/05/92
		SE 9100649 A	25/05/92
		US 5716854 A	10/02/98
WO 9215507 A1	17/09/92	AU 1342492 A	06/10/92
		DE 69119778 D,T	07/11/96
		EP 0550602 A,B	14/07/93
		SE 467107 B,C	25/05/92
		SE 9100650 A	25/05/92
WO 9322223 A1	11/11/93	AT 129980 T	15/11/95
		AU 672004 B	19/09/96
		AU 4267693 A	29/11/93
		CA 2134668 A	11/11/93
		DE 69300769 D,T	18/07/96
		DK 639150 T	29/01/96
		EP 0639150 A,B	22/02/95
		SE 0639150 T3	
		ES 2079979 T	16/01/96
		GB 9209242 D	00/00/00
		JP 7506074 T	06/07/95
		US 6112931 A	05/09/00
		ZA 9302975 A	21/04/94
WO 9712195 A1	03/04/97	CA 2232030 A	03/04/97
		EP 0852695 A	15/07/98
		IL 123604 D	00/00/00
		JP 11512687 T	02/11/99
DE 1601899 A1	06/05/70	NONE	
DE 1816800 A1	31/07/69	CH 483348 A	31/12/69
		FR 1604420 A	08/11/71
		GB 1248035 A	29/09/71
		NL 6900052 A	07/07/69
		US 3602400 A	31/08/71
DE 3151998 A1	07/07/83	NONE	

INTERNATIONAL SEARCH REPORT

Information on patent family members

05/02/01

International application No.

PCT/SE 00/02203

Patent document cited in search report			Publication date	Patent family member(s)	Publication date
DE	3709247	A1	06/10/88	NONE	
US	5183176	A	02/02/93	AT 111418 T	15/09/94
				CA 2029690 A	15/05/91
				DE 8913412 U	11/01/90
				DE 59007134 D	00/00/00
				EP 0428018 A,B	22/05/91
				NO 176014 B,C	10/10/94
				NO 901507 D	00/00/00
US	5564599	A	15/10/96	AU 5313396 A	02/10/96
				CA 2215419 A	19/09/96
				EP 0812286 A	17/12/97
				JP 2934509 B	16/08/99
				JP 10506600 T	30/06/98
				WO 9628360 A	19/09/96